

## MM/1 8 Megabyte DRAM Upgrade

Rev. October 11th, 1994

Thank you for purchasing the MM/1(tm) 8 Megabyte DRAM Upgrade. This upgrade is a replacement for the existing MM/1 MiniBus backplane that joins your MM/1 CPU board and the I/O board. It incorporates two SIMM memory sockets and appropriate supporting circuitry. These sockets can be populated with either 1 Megabyte or 4 Megabyte page mode SIMM memories. This RAM can now replace *or augment*, existing RAM on I/O boards of revision 1 or 2 if a hardware modification is done by qualified technicians. This means only those I/O boards produced *before BlackHawk Enterprises, Inc. began producing the MM/1*. Users of revision 3 I/O boards will have only the memory on the backplane. This backplane can be used with a floppy only MM/1 system to improve system performance, as installing the additional memory eliminates wait states.

### Installation.

First, turn off the power to your MM/1 and open the case. If you have an I/O board and it is the uppermost board in the MM/1 board set assembly, remove it. If you have an I/O board, refer to **figure 2** and remove U1, which is a 22V10 PAL. This PAL will not be reinstalled and should be put in a safe place, against a need to restore the I/O board to its original condition. You will need to remove the 1 MByte SIMMS if installed on the I/O board. If you are not yet ready to install additional memory, you will want to run this memory from the new backplane. If you are adding 4 MByte SIMMS now, install them into the SIMM sockets on the new backplane. Next, you should install the jumpers on the MM/1 CPU board, referring to **figure 1**. If you are using 1 MByte Simms install P7 B. If you are using 4 MByte SIMMS remove P7 B. P7A is used to enable or disable the DRAM on the Input-Output and/or backplane boards. If you purchase a memory test program you might need to remove P7A in order to run this test. P11 is a set of jump points located on the new backplane. It is used to set the memory refresh rates. Position 1 is the fastest rate, and position 3 is the slowest. Each time you move the jumper from a lower position to a higher one, you slow the refresh rate by a power of two. It is recommended that you use SIMMS with a speed rating of 80ns in your MM/1.

Next, create a new boot module with the correct init module for your chosen configuration. If you have been running a 1 Megabyte MM/1 and are adding two 1 Megabyte SIMMS, then change to *init\_2Meg*. If you are adding two 4 MByte SIMMS, then use *init\_8meg*. If you have a revision 1 or 2 I/O board with the correct hardware modification and are populating both sets of SIMM sockets, you should choose *init\_4meg* or *init\_10meg* as is appropriate for the combination of modules you have installed. Note that the references to memory in the above module names refer only to the amount of memory installed on the backplane and/or I/O board. Once additional memory is installed the CPU board memory is dedicated primarily to video use, and is not considered in discussion of system RAM. For more information on this subject, please refer to the **MM/1 Technical Manual**, available from BlackHawk Enterprises, Inc. For instructions

on creating a new boot file, refer to your **MM/1 Users Guide** which came with your MM/1 or the **Microware OS-9 Users Manual**, available from BlackHawk Enterprises, Inc. Reboot the system with the new boot disks, and you are now running an expanded MM/1 system with 2 or 8 megabytes of user memory. You should run *MFREE* to verify that your computer sees all of the memory.

***In Case of difficulty.***

If any problems occur there are a few things you can check.

1. Make sure your SIMMS are placed correctly and firmly into the sockets. Some SIMM brands install easily; others require a little effort. Do not force the SIMM if you are unsure it is oriented properly.
2. If you have an I/O board, did you remove the old PAL?
3. Are the jumpers installed correctly on the CPU board? Refer to **figure 1**.
4. Are your new memories good?
5. Did you use the proper **INIT module**?
6. Did you place the 4 Megabyte SIMMS on the backplane and not the I/O board?

OS-9 is a trademark of Microware Systems Corp.

MM/1 is a trademark of BlackHawk Enterprises, Inc.

This document is copyright (c) 1994 by BlackHawk Enterprises, Inc.

BlackHawk Enterprises, Inc's liability for use of these instructions shall be limited to repair or replacement of damaged MM/1 specific equipment. Deviation from the above instructions shall be undertaken at the buyers own risk.

MM/1 PROCESSOR BOARD

Remove P7 B for 4 meg simms  
 Install for 1 meg simms  
 After running ram test  
 install P7 A to enable ram

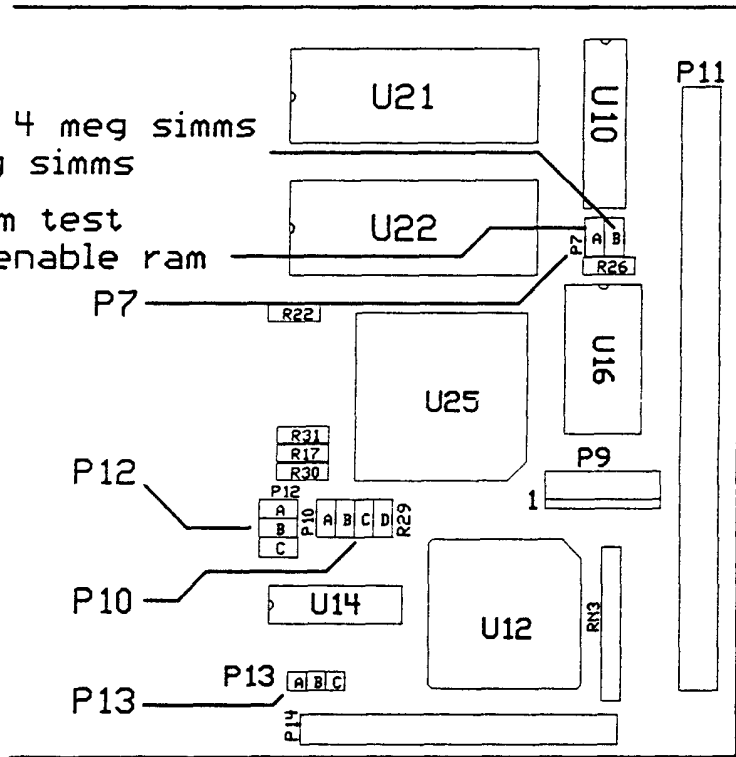

FIGURE 1

I/O BOARD

Remove 2 1MEG SIMS if installed

Remove PAL U1 and set aside

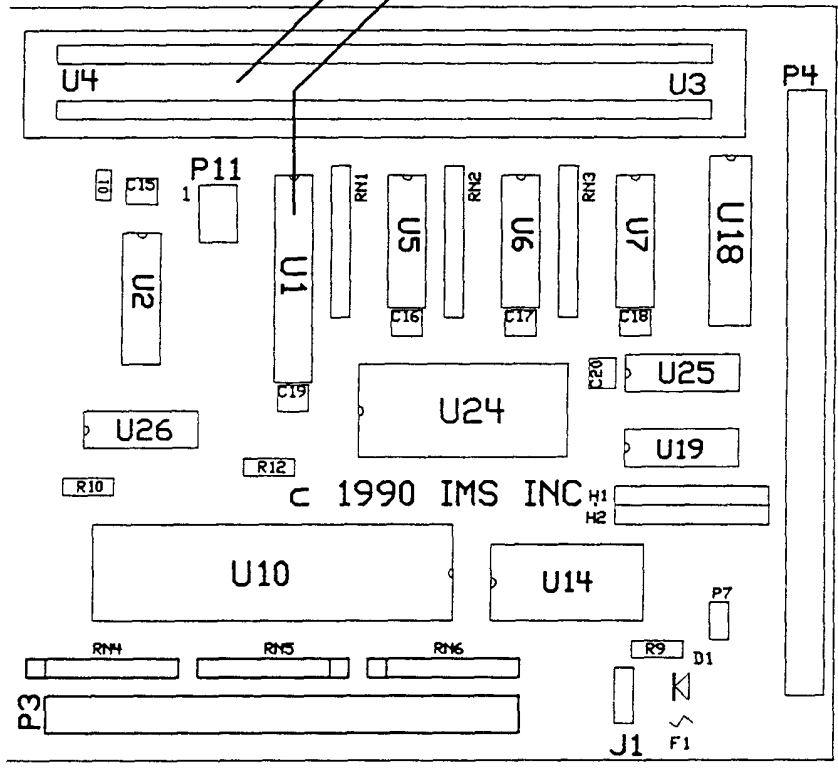

FIGURE 2

