

TRS-80[®]

DWP-210

Operation Manual Catalog Number 26-1257



Radio Shack[®]

TRS-80

**COMPUTER
PRODUCTS**

CUSTOM MANUFACTURED FOR RADIO SHACK, A DIVISION OF TANDY CORPORATION

SERVICE POLICY

Radio Shack's nationwide network of service facilities provides quick, convenient, and reliable repair services for all of its computer products, in most instances. Warranty service will be performed in accordance with Radio Shack's Limited Warranty. Non-warranty service will be provided at reasonable parts and labor costs.

Because of the sensitivity of computer equipment, and the problems which can result from improper servicing, the following limitations also apply to the services offered by Radio Shack:

1. If any of the warranty seals on any Radio Shack computer products are broken, Radio Shack reserves the right to refuse to service the equipment or to void any remaining warranty on the equipment.
2. If any Radio Shack computer equipment has been modified so that it is not within manufacturer's specifications, including, but not limited to, the installation of any non-Radio Shack parts, components, or replacement boards, then Radio Shack reserves the right to refuse to service the equipment, void any remaining warranty, remove and replace any non-Radio Shack part found in the equipment, and perform whatever modifications are necessary to return the equipment to original factory manufacturer's specifications.
3. The cost for the labor and parts required to return the Radio Shack computer equipment to original manufacturer's specifications will be charged to the customer in addition to the normal repair charge.

TERMS AND CONDITIONS OF SALE AND LICENSE OF RADIO SHACK COMPUTER EQUIPMENT AND SOFTWARE
PURCHASED FROM A RADIO SHACK COMPANY-OWNED COMPUTER CENTER, RETAIL STORE OR FROM A
RADIO SHACK FRANCHISEE OR DEALER AT ITS AUTHORIZED LOCATION

LIMITED WARRANTY

I. CUSTOMER OBLIGATIONS

- A. CUSTOMER assumes full responsibility that this Radio Shack computer hardware purchased (the "Equipment"), and any copies of Radio Shack software included with the Equipment or licensed separately (the "Software") meets the specifications, capacity, capabilities, versatility, and other requirements of CUSTOMER.
- B. CUSTOMER assumes full responsibility for the condition and effectiveness of the operating environment in which the Equipment and Software are to function, and for its installation.

II. RADIO SHACK LIMITED WARRANTIES AND CONDITIONS OF SALE

- A. For a period of ninety (90) calendar days from the date of the Radio Shack sales document received upon purchase of the Equipment, RADIO SHACK warrants to the original CUSTOMER that the Equipment and the medium upon which the Software is stored is free from manufacturing defects. THIS WARRANTY IS ONLY APPLICABLE TO PURCHASES OF RADIO SHACK EQUIPMENT BY THE ORIGINAL CUSTOMER FROM RADIO SHACK COMPANY-OWNED COMPUTER CENTERS, RETAIL STORES AND FROM RADIO SHACK FRANCHISEES AND DEALERS AT ITS AUTHORIZED LOCATION. The warranty is void if the Equipment's case or cabinet has been opened, or if the Equipment or Software has been subjected to improper or abnormal use. If a manufacturing defect is discovered during the stated warranty period, the defective Equipment must be returned to a Radio Shack Computer Center, a Radio Shack retail store, participating Radio Shack franchisee or Radio Shack dealer for repair, along with a copy of the sales document or lease agreement. The original CUSTOMER'S sole and exclusive remedy in the event of a defect is limited to the correction of the defect by repair, replacement, or refund of the purchase price, at RADIO SHACK'S election and sole expense. RADIO SHACK has no obligation to replace or repair expendable items.
- B. RADIO SHACK makes no warranty as to the design, capability, capacity, or suitability for use of the Software, except as provided in this paragraph. Software is licensed on an "AS IS" basis, without warranty. The original CUSTOMER'S exclusive remedy, in the event of a Software manufacturing defect, is its repair or replacement within thirty (30) calendar days of the date of the Radio Shack sales document received upon license of the Software. The defective Software shall be returned to a Radio Shack Computer Center, a Radio Shack retail store, participating Radio Shack franchisee or Radio Shack dealer along with the sales document.
- C. Except as provided herein no employee, agent, franchisee, dealer or other person is authorized to give any warranties of any nature on behalf of RADIO SHACK.
- D. Except as provided herein, **RADIO SHACK MAKES NO WARRANTIES, INCLUDING WARRANTIES OF MERCHANTABILITY OR FITNESS FOR A PARTICULAR PURPOSE.**
- E. Some states do not allow limitations on how long an implied warranty lasts, so the above limitation(s) may not apply to CUSTOMER.

III. LIMITATION OF LIABILITY

- A. EXCEPT AS PROVIDED HEREIN, RADIO SHACK SHALL HAVE NO LIABILITY OR RESPONSIBILITY TO CUSTOMER OR ANY OTHER PERSON OR ENTITY WITH RESPECT TO ANY LIABILITY, LOSS OR DAMAGE CAUSED OR ALLEGED TO BE CAUSED DIRECTLY OR INDIRECTLY BY "EQUIPMENT" OR "SOFTWARE" SOLD, LEASED, LICENSED OR FURNISHED BY RADIO SHACK, INCLUDING, BUT NOT LIMITED TO, ANY INTERRUPTION OF SERVICE, LOSS OF BUSINESS OR ANTICIPATORY PROFITS OR CONSEQUENTIAL DAMAGES RESULTING FROM THE USE OR OPERATION OF THE "EQUIPMENT" OR "SOFTWARE". IN NO EVENT SHALL RADIO SHACK BE LIABLE FOR LOSS OF PROFITS, OR ANY INDIRECT, SPECIAL, OR CONSEQUENTIAL DAMAGES ARISING OUT OF ANY BREACH OF THIS WARRANTY OR IN ANY MANNER ARISING OUT OF OR CONNECTED WITH THE SALE, LEASE, LICENSE, USE OR ANTICIPATED USE OF THE "EQUIPMENT" OR "SOFTWARE".
NOTWITHSTANDING THE ABOVE LIMITATIONS AND WARRANTIES, RADIO SHACK'S LIABILITY HEREUNDER FOR DAMAGES INCURRED BY CUSTOMER OR OTHERS SHALL NOT EXCEED THE AMOUNT PAID BY CUSTOMER FOR THE PARTICULAR "EQUIPMENT" OR "SOFTWARE" INVOLVED.
- B. RADIO SHACK shall not be liable for any damages caused by delay in delivering or furnishing Equipment and/or Software.
- C. No action arising out of any claimed breach of this Warranty or transactions under this Warranty may be brought more than two (2) years after the cause of action has accrued or more than four (4) years after the date of the Radio Shack sales document for the Equipment or Software, whichever first occurs.
- D. Some states do not allow the limitation or exclusion of incidental or consequential damages, so the above limitation(s) or exclusion(s) may not apply to CUSTOMER.

IV. RADIO SHACK SOFTWARE LICENSE

RADIO SHACK grants to CUSTOMER a non-exclusive, paid-up license to use the RADIO SHACK Software on **one** computer, subject to the following provisions:

- A. Except as otherwise provided in this Software License, applicable copyright laws shall apply to the Software.
- B. Title to the medium on which the Software is recorded (cassette and/or diskette) or stored (ROM) is transferred to CUSTOMER, but not title to the Software.
- C. CUSTOMER may use Software on one host computer and access that Software through one or more terminals if the Software permits this function.
- D. CUSTOMER shall not use, make, manufacture, or reproduce copies of Software except for use on **one** computer and as is specifically provided in this Software License. Customer is expressly prohibited from disassembling the Software.
- E. CUSTOMER is permitted to make additional copies of the Software **only** for backup or archival purposes or if additional copies are required in the operation of **one** computer with the Software, but only to the extent the Software allows a backup copy to be made. However, for TRSDOS Software, CUSTOMER is permitted to make a limited number of additional copies for CUSTOMER'S own use.
- F. CUSTOMER may resell or distribute unmodified copies of the Software provided CUSTOMER has purchased one copy of the Software for each one sold or distributed. The provisions of this Software License shall also be applicable to third parties receiving copies of the Software from CUSTOMER.
- G. All copyright notices shall be retained on all copies of the Software.

V. APPLICABILITY OF WARRANTY

- A. The terms and conditions of this Warranty are applicable as between RADIO SHACK and CUSTOMER to either a sale of the Equipment and/or Software License to CUSTOMER or to a transaction whereby RADIO SHACK sells or conveys such Equipment to a third party for lease to CUSTOMER.
- B. The limitations of liability and Warranty provisions herein shall inure to the benefit of RADIO SHACK, the author, owner and/or licensor of the Software and any manufacturer of the Equipment sold by RADIO SHACK.

VI. STATE LAW RIGHTS

The warranties granted herein give the **original** CUSTOMER specific legal rights, and the **original** CUSTOMER may have other rights which vary from state to state.

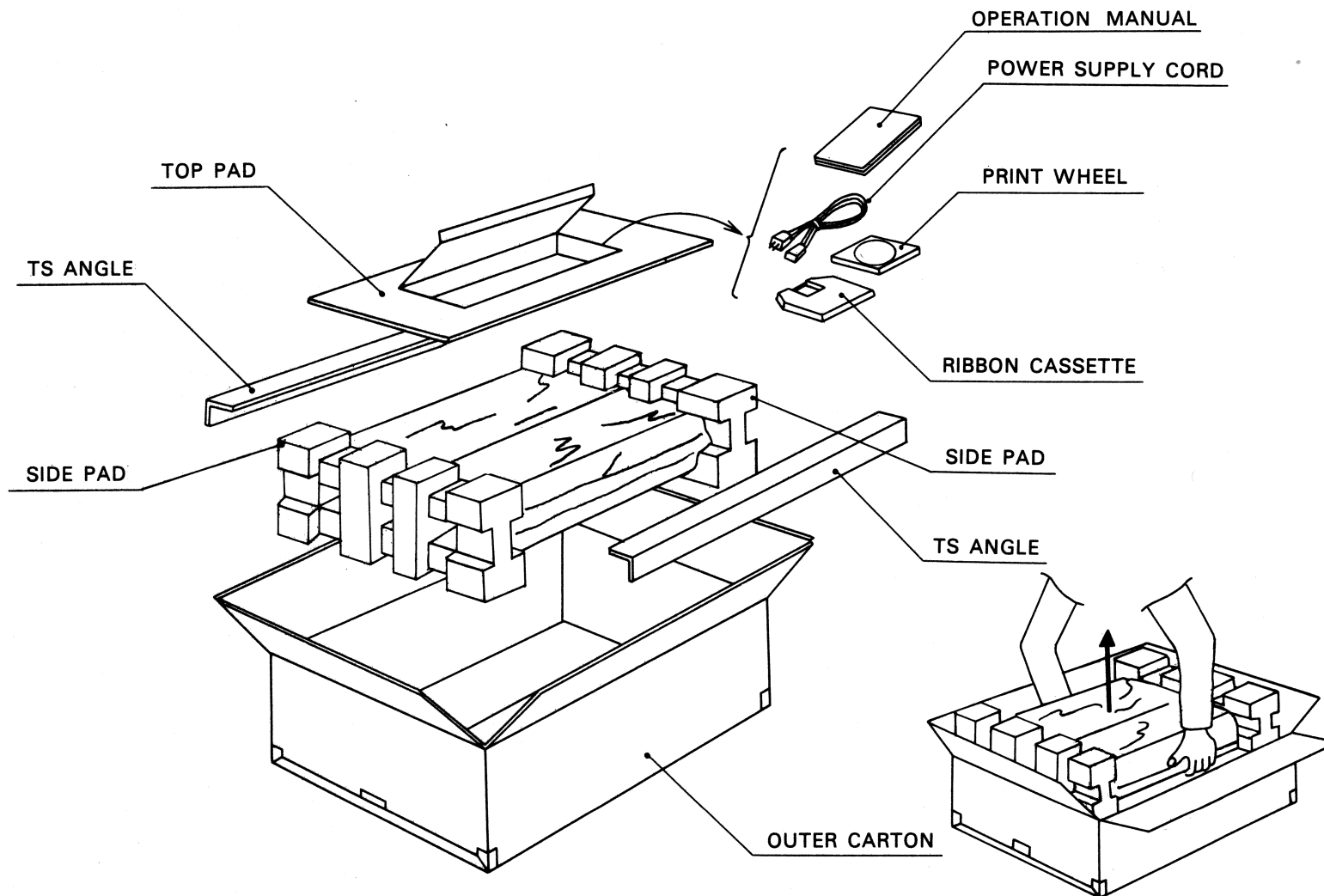

PLEASE READ USER'S MANUAL BEFORE USE.
ACCESSORIES ARE IN THE TOP PAD.

UNPACKING PROCEDURES FOR DWP-210

1. REMOVE THE TOP PAD AND TS ANGLES.
(POWER SUPPLY CORD, PRINT WHEEL, AND RIBBON CASSETTE ARE INSIDE OF THE TOP PAD.)
2. HOLD THE BOTTOM OF THE PRINTER WITH BOTH HANDS AND CAREFULLY AND SLOWLY REMOVE FROM THE OUTER CARTON. CAUTION: PLEASE, DO NOT HOLD THE KNOBS OR THE CUSHION FORMS WHEN DRAWING OUT THE PRINTER.
3. REMOVE THREE PIECES OF MASKING TAPE ON THE SILENCE COVER, THE SILENCE COVER PAD.
4. AFTER OPENING THE SILENCE COVER, REMOVE THE CARRIAGE STOPPER (2PCS.) THE PG STOPPER AND THE PWH STOPPER BETWEEN THE PW SET LEVER AND THE RIBBON BASE.
5. INSTALL THE PRINT WHEEL AND THE RIBBON CASSETTE.
6. TURN THE SILENCE COVER TOWARD YOU.

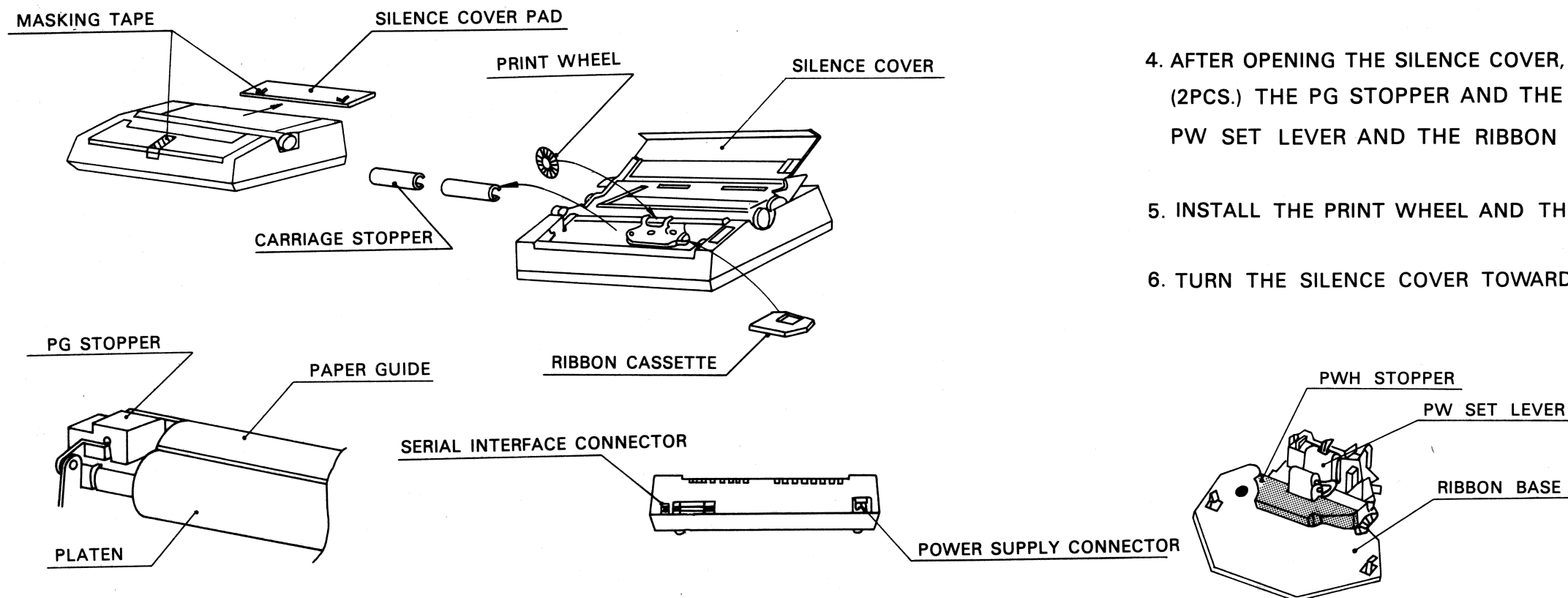

Contents

Introduction	1
1/ Description of the DWP-210	3
2/ Setting Up the DWP-210	7
Print Wheel Installation/Removal	7
Ribbon Cartridge Installation/Removal	8
Paper Loading	9
Print Position Adjustment	10
DIP Switch Setup	11
Connecting the DWP-210 to a Power Source	12
Connecting the DWP-210 to a TRS-80	12
3/ Using the DWP-210	13
Self Test	13
Setting the Pitch Select Switch	13
Control Codes and the DWP-210	13
Examples of Code Program Lines	16
External Program Mode	16
Special Functions	18
4/ Care and Maintenance	19
5/ Specifications	20
Appendix A/ Using the DWP-210 with the TRS-80	
Model II	21
Appendix B/ Tables	22
Appendix C/ Interface Description	25
Serial Interface	25
Eight-Bit Parallel Interface	27
Appendix D/ Schematic Diagrams	29
PCB Control Board Logic	29
Power Supply Logic	31
Block Diagram	32

Introduction

Congratulations for selecting the TRS-80 DWP-210! It is a daisy wheel printer designed for various applications requiring high-quality printing.

The DWP-210's special features include a:

- Wide variety of font styles, each accessible with a simple change of the Print Wheel.
- Self-test facility which lets you see if the Printer is operating properly before you begin printing.
- Automatic impact control that prolongs the Print Wheel life.
- "Paper Empty" sensor which automatically stops printing and sounds a buzzer when paper runs out.
- "Ribbon End" sensor which stops printing when the Ribbon reaches its end.
- "Cover Open" switch that prevents printing with the Front Cover open.
- Bidirectional Tractor Feed (26-1443, optional/extra) for printing on fanfold paper, and much more!

This manual will.

- Describe the DWP-210 to you.
- Show you how to set it up.
- Describe how to use the Printer in a variety of printing applications.

1/ Description of the DWP-210

When you unpack the DWP-210, be sure the package contains a:

- DWP-210
- Power Cord
- Print Wheel
- Ribbon Cartridge

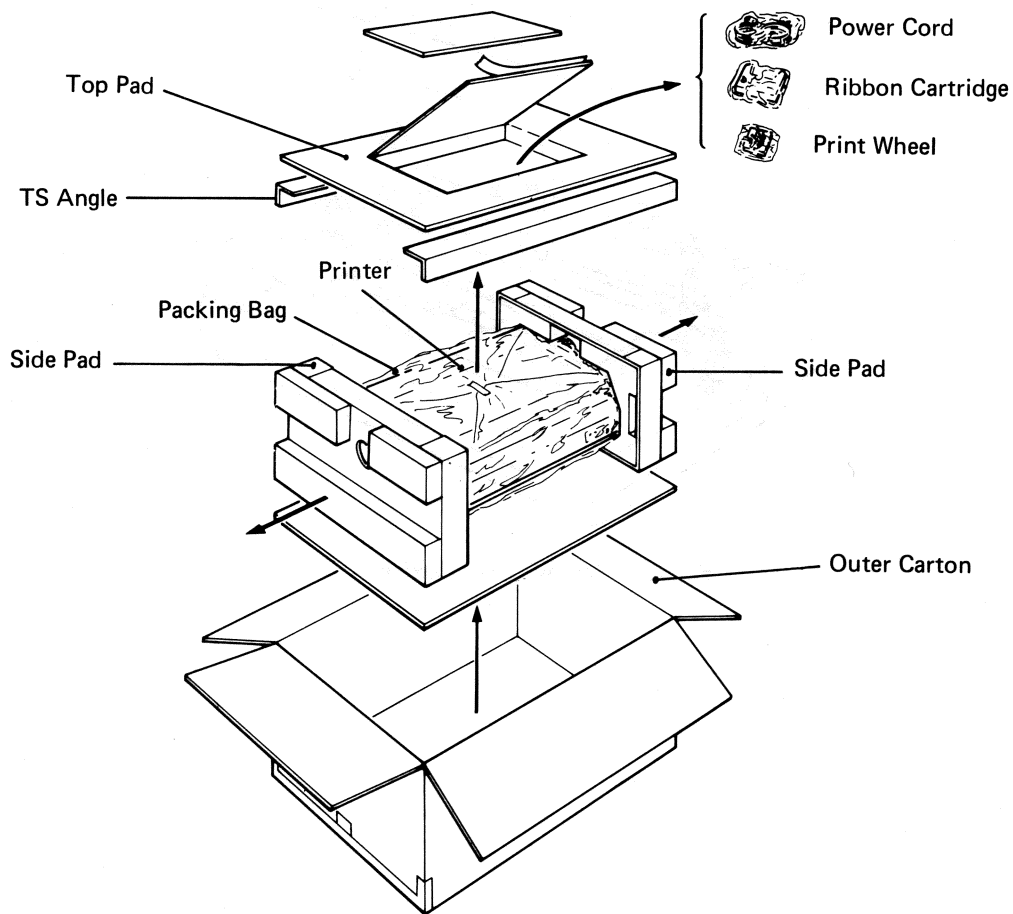

Figure 1. Unpacking the DWP-210

It is important to become familiar with the Printer before you begin using it. Study the following section carefully before setting up and using the DWP-210.

Note: When the Printer is shipped, the carrier is fixed at the left end with a brace on the carrier shaft so that the carrier does not move during transport. Remove this brace.

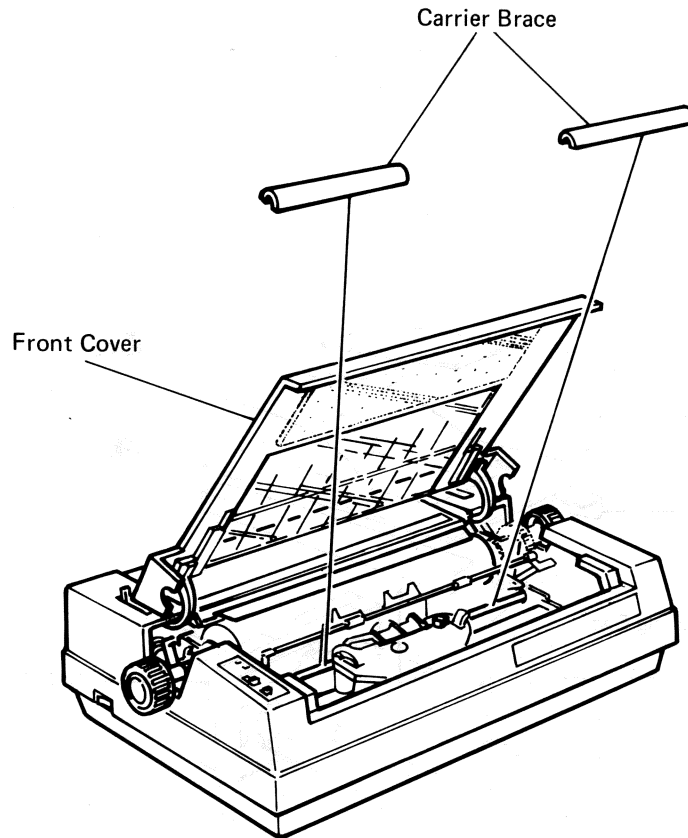

Figure 2. Removing the Carrier Brace

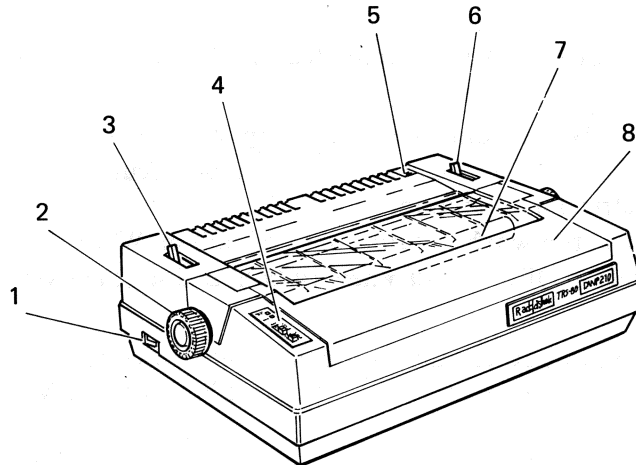

Figure 3. DWP-210 Front View

1. **Power Switch:** To turn the power ON, press the marked side of the Power Switch. Press the opposite way to turn the power OFF.

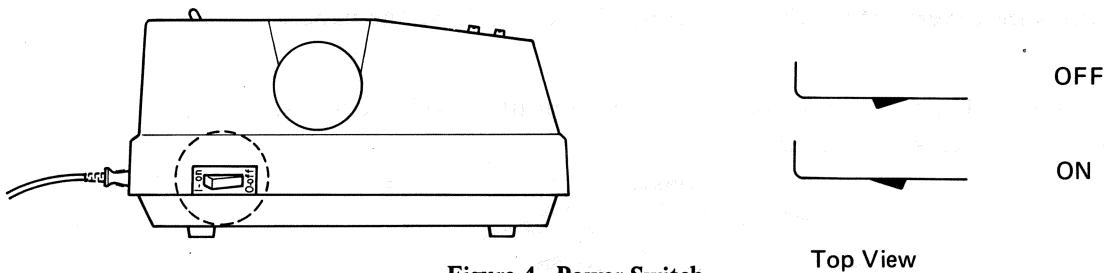
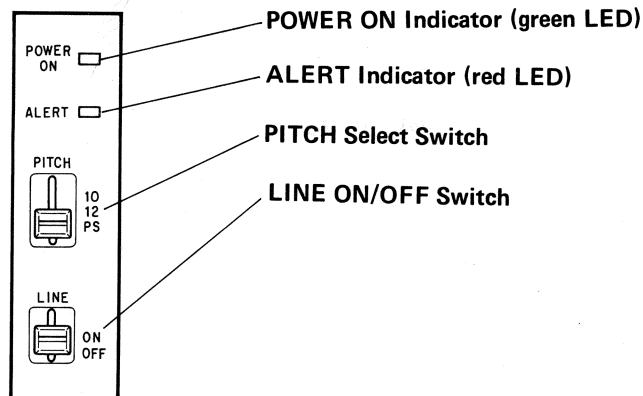

Figure 4. Power Switch

2. **Platen Knob:** Turn this knob (or the one like it on the right side) to manually advance the paper.
3. **Paper Bail Lever:** Move this lever away from you to set the Paper Bail on the paper.
4. **Operating Panel**



POWER ON Indicator (green LED): When illuminated, this lamp indicates that power is ON.

ALERT Indicator (red LED): When illuminated, this lamp indicates that a "Paper Empty," "Ribbon end," or "Cover Open" condition has occurred. It also illuminates if there is an electrical malfunction.

The Printer will automatically stop when it "runs out" of ribbon. When this occurs, set the LINE ON/OFF Switch to OFF, install a new ribbon, and set the switch back to ON.

PITCH SELECT Switch: To print 10 characters per inch, set this switch to 10; to print 12 characters per inch, set the switch to 12; to print Proportionally Spaced text, set it to PS.

LINE ON/OFF Switch: Set this switch to ON to start printing. If you have problems during printing, set to OFF. The Printer stops printing immediately, and sends a BUSY signal to the CPU. The data already received will be printed after the switch is set to ON.

5. **DIP Switch Access Cover:** Slide this cover toward the rear of the Printer to expose the DIP switch. This switch determines the initial status of the printer. Its use is explained in the next section, "Setting UP the DWP-210."

6. **Platen Pressure Lever:** Move this lever toward you to release the paper.

7. **Platen**

8. **Front Cover:** The Cover must be closed before printing will occur. Use both hands to open or close the Cover.

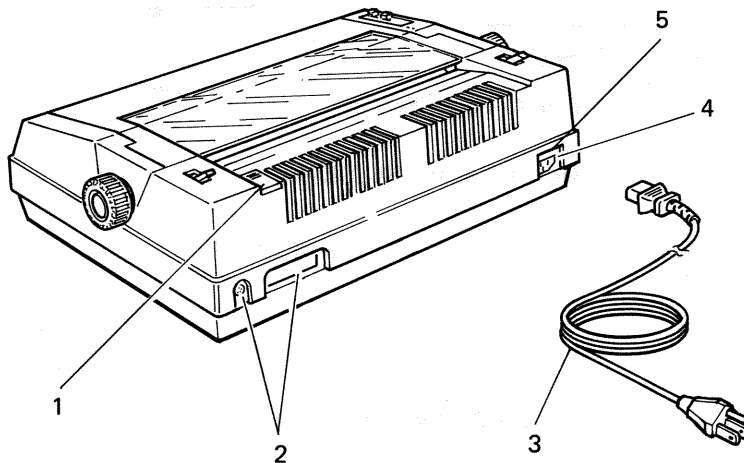

Figure 5. DWP-210 Rear View

1. **DIP Switch Access Cover**

2. **Cable Connectors:** Connect the cable from your TRS-80 to one of these connectors.

3. **Power Cord**

4. **Power Cord Connector (receptacle):** Insert one end of the power cord.

5. **Fuse Holder Cover:** When replacing the fuse, remove this cover to gain access. Use a screwdriver to remove the fuse holder. The spare fuse is placed in the rectangular box of the fuse holder.

2/ Setting Up the DWP-210

When setting up the DWP-210, be sure you select a level, sturdy location with plenty of room for easy paper flow.

Print Wheel Installation/Removal

The DWP-210 package includes a Courier 10 Print Wheel which you will need to install before printing. If you wish, you may purchase from Radio Shack a 12 pitch and/or Proportional Spaced Print Wheel for different printing operation.

Check with your local Radio Shack Computer Center or store since we are continually making more font styles available.

To install the Print Wheel

1. Open the Front Cover.
2. Remove the Ribbon Cartridge (If it is installed).
3. Pull the Wheel Lock Lever in the direction indicated by the arrow (see Figure 6A). The wheel Holder will then open.
4. Drop the Print Wheel into its Holder. (Be sure the type characters are facing the paper.)
5. Gently push the Lock Lever in the direction indicated by the arrow until it locks into place (see Figure 6B). The Wheel is set in position and ready to print.

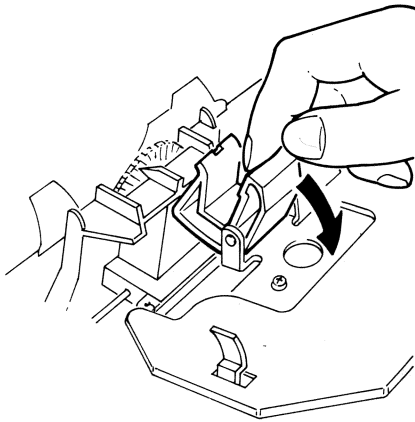

Figure 6A

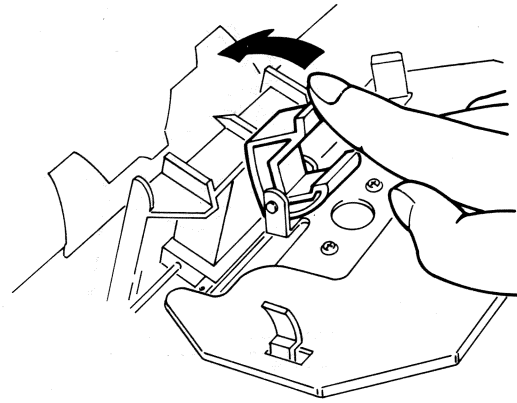

Figure 6B

To remove the Print Wheel:

1. Remove the Ribbon Cartridge.
2. Press the Wheel Lock Lever as described above (see Figure 6A).
3. Remove the Print Wheel (see Figure 6B).

Note: Replace the Print Wheel when any "petal" is broken or bent or when it becomes unusable for any reason.

Ribbon Cartridge Installation/Removal

Radio Shack sells two Ribbon Cartridges for the DWP-210 – a high-quality multi-strike Carbon Ribbon (26-1445) and a long life nylon Fabric Ribbon (26-1458). A Carbon Ribbon is included with your Printer, but no matter which Ribbon you choose to buy later on, you will find that they are both easy to install and remove.

To install a Ribbon Cartridge:

1. Before installing the Cartridge, remove all slack in the Ribbon by turning the knob on the Cartridge in the direction indicated by the arrow (counterclockwise).
2. Place the Cartridge on the carrier so that the ribbon is between the two guide plates, one each at left and right.
3. Gently press down on the Cartridge until it snaps into place.
4. Turn the knob by hand to check that the Cartridge is properly installed and that the Ribbon feeds properly.

To remove the Ribbon Cartridge:

1. Open the Front Cover.
2. Gently press the Ribbon Cartridge Hold Hooks (left and right) outward (see Figure 7).
3. Lift the end of the Cartridge with your thumb and remove the Cartridge.

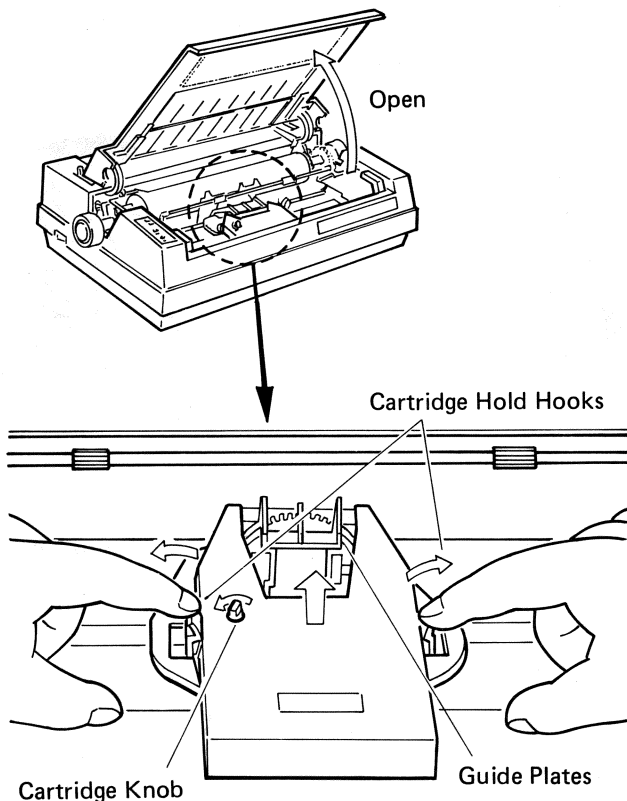

Figure 7. Installing the Ribbon Cartridge

Paper Loading

You can use either fanfold computer paper (up to 13" wide) or single-sheet typewriter paper with the DWP-210. If you use fanfold paper, you'll probably want to also use the DWP-210 Bidirectional Tractor Feed (26-1443, optional/extra) for efficient printing. For instructions on loading and using the Tractor Feed, see its operator manual. **When using single-sheet paper, you must disable the Paper Empty Detect Function by closing DIP Switch No. 3 (see "DIP Switch Setup").** Otherwise, the Printer will remain in a paper empty state, and will not start printing. When using a continuous form fanfold paper, be sure DIP Switch No. 3 is open.

1. Open the Front Cover.
2. Pull the Paper Bail Lever toward you to raise the Paper Bail.
3. Push the Platen Pressure Lever away from you to apply pressure.
4. Insert the paper with its left edge along the Paper Guide.
5. Turn the Platen Knob to advance the paper past the Paper Guide.
6. Then the paper comes out in front of the Platen, pull the Platen Pressure Lever toward you to release pressure.
7. Align and position the paper at the left margin.
8. Push the Platen Pressure Lever away from you to apply pressure.
9. Return the Paper Bail Lever to its original position.
10. Turn the Platen Knob to position the paper to the first line of printing.
See next section.

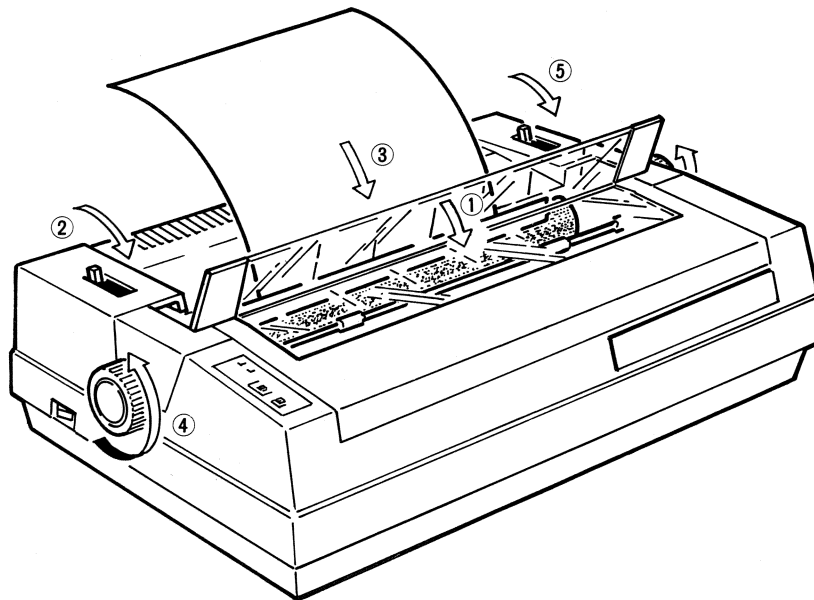

Figure 8. Paper Loading

Print Position Adjustment

After loading the paper, align the paper position in relation to the Paper Deflector as shown below:

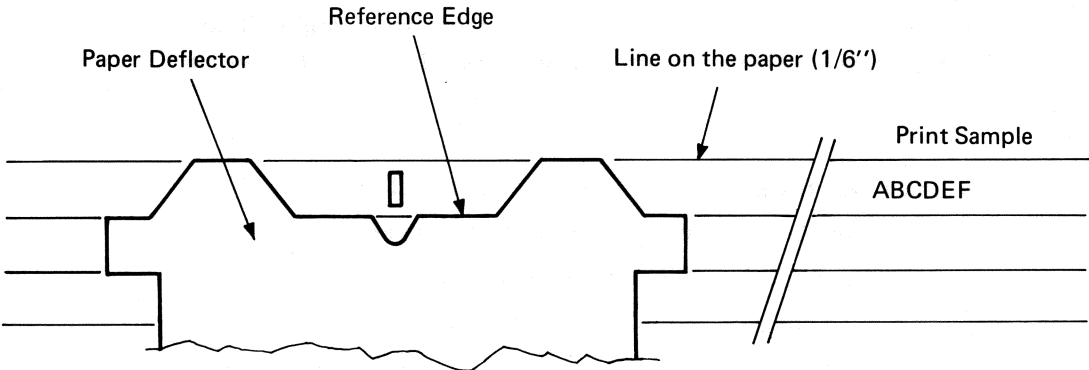

Figure 9. Print Position

DIP Switch Setup

The DIP Switch is located on the printer control PC board; open the DIP Switch Access Cover at the rear of the DWP-210 to change the setting. The selections with the DIP Switch are listed below:

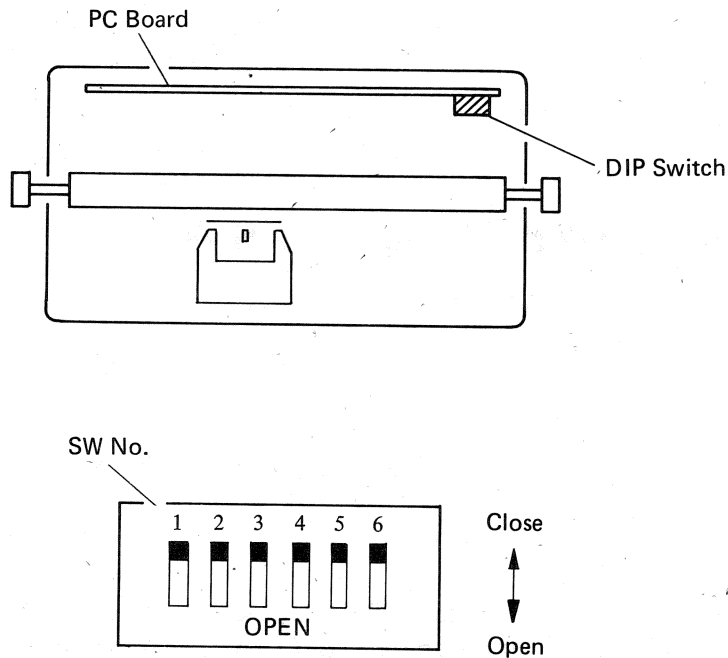

Figure 10. DWP-210 DIP Switch Settings

Switch No.	Function	OPEN	CLOSE
1	Interface	Serial	8-bit parallel
2	Baud rate	1200 bps	600 bps *
3	Paper empty switch	Enable	Disable
4	Impact	Low	High
5	Self test	Not applied	Applied
6	Auto logic seek	Applied	Not applied

The DIP Switch determines the initial status of the Printer at power ON (except Switch No. 4). Therefore, be sure to set the switches when the power is OFF!

Auto Logic Seek:

The Printer automatically performs bidirectional logic-peek printing for maximum efficiency when DIP Switch No. 6 is set to the OPEN side and data for one line ends with a CR code. Character codes, space code, and CR code are handled in logic-peek mode, but other codes are not.

*Note: Use the Serial Interface only when the DWP-210 is connected to a Color Computer.

Connecting the DWP-210 to a Power Source

Always be sure the DWP-210 is connected to a grounded wall-outlet or grounded approved power strip, such as Radio Shack's Plug-In Power Strip (61-2619) or the Automatic Power Controller Model SW-301 (26-1429).

Always use the supplied cord when connecting the DWP-210 to a power source. Before inserting the Power plug, make sure that the Power Switch is OFF.

1. Plug one end of the cord into the connector on the rear of the Printer.
2. Plug the other end of the cord into an approved power source.

Connecting the DWP-210 to a TRS-80

The DWP-210 can be used with any TRS-80 Computer or Data Terminal that has Printer Interface capabilities. This includes:

- Model I
- Model II
- Model III
- Model 16
- Color Computer

However, before connecting the Printer to a TRS-80, be sure you have the correct cable. The following tables list the appropriate Radio Shack cables and the location of the connection points on each TRS-80's, respectively.

Printer to Computer Cables	
TRS-80	Cable catalog number
Model I/III Model II/16	26-1401 26-4401
Color Computer	26-3020

TRS-80 Connection Locations	
TRS-80	Location
Model I Model II/16 Model III	Left side of E.I. Rear Panel Lower Panel
Color Computer	Rear Panel

1. Connect one end of the appropriate cable to the Interface connector on the DWP-210.
2. Connect the other end of the cable to the TRS-80.

3/ Using the DWP-210

Once the DWP-210 is properly installed and correctly set up, you can begin using it.

Self Test

Perform the Self Test to insure that the Printer is operating properly, **Do not perform the Self Test unless the Printer is loaded with wide (10") paper, since the Test prints the full width of the Platen. Printing directly on the Platen can shorten the life of the Print Wheel and the Platen.** Self Test is performed in 600 baud mode only. Be sure you've set the DIP Switch No. 2 to CLOSE.

1. Turn the Power Switch ON.
2. Make sure that the Carriage returns to the left position.
3. Turn the Power Switch OFF.
4. Set DIP Switch No. 5 to CLOSE.
5. Turn the Power Switch ON. A Print Wheel index test is conducted automatically. (The Print Wheel turns clockwise ten times.)
6. Test printing follows and continues until the Power Switch is turned OFF.
7. Be sure to OPEN DIP Switch No. 5 after the test.

Setting the Pitch Select Switch

Be sure to set the Pitch Select Switch (on the Operating Panel) to the position that corresponds to the Print Wheel you are using. That is, if you are using a Courier 10-pitch Wheel, for example, set the Switch to 10; if you are using a Proportional Space Wheel, set the Switch to PS.

Do not accidentally bump the Pitch Select Switch during printing. Unless you change the pitch via software, the current switch setup remains in effect. Once you change the pitch via software, you must turn the Power Switch off before you can use the Pitch Select Switch.

Control Codes and the DWP-210

Before using the DWP-210, consider how the TRS-80 communicates with the Printer.

All information is sent to the Printer as numbers between 0 and 255 decimal (00-FF for you hexadecimal fans). The Printer interprets these numbers according to the Modified ASCII Code (listed in Appendix B). Most numbers (or codes) are printed as letters, numbers, or symbols. However, the numbers 0-31 decimal, as well as some special sequences of code numbers, are used to "control" various functions of the Printer. These "Control Codes" allow you to control line feeds, backspacing, underlining, etc.

Sending Control Codes from BASIC

Some Printer features are activated by a single code, but many functions require a sequence of two or more codes. Most multiple code sequences begin with decimal 27 (referred to as the "ESCape" code). The ESC code notifies the Printer that a special sequence is on its way. The next code(s) sent determine which Printer feature is selected. In BASIC, use CHR\$ () to send these codes to the Printer.

For instance, set up the DWP-210 as described earlier and enter BASIC in the normal way. Then type the following short program:

```
10 LPRINT CHR$ (15); "UNDERLINE" CHR$ (14); "NO UNDERLINE"
and RUN it.
```

Roll the paper forward and look at the results. The word UNDERLINE was underlined and the words NO UNDERLINE were not underlined. Why? The codes CHR\$ (15) and CHR\$ (14) are the guilty parties. Take a quick look at the following chart. This chart shows the various code sequences understood by the DWP-210.

DWP-210 Control Codes

Mnemonic	Code		Function
	Hexa- decimal	Decimal	
LF	0A	10	Feeds the paper by one line at a time. The line spacing is 1/6".
CR	0D	13	Effects Carriage Return and Line Feed in normal mode. However, if the Printer receives this code after 27 21, it performs only Carriage Return. Returns to normal mode when a 27 22 is received.
SP	20	32	Moves the Carriage one character position. However, two or more SP codes received in succession do not cause successive spacing, but they do effect high-speed tabulation. The Carriage moves even if no character data is received within 50 ms after an SP code.
SO	0E	14	Ends the automatic underline print function. The Printer is in this mode when you turn it on.
SI	0F	15	Starts the automatic underline print function. Characters except space are underlined.
ESC SO	1B 0E	27 14	Sets the character spacing to 1/12" pitch. It overrides the Pitch Select Switch setup.

— continued —

Mnemonic	Code		Function
	Hexa-decimal	Decimal	
ESC SI	1B 0F	27 15	Sets the character spacing to 1/10" pitch. It overrides the Pitch Select Switch setup.
ESC DC1	1B 11	27 17	Places the Printer in Proportional Space Mode. It overrides the Pitch Select Switch setup.
ESC NAC	1B 15	27 21	Once this code is received, code 13 effects only Carriage Return. This condition continues until 27 22 code is received.
ESC SYN	1B 16	27 22	Once this code is received, code 13 effects Carriage Return and Line Feed. The Printer enters this mode when you turn it on.
ESC CAN	1B 18	27 24	Enters External Program mode (to be described later).
ESC EM	1B 19	27 25	Exits External Program mode (to be described later).
BS(n)	08 n	08 n	Backspaces the Carriage n number of micro-spaces. The values this byte can assume, 0 through 255, correspond to 0/120 through 255/120 inches respectively. If the data specifies the Carriage to move beyond the home position (left side), the Printer ignores the data and moves the Carriage to the home position.
ESC(n)	1B n	27 n	Advances the Carriage n number of micro-spaces. The values this byte can assume, 0 through 9, correspond to 0/120 through 9/120 inches, respectively. If the data specifies the Carriage to move beyond the right margin, the Printer simply performs Carriage Return and Line Feed.
ESC SUB	1B 1A	27 26	1/48 inch Line Feed.
ESC FS	1B 1C	27 28	Half Line Feed.
ESC RS	1B 1E	27 30	Reverse Half Line Feed.
ESC LF	1B 0A	27 10	Reverse Line Feed.

Examples of Code Program Lines

LPRINT CHR\$ (8); CHR\$ (1)

Backspaces 1/120".

LPRINT CHR\$ (13)

Returns Carriage with Line Feed.

LPRINT CHR\$ (27); CHR\$ (3)

Moves 3/120" space.

LPRINT CHR\$ (27); CHR\$ (14)

All subsequent characters will be printed at 12 pitch.

LPRINT CHR\$ (27); CHR\$ (17)

All subsequent characters will be printed in Proportional Spacing.

External Program Mode

On some special Print Wheels, you'll need to "externally" control the:

- Spacing between Proportional Spaced characters.
- Ribbon feed
- Printing impression level.

The Print Wheels that require external programming will be labeled "Require Special Programming" on the packaging material. Each Print Wheel package will contain external programming code information.

To enter External Program Mode, send a CHR\$ (27); CHR\$ (24). Then send a two-byte code for each character or symbol.

- The first byte is the ASCII code for the character.
- The second byte contains the data specifying the printing format (e.g. Printing Impression Level, Ribbon Feed and Pitch).

Important Note! This must be done for each and every character during External Program Mode or an error will occur.

Table A describes Printing Impression Levels, and Table B details spacing between Proportional Spaced characters. Ribbon feed is normal at 0, increased at 1. Note that these tables list binary values. You'll need to combine the binary values and then convert the binary values (using the Base Conversion Chart in your TRS-80 owner's or reference manual) to a decimal value. Then send that decimal value to the Printer with CHR\$ ().

For example, suppose the letter T requires 1/10" (=6/60") spacing and Printing Impression Level 4.

Looking at Table B, you'll see the 1/10" spacing is binary 0110. Table A shows that Printing Impression Level 4 is binary 100. Adding these values together produces that binary value of 01101100 (0110 + 1 + 100 = 01101100) or 01100100 (0110 + 0 + 100). By referring to your Base Conversion Chart in a TRS-80 owner's or reference manual, you'll see that binary 001101100 is equal to decimal 108 or 001100100 is equal to 100. Therefore, if you send a CHR\$ (84); CHR\$ (108) or CHR\$ (84); CHR\$ (100) to the DWP-210, the letter T will be printed.

These code numbers will be provided with each Print Wheel package.

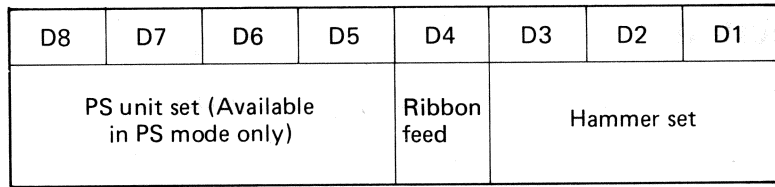

Unit amount (A/60'')	D8	D7	D6	D5
0 (print without Carriage movement)	0	0	0	0
1	0	0	0	1
2	0	0	1	0
3	0	0	1	1
4	0	1	0	0
5	0	1	0	1
6	0	1	1	0
7	0	1	1	1
8	1	0	0	0
9	1	0	0	1
10	1	0	1	0
11	1	0	1	1
12	1	1	0	0
13	1	1	0	1
14	1	1	1	0
15	1	1	1	1

Table B

Hammer impression level	D3	D2	D1
0	0	0	0
1	0	0	1
2	0	1	0
3	0	1	1
4	1	0	0
5	1	0	1
6	1	1	0
(no hammer action)	1	1	1

Table A

Example

```

10 LPRINT CHR$ (27); CHR$ (24); 'ENTERS EXTERNAL PROGRAM
20 LPRINT CHR$ (84); CHR$ (108); 'PRINT T
30 LPRINT CHR$ (97); CHR$ (107); 'PRINT a
40 LPRINT CHR$ (110); CHR$ (107); 'PRINT n
50 LPRINT CHR$ (100); CHR$ (108); 'PRINT d
60 LPRINT CHR$ (121); CHR$ (107); 'PRINT y

```

Special Functions

When using the DWP-210, you should be aware that there are special functions available.

Auto NL (New Line):

The Printer performs Carriage Return and Line Feed upon receiving a code to move the Carriage beyond the right margin.

Auto Logic Seek:

The Printer automatically performs bidirectional logic-peek printing for maximum efficiency when DIP Switch No. 6 is set to the OPEN side and data for one line ends with a CR code. Character codes, space code, and CR code are handled in logic-peek mode, but other codes are not.

4/ Care and Maintenance

Except for ordinary setup and cleaning, maintenance work should be performed only by a qualified service technician.

Of course, you can and should perform standard cleaning procedures just as you would with any office typewriter. Clean the Platen, Print Wheel, and other parts with standard typewriter cleaning fluid (use a soft, lint-free cloth).

Some do's and don'ts to assure maximum performance and reliability from your Printer:

DO	DON'T
Plug power cord into 3-wire grounded outlet.	Operate Printer in environments of high dust or dirt content, high temperature or humidity.
Position Printer on a firm, flat, clean surface.	Place any object on any part of Printer (if anything falls inside the Printer, turn Printer power off and carefully remove the object).
Use only a lint-free cloth to clean Printer Case. Mild detergent solution can be used sparingly.	Use alcohol, solvents or harsh cleaning agents on any part of the Printer.
Insure that all covers are closed and secured before operating.	Operate Printer without paper (if paper less than 13" wide, take care not to print lines too long for the paper).
Turn off power before making any adjustment.	

TROUBLESHOOTING

If the Printer fails to operate properly, try to solve the problem as follows:

1. Power ON Indicator does not turn on.
 - Check to see if the AC cord is plugged securely into appropriate power source.
 - Check the fuse. If blown, replace with the one of the same type/rating.
2. No communication with TRS-80.
 - Check to see if the interface cable is properly connected.
 - Check to see if the Line ON/OFF switch is ON.
3. Printer will not print.
 - Insure that the Front Cover is closed.
 - Check and change Ribbon if necessary.
 - Perform Self Test to insure the Printer is internally capable of printing.
 - Insure that the Print Wheel is locked into position.
 - Check if anything has fallen into the mechanism that is physically obstructing the Carriage movement.

5/ Specifications

Printing speed	200 WPM (with Radio Shack standard text at 10 pitch) 18 cps (with Shannon Text at 10 pitch)
Printing method	Static font impact printing
Print line	11.5 inches (115 columns for 10 pitch or 138 columns for 12 pitch)
Character spacing	1/120 inch (minimum)
Line spacing	1/48 inch (minimum)
Carriage return speed	11.5 inches per second
Form width	Up to 13 inches
Copies	Original plus 2 copies Total thickness – 0.2 mm or less 3 copies – 15 or 20 lb non-carbon paper 2 copies – 15 or 20 lb carbon paper
Ribbon	Multi-strike carbon (Catalog Number 26-1445) or nylon fabric (Catalog Number 26-1458)
Character set	100 characters
Print Wheel	100-character plastic daisy wheel
Interface	RS232C 600/1200 bps Protocol – DTR 8-bit parallel – Tandy Standard Interface
Power requirement	120 VAC \pm 15 V, 60 Hz 220 VAC \pm 22 V, 50 Hz (for the units purchased in Europe) 240 VAC \pm 24 V, 50 Hz (for the units purchased in UK/Australia)
Environment	
Operating	Temperature – 32°F to 95°F (0°C to 40°C) Relative humidity – 20% to 90%
Storage	Temperature – -40°F to 160°F (-40°C to 71°C) Relative humidity – 5% to 95%
Noise emission	62 dB (front), 67 dB (rear) or less (measured with A scale 1 meter front the Printer)
Dimensions	6.3" high x 20" wide x 13.7" deep
Weight	36 lbs (16 kg)
Buffer capacity	192 bytes
Sensors	Ribbon End photoelectric sensor Paper Empty detect switch Cover Open detect switch

Appendix A/ Using the DWP-210 with the TRS-80 Model II

To use the DWP-210 with SCRIPSIT, type (at TRSDOS READY):

```
PATCH SCRIPSIT/SYS (R=175 B=22 F=0F C=FF) <ENTER>
```

You will also have to adjust the character width and the backspace distance. See the SCRIPSIT 2.0 reference manual for details.

Instead of the above procedure, users of SCRIPSIT 2.1 can use the PRTPCH program provided with it. Answer the prompts for the DWP-410 (this is code-compatible with the DWP-210).

TRSDOS-II Users:

To use SCRIPSIT, type (at TRSDOS-II Ready):

```
DO DWP410 <ENTER>
```

Several PATCH COMPLETE message will appear. To remove these patches so that you can use other printers, type:

```
DO UNDWP410 <ENTER>
```

Note: If you are using TRSDOS-II on a hard disk system, you will need to insert your SCRIPSIT installation diskette into Drive 0 before doing the above patches.

Appendix B/ Tables

Table 1: Modified ASCII Code Chart

Code			Char.	Code			Char.	Code			Char.	Code			Char.
Dec.	Hex	Oct.		Dec.	Hex	Oct.		Dec.	Hex	Oct.		Dec.	Hex	Oct.	
32	20	40	(Space)	64	40	100	@	96	60	140	\	167	A7	247	'
33	21	41	!	65	41	101	A	97	61	141	a	169	A9	251	TM
34	22	42	"	66	42	102	B	98	62	142	b	170	AA	252	®
35	23	43	#	67	43	103	C	99	63	143	c	171	AB	253	©
36	24	44	\$	68	44	104	D	100	64	144	d	222	DE	336	¢
37	25	45	%	69	45	105	E	101	65	145	e				
38	26	46	&	70	46	106	F	102	66	146	f				
39	27	47	'	71	47	107	G	103	67	147	g				
40	28	50	(72	48	110	H	104	68	150	h				
41	29	51)	73	49	111	I	105	69	151	i				
42	2A	52	*	74	4A	112	J	106	6A	152	j				
43	2B	53	+	75	4B	113	K	107	6B	153	k				
44	2C	54	,	76	4C	114	L	108	6C	154	l				
45	2D	55	—	77	4D	115	M	109	6D	155	m				
46	2E	56	.	78	4E	116	N	110	6E	156	n				
47	2F	57	/	79	4F	117	O	111	6F	157	o				
48	30	60	0	80	50	120	P	112	70	160	p				
49	31	61	1	81	51	121	Q	113	71	161	q				
50	32	62	2	82	52	122	R	114	72	162	r				
51	33	63	3	83	53	123	S	115	73	163	s				
52	34	64	4	84	54	124	T	116	74	164	t				
53	35	65	5	85	55	125	U	117	75	165	u				
54	36	66	6	86	56	126	V	118	76	166	v				
55	37	67	7	87	57	127	W	119	77	167	w				
56	38	70	8	88	58	130	X	120	78	170	x				
57	39	71	9	89	59	131	Y	121	79	171	y				
58	3A	72	:	90	5A	132	Z	122	7A	172	z				
59	3B	73	;	91	5B	133	[(†)	123	7B	173	{				
60	3C	74	<	92	5C	134	\ (‡)	124	7C	174					
61	3D	75	=	93	5D	135] (←)	125	7D	175	}				
62	3E	76	>	94	5E	136	^ (→)	126	7E	176	~				
63	3F	77	?	95	5F	137	— (—)	166	A6	246	°				

Note 1: Printer ignores 127 and 255. Other undefined codes are converted into a space code (32 Dec.).

Note 2: If an undefined code is contained in an ESC (27 Dec.) sequence, the Printer ignores the ESC sequence.

Table 2: Print Wheel Arrangement

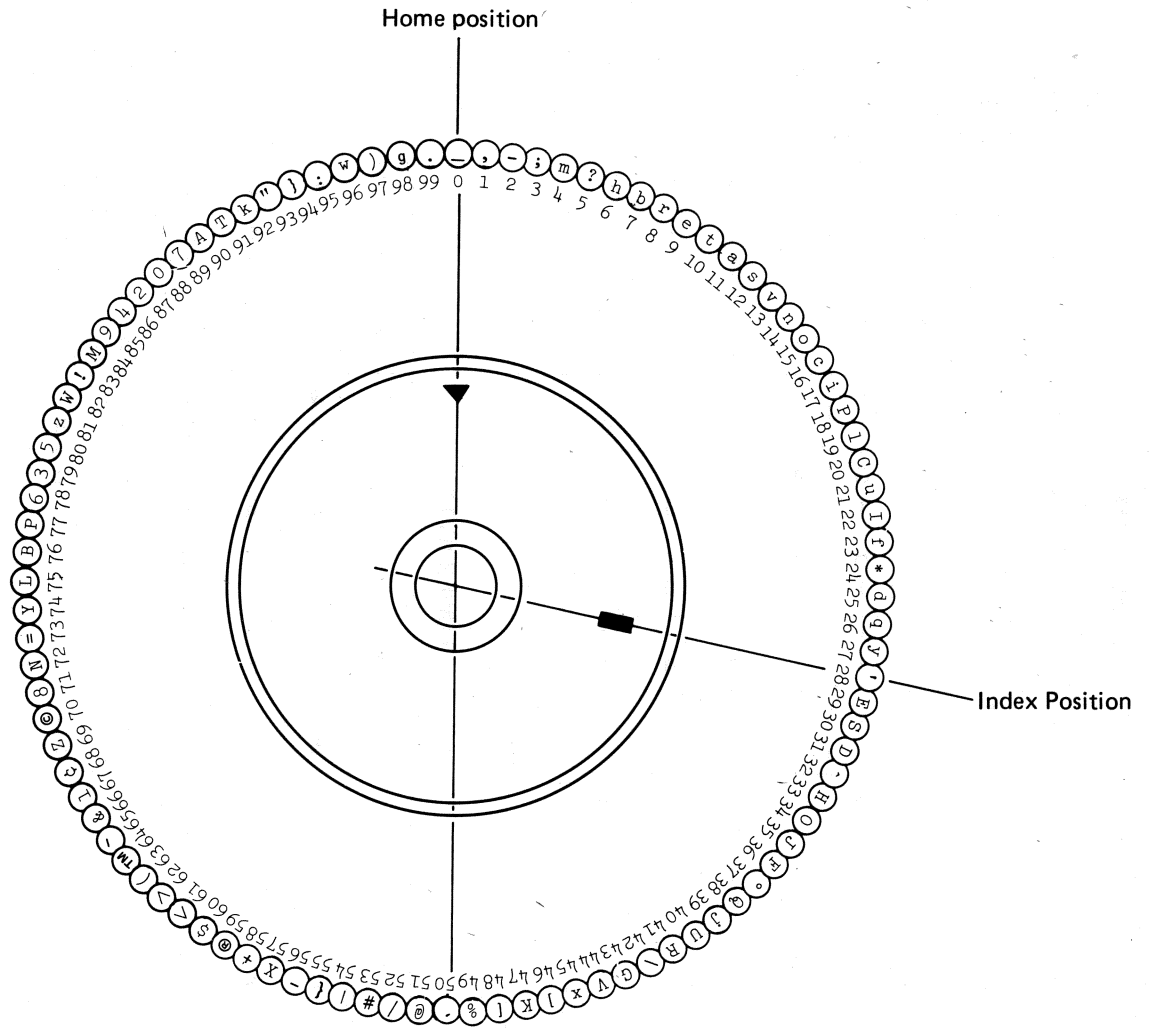

Table 3: Hammer Energy Data

		UPPER BYTE							A	D
LOWER BYTE	0	2	3	4	5	6	7	/	/	
	1	!	1	A	Q	a	q	/	/	
	2	"	2	B	R	b	r	/	/	
	3	#	3	C	S	c	s	/	/	
	4	\$	4	D	T	d	t	/	/	
	5	%	5	E	U	e	u	/	/	
	6	&	6	F	V	f	v	°	/	
	7	'	7	G	W	g	w	'	/	
	8	(8	H	X	h	x	/	/	
	9)	9	I	Y	i	y	TM	/	
A	*	:	J	Z	j	z	®	/		
B	+	;	K	[k		©	/		
C	,	<	L	\	l		/	/		
D	.	=	M]	m		/	/		
E	.	>	N		n	~	/	¢		
F	/	?	O	-	o	(DEL)	/	/		

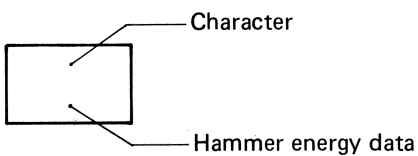
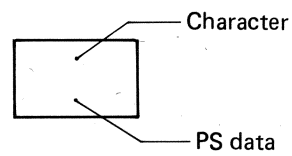

Table 4: Proportional Spacing Data

		UPPER BYTE							A	D
LOWER BYTE	0	2	3	4	5	6	7	/	/	
	1	!	1	A	Q	a	q	/	/	
	2	"	2	B	R	b	r	/	/	
	3	#	3	C	S	c	s	/	/	
	4	\$	4	D	T	d	t	/	/	
	5	%	5	E	U	e	u	/	/	
	6	&	6	F	V	f	v	°	/	
	7	'	7	G	W	g	w	'	/	
	8	(8	H	X	h	x	/	/	
	9)	9	I	Y	i	y	TM	/	
A	*	:	J	Z	j	z	®	/		
B	+	;	K	[k		©	/		
C	,	<	L	\	l		/	/		
D	.	=	M]	m		/	/		
E	.	>	N	^	n	~	/	¢		
F	/	?	O	-	o	(DEL)	/	/		



Appendix C/ Interface Description

Serial Interface

To select RS232C serial interfacing, set DIP Switch No. 1 to the OPEN side.
The data transmission speed is 600 or 1200 bps, selectable with DIP Switch No. 2,
The Data Protocol is based on DTR.

Synchronization:

- Start bit: 1 bit
- Stop bit: 1 or 2 bits
- Word length: 8 bits
- Parity: None

Error Detection:

The Printer can detect a framing error which means that no stop bit is present in the frame specified by the start bit. When a framing error is detected, a "@" is printed. In two-stop-bit mode, the Printer checks only the first stop bit, not the second one.

Interface Connector and Pin Arrangement

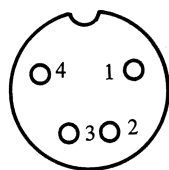

Pin No.	
1	Not used
2	BUSY
3	Ground (0 V)
4	DATA

Interface Signals:

- BUSY High – Printer is ready to receive data from the Host Processor.
Low – Host Processor must stop transmitting data to the Printer.
- GND Signal ground (0 V)
- DATA Carries serial data in ASCII from the Host Processor to the Printer. When no character is transmitted, this line must be in mark-hold condition. Negative Logic applies.

Cable Length: Up to 15 meters.

Interface Protocol:

The Printer has a first-in/first-out data buffer. If the Host Processor continues to transmit data without regard for the feedback signal (BUSY) from the Printer, data could be lost.

1. The Host Processor checks the Printer status line (BUSY). If it is high, the Host Processor starts sending data.
2. Upon detecting the start bit, the Printer sets the BUSY line to low.
3. After receiving and processing data, the Printer sets the BUSY line to high.

Busy state:

The Printer is in BUSY state upon detecting the following:

- Buffer Full
- Off-line
- Ribbon End
- Paper Empty
- Cover Open
- Initialization (power ON)

Eight-Bit Parallel Interface

To select 8-bit parallel interfacing, set DIP Switch No. 1 to CLOSE.

Pin Arrangement:

Pin	1	$\overline{\text{DATA STROBE}}$	19	TWISTED PAIR GND
	2	DATA 1	20	"
	3	DATA 2	21	"
	4	DATA 3	22	"
	5	DATA 4	23	"
	6	DATA 5	24	"
	7	DATA 6	25	"
	8	DATA 7	26	"
	9	DATA 8	27	"
	10	$\overline{\text{ACK}}$	28	"
	11	BUSY	29	"
	12	PE	30	GND
	13	$\overline{\text{BUSY}}$	31	NC
	14	GND	32	$\overline{\text{FAULT}}$
	15	NC	33	NC
	16	GND	34	NC
	17	CHASSIS GND	35	NC
	18	+ 5 V	36	NC

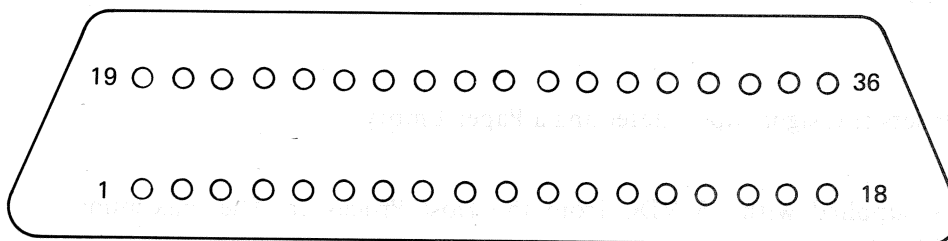

Note: Pins denoted by NC are pulled up to +5V via a 10 k resistor.

Interface Signals:

- **DATA 1-8**

Carries data bits 1-8. Positive logic applies. Each line is coupled with a Schmitt inverter, and connected to +5V via a 1 k resistor.

- **$\overline{\text{DATA STOROE}}$**

Determines when to receive data. When this signal changes from low to high, the data is latched. This signal line is coupled with the TTL input, grounded via 33 pF, and connected to +5 V via a 1 k resistor.

- **$\overline{\text{ACK}}$**

Sent to the Host Processor. The Leading edge of this signal indicates that the Printer is no longer busy.

- **BUSY**

When high, this signal indicates that the Printer is busy. If the Host Processor continues to transmit data without regard to this signal high, data could be lost.

The printer sets BUSY high upon detecting the following:

- Input Buffer Full
- Receive Buffer Full
- Off-line
- Ribbon End
- Paper Empty
- Cover Open
- Initialization (power ON)

- **$\overline{\text{BUSY}}$**

This signal is a logical inversion of BUSY.

- **$\overline{\text{FAULT}}$**

When low, this signal indicates that the Printer is in one of the following fault statuses:

- Ribbon End
- Paper Empty
- Cover Open
- Off-line

- **PE**

The Printer sets this signal upon detecting a Paper Empty.

- **+5 V**

This pin is supplied with +5 VDC from the Host Processor. The maximum current is 80 mA.

Cable Length: Up to 5 meters (twisted pair).

Appendix D/ Schematic Diagrams

PCB: Control Board Logic

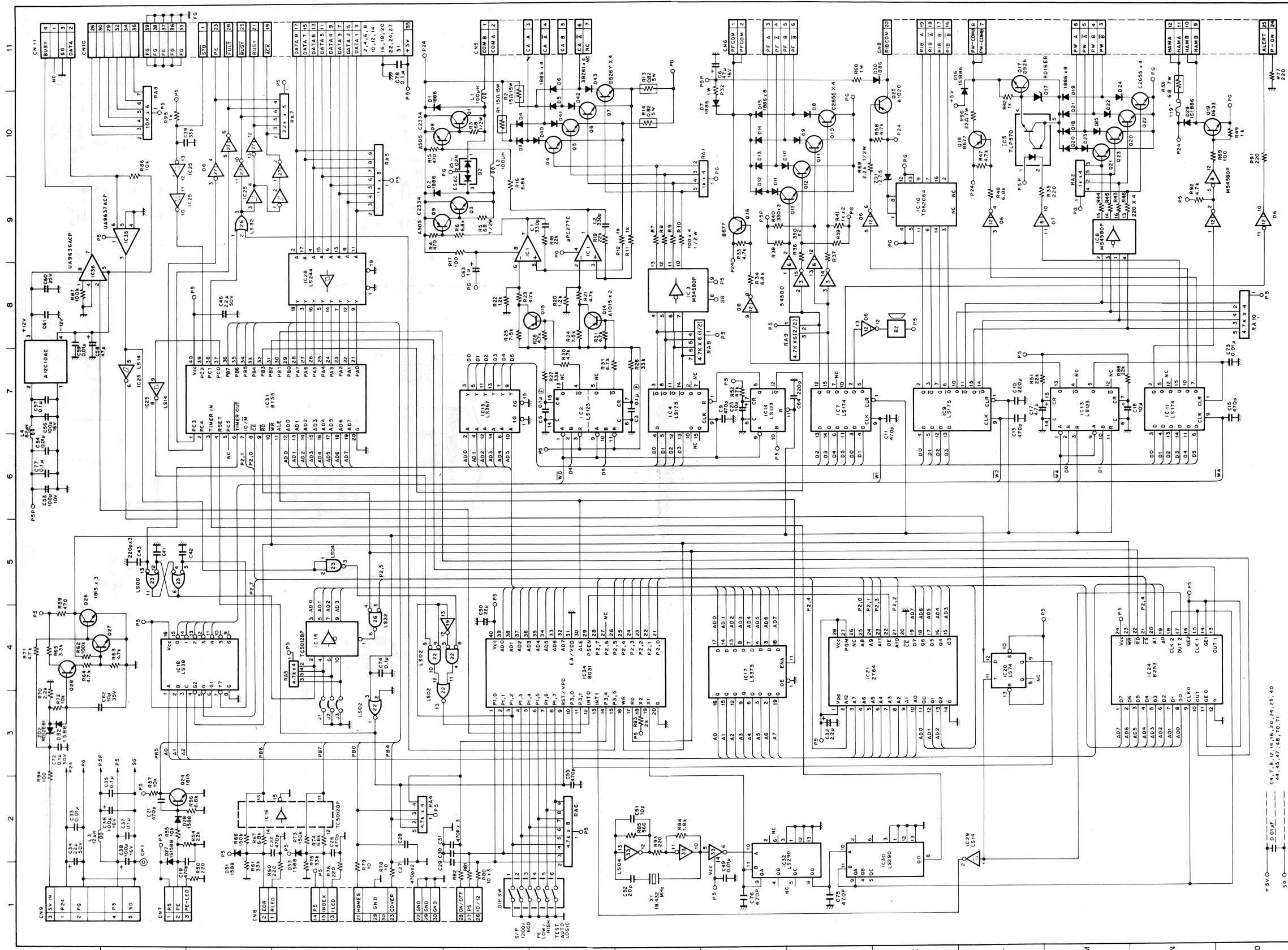

Power Supply Logic

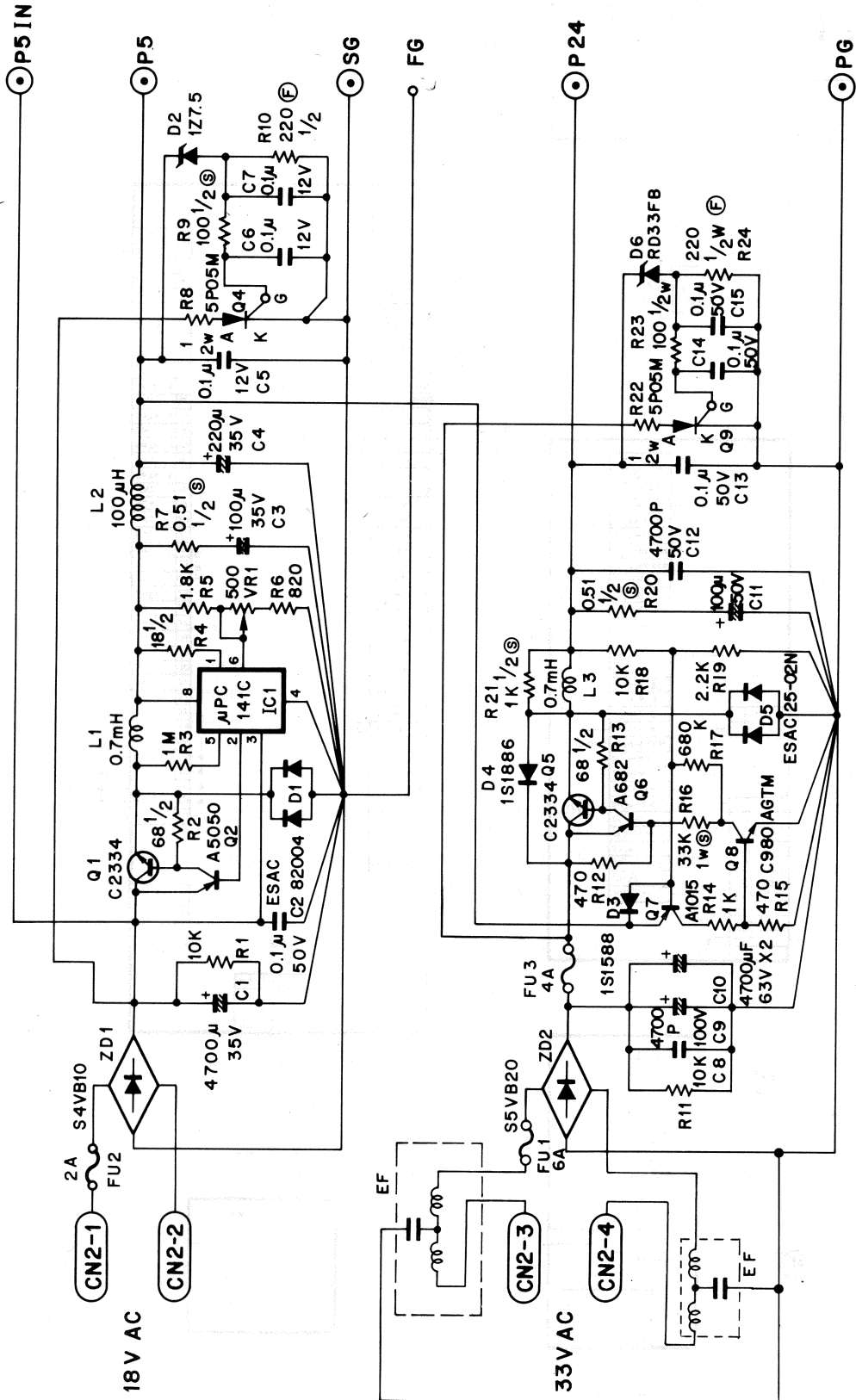

Block Diagram

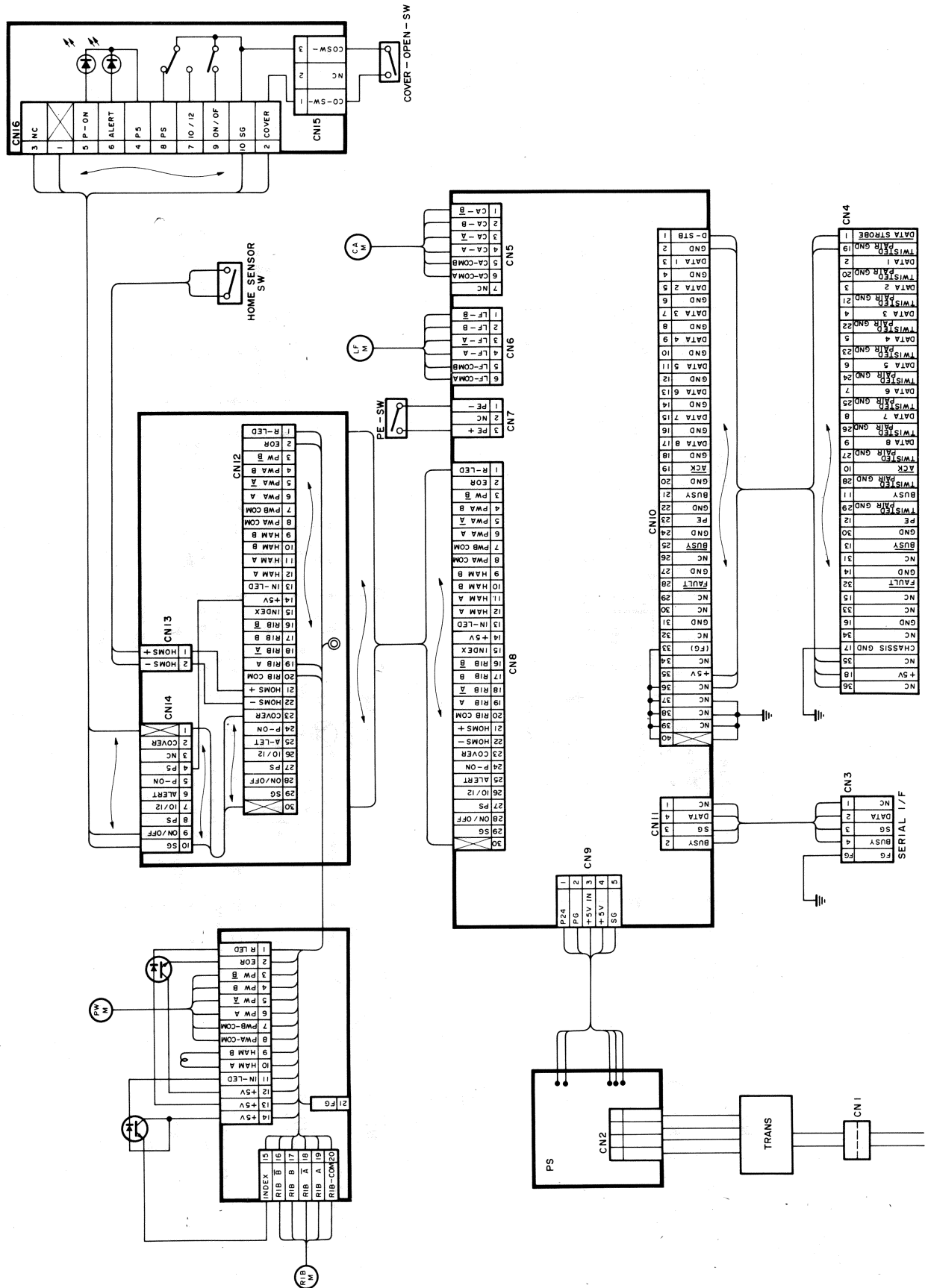

IMPORTANT INFORMATION

This equipment generates and uses radio frequency energy. If it is not installed and used properly, that is, in strict accordance with the manufacturer's instructions, it may cause interference to radio and television reception. It has been type tested and found to comply with the limits for a Class B computing device in accordance with the specifications in Subpart J of Part 15 of FCC Rules, which are designed to provide reasonable protection against such interference in a residential installation. However, there is no guarantee that interference will not occur in a particular installation. If this equipment does cause interference to radio or television reception, which can be determined by turning the equipment off and on, the user is encouraged to try to correct the interference by one or more of the following measures:

- reorient the receiving antenna
- relocate the computer with respect to the receiver
- move the computer away from the receiver
- plug the computer into a different outlet so that computer and receiver are on different branch circuits.

If necessary, the user should consult the dealer or an experienced radio/television technical for additional suggestions. The user may find the following booklet prepared by the Federal Communications Commission helpful: **How to Identify and Resolve Radio-TV Interference Problems**. This booklet is available from the United States Government Printing Office, Washington, DC 20402, Stock No. 004-000-00345-4.

Warning: This equipment has been certified to comply with the limits for a Class B computing device, pursuant to Subpart J of Part 15 of FCC Rules. Only peripherals (computer input/output devices, terminals, printers, etc.) that are certified to comply with the Class B limits may be attached to this computer. Operation with non-certified peripherals is likely to result in interference to radio and TV reception.

RADIO SHACK, A DIVISION OF TANDY CORPORATION

**U.S.A.: FORT WORTH, TEXAS 76102
CANADA: BARRIE, ONTARIO L4M 4W5**

TANDY CORPORATION

AUSTRALIA

91 KURRAJONG ROAD
MOUNT DRUITT, N.S.W. 2770

BELGIUM

PARC INDUSTRIEL DE NANINNE
5140 NANINNE

U. K.

BILSTON ROAD WEDNESBURY
WEST MIDLANDS WS10 7JN