

FIG # 2

.....  
 \* SCHEMATIC DRAFTING PROCESSOR \*  
 .....

by Tony DiStefano

for the TRS-80 COLOR COMPUTER  
with 64K memory & one disk drive.

## FEATURES:

- \* Make professional looking schematic diagrams
- \* Easy to use : Friendly prompts
- \* 6 overlapping screens to make a 480 X 540 pixel worksheet
- \* Print text on screen
- \* Help files in all modes
- \* Complete dump to printer
- \* Save & load created schematics to disk
- \* Over 30 electronics symbols
- \* Up to 10 user definable symbols
- \* Logic gates
- \* Multipin chips
- \* Supports three kinds of printers, EPSON, RS, & GEMINI

INTRODUCTION

This manual describes SDB (Schematic Drafting Processor), for the Color Computer. The object of this program is to draw, save and print electronic schematics. This is done by moving a cursor around on the screen and by hitting the right keys, place pre-defined symbols on the screen. Lines can be drawn to connect the components together, and text can be used to label them. In fact, SDP has everything you need to draw a full schematic. See Fig # 1 for a printout of the schematic provided by SDP. A full schematic page of 480 by 540 pixels reside in memory at one time. That is the equivalent of PCLEAR 24. After a schematic is finished, a hard copy can be made with a graphics printer. Several pages can be used to draft a large schematic. The best way to get familiar with all the capabilities of this program is to try all the options available. If you are lost or get stuck, hit the <CLEAR> key. A short discription of the all options available in that particular mode will be displayed.

TABLE OF CONTENTS

LOADING AND RUNNING INSTRUCTIONS..... 3  
CURSOR CONTROL..... 3  
JOYSTICK VS. ARROWS..... 3  
LOAD AND SAVE..... 3  
USER DEFINABLE..... 4  
MAIN COMMAND MODE..... 4  
DRAW MODE..... 5  
ANGLE MODE..... 7  
THE <E> KEY..... 7  
THE <M> KEY..... 8  
ERASE MODE..... 8  
FIND MODE..... 9  
MARKER POSISION..... 9  
SCREEN CHANGE..... 9  
OVERLAP..... 10  
TEXT MODE..... 10  
QUIT..... 11  
PRINTER OPTION..... 11  
USER DEFINABLE SYMBOLS..... 11  
CONCLUSION..... 12

1 LOADING AND RUNNING INSTRUCTIONS

Before running SDP, turn your computer off for 15 seconds then turn it on again. This is to insure that all the pointers and modes are set right. Now type RUN "SDP" <ENTER>. You will be immediately greeted with the SDP title page. A few moments later you will be ready to start drafting your electronics ideas and make professional looking schematic diagrams. For a hard copy a graphics printer is necessary. See Section 18.

2 CURSOR CONTROL

The first prompt you will get asks for either joystick or arrows control. This will determine how you position the cursor around on the screen. The cursor is a flashing dot one pixel high and one pixel wide. In the MAIN COMMAND MODE the cursor is the focal point for all drawing routines. All electronic symbols are drawn at the cursor.

3 JOYSTICK VS. ARROWS

Hitting the <J> key to the first prompt will transfer cursor control to the joystick. A RS compatible joystick must be plugged into the right joystick port for proper operation. An auto centering joystick is preferred but not necessary. For positioning the cursor anywhere on the screen move the joystick in the direction that you want the cursor to go. Putting the joystick in the center of its travel will stop the cursor from moving any further. The further you push the joystick in a given direction the faster the cursor will move. For short accurate movement just touch the joystick in the direction you want. For fast, long displacement, push the joystick all the way to the edge of the travel. If you loose the position of the cursor press the <F> for "FIND", key. This will put the cursor in the middle of the screen.

Hitting the <A> key to the same prompt will transfer cursor control to the 4 arrow keys. Pressing any arrow key will cause the cursor to move in that direction. The cursor will move at a rate of 1 pixel per flash. If you want to move half way across the screen, it might take some time. Thank God for the SCALE FACTOR. Pressing the <2> in the MAIN COMMAND MODE key will cause the cursor to move 4 pixels per flash, pressing the <3> in the same mode key will cause the cursor to move 9 pixels per flash, the <4> key is 20 pixels per flash. Pressing the <1> key will return the cursor to one pixel per flash. Just like in the joystick mode, pressing the <F> key in this mode will cause the cursor to move to the center of the screen.

The next prompt is simple. It asks if you want to load an old schematic into memory. When running SDP for the first time you can answer <Y> and load the sample schematic provided or answer <N> and go directly to the Main Command Mode. After you have drafted a schematic of your own, you can load it to view, change, continue drafting or print. When loading schematics use the standard name, extension and drive number for disk files. If omitted SDP will default to the extension of DAT and drive 0. If you get an I/O error, or any other error for that matter, while trying to load a schematic, type GOTO 120 <ENTER>. This will bring you back to the LOAD OLD DRAWING prompt. Since is it the beginning of the program a simple RUN will be OK.

When you hit <Q> for Quit (See Section 17) you can save your current schematic by hitting <Y> to the SAVE prompt. A standard file name of 8 characters or less is necessary. An extension name and drive number is optional. The standard default values are in effect. If for some reason you get an error here, DO NOT TYPE IN "RUN"! you will lose all the work you have done. Instead type in GOTO 300 <ENTER>, you will then be asked if you want to save your schematic. You can save the schematic or continue to draw. For now just hit the <N> key and continue reading.

#### 5 USER DEFINABLE

Sometimes, in a special case, an unusual symbol is needed, a symbol that is not in SDP's library. SDP has the capability to load in 10 auxiliary symbols. Symbols that are User definable. Answer <Y> only if you have previously created such a file. See Section 19 on how to create this file. Standard file names are used.

#### 6 MAIN COMMAND MODE

After satisfying the LOAD prompt you will go directly into the MAIN COMMAND MODE. Most of your time will be spent in this mode. All the commands, with the exception of <Q> (See Section 17), will return you to this mode once the command has been completed. Most of the commands will need one or two more parameters to complete.

Parameters are one or more keystrokes long, so in some cases you will need to hit several keys before returning to the MAIN COMMAND MODE. The commands available in this mode are described in TABLE # 1. Hitting the <CLEAR> key in this mode, or any other mode, will display what mode you are presently in and the list of the available options for that mode. Every command will be discussed in detail later in this manual.

TABLE # 1

- <A> - Change the default Angle to one of 4 angles.
- <D> - Draws a symbol at the point last held by the current cursor position.
- <E> - Erases a square block of area defined by the last Marker position and the current cursor position.
- <F> - Finds the cursor and places it in the center of the screen.
- <M> - Updates the Marker position to the current cursor position.
- <Q> - Exits the MAIN COMMAND MODE and returns you to I/O control.
- <S> - Saves the current Screen and displays the new Screen you asked for.
- <T> - Allows you to type Text on the screen.
- <1> - Sets the displacement of the cursor to 1 pixel per flash.
- <2> - Sets the displacement of the cursor to 4 pixels per flash.
- <3> - Sets the displacement of the cursor to 9 pixels per flash.
- <4> - Sets the displacement of the cursor to 20 pixels per flash.
- <CLEAR> - Displays a mini HELP FILE for this mode.

#### 7 DRAW MODE

This is the heart of the program. All of the Electronic component symbols are drawn on the screen in this mode. When the <D> key is pressed in the MAIN COMMAND MODE you enter into this mode. The next key you hit will draw the component it represents. The only exception to that is the <E>, <M> and <CLEAR> keys. These keys will be explained later. Keys not representing components will draw nothing on the screen and return control to the MAIN COMMAND MODE. All components are drawn starting at the current cursor position. Most components, like a Resistor, a Fuse, a Capacitor etc... are drawn from left to right. Some components are drawn downwards. It is important to know which direction a given component goes. Since SDP does not check where the cursor is before drawing a component, you must be sure that the component does not go beyond the boundaries of the current screen. If that happens, the component will not be drawn properly. In that case erase the component and draw it on the next screen. It may be desirable to draw a component in a different angle than it is normally drawn. See the description on Angles in Section 8. Table # 2 describes each available key in the DRAW MODE. Fig # 2 is a printout (On the MX-80) of all the component symbols. Under each symbol is the Key (Or Keys) it takes to draw it. The arrow that points towards the symbol indicates the position of the Cursor before the symbol is

drawn. The arrow that points away from the symbol indicates where the cursor will be after the symbol is drawn. The descriptions and diagrams assume the Angle equals one.

\*\*\*\*\*  
 TABLE # 2

- <A> - Antenna. Draws upwards.
- <B> - Battery. Drawn downwards and to both sides of the cursor.
- <C> - Capacitor. Drawn to the right side of the cursor.
- <D> - Diode. Drawn to the right side of the cursor. Positive side to the right.
- <E> - Logic Gates. See Section 9.
- <F> - Fuse. Drawn to the right side of the cursor.
- <G> - Ground. Drawn downwards and to both sides of the cursor.
- <H> - SCR. Draws downwards. The gate to the left of the cursor.
- <I> - Inductor. Drawn downwards from the cursor.
- <J> - Junction. Makes a connection in the center.
- <K> - L.E.D. Draws from left to right.
- <L> - Line. Draws a line from the last component drawn or from the current Marker position to the current cursor position. The Angle does not effect the Line drawing.
- <M> - Multipin Chips. See Section 10.
- <N> - Push Button. Momentary switch. Draws from left to right.
- <O> - Op amp. Drawn from the right and downwards of the cursor.
- <P> - Point. Draws the Appow Point of a Transistor. Defaults to an NPN with emitter downwards.
- <Q> - Square. Draws a square using the current Marker position and the current cursor position.
- <R> - Resistor. Draws from left to right.
- <S> - Switch. Single pole double throw. Draws from left to right, switch arm up.
- <T> - Transistor. Draws from left to right. At the base.
- <U> - Crystal. Draws from left to right.
- <V> - Variable Resistor. Potentiometer. Draws from left to right and arm points upwards.
- <W> - Ac plug. Pins face left.
- <X> - Transformer. Draws left to right and downwards.
- <Y> - Circle. Draws from the left to right.
- <Z> - Zener Diode. Draws from left to right.
- <. > - FET. Draws from left to right and starts at the Gate
- << > - Mic. Draws from the right to left.
- <> > - Speaker. Draws left to right.
- <@ > - Dot d line. 4 dots on & 4 dots off. In the current Ang . Hit <D> & <@> for as long as you need.
- <, > - Connector. Draws from left to right. Two wire with cen r control.
- <+ > - Small circle with a plus sign in the center. Draws upwards.

- <- > - Small circle with a minus sign in the center. Draws downwards.
- </ > - Photo diode. Same as a transistor.
- <: > - Draws a small line with an arrow at the end. For trimmers. Upwards and to the right.
- <? > - Light bulb. Draws from right to left.
- <0-9 > - User defined symbols. See Section 19
- <CLEAR > - Displays a mini HELP FILE for this mode.

\*\*\*\*\*  
 8 ANGLE MODE

Hitting the <A> key, in the MAIN COMMAND MODE, will change the Angle at which the component is drawn. The default Angle is <1>. This means that the component will be drawn in its original, left to right to down, angle. Angle <2> is a 90 degrees clockwise shift to the norm. IE... a resistor, in the default Angle <1>, will be drawn left to right with respect to the current cursor position. In Angle <2>, the resistor will be drawn straight downwards with respect to the current cursor position. This is true for all of the components. There are two more Angle position available, <3> and <4>. Angle <3> will cause a component to be drawn 180 degrees from the norm. In otherwords from right to left with respect to the current cursor position. Angle <4> will be 270 degrees from the norm or drawn upwards with respect to the current cursor position. See the insert in Fig # 2. When you change the Angle, it will stay in that angle until you change it again. You must keep track of what Angle you are in at all times in order to draw the next component in the right direction. Hitting the <CLEAR> key in the MAIN COMMAND MODE will display the present Angle.

Once the component is drawn, the Marker (See Section 13) position and the current cursor position will be moved, to the most likely position, to continue drawing the next component or line. This minimizes the amount of keystrokes needed to complete the schematic. ie... hitting the <D> and <R> key repeatedly will draw a string of resistors all in a row across the screen. There is no need to move the Marker or the Cursor. Lines can be drawn as you would with a pencil, from one line to another. Just move the cursor to the next position where you want the line to be drawn and hit <D> and <L>.

9 The <E> key.

Hitting the <E> key, in the Draw Mode, will go to the Logic Gate Mode. It will not immediately return to the Main Command Mode, but wait for another keystroke. This keystroke will then cause SDP to draw one of eight Logic Gates. Table # 3 is a list of gates you can draw and what keystroke it takes to draw it...

TABLE # 3

- <1> - Buffer gate.  
 <2> - 2 Input and gate.  
 <3> - 2 Input or gate.  
 <4> - 3 Input and gate.  
 <5> - 3 Input or gate.  
 <6> - 4 Input and gate.  
 <7> - 4 Input or gate.  
 <8> - 2 Input exclusive or gate.  
 <N> - Makes any of the above into a Nor or Nand. Must be the next key hit immediately after drawing a gate.  
 <CLEAR>- Displays a mini HELP FILE for this mode.

## 10 The &lt;M&gt; key.

Hitting the <M> key in the DRAW Mode will invoke the Multipin Chip Mode. The idea behind the Multipin Mode is to draw an IC pinout. Since there are ICs with the amount of pins between 8 and 68, it is easier to make one chip with variable pin numbers. When in this mode, the <T>, for Top, key will draw the top 8 pins of an IC. Then every time you hit the <SPACE> key, two more pins will be added to the bottom of the IC. After the right amount of pins is reached, hit the <B>, for Bottom, key and this will close the bottom of the chip. This does not add any pins but just closes the bottom of the IC. If the IC has too many pins to fit on one screen, hit the <SPACE> key for only as far as the pins will fit, on one screen. Then hit any key other than the <T>, <B>, <SPACE> keys. This will return you the MAIN COMMAND MODE. Change to the right SCREEN (See Section 14) and locate the pins of the IC in Question. Position the cursor to the tip of the last pin. Then hit, the <D> to go into the DRAW MODE, the <M> key to get into the Multipin Mode and the <SPACE> key to continue to add pins to the IC. Hit the <B> key to close the bottom and then continue to draw. Experiment with the Angle option to get the feel of where to place the cursor and the position of the IC.

## 11 ERASE MODE

Hitting the <E> key in the MAIN COMMAND MODE will invoke the erase procedure. The area to be erased is defined by the last MARKER position (See Section 12) and the current cursor position. These two points form the two diametrically opposite corners to form an invisible square. Everything within the boundaries of the square will be erased, including the Marker position point. The Marker position itself is still there. If the current Marker position and the current cursor position are in a vertical line then only the points on that line will be erased. Likewise on a horizontal line.

The ERASE MODE requires only one keystroke, the <E> key. Control is then transferred back to the MAIN COMMAND MODE. The only prerequisite to the ERASE MODE is that the Marker position and the cursor position be set to the right positions.

## 12 FIND MODE

Hitting the <F>, for FIND MODE, key in the MAIN COMMAND MODE will simply put the cursor to the middle of the current screen. This is used when the location of the cursor seems to be temporarily lost. In a complex draft one small flashing dot can get lost. In that case just hit the <F> key in the MAIN COMMAND MODE and the cursor will jump to the center of the present screen.

## 13 MARKER POSITION

Hitting the <M>, for MARKER POSITION, key in the MAIN COMMAND MODE will update the current Marker position. The Marker position is a point on the screen used, when two coordinate parameters are needed. For example a line needs a Start point and an End point. In a line the Start point is the current cursor position and the End point is the current Marker position. When you hit the <M> key, a dot is left on the screen to show its position. The only way to erase this point, and nothing else is to put the cursor right on it and hit the <E> for Erase in the MAIN COMMAND MODE. The Marker position is also updated every time you draw a symbol. It is updated to the most likely position on the symbol so to continue drawing with the least amount of keystrokes. i.e... a resistor has two leads and is drawn from one end to the other. The Marker position will be moved from the front of the resistor to the end, therefore, a new component can be drawn without having to update the Marker position. Updating is done automatically by SDP.

## 14 SCREEN CHANGE

The <S> for SCREEN Change, in the MAIN COMMAND MODE, will do just that: Change one of the 6 screens presently being viewed. What does this mean? An explanation of the 6 Screens is now necessary. The main object of this program is to produce a professional looking electronic schematic diagram on paper. The resolution of the SDP drafting board is 480 pixels wide by 540 pixels deep. The resolution of an 8 1/2 by 11 inch page of the EPSON or the RADIO SHACK graphic printers is 480 pixels wide by 792 pixels long. That means that the SDP draft will fit fine on these printers. The resolution of the highest graphics mode on the Color Computer is 256 pixels wide by 192 pixels long. It is not possible to view all of the drafting area at once on the computer, therefore a window (or SCREEN) is used to peek at part of the overall draft. This window (SCREEN) can be moved to view 6 different parts of the draft. The SCREENS are numbered 1 to 6. Table # 4 describes the location of each of these SCREENS.

TABLE # 4

<1> - SCREEN # 1 is in the topmost lefthand corner.  
 <2> - SCREEN # 2 is in the topmost righthand corner.  
 <3> - SCREEN # 3 is in the center lefthand corner.  
 <4> - SCREEN # 4 is in the center righthand corner.  
 <5> - SCREEN # 5 is in the bottom lefthand corner.  
 <6> - SCREEN # 6 is in the bottom righthand corner.  
 <CLEAR>- Displays a mini HELP FILE for this mode.

## 15 Overlap

Since the width of the computer screen is not exactly double the width of the draft, there will be an overlap between any two Screens that are besides each other. Screen <1> overlaps Screen <2>, Screen <3> overlaps Screen <4>, and Screen <5> overlaps Screen <6>. The same is true for the length. The Screens overlap lengthwise as well. Screens <1> & <3> and <3> & <5> overlap as well as Screens <2> & <4> and <4> & <6>. The vertical overlap between screens is 18 pixels and the horizontal overlap is 32 pixels. That is sufficient overlap to be able to cross over to another Screen and still recognize the component or line on the other screen. The best way to familiarize yourself with the procedure is to experiment with the <S> option.

## 16 TEXT MODE

Hitting the <T>, for TEXT MODE, in the MAIN COMMAND MODE, is used to print text on the screen. This is used for parts ID and values and footnotes. It is not intended to be used as a word processor, so don't expect all of the fancy editing features found in one. The only editing feature available, is the Backspace. It does just that, like the Backspace in Basic. The other control character is a CR. A CR is a carriage return invoked by the <ENTER> key. When hit, it will force a return and a line feed, but will only return as far as necessary to be directly under the first character typed when the TEXT MODE was invoked. To go further backwards without having to exit the TEXT MODE and reposition the cursor, just hit the Backspace as many times as needed. Remember though, the backspace will erase anything in its path.

Table # 5 shows a list of the character set available to the user. All the characters are set in a 4 by 6 pixel square. This is done so that the characters could fit anywhere, such as, in between pins of an IC and inside an OP amp. To get out of the TEXT MODE, just hit the <UP ARROW>, and control will be transferred back to the MAIN CONTROL MODE.

TABLE # 5

1 - All letters from A to Z  
 2 - All numbers from 0 to 9  
 3 - Special characters + - . / @  
 4 - The 'OHMS' symbol = <?>  
 5 - The 'AC' symbol = <;>  
 6 - Space bar  
 <CLEAR>- Displays a mini HELP FILE for this mode.

## 17 QUIT

When it is time to QUIT, hitting the <Q> key in the MAIN COMMAND MODE will exit the MAIN COMMAND MODE. The next prompt after that will be the option to save the present draft from memory to disk. When that is over, the next prompt is the option to print (See Section 13.1). If the <N> key is pressed, then the final prompt comes up. This asks to return to the MAIN COMMAND MODE. Hitting the <Y> key will transfer control back to the MAIN COMMAND MODE, preserving the old drawing. <N> is a return to Basic.

## 18 PRINTER OPTION

In order to use this option, an EPSON, GEMINI or RS printer must be on line. The EPSON printer must have GRAFTRAX or GRAFTRAX+ installed. The baud rate must be set correctly, though not necessarily 600 baud. The printer MUST BE SET TO 8 BITS to work. When the Printer option is invoked, a prompt will ask if you have an EPSON, GEMINI or a RS printer, answer accordingly. At 600 baud, the EPSON will take approximately 8.8 minutes to print. Some RS printer models will take up to 45 minutes to print. This is normal, remember, over a quarter of a million bits are being transferred. Higher baud rates will increase speed considerably. Adjust the printer paper about 1-1/2 inches below the top margin and in the center. It is necessary to use 8-1/2 inch wide paper with friction feed printers, or 9-1/2 inch paper with tractor feed printers. The print out of the schematic will fill almost 10 inches vertically.

## 19 USER DEFINABLE SYMBOLS

It may happen that your drawing requires a symbol not described in this program. In that case it is possible to design your own symbols and load them into SDP. Up to 10 symbols are definable. When loaded into SDP, the symbols will be labeled <0> to <9>. This means that in the DRAW MODE these symbols will appear at the Cursor position when one of these keys are hit. It is up to the User to create and edit these symbols. Table # 6 shows a simple Basic program on how to create a SYMBOL file. Try them out to get a feel of how it works. Change the variables and see what effect it has on the drawing. The only way to get a

feel of how the whole thing operates is to experiment.

The first variable in each Write #1 line is the actual drawing. It must follow the rules set by Extended Basic on the DRAW command. See Page 53 of the Going Ahead With Extended Basic manual. All of the motion and option commands are allowable. Do not use the modes of C, A, and S. Using these parameters will produce unpredictable results. Looking at the example in Table # 6, line 30 describes a simple box. Since it first in the list, it will be drawn when the key <0> is hit in the DRAW MODE. The second variable in each Print line is the horizontal offset of the Cursor after the symbol is drawn. When SDP is finished drawing the symbol, it will automatically update the Cursor's horizontal position using this value. The third variable is the same as the second but controls the vertical position. The second and third values in line 30 are both 10. That means that when SDP draws the square it will update the Cursor to the bottom right hand corner of the square (If the Angle is 0). Drawing can now continue from there.

TABLE # 6

```

0 REM SDP SYMBOLS
10 OPEN "0",#1,"SYMBOLS/SDP"
20 WRITE #1, "R10D10L10U10",10,10
30 WRITE #1, "E15F15L20",20,0
40 WRITE #1, "R4U2R3D4R3U4R3D4R3U2R4",20,0
50 WRITE #1, "O4U8R10D4L4U4",0,0
60 WRITE #1, "E10D20H10",10,0
70 WRITE #1, "R4D4D8U4R4",8,0
80 WRITE #1, "D5L5G4E4R5G4E4R5G4E4",0,0
90 WRITE #1, "R5U5D10BM+3,0U10BM+3,0D10U5R5",16,0
100 WRITE #1, "D5R1U5R1D5R1U5R1D5R1U5R1",0,0
110 WRITE #1, "D10U5R5U10D5BM+5,0U5D10",0,0
120 CLOSE #1

```

It is not necessary to define all 10 of the symbols. If only 5 are needed then only describe 5. The rest of the symbols will not do anything when the key for that symbol is hit.

## 20 CONCLUSION

A lot of time and effort has gone into making SDP a error free program. If by any chance you find an error or the program crashes for any reason, we would like to hear about it. Try to remember what made it crash and describe exactly how you did it. If we can reproduce the problem then we will fix it and send you a update for a reasonable shipping fee. If you have a problem understanding the workings of this program, drop us a line and a short blurb of what you don't understand and we'll try to clear up the situation.

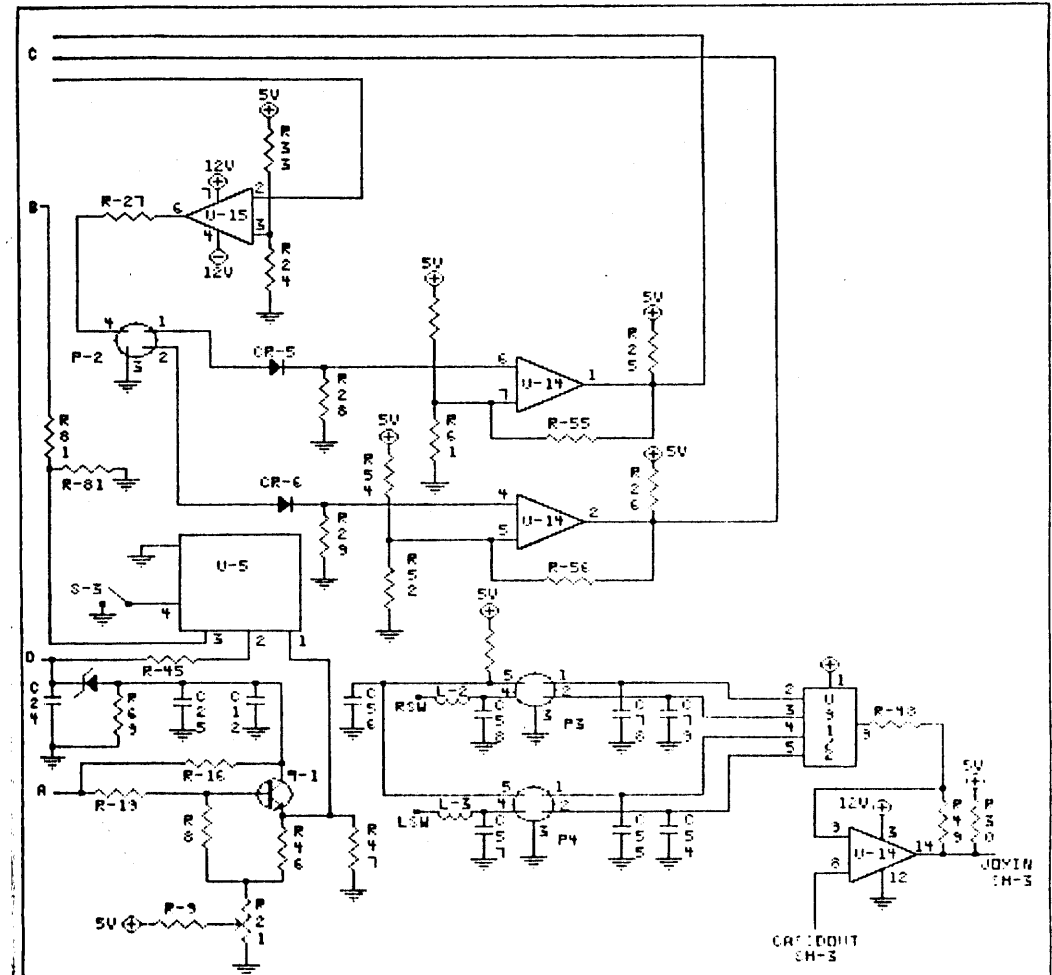

FIG # 1