

TANDY COMPUTER

CAT. NO. 68-2016

# Whiz Kids™

STARRING



ALEC AND SHANNA

ADDED  
BONUS!

"ARCHIE AND THE HISTORY  
OF ELECTRONICS..."  
INCLUDING SHUTTLE ENDEAVOUR'S  
RESCUE OF A RUNAWAY SATELLITE!

THE  
COMMUNITY  
ACTION  
PROGRAM

COMPLIMENTS OF  
**Radio Shack®**  
A DIVISION OF TANDY CORPORATION



INTRODUCING

# Sensation!

*Anything else is just a PC.*



What makes Sensation different from other PCs you may have seen? The *experience* it gives you—a blend of sights, sounds and action that makes other PCs seem primitive by comparison.

Sensation comes with incredible software on CD-ROM compact discs, including an encyclopedia, world almanac, atlas and more. And it takes computer games to new dimensions with unbelievable graphics, lifelike animation and digital stereo sound. Sensation's rich one-on-one interactive environment will dramatically change the way you relate to computers!

**TANDY**

*Experience the Tandy® Sensation today!*



# Whizkids

IN

## "THE COMMUNITY ACTION PROGRAM"

SEE, THIS USED TO BE SUCH A BEAUTIFUL PART OF TOWN, UNTIL GRAFFITI STARTED SHOWING UP ON EVERYTHING!

I KNOW, SHANNA! I GUESS PEOPLE DON'T REALIZE GRAFFITI IS A TYPE OF POLLUTION!



SCRIPT: MIKE FELLOWSKI

PENCILING: STAN GOLOBERG

INKING: MIKE ESPOSITO

LETTERING: BILL YOSHIDA

COLORING/PRODUCTION: BARRY GROSSMAN

EDITOR: VICTOR GONELICK

SOME PEOPLE CLAIM GRAFFITI IS AN ART FORM, BUT I THINK IT'S AN UGLY EYESORE!

I AGREE! THERE ARE BETTER WAYS FOR PEOPLE TO EXPRESS THEIR ARTISTIC TALENTS THAN BY CREATING GRAFFITI!



COME ON, SHANNA! LET'S DROP OFF ZEKE BRAXTON'S BOOKS SO WE CAN HEAD FOR HOME!

ZEKE SURE HAS BEEN MISSING A LOT OF SCHOOL LATELY, ALEX! I HOPE HE'S OKAY!







AREN'T YOU MRS. RILEY? DIDN'T YOU USED TO TEACH ART AT OUR SCHOOL?

YES! I RECOGNIZE YOU ALSO! YOU'RE ALEC AND SHANNA, TWO OF THE NICEST STUDENTS I EVER HAD!



ARE YOU SURE YOU'RE OKAY, MRS. RILEY? MAYBE WE'D BETTER WALK YOU HOME SO YOU GET THERE SAFELY!

THANK YOU, ALEC! I'D APPRECIATE THAT! I DON'T LIVE FAR!



THIS NEIGHBORHOOD HAS CHANGED A LOT SINCE I MOVED HERE YEARS AGO! NEVERTHELESS, I COULDN'T BRING MYSELF TO MOVE AFTER MY HUSBAND PASSED AWAY!



THIS PLACE IS MY HOME! I LOVE IT, EVEN THOUGH SOMETIMES IT'S A BIT LONELY FOR A RETIRED PERSON!

BUT YOU MUST HAVE LOTS OF FRIENDS, MRS. RILEY!



I DO! I'M ON THE EXECUTIVE BOARD OF THE SENIORS' CENTER AND I MEET LOTS OF PEOPLE THAT WAY!

IT LOOKS LIKE A REALLY NICE PLACE!









MINUTES LATER...

LOOK, ALEC! ISN'T THAT ZEKE BRAXTON WITH THOSE BOYS?

YOU'RE RIGHT, SHANNA! I WONDER WHAT HE'S DOING HERE!



HI, ZEKE! YOU'RE JUST THE PERSON WE WERE LOOKING FOR, BUT WE THOUGHT YOU WERE SICK!

I WAS SICK-- SICK OF SCHOOL!

HA!  
HA!  
HA!



MRS. WILSON ASKED US TO BRING YOU YOUR HOMEWORK!

THANKS, BUT I WON'T HAVE TIME TO DO IT. MY FRIENDS HAVE AN ART PROJECT THEY NEED HELP WITH!



ZEKE SURE ACTED STRANGE! I DIDN'T EVEN GET A CHANCE TO TELL HIM WHAT MRS. RILEY THOUGHT OF HIS DRAWINGS!

YOU CAN TELL HIM IN SCHOOL TOMORROW... IF HE SHOWS UP!



YO! ZEKE! LET'S GO, DUDE!

SO LONG, ALEC AND SHANNA! SEE YOU AROUND!



EXCUSE ME, MISS! I'M NEW IN TOWN! COULD YOU DIRECT ME TO THE SENIOR CITIZENS' CENTER?

YES, SIR! IT'S RIGHT DOWN THIS STREET! YOU CAN'T MISS IT!





LATER AT HOME...

ALEC! HOW CAN I MAKE A HOME VIDEO OF YOU HARD AT WORK AT YOUR COMPUTER IF YOU JUST SIT THERE?

SORRY, SHANNA, I WAS THINKING ABOUT MRS. RILEY AND HER FRIENDS!



WHAT DO YOU MEAN?

I WAS THINKING OUR CLASS AT SCHOOL COULD GET INVOLVED WITH ASSISTING SENIOR CITIZENS AS PART OF OUR COMMUNITY SERVICE REQUIREMENT!



I THINK THAT'S A TERRIFIC IDEA! MRS. RILEY MENTIONED PEOPLE WHO COULD USE HELP IN A VARIETY OF WAYS!

MAYBE WE COULD EVEN FIND TIME TO HELP IMPROVE CONDITIONS IN MRS. RILEY'S NEIGHBORHOOD!



WE COULD START BY GETTING RID OF THAT UGLY NEIGHBORHOOD GRAFFITI!

RIGHT, SHANNA! BUT FIRST WE HAVE TO CONVINCE MRS. WILSON TO LET OUR CLASS TAKE ON THIS PROJECT!



THE NEXT DAY AT SCHOOL.

I DON'T NEED CONVINCING, ALEC! I THINK ASSISTING SENIOR CITIZENS WOULD BE AN OUTSTANDING COMMUNITY SERVICE PROJECT!







AFTER SCHOOL...

YOU'LL LIKE MRS. RILEY, ZEKE! SHE USED TO TEACH ART! SHE SAW SOME OF YOUR DRAWINGS AND REALLY LIKED THEM!

WHO CARES? I'M INTO A NEW FORM OF ART NOW!



IS THIS THE KIND OF ART YOU'RE INTO NOW, ZEKE? WE SAW YOUR FRIENDS WITH THOSE CANS OF SPRAY PAINT!

DON'T CALL GRAFFITI ART, SHANNA, IT'S ONE OF THE WORST KINDS OF POLLUTION!



NO WAY, ALEC! GRAFFITI IS ART FOR THE MASSES! IT'S THE WAY THE NEIGHBORHOOD ARTISTS EXPRESS THEIR FEELINGS AND DEMONSTRATE THEIR TALENT!



I'LL HAVE YOU KNOW THOSE DRAWINGS WERE MADE BY A FAMOUS GRAFFITI CREW, AND PRETTY SOON THEIR WORK MAY BE SIGNED T.C.B.Z!

NO MATTER WHAT YOU SAY, ZEKE, THE TRUTH IS... GRAFFITI IS UGLY!



LET'S FORGET ABOUT GRAFFITI NOW THAT WE'RE AT MRS. RILEY'S HOUSE!

HI, ALEC AND SHANNA! I SAW YOU COMING! I WAS WAITING FOR YOU!



HI, MRS. RILEY! THIS IS ZEKE BRAXTON, THE PERSON WHO DID THOSE DRAWINGS!

I'M PLEASSED TO MEET YOU, ZEKE! COME IN! A FELLOW ARTIST IS ALWAYS WELCOME IN MY HOUSE!







DAYS LATER AT THE SENIORS' CENTER...

AFTER MUCH DISCUSSION, IT'S AGREED THAT THE PROGRAM WILL BE A ONE-TO-ONE BUDDY SYSTEM SO FRIENDSHIPS CAN BE ESTABLISHED!

SPECIAL MEETING TODAY!



ARE THERE ANY OTHER COMMENTS? MR. DOBBS!

I THINK ALEC AND SHANNA'S PROPOSAL IS TERRIFIC, BUT I HAVE A SUGGESTION!

I SUGGEST WE SENIORS SWAP OUR TALENTS, EXPERIENCE AND KNOWLEDGE IN EXCHANGE FOR THESE SERVICES!



I'M A RETIRED ACCOUNTANT! I'D BE GLAD TO TUTOR A STUDENT IN MATH IN EXCHANGE FOR OCCASIONAL HOUSEHOLD CHORES!

HEY! I LIKE DOBBSY'S SUGGESTION!



I'M A MUSICIAN! I'D TRADE MUSIC LESSONS FOR GROCERY SHOPPING!

I CAN TEACH EMBROIDERY!



I'VE ALREADY MADE PLANS TO GIVE ART LESSONS! I GUESS THIS HELP PROGRAM HAS TURNED INTO A REAL TWO-WAY STREET!



I'M SURE THERE'S SOMETHING WE ALL CAN DO TO HELP EACH OTHER! OUR SHUT-INS CAN ASSIST LATCHKEY KIDS BY CALLING THEM AND DOING PHONE CHECKS!



IT LOOKS LIKE YOUR COMMUNITY ACTION PROGRAM IS OFF TO A GREAT START, ALEC AND SHANNA!

CLAP! CLAP! CLAP!  
CLAP! CLAP! CLAP!



MY ONLY CONCERN IS HOW WILL YOU KEEP TRACK OF WHO IS GOING TO DO WHAT FOR WHOM, ALEC?

DON'T WORRY, MRS. RILEY! THANKS TO MY TANDY HOME COMPUTER THAT'LL BE A CINCH!





LATER AT THE HOME OF THE WHIZ KIDS...

GOOD WORK, ALEC, YOU'VE FINALLY MANAGED TO MATCH UP ALL OUR VOLUNTEERS AND SENIORS!

OUR TANDY COMPUTER MADE A DIFFICULT JOB EASY, SHANNA!



NOW THAT THE COMMUNITY SERVICE SCHEDULE IS COMPLETE WE CAN ALL GET TO WORK!

I CAN'T WAIT! THIS PROJECT IS NOT ONLY GOING TO BE HELPFUL, BUT FUN, TOO!



SHORTLY AFTERWARD THE VOLUNTEER HELP EXCHANGE PROGRAM IS PUT INTO ACTION...

SENIORS' CENTER



YOUNGSTERS BEGIN TO HELP SENIORS IN MANY WAYS...



YOUTH VOLUNTEERS ASSIST THEIR NEW ELDERLY FRIENDS BY DOING EVERYTHING FROM WALKING PETS TO BUYING GROCERIES...

I GOT EVERYTHING ON YOUR LIST, MRS. MARTIN!

THANK YOU, JIMMY!



SENIOR CITIZENS, TOO, TAKE PART IN THE HELP EXCHANGE...

I NEVER KNEW DOING MATH COULD BE SO MUCH FUN!



EVERYONE BENEFITS FROM THE PROGRAM...

I STOPPED AT THE ART STORE AND GOT THE SUPPLIES YOU NEEDED, MRS. RILEY!

THANK YOU, ZEKE! I HAVE A NEW PAINTING TECHNIQUE TO SHOW YOU TODAY!



BEST OF ALL, NEW FRIENDSHIPS ARE ESTABLISHED...

IT'S NICE TO HAVE A FRIEND TO TALK TO!



VOLUNTEERS YOUNG AND OLD LEARN NOT ONLY TO HELP EACH OTHER, BUT TO HAVE FUN TOGETHER...

OH, NO! YOU'VE BEATEN ME AGAIN!



ALEC AND SHANNA'S COMMUNITY ACTION PROGRAM QUICKLY BECOMES A HUGE SUCCESS.

EVERYONE IN TOWN'S TALKING ABOUT THE PROGRAM, ALEC AND SHANNA... WHAT'S NEXT?

THIS WEEKEND WE'RE HAVING A MEETING AT THE SENIOR CENTER TO DISCUSS WAYS TO BEAUTIFY THE NEIGHBORHOOD!





ON SATURDAY AFTERNOON...

HEY, ZEKE! WHAT'S YOUR HURRY, MAN? WE HARDLY EVER SEE YOU ANYMORE!

OH! HI, GUYS! I'VE BEEN BUSY WITH A NEW COMMUNITY ACTION PROGRAM!

IN FACT, WE'RE HAVING A MEETING INSIDE THE CENTER TODAY!

WHY DON'T YOU JOIN US? WE COULD ALWAYS USE MORE VOLUNTEERS!

ARE YOU KIDDING? WE DON'T HAVE TIME FOR STUPID MEETINGS! WE HAVE WORK TO DO!

YEAH! ARTWORK, IF YOU KNOW WHAT I MEAN!

WHY DON'T YOU FORGET ABOUT THAT MEETING AND JOIN US, ZEKE? WE COULD USE YOUR HELP!

NO WAY! THANKS TO MRS. RILEY, I'M LEARNING BETTER WAYS TO EXPRESS MY ARTISTIC TALENTS!

COME ON, ALEC AND SHANNA, WE'LL BE LATE FOR THE MEETING!

ZEKE, YOU'LL BE SORRY YOU SNUBBED US! JUST WAIT AND SEE!

LATER AT THE MEETING...

WE'RE ALL AGREED THEN! WE START OUR BEAUTIFYING THE NEIGHBORHOOD CAMPAIGN NEXT WEEKEND!



THE TARGET OF OUR FIRST GROUP CLEAN-UP WILL BE THE PARK NEXT DOOR! ALL THAT HAS GOT TO GO!

CLAP!  
CLAP!



THE FOLLOWING WEEKEND THE WAR ON NEIGHBORHOOD GRAFFITI BEGINS.

PHEW! IT ISN'T EASY TO GET RID OF GRAFFITI!

GETTING RID OF IT IS HARD WORK, BUT THE END RESULT WILL BE WORTH IT!



YOU'RE RIGHT, ALEC! AT THE RATE WE'RE GOING, THIS PARK WILL LOOK LIKE NEW WHEN WE'RE FINISHED!

ONCE I THOUGHT GRAFFITI WAS A FORM OF ART! NOW I KNOW YOU WERE RIGHT, ALEC AND SHANNA! GRAFFITI SURE MAKES A NEIGHBORHOOD LOOK UGLY!





MANY HOURS LATER...  
I WASN'T SURE WE COULD DO IT,  
BUT WE DID! THE PARK IS FINALLY  
GRAFFITI FREE!

IT LOOKS  
WONDERFUL!

LOOK, GUYS! IT'S ZEKE, THE  
GRAFFITI WIZARD! HE MAKES OUR  
ARTWORK VANISH WITH A SCRUB  
OF HIS MAGIC BRUSH!

HA! HA!

I BET YOU'D LIKE TO DESTROY  
THAT, TOO, MUH? WELL IT'S TOO  
BAD THAT WALL IS TOO BIG  
TO SCRUB CLEAN!

I'VE BEEN GIVING THAT WALL A LOT OF  
THOUGHT! WE CAN'T SCRUB IT  
BUT WE COULD PAINT A NICE MURAL  
OVER THAT UGLY GRAFFITI!

A-A  
MURAL?

WHAT?

A MURAL IS A GREAT IDEA!  
ALL WE'D NEED TO DO IT  
ARE PERMISSION  
AND SUPPLIES!

AND DON'T  
FORGET  
ARTISTS!

HUMPH!

DAYS  
LATER...

WE HAVE PERMISSION TO PAINT  
A MURAL AND THE ARTISTS TO DO THE  
WORK! NOW WE  
NEED SUPPLIES!

THE SUPPLIES WE'LL  
NEED TO DO A MURAL  
THIS SIZE WILL COST  
A LOT OF MONEY!



IF THERE WAS  
ONLY A WAY WE  
COULD RAISE  
ENOUGH MONEY  
TO BUY SUPPLIES!

I HAVE AN IDEA!  
WHY DON'T WE PUT  
ON A TALENT SHOW  
AT THE CENTER?

WHAT A WONDERFUL SUGGESTION! WE  
HAVE LOTS OF TALENTED YOUNGSTERS  
AND SENIORS  
WHO WOULD BE  
HAPPY TO PERFORM!

WE COULD CHARGE  
ADMISSION! I'M SURE  
PLENTY OF PEOPLE  
WOULD COME TO  
THE SHOW!

AND I'LL USE MY TANDY  
CAMCORDER TO RECORD THE  
ENTIRE PERFORMANCE! WE  
CAN MAKE COPIES OF THE TAPE  
AVAILABLE TO SHUT-INS!

WELL, FOLKS! IT SOUNDS TO ME LIKE  
IT'S SHOW TIME! LET'S GET BUSY  
MAKING THE ARRANGEMENTS!



ON THE NIGHT OF THE SHOW

show  
★ ★ ★  
TONIGHT  
★ ★ ★

THE SHOW IS GREAT! THE CROWD LOVES IT!

AND THE CENTER IS PACKED— WITH PEOPLE!

I HAVE GOOD NEWS, I JUST COUNTED THE MONEY WE MADE ON THE SHOW. WE HAVE MORE THAN ENOUGH TO PURCHASE ALL THE ART SUPPLIES WE'LL NEED!

OFFICE

FANTASTIC!

WELL, ZEKE, IT LOOKS LIKE YOU'LL FINALLY GET TO PAINT THAT MURAL YOU AND MRS. RILEY DESIGNED TOGETHER!

IT'S A DREAM COME TRUE! THANKS FOR LETTING US USE YOUR COMPUTER TO WORK OUT THE MURAL'S COMPOSITION ALEC! I CAN'T WAIT TO GET STARTED!

WITHOUT DELAY WORK ON THE MURAL BEGINS...



HOW'S IT GOING UP THERE, ZEKE?

GOOD, ALEC! WE ALMOST HAVE ALL THE GRAFFITI COVERED! LINDA AND I WILL BE ABLE TO START OUTLINING THE COMPOSITION SOON!

I'M GLAD LINDA VOLUNTEERED TO HELP WITH THE MURAL! SHE'S ALMOST AS GOOD AN ARTIST AS ZEKE IS!



AND SHE'S A HARD WORKER, TOO!



IS THAT PAINT READY, ALEC AND SHANNA? THEY NEED IT UP ON THE SCAFFOLD!

YES, MRS. RILEY! IT'S ALL SET TO GO!



HOW LONG DO YOU THINK IT'LL TAKE TO FINISH THE MURAL, MRS. RILEY?

WITH A LITTLE LUCK WE COULD HAVE THE WHOLE THING COMPLETED BY LATE TOMORROW!



THE FOLLOWING AFTERNOON...

WELL... IT'S FINISHED AT LAST!

I THINK IT TURNED OUT VERY WELL!



VERY WELL? I THINK IT'S TERRIFIC! WHAT DO YOU THINK, ALEC AND SHANNA?



WE THINK IT'S BEAUTIFUL!



CONGRATULATIONS, ZEKE, YOU AND MRS. RILEY MAKE A WONDERFUL TEAM!

THANKS, ALEC!



WE SURE DO! I JUST HOPE WE CAN WORK TOGETHER AGAIN REAL SOON!

YOUR WISH IS MY COMMAND, ZEKE! I'VE ALREADY GOT PERMISSION TO PAINT ANOTHER MURAL IN THE NEIGHBORHOOD!



DAYS LATER...



I REALLY ENJOY VISITING THE SENIOR CENTER. EVERYONE THERE IS SO NICE!

YOU'RE RIGHT, SHANNA! GETTING INVOLVED WITH THE CENTER THROUGH COMMUNITY SERVICE HAS SURE CHANGED MY LIFE FOR THE BETTER!



ALEC! SHANNA! WAIT A MINUTE!

THERE'S LINDA! SHE LOOKS WORRIED!



LINDA, WHAT'S WRONG? YOU LOOK AWFUL!

I JUST HEARD SOME TERRIBLE NEWS FROM MY LITTLE BROTHER! HE PLAYS WITH CARLOS'S LITTLE BROTHER!



CARLOS, TEDDY AND BENNY PLAN TO RUIN OUR MURAL BY PAINTING GRAFFITI ON IT TONIGHT!



OH, NO! HOW CAN WE STOP THEM? WE CAN'T GO TO THE POLICE WITHOUT ANY PROOF!

I HAVE AN IDEA, ALEC! CAN YOU AND SHANNA MEET ME IN THE PARK TONIGHT WITH YOUR TANDY CAMCORDER?



WE SURE CAN, ZEKE! SINCE TOMORROW IS SATURDAY, IT'S NO PROBLEM!

GOOD! I THINK WE MIGHT BE ABLE TO FINALLY PUT A STOP TO THIS GRAFFITI BLIGHT!





LISTEN / THIS IS OUR NEIGHBORHOOD.  
ZEKE! AND GRAFFITI HELPS  
MAKE IT OURS!



YOU'RE RIGHT, CARLOS! THIS IS  
YOUR NEIGHBORHOOD! SO WHY  
NOT MAKE IT A BEAUTIFUL  
NEIGHBORHOOD?!



INSTEAD OF MAKING  
GRAFFITI, WHY DON'T YOU  
HELP WORK ON MURALS  
LIKE THIS ONE?



WE'RE STARTING A NEW MURAL  
IN A FEW DAYS, CARLOS - WHY  
DON'T YOU GUYS JOIN OUR  
PAINT CREW?



HOW ABOUT IT?

OKAY, ZEKE! YOU, ALEC AND  
SHANNA HAVE  
CONVINCED ME!

ME, TOO!



YOU MADE THE RIGHT CHOICE,  
CARLOS! NOW YOU'LL GET A CHANCE  
TO SHOW OFF YOUR ARTISTIC ABILITY  
IN A WAY YOU CAN REALLY  
BE PROUD OF!





THE NEXT DAY...

**KNOCK**  
**KNOCK**

I WONDER WHO THAT CAN BE?



HI, MRS. RILEY! I HAVE SOME PEOPLE I'D LIKE YOU TO MEET!

CERTAINLY, ZEKE! ANY FRIENDS OF YOURS ARE ALWAYS WELCOME HERE! COME IN!



THIS IS CARLOS, BENNY AND TEDDY! THEY'D LIKE TO WORK ON OUR NEXT MURAL WITH US!

THE MORE THE MERRIER! WE CAN ALWAYS USE TALENTED ARTISTS!



WHY DON'T WE DISCUSS THE PROJECT OVER A SNACK? NOW THAT I HAVE HELP WITH MY MARKETING, I HAVE PLENTY OF COOKIES!

GEE... THANKS, MRS. RILEY!



I'LL GIVE YOU A HAND, MRS. RILEY!

YOU KNOW, ZEKE, I THINK I'M REALLY GOING TO LIKE WORKING WITH YOU AND MRS. RILEY!

I'LL HELP, TOO!









# Whizkids

COMMUNITY ACTION



## WORD SEARCH

W	A	V	P	C	L	F	T	T	B	O	M	M	U	R	A	L	K	Z	P
M	C	J	K	D	W	O	I	L	A	P	C	V	O	V	N	T	T	S	Q
E	W	S	I	T	I	F	F	A	R	G	I	T	N	A	A	E	C	B	P
A	Z	T	I	O	E	P	W	S	K	P	U	N	A	E	L	C	L	M	L
L	T	R	R	N	O	B	C	E	N	T	L	R	N	N	B	I	F	K	E
S	R	A	E	L											G	V	D	I	H
O	E	B	P	C											E	R	H	J	D
N	T	O	A	O											X	E	V	U	L
W	N	O	I	M											Z	S	C	K	O
H	E	F	R	M											W	S	R	T	H
E	C	L	S	I											T	A	R	Y	E
E	R	S	M	T											P	P	Q	A	S
L	O	P	V	T											N	O	Y	B	U
S	I	A	N	E											M	N	H	J	O
T	N	C	L	E	S	D	I	K	Y	E	K	H	C	T	A	L	G	I	H
B	E	E	R	A	N	D	S	R	S	H	O	P	P	I	N	G	F	W	
C	S	K	F	H	L	S	T	I	S	I	V	E	M	O	H	W	A	O	D
W	J	C	G	I	M	P	E	N	I	L	T	O	H	P	L	E	H	C	E
F	R	I	E	N	D	S	H	I	P	T	C	U	V	A	X	S	B	K	L



HELP ALEC AND SHANNA FIND 20 WORDS THAT DEAL WITH COMMUNITY ACTION OR HELPING PEOPLE IN YOUR NEIGHBORHOOD IN THE PUZZLE ABOVE. SEARCH IN EVERY DIRECTION, LOOK UP, DOWN, FORWARD, BACKWARD AND DIAGONALLY. CROSS OFF THE WORDS BELOW AS YOU FIND THEM. GOOD LUCK.

COMPANY, LATCHKEY KIDS, ANTI GRAFFITI, TUTOR, HELP HOTLINE, SHOW, SHOPPING, BENEFIT, PARK, CLEAN UP, REPAIRS, HOME VISITS, SERVICE, MEALS ON WHEELS, HOUSEHOLD HELP, FRIENDSHIP, SENIOR CENTER, MURAL, COMMITTEE, ERRANDS.

# Whizkids

## WORD SCRAMBLE!

- ① IFARFGIT      ② KEMAS  
④ LRODW      ③ RUO  
⑤ LGYU

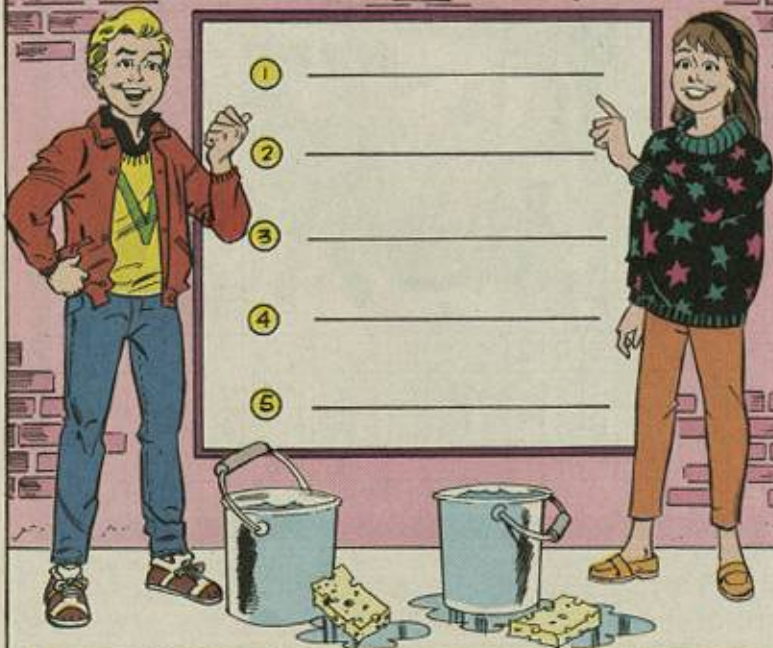

### \* DIRECTIONS

THE LETTERS OF THE WORDS ABOVE ARE ALL SCRAMBLED UP. SWITCH THE LETTERS AROUND UNTIL THE WORDS ARE SPELLED CORRECTLY. AS YOU SOLVE EACH SCRAMBLED WORD, WRITE IT ON THE CORRECT NUMBERED LINE. WHEN ALL THE WORDS ARE WRITTEN ON THE LINES YOU WILL HAVE AN IMPORTANT MESSAGE. GOOD LUCK AND HAVE FUN!



# CROSSWORD PUZZLE



### WORDS ACROSS

- ① FIXING OR MENDING THINGS THAT ARE BROKEN.
- ③ PUBLIC LAND FOR RECREATION.
- ⑤ A SPECIAL NATURAL ABILITY.
- ⑦ OPPOSITE OF YOUNG.

- ⑨ TO KNOCK SHARPLY OR A NEW KIND OF MUSIC.
- ⑪ ELECTRONIC MACHINE USED TO CALCULATE THINGS AND STORE DATA AND INFORMATION.
- ⑬ TO HOBBLE AS YOU WALK.
- ⑭ GROUP OF PEOPLE LIVING IN SAME PLACE.
- ⑯ EVERYONE INCLUDED.
- ⑰ COMPACT VIDEO CAMERA.

①		②								③			④
⑤					⑥			⑦					
												⑧	
⑨		⑩			⑪								
				⑫					⑬				
				⑭				⑮					⑯
				⑰									
⑱													

### WORDS DOWN

- ① PERSON WHOSE WORK CAREER HAS ENDED.
- ② BUDDY.
- ③ LITTER AND UNSAFE WASTE MATERIAL ARE CALLED THIS.
- ④ USE THIS TO OPEN A LOCK.
- ⑥ A SLOW JOGGING RUN.

- ⑧ ASSIST.
- ⑩ SELECT.
- ⑫ TO BUY GOODS.
- ⑮ TO SHAPE SOMETHING LIKE USING CLAY.
- ⑯ THE YELLOW PART OF AN EGG.
- ⑰ SPREAD MADE FROM FRUIT AND SUGAR.



ALEC AND SHANNA'S HINTS FOR WAYS TO HELP IN YOUR NEIGHBORHOOD!



- VISIT AN ELDERLY FRIEND ON A REGULAR BASIS.
- VOLUNTEER TIME TO A SENIOR CITIZENS' CENTER.
- HELP DELIVER MEALS ON WHEELS.
- DONATE TIME TO DO MINOR HOUSEHOLD REPAIRS.
- INVITE AN ELDERLY FRIEND TO HAVE DINNER WITH YOUR FAMILY.
- BECOME PEN PALS WITH A SENIOR CITIZEN.
- HELP PLAN SHOWS AT SENIOR CENTERS.
- ORGANIZE FRIENDS TO DO YARD WORK FOR SENIOR CITIZENS.
- BRING A PET TO VISIT.

- PHONE ELDERLY FRIENDS REGULARLY JUST TO CHAT.
- HELP ORGANIZE AND PLAN TRIPS FOR SENIORS.
- HELP SENIOR CITIZENS WITH GROCERY SHOPPING.
- HAVE AN ELDERLY FRIEND SPEND A HOLIDAY AT YOUR HOME.
- ASSIST A SENIOR CITIZEN WITH ORDINARY HOUSEHOLD CHORES LIKE LAUNDRY.
- LET AN ELDERLY FRIEND BECOME INVOLVED IN YOUR LIFE BY SHARING IDEAS, EXPERIENCES AND ADVICE.
- ASSIST SENIOR CITIZENS IN MAKING AND KEEPING APPOINTMENTS.





COLOR THIS PAGE!

"The Community Action Program" and  
"Archie & the History of Electronics..."

TANDY COMPUTER

GET AN ANSWER

Whizkids

1 TAKING

ALIC AND SHONDA

ADDED  
BONUS!

"ARCHIE AND THE HISTORY  
OF ELECTRONICS..."  
INCLUDES SHUTTLE ENDEAVOURS  
REMOVE OF A FUNNISKY SATELLITE!



THE  
COMMUNITY  
ACTION PROGRAM

COMIC BOOKS BY  
Radio Shack

Still FREE

While the supply lasts!

NOW!  
two books  
in one!

Teachers!

Write on school letterhead  
for a free packet of 50  
comic books for your class.

SEND TO: RADIO SHACK  
EDUCATION COMIC BOOK PROGRAM  
300 One Tandy Center  
Fort Worth, Texas 76102

GET YOUR FREE COPY AT

Radio Shack

A division of Tandy Corporation

at PARTICIPATING STORES and  
DEALERS IN THE U.S.A.

Here are  
the ANSWERS  
to the...

Whizkids

- WORD SEARCH
- WORD SCRAMBLE
- CROSSWORD PUZZLE



Radio Shack® PRESENTS...

# Archie AND THE HISTORY OF ELECTRONICS



SCRIPT: MIKE PELLOWSKI      ART BY: HOWARD BENDER & JON D'AGOSTINO      LETTERING: BILL YOSHIDA      COLORING: BARRY GROSSMAN      EDITOR: VICTOR GORELICK

ARCHIE AND THE HISTORY OF ELECTRONICS was produced for the Radio Shack Division of Tandy Corporation, 399 One Tandy Center, Fort Worth, TX 76102 by Archie Comics Publications, Inc., 325 Fayette Avenue, Mansfield, NJ 07933. Richard H. Goldwater, President and Co-Publisher, Michael I. Silberstein, Chairman and Co-Publisher, Radio Shack, Tandy Plus and Tandy are registered service marks and/or trademarks of Tandy Corporation, "Archie" and the individual characters names and likenesses are registered trademarks of Archie Comics Publications, Inc. Copyright © 1991 Archie Comics Publications, Inc. All rights reserved. Archie characters created by John L. Goldwater, neither Radio Shack nor Tandy Corporation, nor any of their employees makes any warranty, express or implied for the accuracy, completeness or usefulness of the information contained in this publication which is distributed free to students, teachers, schools and other persons interested in science topics. Nothing may be reprinted in whole or part without written permission from Tandy Corporation and Archie Comics Publications, Inc.





HERE'S YOUR BREAKFAST, ARCHIE! IT'S FRUIT AND GRANOLA WITH MILK!

GREAT! THAT'S WHAT I CALL FAST AND NUTRITIOUS BREAKFAST FOOD! PLUS... IT'S MY FAVORITE!



WELL, I'M IN NO HURRY, MARY! I'LL HAVE BACON, EGGS, BUTTERED TOAST WITH JAM AND...

YOU'LL HAVE A HEALTHY MEAL OF FRUIT AND GRANOLA TOO, FRED ANDREWS!

AROUND HERE WE'RE CUTTING DOWN ON FATS AND CHOLESTEROL!



HERE YOU ARE, FRED! DIG IN!

AHH... RIGHT, MARY!

CRUNCH!  
CRUNCH!



HEY! THIS GRANOLA STUFF IS PRETTY GOOD! CRUNCH, CRUNCH!

AND IT'S GOOD FOR YOU, POP! I'VE GOTTA GO! 'BYE MOM! THANKS FOR THE BREAKFAST!



HEY, ARCH! HURRY UP, OR THE CLASS WILL LEAVE WITHOUT US! CHILL OUT, JUG! I'M COMING! DON'T WORRY, THEY'LL WAIT FOR US!



THIS TRIP IS GOING TO BE REAL INTERESTING!

IT SURE IS! WE'RE GOING TO LEARN ALL ABOUT THE HISTORY OF ELECTRICITY AND ELECTRONICS!

IT LOOKS LIKE WE'RE JUST IN TIME FOR ATTENDANCE, JUG!

HUMPH! ARCHIE AND JUSHEAD ARE THE LAST TO ARRIVE... AS USUAL! OKAY! EVERYONE'S PRESENT! LET'S GET ON THE BUS!



I CAN'T WAIT TO FIND OUT ABOUT THE MANY KINDS OF POWER SOURCES!

I CAN'T WAIT TO VISIT THE COMPUTER EXHIBIT!

I CAN'T WAIT TO GET ON THE BUS AND SIT NEXT TO VERONICA!



WE'RE READY TO ROLL! LET'S GO, MR. SVENSON!



THIS RIDE WON'T TAKE LONG, CLASS! THE MUSEUM ISN'T VERY FAR!



SOON... HERE WE ARE, EVERYONE!

WOW! WHAT A BIG PLACE!

AND IT'S FILLED WITH EXHIBITS OF MAN'S GREATEST ACCOMPLISHMENTS!





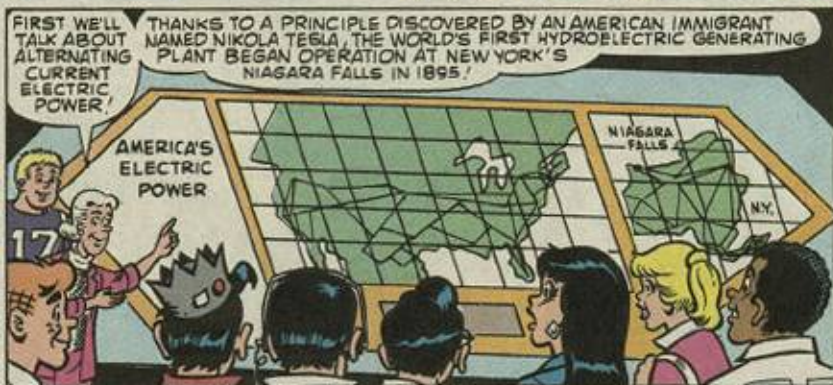

EDISON AND TESLA LATER BECAME COMPETITORS FOR THE NIAGARA FALLS PROJECT! TESLA'S DEVELOPMENT OF AN EFFICIENT DISTRIBUTION SYSTEM WITH LIMITED POWER LOSS WON!

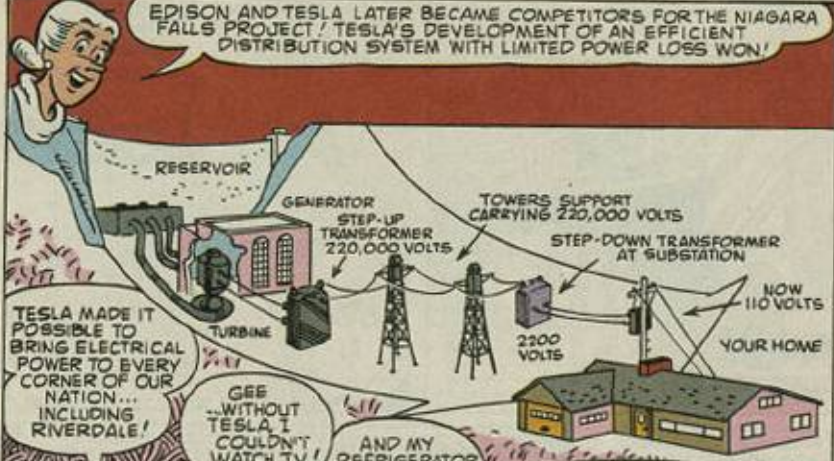

TESLA MADE IT POSSIBLE TO BRING ELECTRICAL POWER TO EVERY CORNER OF OUR NATION... INCLUDING RIVERDALE!

GEE...WITHOUT TESLA, I COULDN'T WATCH TV!

AND MY REFRIGERATOR WOULDN'T BE RUNNING!

WHAT? YOUR REFRIGERATOR IS RUNNING? THEN YOU'D BETTER GO HOME AND CATCH IT, JUG!



NIKOLA TESLA WAS A BRILLIANT MAN! HE ALSO INVENTED AN ARCH LIGHT SYSTEM AND REMOTE CONTROL RADIO DEVICES!

BUT TESLA'S MOST FAMOUS INVENTION IS THE TESLA CELL, AN ELECTRONIC TUBE INVALUABLE IN LONG DISTANCE WIRELESS COMMUNICATION!



POWER

OKAY, EVERYONE! LET'S MOVE ON TO THE NEXT EXHIBIT!





IN ADDITION TO HYDROELECTRIC GENERATING PLANTS, THE U.S. USES MANY DIFFERENT POWER SOURCES TO PRODUCE ELECTRICITY!

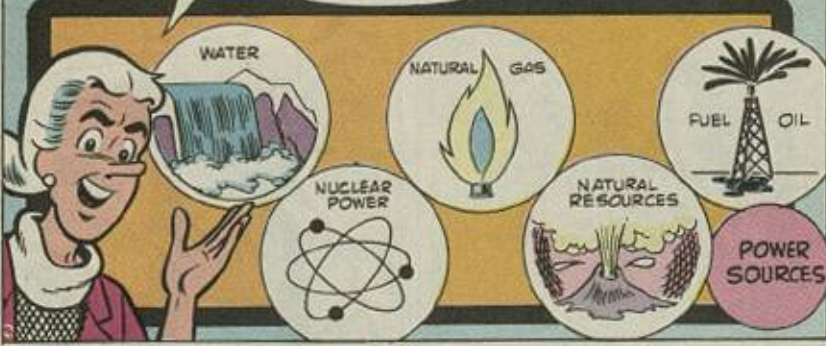

HOW CAN NATURAL RESOURCES PRODUCE ELECTRICITY, MS. GRUNDY?

GOOD QUESTION, BETTY! THE FOLLOWING EXHIBITS WILL HELP ME EXPLAIN!



IN FACT, IF WE STEP OUT ON THE BALCONY, I CAN SHOW YOU A VAST SOURCE OF POWER MANKIND IS JUST BEGINNING TO TAP!

YOU CAN?



WHERE IS THAT VAST POWER SOURCE, MS. GRUNDY?

UP THERE!

IT'S THE SUN!

THE SUN?

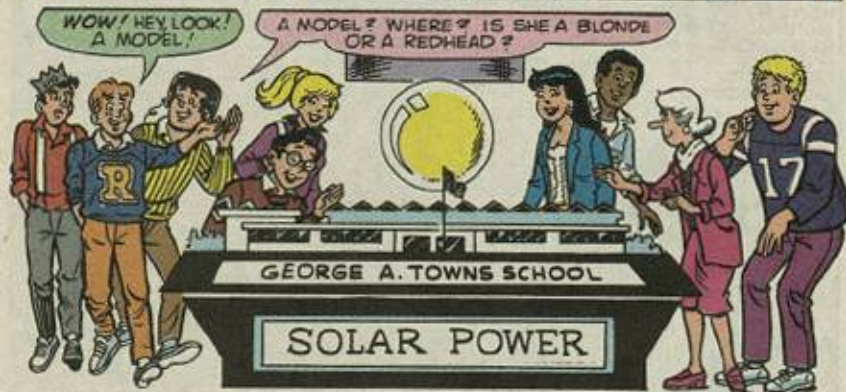
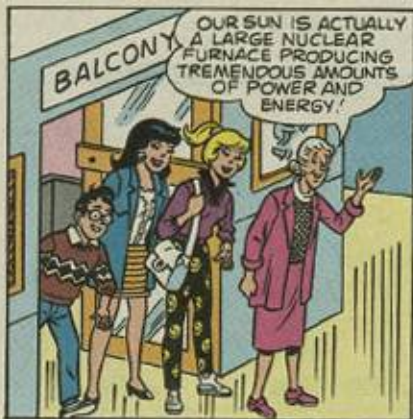



"SOLAR PANELS ARE FOUND ON THE ROOFS OF MANY HOMES AND BUILDINGS TODAY! SOLAR ENERGY PROVIDES HOT WATER AND HEAT FOR ROOMS! IT'S ALSO A GREAT WAY TO CONSERVE ENERGY!"

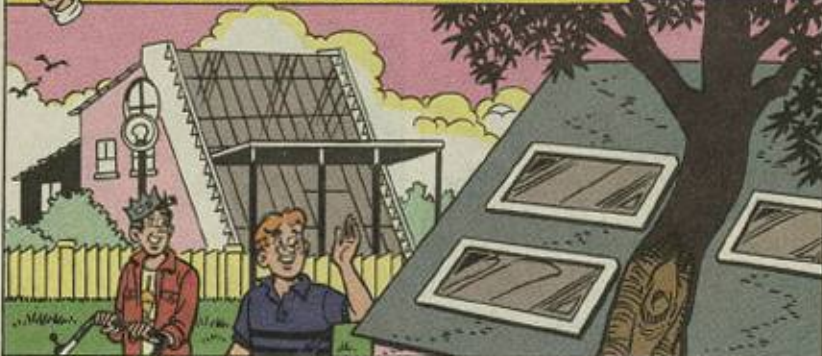

BUT HOW DOES SOLAR ENERGY BECOME ELECTRICITY, MS. GRUNDY?



LOOK AT THIS NEXT EXHIBIT AND I'LL EXPLAIN, ARCHIE! WHAT YOU SEE IS "SOLAR ONE", A SOLAR POWER TEST PLANT NEAR BARSTOW, CALIFORNIA!



SOLAR ONE HAS 2,000 MIRRORS WHICH REFLECT SOLAR HEAT TO A CENTRAL RECEIVER, MAKING STEAM TO OPERATE A TURBINE THAT PRODUCES ELECTRICITY!



THE PROJECTED GENERATING POWER OF SOLAR ONE IS TEN MILLION WATTS!

THAT'S MORE 'WHAT'S THAN REGGIE MUTTERS DURING A SCHOOL YEAR!



PHOTOVOLTAIC POWER IS ANOTHER WAY SOLAR ENERGY IS CONVERTED INTO ELECTRICITY, MS. GRUNDY!

THAT'S RIGHT, DILTON! WHY DON'T YOU EXPLAIN?



A ONE-KILOWATT ARRAY OF PHOTOVOLTAIC (GALLIUM ARSENIIDE) CELLS THAT CONVERTS SOLAR ENERGY DIRECTLY INTO ELECTRICITY HAS BEEN BUILT IN CALIFORNIA BY VARIAN ASSOCIATES AS PART OF A RESEARCH PROJECT!

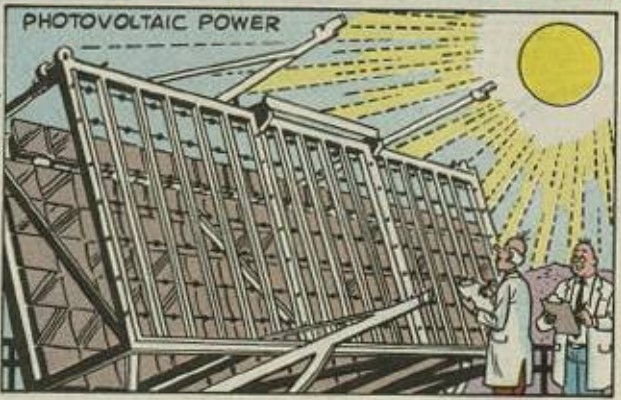

DILTON, YOU SURE ARE BRIGHT WHEN IT COMES TO SOLAR POWER!

THANKS, CHUCK! AS A STUDENT OF THE SUN, I TRY TO SHINE!



FOLLOW ME, EVERYONE! NEXT, WE'LL SEE HOW OTHER NATURAL RESOURCES PRODUCE ELECTRICAL POWER!





THIS IS A DIAGRAM OF HOW NATURAL GAS PRODUCES ELECTRICITY THAT IS CARRIED TO PRIVATE HOMES!

GEE!

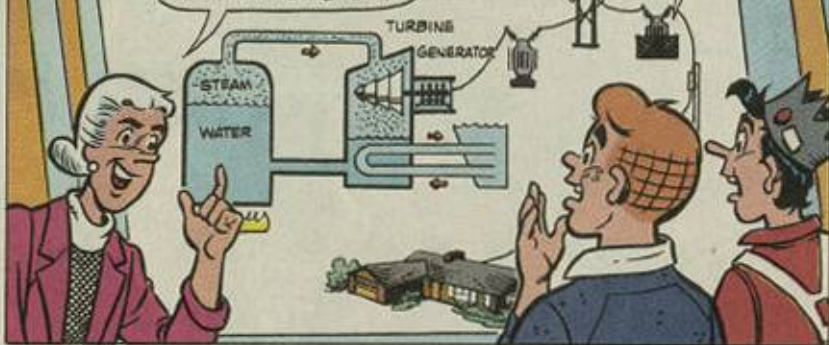

NATURAL GAS FLAMES HEAT WATER IN A BOILER...

...TURNING IT INTO STEAM, WHICH STRIKES THE BLADES OF A TURBINE...

...CAUSING IT TO ROTATE AN ATTACHED ELECTRICAL GENERATOR!

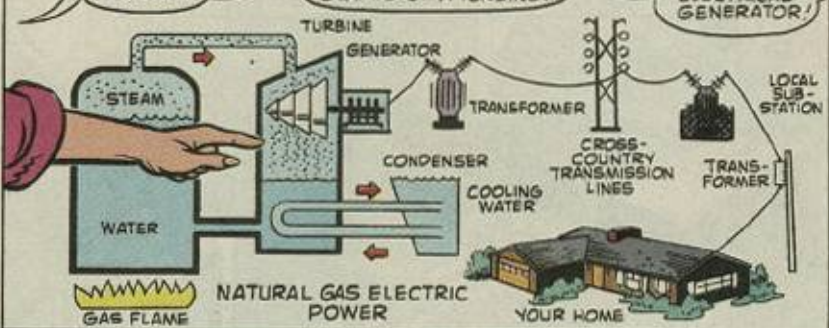

ISN'T IT TRUE THAT COAL CAN ALSO BE USED TO PRODUCE STEAM, MS. GRUNDY?

THAT'S RIGHT, ARCHIE!

HEY, ARCH! YOU'RE PRETTY SMART... FOR A MINOR!



OTHER NATURAL RESOURCES CAN ALSO GENERATE ELECTRICITY!

THAT'S TRUE, BETTY! THERE ARE MANY SOURCES OF ELECTRICAL POWER ON EARTH!



CAN YOU GIRLS NAME SOME OF THOSE SOURCES ? YOU GO FIRST, VERONICA!

OKAY, MS. GRUNDY!



"IN CALIFORNIA, PACIFIC GAS AND ELECTRIC PIPES STEAM FROM GEYSERS THROUGH A CLEANSING SYSTEM TO TURBINES THAT GENERATE ELECTRICITY! YOUR TURN, BETTY!"

GEYSER POWER



"THE TENNESSEE VALLEY AUTHORITY USES HYDRO-ELECTRIC POWER TO GENERATE ELECTRICITY FOR OVER 2 MILLION HOMES, FARMS AND BUSINESSES!"

HYDRO-ELECTRIC POWER

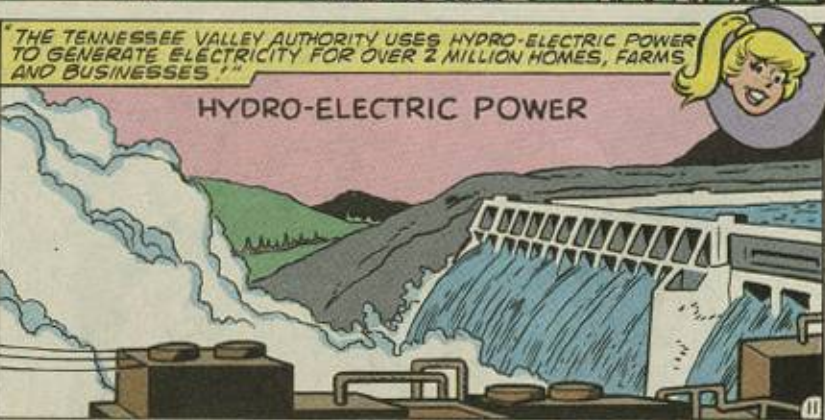



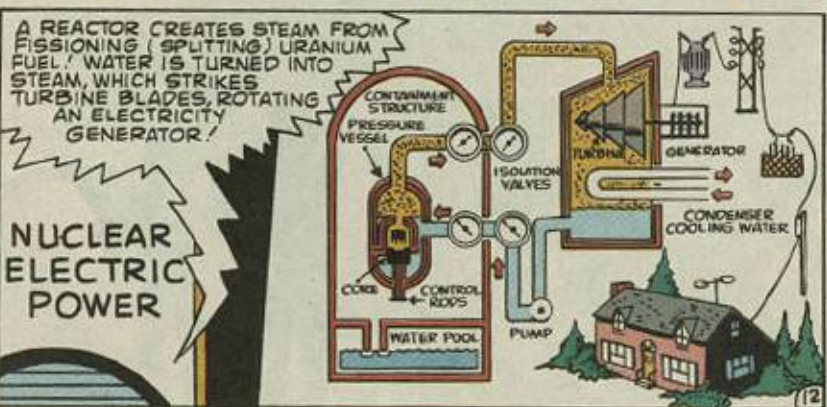

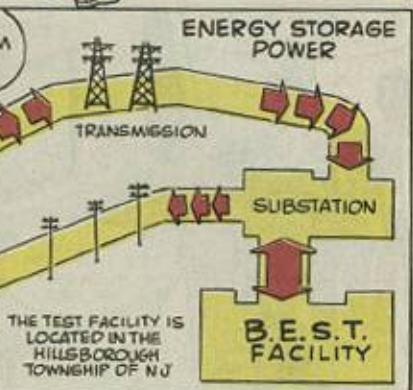



WHAT ARE WE GOING TO SEE NOW, MS. GRUNDY?

NOW WE'RE GOING TO EARN ABOUT THE HISTORY OF ELECTRICITY AND ELECTRONICS!

# THE HISTORY OF ELECTRICITY AND ELECTRONICS



ELECTRONICS IS AN EXCITING AND CHALLENGING FIELD!

DILTON'S RIGHT! THE FIELD OF ELECTRONICS IS HELPING TO MAKE OUR WORLD A BETTER AND SAFER PLACE!



THE WORLD METEOROLOGICAL ORGANIZATION NOW HAS A WORLD WEATHER WATCH WHICH USES A GEOSTATIONARY METEOROLOGICAL SATELLITE TO KEEP THE WORLD INFORMED ABOUT WEATHER MOVEMENTS!



AND MOBILE SATELLITE GROUND STATIONS SENDING ELECTRONIC SIGNALS TO SATELLITES ABOVE EARTH LET US VIEW WORLDWIDE EVENTS LIKE THE OLYMPICS ON T.V.!

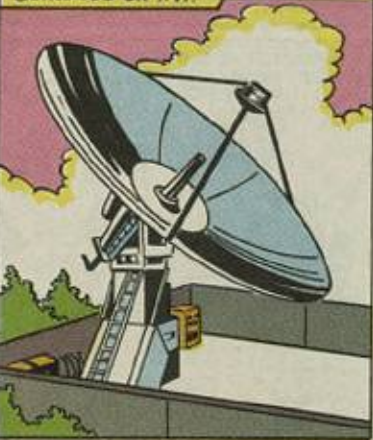

EVEN THE U.S. POSTAL SERVICE NOW USES COMPUTERS TO PROMOTE LOW COST SPEED MAILINGS! THE SERVICE IS CALLED E-COM! THE INTERNATIONAL SERVICE IS CALLED INTELPOST!



**WOW!**  
ELECTRONICS IS SURE THE WAVE OF THE FUTURE!

ACTUALLY, ARCHIE, THE STORY OF ELECTRICITY ITSELF DATES BACK OVER 2,000 YEARS!



NO ONE KNOWS FOR SURE, BUT AS EARLY AS 600 B.C. THALES OF MILETUS, GREECE, THEORIZED A CONNECTION BETWEEN ELECTRICITY AND MAGNETISM!

GEE... I MAGINE THAT!



THE ANCIENT GREEKS EVEN TRIED ELECTRIC SHOCKS FROM EELS AS A TREATMENT FOR RHEUMATIC DISEASES!



YEOW! CAN I GET A SECOND OPINION?

AN ANCIENT ELECTRIC BATTERY UNEARTHED IN IRAQ IN 1936 MAY HAVE BEEN USED FOR ELECTROPLATING METALS SOME 2,000 YEARS AGO!



THE GREAT JAPANESE ENCYCLOPEDIA OF 1712 SHOWS A PICTURE OF A "SOUTH POINTING CART" USED IN CHINA IN THE 5TH CENTURY! IT WAS SIMILAR TO A COMPASS USED BY SHIPS!



A MAGNET IN THE ARM OF THE PIVOTING MANNEQUIN CAUSES IT TO ALWAYS POINT IN THE SAME DIRECTION!





STOP DAYDREAMING, ARCHIE, AND COME ON!

NOW WE'RE GOING TO SEE THE HALL OF FAMOUS INVENTORS!



IN 1600 A.D. WILLIAM GILBERT PUBLISHED THE FIRST SCIENTIFIC STUDY OF ELECTRICITY AND MAGNETISM, CALLED "DE MAGNETE"!



THIS PAINTING IS OF AMERICA'S BEN FRANKLIN AND HIS FAMOUS KITE EXPERIMENT TO PROVE NATURAL LIGHTNING AND ELECTRICITY WERE THE SAME THING!



FRANKLIN LATER INVENTED A LIGHTNING ROD SYSTEM TO GROUND DANGEROUS ELECTRICAL CHARGES SO THEY WOULDN'T DAMAGE BUILDINGS!



HE ALSO ORIGINATED THE PLUS AND MINUS SIGNS ON BATTERIES TO INDICATE POLARITY!



I'M SURE LEARNING A LOT ABOUT PEOPLE WHO EXPERIMENTED WITH ELECTRICITY!

WE'RE JUST GETTING STARTED, BETTY!



ALESSANDRO VOLTA

ALESSANDRO VOLTA OF ITALY MADE THE FIRST PRACTICAL DESIGN FOR A BATTERY IN 1800!



IN 1831, MICHAEL FARADAY OF ENGLAND DEvised THE FIRST MACHINE TO PRODUCE ELECTRICITY FROM MECHANICAL ENERGY!

MICHAEL FARADAY



ENGLAND'S JAMES CLERK MAXWELL STUDIED THE FINDINGS OF FARADAY AND OTHERS AND USED MATHEMATICS TO PREDICT "ELECTROMAGNETIC DISTURBANCES" IN SPACE!

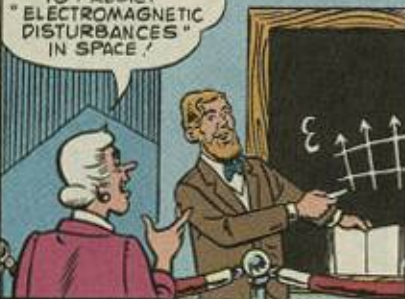

THEN HEINRICH HERTZ PAVED THE WAY FOR THE INVENTION OF WIRELESS RADIO BY ACTUALLY CREATING THE DISTURBANCES STUDIED BY MAXWELL! HE PROVED THE DISTURBANCES ACTED THE SAME WAY AS LIGHT!



WILLIAM GILBERT OF ENGLAND WAS THE FIRST PERSON TO USE TERMS LIKE: ELECTRIC FORCE, ELECTRICITY AND ELECTRICAL ATTRACTION! THE TERM "GILBERT" TODAY MEANS A UNIT OF MAGNETISM!



AMERICAN INVENTORS ALSO PLAYED KEY ROLES IN ADVANCING ELECTRONICS! JOSEPH HENRY BUILT THE FIRST ELECTROMAGNET, WHICH WAS LATER USED FOR THE FIRST DIRECT CURRENT MOTOR!





NOW HERE WE SEE MODELS OF INVENTIONS DESIGNED BY AMERICA'S MOST FAMOUS INVENTOR - THE 'WIZARD OF MENLO PARK', NEW JERSEY - THOMAS EDISON!



THIS IS A MODEL OF EDISON'S FIRST ELECTRIC LIGHT BULB!

IT SURE IS FUNNY-LOOKING!



IT SAYS EDISON INVENTED THE FIRST PHONOGRAPH IN 1877!

IT'S NOT MUCH LIKE THE COMPACT DISC PLAYERS OF TODAY!



IN 1913, EDISON SUCCEEDED IN MAKING TALKING MOTION PICTURES! BUT HIS INVENTION WAS NEVER PERFECTED!

EDISON'S MOTION PICTURES COULDN'T BE A BAD AS THE HOME VIDEO TAPES REGGIE SHOOTS ON HIS CAMCORDER!



SPEAKING OF TAPES LEADS US TO OUR NEXT INVENTION! MAGNETIC RECORDING WAS INVENTED BY VALDEMAR POULSEN IN 1899!



ACTUAL TAPE RECORDING WAS INVENTED UNTIL THE 1930'S! THIS DIAGRAM ILLUSTRATES THE PRINCIPLE OF TAPE RECORDING!

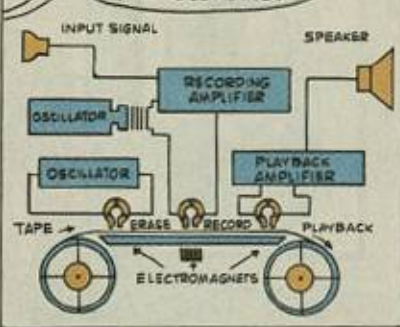

THOSE EARLY INVENTIONS LED TO THE CREATION OF OUR MODERN TAPE RECORDERS AND EVEN PRESENT-DAY VIDEO CASSETTE RECORDERS!



I'D BE LOST WITHOUT MY VCR! I TAPE ALL THE SOAP OPERAS!



I'D BE LOST, TOO! I TAPE ALL THE COOKING SHOWS!



I THINK THE GIRLS WILL FIND THE NEXT EXHIBIT MOST INTERESTING!





THESE ARE DIFFERENT TYPES OF TELEPHONES, PAST AND PRESENT!

WOW! THERE ARE ALMOST AS MANY PHONES HERE AS VERONICA HAS IN HER HOUSE!



TELEPHONES HAVE SURE COME A LONG WAY SINCE ALEXANDER GRAHAM BELL INVENTED THE FIRST ONE IN 1876!

THAT'S FOR SURE, VERONICA!



ALMON B. STROWGER MADE ONE OF THE MOST IMPORTANT IMPROVEMENTS TO BELL'S TELEPHONE! HE DESIGNED THE DIAL PHONE AND THE FIRST DIAL TELEPHONE SYSTEM THAT BEGAN OPERATING IN 1892 IN INDIANA!



LEE DE FORREST'S AMPLIFYING RADIO TUBE, KNOWN AS THE AUDION, WAS THE NEXT BIG IMPROVEMENT!

IT MADE BETTER LONG DISTANCE CALLS POSSIBLE!

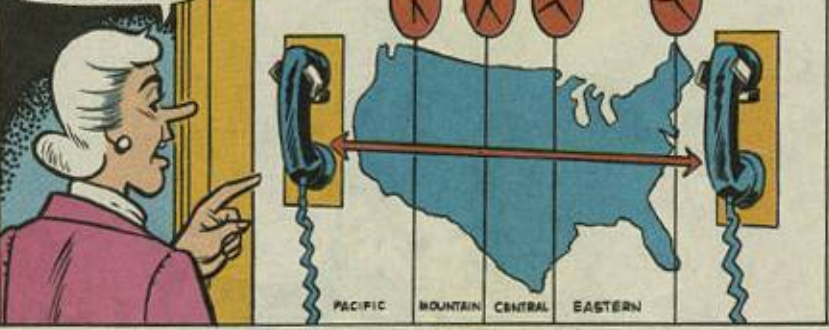

THIS IS A PAINTING OF THE CABLE SHIP *H.M.T.S. MONARCH*! DOES ANYONE KNOW WHY IT IS A FAMOUS SHIP?

I KNOW, MS. GRUNDY!



"THE MONARCH LAID A TELEPHONE CABLE THAT SPANNED THE ATLANTIC OCEAN! THE CABLE STRETCHED 2,500 MILES FROM NEWFOUNDLAND TO SCOTLAND!"



THE CABLE CARRIED ITS FIRST VOICE COMMUNICATION ON SEPTEMBER 25, 1956!

EXCELLENT, ARCHIE! THAT CABLE ORIGINALLY HAD A CAPACITY OF 37 CALLS! A NEW SUPER-CABLE OF THE FIBER-OPTIC TYPE NOW USES PULSES OF LASER LIGHT AND CAN CARRY 40,000 SEPARATE CALLS!



AMAZING!!

WHAT'S EVEN MORE AMAZING IS THAT A TELEGRAPH CABLE LINKING THE U.S. AND EUROPE WAS LAID WAY BACK IN 1869!





THIS EXHIBIT SHOWS MARSHAL MORSE IN 1837 WHEN HE BUILT THE VERY FIRST TELEGRAPH!

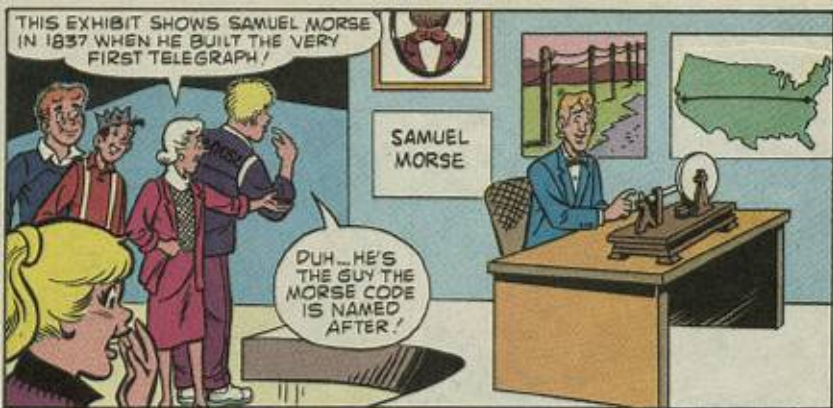

IN 1861, STEPHEN FIELD SENT THE FIRST TRANS-CONTINENTAL MESSAGE FROM CALIFORNIA TO PRESIDENT LINCOLN IN WASHINGTON, D.C.!



*DURING THE CIVIL WAR, THE FIRST TELEGRAPH PRINTER WAS INVENTED BY ROYAL HOUSE OF VERMONT!*



HEY, LOOK! IT'S MARCONI'S WIRELESS!



YEARS LATER, SHIPS ADDED SMALL ROOMS ON THEIR TOP DECKS AS COMPARTMENTS FOR MARCONI'S WIRELESS! THAT ROOM WAS CALLED A "RADIO SHACK" BY SAILORS!

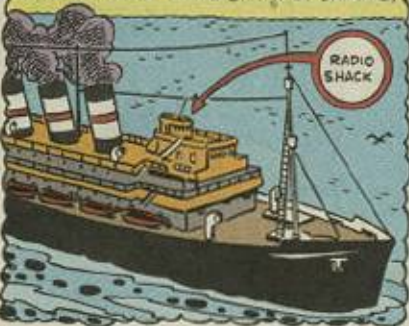

I GUESS WE HAVE MARCONI TO THANK FOR RADIO PROGRAMS!

ACTUALLY REGGIE, A CANADIAN-AMERICAN INVENTOR NAMED REGINALD FESSENDEN SENT THE FIRST MUSIC, BY WIRELESS, FROM BRANT ROCK, MASSACHUSETTS ON DECEMBER 24, 1906!



MS. GRUNDY, DIDN'T THE DEFOREST AUDION TUBE MAKE A BIG CONTRIBUTION TO RADIO BROADCASTING?

YOU'RE ABSOLUTELY RIGHT, DILTON!



THIS IS A DIAGRAM OF THE AUDION! THE TUBE MADE LOUDER SOUND POSSIBLE EVEN FROM FARAWAY STATIONS! IT CONTRIBUTED TO THE BIRTH OF MODERN RADIO!

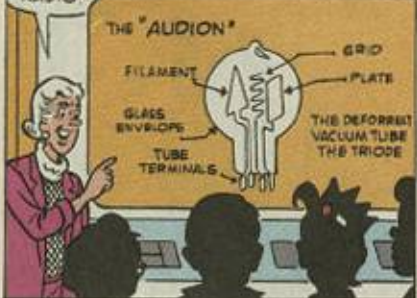

OF COURSE, EARLY RADIOS LIKE THIS ONE HAD HUGE, FUNNY-LOOKING LOUD SPEAKERS!

I'LL TAKE MY HEADSET OVER THAT ANYTIME!







THIS IS A "HANDS ON" EXHIBIT, CLASS, SO DON'T BE AFRAID TO TOUCH THINGS! THIS COMPUTER IS A TANDY 1000!

COMPUTER EXHIBIT



THE USES FOR COMPUTERS ARE ENDLESS! AT AIR TERMINALS, THEY SPEED UP THE PROCESSING OF RESERVATIONS AND TICKETS!

FLIGHT



IN SCHOOLS, THEY ARE USED AS TEACHING AIDS FOR A VARIETY OF SUBJECTS!

UNDERSTAND NOW, JUG?



SMALL BUSINESSES USE COMPUTERS TO SAVE TIME AND REDUCE PAPERWORK!



LARGER COMPUTERS HELP WITH SCIENCE RESEARCH, METEOROLOGY, AND EVEN WITH MANUFACTURING!





LET'S NOT FORGET  
COMPUTER GAMES,  
MS. GRUNDY!

RIGHT, REGGIE!

AND A PERSONAL  
COMPUTER, LIKE THIS  
COLOR COMPUTER 3,  
CAN BE USED  
TO ACCESS AN  
ELECTRONIC  
ENCYCLOPEDIA!

COMPUTERS LIKE THIS ARE FUN AND  
EDUCATIONAL! THEY MAKE DOING  
HOMEWORK EASIER!

TO ACCESS AN  
ELECTRONIC  
ENCYCLOPEDIA, PLUG  
IN THE MODEM PROGRAM  
PAK AND TURN ON  
THE POWER!

ONE SWITCH IS  
ON THE BACK OF  
THE COMPUTER!  
THE OTHER IS ON  
THE FRONT OF  
THE VIDEO  
MONITOR!

NEXT, DIAL THE  
PHONE NUMBER  
OF THE  
INFORMATION  
SERVICE YOU  
SUBSCRIBE TO!

AFTER THAT, TYPE IN YOUR SUBSCRIPTION  
ACCOUNT NUMBER! A "PROMPT" ON THE  
SCREEN WILL ASK FOR YOUR PASSWORD!  
TYPE IT ON THE  
COMPUTER!





MANNED SPACEFLIGHT

TO FINISH OUT OUR TOUR, CLASS, WE'RE GOING TO LOOK AT AMERICA'S PROGRESS IN AERONAUTICS AND AEROSPACE...

... ON THE MUSEUM'S SPACE RIDE!

YOU SHOULD LIKE THIS, REG! YOU'RE A REAL SPACE-HEAD!

GRRRR!

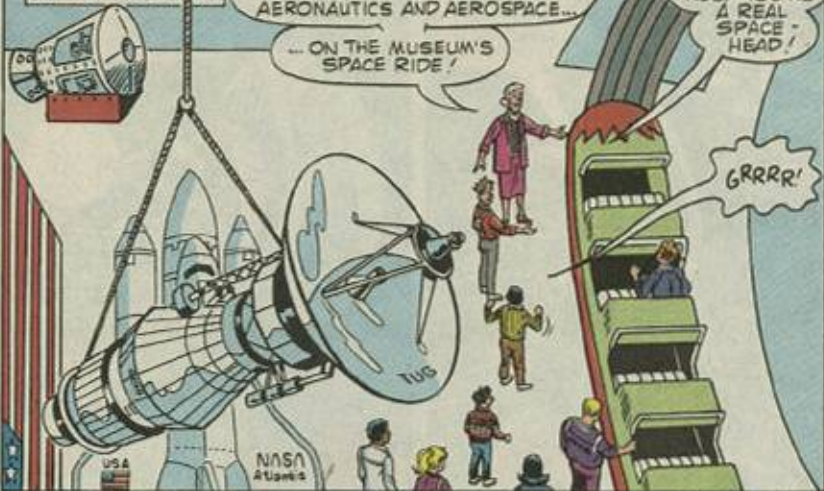

THE NAVSTAR SATELLITE ENABLES OPERATORS OF AIRCRAFT, SHIPS, SUBS, LAND VEHICLES, AND TROOPS TO PIN-POINT THEIR LOCATION WITHIN FIFTY FEET!

WOW! WHAT A HELP TO NAVIGATION!

THIS IS A MODEL OF THE NAVSTAR GLOBAL POSITIONING SYSTEM!

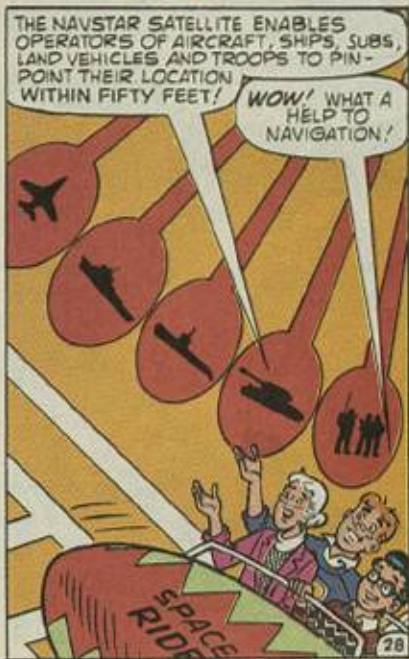



WHAT'S THIS, MS. GRUNDY?

THAT'S A MODEL OF VOYAGER 1, AN UNMANNED EXPLORER SPACECRAFT LAUNCHED IN 1977!

IN 1979, IT REACHED JUPITER AND THEN HEADED FOR SATURN!



PIONEER 10, PICTURED HERE, WAS LAUNCHED IN MARCH OF 1972!

IN 1983, IT SPED PAST NEPTUNE, THE EIGHTH PLANET IN OUR SOLAR SYSTEM!



VOYAGER 2 WAS LAUNCHED IN 1977, PASSED THE PLANET VENUS IN 1986, AND SENT BACK THE FIRST CLOSE-UP PICTURES OF THAT DISTANT PLANET!



PIONEER 10 IS NOW IN DEEP SPACE! BUT IT'S STILL SENDING BACK DATA TO EARTH! ETCHED ON A SPECIAL PLATE ON PIONEER 10 IS A MESSAGE ABOUT LIFE ON OUR PLANET!



OVER HERE YOU SEE AMERICA'S SPACE SHUTTLE CHALLENGER! IN 1984, THE CHALLENGER'S SPACE MISSION ESTABLISHED NUMEROUS RECORDS!

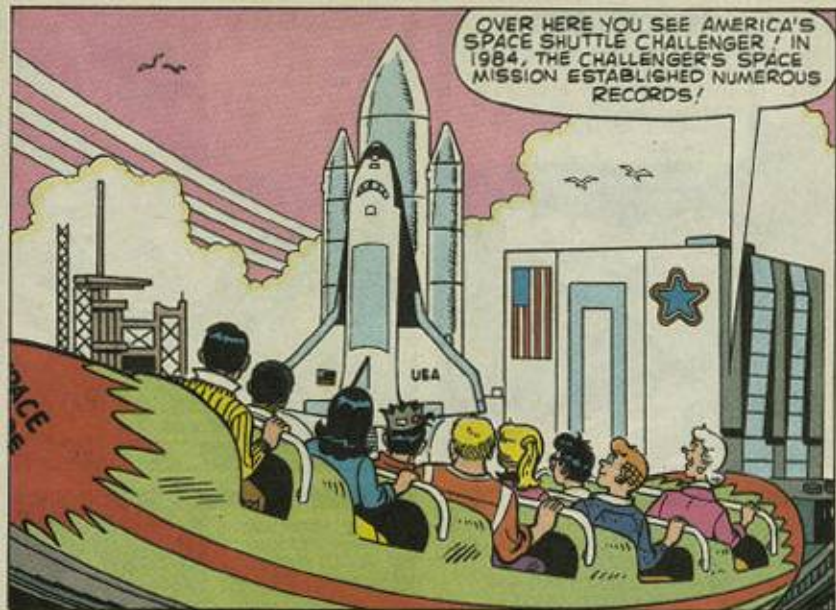

WHILE IN SPACE, ASTRONAUT BRUCE MCCANDLESS OF THE CHALLENGER BECAME THE FIRST MAN TO TRAVEL IN SPACE WITHOUT A LIFELINE!



IN 1989, THE ASTRONAUTS ABOARD THE SPACECRAFT ATLANTIS LAUNCHED MAGELLAN, THE FIRST PLANETARY CRAFT DEPLOYED FROM A SPACE SHUTTLE!



TRAVELLING AT 25,000 MPH, IT WILL REACH VENUS IN AUGUST, 1990 AFTER TRAVELLING 806 MILLION MILES!



IN MAY OF 1992, THE SPACE SHUTTLE ENDEAVOUR WENT INTO SPACE WITH A CREW OF SIX MEN AND ONE WOMAN TO PERFORM AN IMPORTANT MISSION!



THE ENDEAVOUR'S TASK WAS TO RESCUE A WAYWARD INTELSAT-6 SATELLITE THAT WAS LAUNCHED IN 1990!



A MISWIRED TITAN ROCKET HAD LEFT THE SATELLITE AT A USELESS ORBIT!

WHEN THE ORIGINAL CAPTURE PLAN FAILED, THE ENDEAVOUR CREW MADE HISTORY BY SENDING OUT THREE SPACE WALKERS TO GRAB ONTO AND HOLD THE TROUBLSOME SATELLITE!



THE ASTRONAUTS THEN ATTACHED A SOLID FUEL ROCKET PACK TO THE SATELLITE THAT LATER SENT IT UP TO ITS PROPER ORBIT!



ENDEAVOUR RETURNED TO EARTH HAVING ESTABLISHED NUMEROUS NEW RECORDS, IT WAS THE FIRST TIME THAT THREE PEOPLE WALKED IN SPACE AND THE LONGEST TIME SPENT IN SPACE BY A FEMALE ASTRONAUT AND MANY OTHER RECORDS!





WHO KNOWS WHAT THE FUTURE HOLDS? SOME- DAY WE MAY BE IN CLASSES ON AN ORBITING SPACE STATION LIKE THIS ONE!



RIGHT, MS. GRUNDY! AND WE MAY BE TRAVELING TO SCHOOL IN SPACE SHUTTLES INSTEAD OF CARS!



OKAY, CLASS, THAT'S THE END OF OUR TOUR! LET'S RETURN TO OUR BUS PROMPTLY!



REGGIE DOESN'T NEED TO TAKE CLASSES IN OUTER SPACE!

WHY NOT?

HIS GRADES ARE ALREADY OUT OF THIS WORLD!

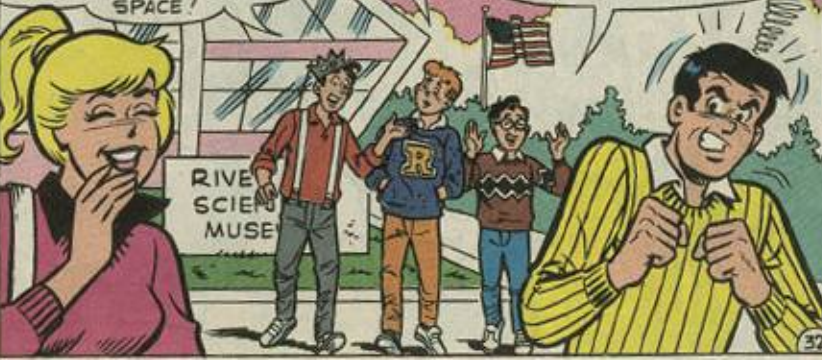

THANKS FOR TAKING US ON THIS TRIP, MS. GRUNDY! IT WAS GREAT!

YOU'RE WELCOME, ARCHIE! REMEMBER, THE FUTURE OF COMPUTERS, ELECTRONICS, AND SPACE EXPLORATION IS IN THE HANDS OF YOUNG PEOPLE LIKE YOU AND YOUR FRIENDS!

TO ADVANCE MANKIND AND MAKE THE WORLD A BETTER PLACE, YOU HAVE TO STUDY HARD AND LEARN ALL YOU CAN!

WE WILL, MS. GRUNDY! WE KNOW THAT...

...KNOWLEDGE IS POWER AND THE FUTURE BELONGS TO US!!!

RIGHT ON!



# LEARNING CAN BE FUN WITH THESE GREAT PROJECT KITS!

## 130 Project Lab Kit

- Start a Great Hobby In Electronics
- No Prior Knowledge Needed to Assemble

**29<sup>95</sup>**



Everything you need to discover electronics—the exciting way! Build a radio, AM broadcast station, electronic organ, timer, logic circuits and dozens more. With built-in speaker, 7-segment LED display, two integrated circuits and rotary controls. Safe, simple coil-spring connections. Includes fully illustrated step-by-step manual. Requires 6 "AA" batteries. 28-259



## 60-in-1 Project Lab Kit

**19<sup>95</sup>**

Teaches youngsters the basics of electricity, physics, electronics. Build a radio, metal detector, other projects. Earphone. Solderless. Requires 4 "AA" batteries. 28-261

## AM and Shortwave Radio Kit

**12<sup>95</sup>**

Hear BBC, Voice of America, WWV time, much more! Covers 3 bands: standard AM, 5.5-10 and 9-16 MHz shortwave. With earphone. Requires 2 "AA" cells. 28-176



Tune in the World

## AM/FM Project Kit

**12<sup>95</sup>**

Hear local AM and FM radio stations.

Preassembled tuner. Coil-spring assembly. Requires 2 "AA" batteries. 28-175



AM/VHF Project Kit

**12<sup>95</sup>**

## Perfect "First" Radio Kit

**6<sup>95</sup>** "Plays Forever"

Plays without tubes, transistors or batteries. Like the first radios, a crystal converts RF to audio. Covers 550-1600 kHz. 28-177



Listen to police, aviation and weather bands, plus the 550-1600 kHz AM band. Preassembled tuner. 108-135/148-174 MHz. Coil-spring assembly. Requires 9V battery. 28-163

**Radio Shack**<sup>®</sup>  
**AMERICA'S**  
**TECHNOLOGY**  
**STORE**<sup>™</sup>

# OUR ENVIRONMENT

## Who is Responsible for Keeping it Clean?

We frequently hear comments and questions regarding the environment. What effect will global warming have? Will we be able to drink our tap water in 20 years? Who is responsible for a clean environment? What will a clean environment cost?

As far as responsibility is concerned, everyone is responsible—individuals, groups and businesses. We at Tandy Corporation are vitally concerned with the protection of the environment. We continually look for methods to minimize the waste we generate, to manufacture using non-hazardous materials, to use degradable packaging, and to recycle as much material as possible.

I encourage everyone to get involved in this process, at home and at school. Concern for a healthy environment is not only good for our country, it is a sound business practice.



John V. Roach  
Chief Executive Officer and  
Chairman of the Board  
Tandy Corporation

