

Just for your  
TRS-80 COLOR  
TDP System 100  
Dragon-32

April 1983

\$2.95 U.K.  
£2.25

# The RAINBOW

THE COLOR COMPUTER MONTHLY MAGAZINE

SPECIAL SIMULATION ISSUE

With Two Special Programs!

**Bob Albrecht**  
Games

**Don Inman**  
Graphics

**Dick White**  
Tutorial

**Joseph Kolar**  
c's Basics

Play Color Poker!  
Build A Light Pen!

Introducing the RAINBUG!

—Over 30 Software and  
Hardware Reviews—

STOCK EXCHANGE

ART AUCTION

SIMULATIONS



Bulk Rate  
U.S. Postage  
PAID  
Prospect, KY  
Permit No. 18

The RAINBOW  
9529 U.S. Highway 42  
P.O. Box 209  
Prospect, KY 40059  
Address Correction Requested  
Forwarding Postage Guaranteed

©1983 Fred W. Crawford



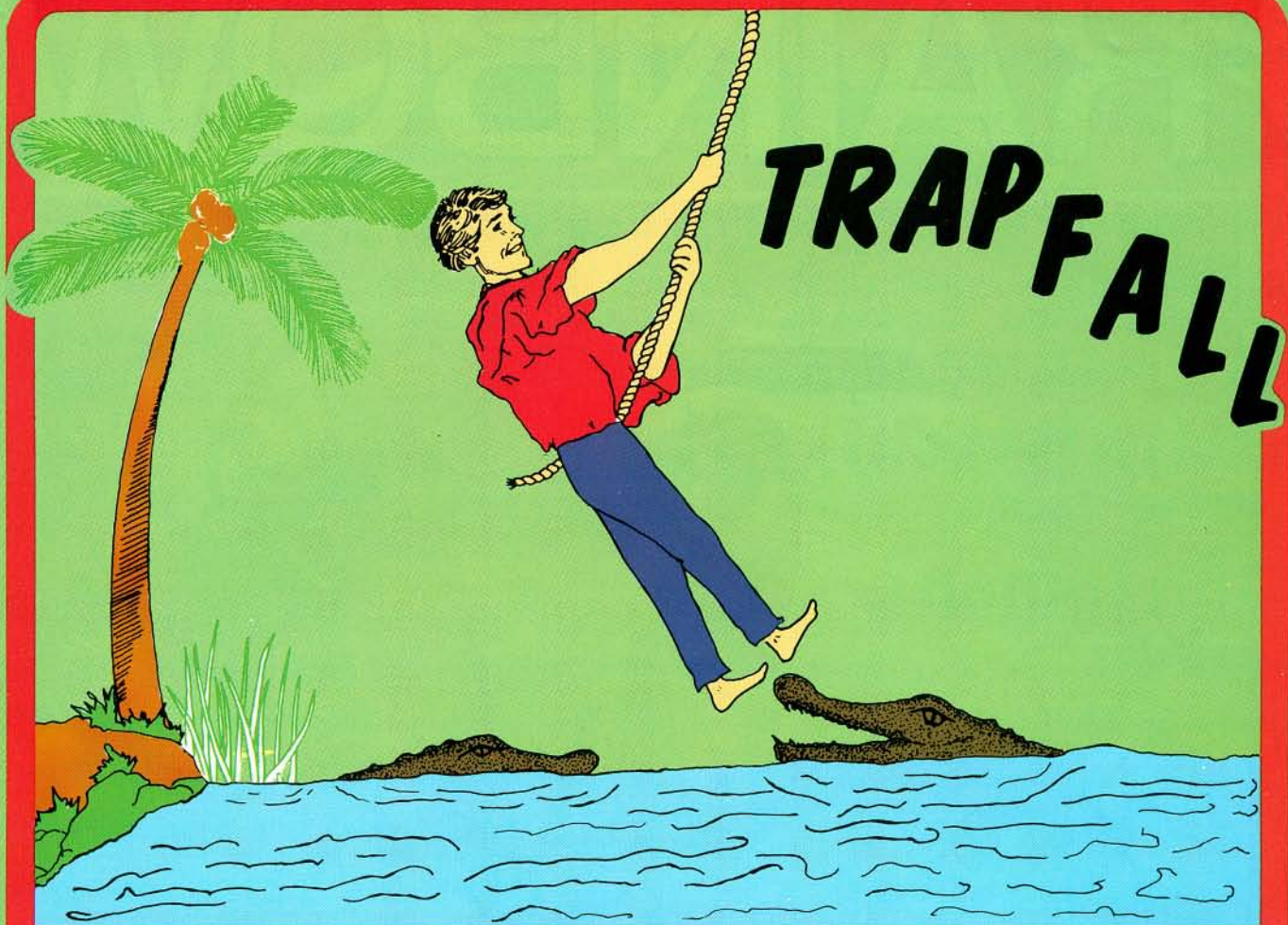

THE "PITFALLS" IN THIS GAME ARE MANY. HIDDEN TREASURES, JUMP OVER THE PITS, SWING ON THE VINE, WATCH OUT FOR ALLIGATORS, BEWARE OF THE SCORPION. ANOTHER GAME FOR THE COLOR COMPUTER WITH THE SAME HIGH RESOLUTION GRAPHICS AS "THE KING."

REQUIRES 16K.

\*\*\*MACHINE LANGUAGE\*\*\*

**\$27.95** TAPE

## TOM MIX SOFTWARE

• FOR THE COLOR COMPUTER & TDP 100 • 3424 College N.E., Grand Rapids, MI 49505 (616) 364-4791 •



ADD \$1.00

MICHIGAN RESIDENTS ADD 4% SALES TAX • LOOKING FOR NEW SOFTWARE  
\*TO PLACE ORDERS AFTER 5:00 P.M. CALL OUR BBS AT 616-364-4791





From Computer Plus to YOU...

# PLUS after PLUS after PLUS

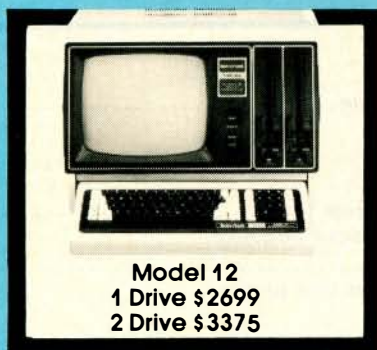

Model 12  
1 Drive \$2699  
2 Drive \$3375



Color Computer 16K \$235  
w/16K Ext. Basic \$305  
w/32K Ext. Basic \$420



Model III 16K \$699  
Model III 48K  
2 Disk & RS232 c \$1549



Okidata 80 \$320  
Okidata 82A \$399  
Okidata 92 \$510



Color Computer Disk Drive  
Drive 0 \$470 Drive 1 \$299



Smith Corona TPI  
Daisy Wheel \$555

**BUY DIRECT** Here are just a few of our fine offers...  
call TOLL FREE for full information.

### COMPUTERS

Model 12 64K 1 Drive	\$2699
Model 12 64K 2 Drive	3375
Model III 16K	699
Model III 48K	764
Model III 48K	
2 Disk & RS232 c	1549
Color Computer 16K	235
Color Computer 16K	
w/extended basic	305
‡Color Computer 32K-64K	
w/extended basic	420
Pocket Computer 2	165
Model 16 1DR 128K	4199
Model 16 2DR 128K	4799
DT-1 Data Terminal	599
PT-210 Portable Terminal	779

### MODEMS

Lynx Direct Connect MII/MIII	235
Hayes Smart Modem II	235
Hayes Smart Modem 1200	565
Novation Smartcat 1200	459
Novation J-CAT	125

R.S. Acoustic Coupler AC-3	129
R.S. Modem I D.C.	129
R.S. Modem II D.C.	199
<b>PRINTERS</b>	
Daisy Wheel II	1715
DWP-410	1320
Smith Corona TPI Daisy Wheel	555
Epson MX80	Call
Epson FX80	Call
Epson MX100	
CGP-115	199
DMP-100	315
DMP-200	599
DMP-400	1010
DMP-500	1539
DMP-2100	1779
Okidata 80	320
Okidata 82A	399
Okidata 83A	655
Okidata 84 Parallel	999
Okidata 92	510
Okidata 93	859
P.C. Plotter Printer	180

### DISK DRIVES

R.S. Model III 1ST-Drive	650
Tandon 40 Track MI	289
Color Computer Drive 1	299
Color Computer Drive 0	470
Primary Hard Disk MII	3099
Primary Hard Disk MIII	2199

### ETC.

CCR-81 recorder	52
C. C Joysticks	22
16K RAM N.E.C. 200 N.S. chips	25
64K Ram Chips	75
Coco FHL Flex D.O.S.	69.95
32K Microbuffer Inline	229

### SOFTWARE

Brand Name Software •  
Send for listing.  
R.S. Software 10% off list  
Parallel Printer Cables are  
available for most computers.

‡Color Computer 64K requires  
Disk 0 and D.O.S.

Since 1973 —  
We have the lowest possible  
Fully Warranted Prices AND  
a full complement of Radio Shack  
Software.

Prices subject to change without notice.  
Not responsible for typographical errors.  
TRS-80 is a registered trademark of Tandy Corp.



**TOLL FREE**  
**1-800-343-8124**

# computer plus

P.O. Box 1094  
480 King Street  
Littleton, MA 01460  
617-486-3193

Write for your  
free catalog



# Under the Rainbow

## Feature Articles

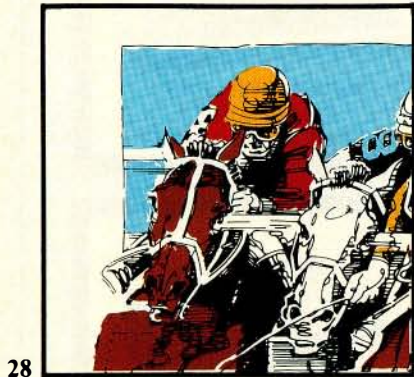

28



44

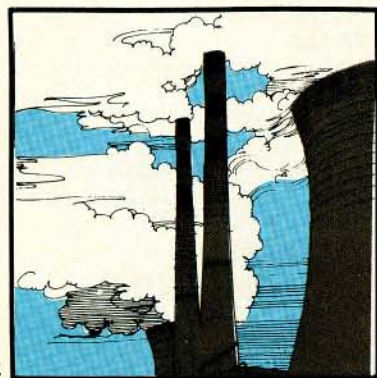

112

COVER acrylic © 1983 by Fred Crawford.

<b>Flashy Program, By Thunder/John Plaxton</b> .....	16
<b>Graphics</b> A bolt from the CLS3.	
<b>Save Your Chips/William Clements Jr.</b> .....	18
<b>Hardware</b> Install a "Power On" light.	
<b>Tick Tock, CoCo Clock/Alexander B. Trevor</b> .....	20
<b>Home Control</b> Your computer becomes a timepiece.	
<b>First Saturday In May/Rob Becker</b> .....	28
<b>Game</b> Horse racing for CoCo—Just in time for the Kentucky Derby.	
<b>A Capital Program/Chuck Faessler</b> .....	34
<b>Education</b> Can you name all 50 state capitals?	
<b>CoCo Cabinet/Curtis Bauter</b> .....	36
<b>Construction</b> One man's answer of "where to put it."	
<b>The RAINBUG Monitor/Dan Downard</b> .....	44
<b>Utility</b> The first of four parts aimed at developing our own monitor program for you.	
<b>Iowa Lemonade/Paul French</b> .....	60
<b>Simulation</b> Can you make money operating a lemonade stand?	
<b>Graphics Grid/T. Gray</b> .....	73
<b>Graphics</b> Use a magic slate to sketch pictures.	
<b>The New Shell Game/Robert W. Ericson</b> .....	74
<b>Home Management</b> Spectaculator shells can enhance your use of this program.	
<b>Keytones Help Input/James Provost</b> .....	77
<b>Utility</b> The keys are alive with sound.	
<b>Right Justify Numbers/Mike Hall</b> .....	77
<b>Help</b> Lining 'em up.	
<b>Modems Can Be Your Friends/Harry Hardy</b> .....	78
<b>Communication</b> Let's communicate.	
<b>What's Going On In There?/Richard Krankoski</b> .....	82
<b>Utility</b> Looking at memory in real time.	
<b>Smile, CoCo!/Bruce Rothermel</b> .....	88
<b>Pictures</b> Photographing your screen.	
<b>Build A Light Pen/Ted Hasenstaub</b> .....	90
<b>Hardware</b> With charts to aid you.	
<b>Tie An ASCII Border 'Round CoCo/Ray Gauvreau</b> .....	104
<b>Graphics</b> And your screen will love you.	
<b>Micro-Meltdown/Chris Latham &amp; John Erickson</b> .....	112
<b>Simulation</b> Our feature program features your own nuclear reactor.	
<b>Know When To Hold 'Em.../Joseph Kohn</b> .....	162
<b>Game</b> Colorful Draw Poker.	
<b>Offset Easy/Edgar Poulin</b> .....	172
<b>Help</b> How to offset load—higher or lower.	
<b>Living With One Disk/Melvin Hefter</b> .....	174
<b>Tutorial</b> The best of times, the worst of times.	
<b>Unhexing Hex/Jim Schmidt</b> .....	178
<b>Tutorial</b> If hex has you hexed, this will help you hexorcise it.	
<b>Three Easy Pieces/Stephen Lai</b> .....	188
<b>Graphics</b> The animator's art.	
<b>Patch The Patch/Roger Schrag</b> .....	194
<b>Utility</b> Refinements to the author's EDTASM+ Patches.	
<b>Well, Treble My Clef/Larry Konecky</b> .....	218
<b>Music</b> Repeat these notes.	
<b>Crunch These Numbers/Mark Laessig</b> .....	234
<b>Statistics</b> And make graphs, too.	



## Departments

Letters To Rainbow/Our Readers.....	6
Rainbow Scoreboard.....	12
PRINT #-2,/Lawrence C. Falk .....	13
Editor's Notes.	
Building A Rainbow/Jim Reed .....	14
A many-hued preview to this month's issue.	
CoCo Counsel/Tom Nelson.....	56
The legalities of marketing software.	
Corrections .....	86
Education Notes/Steve Blyn .....	96
A vowel checker uses strings.	
Assembly Corner/Dennis Lewandowski .....	98
Let ML handle BASIC's chores.	
Using Graphics/Don Inman.....	106
Let's make some regular polygons.	
About Your Subscription .....	126
Education And CoCo/Paul Kimmelman .....	224
Looking at LOGO.	
Submitting Material To Rainbow .....	132
Turn Of The Screw/Tony DiStefano .....	146
Reduce that RF interference.	
The Pipeline/Staff.....	158
The Dragon's Byte/Bill Nolan .....	170
Better monster management.	
Received And Certified/Staff.....	198
Basic Training/Joseph Kolar .....	200
Care to share?	
Back Issue Information .....	202
Bits And Bytes Of Basic/Richard White .....	210
Cassette file management technique.	
RAINBOW Info .....	216
GameMaster's Apprentice/Bob Albrecht .....	226
Different dice make different programs.	
Advertiser Index .....	

## Product Reviews

3D Tic Tac Toe/ Kenneth Peters ...	52	Kamikaze .....	42
64K Screen Expander .....	100	LLIST-Rite.....	204
Android Attack .....	232	Panostyk .....	214
Bar Zapper .....	136	Preschool Packs 1, 2, 3 .....	192
Beyond The Cimeeon Moon.....	152	Protectors .....	102
Bridge Tutor I.....	148	Robot Battle .....	140
Catch 'Em .....	72	Shark Treasure .....	144
Conquest of Kzirgla .....	105	Space Race .....	24
Crystal Revenge .....	160	Spanish One .....	40
Death Star .....	150	Speak Up! .....	132
Doubleback .....	72	Spectrum Switcher .....	207
Eight-Bit Bartender .....	208	Super "Color" Disk Zap .....	138
Electricity Consumption		Super Pro Keyboard .....	81
Monitor .....	26	Synther-7.....	156
File Cabinet .....	134	Weather Watch.....	80
Gazon .....	240		

**NEXT MONTH:** The printed word will be featured in next month's edition of *the Rainbow*.

We'll have a bunch of word games to amuse you—and to help illustrate some string handling techniques. Plus, some word processing information and—for the first time—the world's most comprehensive chart for converting control codes from one printer to another.

AND... More games, more tutorials, the Scoreboard, and more information and reviews on CoCo than you can find anywhere else. It is all coming in next month's *Rainbow*!

**AN IMPORTANT ANNOUNCEMENT CONCERNING SUBSCRIPTIONS IS ON PAGE 79**

## The Rainbow

**Lawrence C. Falk**  
Editor

James E. Reed  
Managing Editor

Courtney Noe  
Associate Editor

Sally Nichols  
Art Director

Jerry McKiernan  
Assistant Art Director

Suzanne Kurowsky  
Editorial Assistant

Bob Albrecht  
Steve Blyn

Don Inman  
Joseph Kolar  
Paul Kimmelman  
Dennis Lewandowski

Bill Nolan  
Charles Roslund  
Dick White  
Contributing Editors

Patty King  
Advertising Manager

Patricia H. Hirsch  
General Manager

Ivanka Kleier  
Customer Service Manager

Donna Shuck  
Bookkeeper

Monica Wheat  
Research Assistant

Wendy Falk  
Transportation

The *Rainbow* is published every month of the year by FALSOFT, INC., 9529 U.S. Highway 42, P.O. Box 209, Prospect, KY, 40059. Phone (502) 228-4492. The *RAINBOW* and the *Rainbow* logotypes are © Trademarks of FALSOFT, Inc.

Entire contents © by FALSOFT, Inc., 1983. The *RAINBOW* is intended for the private use and pleasure of its subscribers and purchasers and reproduction by any means is prohibited. Use of information herein is for the single end use of purchasers and any other use is expressly prohibited. All programs herein are distributed in an "as is" basis, without warranty of any kind whatsoever.

TRS-80, Color Basic, Extended Color Basic, Scripsit and Program Pak are © trademarks of the Tandy Corp. CompuServe is a © Trademark of CompuServe Inc.

Subscriptions to the *RAINBOW* are \$22 per year in the United States. Canadian and Mexican rates are U.S. \$29. Surface mail to other countries is U.S. \$55, air mail U.S. \$87. All subscriptions begin with the next available issue.

Limited back issues are available. Please see notice for issues which are in print and costs. Payment accepted by VISA, MasterCard, American Express, Cash, Check or Money Order in United States currency only.



# RAINBOW

## THE HAZARDOUS LEM STATEMENT

Editor:

AHA! On page 7 of the February 1983 issue, upper-right corner, you said that nothing you enter from the keyboard can hurt your machine. That *ain't* what the repair technician told me when I entered a glass of lemonade into the keyboard! And, I completely eliminated all the key-bounce problems that I'd been having. They went down and stayed down. No bouncing there.

Pete Jikeen  
Red Bank, TN

## INFORMATION PLEASE

Editor:

I have been told a major national magazine published an article on the hazards of using color TVs older than 10 years with microcomputers. I have not read the article, but apparently the danger would be exposure to harmful radiation. If this is the case then I have something else to worry about besides wierdos doctoring up my aspirin because—yes—my CoCo is hooked up to an ancient RCA. Can somebody set my mind at ease, because my mother is worried about me.

Now you know who told me.

Charles H. "Sam" Muncy  
Grafton, WV

**Editor's Note: Sorry, Sam, we have not heard about this article. Are you sure your Mom doesn't just want you to have more fresh air and sunshine?**

Editor:

Thanks to SIR RANDOLPH OF THE MOORS I have decided to expand my 16K computer to 32K and get *Rainbow on Tape*.

Although the program could have been rewritten and shortened considerably I can tell from the listing that it should be an enjoyable game. My congrats to the author and winners of your contest.

So far, I think you have a great magazine and find myself checking the mailbox anxiously for the next issue(s).

Could you possibly tell me how to merge or (concatenate) BASIC programs? The reason I ask is I had agreed with a friend to type in half of Randolph on my 16K and he the other half on his 32K and then we would merge the two halves into one program on his computer. We tried *PEEKING* and *POKEing* start and end address but it did not work. Finally, after about an hour of useless attempts, I decided to convert my Mr. Edit program and just read the first half in in ASCII and then the second half in ASCII all

into one buffer. After saving my buffer on tape I was able to reload the two halves as one program and *RUN* it. There must be an easier way!

George W. Chaffee  
Lowell, MA

**Editor's Note: There are several programs available to merge Basic listings and we've printed one routine in the Rainbow.**

Editor:

I have had my Color Computer for a month and a half now and am very pleased with its capabilities. Until I came across your magnificent magazine I was at a total loss of information on where to go for help. Your magazine has really helped me in getting started.

I guess the real reason why I'm writing you is for advice on upgrading my memory. I currently have 16K Extended BASIC, but want to go to 64K (if possible). I've seen advertisements for do-it-yourself kits which go up to 32K and also ads that sell chips for 64K expansion (E-Board). Is it possible for me to upgrade my system to full 64K, or can I only have a certain amount at a time? Also, how can you tell which type of board you have in your color computer? (i.e., D,E, . . .)

I'd appreciate very much if you could give me an answer.

Loren J. Dickey  
Tuscon, AZ

**Editor's Note: You can tell which board you have by looking at the serial number (through the air holes on the right side—use a flashlight). Your 64K is really two banks of 64K, but you can move the operating system to RAM and get more memory. It, however, is not a full 64K of open RAM—more like about 48K.**

Editor:

Can you persuade Roger Schrag to do for Radio Shack's *Color File* what he did for *EDTASM+*? By using Micro Technical Products *ROML*, I have *Color File* on disk, but must still use tape for storage. I'm a duffer at assembly language, so am not yet able to discover the patches necessary to do the change from tape to disk storage for myself. I just bought Radio Shack's *Personafile* on disk, but *Color File* seems much more versatile in some ways, since it allows sorts in seven fields instead of the two in *Personafile*.

One more thing. Jorge Mir's program for using 64K is interesting, but when I tried to use it with his *Unidatfl* I kept getting an OM error in the line that clears string memory, even when I *CLEAR* only 22,000. I

bought the tape of his *Unidatfl* directly from him last summer, and I haven't yet tried to upgrade it as suggested by Arnold Weiss in his December article.

See you in April at Rainbowfest!

Max Shank  
Chicago, IL

Editor:

I've acquired a DWP-410 and interface for my 32K (upgrade) CoCo. I'd love to hear from anyone with a similar setup to compare notes. The vendors I've used—Computer Plus and Jarb—have been excellent.

Finally, keep it comin', *Rainbow*. There's no other single source I learn as much from.

Alan Jay Weiss  
Summit, NJ

Editor:

I am glad that *the Rainbow* is doing so well, but sad that so many back issues are out of stock. I am a newcomer to the Color Computer and am glad to see so much available for it. I would appreciate hearing from any readers who might be able to supply me with back issues (Vol. I #11, Vol. II #'s 1-7).

Not wishing to spend all of my time studying BASIC, I quickly purchased an Adventure game: *Raaka-tu*. Wow! As a United Methodist Minister interested in ecumenical affairs, I was not prepared to be the sacrificial object on the high priest's altar—and so many times. I have not made it past this point and would appreciate some pointers (ouch! The statue's arrows are sharp, too!) or suggestions on where to go from here.

Finally, I have obtained an Axiom EX800, 80-column printer and would like some help in hooking it up to the Color Computer. I can get it to work, but the resulting printed page is not what I type into the computer. Help!

Thank you for a very fine publication. I have received much better service from you than any other publication for the Color Computer and I appreciate it very much.

Rev. Richard A. Lochner  
Topeka, IN

Editor:

I love your magazine and don't see how I could get along without it.

There is one thing I need to know. I have a 16K CoCo and want/need 32K. Trouble is I have Color and Extended Color BASIC, version 1.0, and A "D" board.

Is there any way I can piggyback 16K chips? Do I only have to replace Color BASIC with version 1.1? Or is more involved? I don't have the \$ for 32/64 MOD either from Radio Shack or myself.

Dave Smallman  
Strongsville, OH







## IT AINT VEGAS

Editor:

I have a complaint I must voice about programmers who offer Las Vegas type games such as Craps or Blackjack for sale in the pages of your magazine. Before they put such a program on tape they ought to at least learn the rules of the games as played in the casinos.

For instance I don't know of any casino which pays you for five cards and under 21, nor does the dealer win if he holds such cards. If the dealer has an ace as an up card when the player takes insurance, the game should either inform the player that the dealer does not hold blackjack and play continues, or the hand should be exposed if the dealer does and play on that particular hand is halted with no cards being dealt to player.

I have gotten these so-called casino games from two of the advertisers in *the Rainbow* and I acquired them on the basis that they were advertised as true Las Vegas type games. Well they *ain't*. No serious player of Blackjack or Craps would play the games the way they are programmed.

Thank you for putting out an excellent magazine for users of the Color Computer. I read each issue from cover to cover including the ads.

Harry Norkin  
Thousand Oaks, CA

## HINTS 'n' TIPS

Editor:

I have come across a method for achieving a PCLEAR 0 effect for Disk Extended Color Basic. It is as follows:

1. On power up, POKE 25,14 and then POKE 26,0

2. Type NEW and PRINT MEM. There should be 12584 bytes free.

I have not had a failure with this method as of yet, and have SAVED, LOADED, and created disk files with this method. All the rules for PCLEAR 0 for non-disk systems apply here as well.

Congratulations on your new format. I was a bit blinded by the glossy pages, but if that is the price for beauty, pay it.

John. C. Roth  
Salem, OR

Editor:

In response to the letter by John Schmidt (February 1983) concerning how to get the audio from SOUND and PLAY commands to tape, the solution is quite simple. All sounds made by CoCo are automatically transferred to cassette if the record button is pressed. Thus, all that remains is to type MOTOR ON or pull out the small gray plug on the tape recorder to move the tape.

Several people have asked how to put a screen print program made for a 16K machine into the upper memory of a 32K machine (so the memory of a 32K machine won't be cut in half). Well, I don't know how, but a POKE 25,64:NEW will put the BASIC program past the screen print program thus giving 16K of memory instead of 6K (taking into consideration PCLEAR 4 has been typed in). However, several steps must be taken.

First, all the PCLEAR values in the program must be deleted. Second, the commands RUN and NEW will give a SYNTAX ERROR (except one when POKE 25,64:NEW is typed in). To operate the BASIC program, type GOTO "second line number" (typing GOTO "first line number" will also result in a SYNTAX ERROR, so put in a REM line before the first official line number in the program). Third, be sure to type in CLEAR 200,32767 or something might go wrong. By the way, all the graphic pages are reserved so all the PMODES can be used.

I enjoy your magazine very much.

Paul Gani  
Marshfield, WI

## OUR ENGLISH CHANNEL

Editor:

My interest started one day when I was reading (in bed) a British computer magazine with a review of the Dragon-32, a new computer made in Wales. On reading the specifications, my eye caught the word "6809 processor"—the same as the Tandy TRS-80 Color Computer.

I suddenly realized the implication and jumped out of bed shouting "Eureka." My wife thought I had gone mad.

We get a copy of *the Rainbow* airmailed to us. We hope that *Rainbow* will continue to grow over here. I am sure that when the Dragon reaches the you in the States that *the Rainbow* will feature Dragon articles. Happy computing to you all.

Harold Berkeley  
Prestwich, Manchester, England

## CLUBS, CLUBS, CLUBS

Editor:

In order to get in contact with more CoCo owners here in Mexico City, I will found the Mexico City Color Computer Club. I have developed several programs which I would like to have others benefit from.

Every time I start up my computer, I have to turn it off and on until it works properly. In the years I've been using CoCo, I have learned that it only works well when all the letters look exactly the same color. I think this is a problem with the electric energy, since here in Mexico, it varies very much. If I don't turn it off and on I don't get the right color, it always hangs up, displaying the famous alpha sign (PRINT@). My address and phone: Laja # 232, 01900 Mexico D.F., Tel. 5-68-78-75.

Marcelo Luft  
Mexico City, Mexico

Editor:

A CoCo Special Interest Group meets the third Saturday of every month at JARB Software, 1636 D Avenue, Suite C, National City, CA 92050. Interested CoCo users are welcome to attend or to contact CoCo SIG at (619) 474-6213.

Joe Bennett  
San Diego, CA

Editor:

I would like to thank all companies (especially *the Rainbow*) that have not forgotten us Europeans and do ship overseas. For

example, when I ordered some materials from Mark Data Products and Tox Mix Software, it took only 21 days from the day I mailed my order to the day I received the products. That's what I call service! Please, all dealers, mark your overseas shipping charge on your ads. I'd feel a lot more comfortable about sending my money in if you did.

By the way, *Donkey King* is an excellent program: you can't go wrong with that one. How come nobody has translated the original *Colossal Cave* adventure on the Color Computer? It fits in 32K, doesn't it?

Could you tell me what is the "magic number" on Nanos Systems reference card? How to disable the auto start on *Astro Blast* and *Cave Hunter*?

How come *Rainbow on Tape* doesn't ship overseas? They could at least ship back issues. There is no sense in typing an adventure in. First, you learn most of the tricks and solutions; secondly, you are bound to get at least one '? SN ERROR' during the game.

If there are any Finnish *Rainbow* readers out there, please call me at (90) 748-521 and we'll get together and form a club.

Lastly, I would like to thank *the Rainbow* for being what it is: The best source of Color Computer information and a great computer magazine. (I bet you are getting tired of hearing that!)

Timo Talasmaa  
Met Sopurontie 9A 12  
SF 00630 Helsinki 63  
Finland

**Editor's Note: Some things we never get tired of hearing. Thank you! And, yes, *Rainbow on Tape* is available worldwide.**

Editor:

I am interested in helping form a 80C User Group in the Chattanooga area. If anyone is interested they may contact me at 3617 Cline Road, East Ridge, TN 37412 or phone (615) 867-5682.

Keep up the excellent work.

Jim Perkins  
East Ridge, TN

Editor:

There is finally a users group just for CoCo owners in the Milwaukee area. It is called CoCo-MUG (Color Computer-Milwaukee Users Group) and it is looking for new members. Anyone interested should contact CoCo-MUG, c/o Tom Fandre, 2420 Misty Lane, Waukesha, WI 53186, (414) 542-0600.

Steve Koszuta, Secretary  
Milwaukee, WI

Editor:

We would like to announce the formal formation of the Miami Valley Color Computer Club serving Miami and Shelby counties in Ohio. The MVCCC meets the second Sunday of each month at the Hayner Cultural Center, 301 W. Main Street, Troy, Ohio. The club currently has more than 25 active members and is growing daily.

R. Douglas Wales, President  
Troy, OH



**624 KBYTE  
SYSTEM!**



**New  
3" disk  
cartridge**

## **COLOR AMDISK-III COMPATIBLE.**

The AMDISK-III micro-floppy disk system is an engineering breakthrough in disk size, storage capacity, media protection and user convenience. It's fully compatible with your Radio Shack® Color Computer. Enjoy a full 624 KByte† (formatted) storage capability and the extra convenience of the new 3" hard plastic encased diskettes. They fit into a shirt pocket and are easy to mail, too.

The AMDISK-III drive system is ruggedly constructed for years of trouble-free operation, and is backed with our 90 day warranty on parts and labor.

Just circle the reader service number to receive complete specifications.

\*Radio Shack is a registered trademark of Tandy Corporation.  
†Requires recording on both sides.

2201 Lively Blvd. • Elk Grove Village, IL 60007  
(312) 364-1180 TLX: 25-4786

**AMDEK** CORP.

**Amdek . . . your guide to innovative computing!**



# ColorQuest™

## GAMES

For The TRS-80 Color  
and TDP System 100

Fast Machine Code • Hi-res Color Graphics • Exciting Arcade Action and Sound

## Fembots' Revenge™

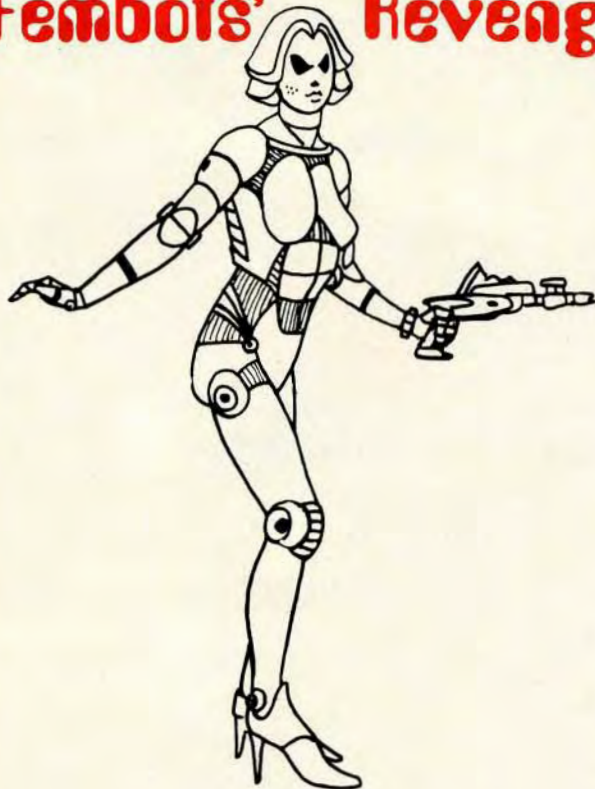

**3-D GRAPHIC ADVENTURE**

Make love not war? Not with these sultry FEMBOTS! What a tale you'll tell IF you live to tell it! Cold steel never felt so HOT! The color and excitement of ARCADE ACTION combined with the sophistication, intellectual challenge and skill of an ADVENTURE GAME doesn't fully describe this cosmic shoot'em up.

**16K Tape \$29.95**

**32K Disk \$34.95**

## BEYOND THE CIMEEON MOON™



by Kevin Herrboldt & Tim Nelson

**3-D GRAPHIC ADVENTURE**

A dead star . . . A derlict vessel . . . or is it? Trapped within you must venture the corridors; defend yourself against the merciless gauntlet of agents of the machine mind. A real-time, high-res, 3-D science fiction adventure game of mind-blowing magnitude.

**16K Tape \$24.95**

**32K Disk \$29.95**

## Adventure Trilogy™

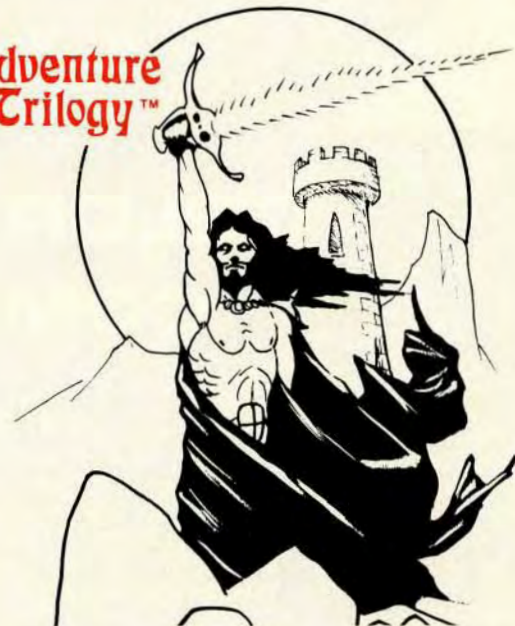

by Kevin Herrboldt & Tim Nelson

**3-D GRAPHIC ADVENTURE**

Clash steel with thy foe in the arena of gore. Proved worthy, go in quest of the elusive Eye of Dazmor. If ye findest the orb, hast ye the might to ward off skem and the fortitude to restore the Eye? The ultimate high-res, 3-D quest for even the most experienced adventurer!

**16K Tape \$24.95**

**32K Disk \$29.95**

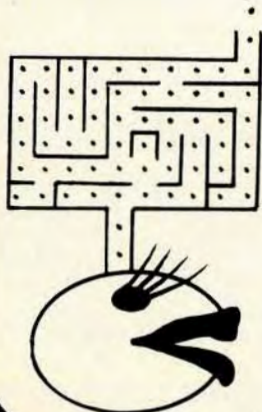

## MS. NIBBLER™

by Tom Czarnecki

The ONLY Ms. game around. A must for your PAC-like game collection.

**16K Tape \$19.95**

**16K Disk \$24.95**

TRS-80 is a trademark of Tandy Corp.



For Orders  
ONLY Call  
Toll Free

# 1-800-328-2737

Fast Machine Code • Hi-res Color Graphics • Exciting Arcade Action and Sound

## INTERCEPTOR™

by Scott Snyder

Goes beyond "DEFENDER" and "STARGATE" to offer the most realistic ARCADE simulation possible. Warp speed action, multi-colored terrain and long-range viewer make this game tops.

16K Tape \$19.95  
32K Disk \$24.95

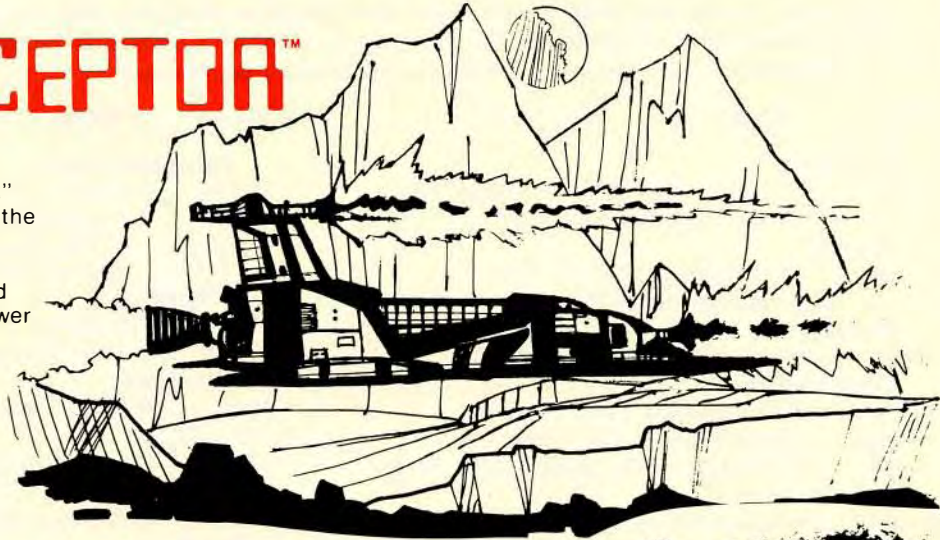

## VEGAS GAMEPAK™

by Dan Nelson

Why fly to VEGAS when you can have a casino at home! The VEGAS GAMEPAK is five action packed games with great graphics & sound. SLOT MACHINE - BLACKJACK - UP AND DOWN THE RIVER - CRAPS & KENO.

16K Tape \$19.95 16K Disk \$24.95

## THE NIBBLER™

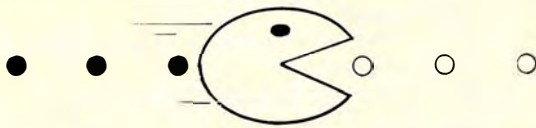

by Tom Czarnecki

Fast paced maze chase game will entertain the entire family.

16K Tape \$19.95  
16K Disk \$24.95

## ColorQuest™

A Division of Softlaw Corp. 612/881-2777  
9072 Lyndale Ave. So., Minneapolis, MN 55420

**AUTHORS' SUBMISSIONS ARE ENCOURAGED**

Available at Dealers everywhere.  
If your Dealer is out of stock ORDER DIRECT!



## KOMET-KAZE™

by Tom Czarnecki

Shades of smartbombs and hurtling comets! Defending your planet from invasion was never so challenging. Disruptor fire is your main defense against the fierce alien attacks.

16K Tape \$19.95 32K Disk \$24.95

### ORDERING



Customer service and product support call (612) 881-2777

Make checks or money orders payable to Nelson Software Systems. Personal checks allow 3 weeks. MAIL ORDERS: \$2.00 U.S. Shipping (\$4.00 CANADA \$10 OVERSEAS) Add \$2.00 for C.O.D.

**ORDERS SHIPPED SAME DAY!**



# RAINBOW SCOREBOARD

Give us your best: Join the ranks of these courageous CoCoists in showing the Color Computer world your high score at your favorite micro-diversion. We want to put your best effort on record in *the Rainbow's* Scoreboard column. All entries must be received by the first of the month to be eligible for the following month's Scoreboard.

Score	Player	Score	Player
<b>Astro Blast</b>			
63,000	★ Cameron Amick, Reisterstown, MD	10,249	★ Cameron Amick, Reisterstown, MD
53,000	Peter Niessen, Carlisle, MA	7,556	Peter Niessen, Carlisle, MA
<b>Avenger</b>			
11,560	★ Peter Niessen, Carlisle, MA	7,007	Eric D. Hemmert, Hasbrouck Heights, NJ
5,000	Cameron Amick, Reisterstown, MD	<b>Mega-Bug</b>	
<b>Bustout</b>			
25,510	★ Andy Klingler, San Diego, CA	6,211	★ Cameron Amick, Reisterstown, MD
<b>Color Haywire</b>			
10,250	★ Pat Downard, Louisville, KY	3,920	Peter Niessen, Carlisle, MA
9,750	Andy Klingler, San Diego, CA	<b>Pac-Attack</b>	
9,150	Cameron Amick, Reisterstown, MD	30,650	★ Peter Niessen, Carlisle, MA
<b>Color Invaders</b>			
83,000	★ Cameron Amick, Reisterstown, MD	<b>Pac-Droids</b>	
<b>Color Meteoroids</b>			
149,000	★ Cameron Amick, Reisterstown, MD	17,000	★ Peter Niessen, Carlisle, MA
<b>Color Scarfman</b>			
446,000	★ Andy Klingler, San Diego, CA	<b>Pacet Man</b>	
388,060	Michelle Thompson, Milpitas, MS	5,000	★ Cameron Amick, Reisterstown, MD
315,120	Kim Hansen, Ponoka, Alberta, Canada (Level 15)	<b>Polaris</b>	
<b>Colorpede</b>			
245,723	★ Cameron Amick, Reisterstown, MD	69,455	★ Alan Jay Weiss, Summit, NJ
<b>Colour Pac Attack</b>			
193,000	★ Cameron Amick, Reisterstown, MD	45,000	Andy Klingler, San Diego, CA
<b>Conquest Of Kzirgla</b>			
10,399	★ Scott Sehlhorst, Columbia, SC	36,000	Cameron Amick, Reisterstown, MD
<b>Donkey King</b>			
319,000	★ Steve Skrzyniarz, Tacoma, WA	30,500	Peter Niessen, Carlisle, MA
217,000	Eric Hemmert, Hasbrouck Heights, NJ	<b>Pop Corn</b>	
156,400	Andy Klingler, Sand Deigo, CA	110,570	★ Cameron Amick, Reisterstown, MD
115,600	Cameron Amick, Reisterstown, MD	<b>Protectors</b>	
98,000	Cameron Amick, Reisterstown, MD	358,514	★ Cameron Amick, Reisterstown, MD
<b>Doubleback</b>			
25,960	★ Mary H. Thomas, Louisville, KY	94,000	Gerry Schechter, Yonkers, NY
<b>Dunkey Munkey</b>			
1,099,400	★ Andrew Herron, High Point, NC	<b>Skiing</b>	
1,000,500	Wendy Johnson, San Jose, CA	1:04.17	★ Andy Klingler, San Digo, CA (No Errors)
626,400	Peter Niessen, Carlisle, MA	1:13.25	★ Cameron Amick, Reisterstown, MD
362,000	Chris Friend, Lake Elmo, MN	<b>Sky-Defense</b>	
311,500	Sara Hennessey, Golden Valley, MN	5,200	★ Cameron Amick, Reisterstown, MD
<b>Galactic Attack</b>			
31,780	★ Andy Klingler, San Diego, CA	<b>Space Assault</b>	
<b>Ghost Gobbler</b>			
825,250	★ Randy Gerber, Wilmette, IL	28,850	★ Cameron Amick, Reisterstown, MD
<b>Katerpillar Attack</b>			
<b>Space Invaders</b>			
<b>Space War</b>			
<b>Starfire</b>			
<b>Starship Chameleon</b>			
<b>Storm</b>			
<b>Venturer</b>			
1,526,200	★ Peter Niessen, Carlisle, MA	62,300	★ Peter Niessen, Carlisle, MA
313,250	David Glovinsky, Staten Island, NY	116,000	★ Peter Niessen, Carlisle, MA



# Print #-2,

We are really getting ready for RAINBOWfest as I write this month's column. What has been particularly gratifying is that a large number of you have written to say that you will be in attendance. I think I can say, without much qualification, that RAINBOWfest—particularly as a first-time enterprise—will be a success!

One of the things we said about the show a month ago comes up to be even more important now. That is the addition of a series of seminars and workshops for "CoCo's very first show." We wanted RAINBOWfest to be something more than just a trade show—and, thanks to the generous support of a number of people—it will be.

Don Inman has graciously consented to be the guest speaker at the breakfast Saturday morning. All of you are well acquainted with the remarkable expertise Don has brought in his columns in *the Rainbow* and the many books he has authored. I, for one, look forward to hearing him.

Aside from Don's talk, the breakfast will offer an opportunity for you to see more CoCo owners in one place than you ever have in your life! It has been set for the opening of the first full day of the show primarily as a get-together. I really hope you won't miss it!

I've talked in the past about "CoCo Community." The breakfast is one way we can all express that CoCo Community and break bread with one another. I'm really excited about it and hope to see many of you there.

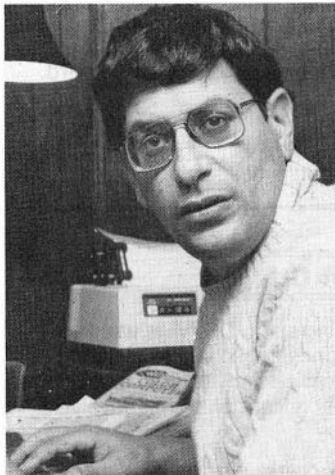

And, speaking of CoCo Community, I'd like to thank the members of the Northern Illinois Color Computer Club for volunteering to conduct the series of seminars we have planned on BASIC. This is taking a great deal of planning and coordinating. Thank you, NICCC!

One of our seminar leaders will be a new name to many of you, Tom Nelson. Tom is an attorney with the state of Minnesota, a principal in Nelson Software and our newest columnist. We welcome Tom and believe his commentaries on computers, software and the law under the heading *CoCo Counsel* will provide a significant contribution to the Color Computer world.

Others who will be talking include Chris Latham, who authored the nuclear power plant simulation which appears in this month's issue. He'll talk about machine language animation. Fred Scerbo of IMB, E. R. Bailey of Micro Logic and a number of others will also be on hand. We think these will be interesting sessions.

Of some major importance to Color Computer Clubs and User Groups is a meeting with me during RAINBOWfest. As you know, one of our major goals has been to support these groups, and we hope this meeting will provide us with some additional ways to be of help. If you are a member or an officer of a Color Computer Club or User Group, I hope you will make it your business to see someone is in attendance.

This officially announces the beginning of *the Rainbow's* first Simulation Contest. We've tried to provide a number of simulations in this month's issue to say you some idea of what this kind of program can be like. And, I am pleased to say we will have some excellent prizes—with the top prize a brand new Epson FX-80, 4K serial printer buffer and cable donated by JARB Software. Total value of this one prize alone is more than \$800. So, let's get those CoCo's working. We will announce more prizes later, but expect them to be well worth your valuable programming time.

The deadline for the contest is July 30. That is a change from what we announced in a preliminary way last month. All entries must be postmarked by July 30 to be eligible.

All entries become the property of Falsoft, Inc., and *the Rainbow*. Decision of the judges is final. Your simulation must be an original work—no "conversions"

(continued on Page 172)

**BETTER SOFTWARE COMPANY**  
P.O. Box 16842 — Sta. B  
Greenville, South Carolina 29606  
(803) 233-2700

PRESENTS



## COLOR-STICK

The ORIGINAL interface for  
the TRS-80\*  
Color Computer to let  
you use the famous:

## ATARI\* JOYSTICK

Just plug your Atari or Atari like joystick (the Color-Stick enables the use of most joysticks made for the Atari) into the Color-Stick interface and then plug the Color-Stick into an empty joystick port.

The Color-Stick can improve scores 50% and more while making some games more exciting and fun to play.

Don't settle for cheap imitations. Only the ORIGINAL Color-Stick's small inline design allows you to just plug your joystick into it and forget it. The Color-Stick becomes a part of your joystick so it does not interfere with your game playing. In addition Color-Stick returns a full value of '63' for the right and down directions, even when using two joysticks and even in the diagonal directions, the others don't.

NOW Color-Stick has a new low price.....

**Color-Stick interface \$12.95 each**  
**two for \$22.95 (less joysticks)**  
**Atari joysticks \$9.95 each**

**BETTER SOFTWARE COMPANY**  
P.O. Box 16842 — Sta. B  
Greenville, South Carolina 29606  
(803) 233-2700

Don't miss out order the ORIGINAL. Send your check or money order or better yet call today and order your Color-Stick.



Add \$2.00 per order shipping and handling. Bank cards welcomed (please include expiration date). Orders paid by cashiers check, money orders, bank cards and C.O.D. are shipped within 48 hours. Personal checks please allow 1-2 weeks. C.O.D. orders add \$1.50 extra. S.C. residents add 4% sales tax. \*TRS-80 is a registered trademark of Tandy Corp. Atari is a registered trademark of Atari, Inc.



# BUILDING A RAINBOW

The Simulation Issue . . .

The Bound-For-Chicago Edition . . .

The monthly storm before the Rainbow appears . . .

The Production Express, heading for Printer's Station . . .

**D**o all Civil War movies start out with the sound of a train whistle echoing through the station? And, as surely as the sweethearts are left behind, won't that steam engine soon be puffing black smoke and thundering 'round the bend just as we catch sight of the mile-high trestle? And, at the very last second before the tracks trade ground for the timber, doesn't somebody always go tumbling off the train and rolling down the bank?

I feel like I was pushed.

True enough, the momentum is enough to carry the Production Express across the wide chasm and on to Printer's Station, but what a time to jump off and count the cars! My heart is with those still on board as I watch the caboose disappear in the distance.

The analogy is a bit worn, perhaps, but putting together a magazine is a lot like forming a train. The cargo is produced sometimes months in advance. The bill of lading—we call it booking—takes weeks. A legal-sized clipboard serves as our switching yard, and, as on a mail train, a relentless pace is kept with only a breathless stop before still another train pulls out.

A lot of precious cargo missed the train this time. That's because, even with 244 pages, there's only so much room.

We do have a mighty trainload for you, though, this month. Dozens of articles. Dozens of programs. Who else offers so much in one issue just for the Color Computer?

From the creative genius of many "big name" contributing editors to the enjoyable home style writing of our *Rainbow* reviewers, we truly believe there's something for everyone, and some things for everybody. We hope you agree.

This is our simulation issue. Along with announcing our simulation contest—we already have two entries—we have two solid examples of simulations to show you how it's done. More simulations will appear in next month's *Rainbow*, too.

May I recommend a book? *Stimulating Simulations* by C.W. Engle is an excellent introduction to the art of creating and developing simulations. It's published by Hayden Book Co. as part of their microcomputer series.

By the way, if you think this month's nuclear power simulation isn't your

thing, let me point out that one of its co-creators is also the author of *The King* for Tom Mix Software. I know Dr. Doom loves meltdown-a-minute action.

Ms. Doom, on the other hand, is already addicted to *Color Poker*, a creation of Joseph Kohn's that is a delight to play.

New this month is our *CoCo Counsel* department, featuring Tom Nelson of Nelson Software. If you are marketing software, or planning to, check out his first column this month. Tom will be with us in Chicago, too, to hold a special seminar at *RAINBOWfest*.

Also new this month is our *Received & Certified*, which spotlights new product arrivals at *the Rainbow*.

New, too, is our tear-out card to order magazine subscriptions, renewals and *Rainbow On Tape*. That brings me to a final word: An invitation.

If you aren't among those who have a year 'round pass to *the Rainbow's* trainload of top-flight articles and programs, I hope you'll pull out that subscription card and climb aboard.

—Jim Reed

## FILMASTR

A powerful DATA MANAGEMENT SYSTEM for the COLOR COMPUTER. If you have been wanting a really good data manager at a reasonable price, **THIS IS IT!** FILMASTR combines the best features of the big systems to provide a combination of speed, power, and simplicity that can't be beat.

**CUSTOM SCREENS** - Design input screens with up to 20 fields. Inverse labels for contrast.

**FORM FILL ENTRY** - Non-destructive blinking cursor, full screen editing, no garbage collections, copy fields from previous record. Keeps up with the fastest typist.

**FAST SORT & SEARCH** - Machine language sorts the entire file in seconds. Sort on any field or fields. Use a variety of relational search techniques to select any record or group of records that you can define.

**EDIT FILES** - Change or delete any record easily. Create and save sub-files or append files.

**PRINT FORMAT** - Print any field in any order on any line. Insert characters or phrases.

**MENU DRIVEN** - No special commands to be learned. All functions are menu selected and aided by on screen instructions.

**CAPACITY** - Up to 255 characters per record, 24000 characters per file. (9000 with 16K)

**DOCUMENTATION** - A thorough manual with examples and explanation of every command.

**FILMASTR** 16K or 32K ..... TAPE \$29.95  
EXT BASIC ..... DISC 34.95

## TIME & MONEY

A "WHAT IF?" financial planning tool. T & M is used to evaluate the time value of money as an aid in planning investments, savings plans, retirement plans, leases, loans, mortgages or any other situations that involve compound interest.

The program is menu driven with simple on-screen instructions. It uses a unique form fill-in for data entry with easy editing. It even accepts simple math expressions as input.

Calculated results are automatically entered as data and can be used for further "WHAT IF?" calculation. All factors are always on screen, making it easy to understand the relationship between **TIME & MONEY**.

### TIME & MONEY

16K or 32K ..... TAPE \$19.95  
EXT BASIC ..... DISC 24.95

THE  
COMPUTER  
HOUSE

(814) 371-4658

**BOX 1051, DUBOIS PA, 15801**



Add \$2.00 Postage & Handling  
PA Residents Add 6% Tax  
C.O.D. \$2.00 Additional



# Celebrate RainbowFest!

## COLOR SCRIPSIT™, TELEWRITER™, TELEWRITER 64™ TEXT PRO AND TEXT PRO II™ OWNERS CELEBRATE THE RAINBOWFEST WITH THIS LIMITED OFFER!

The RainbowFest is a time for celebration. We want to help you celebrate by offering you a wonderful opportunity to enter the totally integrated and compatible world of the **Super "Color" Library**. Nelson Software Systems has put it all together, all the programs you'll need to solve your problems, with all the features you have grown to like, including eight lowercase screen displays **WITH DESCENDERS**. You also get the elegance, professional quality, power, flexibility and ease of use you have come to expect from Nelson Software Systems products. We want to give you an opportunity to trade up to quality. Make the RainbowFest a real time for celebration - trade your word processor in for the undisputed best, the **Super "Color" Writer II Version 3.0**, and begin to build your **Library** of essential software!

All you have to do is send us your Color Scripsit, Telewriter, Telewriter 64, Text Pro or Text Pro II program and receive your **FULL PURCHASE PRICE** (up to \$59.95) as credit toward the purchase of the brand new gold embossed leatherette bound Version 3.0 64K compatible **Super "Color" Writer II!**

Just fill out and sign the coupon below and send it, together with your ORIGINAL program and manual plus proof of purchase (receipt, registration card, etc.), the price difference and \$3 for shipping and handling, and we'll send you the NEW **Super "Color" Writer II Version 3.0**. For example, if you wish to trade in your Color Scripsit disk for the **Super "Color" Writer II** disk, just send in the coupon, program, manual and proof of purchase, plus the price difference, \$40, and \$3 for shipping and handling for a total of \$43.

This limited offer is only good through May 15, 1983. Act today! We guarantee same day return shipment.

COUPON



I want to sign up for my new Super "Color" Library card now. Enclosed are my original \_\_\_\_\_ program and manual, proof of purchase, and money order or credit card order in exchange for my copy of the NEW Super "Color" Writer II Version 3.0.

NAME \_\_\_\_\_

ADDRESS \_\_\_\_\_

CITY, STATE & ZIP \_\_\_\_\_

Visa # \_\_\_\_\_ Exp. Date \_\_\_\_\_ MasterCard # \_\_\_\_\_

Signature \_\_\_\_\_

**NELSON™  
SOFTWARE  
SYSTEMS** 

A Division of Sofllaw Corporation

9072 Lyndale Avenue So. 612/881-2777  
Minneapolis, Minnesota 55420 U. S. A.

- \* Disk owners may not trade for rompak or tape versions.
- \* Personal checks allow three weeks for delivery.
- \* Limited to one trade-in per person.

No C.O.D. accepted.

Color Scripsit is a trademark of Tandy Corp.  
Telewriter and Telewriter 64 are trademarks of Cognitec.  
Text Pro and Text Pro II are trademarks of Cer-Comp.



## Here's A Flashy Little Program, By Thunder

By John Plaxton

The following program, *Lightning*, continually generates a single flash of forked lightning across a PMODE4 screen. Each flash is different.

The program is part of a father-son effort in generating an electronic window display of numerous scenes suitable for Halloween.

You may be interested in trying to devise a suitable program for thunder.

The listing:

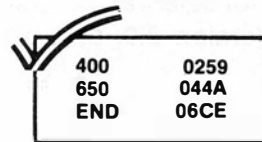

```

10 '          L
20 '          I
30 '          G
40 '          H
50 '          T
60 '          N N
70 '          I I
80 '          N N
90 '          G G
100 '
110 'define variables, display
120 DIM X(14),X1(14),Y(14),Y1(14)
130 PMODE4,1
140 PCLS
150 SCREEN1,1
200 'generate initial position
210 X(0)=150+RND(75)*(((RND(2)>1)
)*2)+1)
220 Y(0)=0
230 X1(0)=X(0):Y1(0)=0
240 LINE(X,Y)-(X,Y),PRESET
300 'generate single bolt portio
n
310 FOR T=1TO RND(13)
320 X(T)=X(T-1)+RND(15)*(((RND(2)
)>1)*2)+1)
330 IF X(T)<0THEN X(T)=0
340 X1(T)=X(T)
350 Y(T)=Y(T-1)+RND(10)
360 Y1(T)=Y(T)
370 NEXT T
400 'generate forked portion
410 FOR T=T TO 13
420 X(T)=X(T-1)+RND(10)*(((RND(2)
)>1)*2)+1)
430 IF X(T)<0THEN X(T)=0

```

```

440 X1(T)=X1(T-1)+RND(10)*(((RND
(2)>1)*2)+1)
450 IF X1(T)<0THEN X1(T)=0
460 Y(T)=Y(T-1)+RND(10)
470 Y1(T)=Y1(T-1)+RND(10)
480 NEXT T
500 'display lightning flash
510 FOR T=1TO13
520 LINE(X(T-1),Y(T-1))-(X(T),Y(
T)),PSET
530 LINE(X1(T-1),Y1(T-1))-(X1(T)
,Y1(T)),PSET
540 NEXT T
550 FOR S=0TO50:NEXT S
600 'remove lightning from sky
610 '
620 PCLS'use this if nothing
else is on screen, else delete
630 '
640 FOR T=1TO13
650 LINE(X(T-1),Y(T-1))-(X(T),Y(
T)),PRESET
660 LINE(X1(T-1),Y1(T-1))-(X1(T)
,Y1(T)),PRESET
670 NEXT T
680 GOTO200
1000 '
1010 '
1020 'The lightning is generated
in two arrays, one for eac
of two forks,
1030 'Fourteen co-ordintaes are
generated,X and Y being
independent of each other.
1040 'The distance between point
s
is randomly generated.
the horizontal values can
be + or -, but the vertica
values are always +.
1050 'Initially, a random number
of points are duplicated i
both arrays to give the
impression of a single
lightning bolt.
1060 'Then, points for each arra
y
are generated to produce
forked lightning.

```





The Official

# ZAXXON™

by SEGA®

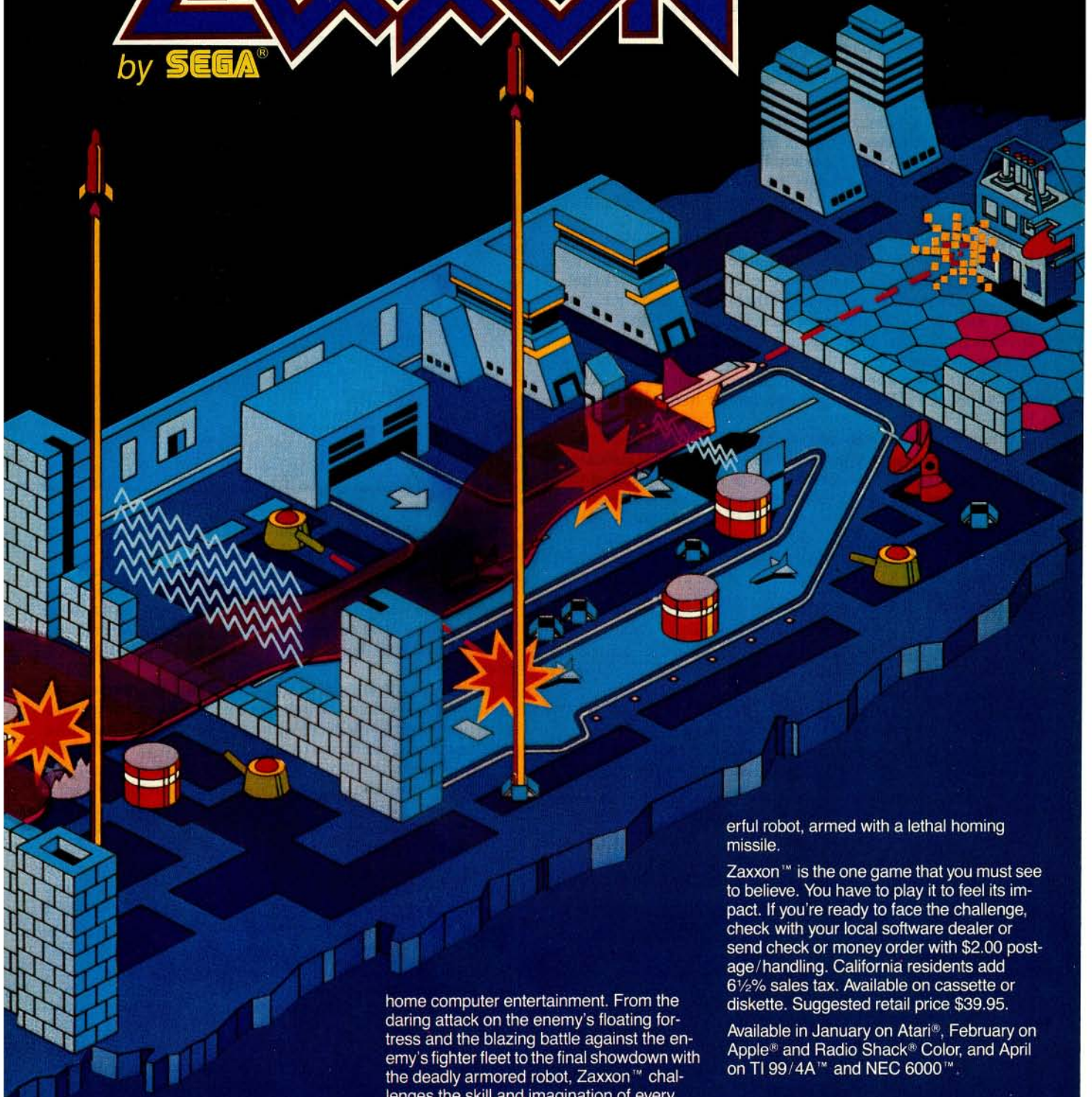

The game that puts space games in perspective. Zaxxon™, one of the most popular arcade games of 1982, is now available for use with your home computer system.

Zaxxon™ technology and creativity present a 3-dimensional-like playfield which sets Zaxxon™ apart from other computer games.

Zaxxon™ looks and sounds like aircraft flight, and players can soar to new levels of

home computer entertainment. From the daring attack on the enemy's floating fortress and the blazing battle against the enemy's fighter fleet to the final showdown with the deadly armored robot, Zaxxon™ challenges the skill and imagination of every player at every level of skill.

Imagine yourself the pilot, attacking the enemy fortress—climbing, diving, strafing to score points and extra fuel. The enemy fights back with a barrage of missiles and gunfire. Then you face a fleet of enemy fighters in a gripping dogfight of altitude strategy and flying skill. Survive this battle and the enemy's fortress, defended with laser barriers, then you've earned the ultimate challenge; a blazing confrontation with the pow-

erful robot, armed with a lethal homing missile.

Zaxxon™ is the one game that you must see to believe. You have to play it to feel its impact. If you're ready to face the challenge, check with your local software dealer or send check or money order with \$2.00 postage/handling. California residents add 6½% sales tax. Available on cassette or diskette. Suggested retail price \$39.95.

Available in January on Atari®, February on Apple® and Radio Shack® Color, and April on TI 99/4A™ and NEC 6000™.

**Datasoft Inc.®**  
COMPUTER SOFTWARE

9421 Winnetka Avenue  
Chatsworth, CA 91311  
(213) 701-5161  
©1982 Datasoft® Inc.

Datasoft® is a registered trademark of Datasoft Inc.®

Sega® and Zaxxon™ are registered trademarks of Sega Enterprises Inc.



## HARDWARE

### Install a Chip-Saving 'Power On' Light

By William C. Clements, Jr.

The Color Computer has a lot of nifty features, but one that it doesn't have is a power-on indicator. Sure, the presence of the green screen on the attached TV will signal you whether the computer switch is turned on, but what if you turn off the TV and forget the computer is on too? That AC switch is hidden on the back, out of the way and out of sight, and it's easy to forget it.

We have seven Color Computers in a student facility here in Chemical and Metallurgical Engineering at the University of Alabama, and the students were forever doing just that. We have the dust covers on all of them, and believe me, you don't want to go off and leave an 80C on overnight with the cover in place. That power transformer gets hot enough even when it has plenty of ventilation, and the SAM chip and the memory ICs get warm under their metal shield, too. After that happened a few times, I decided we had to have pilot lights.

I have noticed one commercial device to solve this problem. It provides a light-emitting diode (LED) indicator lamp mounted in a device that plugs into a joystick port, getting power off the +5 volt line provided there. However, it's easy (and much cheaper) to do the job right and install a first-class pilot lamp inside the case, where it belongs.

Radio Shack sells a pack of two LED indicators (Stock No. 276-018) for \$1.79. These lamps come in a neat snap-in

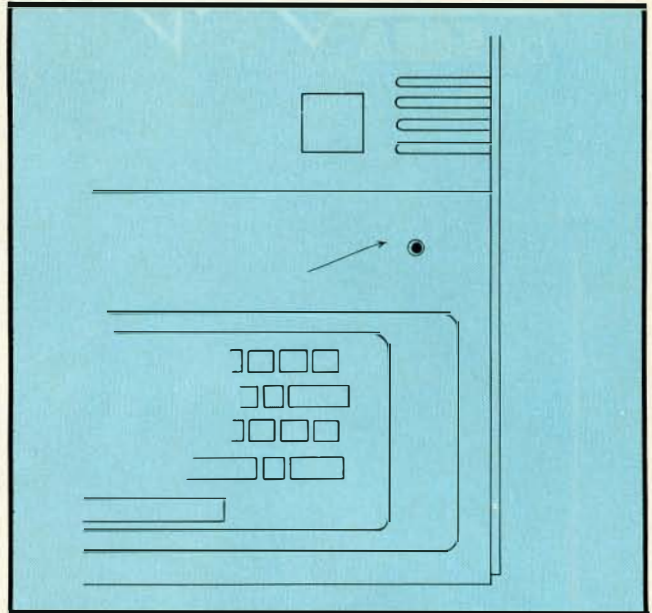

housing that requires only a 5/16 inch hole and a little finger pressure to produce an installation that looks just as good as if it came that way from the factory.

You can mount the lamp where you like; I put ours just above the right edge of the keyboard, as shown in Figure 1. Unplug your computer and turn it upside down onto a towel or other protective surface. Remove the seven screws that hold the case together, turn it back over, and lift off the top cover.

Make a small dimple in the plastic case by pressing the point of a nail where the light is to go, then carefully drill a 5/16 inch (8mm) hole there with an electric drill. Start with a small hole and work up to the full size, to keep the hole round. Push in the lamp from the top of the case, making sure it goes in all the way and snaps securely in place. Solder a 1000 ohm, 1/4-watt resistor to the longer (positive) lamp lead.

Cut two pieces of insulated flexible wire (I used wire-wrap wire here), each about a foot long, and twist the wires together. Solder one wire to the free end of the resistor and the other wire to the remaining lead of the lamp. Push pieces of insulating tubing over each wire and slide them up next to the lamp casing, pushing over wire, resistor, and all, to cover all exposed metal.

For circuit boards through Revision E, connect the wire from the resistor to the circuit-board wire-wrap pin labeled TP9, which is the +12 volt point, and the other wire to TP4, which is ground. If you have the newest revision of the circuit board (the one with the power transformer mounted on the board and having the small tab-mounted RF shield), the +12v. point is the pad labeled TP3, and ground is the pad labeled TP2.

Reassemble the case, taking care that the wires don't get pinched anywhere, and you have it done. The whole job takes about 20 minutes and costs a total of two dollars, and for that price you even have a spare lamp left over to use for something else. Now you have no excuse for going off and leaving the power on to fry your SAM chip or those brand-new 64K memory upgrades!



The **Micro Catalog**

DISCOUNT HARDWARE & SOFTWARE

"TAKE ADVANTAGE OF VOLUME BUYING"

- Some software houses offer up to 50% off for volume buying.
- We are dealers for over one hundred different software houses.
- We market over one thousand different programs.
- CONFIDENTIAL price list.
- NEWSLETTER
- SPECIAL BUYS
- 150 Page CATALOG
- Authors we pay 50%

**NEW!**



Please send \$9.95 for CATALOG  
and CONFIDENTIAL PRICE LIST

P. O. Box 3703 Peoria, Il. 61614





**TDP SYSTEM 100\* / QUALITY DISCOUNT PRODUCTS / COLOR COMPUTER\*  
DISCOUNT PRICES / COMPARE / WE'RE FAST / ORDERS SHIPPED WITHIN 24 HR.**

**Software Specials 20% OFF**

**PRICKLY-PEAR SOFTWARE**

Flight	19.95	15.95
Magic	19.95	15.95

**COMPUTEWARE**

Doodle Bug	24.95	19.95
Pac Tac	24.95	19.95
Rail Runner	21.95	17.55
Storm	24.95	19.95

**TOM MIX SOFTWARE**

Donkey King	24.95	19.95
Katerpillar	24.95	19.95
Protectors	24.95	19.95

**MARK DATA PRODUCTS**

Astro Blast	24.95	19.95
Space Raiders	24.95	19.95

(Limited quantity. Call for availability)



**PRICKLY-PEAR SOFTWARE 15% OFF ALL LIST**

Viking*	19.95	16.95	Astrology*	34.95	29.95
Gangbuster	19.95	16.95	Great Word Game*	19.95	16.95
Football	19.95	16.95	Household Helper	19.95	16.95
I Ching	19.95	16.95	Math Pack 1	19.95	16.95
Numerology	19.95	16.95	Pre-Read	24.95	21.95
Tarot	19.95	16.95	Song Book (w/tapes)	29.95	25.95
Trilogy (I Ching, Numerology, Tarot)	39.95	33.95	Fantasy Games Pk	19.95	16.95
Phonics I	24.95	21.95	Fantasy Games Pk 32k	24.95	21.95
8-Bit Bartender	19.95	16.95	Phonics II	24.95	21.95
			Las Vegas Weekend	24.95	21.95

**TDP -**

16K Extended	449.95
Disk Drive 0	485.00
Line Printer 1 (DMP 100)	389.00
Cassette Tape Recorder	59.95
Verbatim Dist (Pk of 10)	31.99
Computer Cassettes	.99
64K RAMS	63.95
14 1/2" Tractor Feed (White)	34.95
9 1/2" Tractor Feed (White)	24.95
Assorted ROM Packs	10% OFF

(Call for prices)

**Computer Island**

Circus	10.00
School Maze	10.00
Name That Song (I, II, III)	10.00 each

**4K**

Silly Sentences	6.00
Silly Stories	6.00
Poetry	6.00
Wizard	6.00
Apartment House	
Mystery	6.00

**Eigen Systems**

Basic Aid (cart.)	34.95
Stripper	7.95
Ccead	6.95

**B5 Company**

Clock	24.95
Money	19.95
Math Fact	16.95
ABC's	9.95

**Sugar Software**

Silly Syntax	19.95
Additional S.S. Tapes:	9.95
Fairy Tales	
Sing Along	
X-Rated	
Current Events	
Adventure	
Potpourri	
Auto Run	14.95
TIMS (32K)	24.95

**Spectrul Associates**

Cosmic Invaders	21.95	19.75
Meteorites	21.95	19.75
Space Wars	21.95	19.75
Ghost Gobbler	21.95	19.75
Robot Attack	21.95	19.75
Galax Attack	21.95	19.75

**Petrocc Freelance Associates**

Inspector CLUEseau	19.95	17.95
Stress	19.95	17.95
Weather Watch	19.95	17.95

**Aardvark Products**

Haunted House	9.95
Killer Bot	13.95
Labyrinth	14.95
Starship Herc.	14.95
Time Trek	14.95
Escape from Mars	14.95
Pyramid	14.95
Quest	14.95
Trek Adventure	14.95
Circle World	14.95
Nuclear Sub	14.95
Venture	19.95
Tiny Compiler	24.95
Tube Frenzy	19.95
Derelict	14.95
Caterpillar	19.95
Space Battler	12.95
Golf	9.95
Catchem	19.95

**Terms:** Cash, money order, your personal checks welcome. No waiting to clear on software items. Shipping - \$2.50 for software, 3% for hardware. C.O.D. please add 3% for hardware. Arizona resident please add 4% sales tax. All program - 16K Ext. We reserve the right to change prices without notice.

**Warranty:** All hardware products are warranted for a period of 180 days from date of purchase. We shall not be liable for loss or damage, alleged or caused indirectly to hardware or software including interruption of service, business loss, loss of expected profits or any damage resulting from use of hardware or software.

**Desert Software, P.O. Box 502, Cortaro, AZ 85230  
(602) 744-1252**



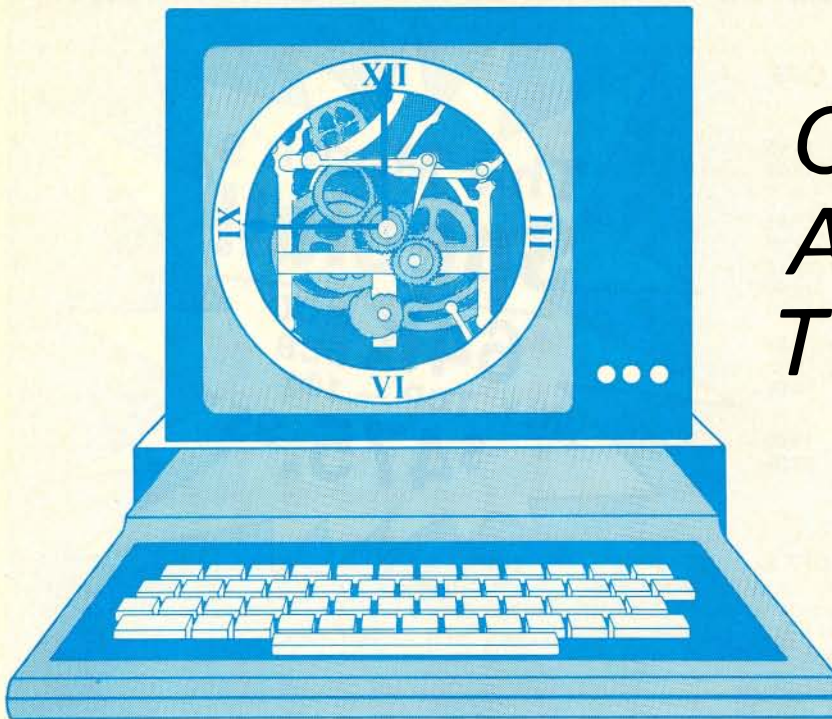

# CoCo Clock An Accurate Timepiece

By A.B. Trevor  
(70000, 130)

One of the advantages in having your own computer is that you can have it *do* things for you, even when you are not sitting in front of it. Of course, your computer must perform these tasks on schedule. But how can your CoCo keep accurate track of time? Its internal time bases are less than one percent accurate—unsuitable for long-term time keeping. At least one manufacturer (Basic Technology) has attempted to solve this problem, but the solution costs more than a CoCo (\$379 for a BT-1000 and BT-1020 Clock). Fortunately, a very accurate time base can be obtained for less than \$40 from Radio Shack's Plug 'n Power (TM) Remote Controller (Cat. #26-1182). Even if you have no interest in controlling lights and appliances (which this little box does very well), the P 'n P may be a suitable real time clock for your application.

Last month, we looked at the P 'n P hardware and a BASIC program for controlling lights. This month, we shall discuss how to use the P 'n P as a time base in a simple BASIC program (Listing 1) that calls some interesting machine language subroutines. (The sources of these routines are too lengthy to be reproduced here, but are available to *Rainbow* subscribers on CompuServe). There are some limitations to this implementation, so before examining the programs in detail, let's consider some of the problems in implementing an accurate clock in the Color BASIC environment.

As any serious student of CoCo anatomy knows, the 6809 is equipped with three hardware interrupts: the nonmaskable interrupts (NMI), the fast interrupts request (FIRQ), and the normal interrupt request (IRQ). In our favorite machine, the NMI is usable only by cartridges that are so inclined (like the Disk Controller), and the FIRQ is used (wasted?) for detecting the presence of a cartridge. The IRQ, however, can be connected to either one of two

"clocks" under program control and used to time events without tying up the whole processor.

Of the two IRQ clocks, the horizontal sync clock (HS) occurs too often (every 63.5 microseconds) to be efficient in a time-of-day clock application. The field sync clock (FS) interrupts every 16.667 milliseconds, so it is the preferred choice for most timing jobs. FS is used by Color BASIC for the SOUND duration, and by ECB for the TIMER function. If you have played with TIMER at all, then you already know why the FS is very limited as a real time clock: it is not exactly 1/60th of a second, and has no long-term accuracy.

The Plug 'n Power controller provides a partial answer. As mentioned in my February article, this device contains a power line frequency detector. Each time the 60 Hz power signal is accurate over the long term. Unfortunately, the clock line is connected to the cassette data input, which cannot cause an interrupt in an unmodified machine. An interrupt is tantalizingly available on the RS-232 status line, but if we modified the Plug 'n Power to use the RS-232 port, then where would our printer or modem go? So, with no interrupt available, the CPU must spend a good percentage of the time just watching the cassette data input to maintain an accurate time base using the P 'n P. Well, the solution below is not ideal, but involves no hardware changes.

## Dual Time Base

The first time you set the time of day with the *USRI* function (Listing 1), two changes to the BASIC environment are made: 1) a new IRQ service routine is inserted, and 2) BASIC's keyboard-input-wait routine is modified to count pulses from the P 'n P box. If your BASIC main program is executing (or if the P 'n P is off or disconnected), then time is maintained by means of the FS interrupt. Whenever your

BASIC program is not running or is waiting for input from the keyboard, then accurate time keeping with the P 'n P controller is in effect. Accurate time can also be maintained if your program calls *USR2* to wait for a specified time of day. Since most control programs will spend most of the time waiting for keyboard input or for some specific time, little accuracy will be lost by this "dual time base" technique. Considerable time will be lost if your program invokes BASIC functions that turn off the IRQ—notable I/O. Cassette I/O totally shuts down both time bases for the entire transfer period, while disk usually causes the loss of only a few seconds. In any case, this clock is very accurate for many applications, and it is easy to test its accuracy in your own programs, since the time is continuously displayed in the upper right of BASIC's text page.

A magenta colored, non-blinking cursor is used to signal that P 'n P timing is in effect. If you see BASIC's familiar multi-color cursor after running the program, then the P 'n P is not properly connected or is not switched to "CTRL."

### Program Description

Listing 1 is a simple BASIC program that loads the clock routines, initializes them, and sets the day and time from your inputs. Once you run it, the day of the week and the time of day will appear continuously in the upper right of the text screen. Be sure that your P 'n P is switched to "CTRL" for maximum accuracy. You can load and run most BASIC programs without destroying the clock.

Two "USR" functions are the heart of the program. *USR0* sets the day of the week from an integer argument (1 = Sunday, 2 = Monday, ...). *USR1* sets the hour from the high order 8 bits and the minute from the low order 8 bits of the argument. The current day or time can be read by calling with a negative argument. Note that *USR1* returns the time as four BCD digits, which is not the same format used to set time. Once the clock has been set, time is maintained by calls to the machine language TICCLK routine either from the IRQ service routine (IRQULK) or from NEWHK. NEWHK turns off the IRQ clock and sets the cursor to \$EF (magenta block). It then loops, looking for pulses on the cassette input line (bit 0 in BSRSTA) or for a key. TICCLK is called once for each pulse seen. If no pulses are seen in a reasonable time, or if a key depression is noticed, the IRQ clock is reenabled and control is returned to BASIC.

A third user callable routine, *USR2*, (not called by this BASIC program), is used to wait for a particular time. It returns with a zero value when the specified time is reached, or with the value of an ASCII character if a key was depressed before the time was reached. If the P 'n P is not turned on, *USR2* returns -1.

The machine language routines are written in position independent code, so may be relocated anywhere in memory. For example, 16K machine owners will want to delete line 80 of Listing 1 and remove the first apostrophe in line 90 to keep the routines within 16K.

All of these routines are used by the full function home control program to be presented in a later article in this series. Once again, this month's programs can be downloaded from ComPuServe. Type "R ACCESS" from the PROgrammer's area, then "DOW PNPCLK.CC 70000,130" for the BASIC program, or "COPY X10CLK.M69 [70000,130]" for the assembly language sources in MAC69 format. Some changes will be required for less powerful assemblers such as EDTASM+.

*(Alexander B. Trevor is Executive Vice President for Computer Resources at CompuServe.)*

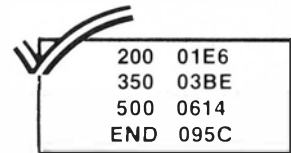

```

200 01E6
350 03BE
500 0614
END 095C

```

The listing:

```

10 '*****
20 ' P'N'P REAL TIME CLOCK
30 '
40 ' (C) A.B. Trevor 1983
50 '
60 '*****
70 '
80 CLEAR 100,&H7D00:' FOR 32K
90 'CLEAR 100,&H3D00:' FOR 16K
100 ML=PEEK(39)*256+PEEK(40)+1
110 DEFUSR0=ML: DEFUSR1=ML+3: DE
FUSR2=ML+6
115 IF PEEK(ML+445)=127 AND PEEK
(ML+2)=145 THEN 200
120 '
130 'READ IN THE M/L CLOCK
140 CLS: PRINT@138,"LOADING M/L"
150 FOR I=ML TO ML+445
160 READ A: POKE I,A: NEXT I
170 CLS
180 '
190 'SET THE DAY AND TIME
200 INPUT"DAY OF THE WEEK";A$
210 DAY=(INSTR(1,"SUMOTUWETHFRSA
",LEFT$(A$,2))+1)/2
220 X=USR0(DAY)

```

## COLORTERM I.I

**NOW!** DISK COMPATIBLE VERSION AND  
NEW FEATURES INCLUDED —  
NO PRICE INCREASE

The Color Computer\* as an intelligent terminal  
with 51 or 64 columns by 21 lines  
plus true lowercase! All done in software.

Any data format — 16K or 32K — 300 or 110 Baud  
Print and save host data to cassette  
Encode data for secure storage   
User programmable keys

**Much more!**

- reverse video
- partial screen clear
- 4-way cursor control
- automatic repeat when key is held down
- enter data offline for later uploading to host
- macro buffers for often-used output
- patch the 51 or 64 column display to your own basic and assembly programs
- preserve a "window" of any size, new material scrolls through remainder of screen

"...Very impressed..." — The Rainbow  
"...Very pleased...high marks..." — Color Computer News  
"...Easy to use...text densities are high enough to allow doing some serious work." — 80 Micro

Cassette and disk versions included with all orders  
add \$5.00 if you want programs on a disk

**\$34.95 (U.S.) \$40.95 (Canadian)**  
M.O., VISA, M/C (include expiry)

**MARTIN CONSULTING, 94 Macalester Bay  
Winnipeg, Man. R3T 2X5 CANADA**

\*T.M. of Tandy Corp.



```

230 INPUT "HOUR:MIN";HR,MIN
240 X=USR1 (HR*256+MIN)
250 END
260 '
270 DATA 22,0,145,22,0,159,22,1,
9,22
280 DATA 1,178,79,106,141,0,32,4
6,100,48
290 DATA 141,0,26,134,120,167,13
2,166,130,45
300 DATA 88,139,1,25,167,132,161
,6,45,28
310 DATA 111,132,32,239,255,255,
255,255,255,0
320 DATA 0,7,36,96,96,0,255,0,25
5,0
330 DATA 106,140,242,141,203,110
,156,243,230,140
340 DATA 230,88,88,48,141,0,39,5
8,198,4
350 DATA 206,4,20,189,165,154,48
,140,213,141
360 DATA 10,134,58,167,192,141,4
,134,58,167
370 DATA 192,166,132,68,68,68,68
,138,48,167
380 DATA 192,166,128,132,15,138,
48,167,192,57
390 DATA 19,21,14,32,13,15,14,32
,20,21
400 DATA 5,32,23,5,4,32,20,8,18,
32
410 DATA 6,18,9,32,19,1,20,32,18

```

```

9,179
420 DATA 237,77,45,3,231,140,144
,79,230,140
430 DATA 140,189,180,244,57,140,
32,55,190,255
440 DATA 248,238,1,239,140,135,5
1,140,137,239
450 DATA 1,52,2,182,255,3,138,1,
183,255
460 DATA 3,206,1,106,166,196,174
,65,167,141
470 DATA 255,111,175,141,255,108
,134,126,48,141
480 DATA 0,148,167,196,175,65,13
4,18,167,140
490 DATA 200,53,2,189,179,237,77
,45,22,52
500 DATA 4,141,26,231,141,255,65
,53,2,141
510 DATA 18,231,141,255,58,111,1
41,255,55,28
520 DATA 239,236,141,255,47,189,
180,244,57,95
530 DATA 140,203,16,128,10,44,25
0,139,10,52
540 DATA 2,234,224,57,189,179,23
7,52,4,141
550 DATA 234,231,141,0,60,53,2,1
41,226,231
560 DATA 141,0,53,26,16,182,255,
32,133,1
570 DATA 38,249,142,7,208,48,31,
39,44,182
580 DATA 255,32,133,1,39,245,23,
254,205,236
590 DATA 141,254,235,16,163,141,
0,17,39,17
600 DATA 173,159,160,0,39,215,31
,137,79,189
610 DATA 180,244,28,239,57,0,255
,79,95,189
620 DATA 180,244,57,204,255,255,
189,180,244,57
630 DATA 50,98,23,254,204,15,112
,13,111,16
640 DATA 38,0,70,52,20,174,141,2
54,188,191
650 DATA 1,13,134,239,167,159,0,
136,182,255
660 DATA 32,133,1,38,249,142,7,2
08,48,31
670 DATA 39,31,182,255,32,133,1,
39,245,23
680 DATA 254,112,173,159,160,0,3
9,226,198,96
690 DATA 231,159,0,136,48,141,25
4,144,191,1
700 DATA 13,53,148,48,141,254,13
5,191,1,13
710 DATA 126,161,179,126,161,127

```

### Y-PAK Dual Slot Expander for Radio Shack's Color Computer

Have your Disk and Cartridge too!  
Select between 2 Cartridge slots with one  
switch and control the Auto Start with  
the other switch.

\$70.00 Complete

### USER-PAK for Color Computer

Your own RAM/EPROM Cartridge  
Cartridge holds two 2732s, or any combination  
of four 2716s/6116s.

\$30.00 less RAM/EPROM  
\$90.00 with 8K RAM

EPROMs burned from your CC cassette.  
Write for details.

**B. Erickson**

P.O. Box 11099 Dept. RB  
Chicago, IL 60611

# DO YOU HAVE A BASIC OR ASSEMBLY PROGRAM TO SELL?

## ... avoid unreliable cassette tapes and recorders and EPROM your program!

With EPACK, BASIC and assembly routines for color computer can be read from cassette tape and stored onto 2516, 2716 (single supply), 2732, 2532, 2564 and 2764 styled EPROM (21 and 25 volt) These EPROM are then inserted into MMB, a game packlike cartridge that automatically executes your program when it's inserted into the color computer ... just like the game packs

EPACK is an excellent alternative to cassettes for programs you want to sell and for personal programs you would like to execute quickly and conveniently from a more reliable medium.

NOTE: 2732, 2764 and 21 volt capability are available optionally and are **not included** in the standard EPACK. \*\*

**EPACK consists of EPG, BROM and MMB for ..... \$150.00**

The units in EPACK are sold individually as follows:

### BROM

Utility fits any memory size color computer. Its function is to process BASIC source files into a format that can be written out to EPROM by Control Craft Inc.'s EPROM programmer (EPG) ... and still be executed by the BASIC interpreter - but from EPROM, not RAM!

**BROM ..... \$25.00**

### EPROM PROGRAMMER (EPG)

- Zero insertion force socket
- Personality plugs configure programmer to accept 2716 (5 volt supply), 2532 and 2564 style EPROM.
- Programmer's software is included on the programmer board as firmware.
- Program sources:
  - \* read cassette tape files into memory and then write file to EPROM (files are in Radio Shack format)
  - \* write color computer RAM to EPROM
  - \* read EPROM inserted in programmer into RAM
  - \* write color computer ROM to EPROM
- Functions:
  - \* test EPROM to see if it's unprogrammed
  - \* read an EPROM into color computer RAM
  - \* write RAM buffer out to EPROM
  - \* redefine the location of the RAM buffer
  - \* verify the programming of an EPROM
  - \* compare the contents of RAM buffer against an EPROM
  - \* edit the RAM buffer
    1. Examine/change memory locations
    2. Examine/change start buffer address
    3. Fill RAM buffer with FF hex
  - \* read blocks from a cassette file into RAM
- Menu driven operation allows easy use
- Plastic case enclosed circuitry
- Gold plated edge connectors
- Self-contained unit ... no external power supplies are used
- Unit operates on any memory sized TRS-80 color computer.

**EPG ..... \$105.00**

### MULTI MEMORY BOARD (MMB)

- Complete with support IC, sockets and decoupling capacitors
- Accepts 2516, 2716, 2532, 2732, 2564 EPROM (included in EPACK)
- Accepts 2016, 4016, 6116 static RAM\*
- Max capacity of 6 memory chips
- Runs on any size TRS-80 color computer
- Board is jumper addressable to either \$C000 or \$8000
- Provisions for write protect switch, or can jumper the board to write protect RAM

- Jumpers configure the memory type used on the board. Provisions for inserting DIP switches in place of the jumpers
- Gold plated edge connector
- Each IC or IC socket has decoupling cap installed
- Plastic case is available extra, at \$7.50 (pricing is subject to change without notice) (case included in EPACK)

\* RAM may not work with series E or later color computers.

**MMB ..... \$30.00**

<b>** UPGRADE</b> (optional for EPACK or EPG)	
2732-25 volt .....	<b>\$15.00</b>
2732-21 volt .....	<b>\$15.00</b>
2764-25 volt .....	<b>\$15.00</b>
2764-21 volt .....	<b>\$15.00</b>

### SDUMP

OKIDATA owners know that in order to print graphics they lose their serial interface ...

**NOT ANY MORE!**

Now you can print Hi-res Pmode 4 graphics images, full size and detail, on your OKIDATA, EPSON and other printers, without dot addressable capacity.

Features:

- Callable from BASIC routine
- Runs stand alone with a menu
- Relocatable
- Automatically finds the start of graphics pages
- Configurable for several printers
- Fast
- Useable on 16 or 32 or 64 K machines with or without Extended BASIC
- Documented

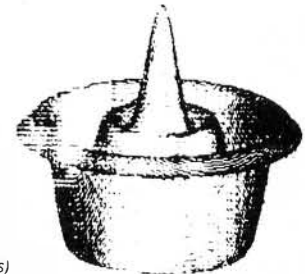

(OKIDATA, EPSON and RS are trademarks)

Actual graphics printed on an OKIDATA printer (shown reduced)

**SDUMP ..... \$20.00**

All prices subject to change without notice.

# CONTROL CRAFT INC.

19270 North Hills Drive • Brookfield, WI 53005 • (414) 784-9027

Name \_\_\_\_\_  
 Company \_\_\_\_\_  
 Address \_\_\_\_\_  
 City/State \_\_\_\_\_ Zip \_\_\_\_\_

Shipping address (if different from above)

Order Form: EPACK \_\_\_\_\_ @ \$150.00 = \_\_\_\_\_  
 BROM \_\_\_\_\_ @ \$ 25.00 = \_\_\_\_\_  
 EPG \_\_\_\_\_ @ \$105.00 = \_\_\_\_\_  
 MMB \_\_\_\_\_ @ \$ 30.00 = \_\_\_\_\_  
 SDUMP \_\_\_\_\_ @ \$ 25.00 = \_\_\_\_\_  
 UPGRADE NO. \_\_\_\_\_ @ \$ 15.00 = \_\_\_\_\_

Wis. residents add 5% sales tax \_\_\_\_\_

Chipping & Handling: # of items \_\_\_\_\_ x \$2.00/item = \_\_\_\_\_

**TOTAL ORDER: \$ \_\_\_\_\_**

TO ORDER BY MAIL: SEND MONEY ORDER, CERTIFIED CHECK, CASHIERS CHECK, MASTERCARD/VISA (include card number, inter-bank number, expiration date and signature).

**DEALER INQUIRIES WANTED (minimum dealer order is 10 units)**



## Race Or Demolition Derby— It Still Gets High Marks

The KAGRG gives *Space Race*, by Spectral Associates, very high marks for action, graphics and sound. We've stepped beyond the "graphics compare favorably with arcade games" stage with this one and are now in direct competition.

So who is this KAGRG? They are the videogame experts—at least in my house. The Knight Arcade Game Review Group consists of one 15-year old son, one 13-year old daughter, and—at least in this case—one wife, over 21. I use my 6809 machine for word processing and data storage, seldom do I venture into saving the cosmos from alien eradication.

I did have a go at *Space Race*, which in my case was more of a demolition derby. I was not quite good enough to be erratic, but if they gave points for kamikaze attacks I might have had a respectable score. Nimble my fingers ain't.

The Group was impressed. As a machine language program—which requires 16K but not Extended BASIC—it's extremely fast. Your highly maneuverable craft speeds around the rectangular "track" avoiding motionless Mines, floating Collectors, missiles from the Swarmers and the concerted attack of the Berserkers.

There is more going on in this game than in the parking lot at the Superbowl. Why you can even design a family handicapping system to give everyone a chance at the championship of the known universe—until the power goes off and all the scores are lost, that is.

When you first *EXECute* the program it tries to make friends by asking your name. Then it wants to know if you want keyboard or joysticks (we started with keyboard but quickly gave up—it's a lot easier to have the joystick think for you). Then it wants to know what skill level you want. With the options from 0 to 15, you have plenty of room to grow. Without exception the Group started with 1—I tried out the 0.

You are given a squadron of four ships and the various alien items pay from 25 to 600 points if you shoot 'em down. There is no time limit but the speed at which you are attacked makes the play go very fast. If you kill a Swarmer, a Collector becomes a Swarmer and if you leave a Swarmer alone too long it becomes a Berserker and immediately attacks you.

Clearing the screen of bad guys gets you another batch of bad guys—except that they get increasingly harder to shoot down. Higher level Collectors have to be shot twice and at the highest level the race track "infield" goes away leaving you no place to hide. At this point it's a literal free-for-all. For each 10,000 points scored you get another ship (with a limit of five at any one time), but your skill level is automatically advanced by two.

If (more like when) you lose your entire squadron the program displays the nine highest scores during that power-up period and asks if you want to play again. Pressing Y will get you another squadron at your original level and a new game.

The N gives someone else a chance to play as it goes back to the main menu and asks for name, skill level and joystick or keyboard.

The high score chart shows the name of the player, his or her score and the level at which it was earned. With basic handicapping skills you could even out the competition for all players.

While the game is designed to be played with joysticks or keyboard, we found that the keyboard required more personal memory than any of us was willing to provide. Trying to remember that "1" is counterclockwise rotation, right arrow was fire, left was thrust and clear was reverse made us thankful for joysticks. I would guess the ultimate competition to be a level 15 battle with keyboard on about the sixth wave of enemy.

The game is a winner for action lovers. In fact, even I got hooked on it, and I generally do not like shoot-'em-ups. The KAGRG couldn't even suggest where improvements could be made.

But the documentation could be improved. It is all there, even disk save instructions, but the presentation is not very logical. For instance, I found the loading instructions about two-thirds of the way down the page after the play instructions.

I'm renowned as a videogame cynic, and the worst I can say is that the instructions are illogical—this must be a good one.

(Spectral Associates Inc., 141 Harvard Ave., Tacoma, WA 98466)

—Glenn B. Knight

SPECTRAN

--SPECTACULATOR TO ASCII--

--ASCII TO SPECTACULATOR--



Use Your Word Processing Program  
To Include Spectaculator Tables In Your  
Reports

Run Spectaculator On Data Files Created  
Outside Of Spectaculator

Spectran is a easy to use program for unleashing the power of Disk Spectaculator. ML makes it quick. Works with ASCII compatible WP programs on 16K or 32K Disk systems. Use spreadsheet tables in your reports. Use downloaded data in Spectaculator. Easy to follow manual with examples. On diskette for \$25.00 postpaid.

DISK UTILITY PACKAGE

DIRDUPL -  
Simple program for protecting and restoring many bombed diskettes.

DISKLOOK -  
-> Disk utility program to examine and change data bytes on diskettes.  
-> File analysis.  
-> List granules allocated to a disk file.  
-> Alter Directory contents.  
-> Simultaneous listing of diskette data contents in ASCII and HEX formats.  
-> User friendly.

The DISK UTILITY PACKAGE including DIRDUPL, DISKLOOK, and manuals on diskette for \$15.00 postpaid.

INTRODUCTORY OFFER!

For a limited time, if you order Spectran at \$25.00 we will include the DISK UTILITY PACKAGE and manuals at no extra cost. Now that's a bargain!

CRIMSON SOFTWARE  
The RESEARCH ASSOCIATES Group  
32 Beverly Heights  
Tuscaloosa, Alabama 35404

# For the Ultimate in Games, Look to Radio Shack's TRS-80®

## Exciting Poltergeist Game Just Like the Movie

A Radio Shack exclusive! Unless you complete three levels of eerie play, you don't stand a "ghost" of a chance of rescuing Carol Anne! First you must discover the clues. Next climb the hazardous stairs. Then it's time to destroy the poltergeist—if you can! (Cat. No. 26-3073, \$34.95)



Enjoy these exciting games with Radio Shack's TRS-80 Color Computer (26-3004, \$299.95) and joystick controllers (26-3008, \$24.95). Attaches to any TV (not included).

## Choose From Over 40 Games Like These!



**Mega-Bug.** It's a maze of fun as you try to lose and confuse the little "buggers" hot on your trail! (26-3076, \$34.95)

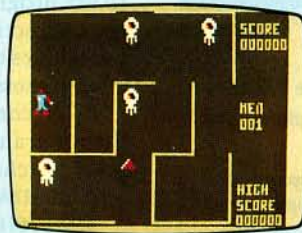

**Monster Maze.** Thread your way through an evil dungeon to find the gold. Beware of laser-firing monsters! (26-3081, \$29.95)



**Microbes.** You're the disinfectant, shooting antibiotics at deadly germs. 15 levels of nasty difficulty. (26-3085, \$24.95)



**Clowns and Balloons.** Bounce a "monkey-suited" clown high enough off the net to pop the balloons above. (26-3087, \$29.95)



**Shooting Gallery.** Hit moving targets for points in a whimsical carnival atmosphere. Lots of surprises! (26-3088, \$29.95)

**Radio Shack®**  
The biggest name in little computers®  
A DIVISION OF TANDY CORPORATION

Send me your free TRS-80  
Computer Catalog today!

Mail To: Radio Shack, Dept. 83-A-659  
300 One Tandy Center  
Fort Worth, Texas 76102

NAME \_\_\_\_\_  
ADDRESS \_\_\_\_\_  
CITY \_\_\_\_\_  
STATE \_\_\_\_\_ ZIP \_\_\_\_\_

Retail prices may vary at individual stores and dealers. Poltergeist © 1982 Metro-Goldwyn-Mayer Film Co. and SLM Entertainment, Ltd.



## ECM: Your Money's Worth And A Basic Bonus

*ECM, Electricity Consumption Monitor*, from CoCoDATA Enterprises offers a lot more than the advertisements suggest. In addition to a very neat, compact energy monitoring routine, it offers a few nice BASIC programming techniques.

The ads that offer full refund if not completely satisfied offer some comfort in purchasing software through the mail. This is the claim of CoCoDATA for their product ECM. They should have very few claims for refunds.

The documentation leads you through the setup very painlessly. It even includes a short course on reading your electric meter. This is the part your computer won't do for you.

The program uses the information from your utility bill and from daily readings you make of your electric meter. This information must be placed in the body of the program, following the format guidelines provided in the instructions. The billing information is listed in the program as Line 200 BIS(1)=date, consumption & amount.

The meter readings are entered as Line 100DATA date & meter reading. The program has sufficient line space set up for one year without modification of the program. The author has chosen this method of data storage to eliminate the use of a separate data file tape.

Once the information is entered in the program, *RUN* and computed, you are presented with a menu to select: (1) 30

days consumption in dollars or KWH, (2) Graph of last 60 days use or (3) Next months bill projected with 20 day trend analysis.

Selecting item one will provide a screen list of the electricity usage by date in terms of dollars or KWH. It will also calculate the high, low and average use for those 30 days.

Item two presents a nice hi-res bar graph for a 60 day period. The graph can be dumped to the printer using one of the many screen print routines available such as the one from Custom Software Engineering. The graph has a unique feature in that it marks the average value of all plots with a tic mark just left of the vertical axis.

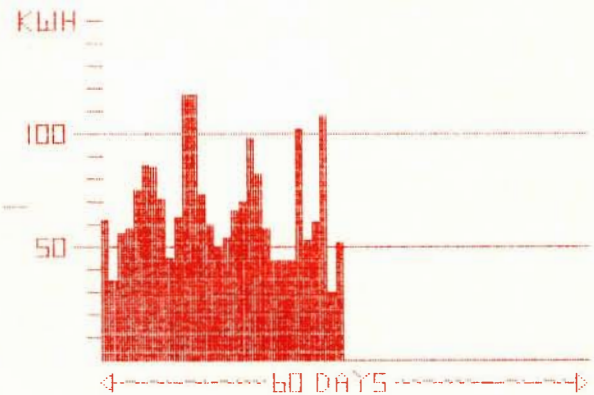

Item (3) will display a trend analysis indicating a percentage increase or decrease in consumption.

The extras you get with the program are the author's programming techniques. You can learn how he handles dated information or draw a nifty little bar graph or how he does a trend analysis or how to select ranges in data or how to use program insertions for data updates. All of this, plus the instruction booklet, includes a few energy conservation techniques that you can apply and then monitor their actual effectiveness.

*ECM* comes with sample data included to demonstrate the program and will run on 16 or 32K Extended Basic. A good purchase for your utility library.

(CoCoDATA Enterprises, 1215 Emerald Dr., Orlando, FL 32808, \$10.45 cassette)

—Ed Sehlhorst

## "SEE" MUSIC!!

- The **KALEIDOPHONE** allows your Color Computer to "listen to" your hi-fi and display what it "hears" on your TV!
- Built-in interface circuitry lets the computer devote full-time to creating the displays, so breath-taking, animated pictures in full color are easy to program.
- Just plug the **KALEIDOPHONE** into hi-fi and joystick inputs.
  - Do not confuse with imitations — the **KALEIDOPHONE** continuously delivers actual volume signals (64 levels on each of 4 channels). Works on any CoCo.
- Users' newsletter (FREE with purchase) contains dozens of new display ideas in each issue — a literally infinite variety of patterns is possible!
  - The **KALEIDOPHONE** is something really new. Great for parties! Order Now!
- Only \$49.95 fully assembled. Kit version: \$34.95. Both versions include operating software and full instructions. **BONUS:** free issue of **KALEIDOPHONICS!**

**NEW SALEM RESEARCH**  
West Main Street  
New Salem, Mass. 01355



# KALEIDOPHONE

Hint . . .

## Saving In ASCII

When you *SAVE* programs, CoCo can perform this function in two ways, by using binary codes or actual letters and numbers (called ASCII and pronounced AS-KEY).

Although it takes longer, ASCII sometimes is a more accurate way to *SAVE* a program, especially when you may be transferring programs between systems—say from a disk-based to a cassette-based system.

To *SAVE* in ASCII, simply add a comma and an "A" to the end of your *SAVE* instruction, like this: *CSAVE "PROGRAM",A* and the ASCII *SAVE* will be done by CoCo.



# TOM MIX SOFTWARE

•FOR THE COLOR COMPUTER & TDP 100 • 3424 College N.E., Grand Rapids, MI 49505 (616) 364-4791•

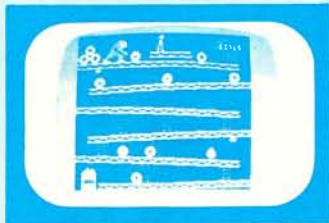

## THE KING

1982  
32K Machine Language  
**\$26.95 tape**  
**\$29.95 disk**

**ARCADE ACTION** - How high can you climb? Four full graphic screens. Exciting Sound - Realistic graphics. Never before has the color computer seen a game like this. Early reviews say: Just like the arcade - Simply outstanding!

## PROTECTORS

Exciting fast paced arcade game that looks and plays like the popular arcade game "DEFENDER". Wave after wave of enemy fighters drop bombs on your city. Destroy them before they destroy your city. Soon the mother ships appear firing laser blasts at you. Watch for the heat seeking mines. Your defense includes your laser cannon plus four smart bombs on each of your four ships. A new ship with each 5,000 points. High resolution graphics with four colors make this new 32K arcade game the one for others to follow.

**\$24.95 TAPE \$27.95 DISK**



## COLOR GOLF

Now sit at your computer and play nine or eighteen holes. Outstanding graphics in the fairway or on the green. Helps your game.  
**32K EXTENDED BASIC \$17.95**

**BIRD ATTACK**-A fast paced machine language arcade game. Shoot the birdmen before they descend upon you. Watch out for their bombs! **16K Machine Language \$21.95**

**MAZE RACE**-Maze race is a one or two player game. Play either against the built in timer or against your favorite opponent. **16K Machine Code \$17.95**

**SOLO POOL**-Now play pool with your color computer. Two players. Plays like machine language. Super color. High resolution graphics. **16K Ext. Basic \$17.95**

## OTHER GREAT GAMES

ALL PROGRAMS REQUIRE 16K

**MOON LANDER**•Fantastic Graphics. Land on the Moon if you can. 2 Programs. Ext. Basic **\$17.95**

**DANCING DEVIL**•Watch him dance to music or program him yourself. Machine Language. **\$14.95**

**WAR KINGS**•Battle to save your castle and king. High resolution graphics with outstanding sound make this one a real winner. **16K Machine Language \$17.95**

## ADVENTURES

**TREK-16**•Travel thru space with Spock and Capt. Kirk. Adventure. Tough! Ext. Basic. **\$17.95**

**SHIPWRECK**•Escape from a desert isle if you can. Great Adventure! Ext. Basic. **\$14.95**

**ESCAPE FROM SPECTRE (Graphic Adventure)**•You are a secret agent for British Intelligence sent on a mission to obtain the secret nerve gas formula being developed by S.P.E.C.T.R.E. to destroy the world. **16K Ext. Basic \$17.95**



## SPACE SHUTTLE

1983  
32K Ext. Basic

**\$28.95 TAPE ONLY**

This program gives you the real feeling of flight. Full instrumentation complete to the max. Actual simulation of space flight. **32K Ext. Basic**



## TRAP FALL

by Ken Kalish

The "Pitfalls" in this game are many. Hidden treasures, jump over the pits, swing on the vine, watch out for alligators, beware of the scorpion. Another game for the Color Computer with the same high resolution graphics as "The King". Requires 16K  
**Tape 27.95**

## KATERPILLAR ATTACK

Outstanding graphics and sound will end all of those trips to the arcade. So much like the arcade you have to see it to believe it. Requires Ext. Basic.  
**16K MACHINE LANGUAGE \$21.95**  
**DISK \$24.95**



## UTILITIES

**COLOR MONITOR**-Written in position independent code. (May be located in any free memory). Very compact. Only occupies 1174 bytes of memory. Full Featured. Includes Break-Pointing of machine language programs, register display and modify, memory display and modify, and block memory move commands. Displays memory in hex and ascii format on one line 8 bytes long. **MACHINE LANGUAGE \$24.95**

**ROM**-This program is a utility that will move "most" 8K Rom-Packs to disk and allow you to run them from disk. Easy to use. Requires 64K. **\$17.95**

**SCREEN PRINT ROUTINE**-Using your Epson or Microline Printer. Print the screen contents on a full size 8½ x 11 sheet. **16K Ext. Basic \$17.95**

**TAPE DUPE**—Brand new machine language program that copies any tape effortlessly. Completely automatic. **\$16.95**

**DISK TO TAPE**-Dump the contents of any disk to tape automatically. Machine Language. **\$17.95**

**TAPE TO DISK**-Load the contents of any tape to disk automatically. Machine Language. **\$17.95**

**MAIL LIST**-Maintain a complete mailing list with phone numbers etc. Ext. Basic. **\$17.95**

**THE FIXER**-Having trouble moving those 600 Hex programs to disk? The fixer will help. Completely automatic. **\$17.95**

**TAPE CAT**-All new machine language program lists contents of tapes to printer. Make a catalog of your tapes. **\$17.95**

**PROGRAM PRINTER UTILITY**-This program will list basic programs to your printer in two column format. Saves paper and makes your listing look professional. Disk based. **\$17.95**



ADD \$1.00 POSTAGE & HANDLING • TOP ROYALTIES PAID  
MICHIGAN RESIDENTS ADD 4% SALES TAX • LOOKING FOR NEW SOFTWARE

**\*TO PLACE ORDERS AFTER 5:00 P.M. CALL OUR BBS AT 616-364-4791**



**SEE YOU AT RAINBOW FEST**



# The Horses Are Nearing The Starting Gate...



Program by  
Rob Becker

Now that springtime has gotten a good foothold around and about, the thoughts of some young innocents have turned to that traditional befuddler of mind and body chemistry called love. But the stars in the eyes of many another older (but not wiser) head are there in anticipation of the season's parimutuel betting which will be taking place on the grounds of this nation's many venerable ovals.

Particularly, on the first Saturday of May, the attention of sporting-minded folk around the world will be focused on a patch of turf in the heart of Louisville, which for over a century has hosted the world's premier horse race, the ultimate championship for three-year-old thoroughbreds, the Kentucky Derby.

The track, of course, is Churchill Downs. And the excitement that spring day will be shared on the grounds by a community of over 150,000 novices, pros, horsemen, innocents and touts—all reaching for the gold ring: that winning parimutuel ticket on the big one.

Whether or not you are so fortunate as to be at "the Track" that day, we have here a little racing program in honor of the Kentucky Derby with which you might want to test your luck. Rob Becker, of Smithtown, New York, didn't write this program specifically for the Derby, but at this time in Kentucky when folks have just polished up their silver julep cups and dusted off their worn copies of Irvin S. Cobb's recipe for muddled mint and Bourbon, it's the only race that comes to mind.

The program accepts win, place and show betting, and allows you to make your pick from an eight-horse field. The day's 'card' contains 10 races, and you may bet any amount

up to your total holdings on any race. You are spotted \$100 at post time.

The program is self-prompting, but . . . psst . . . before you go trackside, let me give you a tip: play the filly—she'll run her heart out.

—Courtney Noe

80	03EB
210	0747
310	0B30
430	0F5D
END	1534

The listing:

```

1 ' *** HORSE RACING ***
2 ' BY ROB BECKER
10 BL$=CHR$(128):B1$="horse":B2$
="racing":B3$="by":B4$="rob":B5$
="becker":FORX=1TO15:CL=RND(8):C
LS(CL):PRINT@106,B1$;BL$;B2$;:SO
UNDX*3,1:NEXT:CLS:PRINT@106,B1$
;BL$;B2$;:PRINT@265,B3$;BL$;BL$;
B4$;BL$;B5$;:SCREEN0,1
20 HT=0:FORJK=1TO7:HT=HT+16:H$(J
K)=CHR$(143+HT):NEXT:H$(8)="G":H
C=0:FORHN=1TO7:HC=HC+16:H1$(HN)=
CHR$(128)+CHR$(131+HC)+CHR$(142+

```

```

HC):H2$(HN)=CHR$(128)+CHR$(136+H
C)+CHR$(136+HC):NEXT:H1$(8)=CHR$
(128)+CHR$(131)+CHR$(142)
30 FORX=160TO189:PRINT@X,H1$(7);
:PRINT@X+32,H2$(7);:SCREEN0,1:FO
RY=1TO100:NEXTY:NEXTX
40 H3$=CHR$(128)+CHR$(128):H4$=C
HR$(128)+CHR$(128):H2$(8)=CHR$(1
28)+CHR$(136)+CHR$(136):POKE6549
5,0:CLS:PRINT"*** HORSE RACING *
**":PRINT"BY ROB BECKER":PRINT:I
NPUT"DO YOU WANT INSTRUCTIONS";I
$:IFI$="Y"THENGOSUB410
50 PRINT:INPUT"HOW MANY PLAYERS(
1-8)";PL:IFPL<1 OR PL>8THEN50ELS
EFORX=1TOPL:DD(X)=100:NEXT
60 FORX=1TOPL:PRINT:PRINT"BETTER
";X;"'S NAME";:INPUTA$(X):NEXT
70 IFRA=10THEN320ELSEFORX=1TO8:M
V=RND(7):H(X)=MV:NEXTX:CLS0:RA=R
A+1:PRINT"*** HORSE RACING ***":
PRINT"RACE #";RA:PRINT"HORSES"
80 FORX=1TO8:P=RND(0):SH=RND(0):
P=P+1:SH=SH+2:PRINTX" ";H$(X);"
";:PRINTUSING"$###.##";H(X);:PRI
NT" ";:PRINTUSING"$###.##";H(X)/P
;:PRINT" ";:PRINTUSING"$###.##";H
(X)/SH:NEXT
90 IFRA>1THEN100ELSEFORX=1TOPL:G
OTO140
100 PRINT@41,"*":PRINT@73,"*":PR
INT@43,"RESULTS OF RACE #";RA-1:
PRINT@75,"1ST. ";H$(HP(1));" 2ND
. ";H$(HP(2));" 3RD. ";H$(HP(3))
:PA=0:FORX=1TOPL
110 IFDD(X)=<0THENNEXTX
120 FORI=1TOPL:IFDD(I)>0THEN140E
LSENEXTI
130 GOTO320
140 PRINT@384,A$(X)"'S BET":PRIN
T"YOU HAVE ";:IFDD(X)<100THENPRI
NTUSING"$###.##";DD(X)ELSEPRINTU
SING"$ ###.##";DD(X)
150 FORS=448TO479:PRINT@S,CHR$(1
43);:NEXTS:PRINT@448,"WHICH HORS
E";:INPUTBB(X):IFBB(X)>8 OR BB(X
)<1THEN140
160 PRINT@448,"1-WIN 2-PLACE 3-S
HOW";:INPUTWS(X):IFWS(X)<1 OR WS
(X)>3THEN160
170 FORY=448TO479:PRINT@Y,CHR$(1
43);:NEXTY:PRINT@448,"MONEY(1-";
:PRINTUSING"###.##";DD(X);:PRINT
)";:INPUTMN(X):IFMN(X)<.01 OR M
N(X)>DD(X)THEN170ELSENEXTX
180 CLS0:FORX=62TO63:FORY=0TO31:
SET(X,Y,5):NEXTY,X:L=0:FORX=0TO5
11STEP64:L=L+1:PRINT@X,H1$(L);:P
RINT@X+32,H2$(L);:NEXT
190 FORX=1TO1000:NEXT:PLAY"L4T50

```

```

2CFA03L8CT7P8CP64CP64CP802T5L8AT
7P8AP64AP64AP8T5L8.F03C02FL1CL4P
2CFA03L8CT7P8CP64CP64CP802T5L8AT
7P8AP64AP64AP8T5L8.CP64CP64CL1F"
200 A=0:B=128:C=192:D=256:E=320:
F=384:G=448:HH=64
210 X=RND(8)
220 ON X GOTO 230,240,250,260,27
0,280,290,300
230 IFA=29THENPRINT@A+1,H3$;:PRI
NT@A+33,H4$;:GOTO210ELSEIFX=1THE
NS=RND(8):IFS<H(1)THEN210ELSEA=A
+1:PRINT@A,H1$(1);:PRINT@A+32,H2
$(1);:IFA=29THENZC=1:GOSUB400
240 IFHH=93THENPRINT@HH+1,H3$;:P
RINT@HH+33,H4$;:GOTO210ELSEIFX=2
THENS=RND(8):IFS<H(2)THEN210ELSE
HH=HH+1:PRINT@HH,H1$(2);:PRINT@H
H+32,H2$(2);:IFHH=93THENZC=2:GOS
UB400
250 IFB=157THENPRINT@B+1,H3$;:PR
INT@B+33,H4$;:GOTO210ELSEIFX=3TH
ENS=RND(8):IFS<H(3)THEN210ELSEB=
B+1:PRINT@B,H1$(3);:PRINT@B+32,H
2$(3);:IFB=157THENZC=3:GOSUB400
260 IFC=221THENPRINT@C+1,H3$;:PR
INT@C+33,H4$;:GOTO210ELSEIFX=4TH
ENS=RND(8):IFS<H(4)THEN210ELSEC=
C+1:PRINT@C,H1$(4);:PRINT@C+32,H

```



**Use Color Power.**

ColorZAP uses the power of the Color Computer to provide both rapid scanning and full screen modification capabilities.

- Recover killed and clobbered files.
- Find unreadable disk sectors.
- Modify nibbles in hexadecimal.
- Copy sectors to same or different drive.
- Use color power to scan disk data.

Here's what the reviewers said...

About the program: "ColorZAP is a powerful program that allows you to see what is on the disk, modify it and, if possible, recreate it. Menu-driven, ColorZAP is extremely easy to use and well-documented...A good offering." — The RAINBOW, September 1982

About the manual: "A 24-page manual is included that describes program operation in detail. It also provides valuable information on the important disk system parameters." — MICRO, December 1982

For the TRS-80 Color Computer. Available on disk with an accompanying manual from **Software Options**, 19 Rector Street, New York, NY, 10006. 212-785-8285. **Toll-free order line: 800-221-4624.** Price: \$49.95 (plus \$2.00 per order shipping and handling). New York State residents add sales tax. Visa/Mastercard accepted.





# We're the Source for Your Courseware



## 128 Full-time Audio Talk/Tutor Programs! In color, with pictures and text!

All our TRS-80 Color programs have easy to understand professional announcer narration, not synthesized, robotic voices. All text is displayed in easy to read upper- and lower-case characters. Video clearly illustrates key concepts in each frame of the program.

Programs for your TRS-80 Color Computer:

### LANGUAGE ARTS

Spelling	(16 programs)
Level 3-4 (words in context with definitions and synonyms)	(16 programs)
Phonics	(16 programs)
English as a Second Language	(32 programs)

### MATHEMATICS

Level 1-6 Numbers	(16 programs)
Basic Algebra	(16 programs)

### SCIENCE & TECHNOLOGY

Physics	(16 programs)
---------	---------------

Only \$4.95 per program! (\$9.90 for 2, one on each side). \$79.00 for 16 in an album. \$59.00 for 16 in a box. Send \$1.00, refundable, for catalog of 1000 programs for Atari, Mod III, etc.



**DORSETT**  
Educational Systems, Inc.

(405) 288-2300  
Box 1226, Norman, OK 73070



```

2$(4);: IFC=221 THEN ZC=4: GOSUB 400
270 IFD=285 THEN PRINT@D+1, H3$;: PR
INT@D+33, H4$;: GOTO 210 ELSE IFX=5TH
ENS=RND(8): IFS<H(5) THEN 210 ELSE D=
D+1: PRINT@D, H1$(5);: PRINT@D+32, H
2$(5);: IFD=285 THEN ZC=5: GOSUB 400
280 IFE=349 THEN PRINT@E+1, H3$;: PR
INT@E+33, H4$;: GOTO 210 ELSE IFX=6TH
ENS=RND(8): IFS<H(6) THEN 210 ELSE E=
E+1: PRINT@E, H1$(6);: PRINT@E+32, H
2$(6);: IFE=349 THEN ZC=6: GOSUB 400
290 IFF=413 THEN PRINT@F+1, H3$;: PR
INT@F+33, H4$;: GOTO 210 ELSE IFX=7TH
ENS=RND(8): IFS<H(7) THEN 210 ELSE F=
F+1: PRINT@F, H1$(7);: PRINT@F+32, H
2$(7);: IFF=413 THEN ZC=7: GOSUB 400
300 IFG=476 THEN PRINT@G+1, H3$;: PR
INT@G+33, H4$;: GOTO 210 ELSE IFX=8TH
ENS=RND(8): IFS<H(8) THEN 210 ELSE G=
G+1: PRINT@G, H1$(8);: PRINT@G+32, H
2$(8);: IFG=476 THEN ZC=8: GOSUB 400
310 GOTO 210
320 CLS: PRINT "*** HORSE RACING *
**": PRINT "GAME OVER": PRINT: PRINT
"FINAL SCORES : ": PRINT: FORY=1 TO 8
00: NEXT: FORX=1 TO PL: PRINT A$(X); "
$"; DD(X): FORY=1 TO 800: NEXT Y: NEXT X
: END
330 FORQ=1 TO PL: IF WS(Q)=1 THEN 340 E
LSE IF WS(Q)=2 THEN 360 ELSE 380
340 IF BB(Q)=HP(1) THEN DD(Q)=DD(Q)
+MN(Q)*H(BB(Q))/2 ELSE DD(Q)=DD(Q)
-MN(Q): NEXT Q: GOTO 70
350 NEXT Q: GOTO 70
360 IF BB(Q)=HP(1) OR BB(Q)=HP(2)
THEN DD(Q)=DD(Q)+MN(Q)*H(BB(Q))/P
/2 ELSE DD(Q)=DD(Q)-MN(Q): NEXT Q: GO
TO 70
370 NEXT Q: GOTO 70
380 IF BB(Q)=HP(1) OR BB(Q)=HP(2)
OR BB(Q)=HP(3) THEN DD(Q)=DD(Q)+M
N(Q)*H(BB(Q))/SH/2 ELSE DD(Q)=DD(Q)
-MN(Q): NEXT Q: GOTO 70
390 NEXT Q: GOTO 70
400 PA=PA+1: HP(PA)=ZC: IF PA=>3 THE
N 330 ELSE RETURN
410 CLS: PRINT "*** HORSE RACING *
**": PRINT: PRINT " YOU ARE GIVEN $
100 TO START OFF THE GAME. ON
CE THE GAME HAS STARTED, YOU WIL
L SEE THE LIST OF HORSES, AND H
OW MUCH THEY PAY OFF."
420 PRINT " EACH HORSE IS NUMBE
R D, SO WHEN YOU CHOOSE THE HO
RSE YOU WISH TO BET ON, TYPE T
HE NUMBER THAT REPRESENTS THAT H
ORSE. YOUR HORSE IS IDENTIFI
ED BY IT'S COLOR. 'G' REPRES
ENTS GREEN ON THE CHART."
430 A$=INKEY$: IFA$="" THEN 430 ELSE

```

# FINALLY!

## A REAL SPREAD-SHEET PROGRAM FOR THE COLOR COMPUTER

# DYNACALC™

Business people use spread-sheets to organize columns and rows of figures. DYNACALC simulates the operation of a spread-sheet without the mess of paper and pencil. Of course, corrections and changes are a snap. Changing any entered value causes the whole spread-sheet to be re-calculated based on the new constants. This means that you can play, 'what if?' to your heart's content.

But DYNACALC isn't just for accountants. DYNACALC can be used for just about any type of job. Not only numbers, but alphanumeric messages can be handled. Engineers and other technical users will love DYNACALC's sixteen-digit math and built-in scientific functions. There's even a built-in sort command, so you can use DYNACALC to manage small data bases - up to 256 records.

DYNACALC will let your computer do just about anything you can imagine. Ask your friends who have VisiCalc, or a similar program, just how useful an electronic spread-sheet program can be for all types of household, business, engineering, and scientific applications.

DYNACALC is designed to be used by non-programmers, but even a Ph.D. in Computer Science can understand it. Built-in HELP messages are provided for quick reference to operating instructions.

DYNACALC has a beautifully simple method of reading and writing FLEX data files, so you can communicate both ways with other programs on your system, such as the Text Editor, Text Processor, Sort/Merge, RMS data base system, or other programs written in BASIC, C, PASCAL, FORTRAN, and so on.

Except for a few seldom-used commands, DYNACALC is memory-resident, so there is little disk I/O to slow things down. The whole data array (worksheet) is in memory, so access to any point is instantaneous. DYNACALC is 100% 6809 machine code for blistering speed.

Color Computer DYNACALC works with the FLEX operating system from Frank Hogg Laboratory (64k required). If you aren't already using this powerful operating system, we have a special deal for you: order DYNACALC (regularly \$200) and FHL Color FLEX (regularly \$99) together for only \$250.

To order, see your local DYNACALC dealer, or order directly from CSC at the address below. We accept telephone orders from 10 am to 6 pm, Monday through Friday. Call us at 314-576-5020. Your VISA or MasterCard is welcome. Be sure to specify that you want the Color Computer version.

## ORDER YOUR DYNACALC TODAY!

Computer Systems Center  
13461 Olive Blvd.  
Chesterfield, MO 63017  
(314) 576-5020





## COLOR COMPUTER SOFTWARE

### ★ UNIVERSAL PROGRAM 1(UP-1) ★

Known as the Program Stacker, UP-1 allows several programs to be loaded until the memory is filled. Quickly jump from one program to another or compose new programs while retaining the old ones. Programs are included for patching damaged programs. Allows data or machine language programs to be stored and retrieved from a cassette. Programs are included for writing values or characters to memory, and displaying memory contents. Blocks of memory can be relocated. UP-1 can be used as a Word Processor by allowing text to be stored in memory and printed on the screen or an external printer. UP-1 Cassette \$14.95.

### ★ DISASSEMBLER-ASSEMBLER (DISASM) ★

Using English mnemonics and Decimal Locations, DISASM is an easy way to learn to assemble machine Language Programs or Subroutines. Subroutines can be used with Basic Programs and called by either `USR` or `EXEC` commands. For CC compatibility, all locations are given in Decimal Values eliminating the confusion associated with using HEX. All commands are Menu oriented and the user provides the particulars for the commands without having to remember command formats. The Disassembler can be used to Analyze Machine Language Programs as well as the Basic and Extended CC ROMS. Example programs are included. Cassette \$19.95.

### ★ TERMINAL PROGRAM (DYTERM) ★ *new*

DYTERM is designed to convert a Color Computer into a terminal. Use it to send and receive information from another computer, another terminal, or use it to provide the software needed for sending and receiving information over telephone lines with a MODEM. DYTERM is a BASIC program with Machine Language Subroutines. Cassette \$14.95.

**EXTENDED BASIC is not REQUIRED. All programs require a 16K Computer and are DISC compatible.**

## HARDWARE ITEMS

Increase your computer's memory with the following Memory Expansion Kits. Soldering is not required but your warranty will be voided by removing the cover. The kits carry a one year warranty.

ME-1 upgrades 4K to 16K	\$19.95
ME-2 upgrades 4K to 32K	\$59.95
ME-3 upgrades 16K to 32K	\$39.95
ME-4 upgrades all CC to 64K	\$99.95

Note: A 1.1 ROM is required for ME-4

6809E Microprocessor Chip	\$19.95
6821 Peripheral Interface Adapter	\$6.95
EXTENDED BASIC ROM	\$85.00

## WE REPAIR COMPUTERS

### ★ PUT YOUR PROGRAMS IN A PROM PACK ★

We will put your Machine Language and/or BASIC Programs in a Cartridge. Send us your program on a Cassette and we will return a Cartridge with your program in it. The cost is \$19.95 for up to 4K and \$29.95 for up to 8K. Add \$2 for shipping.

ATTENTION SOFTWARE PROGRAMMERS: We are looking for good original programs and are willing to pay high ROYALTIES for them. Write or call for details.

### DEALERS INQUIRIES INVITED

Checks, VISA & MC Cards Add \$1 shipping

## DYNAMIC ELECTRONICS INC.

P.O. Box 896 Hartselle, AL 35640 (205) 773-2758

```
CLS:PRINT" THE ROWS OF PRICES, R
EPRESENT THE AMOUNT OF MONEY YO
U WIN FOR THAT HORSE. ROW 1 TELL
S YOU HOW MUCH MONEY YOU WIN, IF
YOUR HORSE COMES IN FIRST."
44Ø PRINT" ROW 2 TELLS YOU HOW M
UCH YOU WIN IF YOUR HORSE COME
S IN 1ST. OR 2ND. AND ROW 3 TELL
S YOU HOW MUCH MONEY IF YOUR HOR
SE FINISHES 1ST,2ND OR 3R
D."
```

```
45Ø A$=INKEY$: IFA$=""THEN45ØELSE
CLS:PRINT" DURING THE TIME YOU A
RE ASKED TO BET ON HORSE, YOU A
RE ASKED TO CHOOSE WIN, PLACE O
R SHOW. I WILL DESCRIBE THIS P
ROCEDURE."
```

```
46Ø PRINT" WIN-- IF YOU CHOOSE W
IN, YOUR HORSE MUST FINISH FIRS
T. FOR EVERY $2 YOU BET YOU R
ECIEVE THE AMOUNT OF MONEY TH
AT YOUR HORSE PAYS FOR A WIN.
IF YOUR HORSE DOES NOT FINISH
FIRST, YOU LOSE THE AMOUNT OF
MONEY YOU BET."
```

```
47Ø A$=INKEY$: IFA$=""THEN47ØELSE
CLS:PRINT" PLACE-- IF YOU CHOOSE
PLACE YOUR HORSE MUST COME I
N FIRST OR SECOND. ALL THE OTH
ER PROCEDURES FOLLOW THE
SAME RULE AS 'WIN'.":PRINT" SHOW
-- YOUR HORSE MUST FINISH 1ST,
2ND, OR 3RD."
```

```
48Ø PRINT"ALL OF THE REST OF THE
PROCEDURES ARE THE SAM
E AS 'WIN'AND 'PLACE' "
```

```
49Ø A$=INKEY$: IFA$=""THEN49ØELSE
CLS:PRINT" REMEMBER : YOU WIN MO
RE MONEY IF YOU CHOOSE 'WIN' AN
D YOUR HORSE COMES IN FIRST,
BUT YOU WIN MORE OFTEN CHOOSIN
G 'PLACE' OR 'SHOW'. ALSO, A HOR
SES SPEED DEPENDS ON HOW MUCH A
HORSE PAYSOFF."
```

```
50Ø PRINT" A HORSE THAT PAYS OFF
$3, IS FASTER THAN A HORSE TH
AT PAYS OFF $6. THE LOWER THE
HORSE PAYSOFF, THE FASTER THE HO
RSE IS. IF YOU RUN OUT OF MONE
Y, YOU LOSE, AND YOU ARE OUT
OF THE GAME."
```

```
51Ø A$=INKEY$: IFA$=""THEN51ØELSE
CLS:PRINT" IF THERE ARE ANY OTHE
R PLAYERS IN THE GAME, THE GAME
CONTINUES.AFTER 1Ø RACES THE GAM
E IS OVER AND EVERYONES MONEY LE
FT IS SHOWN. YOU CAN NOT BET
MORE MONEY THEN YOU HAVE."
52Ø RETURN
```

# GIVE YOUR CHILD AN UNFAIR ADVANTAGE



Don't just depend on others to provide the basic education your child needs to succeed in tomorrow's world. While test scores of others may go down, your child's scores can improve dramatically when you provide him or her with individualized MICRO SCHOOL PROGRAMS, in Reading, Math, English Usage, Spelling, and Games that Teach. Learning at home can be fun.

He or she can master basic skills, using a MICRO SCHOOL PROGRAM, in just minutes each day if you have an APPLE, ATARI, TRS-80, TRS-80 COLOR or TDP personal computer at home.



**ASK FOR MICRO SCHOOL PROGRAMS BY NAME at your local computer store.**

**BERTAMAX INC.**  
101 Nickerson #202  
Seattle, WA 98109  
(206)282-6249  
© 1982, Bertamax, Inc.



**PERSONALIZED INSTRUCTION ON PERSONAL COMPUTERS**



# Pop Quiz

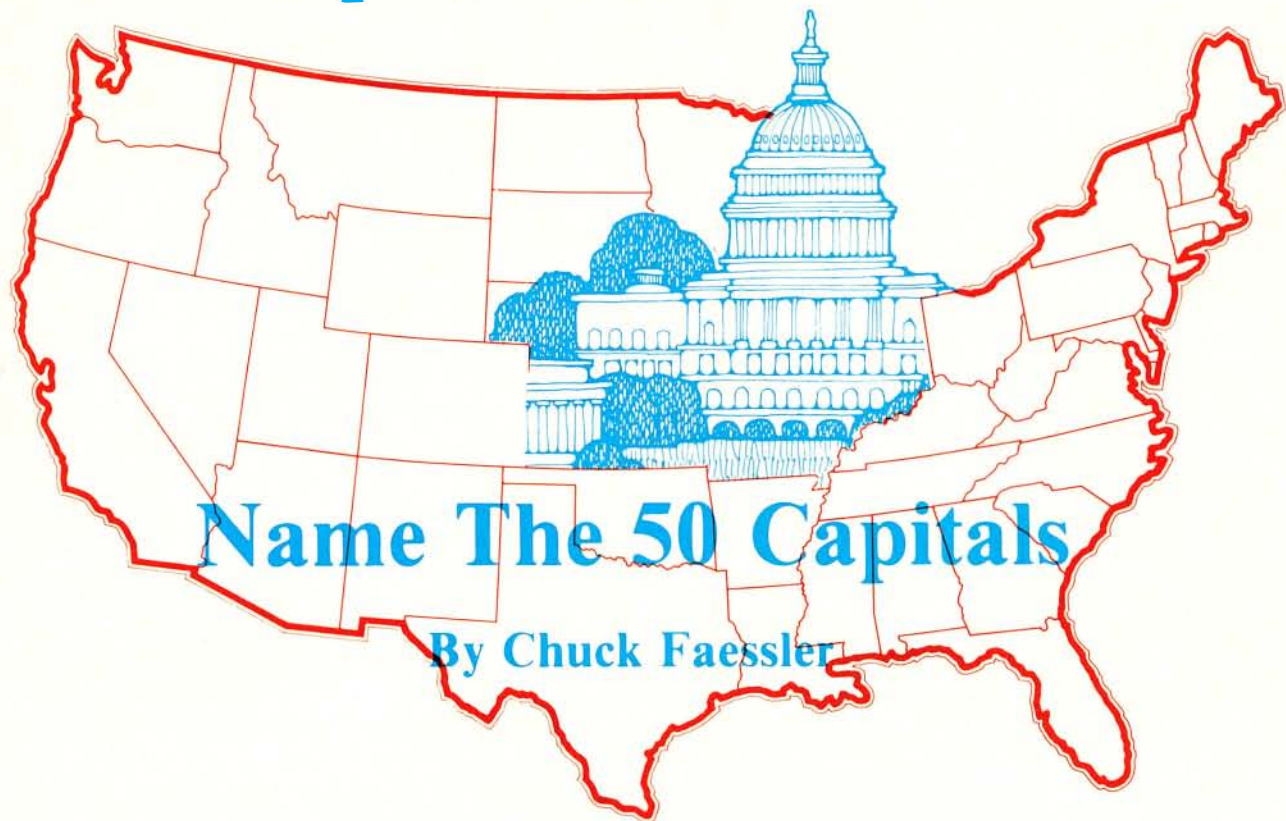

*States and Capitals* is a short program which may be helpful with your children's homework. It is a question and answer drill to aid in the learning of all 50 states and capitals. It also can be easily modified to be used with other question-answer drills.

After the basic program is loaded with *CLOAD*, type *RUN*. The instructions are then displayed along with the first question. If the answer is correct, another question will be displayed. The computer allows you two chances to answer the question correctly; if you are wrong on both tries, it will display the answer and then repeat the question. After completing 10 questions, your score is calculated and displayed. At this time you are given the opportunity to continue or stop.

The states and capitals can be reversed by changing the following:

- Line 80—SWAP STATES AND CAPITALS
- Line 150—REPLACE CAPITAL AND A\$(I) WITH STATE AND B\$(I)
- Line 160—REPLACE B\$(I) WITH A\$(I)
- Line 380—REPLACE B\$(I) WITH A\$(I)

Here is a short description of some important lines:

Lines 30-60—Dimension Arrays, read the data into those arrays

- Line 80—Instructions
- Line 100—Sets # of questions to 10
- Lines 110-130—Random number generates to select questions, checks that the same RND is not repeated successively
- Line 150—Question format
- Line 180—Sets counter for 2 tries to answer question
- Lines 260-290—Scoring routine
- Lines 320-360—Data for arrays

190	027F
320	054D
END	08CD

The listing:

```

10 ' STATES AND CAPITALS
20 ' CHUCK FAESSLER FEB 1983
25 ' 617 CAMERON COURT
26 ' KENNER, LA. 70062
30 CLS: CLEAR 1000
40 DIM A$(50), B$(50)
50 FOR I=1 TO 50
60 READ A$(I), B$(I): NEXT I
    
```

JUST  
THE  
BEST

# The RAINBOW

THE COLOR COMPUTER MONTHLY MAGAZINE

It's called the premier Color Computer magazine for good reason. **The Rainbow** is the biggest, best, brightest and most comprehensive publication a happy CoCo ever had! Is there any wonder we get letters daily which praise **the Rainbow**, the magazine one reader calls "A Pot Of Gold" for his Color Computer?

**The Rainbow** features more programs, more information and more in-depth treatment of the TRS-80 Color, TDP System-100 and Dragon-32 computers than anyone else.

Each monthly issue is well over 200 pages and contains more than two dozen programs and 30 or more product reviews. And advertisements: **the Rainbow** is known as the medium for advertisers — which means it has a wealth of information about new products every month unavailable anywhere else! More than 120 companies advertise in its pages every month.

But what makes **the Rainbow** is its people. People like Bob Albrecht, the master teacher of computer programming. People like Don Inman, the world's finest computer graphics writer. People like Dick White, one of the most knowledgeable writers about BASIC going. Or Dennis Lewandowski, who has that certain knack of explaining assembly language to beginners! And award-winning Steve Blyn, **the Rainbow's** main educational columnist. These people, and others, visit you monthly through columns available only in **the Rainbow**.

Special programs on using **Spectrator**. An income tax reporting system. Complete Adventure games and Simulations. **The Rainbow's** unique **Scoreboard** of arcade games. A column on educationally-oriented LOGO. The world's first four-color computer magazine centerfold! And much, much more.

Join the thousands who have found **the Rainbow** to be the absolute necessity for their CoCo. With all this going for it, is it surprising that more than 95 percent of **the Rainbow's** subscribers renew their subscriptions? We're willing to bet that, a year from now, you'll be among them!

the Rainbow  
9529 U.S. Highway 42  
P.O. Box 209  
Prospect, KY 40059

## Get Your Very Own Pot O' Gold! Rainbow On Tape Tops Typing

Here's your chance to have a Pot O' Gold full of programs, articles and information about CoCo every month of the year! A subscription to **the Rainbow** is only \$22 and you won't miss a single chock-full issue.

As the premier magazine for the TRS-80 Color, TDP-100 and Dragon-32 computers, **the Rainbow** has more of everything — and greater variety, too. Do yourself and your CoCo a favor and subscribe to **the Rainbow** today!

We accept VISA, MasterCard and American Express. Non-U.S. rates higher. U.S. Currency only, please.

YES! Sign me up for a year (12 issues) of **the Rainbow**.

Name \_\_\_\_\_

Address \_\_\_\_\_

City \_\_\_\_\_ State \_\_\_\_\_ Zip \_\_\_\_\_

Payment Enclosed

Charge  VISA  MasterCard  American Express

Account Number \_\_\_\_\_ Interbank # (MC only) \_\_\_\_\_

Signature \_\_\_\_\_ Card Expiration Date \_\_\_\_\_

Subscriptions to **the Rainbow** are \$22 a year in the United States, Canadian and Mexican rate is U.S. \$29. Surface rate elsewhere U.S. \$57. Air mail U.S. \$85. All subscriptions begin with the current issue. Please allow 5-6 weeks for first copy.

Tired of spending all your valuable computer time typing in those long, but wonderful, **Rainbow** programs each month? Now there is **Rainbow On Tape** to help ease the pain.

Each month all the lengthy programs (over 20 lines) in **the Rainbow** can come to you ready-to-run, thanks to **Rainbow On Tape**. More than 20 programs every month in all! At \$60 per year — or \$6.50 a tape — it is the biggest bargain going.

Back issues are available beginning with April, 1982. And each month's tape will be sent to coincide with the arrival of your current month's issue of **the Rainbow**.

YES! Sign me up for the biggest bargain going . . . **Rainbow On Tape!**

A Full Year for \$60  A Month for \$6.50 (Specify Month \_\_\_\_\_)

Name \_\_\_\_\_

Address \_\_\_\_\_

City \_\_\_\_\_ State \_\_\_\_\_ Zip \_\_\_\_\_

Payment Enclosed

Charge  VISA  MasterCard  American Express

Account Number \_\_\_\_\_ Interbank # (MC only) \_\_\_\_\_

Signature \_\_\_\_\_ Card Expiration Date \_\_\_\_\_

Subscriptions to **Rainbow On Tape** are \$60 in the United States, U.S. \$70 in Canada and Mexico and U.S. \$85 in other countries. Non-U.S. orders for single issues add U.S. \$2 to cover additional postage. Duties are the responsibility of the purchaser.



JUST  
THE  
BEST

The **RAINBOW**  
THE COLOR COMPUTER MONTHLY MAGAZINE

It's called the *premier Color Computer magazine* for good reason. **The Rainbow** is the biggest, best, brightest and most comprehensive publication a happy CoCo ever had! Is there any wonder we get letters daily which praise **the Rainbow**, the magazine one reader calls "A Pot Of Gold" for his Color Computer?

**The Rainbow** features more programs, more information and more in-depth treatment of the TRS-80 Color, TDP System-100 and Dragon-32 computers than anyone else.

Each monthly issue is well over 200 pages and contains more than two dozen programs and 30 or more product reviews. And advertisements: **the Rainbow** is known as *the* medium for advertisers — which means it has a wealth of information about new products every month unavailable anywhere else! More than 120 companies advertise in its pages every month.

But what makes **the Rainbow** is its people. People like Bob Albrecht, the master teacher of computer programming. People like Don Inman, the world's finest computer graphics writer. People like Dick White, one of the most knowledgeable writers about BASIC going. Or Dennis Lewandowski, who has that certain knack of explaining assembly language to beginners. And award-winning Steve Blyn, **the Rainbow's** main educational columnist. These people, and others, visit you monthly through columns available only in **the Rainbow**.

Special programs on using *Spectaculator*. An income tax reporting system. Complete Adventure games and Simulations. *The Rainbow's* unique *Scoreboard* of arcade games. A column on educationally-oriented LOGO. The world's first four-color computer magazine centerfold! And much, much more.

Join the thousands who have found **the Rainbow** to be the absolute necessity for their CoCo. With all this going for it, is it surprising that more than 95 percent of **the Rainbow's** subscribers renew their subscriptions?

We're willing to bet that, a year from now, you'll be among them!

**the Rainbow**  
9529 U.S. Highway 42  
P.O. Box 209  
Prospect, KY 40059

**BUSINESS REPLY CARD**

First Class

PERMIT No. 1

Prospect, KY

POSTAGE WILL BE PAID BY ADDRESSEE

**RAINBOW**

P. O. Box 209

Prospect, KY 4005



NO POSTAGE  
NECESSARY  
IF MAILED  
IN THE  
UNITED STATES



**BUSINESS REPLY CARD**

First Class

PERMIT No. 1

Prospect, KY

POSTAGE WILL BE PAID BY ADDRESSEE

**RAINBOW**

P. O. Box 209

Prospect, KY 4005

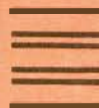

NO POSTAGE  
NECESSARY  
IF MAILED  
IN THE  
UNITED STATES



```

70 PRINT@1, "**** STATES AND CAPI
TALS ****"
80 PRINT@68, "THIS PROGRAM WILL T
EST YOUR KNOWLEDGE OF THE 50 ST
ATES AND CAPITALS. AFTER EACH ST
ATE (SELECTED AT RANDOM) TYPE IT
S CAPITAL FOLLOWED BY <ENTER>"
90 N=0:C=0:W=0:X=0
100 N=N+1:IF N>10 THEN 260
110 I=RND(50)
120 IF X=I THEN GOTO110
130 X=I
140 Q=0
150 PRINT"":PRINT"      WHAT IS T
HE CAPITAL OF      ";A$(I);:INPU
T Z$
160 IF Z$=B$(I) THEN 190
170 PRINT"":PRINT" NOT CORRECT!.
..TRY AGAIN":W=W+1
180 Q=Q+1:IF Q>=2 THEN 370 ELSE
150
190 R=RND(5):C=C+1:PRINT""
200 IF R=1 THEN 210:IF R=2 THEN
290:IF R=3 THEN 230:IF R=4 THEN
240:IF R=5 THEN 250
210 PRINT" CORRECT...YOU'RE A GE
NIUS!!":GOTO100
220 PRINT" CORRECT...YOU'RE EXCE
PTIONAL!!":GOTO100
230 PRINT" CORRECT...AMAZING ABI
LITY!!":GOTO100
240 PRINT" CORRECT...YOU'RE TOO
MUCH!!":GOTO100
250 PRINT" RIGHT ON...CARRY ON!!
":GOTO100
260 T=C+W
270 CLS:PRINT@6, "**** YOUR SCORE
****"
280 PRINT@64, C; "CORRECT"; W; "WRON
G"; " GRADE"INT(C/T*100);
290 PRINT"% "
300 PRINT@290, "DO YOU WISH TO CO
NTINUE":PRINT@ 325, "<ENTER> YES
OR NO":PRINT"":INPUT C$
310 CLS:IF C$="YES" THEN 90 ELSE
410
320 DATA MASSACHUSETTS, BOSTON, MA
INE, AUGUSTA, VERMONT, MONTPELIER, N
EVADA, CARSON CITY, NEW HAMPSHIRE,
CONCORD, NEW YORK, ALBANY, NEW JERS
EY, TRENTON, CONNECTICUT, HARTFORD,
VIRGINIA, RICHMOND, WEST VIRGINIA,
CHARLESTON, MARYLAND, ANNAPOLIS, NO
RTH CAROLINA, RALEIGH
330 DATA SOUTH CAROLINA, COLUMBIA
, FLORIDA, TALLAHASSEE, GEORGIA, ATL
ANTA, ALABAMA, MONTGOMERY, ARKANSAS
, LITTLE ROCK, MISSISSIPPI, JACKSON
, WASHINGTON, OLYMPIA, NEW MEXICO, S
ANTA FE, NORTH DAKOTA, BISMARCK, SOU

```

```

TH DAKOTA, PIERRE, IDAHO, BOISE, ILL
INOIS, SPRINGFIELD
340 DATA OHIO, COLUMBUS, INDIANA, I
NDIANAPOLIS, IOWA, DES MOINES, KANS
AS, TOPEKA, MISSOURI, JEFFERSON CIT
Y, OKLAHOMA, OKLAHOMA CITY, COLORAD
O, DENVER, UTAH, SALT LAKE CITY, HAW
AII, HONOLULU, ALASKA, JUNEAU, TEXAS
, AUSTIN, LOUISIANA, BATON ROUGE
350 DATA PENNSYLVANIA, HARRISBURG
, RHODE ISLAND, PROVIDENCE, WISCONS
IN, MADISON, MINNESOTA, ST PAUL, MIC
HIGAN, LANSING, KENTUCKY, FRANKFORT
, TENNESSEE, NASHVILLE, NEBRASKA, LI
NCOLN
360 DATA MONTANA, HELENA, WYOMING,
CHEYENNE, DELAWARE, DOVER, CALIFORN
IA, SACRAMENTO, OREGON, SALEM, ARIZO
NA, PHOENIX
370 PRINT"":PRINT"":PRINT" WELL,
I GUESS YOU REALLY DON'T      K
NOW IT!! (SHAME)"
380 PRINT"      THE CORRECT ANSWE
R IS      ";B$(I)
390 PRINT"":PRINT" NOW I WILL AS
K YOU AGAIN!"
400 GOTO140
410 END

```

## SP SOFTWARE

### FOUR NEW PROGRAMS FOR YOUR COLOR COMPUTER

**SPDUMP** A screen dump routine of 360 bytes of fast, relocatable machine language code. All PMODES, color PMODES in 4 B&W shades, twice size option in PMODES 3 or 4, position dump on paper, inverse image option, do more than 1 screen as for MPP graphics. Works on DMP200 LPVII etc. Comes with BASIC instructions. Needs BASIC1.1 or an 8bit printer fix. On tape. \$16

**CONCPOLY** Use this menu driven program to design and draw a fantastic variety of intricate and colorful patterns, suitable for dump to a printer. includes examples and instructions. Works in a 16K computer, EXT. or DISK BASIC. Comes on tape. \$8

**SIXFOURK** Use your 64K computer from BASIC. This program allows you to inspect RAM, move ROM to RAM and run it there, disable DISK or EXT. BASIC, and make setups with graphics, program, strings, and USR in upper or lower RAM to get the best use of RAM. The program does the setups and includes tutorials and instructions to let you make setups. On tape. \$20

**ROTORLD** This showy program for the 64K computer will display a rotating color globe of the earth. You get 20 frames of a PMODE1 globe which is loaded into 60K of RAM by a driver program plus an instruction program all on disk to show off your 64K color computer. \$25

Free little graphics program with order or request for our catalog. For fast service send check or MO to:

SP SOFTWARE, 1102 BILTMORE, LYNCHBURG VA 24502



## CoCo Cabinet: Compact, Compatible

By Curtis J. Bauter



*To the question of how to have organization hold sway over the chaos which can develop from the accumulated accoutrement of the avid computerist, one man's answer is to be found in a piece of custom-built furniture.*

My prime concern was a place to keep everything together and yet have a compact piece of furniture when CoCo was not in use.

As you can see, it's built on the lines of a standard kneehole desk with a couple of important differences. The overall dimensions are 38" L, 20" W, and 33" H. The "drawer" that the computer sits on is 25" from the floor (including casters), allowing plenty of space to sit comfortably. The drawer itself measures 16½" deep by 18½" wide which is wide enough to insert ROM Packs with no trouble. The additional height that this desk has keeps the monitor and CTR-80A at a very comfortable viewing angle. With the aid of the attached light, material on the top slide is easily read and the three drawers below are holding (so far) all the manuals, tapes, papers, and magazines that accumulate. The frame was made from oak (for extra weight and stability) and covered in half-inch thick plywood. The computer drawer is supported by a "full extension drawer slide" with a 50-pound load capacity when extended.

Cables from the computer go through a hole in the back of the drawer to a matching hole in the rear of the desk. A power outlet is located on the backside of the desk and is controlled by a single switch located inside the left front leg.

This is a fairly easy desk to make and the dimensions can be readily changed to suit your own needs.

### POWERBYTE SOFTWARE™

Presents

### APPLICATION SOFTWARE

### Business and Home

for the

### • TRS 80 Color Computer

### • TDP-100 Computer

65 Applications Available including:

THE ACCOUNTANT - General Ledger, Income Statement & Balance Sheet		\$29.95
ACCOUNTS RECEIVABLE/PAYABLE - Create Journal for Current Accounts & Record of Paid Accts.		\$21.95
BUSINESS INVENTORY	\$19.95	AT HOME INVENTORY \$12.95
ORDER TRACKER	\$19.95	CHECKBOOK BOOKY \$12.95
MY PROFIT MARGIN	\$16.95	THE STOCK TICKER \$16.95
BILLING SOLVER	\$19.95	TAPE
CASH FLOW MODEL	\$16.95	UTILITY BILL SAVER \$12.95
THE CLIENT TICKLER	\$19.95	THE BAR CHART \$8.95
INCOME & EXPENSER	\$15.95	MOTHER'S RECIPES \$12.95
BUSINESS	\$16.95	THE MAILMAN \$12.95
APPOINTMENTS		GRADE MY KIDS \$15.95

AND MANY, MANY MORE!!

ALL PROGRAMS FOR CASSETTE & GUARANTEED TO LOAD

### • FREE CATALOG

WITH INTRODUCTORY SPECIALS

### POWERBYTE SOFTWARE



2 CHIPLEY RUN  
WEST BERLIN, NJ 08091  
(609) 346-3063



# Turn your color computer on to the power of FLEX

NOW FROM THE WORLDS LARGEST SUPPLIER OF SOFTWARE FOR FLEX  
COMES FHL COLOR FLEX. JUST LOOK AT THESE FEATURES:

**IF YOU'RE TIRED OF  
NO DISK SOFTWARE,  
THEN FHL Color FLEX  
IS THE ANSWER!**

FLEX is the world's most popular operating system for the 6809 and with over 150 programs, we are the largest supplier of software for FLEX. These programs are NOT games but serious programs for your Color Computer. They range from word processors thru business applications to software development tools. Many Fortune 500 companies use our software. FHL Color FLEX turns your Color computer into a powerful system more capable than systems costing several times as much.

See our NEW 32 page catalog in the Jan.'83 issue of COLOR COMPUTER NEWS featuring over 150 products for FLEX, or send \$3.00 to us and we will see that you receive a copy!!

## **FLEX NOW ONLY \$99**

- NEW - "Tiny Editor"
- NEW - Interactive Assembler (Tiny ASM)
- NEW - Machine Language Monitor
- NEW - Video attributes include status lines, protected lines, and inverse video
- Hi-Res screen formats
  - 16 x 32 and 24 x 51, upper and lower case characters
  - 24 x 64 and 32 x 64 upper case
- Full ASCII keyboards
- Easy start-up—just type "FLEX"
- On-line assistance—Just type HELP
- Optionally use a standard terminal and printer
- Advance disk I/O and terminal capabilities - Supporting 35, 40, and 80 track single or double sided, single or double density drives
- No additional hardware required
- We have supported FLEX with more than any one else in the world for more than two years!

## **SPECIAL**

1. DBASIC, RS Disk Basic under FLEX with a utility to copy RS to FLEX disk \$30.
2. ED/ASM, line and screen editor with conditional macro assembler, both more powerful than TSC's and at the same cost, only \$100.
3. COLOR UTILITIES, a set of 12 utilities especially designed for FHL COLOR FLEX \$50.



THE REGENCY TOWER  
770 JAMES ST. . SYRACUSE, NY 13203  
TELEX 646740 . (315) 474-7856

**FHL** FRANK  
HOGG  
LABORATORY

\*FLEX is a trademark of Technical Systems Consultants Inc.





1. Here is Jeri plugging The Solution into the CoCo. Then she will move the main case up close to the CoCo. The cable is kept short to prevent noise and interference. The disk controller can be plugged into the side slot. The power supply plugs into a socket on the back of the case. All wires for the internal boards exit out the back of the case.



2. Here Jeri is setting the dip switches in The Solution. The hinged top makes the job easy. The switches can be set for three different things. Up to four boards can be installed inside the case.



3. Here is The Solution at work. It makes a very nice addition to your CoCo with a black anodized top and a silver anodized main case both made from heavy aluminum stock.

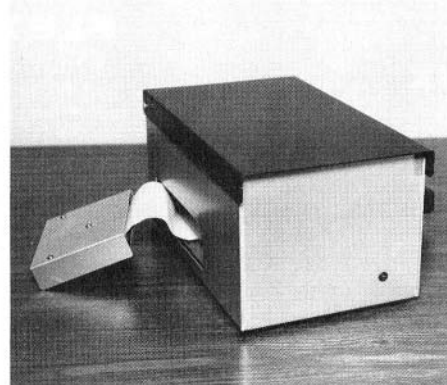

4. Here's The Solution all by itself. The heavy aluminum anodized case is a thing to be proud of. The buffer board can be seen to the left of the main case. The LED indicator on the front comes on when you turn on the power to your CoCo. The Solution needs no on/off switch.

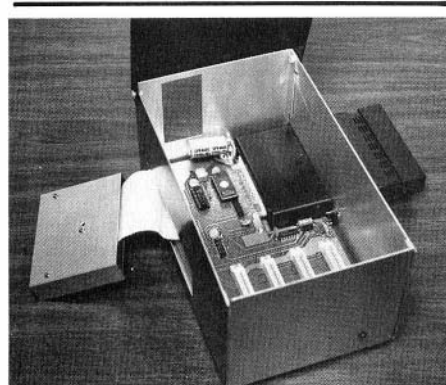

5. All that's missing from this picture is the plug in the wall power supply. You can see the 4K EPROM monitor and the 4 position dip switch. At the front are four of the five expansion slots with a disk controller plugged into the fifth slot on the side. The power LED is at the lower right front of the case.

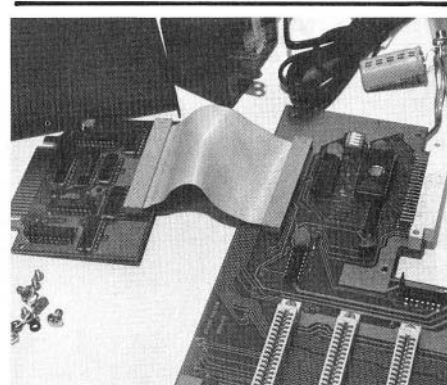

6. Here's the real guts to The Solution. We took it all apart so that you could look at the parts. The 1 amp power supply can be seen in this picture. All the connectors are gold as you would expect. The small board is the buffer board. The white connectors are the same as the CoCo's.

## THE SOLUTION AND WHY WE BUILT IT

When we first introduced FLEX for the CoCo in February 1982 we received hundreds of calls from software and hardware developers who wanted to use the CoCo because it was so inexpensive compared to everything else on the market. However there is not enough expansion or I/O in the CoCo to make this possible for most of these users. I know that the CoCo is viable in most cases, but for many, there needed to be more. So that was the original reason for designing the expansion box we call "THE SOLUTION."

The motherboard has the 2K/4K EPROM socket with a 4K monitor EPROM in it. Also inside are 4 vertical connectors for internally mounted boards or ROM type cartridges. The fifth connector is horizontal and is made for the disk controller, ROM cartridges or additional expansion out the side the of The Solution. A four position dip switch allows for 3 options to be selected. One option will cause the CoCo to get its interrupt and reset vectors from the monitor instead of RS Basic.

If you choose to come up in the monitor, then it is not necessary to have RS Extended Basic in the CoCo to boot FLEX because the monitor has a built-in boot. This saves \$100.00 of the cost of The Solution. The power supply is a plug-in-the-wall type with a connector in the back of the case. The back of the case is open and it is thru this that all the cables for the different cards go. This makes for a very neat appearance.

## TECHNICAL SPECIFICATIONS

**Bus Structure...** Fully buffered Color Computer compatible bus. Priority daisy chained arrangement where each slot has a priority assigned to it. The farther out on the bus that you are, the less priority you have. The disk slot (0) has the highest priority with slot 1, 2, 3, and then 4 has the lowest. The pinout and the timing is the same as the Color Computers with the exception of the sound line. This is used on the motherboard for the priority line.

**Power Supply...** The power supply is a tracking power supply which means that the Color Computer itself turns The Solution on and off so that there is no need for an on/off switch. A LED on the front of The Solution indicates when the entire system is on or off. The tracking power supply means that The Solution's bus voltage will be the same as the Color Computers to within a very few millivolts. The power supply included with The Solution is a 1 amp supply for the 5 volt line only. The +12 and -12 voltages are taken from the Color Computer.

### Dip switch options...

1) Select the 4K ROM monitor. When this option is selected, the system will come up in the monitor and get interrupt vectors from it rather than the Radio Shack Basic ROM. The reason you might want to do this is so you can boot FLEX from the monitor rather than Basic. This will allow running FLEX without have to have Extended Color Basic in the CoCo. This also ties in with the option on the serial card to come up on a terminal instead of the CoCo TV set and keyboard.

2) Disable the disk slot (0). This will allow using ROM cartridges in The Solution without unplugging the disk card. When the switch is on, the ROM is active. When it is off, whatever ROM cartridge is there is active. This infers that you could switch back and forth between a cartridge and the disk system. This is NOT necessarily true because of the need to initialize the disk software in the ROM and this may destroy what is in memory. It may be possible under special circumstances to do this but it is up to the user to work it out.

3) Select either a 2K or a 4K EPROM. This is set for a 4K EPROM which is included with The Solution. However, it can be changed if you have a need. The EPROM is addressed at \$E000.

4) User definable. This means that we didn't use this switch for anything, but you can if you want, or we could call it 'reserved for future expansion.' This means that we don't have any use for it now, but we may in the future.

The Solution I/O cards are addressed at either the \$FF60-\$FFBF area OR the \$FE00-\$FEFF area.

These prices and specs are subject to change without notice. Call for confirmation.

**THE SOLUTION** **\$249.00**  
(Price includes case and power supply.)

**CARDS FOR THE SOLUTION**  
**DUAL SERIAL PORT** **\$130.00**  
Two 6551 ACIAs, programmable baud rates (110-19,200), full RS-232, DB-25 conn.

**CLOCK and PARALLEL PRINTER CARD** **\$110.00**  
OKI clock w/battery backup and 1 parallel output port

**PROTOTYPE Cards** **\$ 37.00**  
3 1/2 by 9 inch card

**EPROM/RAM Card** **\$ 90.00**  
Up to 16K ROM (2732) or 8K static RAM (6116). Each device individually addressed anywhere in memory

**EPROM programmer** **\$185.00**  
Program 2K, 4K or 8K EPROMS. Software included either on disk or on board ROM.

**TRIPLE PARALLEL I/O Card** **\$105.00**  
Two 6821's and one 6522 for parallel I/O.

Note: We are considering several other cards for The Solution. Please let us know what you want, if there is enough interest, we will make it.

**FHI FRANK HOGG LABORATORY**

THE REGENCY TOWER • 770 JAMES ST. • SYRACUSE, NY 13203 • TELEX 646740 • (315) 474-7856

# **YOU!**

**ARE CORDIALLY INVITED TO ATTEND**

**THE**

# **RAINBOWFEST**

**APRIL 22-24**

WE, AT FRANK HOGG LABORATORY WOULD LIKE TO INVITE YOU TO VISIT US AT THE UPCOMING **RAINBOWFEST**, APRIL 22-24 IN CHICAGO.

THIS IS THE FIRST SHOW EVER, TOTALLY DEVOTED TO THE COLOR COMPUTER!! IT PROMISES TO BE INFORMATIVE, EDUCATIONAL, EYE-OPENING AND MOST OF ALL, **FUN!!!**

ALONG WITH MANY OF THE BIG NAMES IN THE COCO WORLD, WE WILL BE AVAILABLE TO GIVE YOU THE OPPORTUNITY TO VIEW OUR SOFTWARE AND HARDWARE, ASK QUESTIONS, MEET THE PEOPLE YOU'VE BEEN DEALING WITH, AND MORE OR LESS SATISFY YOUR CURIOSITY.

SO, IF YOU ARE AT ALL INTERESTED IN THE COLOR COMPUTER AND WHAT IT CAN DO FOR YOU, COME AND SEE US AT THE **RAINBOWFEST!!** WE LOOK FORWARD TO SEEING YOU!!

**FHI** **FRANK**  
**HOGG**  
**LABORATORY**

THE REGENCY TOWER • SUITE 215 • 770 JAMES ST. • SYRACUSE, NY 13203  
PHONE (315) 474-7856 • TELEX 646740



## So So, Señor

Buenos dias. Me llamo Barbara. Donde esta un programme satisfactorio?

That is what I was asking when I concluded working through *Spanish One*, a beginner's program for "learning elements of the Spanish language," created by the West Bay Company of White Stone, Virginia.

Its introduction says that by using this program, one can "quickly ... learn to read and speak Spanish," and that it is for "beginners or those persons needing to refresh their memory." The program offers "100 useful words and 100 useful phrases."

A person using *Spanish One* should not expect to "learn" the Spanish language. He/she will learn some vocabulary and even some pronunciation. A fairly creative attempt to imitate through phonetic representation the sound of the language has been made. However, one must learn elsewhere the sophisticated sounds or vocabulary intricacies of the Spanish language.

Moreover, the vocabulary words chosen for study include words seldom used in ordinary conversation, such as "ceiling," "handkerchief," "stocking," "jacket," and "box."

Teachers hoping to use this program to supplement classwork will be dismayed at the number of its inadequacies. First of all, the basic idea of gender (masculine and feminine endings) is poorly handled. Occasional lack of information in the questions penalizes the student who answers "estrecho" for "narrow" if the feminine "estrecha" was the programmed response. If a score were kept, the

ultimate score could be devastating.

Sound cues are offered to identify right and wrong answers, but perhaps the creator should have used Spanish terminology to applaud or admonish responses, rather than English.

Another basic part of "mastering" Espanol is keeping track of articles which precede nouns. Gender does sometimes make a difference for understanding. The handling of this, too, is inconsistent.

Could West Bay have come up with a way to provide synonyms alongside the preferred response so that the student would not become so discouraged or even angry? If the response one types in is close, somehow he/she should be rewarded for that. If "*Spanish One*" is for beginners, okay, they won't know any better, maybe. But students "refreshing their memory of the language" will be quickly alienated.

In addition, the programmer has been careless in the presentation of verbs. Inconsistencies frustrate the student. One time the subject pronoun is required; at other times, just the verb is acceptable. And one also "misses" if his/her English verb for "toma," for example, is "is taking" instead of "takes." Both are actually acceptable and, out of context, the student doesn't know which to give.

Other knowledge of Spanish verbs is required (but not taught here), for example with regard to the verb "to be." How does the user of this program learn the difference between "es" and "esta" for "it is"? Or the subtleties of choosing between familiar or formal verbs?

Another annoyance is the inconsistency in punctuation. Occasionally abbreviations or statements will be punctuated, but often they are not. And the student must hope her/his response is "lucky" enough to be punctuated just so, or—Bingo—another "wrong" answer.

(The program's notes contain a disclaimer that standard diacritical marks, such as inverted punctuation marks or the tilde, cannot be shown on their computer. Some compensation is made for this in the phonetic spelling.)

As an English teacher with a minor in Spanish, I strongly object to errors in plain, old grammar. The creator's statement "That is between you and me" translates "El esta entre usted y yo." "Yo" is the pronoun for "I," an error which only serves to perpetuate a common error in our own sloppy use of English.

There are other ambiguities in the program, but one glaring error is inconsistency in spelling of vocabulary words. Early on I learned that "corbata" means "tie" only to be marked wrong later when the required response was "cobata." This carelessness is inexcusable.

The program has its merits. For starters, one can choose between English words to be translated into Spanish words or vice versa. Likewise, one can practice translating phrases from one language to the other. Repetition is a second plus as one is randomly called upon to repeat responses so eventually they are learned. Also, the program notes describe a method of extending the time a word is on the screen so one can "study" it. Finally, the phonetic representation is helpful in learning pronunciation.

West Bay concludes the notes by touting this is a "good program. Enjoy!" The program is fairly entertaining and the price is very reasonable, but the Spanish wouldn't get you very far in South America. (Translation of opening paragraph: "Hello. My name is Barbara. Where is a satisfactory program?") Hasta luego!

(West Bay Company, Route 1, Box 666, White Stone, VA 22578, \$8 on tape)

—Barbara Combes

Color  
Computer  
Flex\*  
OS-9†  
Users  
Move  
up to  
C  
Language

DO YOU WANT faster running programs (over 100 times faster than BASIC)? A high level language that is also a low level language? A compiler that runs in less than 32K? Assembly language output? Position independent code? Extensive library functions in source assembly code? Periodic newsletters with new library functions? An aid in learning assembly language? Liberal version updates?

C IS DESTINED to become the language of the eighties: A compact, highly versatile, easy to use language, excellent to use to build games, applications, utilities, operating systems, etc.

DUGGER'S GROWING SYSTEMS with over 21 years of experience in computing was first on the market with a 6809 C compiler. The compiler has been extensively tested, revised, and proven.

DUGGER'S GROWING SYSTEMS C is a growing subset of the standard C. Version 1 contains all the necessary C commands (while, if, if else, int, char, etc.). Version 2 contains additional features (float, long, for, goto, etc.).

AN EXTENSIVE LIBRARY in assembly language source is provided (char, I/O, formatted print, file handling, string manipulating, etc.) TRS DOS version also has additional functions which use the BASIC ROM functions (CLS, POLCAT, floating point, draw, etc.).

**ORDER NOW**  
(new low prices)

TRS DOS C Version 1.2 (disk version) . . . . .	\$49.95
Computerware disk assembler . . . . .	49.95
Computerware Scribe (Editor-text formatter) . . . . .	49.95
Order all three and save \$10 . . . . .	139.95
C Programming Language by Kernighan & Ritchie (a must) . . . . .	17.95
OS-9 C Version 1.2 . . . . .	95.00
Flex OS-9* C Version 2.3 . . . . .	120.00
C.O.D. & Foreign handling add 15%	
MasterCard and Visa accepted.	

**DUGGER'S GROWING SYSTEMS**

Post Office Box 305  
Solana Beach, California 92075  
(619) 755-4373

\*OS-9 is a trademark of Microware, Inc.  
†FLEX is a trademark of Technical Systems Consultants, Inc.

# Searching for Service? It's Here.

Color Computer

TRS-80  
HARDWARE & SOFTWARE

Model III

## 13% OFF

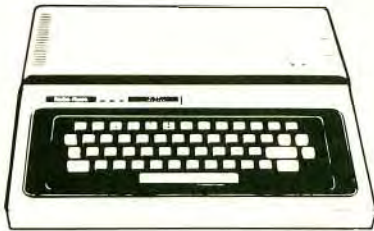

**13% OFF LIST PRICE**



**13% OFF LIST PRICE**

### FEATURING THESE ITEMS:

VERBATIM DISKS.....	\$27.95
ELEPHANT DISKS.....	\$25.00
WICO COMMAND CONTROL JOYSTICK.....	\$29.95
WICO COMMAND CONTROL ADAPTER.....	\$19.95

### ALSO SOFTWARE BY:

SPECTRAL ASSOCIATES • MARK DATA  
PRICKLY PEAR • TOM MIX • ANTECO

**TOLL FREE  
1-800-251-5008**



P. O. BOX 897  
GILSVILLE FAMILY CENTER  
SMYRNA, TENNESSEE 37167  
615-459-2636  
NASHVILLE, TENNESSEE 254-0088





## Kamikaze Is Good Arcade/Adventure Hybrid

Most computer games, in my experience, seem to fall into two categories. There are the arcade games, which are basically tests of hand-eye coordination and quick reflexes, and there are adventure games, which require a bit of thinking, but frequently become overly long and frustrating to play.

So it's refreshing to run into that rare game that doesn't fit into either mold. Such a game is *Kamikaze*.

Like an adventure, *Kamikaze* requires a bit of strategy, and a good measure of luck. Like an arcade game, *Kamikaze* makes good use of CoCo's graphics capabilities to illustrate the playing field and the battles.

As the documentation states—and one should always begin by reading the documentation, of course—“*Kamikaze* is a naval battle game depicting a Midway-type encounter between American and Japanese forces at the close of WWII. Player controls the American force of 12 ships and 78 planes and must destroy the Japanese fleet before it and more than 25 kamikaze squadrons find and destroy him.”

The 12 ships are divided among aircraft carriers, battle-ships, heavy and light cruisers, and destroyers. They vary in their ability to attack and to withstand enemy fire.

There are several different screens that appear during the course of the game. The text screens—“Bridge,” “Flag,” “Target,” and “Intelligence”—provide the data you will need during the strategy and the combat. The Map screen graphically shows your location, and the location of enemy planes and ships that you will be able to spot using radar,

search planes, and picket boats.

When you spot the enemy—or when the Japanese fleet sneaks up on you—there are several kinds of battles which may result.

The most graphic battle is a kamikaze attack, which you may choose to fight with a joystick or refuse the joystick (in which case your ship will fire at random on the invading Japanese dive bombers.)

After playing one game without the joystick—which had the effect of making me a spectator at the battle rather than a participant—I found I preferred to do my own shooting. It may look easy—but you'll be surprised! As author Phil Keller explains in the instruction sheet, he has programmed in a “random miss factor.” (By the way, the documentation contains several such insights into the programming of the game. More on that in a moment.)

Another battle is planes against planes. This one isn't quite so graphic—just a line-up of yours on one side and theirs on the other. Shots are fired at random.

If your aircraft are ready—and about half the time they won't be—when the enemy fleet is in range, then you can attack their ships with dive bombers and torpedo bombers. You'll have to place the planes over the battle area in the best strategic locations.

Unfortunately, the most decisive battle is not graphic at all. The object of the game is, as noted earlier, the destruction of the enemy's fleet. When their fleet invades your space, you will be engaged, like it or not, in a surface battle. What you see looks something like a news wire: “Carrier Seminole hit—sinking ... enemy ship hit ... miss ... miss...” etc. Your only choice is to stay and fight or try an escape, which may or may not be successful.

Time of the game is divided into eight “days” with four turns per day. At the end of that time, you will have one of five ratings which range from “disastrous defeat” to “decisive victory.”

With regard to the documentation, on the whole it seems well-written, but the game is not easy to master. (That's all to the good—you won't get bored with it right away.) There are a large number of commands and screens and situations to learn, and it will take at least three games to really get into it.

In addition to six pages of instructions, Mr. Keller has included two pages of programming notes. He offers a couple of tips on strategy, tells where to put in a speed poke if you want one, and even goes into detail as to how he made use of the *GET* and *PUT* commands to animate the destruction of the kamikazes.

The game requires 32K and Extended Basic.

(Ark Royal Games, P.O. Box 14806, Jacksonville, FL 32238, \$24.95)

—Neil Edward Parks

Hint . . .

### Speed Up Your CoCo

You can double the speed at which CoCo operates with a simple POKE statement, entered either directly from the keyboard or within a program. The statement is POKE 65495,0. This will speed up your CPU. You can return the computer to normal speed again by POKE 65494,0.

Note that you cannot perform any Input/Output operations, such as saving the program to cassette, when the speedup is in effect. You may also lose temporary keyboard control. If this happens, a simple press of the RESET button will bring things back to normal, too.

**Aurora  
Software**

49 BROOKLAND AVE  
AURORA ONTARIO  
CANADA L4G 2H6

#### FAMILY GAMES

For 16K AND 32K COLOR COMPUTER

**STOCKBROKER**—Up to 6 players can play the stock market. For 16K or 32K ECB. The 32K is in High-Res Graphics. **COLORMIND**—Up to 4 players challenge for hidden colors. **CRIBBAGE**—For 2 or 4 players. In High-Res Graphics! (for 32K). **CONCEN**—Challenge the computer or a friend to a good ol' game of concentration. **REMREM**—Challenge your friends. Who can remember the longest color sequence?

**BATTLE**—Will you get bombed before you can find all the ships? An extremely entertaining game for the family.

ALL GAMES ONLY \$20.00 OR ANY TWO FOR \$35.00  
ALSO FROM AURORA SOFTWARE

**MR.COPY**—A quality copier written in M.L. that will make backup tape copies. MR.COPY is capable of making up to 99 copies in one loading! \$25.00

**ROMDISK**—If you have a modified 32K C.C. machine \$20.00 ROMDISK will allow you to load your R.S. Rom Packs from a disk! \$20.00



# PRICKLY-PEAR SOFTWARE

## QUALITY PROGRAMS FOR YOUR COCO & TDP-100

PROGRAMS REQUIRE 16K EXTENDED BASIC FOR TAPE, AND 32K DISK UNLESS OTHERWISE NOTED.



### Flight

If you'd like to fly a plane then this is what you've been waiting for. A really good graphics oriented flight simulator in high resolution. Four difficulty levels let you go from student level to a difficult instrument-only landing. In front of you on the screen are your instruments, and above them are two representations of your plane in relation to the flight path (top and side views). At the higher levels all you have to go by are the instruments. Can you put it down on the runway to hear the synthesized voice from the tower say "perfect landing"? It's tough! You use your joystick just like the control stick on a plane, and the action is realistic indeed. This program was written by a professional flyer — a pilot for a major United States air carrier, and the high standards of professionalism really show. Just CLOADM and take to the skies!! Requires 32K extended. TAPE is \$19.95 — DISK is \$24.95

### A Partial List of Prickly-Pear Programs

Astrology, Gangbusters, Household Helper, Fantasy Gamer's Package, Viking, Football, Preread I, II & III, Mathpac I, Tarot, I Ching, Numerology, The Great Word Game, The 80C Songbook, Phonics 1, Phonics 2, Flight, Las Vegas Weekend, The 8-Bit Bartender, The Fantasy Master's Secretary, Monsters & Magic, Topsy Turvy, Galactic Patrol, Blockade, Sea Wars, Jungle, Spanish . . .

If you are running a disk system, we suggest that you order the disk version, because the cassette version will not run on a disk system without modification or disconnection of the disk controller. The above disk programs require 32K Ram.



Your Personal check is welcome - no delay. Include \$1.50 shipping for each program ordered. (Shipping free on \$50.00 or larger orders). Az. residents add 6% sales tax. Orders shipped within two days.

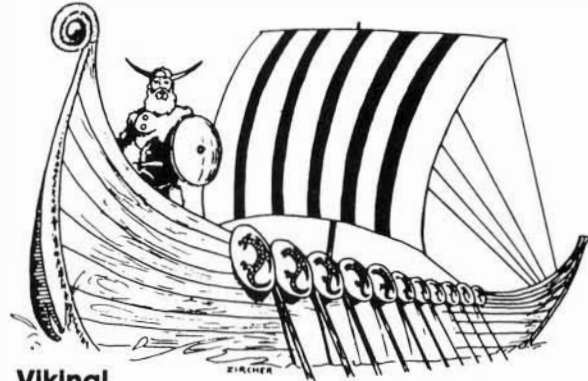

### Viking!

A simulation for 1 to 4 persons. Each begins as a land-owner, and by farming their land, buying and selling land, expanding their fishing fleet, building on to their manufactory, increasing their population, equipping and training more soldiers, and regulating their taxes, each player tries to increase their economic power and rank until one becomes ruler over all. But beware plagues, rats, raiders, revolts, bad weather, and other misfortunes which may lie along the road to success. As you progress, see the map of your holdings increase. Playable in 1 to 2 hours, and different every time, you may have an addiction problem. \$19.95 tape — \$24.95 disk



### Gangbusters

If you ever wanted to try a life of crime, this is your chance. You will start out as a Punk, but by using brains, and a little muscle, you can rise to become a Hood, Runner, Bookie, Torpedo, Fence, Kingpin, or win by becoming Syndicate Boss. Indulge yourself. Bribe a judge, or the District Attorney. Pay off the Cops. Take out a contract on another player, but watch out, they may be after you. Buy trucking companies, bootleg operations, houses of ill fame, but remember, if you get caught, you may do some hard time. Do you have what it takes to take over? This game will keep you close to your rod, get you thinking about bulletproof glass in your car, and definitely bring out the worst in you, but you'll love every minute of it. For 2 to 6 players, takes about 2 hours to play. Every game is excitingly different. \$19.95 tape — \$24.95 disk

Stocked by Quality Dealers, or

Send Order To: **PRICKLY-PEAR SOFTWARE**  
9822 E. Stella Road  
Tucson, Arizona 85730  
(602) 886-1505



# The Multi-Talented, Dancing *RAINBUG*

By  
Dan Downard

(This month's article by Dan Downard is the first of a four-part series on our new machine language monitor being developed by the author.)

What is a monitor? How does an assembler work? What do they do? These are probably the most confusing issues that face the beginning computer owner. Everyone talks about machine language programs, but what are the advantages, and disadvantages, of assembly language programs? Hopefully, in the next few issues, we will clarify these questions and give you the necessary tools to write your own programs. Where should we start? First, let us define some terms.

## Machine Language

The 6809 microprocessor inside the CoCo follows a logical sequence of operations as it steps through memory. Program information in memory tells the processor what step to take next. This information in memory is coded in sequential order and the processor reads these instructions and performs the operation requested. Normally, we like to refer to the bytes of instructions as operational codes, or op-codes. By learning what op-codes are available and how to use them we can make the processor input and output data display information on the screen or interface with various peripheral devices. Machine language is the only language the computer can understand. The Extended Color BASIC ROM in your computer is actually a machine language program that converts BASIC keywords and statements in memory to machine codes. This type of program is called an Interpreter. Programs that can directly input machine code into memory are called *monitor* or *debug* programs. These programs are very important tools for the machine language programmer.

## Assembly Language

Motorola developed a set of mnemonic symbols to represent all of the microprocessor instructions. Instead of remembering 256 possible numbers representing instructions, each set of operations is given a mnemonic code and a structured set of symbols to represent the addressing mode. These codes are written as a text file representing the sequen-



tial operation of the processor. A program called an *assembler* is used to translate this file into machine code.

Why are most of these programs called *editor-assemblers*? The *editor* gives you the proper software to write your text file and is thereby a natural companion to the *assembler*. Programs are also available to convert machine language to assembly language. These programs are normally referred to as a *dissassembler*.

## Assembler vs. Machine Code

Essentially, there is no difference between machine language and assembly language. Both are designed to serve the same end purpose. In terms of operating programs, a monitor would be used to modify or "Debug" an existing program. An assembler would be used to develop new programs.

The easiest way to understand machine language programming is to try to modify a program to suit your own needs. After all, you can look through the ads in this issue and likely find something similar to what you want to accomplish. What about the programs with listings in the magazine? How do you input a machine language program into memory? I find it very tedious to convert all of the hexadecimal instructions into decimal poke statements. With a monitor, all you have to do is input the hex numbers exactly as they appear.

At the same time, why use machine language at all? What's wrong with Extended Color BASIC? Well, I guess there is no standard answer to that question other than another question. Will BASIC do everything you want it to do?

To paraphrase *Getting Started With Color BASIC*, machine language programs are very fast and require less memory than a BASIC program. To give you an example, did you know that your TRS-80C executes instructions at the rate of approximately 200,000 per second? Why not take advantage of it?

## Monitors

There are several excellent machine language monitor programs on the market. *Table 1* is a comparison of several of the more popular offerings. To me, the prerequisites of a monitor are memory examine/change, tape loading and

saving of programs, register examine/change and breakpoints. What is a breakpoint? A breakpoint is a method of interrupting a program during operation to examine registers, memory, etc. to ensure that the program is operating properly.

### Monitor Program Comparison Chart

	<b>Zbug</b> <i>Radio Shack</i>	<b>Cbug</b> <i>Microworks</i>	<b>Colormon</b> <i>Tom Mix</i>	<b>Sigmon</b> <i>Datasoft</i>	<b>Humbug</b> <i>Star-Kits</i>
<b>Size</b>	Rom Pak	1.5K	1K	6K	4K
<b>Relocatable</b>	No	Yes	Yes	Yes	Yes
<b>Examine/Change Memory</b>					
<i>Hex</i>	Yes	Yes	Yes	Yes	Yes
<i>ASCII</i>	Yes	Yes	Yes	Yes	Yes
<i>Octal</i>	Yes	No	No	Yes	No
<i>Graphics</i>	No	Yes	No	Yes	No
<b>Execute Program</b>	Yes	Yes	Yes	Yes	Yes
<b>Tape</b>					
Load	Yes	No	No	Yes	No
Save	Yes	Yes	No	Yes	Yes
Verify	Yes	No	No	No	No
Mikbug Load/Save	No	Yes	No	Yes	Yes
<b>Breakpoint</b>					
Set/Reset	Yes	No	Yes	Yes	Yes
Display	Yes	No	No	Yes	Yes
Continue After BPoint	Yes	Yes	No	Yes	Yes
Single Step	Yes	No	No	Yes	Yes
Return To Basic	Yes	Yes	Yes	Yes	Yes
<b>Print/Change Registers</b>	Yes	Yes	Yes	Yes	Yes
<b>Disassemble</b>	Yes	No	No	Yes	Yes
<b>Assemble</b>	Yes	No	No	Yes	No
<b>Search Memory</b>	No	No	No	Yes	Yes
<b>Tape Analyzer</b>	No	No	No	No	Yes
<b>Change Baud Rate</b>	No	Yes	No	No	Yes
<b>Non-Standard Printer</b>	No	No	No	No	Yes
<b>Printer On/Off</b>	Yes	No	No	Yes	Yes
<b>Pause Listing</b>	No	No	No	Yes	Yes
<b>Dumb Terminal</b>	No	Yes	No	No	Yes
<b>Remote Terminal</b>	No	Yes	No	No	Yes
<b>Change Screen Page</b>	No	Yes	No	No	No
<b>Help Command</b>	No	No	No	No	Yes
<b>Move Memory</b>	Yes	Yes	No	Yes	Yes
<b>Move Monitor</b>	No	No	No	No	Yes
<b>Checksum</b>	No	No	No	No	Yes
<b>Memory Test</b>	No	No	No	No	Yes
<b>Memory Compare</b>	No	No	No	No	Yes
<b>Fill Memory</b>	No	Yes	No	No	Yes
<b>Hex/Dec Convert</b>	Yes	Yes	No	Yes	No
<b>Calculate Mode</b>	Yes	No	No	No	No



At the same time, breakpoints are used to isolate certain parts of the program for troubleshooting purposes.

Getting back to the table, one of the terms that may look unfamiliar is MIKBUG under tape features. MIKBUG was the original monitor for the 6800 computer written by Motorola. Tapes in a MIKBUG format were the standard for many early 6800 computers. This command gives you the facility of loading programs from tapes made by the SWTP, EXORCISER, etc. computers. There is a wealth of software already written, but undiscovered for the TRS-80C. I would recommend any of these programs depending on which features you desire. Consult the ads in the magazine for sources of supply. All of these monitors perform the basic functions as defined above. The only real difference is in the auxiliary functions.

## RAINBUG

In an effort to give you an insight into machine language programming, we are going to present a complete machine language monitor in the next four issues of *Rainbow*. It will affectionately be called *RAINBUG*. The Motorola ASSIST-09 monitor was used as a guideline as it was readily available and has features not contained in other monitors on the market. Features of *RAINBUG* are as follows:

- Memory Examine/Change
- Register Examine/Change
- Postbyte Calculation
- Breakpoints
- Offset Calculation
- Single Step
- Save to Tape
- Load Tape
- Verify Tape
- Expression Calculation
- Disk Memory Examine/Change

At the same time we hope to explain how to write your own programs or modify existing programs to suit your own needs. Since space is limited, reference material will be necessary. The MC6809-MC6809E Microprocessor Programming Manual is available from:

Motorola Semiconductor Products, Inc.  
Literature Distribution Center  
P.O. Box 20924  
Phoenix, AZ 85036

A request for technical information in the form of a letter will be sufficient. Motorola will then send you a catalog of technical information available and an order form.

## Memory Examine/Change

Listing 1 contains the assembly source code for the

# 64K for \$99!

We will convert any Radio Shack Color Computer to a full 64K for only \$99.00 plus shipping. (Compare this with RS price of \$149 + \$30 labor for 32K upgrade.) No matter what board you have — No matter what ROM you have — Typically 24 hour turn around — Includes hardware modification to access the entire 64K, with special software and instructions on use of the upper 32K. Pack your computer well. Include cashiers check, money order, or personal check (allow 2 weeks for personal checks) for \$104.00 (\$99.00 + \$5.00 shipping) to PYRAMID. You may pay also by Mastercharge or return COD. We will treat your computer tenderly and rush it back to you.

PYRAMID — 527 Hill St. — Santa Monica, CA — 90405 — (213) 399-2222

memory examine and change routine of *RAINBUG*. The formats are as follows:

M (Address) / Initiate memory/change at (Address).  
Address may be an expression.

(Address) / Initiate memory change at (Address). Address may not be an expression.

/ Memory/change at address of last memory/change.

After the present byte is displayed, the following commands can be entered:

(Byte) Replace present byte with new value. This value may be an expression.

(Space) Print value at next address.

(.) Go to next address without printing value.

(j) Print next address and byte value

(i) Print previous address and byte value.

(Enter) Terminate command.

(')TEXT(') Enter ASCII text.

If the memory is not changed, a question mark will appear and the next memory will be displayed. All addresses and memory values are displayed in hexadecimal notation.

## Expressions

Address and byte values may be in the form of an expression. Each expression consists of one or more values separated by a "+" or "-" operator, meaning addition or subtraction. For example entering (4000+2000) would give you an address of \$6000. This function is very useful when writing position independent code, etc.

## Summary

Next month, we will begin learning the terminology of mnemonics and their corresponding op-codes.

Hopefully, there will be enough information for both the beginner and experienced programmer to make it interesting. At the same time, we will present the initialization routines and command table for *RAINBUG*. I hope we are not getting ahead of ourselves by including this listing, but before you can input any machine code into the computer you have to have a monitor. The part of *RAINBUG* presented this month will run if you have the facility of inputting it into your computer. Once the machine codes are in memory perform a *CSAVEM "RAINBUG1",&H3000,&H319D,&H3000*. (An easier way would be to wait for your *Rainbow on Tape*.) After loading, type *EXEC* and the first address you wish to examine. If you accidentally exit the program, an *EXEC* will get you back.

## The listing:

```

00100 *RAINBUG-PART 1
00110 *DAN DOWNARD
3000      00120      ORG      $3000
          3006      00130 CMDBAD EQU      CMEM2
          008C      00140 SKIP2 EQU      $8C
          A000      00150 POLCAT EQU      $A000
          A002      00160 CHRQUT EQU      $A002
          00165 *MEMORY EXAMINE/CHANGE
3000 17 013C 00170 CMEM  LBSR  CDNUM
3003 FD 3197 00180 CMEMN STD  ADDR
3006 BE 3197 00190 CMEM2 LDX  ADDR
3009 17 0145 00200      LBSR  OUT2H
300C 86 2D   00210 LDA   **2D
300E 17 0169 00220      LBSR  OUTCH
3011 17 007F 00230 CMEM4 LBSR  BLDNNB

```

3014 27 0B	00240	BEQ	CMENUM	3049 26 0A	00480	BNE	CMNOTL
	00245 *COMMA-SKIP BYTE			304B 86 0D	00490	LDA	##0D
3016 81 2C	00250	CMPA	##2C	304D 17 012A	00500	LBSR	OUTCH
3018 26 10	00260	BNE	CMNOTC	3050 BF 3197	00510	STX	ADDR
301A BF 3197	00270	STX	ADDR	3053 20 0C	00520	BRA	CMPADP
301D 30 01	00280	LEAX	1,X		00525 *UP ARROW-PREVIOUS BYTE		
301F 20 F0	00290	BRA	CMEM4		00526 *WITH ADDRESS		
3021 F6 319A	00300	CMENUM	LDB	NUMBER+1	3055 81 5E	00530	CMNOTL
3024 8D 50	00310	BSR	MUPDAT	3057 26 0C	00540	BNE	CMNOTU
3026 81 2C	00320	CMPA	##2C	3059 30 1E	00550	LEAX	-2,X
3028 27 E7	00330	BEQ	CMEM4	305B BF 3197	00560	STX	ADDR
	00335 *ASCII STRING			305E 17 0122	00570	CMPADS	LBSR
302A 81 27	00340	CMNOTC	CMPA	##27	3061 8D 07	00580	CMPADP
302C 26 0D	00350	BNE	CMNOTQ	3063 20 A1	00590	BRA	CMEM2
302E 17 0107	00360	CMESTR	LBSR	READ		00595 *SLASH-NEXT BYTE	
3031 81 27	00370	CMPA	##27		00596 *WITH ADDRESS		
3033 27 0D	00380	BEQ	CMSPCE	3065 81 2F	00600	CMNOTU	CMPA
3035 1F 89	00390	TFR	A,B	3067 27 F5	00610	BEQ	CMPADS
3037 8D 3D	00400	BSR	MUPDAT	3069 39	00620	RTS	
3039 20 F3	00410	BRA	CMESTR		00625 *PRINT ADDRESS		
	00415 *SPACE-NEXT BYTE			306A BE 3197	00630	PRTADR	LDX
303B 81 20	00420	CMNOTQ	CMPA	##20	306D 34 10	00640	PSHS
303D 26 08	00430	BNE	CMNOTB	306F 30 E4	00650	LEAX	,S
303F BF 3197	00440	STX	ADDR	3071 17 00F2	00660	LBSR	OUT4HS
3042 17 0125	00450	CMSPCE	LBSR	SPACE	3074 35 90	00670	PULS
3045 20 BF	00460	BRA	CMEM2		00675 *UPDATE BYTE		PC,X
	00465 *DOWN ARROW-NEXT BYTE			3076 BE 3197	00680	MUPDAT	LDX
	00466 *WITH ADDRESS			3079 E7 80	00690	STB	,X+
3047 81 0A	00470	CMNOTB	CMPA	##0A	307B E1 1F	00700	CMPB
							-1,X

## PARALLEL PRINTER INTERFACE

FOR THE RADIO SHACK COLOR COMPUTER



- \* RUN ANY STANDARD PARALLEL PRINTER FROM THE COLOR COMPUTER SERIAL I/O PORT
- \* WORKS WITH : EPSON MX 70/80/100, NEC PC8023, CENTRONICS, C-itoh, OKIDATA, SMITH CORONA DAISY WHEEL, RADIO SHACK, OR ANY OTHER PRINTER WITH A STANDARD PARALLEL INPUT.
- \* SWITCH SELECTABLE BAUD RATES FROM 300 to 9600  
The Color Computer is capable of 9600 Baud -- Poke 150,1.  
Running at 9600 Baud greatly increases the printing speed of some printers.
- \* COMPLETE - ALL CABLES AND CONNECTORS INCLUDED
- \* PRICE : \$69 plus \$3 for shipping and handling. Michigan residents add 4% sales tax.

## BOTEK INSTRUMENTS

4949 HAMPSHIRE  
UTICA, MICHIGAN 48087  
313-739-2910

Dealer inquiries invited



307D 26 04	00710	BNE	MUPBAD	30EB 27 D5	01210	BEQ	EXPTDI
307F BF 3197	00720	STX	ADDR	30ED 5F	01220	CLR	BSR
3082 39	00730	RTS		30EE 20 CA	01230	BRA	EXPRTN
	00735	*UPDATE	BAD	30F0 8D 0B	01240	EXPSUB	BSR
3083 34 02	00740	MUPBAD	PSHS A	30F2 34 02	01250	PSHS	A
3085 86 3F	00750	LDA	##3F	30F4 FC 3199	01260	LDD	NUMBER
3087 17 00F0	00760	LBSR	OUTCH	30F7 40	01270	NEGA	
308A 35 82	00770	PULS	PC,A	30F8 50	01280	NEGB	
	00775	*SET WINDOW VALUE		30F9 82 00	01290	SBCA	#0
308C 17 00B0	00780	CWINDO	LBSR CDNUM	30FB 20 DF	01300	BRA	EXPADD
308F FD 319C	00790	STD	WINDOW		01305	*NEXT EXPRESSION	
3092 39	00800	RTS		30FD 8D 96	01310	EXPTRM	BSR BLDNUM
	00805	*EXPRESSION ANALYZER		30FF 27 36	01320	BEQ	CNVRTS
	00806	*NO LEADING BLANKS		3101 16 FF02	01330	BLDBAD	LBRA C MDBAD
3093 4F	00810	BLDNUM	CLRA		01335	*BUILD HEX BYTE	
3094 8C	00820	FCB	SKIP2	3104 7F 3199	01340	BLDHI	CLR NUMBER
	00825	*ACCEPT LEADING BLANKS		3107 7F 319A	01350	CLR	NUMBER+1
3095 86 20	00830	BLDNUM	LDA ##20	310A 8D 2C	01360	BLDHEX	BSR READ
3097 B7 319B	00840	STA	DELIM	310C 8D 13	01370	BLDHXC	BSR CNVHEX
309A 34 14	00850	EXP1	PSHS X,B	310E 26 27	01380	BNE	CNVRTS
309C 8D 66	00860	EXPDLM	BSR BLDHI	3110 C6 10	01390	LDB	#16
309E 27 1C	00870	BEQ	EXP2	3112 3D	01400	MUL	
	00875	*SKIP BLANKS		3113 86 04	01410	LDA	#4
30A0 B1 319B	00880	CMPA	DELIM	3115 58	01420	BLDSHF	ASLB
30A3 27 F7	00890	BEQ	EXPDLM	3116 79 319A	01430	ROL	NUMBER+1
	00895	*TEST FOR M,P OR W		3119 79 3199	01440	ROL	NUMBER
30A5 BE 3197	00900	LDX	ADDR	311C 4A	01450	DECA	
30A8 81 4D	00910	CMPA	##4D	311D 26 F6	01460	BNE	BLDSHF
30AA 27 18	00920	BEQ	EXPTDL	311F 20 14	01470	BRA	CNVOK
30AC BE 3195	00930	LDX	PCNTER		01475	*ASCII TO BINARY	
30AF 81 50	00940	CMPA	##50	3121 81 30	01480	CNVHEX	CMPA ##30
30B1 27 11	00950	BEQ	EXPTDL	3123 25 12	01490	BLO	CNVRTS
30B3 BE 319C	00960	LDX	WINDOW	3125 81 39	01500	CMPA	##39
30B6 81 57	00970	CMPA	##57	3127 2F 0A	01510	BLE	CNVGOT
30B8 27 0A	00980	BEQ	EXPTDL	3129 81 41	01520	CMPA	##41
30BA 35 94	00990	EXPRTN	PULS PC, X, B	312B 25 0A	01530	BLO	CNVRTS
	00995	*GET HEX NUMBER		312D 81 46	01540	CMPA	##46
30BC 8D 4C	01000	EXP2	BSR BLDHEX	312F 22 06	01550	BHI	CNVRTS
30BE 27 FC	01010	BEQ	EXP2	3131 80 07	01560	SUBA	#7
30C0 20 0C	01020	BRA	EXPCDL	3133 84 0F	01570	CNVGOT	ANDA ##0F
	01025	*STORE AND CHECK DELIMITER		3135 1A 04	01580	CNVOK	ORCC #4
30C2 AE 84	01030	EXPTDI	LDX ,X	3137 39	01590	CNVRTS	RTS
30C4 BF 3199	01040	EXPTDL	STX NUMBER		01595	*INPUT CHARACTER	
30C7 7D 319B	01050	TST	DELIM	3138 8D 34	01600	READ	BSR INCH
30CA 27 EE	01060	BEQ	EXPRTN	313A 81 03	01610	CMPA	##03
30CC 8D 6A	01070	BSR	READ	313C 27 C3	01620	BEQ	BLDBAD
	01075	*TEST FOR + OR -		313E 39	01630	RTS	
30CE BE 3199	01080	EXPCDL	LDX NUMBER		01635	*OBTAIN NUMBER	
30D1 81 2B	01090	CMPA	##2B	313F 17 FF53	01640	CDNUM	LBSR BLDNUM
30D3 26 10	01100	BNE	EXPCDM	3142 26 0A	01650	BNE	CDBADN
30D5 8D 26	01110	BSR	EXPTRM	3144 81 2F	01660	CMPA	##2F
30D7 34 02	01120	PSHS	A	3146 22 06	01670	BHI	CDBADN
30D9 FC 3199	01130	LDD	NUMBER	3148 81 0E	01680	CMPA	##0E
30DC 30 8B	01140	EXPADD	LEAX D,X	314A FC 3199	01690	LDD	NUMBER
30DE BF 3199	01150	STX	NUMBER	314D 39	01700	RTS	
30E1 35 02	01160	PULS	A	314E 16 FEB5	01710	CDBADN	LBRA C MDBAD
30E3 20 E9	01170	BRA	EXPCDL		01715	*OUTPUT BYTE IN HEX	
30E5 81 2D	01180	EXPCDM	CMPA ##2D	3151 A6 80	01720	OUT2H	LDA ,X+
30E7 27 07	01190	BEQ	EXPSUB	3153 34 06	01730	PSHS	D
30E9 81 40	01200	CMPA	##40	3155 C6 10	01740	LDB	#16

# COLORSOFT™ BUSINESS SOFTWARE

**AT LAST! BUSINESS SOFTWARE DESIGNED FOR THE COLOR COMPUTER**

- ★ MAKE YOUR COLOR COMPUTER A WORKING BUSINESS PARTNER ★
- ★ ALL PROGRAMS ARE MENU DRIVEN AND USER FRIENDLY ★
- ★ PROFESSIONALLY WRITTEN AND FULLY TESTED ★
- ★ AFTER-THE-SALE SUPPORT ★

**SMALL BUSINESS ACCOUNTING PACKAGE**...Ideally suited for any small business with up to \$1,000,000 in annual sales and 400 accounts receivable and 400 accounts payable. This package provides detailed record keeping on accounts receivable and payable, sales, purchase orders, and allows input and maintenance of payroll related data. Prepares balance sheet and income statement, aging reports, and displays a check register, a listing of sales by date, and a listing of individual purchase orders. Included are printer output options. The step-by-step user's manual and the user friendly, menu driven format makes this program package fast, efficient, and easy to use.  
**REQUIRES SINGLE DISK DRIVE (User's manual without program \$20).....\$149.95**

**DEPRECIATION**...Determines depreciation values for assets based upon the new accelerated cost recovery system (ACRS) and the alternate ACRS methods in addition to the conventional methods. Adjusts for placing assets in service during the year. Screen or printer output.....**\$22.95**

**LOAN ANALYSIS**...Evaluate cost of borrowing for capital investments or business expansion. Prints amortization schedules and allows user to determine loan status at any point in the term of a loan. Other options allow user to determine either principle, interest, payment, or term based upon input of any three. An auto loan option includes trade-in allowance and taxes. Screen or printer output.....**\$20.95**

**ANNUITY**...Determine future value of investments, present value of a future amount, compound interest, and amount of an individual retirement account (IRA). Screen or printer output.....**\$18.95**

**EXPENSE ACCOUNT DIARY**...Keeps a record of travel expenses for up to 25 trips per year. Performs file searches based upon cross-referencing of date of trip, city visited, hotel, or purpose of trip. Screen or printer output. An excellent program for the traveling businessman.....**\$15.95.**

**STOCK ANALYZER**...Reviewed in July 1982 RAINBOW. New version provides printer output and is disk compatible. Maintains a stock portfolio data base of multiple stocks. Can be used to track performance of sales personnel or similar applications. Features graphing of data to screen or printer along with analyses that includes projection of data trends ..... **\$21.95.**

---

INCLUDE \$2.25 HANDLING PER ORDER  
ALL PROGRAMS REQUIRE 16K EXT. BASIC  
CUSTOM PROGRAMMING SERVICES AVAILABLE  
WRITE FOR FREE CATALOG

---

**COLOR  
SOFTWARE  
SERVICES**

BUSINESS SOFTWARE DIV.  
P.O. BOX 1708, DEPT. R  
GREENVILLE, TEXAS 75401



DEALER INQUIRES INVITED

TELEPHONE ORDERS  
(214) 454-3674  
9-4 Monday-Saturday

VISA/MASTERCARD



```

3157 3D      01750      MUL
3158 8D  04    01760      BSR      OUTHX
315A 35  06    01770      PULS     D
315C 84  0F    01780      ANDA    $$$F
315E 8B  90    01790 OUTHX  ADDA    $$$90
3160 19      01800      DAA
3161 89  40    01810      ADCA    $$$40
3163 19      01820      DAA
3164 20  14    01830 SEND  BRA     OUTCH
                01835 *OUTPUT ADDRESS
3166 8D  E9    01840 OUT4HS BSR     OUT2H
                01845 *OUTPUT BYTE
3168 8D  E7    01850 OUT2HS BSR     OUT2H
                01855 *OUTPUT SPACE
316A 86  20    01860 SPACE LDA     $$20
316C 20  0C    01870      BRA     OUTCH
                01875 *KEYBOARD INPUT
316E 34  15    01880 INCH  PSHS   X,B,CC
3170 AD  9F A000 01890 INCH1 JSR    [POLCAT]
3174 27  FA    01900      BEQ     INCH1
3176 8D  02    01910      BSR     OUTCH
3178 35  95    01920      PULS   X,B,CC,PC
                01925 *OUTPUT TO SCREEN
317A 34  12    01930 OUTCH  PSHS   A,X
317C AD  9F A002 01940      JSR    [CHROUT]
3180 35  92    01950      PULS   A,X,PC
                01955 *SEND CR/LF
3182      04    01960 PCRLS  FCB    $04
                01965 *CR/LF AND STRING

```

```

3183 30  8C FC  01970 PCRLF  LEAX   PCRLS,PCR
3186 86  0D    01980 PDATA  LDA     $$$D
3188 8D  DA    01990      BSR     SEND
318A 86  0A    02000      LDA     $$$0A
                02005 *OUTPUT STRING
318C 8D  D6    02010 PDTLP  BSR     SEND
318E A6  80    02020 PDATA1 LDA     ,X+
3190 81  04    02030 CMPA   $$$04
3192 26  F8    02040      BNE   PDTLP
3194 39      02050      RTS
                02055 *VARIABLE STORAGE
3195      02060 PCNTER RMB   2
3197      02070 ADDR   RMB   2
3199      02080 NUMBER RMB   2
319B      02090 DELIM  RMB   1
319C      02100 WINDOW RMB   2
                02110      END
                00000 TOTAL ERRORS

```

Following is the listing accidentally omitted from "Smarts for a Dumb Terminal." The listing explains the operation of the Color Basic ROM routine.

**/BASIC ROM SCREEN PRINT**

```

A30A PSHS   X,B,A      SAVE REGS.
A30C LDX   $8B        PUT SCRPTR IN X-REG
A30E CMPA  $$$0B     BACKSPACE?
A310 BNE   $A31D     GO CHECK FOR CR
A312 CMPX  $$$400    BEGINNING OF SCREEN?
A315 BEQ   $A35D     RETURN IF YES
A317 LDA   $$$60     $60=SPACE
A319 STA   , -X      STORE SPACE&DEC SCRNPTR
A31B BRA   $A344     STORE SCRPTR&RETURN
A31D CMPA  $$$0D     CARRIAGE RETURN?
A31F BNE   $A32F     GO CHECK FOR SPACE
A321 LDX   $8B        PUT SCRPTR IN X-REG
A323 LDA   $$$60     A=SPACE
A325 STA   , X+     STORE&INC X-REG
A327 TFR   X,D      PUT SCRPTR IN X-REG
A329 BIT   $$$1F     END OF LINE?
A32B BNE   $A323    AGAIN UNTIL DONE
A32D BRA   $A344     STORE SCRPTR&RETURN
A32F CMPA  $$$20     CONTROL CHAR?
A331 BLO   A35D     RETURN IF YES
A333 TSTA  BMI       GREATER THAN $80?
A334 BMI   $A342     STORE ON SCREEN
A336 CMPA  $$$40     NUMBER OR LETTER?
A338 BLO   $A340     BRANCH IF CHAR
A33A CMPA  $$$60     UPPER OR LOWER?
A33C BLO   $A342     IF UPPER PRINT IT
A33E ANDA  $$$DF     MASK BIT 6
A340 EOR   $$$40     CONVERT CHAR
A342 STA   , X+     STRE CHAR&INC SCRPTR
A344 STX   $8B      STORE SCRPTR
A346 CMPX  $$$5FF   END OF SCREEN
A349 BLS   $A35D    RETURN IF NOT
A34B LDX   $$$400   X-REG=START OF SCREEN
A34E LDD   $20,X    MOVE CHAR UP
A351 STD   , X++    STORE CHAR&INC X-REG
A353 CMPX  $$$5E0   LAST LINE?
A356 BLO   $A34E   IF LESS DO IT AGAIN
A358 LDB   $$$60   B-REG=SPACE
A35A JSR   $A92D   GO TO CLS
A35D PULS  A,B,X,PC  RETURN
A92D STX   $8B      SAVE SCRPTR
A92F STB   , X+     STORE CHAR&INC X-REG
A931 CMPX  $$$5FF   END OF SCREEN?
A934 BLS   A92F     DO IT AGAIN
A936 RTS

```

## NEW FOR THE COLOR COMPUTER GRAF PLOT HIGH RESOLUTION DATA GRAPHING

GRAF PLOT turns your COLOR COMPUTER into a sophisticated data plotter, producing professional quality graphs of any type of X-Y data. GRAF PLOT is perfect for personal, business, statistical, scientific and engineering applications. Includes features not found in any other COLOR COMPUTER graphing system:

- 222x174 pixel on-screen data plotting area.
- Complete on-screen labeling for two Y-axes w/200 data points per axis. Leven more points by chaining data files.
- 9 graphing options: 3 symbols w/2 line types or points only.
- Full function data editing: add, change, delete and sort.
- Hardcopy w/standard screenprint programs (not supplied) - includes interface for Tandy SCRPT w/instructions for interfacing other printers and screenprint programs.
- Unlimited overlays - plot 9 or more data sets per graph.
- Graphs output to screen, printer, tape or disk.
- Plots any user-defined function, edit 4 program lines.
- Built-in data smoothing (moving binomial average).
- Built-in integration - calculate areas or evaluate integrals of user-defined functions.
- Lists data and integrals to screen or printer.
- Saves completed graphs for instant reloading.
- Menu-driven w/auto-prompt option for fast throughput.
- Complete error trapping - GRAF PLOT won't let you make a mistake, practically impossible to crash.
- Comprehensive manual w/tutorials and sample data.

GRAF PLOT is available for 16K E.C.B. on cassette (\$35) and 32K-1 disk (\$45). Easy upgrade to disk for difference in price (disk version reads and writes tape data files). Send check or money order to: HAWKES RESEARCH SERVICES, 1442 Sixth St., Berkeley, CA, 94710. Include \$3 S/H on all orders. Manual available separately for \$10+S/H, refundable with purchase of GRAF PLOT. CA residents add state sales tax. Dealer inquiries welcome. Quantity discounts available.

# NOW THERE ARE TWO TOOLKITS FOR THE COLOR COMPUTER

The software development tools that let you put even more **power** into the already powerful Color Computer. They're full of tools, aids, bells and whistles useful to the BASIC or MACHINE LANGUAGE programmer, in friendly, easy-to-use software packages.

## BOTH TOOLKITS CONTAIN . . .

- **Light characters on dark background with Current Line Highlighting;** or normal characters
- **Full Screen Editor** with **Arrow Key controlled cursor; open up space/delete and close up space**
- Enabling selective **Line Renumber/copy/move/merge;** or normal Extended Basic line editor
- **Protect** the current BASIC program from being wiped out with a CLOAD, NEW etc.; or from being LISTed
- **Restore** a protected BASIC program/**Append** any number of BASIC programs together easily
- **Tone** on keypress or normal silent keys (Tone modifiable by use of Sound n,n Command)
- **Global Search** of command or text strings in BASIC programs with **wildcard** character and **next "."**
- **9 Screen Print Delays** with keyboard override (for slow, readable LISTings and DISK DIRECTories)
- **Variable Name List/String-Byte** memory usage/Range of FREE MEM/Top of memory address display
- Fast Machine Code to BASIC DATA **converter** for storing machine code visibly in BASIC
- (C)SAVEM address/**Backup Tool** (Last file name, start, end and execute address)
- **Recovery of Lost BASIC** programs after NEW, BACKUP, DSKINI, etc.
- **Break Key Disable/Enable** (Pause keys still available)
- **Modified TRON** display (.LN replaces (LN))

## THE FULL TOOLKIT ALSO CONTAINS . . .

- Merge BASIC** with Machine Code routines so machine code is "invisible" and (C)SAVE/(C)LOADable
- 9 BASIC RUN delays** with keyboard override; **Single Step(s)** mode with current line number display
- Memory Examine/Modify** with HEX/ASCII/DEC/Double Decimal output and HEX/ASCII input
- Memory **Block Move** for relocating machine code programs, DATA blocks, etc.; or the Kit itself
- Ten User Defined Function Keys** accessible with @/number (BASIC Macros/Block storage)
- Automatic linefeed** for printers that don't/double space LISTings; or normal PRINT
- Delete all spaces** (not in PRINT strings, DATA or REMARK lines)
- ASCII/HEX memory **Dumps** to screen or printer
- Delete all REMarks** (either REM or ' type)
- Parallel **ECHO** of screen output to printer

## THESE FEATURES ARE FOUND ON BOTH VERSIONS . . .

- **Transparent** to the user, install it and forget it until you need it
- BASIC runs up to one-third faster through the Toolkit (5-10% typical)
- **HELP** command lists all Kit commands and current Kit address
- Same program works with tape or disk and in 16 or 32K
- Entire system totally **removable** at any time
- **Compatible** with other utility programs
- Green/Orange text screen capability
- Easily **modifiable** command syntax

The Kits are relocatable programs that load any time without bothering your BASIC program or variables or top of memory address. All tools may be turned on or off at will, including the Kit itself.

The tools are available with simple three or four letter commands entered in the direct mode, with the entire instruction set viewable through the HELP command.

The Colorkit is 5K bytes for \$29.95  
Available on disk with handy BASIC Kit loader for additional \$5



The Microkit is 2.5K bytes for \$27.95  
Manual available separately for \$5

### THE GOOD LIFE

\$16.95

- The Classic Game of Life With:
- 64x64 color symmetrical display
- **3 Selectable birth and old age colors**
- **15 modifiable pre-programmed patterns**
- **Save/Load life screens to tape/disk**
- **Speeds from 8 gen/sec to 1 a second**
- **Joystick or arrow key input**
- **Written in user-modifiable BASIC**
- **With machine code LIFE processor**
- **Help screen command list**
- **Tape/Disk compatible**
- **Selectable color sets**
- **Y&X axis wraparound**



### THE DISK COMMANDER

\$19.95

- Disk File Utility with:
- **One key view/copy/load(m) of files**
- **Two key kill/rename of files**
- **Sort directory on name/extension**
- **Pack directory so new files put at end**
- **Directory keyword search of filename**
- **Print DIR with machine code address**
- **Recover killed files**

### DEER HUNT

\$15.95

- **Arcade shoot-em-up skill game**
- **Aim only for the deer**
- **Avoid hitting people, cars, train**
- **Will not cause tension headache**
- **BASIC/machine code hybrid**
- **Tape/Disk compatible**

**ARIZIN**  
**P. O. Box 8825**  
**Scottsdale, AZ 85252**



## CoCo Adds Dimension Of Fun To Tic Tac Toe

Tic tac toe program? My first thought was, "Why would I want to buy such a simple program?" Then I saw that this program was 32K ECB. Wow. . . Why so much memory for such an easy game? That was one of the first programs I put into my computer! Curiosity made me to it!

3-D Tic Tac Toe takes almost three minutes to load. Running the program brought up some nice introductory graphics in hi-res along with some oscillating sound effects. (The program runs with the speed-up poke, so if your computer does not work in hi-speed you should eliminate line one. There does not appear to be any annoying slowdown in play if you do have to remove the speed-up.) The next prompt is the option to play against the CoCo or another person, after which the 3-D board is generated and displayed.

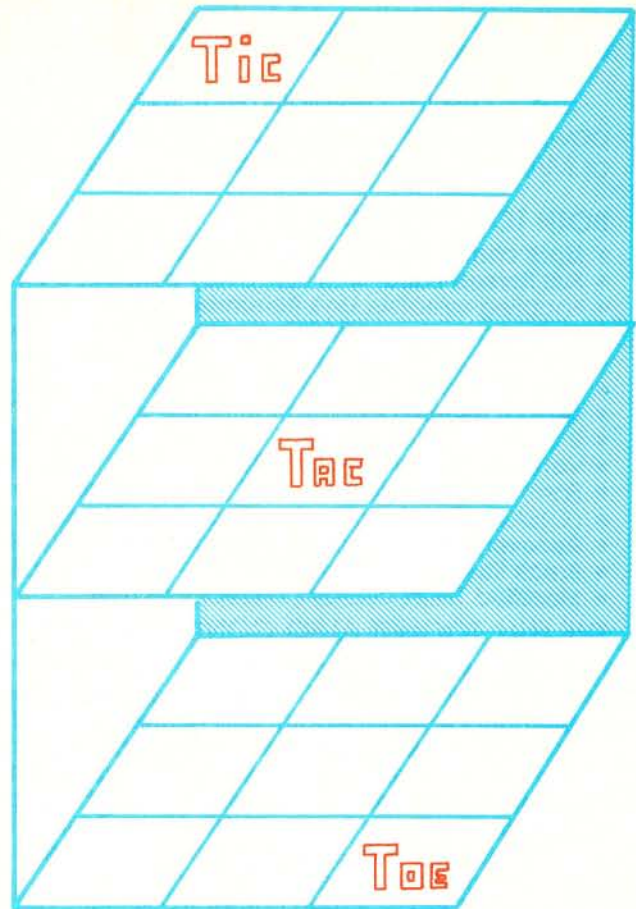

### New! For Your Color Computer FROG-TREK

(the arcade game)



*You may be able to guide your frog through 6 lanes of rush hour traffic, but that isn't enough! You must also cross the river by jumping on logs and turtles to get Froggie safely to his home on the other side. But watch out for the snake! And don't jump on the industrial waste.*

*A great M/L game at a great price \$14.95. Uses hi-resolution graphics and requires 16K. Arrows on keyboard move frog- no joy-sticks required.*

*Send check or money order for \$16.50 (includes shipping) to:*

**OELRICH PUBLICATIONS**  
**4040 N. Nashville**  
**Chicago, IL 60634**  
**CALL TOLL FREE TO ORDER**  
**800-621-0105**  
**MASTERCARD AND VISA ACCEPTED**

I do drawings part-time in my work and have reproduced the board elsewhere in this review, so that you may see how the 3-D board is achieved. It's a conventional representation of a 3-D cube on a two-dimensional paper (or TV screen in this case) and gives the illusion of 3-D. I know some people have difficulty visualizing 3-D concepts. If you cannot visualize the playing board and the potential tic tac toes in the drawing then maybe this game would *not* be for you! *Then again*, it might be just what you need to finally understand 3-D pictures.

It is easy to become disoriented while looking at the board, though it is well-drawn. Several times I would look up and see the illusion of the cube being rotated a quarter-turn to the left and upward. However, this reorientation does not change the position of the markers nor the playing strategy since things are still in their relative locations. I just want to point out this in case you have not worked with two-dimensional representations of 3-D drawings before.

The graphics are well done in hi-res. The computer moves take from two to four seconds. Human moves (which generally take longer) are made through the four arrow keys and the *ENTER* tab. According to the author, there are more than 150 possible ways to get *Tic Tac Toe*, so games are generally fast, depending upon the human factor.

Documentation is quite complete and gives anyone the necessary information to play all options. However, I do feel the documentation is a little misleading. The programmer points out: "We averaged about a 50 percent win in the games we played against CoCo. But then we had a fair idea of what CoCo was thinking since we told him how to play! One thing you can be sure of is that CoCo will not miss a

# YORK 10™

# BASF-DPS

WORLD STANDARD TAPE

**MONEY BACK  
GUARANTEE**

## COMPUTER GRADE BLANK CASSETTES

PREMIUM 5-SCREW SHELL WITH LEADER FITS ALL STANDARD RECORDERS  
PREFERRED BY SOFTWARE PRODUCERS, SCHOOLS AND BUSINESSES NATIONWIDE



DATA TRAC / C-05, C-10, C-20

### CASSETTE STORAGE CADDY

**NEW!**  
ORGANIZE  
YOUR TAPES!  
\$2<sup>95</sup> EACH



STACKABLE

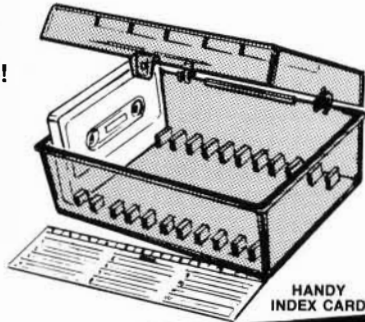

HANDY  
INDEX CARD

### HERE'S WHAT USERS SAY ABOUT YORK 10 CASSETTES:

"It's nice to have a tape you can rely on 100% of the time to perform with such quality. And the fast, courteous service was a pleasant surprise."  
Tom Parkinson-Madison, OH

"We monitored the output to the computer with a specially built meter and found absolutely no dropouts throughout the tape..."  
Stace Papadopoulos-Beaverton, OR

"YOU'VE TRIED THE REST, NOW BUY THE BEST"

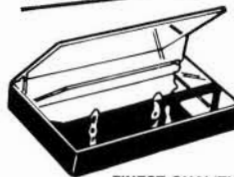

FINEST QUALITY  
PHILIPS (NORELCO)  
TYPE HARD BOXES

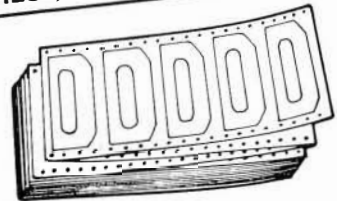

TRACTOR FEED  
DIE-CUT BLANK  
CASSETTE LABELS

**INTRODUCTORY OFFER!**  
ORDER 2 DOZ. CASSETTES AND 1 CADDY  
GET 1 CADDY FREE!  
ORDER 4 DOZ. CASSETTES AND  
2 CADDIES — GET 2 FREE

OFFER EXPIRES AUGUST 1, 1983



Call: 213/710-1430  
FOR IMMEDIATE SHIPMENT  
on Credit Card Orders.



ORDER NOW **YORK 10™ Computerware**  
Mail To ...

24573 Kittridge St., #R Canoga Park, CA 91307

ITEM	1 DOZEN	2 DOZEN	TOTAL
C-05	<input type="checkbox"/> 7.50	<input type="checkbox"/> 13.50	
C-10	<input type="checkbox"/> 8.00	<input type="checkbox"/> 14.40	
C-20	<input type="checkbox"/> 10.00	<input type="checkbox"/> 18.00	
Hard Box	<input type="checkbox"/> 2.50	<input type="checkbox"/> 4.00	
Storage Caddy @ \$2.95 ea.:	Quantity: _____		
	FREE: Quantity: _____		
Blank labels	<input type="checkbox"/> 4.00/100	<input type="checkbox"/> 30.00/1000	
<b>SUB TOTAL</b>			
Calif. residents add 6% sales tax			
Shipping/handling 1 doz. \$2; 2 doz. \$3.50; 3 doz. \$4.50; each additional doz. \$50.			
For Parcel Post instead of UPS \$1 additional			
Outside Continental USA, \$2 additional			
<b>TOTAL</b>			

Each cassette includes two YORK 10 labels only. Boxes are sold separately. Shipments are by U.P.S. unless Parcel Post requested. Boxes, caddies, and blank labels are free of shipping charges when ordered with cassettes. When ordered without cassettes, shipping charges: Boxes—\$1.00/doz., Caddies \$1.00 each. MINIMUM SHIPPING/HANDLING ON ANY ORDER—\$2.00.

Check or M.O. enclosed  Charge to Credit Card:  VISA  MASTERCARD

Card No. \_\_\_\_\_ Exp. \_\_\_\_\_

Name \_\_\_\_\_

Address \_\_\_\_\_

City \_\_\_\_\_ State/Zip \_\_\_\_\_

Signature \_\_\_\_\_

Computer make & model \_\_\_\_\_ Disk?(y/n) \_\_\_\_\_

CHECK HERE FOR QUANTITY DISCOUNTS PRICE LIST



block or a chance to win ... an exciting game and challenging ... a real teaser ... just when you think you have won, CoCo beats you to it."

After reading the documentation I was all prepared to play a 'difficult' game of *3-D Tic Tac Toe*. To my disappointment, I won the first game in four moves, then the second game, the third ... until I had won 15 games to the computer's one! Not all games were simple four-move wins, as the loser of the previous game starts the next game. I don't think I would have been so disappointed had I not read the documentation first. After all, I remember the regular game as being *easy*.

Another observation I made—or think I made—is that the computer did not always catch the blocks! So, I tried various combinations and could continuously make CoCo miss a block. Then, in all fairness, I thought maybe I had overlooked something or had received an earlier version of the game and decided to call the author. Both of my disturbing observations were put to rest.

First of all, I want to make it clear that the computer *does in fact* catch all blocks. I was too quick to notice the most obvious block CoCo had apparently missed when in reality I had at least doublechallenged CoCo and CoCo had decided to take a different block than the one I had my eyes on. I had looked at the program and thought, "Gee, with all these *IF/THEN* statements in here, there could easily be a bug or logic statement missing somewhere. (There are over 300

*IF/THEN* statements to check computer moves/wins and human moves/wins, etc. I didn't count them ... I took the author's word for it! He tried data arrays and other methods, but they took much longer for CoCo to react than the way the program is currently set up.)

Concerning the misleading documentation suggesting a "challenging" game, I would like to point out the program was apparently written with younger people in mind, probably in the range of 5-12. This is the general age group I thought suitable for this program prior to talking with the author. In fact, he said most of his software is aimed at younger people. I think the documentation should reflect this a little more.

For the price, *3-D Tic Tac Toe* has a lot going for it. If you don't have a game like this, it would be a great way to introduce or to build upon 3-D concepts for members of the family. It also makes an adult think a little more. It has good graphics. My older kids will soon be six and nine and they seemed to enjoy the game! The six-year-old could even beat the computer and understand that one mark on each level directly above meant a tic-tac-toe, although the three-level diagonals were harder to understand. Welcomed excitement rang throughout when he was able to beat CoCo!

There are a couple of things lacking in this program that would increase its usability and enjoyment. After a game is won, the screen is immediately erased and set up for a new game. There should be either a timer or a prompt included to allow the player(s) time to see where the tic tac toe was! This change in the program would be most beneficial in helping understand 3-D. That feature and the two suggestions following could be written in by most consumers I think. However, you may have to delete some REM statements or remove excess spaces throughout the program to get all the changes put in, as it's already almost 32K in length. The other two suggestions have to do with the two-player option.

All movements are made using the four arrow keys. When two players engage in this game, it becomes confusing! One person must use the *ENTER* to place his marker, while the other uses the *CLEAR*. Since *ENTER* is the most commonly used key on the keyboard, it is very natural and easy for one of the persons to accidentally hit *ENTER* when he wanted to hit *CLEAR*. Needless to say, that game is ruined! It's also annoying for two people to keep shuffling around the keyboard. If the game has to be played from the keyboard it would have been nice to designate pushing "0" for circles and "X" or X's. I would suggest incorporating the joysticks and fire button for two-player response (maybe even for one player).

One last comment about the two-player option is that one person can monopolize the play. There is no check or indication for whom is to play. One human assumes the role of CoCo on the screen's scoreboard, and a person can continue to move and mark the board until he wins without the other person ever having a chance to play! The only check the computer does do is make sure you cannot change a marker already in place. It signals you that you cannot make that move.

In general, the program is easy to play, is good for younger children, and has potential. An interesting version of an old game.

(Q Soft, 1006 Robinhood Dr., Painesville, OH 44077, \$14.95 tape, \$19.95 disk)

—Kenneth D. Peters

**"CARRY"**

$$\begin{array}{r}
 \begin{array}{|c|c|} \hline 1 & 1 \\ \hline 3 & 9 \\ \hline \end{array} & 7 \\
 + & \begin{array}{|c|c|c|} \hline 5 & 2 & 8 \\ \hline \end{array} \\
 \hline
 9 & 2 & 5
 \end{array}$$

**REGROUPING IN ADDITION**  
Requires 16K Extended Basic      Cassette    \$19.95

\*TRS-80 Color Computer      Ohio Residents  
\*Trademark of Tandy      Add 5½% Sales Tax

**APPEALING GRAPHICS, FUN REWARDS AND SOUND**  
Used Successfully In Classrooms and In Homes

**ALSO AVAILABLE-CASSETTES**

Clock	\$24.95	Mathfact	\$16.95
Money	\$19.95	ABC's	\$ 9.95
Subtract/Borrow	\$19.95	Spelling	\$16.95
Question	\$19.95	Hangword	\$14.95

**WRITE FOR FREE DESCRIPTIVE BROCHURE**  
**DEALER INQUIRIES WELCOME**

**B5 SOFTWARE**



1024 Bainbridge Pl.      Columbus, OH 43228  
(614) 276-2752





# Legal Discussions On The Color Computer

By Tom Nelson

*(The information given in this article is not legal advice. If you have legal questions you should see competent legal counsel.)*

This month begins a series of columns which will try to answer some of the most-asked questions from software authors, marketers and consumers. It is a wide open forum, and I hope you will feel free to suggest further topics which you would like to see addressed. By the way, for those of you able to attend, I will be giving a short seminar at the upcoming RainbowFest in Chicago on the topic of "How to Market Your Software—And Keep Your Shirt." I hope to see you there.

This first column will not be a discursion into some arcane area of the law. Instead, because some of you may really be in need of some basic legal information about your software immediately, I thought I'd review a brand new book about legal protection for your software entitled "Legal Care for Your Software: A Step-by-Step Guide for Computer Software Writers," first published in 1982. It was written by Daniel Remer, an attorney, is sold by Addison-Wesley Publishing Company, Inc., and costs \$19.95 in paperback. Instead of giving you a summary of the contents of Mr. Remer's book, I intend to whet your appetite by setting out an outline of the general contents of the book.

I highly recommend this book to anyone considering marketing software, from author to manufacturer. Mr. Remer, in the span of about 150 pages, presents most of the concepts necessary for you to understand what you must do to protect your software. This book is not legalese. It is practical advice. Instead of telling you what such and such a court said about some intricate legal doctrine, Mr. Remer tells you how to avoid future legal troubles by taking precautions in advance. This doesn't mean, however, that the book is not comprehensive. It is, where it has to be, and Mr. Remer freely cautions the reader when he or she must consult an attorney, such as when a trademark question arises.

After an overview of the need for legal protection and what is available, the author discusses how to practically obtain and maintain trade secret and copyright protection, currently the two main methods of protecting your software. Anything related to a business can be a trade secret, even if others have independently developed it. Thus, marketing strategies as well as source code can have trade secret protection. What you want to do is be able to protect these trade secrets from others, the purpose of trade secret law. The notion of copyrights should be familiar to us all, although the finer points are not common knowledge. Mr. Remer makes both these concepts more concrete. He also points out the present problems of trying to use patents to protect your software and the need to obtain trademark protection for your program name and company logo.

The guts of the work, and that which many of you will find most helpful, is the discussion of contracts. Contracts are

the vehicle for all our financial transactions, especially those dealing with our "intellectual property." Mr. Remer has sought to provide the software author and manufacturer with all the necessary contract concepts, including hints on how to negotiate good contracts. What's more, he has provided sample forms for all of these contracts at the end of the book which you can just tear out and use, modified as needed. He stresses the need for written agreements to avoid future disagreements over terms, and to guide our relationships with people we often never meet face to face. I must applaud Mr. Remer's ability to explain these sometimes complicated concepts with ease so that anyone should be able to understand them.

The book introduces you to the concepts of most of the kinds of contracts essential for the sale or development of software. He first discusses work-for-hire agreements which are used to contract with programmers, in-house or not, to write software and allow the software house to retain the copyright. He then discusses agreements to be used to assign your copyright to firms, and license agreements when you don't want to sell the copyright, but only wish to give a company the right to market the software and pay your royalties. He discusses the pros and cons of these two types of agreements, and things to watch out for. For the manufacturer, he also provides information on how to create test site agreements for outside, independent, pre-marketing testing of the software, and information on how to correctly limit liability for defective software. His discussions of these two types of contractual arrangements are excellent and alone are easily worth the price of the book. Finally, Mr. Remer discusses remedies available when the contract has gone sour, and just as important, practical ways to approach legal problems. I particularly appreciated his comment that most legal disputes can be resolved with a bottle of wine and an apology.

It is obvious that Mr. Remer has had extensive experience in the software field. His practical tips alone are well worth the price of the book. The tear out forms, however, are what many of the readers will find most valuable. As I mentioned, he includes examples of all the contracts he discussed, including a trade secret agreement and non-disclosure agreement to keep those valuable company secrets, from source code to marketing strategy, secret; an assignment of copyright agreement for those wishing to sell their program to a manufacturer; a work-for-hire agreement for manufacturers to use when hiring staff or outside programmers; a test site agreement; a license agreement; and a sample disclaimer of warranty. Each of these documents is fully explained in the chapter dealing with the topic, and many alternative clauses are offered to suit varying needs.

The book does, in my opinion, have a few deficiencies. The first relates to different philosophies between me and Mr. Remer about the advisability of people doing their own

# ENTER INTO THE NEWEST DIMENSION FOR THE COLOR COMPUTER AND TDP-100

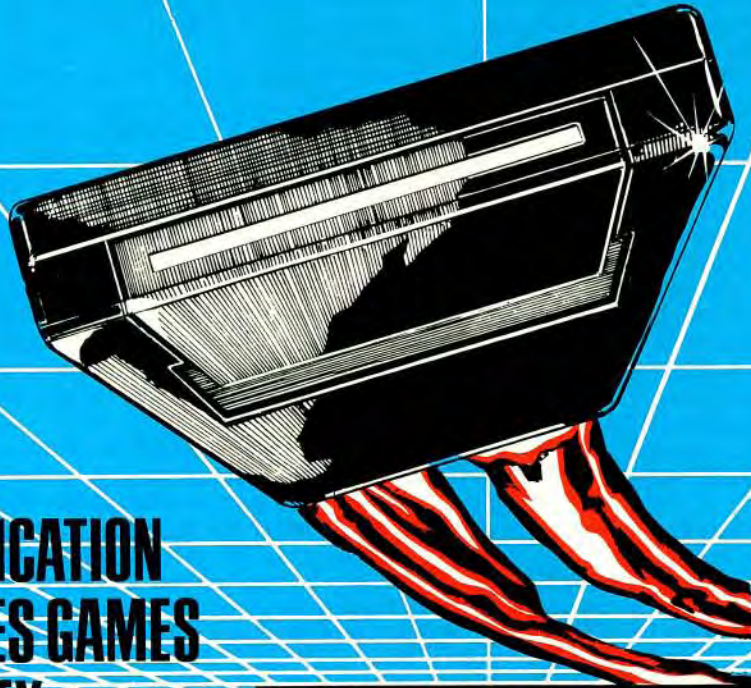

**APPLICATION**  
**HI-RES GAMES**  
**UTILITY**  
**EXPERIMENT**  
**2-K**  
**4-K**  
**8-K**  
**16-K**  
**KITS**



## ROM PAC

### PUBLISHERS

Anteco will put your programs in professional, convenient ROM PAC form.

### DEALERS

Specify Anteco ROM PACs when you order from your favorite publisher.

### ENGINEERS

If you are writing or designing ROM PORT software, look to Anteco for a ROM PAC kit to "professionalize" your work.

Call or write  
**ANTECO** 4220 Clay Ave.  
Fort Worth, Texas 76117  
1-800-433-7631

**ANTECO**  
division of  
Antenna Electronics Co.



legal work. Mr. Remer feels that if you read the book and understand the concepts you should be able to use his forms with great success without the aid of an attorney. In general, I disagree.

Although Mr. Remer has done a great job of outlining the basic concepts of contract and intellectual property law, this book does not make anyone an expert. These laws contain many traps for the unwary, especially trademark law. Further, contract law and trade secret law, though similar in most states, is still governed, to a large extent, by the laws of each state. Each state may have some special requirements which may have to be included in a contract, or followed in trade secret protection procedures, and the forms provided in the book cannot hope to deal with such local idiosyncracies.

The forms provided in the book are not necessarily complete. In reviewing the forms, I noticed the lack of several clauses which I consider standard for any contract. Moreover, these forms only cover the usual things put in a contract. Which one of us is willing to admit that he or she is usual? Rarely is a contract so simple that there is not some special set of clauses which must be included, especially relating to payment terms. Care must be taken to make sure the clauses are written in an airtight manner, and are fully consistent with other parts of the agreement. You will never be sure that you have done it right yourself because, really, you don't have the training.

Besides, refusing to hire an attorney is a bad form of gambling. Your software may be the greatest thing since Pac-Man, and worth millions, or it may be a giant flop, or somewhere in between. Unfortunately, it is impossible to know the end worth of your program when you want to

present it for marketing. When such money is at stake, it is unwise to venture forth into untested waters of contract law. Why gamble with such an important agreement? Remember, too, that if you commit malpractice with your contract you can't sue yourself, but attorneys are insured to cover such unfortunate, and quite rare, occurrences.

It does not cost that much to consult an attorney on a contract, especially if you have read this book and are familiar with the general clauses, or even have drawn up a prototype contract. The more you have done, the less your attorney has to do, and so the lower the bill. Your attorney will like it too. Contrary to popular belief, most lawyers find it a real joy to have a client who has an understanding of the basic concepts of the law and of his or her problems. Of course, you want to find an attorney who knows a byte from a bit and who has done this sort of thing before. Intellectual property law is a specialty, and if you are paying for expertise you should find someone worth the money.

This advice applies to software houses, too, but I doubt many need the advice, since there are so many other things one needs an attorney for when starting a business. Such things as incorporation or business formation, tax considerations, basic contracts and the like confront the software house from day one.

A second problem with this book is that, although it is rich in legal practical advice, it really lacks information about the software market. If Mr. Remer had spent some time to research the market to inform the reader about the common practices, prices, royalties and contracts used by software houses, big and small, it would be a great help to the software writer in need of a market. This absence of information is somewhat understandable since, as of yet, the

# SOUTHERN SOFTWARE SYSTEMS

SERIOUS SOFTWARE FOR THE COLOR COMPUTER  
*Presenting... THE GRAPH ZAPPER and THE BAR ZAPPER*  
Line Graphs and Bar Graphs for the Color Computer

- **THE GRAPH ZAPPER** plots line graphs of data and equations - multiple lines with different symbols - mix equations and data on the same graph - plots lines or points - *"The Graph Zapper is one of the most completely documented pieces of software we have seen . . . The Graph Zapper is an outstanding utility and can be a major tool in statistical, business and other uses where graphic representation of numbers is desirable."* The Rainbow, Dec. 1982.
- **THE BAR ZAPPER** creates bar graphs with multiple bars - plenty of options - shaded or light bars - positive and negative bars - a great companion to **THE GRAPH ZAPPER** — same high quality documentation.
- Endless applications - electric consumption, stock prices, math class equations, children's height and weight, data analysis, trend indication, experimental results, statistical analysis.

## Both ZAPPERS Have All These Features:

- High resolution graphs with on screen numbers & labels, with or without grids.
- Sophisticated data editor makes changing data simple.
- Disk version has added features including storing completed graphs on disk and menu driven file loading.
- Detailed user's guides for all features.
- 14 day money back guarantee.
- Requires Ext. Color Basic and delivered on cassette.
- User friendly, easy to understand.
- Thorough error prevention.
- Save data for later graphing or editing.
- Low cost upgrade from tape to disk.
- Hard copies possible with common screen print programs - not supplied.
- Low resolution graphs can't compare.

**\$15.95**

for 16K tape versions

**\$19.95**

for 32K disk versions

add \$1.00 for shipping . . . send check or money order

**\$29.95** for both tape versions + **\$2.00** shipping

**\$37.95** for both disk versions + **\$2.00** shipping

Florida residents add 5% sales tax

**SOUTHERN SOFTWARE SYSTEMS**

485 South Tropical Trail, Suite 109 • Merritt Island, Florida 32952 • (305) 452-2217



software market is still a hit-and-miss proposition, with neither software house nor author sure what is appropriate. There does not yet appear to be any standard contract in the software market like there are in the music and entertainment industries. I plan in a later article to discuss the market forces from the perspective of Nelson Software Systems to at least give some idea of how one software house copes with the market.

One final failing of the book involves a suggestion for an additional chapter. Although Mr. Remer has dealt well with the types of contracts he considers essential to the software author, he has missed two universally used contracts, the software submission agreement and the option agreement. A software submission agreement is used by many companies, including Nelson Software Systems, to protect itself and the author submitting software from future misunderstandings. It sets out the conditions under which the software house will agree to look at the software. This is necessary so that problems don't arise in the future such as a claim that a software house stole a program. It also helps clarify the terms under which the software will be reviewed so that the author can be sure that the software house is reputable. Nothing scares a software house more than receiving a naked copy of someone's source code for evaluation before a submission agreement has been signed. Protect your software by all means, but don't just send it to prospective marketers without first asking for a submission agreement.

An option agreement is a special form of contract in which the software house buys the irrevocable right to decide whether or not to market the submitted software for a limited amount of time, for example 60 days. Such an agreement allows the software house to feel free to devote complete attention to the submission with the knowledge

that it has the sole right to market the program if it exercises its option within the given time. The option is irrevocable and, if the software house exercises it, the contract is final, so care must be exercised by the author. On the other hand, option agreements are also good for the software author. The author knows that the software house will take a hard look at the software, and that he or she will have an answer from the software house within the same amount of time, so that the submitted software does not languish in some file months with no response.

I feel that an understanding of these two types of agreements is essential to the software author and the software house seeking programs from outside sources. Therefore, both of these agreements will be discussed more in a later column. Perhaps Mr. Remer will also include a discussion of these in the next edition of his already good book.

I'm sure that you will find this book a gold mine of information which will help you become a success, and help you protect yourself at the same time. You certainly will be better educated and, unlike other books, you will be back many times for more information.

Next month, I will discuss some basic concepts about marketing your programs, including how to time your submission, and how to decide what kind of program to develop. Until then, good luck with your endeavors.

Tom Nelson is a Special Assistant Attorney General for the State of Minnesota representing various state agencies, and a consultant to Nelson Software Systems. Although Tom was trained in Chinese, he turned to law, and then to the computer. In his association with Nelson Software Systems he has written almost all of the manuals for the programs in the Super "Color" Library. He does all his writing on a Color Computer, using—what else?—the Super "Color" Writer II version 3.0.



---

## the RAINBOW's

# SIMULATION CONTEST

*Write a simulation program in the Rainbow's Simulation Contest. You will have the chance to win valuable prizes and to share your simulation with thousands of Color Computer, TDP-100 and Dragon-32 owners worldwide.*

*Your simulation can be about any subject—and can be either graphic or non-graphic. See examples of simulation programs printed in the Rainbow.*

**A few of the prizes already offered . . .**

**A New Epson FX-80 Printer  
4K Buffer  
Connecting Cables**

**JARB Software**

**Value \$870**

*Hardware Worth \$150  
Software Worth \$75  
Software Worth \$75  
Any Program*

*Spectrum Projects  
Tom Mix Software  
Computer Island  
Custom Software Engineering*

**RULES:** All programs must be original works, no "conversions." Entries must be postmarked by July 30 and become the property of Falsoft, Inc. publisher of *the Rainbow*. Decision of the judges is final. Duplicate prizes will be awarded in the case of ties. Winning programs to be featured in a special *Rainbow* Simulation issue. Mark entries "Simulation Contest Editor" and send to *the Rainbow*, P.O. Box 209, Prospect, KY 40059.



# IOWA LEMONADE

~~10¢~~ 5¢

By Paul French



Shortly after I got my Color Computer, I decided to convert a few programs to run on it. *Iowa Lemonade* is the most ambitious of my conversions. The idea and logic have been around for quite a while and one of the other computer manufacturers sends (or used to send) a version out on a demo disk with their disk drives. It was kind of cute, so I decided to develop one for the CoCo. Since a 16K cassette system was top of the line from Radio Shack at the time I started, the program is designed to fit in 16K Extended Color BASIC.

The graphics are all low-resolution. They are produced with the `STRING$` statement or by concatenating `CHR$` together to make strings that are *PRINTed* at the proper screen locations. The only exception is the lightning (lines 351-362) which is *POKEd* into screen locations read from `DATA` statements (in lines 365-366).

The *POKEs* in lines 367 and 372 take care of inverse video blanks and punctuation marks. I discovered (and have since read elsewhere) that there is a distinct visual difference between the black character that character code 32 produces and the black characters that character codes 128, 144, 160, 176, 192, 208, 224, and 240 produce. I also found that the only way to produce a character in the lower right corner of the display (*PRINT* location 511) without having the screen scroll is to *POKE* the appropriate value into memory location 1535.

In a 16K Color Computer, you must *PCLEAR* before *CLOADing* or typing in the program, or you will run out of memory. I'm sorry for some of the lapses in programming style—some of the `NEXTs` with variable names, some without—some lines with lots of spaces to make them easier to read, a few without. I did try to leave enough comments so you get an idea of what's going on, and the `PLAY` strings all have long variable names so you know what they are. If you want to save a bit of memory, there are over 700 spaces that can be taken out, lots of *REM*-arks, and the variable names beyond two characters can be shortened.

I produced the whole thing on my black-and-white TV. Having since seen it on a color set, I think it turned out pretty well.

The game itself? The computer does the bookkeeping while you and up to 29 friends (or classmates) run your own lemonade stand. It also takes care of the weather and a few other items. Each day, each player has to decide how many glasses of lemonade to make, how many signs to make to advertise, and what the selling price will be for that day. The sole goal is to be efficient at making money. It helps to keep records so you can see what has worked best for you. You can resume a game later, but you have to know what day number it was and how much money players had when they stopped (even though the computer may not allow it all). The game ends when someone earns an agreed upon amount or on an agreed upon day.

*Editor's Note: Simulation contest entrants should note that a computer simulation can be created for most anything, from a nuclear power plant to...well, a lemonade stand.)*

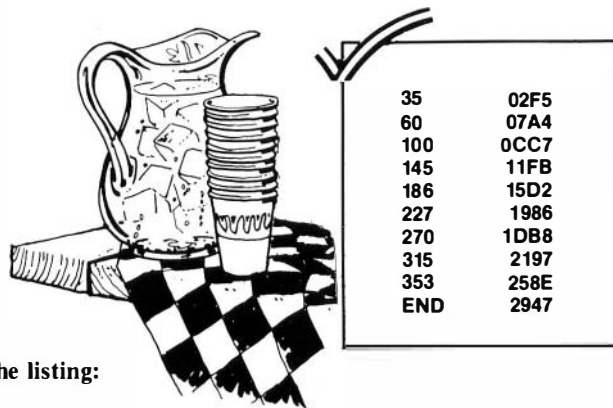

The listing:

```

0 ' iowa lemonade
1 CLEAR 450
2 IOWASONG$="T3;P1;O3;L16.;G;A;B
;O4;L2;C;O3;L8;A;L2;G;P8;O4;L2;G
;L8;E;L2;G;P8;L8.;E;L8;G;L8.;E;L
8;G;L2;D;P8;L8.;E;L8;G;L8.;E;L8;
G;L2;D;P1"
3 ' INTRO
4 CLS0
5 FOR I=1 TO 3
6 FOR J=1 TO 13
7 READ CH
8 IA$(I)=IA$(I)+CHR$(CH)
9 NEXT J,I
10 FOR I=1 TO 3
11 FOR J=1 TO 28
12 READ CH
13 LE$(I)=LE$(I)+CHR$(CH)
14 NEXT J,I
15 RESTORE
16 FOR LO=480 TO -96 STEP -32
17 CLS0
18 SOUND 204,1
19 IF LO=-32 THEN 24
20 IF LO=-64 THEN 26
21 IF LO=-96 THEN 29

```

```

22 PRINT@LO+9, IA$(1);
23 IF LO=480 THEN GOSUB 45: NEXT
24 PRINT@LO+41, IA$(2);
25 IF LO=448 THEN GOSUB 45: NEXT
26 PRINT@LO+73, IA$(3);
27 IF LO=416 THEN GOSUB 45: NEXT
28 IF LO=384 THEN GOSUB 45: NEXT
29 PRINT@LO+130, LE$(1);
30 IF LO=352 THEN GOSUB 45: NEXT
31 PRINT@LO+162, LE$(2);
32 IF LO=320 THEN GOSUB 45: NEXT
33 PRINT@LO+194, LE$(3);
34 IF LO=128 THEN PLAY IOWASONG$
35 NEXT
36 FOR DE=1 TO 900: NEXT: GOTO 4
6
37 ' CHR$ CODES FOR IOWA
38 DATA 157,152,149,156,157,128,
154,149,128,154,149,156,157
39 DATA 149,128,149,128,149,128,
154,149,128,154,149,147,151
40 DATA 151,146,149,147,151,128,
155,151,147,154,149,128,149
41 ' CHR$ CODES FOR LEMONADE
42 DATA 154,128,128,149,156,156,
128,158,157,156,154,149,156,157,
128,159,128,154,149,156,157,128,
158,157,146,149,156,156
43 DATA 154,128,128,149,146,128,
128,154,149,128,154,149,128,149,
128,154,154,154,149,147,151,128,
154,128,154,149,146,128
44 DATA 155,147,146,149,147,147,
128,154,149,128,154,149,147,151,
128,154,149,154,149,128,149,128,
155,151,152,149,147,147
45 FOR DE=1 TO 250: CLS0: RETURN
46 DIM A(30),L(30),H(30),B(30),
S(30),P(30),G(30)
47 P9=10
48 S3=.15
49 S2=30
50 A2=2.00
51 C9=.5
52 C2=1
53 ' DEF MUSIC
54 MONEYSONG$="T3;O3;L8;G;F;G;F;
L4;E;C"
55 SUNSONG$="T4;O3;L4;B-;G;D;E-;
G;B-;L2.;O4;D-;C;P1;P2"
56 HOTSONG$="T3;O4;L4;E;C;L1;E;L
8;E;P8;L8.;D;L16;C;L8.;D;L16;E;L
4;C;O3;L2;A;L2.;E;P1"
57 CLOUDSONG$="T3;O4;L8;D;C+;L4;
D;C;C;O3;L8;B;L2.;B;P1;P2"
58 RAINSONG$="T2;O3;L4;A;L8.;A;L
16;A;L8.B-;L16;A;L8.;G;L16;F;L4.
;A"
59 BANKRUPT$="T2;O3;L8;A;L8.;A;L

```



```

8;E;L8.;G;L2;A;P8;L8.;G;L8;A;L16
;EC;L4;O2;A;L8;G;O3;C"
60 ' START OF GAME
61 ' TITLE PAGE
62 CLS
63 PRINT "HI! WELCOME TO LEMONS
VILLE, IA."
64 PRINT "IN THIS SMALL TOWN, YO
U ARE IN"
65 PRINT "CHARGE OF RUNNING YOUR
OWN"
66 PRINT "LEMONADE STAND. YOU C
AN COMPETE";
67 PRINT "WITH UP TO 30 OTHER PE
OPLE, BUT"
68 PRINT "HOW MUCH PROFIT YOU MA
KE IS UP"
69 PRINT "TO YOU (THE OTHER STAN
DS' SALES"
70 PRINT "WILL NOT AFFECT YOUR B
USINESS). "
71 PRINT: PRINT "IF YOU MAKE THE
MOST MONEY,"
72 PRINT "YOU'RE THE WINNER!": P
RINT
73 PRINT@416, "IS THIS A NEW GAM
E (Y OR N)";: INPUT A$
74 A$=LEFT$(A$,1): IF A$<>"Y" AN
D A$<>"N" THEN 62
75 PRINT@448, "HOW MANY PEOPLE A

```

```

RE PLAYING";: INPUT N$
76 N=VAL(N$): IF N<1 OR N>30 THE
N 62
77 FOR I=1 TO N: B(I)=0: A(I)=A2
: NEXT
78 IF A$="N" THEN 115
79 ' NEW BUSINESS
80 CLS
81 PRINT "TO MANAGE YOUR LEMONAD
E STAND,"
82 PRINT "YOU WILL NEED TO MAKE
THESE"
83 PRINT "DECISIONS EACH DAY:"
84 PRINT:PRINT "(1) HOW MANY GLA
SSES OF LEMONADE";
85 PRINT " TO MAKE FOR THE DA
Y,"
86 PRINT "(2) HOW MANY ADVERTISI
NG SIGNS"
87 PRINT " TO MAKE (SIGNS COS
T 15 CENTS";
88 PRINT " EACH),"
89 PRINT "(3) WHAT PRICE TO CHAR
GE FOR"
90 PRINT " EACH GLASS."
91 PRINT:PRINT "YOU WILL BEGIN W
ITH $2.00 CASH"
92 PRINT "(ASSETS). "
93 FS=0: GOSUB 367
94 CLS
95 PRINT "BECAUSE YOUR MOTHER GA
VE YOU"
96 PRINT "SOME SUGAR, YOUR COST
TO MAKE"
97 PRINT "LEMONADE IS TWO CENTS
A GLASS"
98 PRINT "(THIS MAY CHANGE IN TH
E FUTURE). "
99 PRINT "YOUR EXPENSES ARE THE
COST OF"
100 PRINT "THE LEMONADE PLUS THE
COST OF"
101 PRINT "THE SIGNS."
102 PRINT: PRINT "YOUR PROFITS A
RE THE DIFFERENCE"
103 PRINT "BETWEEN THE INCOME FR
OM SALES"
104 PRINT "AND YOUR EXPENSES."
105 FS=0: GOSUB 367
106 CLS: PRINT "THE NUMBER OF GL
ASSES YOU SELL"
107 PRINT "EACH DAY DEPENDS ON T
HE PRICE"
108 PRINT "YOU CHARGE AND ON THE
NUMBER"
109 PRINT "OF ADVERTISING SIGNS
YOU USE."
110 PRINT: PRINT "KEEP TRACK OF
YOUR ASSETS,"
111 PRINT "BECAUSE YOU CAN'T SPE

```

**INSIM** Instruction Simulator  
 Simulates the complete 6809 instruction set.  
 Use it to quickly debug assembly programs.  
 Use it to find out how other programs work.  
 Use it to find out how the basic roms work.  
 Output to screen or printer.  
 Includes commands to examine and change memory.  
 Even has a mini-disassembler  
 16K STANDARD/EXTENDED.....\$39.95

**COMPRESS** Reduce basic program size.  
 Removes spaces and comments.  
 4K OR 16K.....\$7.95

**INTRST1** The interest calculator  
 Calculates home mortgage payments or any  
 loan payments.  
 Calculates interest, total interest, total  
 paid, amount due.  
 Calculates how much to invest now to retire  
 in style in 30 years.  
 This program will calculate future values,  
 present values and much more!  
 16K STANDARD.....\$12.95

**DEPREC** Calculate depreciation using:  
 Strait line, production unit, working hours,  
 declining balance, sum-of-the-years digits.  
 16K EXPENDED.....\$10.95

## B.C. ENGINEERING

P.O. BOX 768  
 MANCHESTER, MO. 63011

SEND CHECK OR MONEY ORDER.  
 MO. RESIDENTS ADD 5.625% SALES TAX.



# PETROCCI FREELANCE ASSOCIATES



Enter the Wild West Days as you try to carry gold across the desert in a stagecoach. Hot in pursuit are the James Gang and of course, Indians!! To make matters worse you are responsible for the safe journey of Annabelle, the judge's daughter. Hi-Res graphic screen plots your progress. Lots of fun surprises await you in this game -shootouts, kidnappings and more. Don't miss the fun!

16 K Extended . . . . . \$19.95

## Stress Evaluator

Assess your present level of stress and how it affects your potential for illness. Evaluate the amount of life change you can effectively handle in the future. The Stress Evaluator is a valuable tool for recognizing, measuring and managing stress. The program also provides a Coping Ability Test which shows your ability to handle stress in general. Provides goal setting exercises and meditation graphic screens to help achieve stress-alleviating goals. All results output to printer.

16K Extended . . . . . \$24.95

## Weather Watch

If you **really** care about the weather, this program is for you. Three programs provide you with National Weather Service approved statistics in a monthly report format. Input of daily high and low temp. and rainfall outputs a report of monthly average temps. and range; high and low averages; high and low temp. for month; total rainfall; days rain > .1 in.; heating and cooling degree days; days high > 90; days low < 32; days low temp. < 32 and > 0; days low < 0; day of highest range. Also retrieves a single day from data file for review. All data outputs to printer. Well documented.

16K Extended . . . . . \$24.95

## Forecaster & Weather Watch (Disk)

Forecast general weather conditions with 80% accuracy with this fun, simple to use program. Although not meant to replace National Weather Service forecasts, this program is informative and enjoyable to use. You can even create your own weather by setting the variables!! Provides general forecast including precipitation probabilities. Includes Weather Watch program also all on one easy to use disk.

32K Extended Disk . . . . . \$49.95

Inspector  
Cheseau



Sherlock Holmes/Agatha Christie fans-It's finally here—A murder mystery game for the 80-C! Mr. Goodbody has been killed in his mansion and you must solve the mystery. WHO committed the murder, WHERE did it occur and HOW was it done! Question suspects, find the secret passage, and break the code to get clues. Hi-Res graphics enhances this excellent game. The computer records the clues you obtain on a clue inventory screen and also provides suspect descriptions at the touch of a finger. A fast, fun game that will sharpen your deductive skills. Every game is different!

32K Extended . . . . . \$19.95

AVAILABLE MAY 1

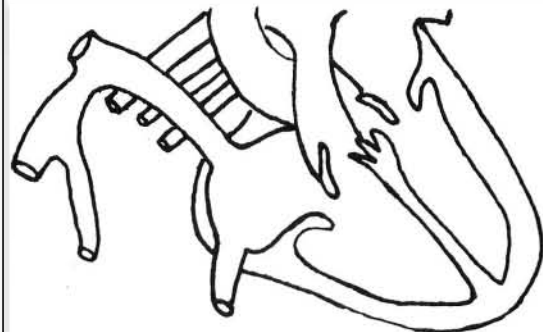

HEART - LUNG - CIRCULATORY  
SYSTEMS

Include \$1.50 for handling for each program.  
Az. Residents add 6% Sales Tax.  
Quantity Discounts to Dealers.

CIS subscribers contact through EMAIL 70435,754



**PETROCCI FREELANCE ASSOCIATES**

651 N. Houghton Rd.  
Tucson, AZ. 85748  
602-296-1041



```

ND MORE"
112 PRINT "THAN YOU HAVE."
113 GOSUB 371
114 GOTO 138
115 ' CONTINUE OLD GAME
116 CLS: I=0
117 PRINT "HI! WELCOME BACK TO"
118 PRINT "LEMONSVILLE. LET'S C
ONTUNUE"
119 PRINT "YOUR LAST GAME WHERE
YOU LEFT"
120 PRINT "IT. DO YOU REMEMBER
WHAT DAY"
121 PRINT "NUMBER IT WAS";
122 INPUT A$: A=VAL(A$): PRINT:
IF A<>0 THEN 126
123 A$=LEFT$(A$,1): IF A$="Y" TH
EN PRINT "WHAT DAY WAS IT";: I=I
+1: GOTO 122
124 IF A$="N" OR I>0 THEN 128
125 PRINT "YES OR NO?": I=I+1: G
OTO 122
126 IF A<1 OR A>99 OR A<>INT(A)
THEN 128
127 D=A
128 PRINT "OK - WE'LL START WITH
DAY" D+1: PRINT
129 FOR I=1 TO N: PRINT
130 PRINT "PLAYER" I "HOW MUCH M
ONEY"

```

```

131 PRINT "(ASSETS) DID YOU HAVE
";
132 INPUT A$: A=VAL(A$): PRINT
133 IF A<2 THEN PRINT "OK - WE'L
L START YOU OUT WITH $2.00": A
=2: GOTO 135
134 IF A>40 THEN PRINT "JUST TO
BE FAIR, LET'S MAKE THAT $10
.00": A=10
135 A(I)=INT(A*100+.5)/100: NEXT
136 PRINT: INPUT " ...READ
Y TO BEGIN"; A$
137 IF LEFT$(A$,1)="N" THEN 79
138 ' WEATHER REPORT
139 SC=RND(0)
140 IF SC<.6 THEN SC=2: GOTO 143
141 IF SC<.8 THEN SC=10: GOTO 14
3
142 SC=7
143 IF D<3 THEN SC=2
144 GOSUB 316
145 CLS
146 ' START OF NEW DAY
147 D=D+1
148 PRINT "ON DAY" D "THE COST O
F"
149 PRINT "LEMONADE IS ";
150 C=2: IF D>2 THEN C=4
151 IF D>6 THEN C=5
152 C1=C*.01
153 PRINT USING "$$.##"; C1
154 R1=1
155 ' CURRENT EVENTS
156 IF D<>3 THEN 158
157 PRINT "(YOUR MOTHER QUIT GIV
ING YOU FREE SUGAR)"
158 IF D<>7 THEN 160
159 PRINT "(THE PRICE OF LEMONS
WENT UP)"
160 ' THINGS HAPPEN AFTER DAY 2
161 IF D>2 THEN 271
162 ' INPUT VALUES
163 PRINT
164 FOR I=1 TO N
165 G(I)=1: H(I)=0
166 PRINT "STAND" I; TAB(16) "AS
SETS ";: PRINT USING "$####.##";
A(I)
167 PRINT
168 IF B(I)=0 THEN 172
169 PRINT "YOU'RE BANKRUPT! NO
DECISIONS."
170 IF N=1 AND A(1)<C THEN 312
171 GOTO 211
172 PRINT "HOW MANY GLASSES OF L
EMONADE DO YOU WANT TO MAKE";
173 INPUT L(I)
174 IF L(I)<0 OR L(I)>1000 THEN
176
175 GOTO 178

```

## COMPUTER BUSINESS FORMS

Continuous forms, labels, paper, checks, invoices, statements—all with your imprint. Continuous letterhead with a perf so fine that you need a magnifying glass to tell it's a fan fold sheet. Matching envelopes.

Regular letterhead, business forms and cards also.

Send sample for quote. Send \$3.00 (refundable on first order) for our catalog.

Catalog also includes computer furniture.

### DESERT PRESS, INC.

P. O. Box 15128  
Las Vegas, Nevada 89114

## The PROFESSIONAL Keyboard

See review in March '83 RAINBOW, page 20

No soldering, cutting, or gluing required - plugs right in!

**\$89.95**



The Color Computer Professional Keyboard, with full stroke, positive action keyswitches, provides a feel normally associated with more expensive microcomputers and terminals. The finely textured keycaps, gray and black with white lettering, nicely complement the Color Computer's sleek appearance. And, the keyboard's high quality construction assures years of reliable operation. A 90-day limited warranty is provided. The four function keys, occupying the extra positions in the keyboard matrix, are an added bonus. Whether with your own software, or with that from vendors who have specially adapted theirs, (such as Frank Hogg Laboratories' FLEX), the function keys enhance the keyboard's utility. BASIC programming examples and assembly language driver listings are included. The keyboard is custom made for the Color Computer by Macrotron, an experienced manufacturer of computer components and peripherals. Consequently, installation is a simple plug-in operation, requiring no soldering or cutting whatsoever. The installation procedure is detailed in an illustrated user's manual, which is included but also available separately for \$2.00 (refundable with purchase). Two versions of the keyboard are available, one for revision E and earlier Color Computers and the other for the revision F (also known as A or ET) Color and TDP-100 computers. Please specify which version you have when ordering, if possible. Otherwise, include the complete catalog number and serial number.

### **Micronix Systems Corporation**

#7 Gibraltar Square  
St. Charles, MO 63301  
(314) 441-1694

Terms: Prepaid check or money order, Mastercard or Visa.  
Shipping Charges: U.S. \$2.00, Canada \$4.00, COD \$3.50 (No COD's to Canada).



```

176 PRINT "LET'S BE REASONABLE.
TRY AGAIN.";
177 GOTO 172
178 IF L(I)<>INT(L(I)) THEN 176
179 IF L(I)*C1<=A(I) THEN 187
180 PRINT "YOU HAVE ONLY";
181 PRINT USING "$###.##"; A(I)
;
182 PRINT " IN CASH."
183 PRINT "TO MAKE"; L(I) "GLASS
ES OF"
184 PRINT "LEMONADE, YOU NEED";
185 PRINT USING "$###.##"; L(I)
*C1;: PRINT "."
186 GOTO 172
187 PRINT
188 PRINT "HOW MANY SIGNS (";:PR
INT USING "## "; S3*100;:PRINT "
CENTS"
189 PRINT "EACH) DO YOU WANT";
190 INPUT S(I)
191 IF S(I) <0 OR S(I) >50 THEN
193
192 GOTO 195
193 PRINT "BE REASONABLE. TRY A
GAIN."
194 GOTO 187
195 IF S(I)<>INT(S(I)) THEN 193
196 IF S(I)*S3<=A(I)-L(I)*C1 THE

```

```

N 202
197 PRINT
198 PRINT "SORRY, YOU HAVE ONLY"
;
199 PRINT USING "$###.##"; A(I)
-L(I)*C1
200 PRINT "AFTER MAKING YOUR LEM
ONADE."
201 GOTO 187
202 PRINT: PRINT "WHAT PRICE ARE
YOU CHARGING FOR"
203 PRINT "FOR EACH GLASS (IN CE
NTS)";
204 INPUT P(I)
205 IF P(I)<0 OR P(I)>99 THEN 20
7
206 GOTO 209
207 PRINT:PRINT "BE REASONABLE.
TRY AGAIN."
208 GOTO 202
209 IF P(I)<>INT(P(I)) THEN 207
210 IF C5=1 THEN 211
211 PRINT: INPUT "WANT TO CHANGE
ANYTHING"; A$
212 IF LEFT$(A$,1)="Y" THEN CLS:
C5=1: GOTO 165
213 CLS
214 NEXT I
215 C5=0: CLS
216 IF SC=10 AND RND(0)<.25 THEN
296
217 PRINT " LEMONSVILLE FINANCI
AL REPORT"
218 PLAY MONEYSONG$
219 ' CALCULATE PROFITS
220 IF R2=2 THEN 292
221 IF R3=3 THEN 301
222 FOR I=1 TO N
223 IF A(I)<0 THEN A(I)=0
224 IF R2=2 THEN 234
225 IF P(I)>=P9 THEN 228
226 N1=(P9-P(I))/P9*.8*S2+S2
227 GOTO 229
228 N1=((P9^2)*S2/P(I)^2)
229 W=-S(I)*C9
230 V=1-(EXP(W)*C2)
231 N2=R1*(N1+(N1*V))
232 N2=INT(N2*G(I))
233 IF N2<=L(I) THEN 235 'SALE
S >= PRODUCTION
234 N2=L(I)
235 M=N2*P(I)*.01
236 E=S(I)*S3+L(I)*C1
237 P1=M-E 'PROFIT
238 A(I)=A(I)+P1
239 IF H(I)=1 THEN 296
240 IF I>1 THEN PRINT " LEMONSV
ILLE FINANCIAL REPORT"
241 PRINT

```

**NOW a good used line printer  
CENTRONICS 588**

132 characters per line  
Sprocket feed - Adjustable width  
Dot Matrix 5 X 7  
Print rate 88 char. per second  
One line buffer  
H = 13-3/4" D = 21-2/3"  
W = 32" Weight = 98 lbs.

CENTRONICS 588 (used) serial 600  
Baud, with 4 pin DIN plug \$315.00

CENTRONICS 588 (used) parallel feed  
44 pin edge card \$275.00

All prices F.O.B. Henderson, Tx.  
Terms: Cash, check or COD  
Tx. residents add 4% sales tax

LEADER SALES CORPORATION  
P.O. Box 1220, Henderson, Tx. 75653  
Ph. 214-657-7800 after 6 PM  
Discounts available to CC Clubs and  
volume buyers.

# JUST GOOD SOFTWARE

REVIEW DATES  
\*RAINBOW  
\*JAN '83

**DISK DOUBLE ENTRY** - If you have spent hours trying to balance your Debits and Credits, this program is for you! Designed for small business, club, and personal use. Enter transactions in a journal type format. Program will maintain current account balances, produce Trial Balance, Income, and Balance Sheet reports and complete Account Ledgers. Will handle up to 300 accounts including report headings and totals. Up to 1400 average transactions on a diskette. Summary reports and four levels of subtotals available. REQUIRES 32K and a user understanding of standard double entry accounting concepts. - \$44.95 in BASIC with Machine Language subroutines.

**DISK DATA HANDLER - 64K** - Designed to use the full 64K RAM, but may also be configured for 32K. Uses standard ROM's - No special operating system required! Allows you to design disk data files for your specific needs. You define a basic record of up to 14 fields and 246 characters. Provides fast selection and sorting based on any field or combination of fields in this record. Powerful on-screen input and update. User defined output of reports to screen, printer, or disk files which may be read by your BASIC programs for any computational or special formatting requirements. Printer reports allow headings, page breaks, and page numbering, and let you pass control codes to drive your printer's special features. Maximum number of records you may work with at one time will depend on RAM configuration and record size - 64K (32K) 1850 (500) - 21 char records, 179 (49) - 246 char records. An optional Extended record linked to the basic record may also be defined. The size of this Extended record is not a factor in determining maximum number of records. Will provide the growth capability needed for your increasingly sophisticated applications. \$54.95 in BASIC with Machine Language subroutines.

\*OCT '82

**DISK DATA HANDLER - 32K only version** - as above, but without report headings, page breaks, or printer control codes. \$44.95

**DATE-O-BASE CALENDAR** - Puts you in charge of your schedule! Graphically displays any monthly calendar between 1700 and 2099. You put in up to twelve 28 character memos per day - calendar shows where the memos are - call up of day shows details. Use for appointments and a log of past activity. Study the chronology of the American Revolution or note the day your mortgage will be paid off. Search capability allows you to list or print all memos between two specified dates or only ones meeting key word criteria. Date computation shows elapsed time between two dates in days, weeks, months, and years. REQUIRES 32K in BASIC.

\*JUNE '82

TAPE DATE-O-BASE CALENDAR - \$16.95  
(max. 400 memos/tape file)

DISK DATE-O-BASE CALENDAR - \$19.95  
(over 4,000 memos/disk - max. 300 memos/month)

**MATH TUTOR** - Five programs that go from math fact (+, -, X, /) drill to full addition, subtraction, multiplication, and division at four levels of difficulty. Provides a step by step approach with error correction and rewards for good performance. - \$13.95 in BASIC.

\*SEP '82

**SPELLING TEACHER** - Up to 200 of their spelling words stored on tape or disk are presented in four lively study modes including a scrambled word game. - \$12.95 in BASIC.

\*SEP '82

**ALPHA-DRAW** - A subroutine designed to let you easily add characters to your graphic displays. You define X and Y coordinates and a string variable of one or more characters and Alpha-Draw will do the rest. Includes all keyboard characters. Comes with instructions for a true line numbered merge of tape files. Works great with the Screen Print program! - \$8.95 in BASIC.

\*AUG '82

**GRAPHIC SCREEN PRINT PROGRAM** - Works in ALL PMODES and lets you shift screen image anywhere on the printed page. Relocatable code lets you use all of your 16K or 32K machine. Available for both Color Basic 1.0 and 1.1. Use EXEC 41175 to see which you have and SPECIFY with order. In Machine Language.

\*MAY '82

\$7.95 - For TRS-80® LP-VII/VIII & DMP 100/200/400

(specify printer type)

\$9.95 - For Epson GRAFTRAX®, PROWRITER®, NEC® PC 8023A-C

Microline® 82A/83A (with OKIGRAPH® I), Microline 84

IDS-440/445, Paper Tiger® 460/560, Micro Prism® 480, Prism® 80/132 (with dot plotting)

Micro Peripherals, Inc. 88G/99G

(Trademarks of Tandy Corp., Epson America, Inc., C-Itch, NEC America, Okidata Corp., Integral Data Systems, Inc.)

ALL PROGRAMS require Extended Color Basic and are delivered on cassette. All, except Tape Date-O-Base Calendar, are DISK System compatible.

*We want your  
SUGGESTIONS!*

## Custom Software Engineering, Inc.

807 Minutemen Causeway (D-2), Cocoa Beach, Florida 32931  
(305) 783-1083



For VISA and Master Card orders:  
Include type, account number, expiration date, signature and phone number.  
Sorry! No COD's.

Add \$1.00 per order for shipping. Florida residents add 5% sales tax. Return within two weeks if not completely satisfied.



**RAINBOW  
CERTIFICATION  
SEAL**  
ALL LISTED  
PROGRAMS



```

242 IF B(I)<>1 THEN 245
243 PRINT "STAND" I "BANKRUPT":
GOSUB 371
244 GOTO 267
245 PRINT " DAY" D TAB(22) "STA
ND" I: PRINT
246 PRINT USING " #### "; N2;: P
RINT "GLASSES SOLD"
247 PRINT " $.";: IF P(I)<10 THE
N 248 ELSE PRINT USING "## "; P(
I);: GOTO 249
248 PRINT "0";: PRINT USING "# "
; P(I);
249 PRINT "PER GLASS"
250 PRINT TAB(15) "INCOME";: PRI
NT USING "$#####.##"; M
251 PRINT: PRINT USING " #### ";
L(I);: PRINT "GLASSES MADE"
252 PRINT USING " #### "; S(I);:
PRINT "SIGNS MADE"
253 PRINT TAB(13) "EXPENSES";: P
RINT USING "$#####.##"; E
254 PRINT: PRINT TAB(15) "PROFIT
";: PRINT USING "$#####.##"; P1
255 PRINT: PRINT TAB(15) "ASSETS
";: PRINT USING "$#####.##"; A(I
)
256 GOSUB 371
257 CLS

```

```

258 IF A(I)>C/100 THEN 267
259 PRINT "STAND" I
260 PRINT " ... YOU DON'T HAVE E
NOUGH MONEY";
261 PRINT "LEFT TO STAY IN BUSIN
ESS."
262 PRINT "YOU'RE BANKRUPT!"
263 PLAY BANKRUPT$
264 B(I)=1
265 GOSUB 371: CLS
266 IF N=1 AND B(1)=1 THEN 312
267 NEXT I
268 R1=1
269 R2=0
270 GOTO 138
271 ' RANDOM EVENTS
272 IF SC=10 THEN 277
273 IF SC=7 THEN 308
274 IF RND(0)<.25 THEN 283
275 GOTO 163
276 IF X1=1 THEN 163
277 J=30+INT(RND(0)*5)*10
278 PRINT "THERE IS A";:PRINT US
ING " ##"; J;:PRINT "% CHANCE OF
RAIN"
279 R1=1-J/100
280 X1=1
281 GOTO 163
282 IF X2=1 THEN 163
283 PRINT "THE STREET DEPT. IS W
ORKING ON"
284 PRINT "YOUR STREET AND THERE
WILL BE"
285 PRINT "NO TRAFFIC TODAY."
286 IF RND(0)<.5 THEN 289
287 R2=2
288 GOTO 290
289 R1=.1
290 X2=1
291 GOTO 163
292 PRINT "THE STREET CREWS BOUG
HT ALL YOUR";
293 PRINT "LEMONADE AT LUNCH TIM
E!"
294 FS=1:GOSUB 367
295 GOTO 222
296 ' THUNDERSTORM
297 X3=1:R3=0
298 SC=5:GOSUB 316:CLS
299 PRINT "WEATHER REPORT: A SE
VERE"
300 PRINT "THUNDERSTORM HIT LEMO
NSVILLE"
301 PRINT "TODAY JUST AS THE LEM
ONADE"
302 PRINT "STANDS WERE BEING SET
UP."
303 PRINT "EVERYTHING WAS RUINED
!"

```

**NEW** **ADVANCED MATH PROGRAMS**  
for  
**ENGINEERS • PHYSICISTS • STUDENTS**

**FUNCTION GRAPHING MODULE 16K EXT-\$19.95**

- \* HIGH RESOLUTION GRAPHS
- \* GRAPH ANY FUNCTION — 4 AT ONCE
- \* PARAMETERS EASY TO CHANGE
- \* AUTO-SCALING OPTIMIZES GRAPH SIZE
- \* FIND AND COMPUTE FUNCTION VALUES & ZEROS
- \* INTERSECTION OF FUNCTIONS
- \* COMPLETE MANUAL — PROGRAM ON TAPE

**CALCULUS MATH MODULE 32K EXT-\$34.95**

- \* STARTS WITH THE GRAPHING MODULE
- \* LOAD UP 9 FUNCTIONS AT ONCE
- \* FIND AND COMPUTE MAXIMA & MINIMA
- \* NUMERIC INTEGRATION & DIFFERENTIATION
- \* COMPOSITE AREAS
- \* HANDLES PIECEWISE CONTINUOUS FUNCTIONS
- \* HARD COPIES OF DATA AND/OR GRAPH
- \* COMPLETE MANUAL — PROGRAM ON TAPE

**CALCSOFT**  
P.O. BOX 401  
ST. ANN, MO 63074

CHECK OR MONEY ORDER — \$1.00 for shipping

# AT LAST - REAL ARCADE ACTION SOFTWARE

Just plug in our adaptor (below) and use your ATARI® JOYSTICKS, or for REAL ARCADE ACTION...get one of ours!  
By WICO®



COMMAND CONTROL adaptor Radla Shock® TRS80® Color Computer 17<sup>95</sup>  
Use one or two joysticks - Adaptor needed for all joysticks.

## COMMAND CONTROL Joysticks

- Injection-molded modular construction and 6 Leaf type molded switches — identical to the best commercial arcade models.
- Two fire button locations, activated by above-mounted slide switch
- Extra-long 5' cord



**Famous Red Ball™**  
Joystick 15-9730 34<sup>95</sup>

- Arcade-type red ball handle that moves smoothly and easily into all 8 standard positions.

- Low-profile, heavy-duty plastic base.



**Joystick 15-9714 29<sup>95</sup>**

- Extra-long arcade style bar handle grip that moves smoothly and easily into all 8 standard positions.

- Low-profile, heavy-duty plastic base.



ATARI  
Joysticks

**SPECIAL**  
\$9.50 each/2 for \$18.00

## QuickShot™ DELUXE JOYSTICK CONTROLLER

- Deluxe positive response fire button
  - Contour grip design ● Extra long feet cord
  - Conventional type firing button ● Rubber Suction cup footing for stable one hand operation ● Contour groove for sure grip
- \$19<sup>95</sup> ea./34<sup>95</sup> pr.



## TRIGA-COMMAND JOYSTICKS

\$19<sup>95</sup> ea./34<sup>95</sup> pr.



**POINTMASTER 17<sup>95</sup> ea./32<sup>95</sup> pr.**

A rugged, fast action joystick for those who take their games seriously.

**POINTMASTER PRO 28<sup>95</sup>ea./49<sup>95</sup> pr.**

Super Joystick with built in Fire Control and suction base.

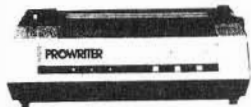

## Pro/Writer Printer—8510 A

	LIST	SALE	PACKAGE	VISA/MC add 3%
Printer	\$495.00	\$439.95	Package \$499.95	Ship/handling & insurance add \$10.00
Interface	69.00	65.95		
TDP-100				

16K Color Computer w/BASIC - \$289.00  
16K Color Computer w/Extended Color BASIC - \$389.00

## FROM SHELL

**DEATHSTAR** "an adventure" 32k/ecb. \$19.95  
a text adventure thats different!!  
(See review in April Issue of Rainbow)

**SUB-HUNT** "arcade type" 16k/ecb . . . \$ 9.95  
(FREE in March Issue of Rainbow)

**STAR RAID** "arcade type" 16k/ecb . . . \$18.95  
a lot of action for 16k

**FEDERATION BOOTCAMP** 16k/ecb . . . \$18.95  
You've been drafted for 16 wks.  
of rugged training! can you  
become a "space cadet"???

**SONAR SEARCH** "arcade type" 16/ecb \$18.95  
remember battleship?? you'll  
love this one! 1/2 players

**EXTERMINATOR** "arcade type" 16k/ecb \$18.95  
not a "centipede type game"  
this is original! destroy  
the insects with your can  
of "RAID" - lots of fun!

**SNOOPY & RED BARON** "arcade type" \$18.95  
16k/ecb - this one is a real  
"dog fight" for 2 players only!

**LUNAR-lander** "arcade type" 16k/ecb \$15.95  
yep, another "lander" game but  
we think you'll like our version.  
Different each time with 4 levels  
of play! Great Effects!!

## FROM TOM MIX

**DONKEY-KING** "arcade type" 32k/ml \$24.95  
by far the best "KONG" type  
game! 4 full screens, just  
like the arcade-ASTOUNDING!!

**TAPE TO DISK** "utility" 16k/ml . . . . . \$19.95  
load any tape to disk  
automatically

**THE FIXER** "utility" 16k/ml . . . . . \$18.95  
having trouble moving those  
600 hex programs to disk?  
the FIXER will help!

**DISK TO TAPE** "utility" 16k/ml . . . . . \$19.95  
dump contents of disk to  
tape automatically

\*\*\*IF IT'S NOT GOOD, WE DON'T SELL IT\*\*\*  
DEALER INQUIRIES WELCOME

\* ALL ARCADE TYPE IN HI-RES \*

**ZAXXON** By Datasoft, 32K... \$32.95

FREE 16K Adv. game with  
\$50 order.

## S & S ARCADE SUPPLIES

8301 Samow Dr./Orlando, FL 32807  
9 to 5 EST (305) 894-1887 - Evenings (305) 275-8490

Orders under \$50 - add \$2.50  
ship/hnd. Write for complete  
line of software.  
Fla. residents add 5% sales tax.  
VISA/MC add 3%



Buy a disk drive for  
your Co-Co that's  
better and saves  
you money!

**TANDON 40trk DISK DRIVES**

DRIVE 0 \$449.      DRIVE 1 \$249.  
DRIVE 0&1 \$669. (dual case and power supply)

**Double Sided 40trk TANDON Drives**

DRIVE 0/1 \$549      DRIVE 2/3 \$349.  
DRIVE 0/1/2/3 \$869. (dual case)

WICO COCO TRACKBALL \$69.

WICO JOYSTICK \$24.95

16K CHIP SET \$14.95

64K CHIP SET (8) \$64.

JCAT AUTO/ANSWER MODEM \$139.

Since this ad was formatted in January  
printer prices were expected to go  
down, please call our toll free number  
for the latest pricing and availability.

48K 2 DRIVE MODEL III \$1695.

**120 Day Warranty**

Visa , MasterCard , Money Orders , Personal Checks

Require 3 Weeks , and Wire Transfers.

**COMPUKIT**

1-800-231-6671

1-713-480-6000

16206D Hickory Knoll Houston, Texas 77059

```

304 FS=1:GOSUB 367
305 FOR J=1 TO N:G(J)=0:NEXT
306 GOTO 222
307 IF X4=1 THEN 163
308 X4=1
309 PRINT "A HEAT WAVE IS PREDIC
TED TODAY!"
310 R1=2
311 GOTO 163
312 FOR I=1 TO 2000: NEXT: CLS:
PRINT@256, "WOULD YOU LIKE TO PL
AY AGAIN?"
313 INPUT IN$: IN$=LEFT$(IN$,1):
IF IN$="Y" THEN 47
314 CLS
315 END
316 ' WEATHER DISPLAY
317 CLS3
318 PRINT@416,STRING$(64,143)
319 PRINT@144,CHR$(128);"lemonad
e";CHR$(128);
320 PRINT@176,CHR$(128);"for";CH
R$(128);"sale";CHR$(128);
321 FOR LO=208 TO 272 STEP 32: P
RINT@LO, CHR$(165);: NEXT
322 FOR LO=217 TO 281 STEP 32: P
RINT@LO, CHR$(170);: NEXT
323 FOR LO=304 TO 400 STEP 32: P
RINT@LO, STRING$(10,128);: NEXT
324 FOR LO=274 TO 278 STEP 2: PR
INT@LO, CHR$(159);: NEXT
325 PRINT@480,"WEATHER REPORT:";
326 IF SC=5 THEN 344
327 PRINT@36, STRING$(5,255);
328 PRINT@67, STRING$(7,255);
329 PRINT@99, STRING$(7,255);
330 PRINT@132, STRING$(5,255);
331 IF SC<>2 THEN 334
332 PRINT@496, "SUNNY";: PLAY SU
NSONG$
333 RETURN
334 IF SC<>7 THEN 337
335 PRINT@496, "HOT AND DRY";: P
LAY HOTSONG$
336 RETURN
337 PRINT@51, STRING$(10,207);
338 PRINT@82, STRING$(12,207);
339 PRINT@116, STRING$(11,207);
340 PRINT@154, STRING$(4,207);
341 PRINT@186, STRING$(2,207);
342 PRINT@496, "CLOUDY & COOLER"
;: PLAY CLOUDSONG$
343 RETURN
344 PRINT@33, STRING$(13,128);ST
RING$(2,175);STRING$(13,128);
345 PRINT@67, STRING$(12,128);ST
RING$(3,175);STRING$(12,128);
346 PRINT@99, STRING$(11,128);ST
RING$(6,175);STRING$(11,128);

```

```

347 PRINT@133, STRING$(8, 128);
348 PRINT@154, STRING$(4, 128);
349 PRINT@167, STRING$(5, 128);
350 PRINT@496, "THUNDERSTORMS";:
  PLAY RAINSONG$
351 FOR LO=1 TO 2
352 FOR DE=1 TO 123: READ J: NEX
T
353 FOR DE=1 TO 18
354 READ I,J
355 POKE I,J
356 NEXT
357 FOR DE=1 TO 40: NEXT
358 FOR DE=1 TO 18
359 READ I,J
360 POKE I,J
361 NEXT
362 RESTORE
363 NEXT LO
364 RETURN
365 DATA 1160,207,1192,207,1225,
207,1258,207,1291,207,1323,207,1
356,207,1160,128,1389,207,1192,1
28,1422,207,1225,175,1258,175,12
91,175,1323,175,1356,175,1389,17
5,1422,143
366 DATA 1145,207,1178,207,1211,
207,1244,207,1276,207,1309,207,1
145,128,1341,207,1178,128,1373,2

```

```

07,1211,175,1406,207,1244,175,12
76,175,1309,175,1341,175,1373,17
5,1406,175
367 PRINT@480, "push c to cont
inue ";: FOR QP=1527TO1534:POK
EQP,32:NEXT : POKE 1508,32: POKE
1509,27: POKE 1511,29: POKE 151
2,32: POKE 1515,32: POKE1524,46:
POKE1525,46: POKE1526,46: POKE1
535,32
368 IN$=INKEY$:IF IN$<>"C" THEN
368
369 IF FS=1 THEN CLS:PRINT " LE
MONSVILLE FINANCIAL REPORT" ELSE
RETURN
370 FS=0:RETURN
371 '
372 PRINT@480, "push c to cont
inue e to en";: POKE 1508,32:
POKE 1509,27: POKE 1511,29: POK
E 1512,32: POKE 1515,32: POKE 15
24,44: POKE 1525,32: POKE 1526,2
7: POKE 1528,29: POKE 1529,32: P
OKE 1532,32: POKE 1535,4
373 IN$=INKEY$:DE=RND(-TIMER)
374 IF IN$="E" THEN 312
375 IF IN$="C" THEN RETURN
376 GOTO 373

```



# PRISM



ARCADE GAMES

Dealer Inquiries welcome  
Quality color computer software  
All Software on tape only  
All games require 16 K except  
where noted

## ★ By Spectral Associates ★

GHOST GOBBLER	\$26.95	ROBOT BATTLE	\$26.95
ALCATRAZ II	\$11.95	PLANET INVASION	\$26.95
GALAX ATTAX	\$26.95	COSMIC INVADERS	\$26.95
SPACE WAR	\$26.95	SPACE RACE	\$26.95
KEYS OF THE WIZARD	\$23.95	DEFENSE	\$26.95

## ★ By Mark Data Products ★

BLACK SANCTUM	\$28.95	ASTRO-BLAST	\$30.95
CAVE HUNTER	\$28.95	CALIXTO ISLAND	\$28.95
BERSERK	\$30.95	SPACE RAIDERS	\$30.95

## ★ By Computerware ★

COLOR PAC ATTACK	\$30.95	STARSHIP	
DOODLEBUG	\$30.95	CHAMELEON	\$30.95
RAIL RUNNER	\$30.95	STORM	\$30.95



## ★ By Intracolor ★

COLORPEDE	\$35.95
-----------	---------



## ★ By Tom Mix Software ★

DONKEY KING	\$30.95
-------------	---------



requires 32 K

# Prism Software

CHOPPER RESCUE	(Extended BASIC)	\$13.95
LAS VEGAS	(Extended BASIC)	\$11.95
THE ALIEN		\$13.95

RAIDERS "By Prism Software" In this adventure you must deal with voodoo curses, alligators, ancient traps and hostile natives. This adventure begins in the confusion of a large city and ends (maybe too soon if you're not careful) in a dangerous, dense jungle in South America.  
(Extended BASIC) \$16.95



## Prism Software

779 Queen St.,  
Box 1360, Kincardine,  
Ontario, Canada. N0G 2G0  
Tel:(519)396-8224

Add 5% for shipping  
No C.O.D.  
VISA or Mastercard accepted  
Ontario residents add 7% sales tax.

Please allow

2-3 weeks for delivery



## Catch 'Em Can Be Catching— Especially For The Young

Ever try juggling more than two balls over your head at the same time? (Hasn't everybody?) That's the kind of feeling you get while playing *Catch 'Em* the first few times through, except that you're trying to keep up with 16 objects wave after wave after wave...

The game, which requires 16K—no Extended BASIC, is deceptively easy through the first five waves, as you maneuver your joystick frantically back and forth catching the missiles in a barrel. But, as you gain in confidence, you also tend to be lackadaisical—and that's when you get in trouble! Splat, the missile hits the bottom of the screen, and the sound effects, combined with the flashing lights, shock you back into reality.

The assortment of objects in *Catch 'Em* includes a crazy collection of thimbles, rockets, flying saucers, Thai fighters, balls, even a Flying I!

You are given three opportunities to catch them and, if successful, you are rewarded with extra barrels. Your running score is displayed at the upper lefthand side of the screen.

If you are not an immediate success, simply pressing the "R" key enables you to sharpen your skills with a new game.

While grownups may want to go on to something "more challenging" (especially if they are continually frustrated), the youngsters will love *Catch 'Em*. For teaching them hand-to-eye coordination, or dexterity with the joystick, there's no better way than with *Catch 'Em*.

(Aardvark-80, 2352 S. Commerce, Walled Lake, Mi 48088, \$19.95 on tape)

—Charles Springer

## Doubleback: New 4K Game Is Challenging, Fun

One day in early March, a package which piqued my curiosity arrived at the Prospect offices of *the Rainbow*. My sixth sense told me there was something inside of extraordinary interest. The red and white label told me it was from Radio Shack.

Thumbing through the colorful catalogs, slick, hard-bound documentation folders, ROM Paks and tapes, I sought to lay hold of that quantity I knew (or maybe just hoped) was there. Most of the stuff I had seen before—Color SCRIPSIT, Color Disk Spectaculator, Bustout—all good programs, too, but where was *IT*? That *bon d' CoCo*? An instant later I would learn that I was but a handful of Styrofoam pellets away from the answer.

There it was. *Doubleback!*

*Doubleback?* Could it be? It was a brand new release from Radio Shack, but right there on page one of the documentation booklet it said all the system it required was 4K RAM and joysticks. Not 16K, not 32K, no Extended Color BASIC—just 4K.

Of course, you have to play *Doubleback* before you can really appreciate its economy of programming. It is a thoroughly absorbing—even addictive—game with very nice graphics, well-done sound effects that add to the fun without getting in the way, a challenging scoring system, and a concept that is unique, bizarre and non-violent. It's a great game for kids, if the little things can ever wrestle control from the clutches of their parents. Fortunately for my daughter Laura, two can play the game as well as one, or her mother, who may be the world's first *Doubleback* junkie, would never give her a chance to experience more than the vicarious, second-hand joy that belongs to the spectator.

Just what is it that makes this small program such great fun? Good question. A part of the answer, I feel, lies in the greater sense of control you have over the field of play. That's just a guess. It might be the residual trail that you trace with your joystick, or the mysterious suddenness with which the mystical objects materialize in the field, or the progression of difficulty as your score mounts. Whatever it is, it is a real quantity.

To play *Doubleback*, you patrol the area by moving the joystick to trace a colorful, fading contrail on the screen. As an assortment of objects pops into view, you attempt to circle them, making a complete loop with your trail before it fades. Catching two or more objects in your loop derives bonus points for your score.

Your turn is suddenly terminated when you collide with an object you're trying to circle, or another which might have just popped into your path. Certain objects, like spiders, move on the screen; others appear only after you have reached various threshold point levels. If you have done so well as to have offended the program master, you will encounter something to slow you down—skulls. Beginning with one and increasing in number up to 10, the skulls appear. They have no point value, they're only there as obstacles to keep you from circling your quarry and to bring your turn to an abrupt halt as you run into them. And, although I haven't encountered it, a warning in the documentation booklet which comes boxed with this ROM Pak states that after 10 skulls you must beware of the unexpected. The context of the word "unexpected" makes me very curious, as the game *Doubleback* is itself a composite of unexpected elements. *Doubleback* is a 4K gem.

(Available at Radio Shack, Cat. No. 26-3091, \$24.95)

—Courtney Noe

### TRS-80 COLOR BASIC

by BOB ALBRECHT

*Beginners*

This entertaining self-instructional book is packed with games, experiments, scores of intriguing challenges, and activities related to fantasy role-playing games. The ideal introductory aid for kids, parents and teachers using the Color Computer.

John Wiley & Sons  
605 Third Ave., New York, NY 10158

\$9.95

### TRS-80 COLOR COMPUTER GRAPHICS

by DON INMAN

*Intermediate*

Explore the creative and imaginative blending of computers and color. This exciting book will enable you to explore all the graphics capabilities of Extended Color BASIC.

Reston Publishing Company  
11480 Sunset Hills Rd., Reston, VA 22090

\$14.95

### ASSEMBLY LANGUAGE GRAPHICS FOR THE TRS-80 COLOR COMPUTER

by DON INMAN and KURT INMAN

*Advanced*

This book is specific to the TRS-80 Color Computer with applications using sound and graphics to illustrate how an assembler can be used to perform feats that would be quite difficult, if not impossible in the BASIC language.

Reston Publishing Company

\$14.95

### DYMAX, P.O. 310, MENLO PARK, CA 94025

Dymax orders must be prepaid via check, money order, Visa or Mastercard. Sorry, no Purchase Orders or COD orders. Please add \$2.00 shipping and handling. California residents add 6% sales tax.



## Make This Handy Reusable Graphics Grid

By T. Gray

Planning and plotting graphics, whether on the 80C or another computer, is a time-consuming process requiring a number of sketches. Here are some ideas for making this programming step a bit easier.

The most obvious thing to do is to have the *PRINT@* locations and graphics grid (pages 277-278 in the Color Basic Manual) photocopied. A hundred of these will last a fair while and will provide for many a program. Since such photocopying appears to violate copyright laws, I'm surprised that Radio Shack doesn't supply these grids in newsprint pads.

An elegant solution is to get one of those "magic slates"—the kind where lifting the transparent cover erases the image. From a stationary store, graphic arts supply house, or teachers' store, get a couple of non-washable felt tip pens for writing on acetate (transparencies for overhead projectors). Use the felt pens to draw your *PRINT@* or graphics grid onto the acetate cover of the "magic slate." This will give you

a quickly erasable practice sheet for sketching graphics, centering titles or instructions, etc.

A third suggestion is to buy a set of *washable* acetate felt pens in the eight colors of your 80C. You can use these in either of two ways. If you like, you can have an acetate transparency of your grids made (any office with a modern photocopier can do this; or try a printing or photocopying film). You can then sketch in copy or full-color graphics, and erase them with a damp paper towel. An alternative method is to simply tape a clear acetate sheet (readily available at graphics firms, or as page protectors or photo album inserts at drug stores) over the appropriate grid in your manual. The image can be easily moved to different locations on the grid without the need for redrawing. Complete or partial erasure is as simple as a wipe with the damp towel.

Any of these suggestions can help keep you from erasing holes in the grids in your manual!



EDUCATIONAL SOFTWARE  
For the Color Computer  
and TDP 100

# TOM MIX SOFTWARE

3424 College N.E.  
Grand Rapids, MI 49505  
(616) 364-4791



**SEARCH-A-WORD** This Program generates a word search puzzle to our specifications. You specify the size of the puzzle and the number of

words that it is to hide within the puzzle. 16K or 32K Ext. Basic.  
**TAPE \$17.95** **FLEX VERSION \$27.95**

**CLOCK** With the ever increasing use of digital clocks, more and more young people are unpracticed in the use of the "ANALOG" clocks. You remember those, the ones with the hands. This program will attempt to teach the relationship between the two types of clocks.

**REQUIRES 16K EXT. BASIC \$14.95**

**SPELLING TEST** is designed to give a standard oral spelling test using the audio track of the computer's tape recorder to dictate test words and sample sentences. Student responses are typed on the keyboard and checked by the computer. Results are displayed on the screen and (if connected) on a printer.

**REQUIRES 16K EXT. BASIC \$19.95**

**MATH DRILL** is a program designed to help children to practice addition, subtraction, multiplication, and division skills on the COLOR COMPUTER. It has several features that make its use particularly attractive.

- Up to 6 students may use the program at the same time.
- Answers for addition, subtraction and multiplication are entered from right to left, just as they are written on paper.
- Commas may be included in the answers.
- Partial products for the multiplication problems may be computed on the screen.
- Division answers that have a remainder are entered as a whole number followed by the letter "R" and the remainder.
- There are ten, user modifiable, skill levels.
- A "SMILEY FACE" is used for motivation and reward. Its size increases relative to the skill level.
- Skill levels automatically adjust to the student's ability.
- A timer measures the time used to answer each problem and the total time used for a series of problems.
- After a problem has been answered incorrectly the correct answer appears under (above in division) the incorrect answer.

**REQUIRES 16K EXT. BASIC \$19.95**

**WORD DRILL** is designed to give a multiple choice vocabulary quiz. Words and definitions are entered into the program from the keyboard or from a tape file. The computer displays a randomly chosen definition and eight word choices. The student must enter his response before a built in timer reaches zero.

**REQUIRES 16K EXT. BASIC \$19.95**

**EDUCATIONAL PACKAGE — SPELLING TEST —  
WORD DRILL — MATH DRILL — ESTIMATE —  
ALL FOR — \$69.95**



• ADD \$1.00 POSTAGE & HANDLING • TOP ROYALTIES PAID •  
MICHIGAN RESIDENTS ADD 4% SALES TAX • LOOKING FOR NEW SOFTWARE

**ESTIMATE** is a program designed to help children to practice estimating the answers to addition, subtraction, multiplication and division problems on the COLOR COMPUTER. It has many features that make its use particularly attractive:

- Up to 5 students may use the program at the same time.
- There are 5, user modifiable, skill levels.
- The acceptable percent error may be changed as a student's skill improves.
- A timer measures the number of seconds used to answer each problem and the total time used for a series of problems.
- If a problem has been answered incorrectly, the student is told the percent error and asked to try again.
- If a problem is answered incorrectly a second time, the student is told the correct answer and the range of acceptable answers is displayed.
- A report is given at the end of each set of problems that includes the number of problems done, the number of problems answered correctly on the first try and the average percent error.
- The (BREAK) key has been disabled so that a child will not inadvertently stop the program from running.

**16K EXT. BASIC \$19.95**

**TEACHERS' DATABASE** is a program designed to allow a teacher to keep a computerized file of information about his/her students. There are many features that make this program particularly attractive.

- Information on as many as 100 students (or more) may be in the computer at one time.
- Each student may have as many as 20 (or more) individual items of data in his/her record.
- The program will run from cassette or disk.
- Cassette and disk files are completely compatible.
- The program is menu driven.
- Records may be easily changed, deleted, combined or added.
- Information about students may be numerical or text.
- Records may be quickly alphabetized.
- Records may be sorted by various criteria.
- Records may be reordered (ranked) based on test scores or other data.
- Data displayed during a sort may be printed on a printer or saved on disk or cassette as a new file.
- A full statistical analysis of data may be done and sent to the printer.
- Student test scores may be weighted.

**32K EXT. BASIC TAPE \$39.95 DISC \$42.95**





- 4 IC2\*C3      Calculates the Cost of task I by multiplying the rate by the time of task I. (Uses the integer value)
- 6 IC2\*C5
- 8 IC2\*C7
- 10 IC2\*C9
- 12 IC2\*C11
- 14 IC2\*C13
- 16 IC2\*C15
- 17 IC3+C5+C7+ C9+C12+C13+C15      This is needed to calculate an interim total due to the limit on formula length.
- 18 IC2\*C17
- 20 IC2\*C19
- 22 IC2\*C21
- 24 IC2\*C23
- 26 IC2\*C25
- 28 IC2\*C27
- 29 IC17+C19+ C21+C23+C25+C27      This sums up the interim total and subsequent data.
- 30 IC2\*29
  
- 25 ISUMR10      Total wages adds all wages from the beginning of labor (Row 10) and gives the integer value.
- 26 IR25\*0.30      Calculates the fringe rate (30%)
- 27 IR25+26      Calculates total compensation
- 28 IR27\*0.40      Calculates overhead rate (40%)
- 29 IR27+28      Calculates total compensation
- 47 ISUMR33      Totals all direct charges from row 33 down
- 48 IR29+R47      Adds labor and direct for total prime cost
- 49 IR48\*0.15      Calculates G & A (15%)

- 50 IR48+49      Calculate total costs
- 51 IR50\*0.10      Calculates profit or fee (10%)
- 52 IR50+R51      Calculates total cost plus fixed fee

**Tips On Use**

After entering data delete unused columns and rows. The formula will be automatically adjusted. It reduces calculation time and makes a better looking printout. If you want the left hand stub printed on each page, simply delete the already printed columns after printing each page. Zeroes are entered under each time and # designation on this and the other budget shells. This serves two functions. The first is to assure the SUM command will work. A gap (no entry) causes this command to not function properly. The second function is to provide a pointer on where to enter data if the column heads are not visible.

**TRAVEL ESTIMATOR**

The travel estimator (See Figure 2) is a very simple yet handy shell. To use it I enter the trip plan using the ET "enter text" command—for example: "Boston-NY." Then using the EN "enter number" command I enter the number of trips, the estimated number of ground transportation and per diem required.

I wanted this to fit on one page so I substantially modified the standard column widths.

**Figure 2**

TRIP PLAN	AIR TRAVEL		GROUND TRANS		PERDIEM		TOTAL TRAVEL COST
	NO	RATE	NO	RATE	NO	RATE	
	1	0	1	0	1	0	
	1	0	1	0	1	0	
	1	0	1	0	1	0	
	1	0	1	0	1	0	
	1	0	1	0	1	0	
	1	0	1	0	1	0	
	1	0	1	0	1	0	
	1	0	1	0	1	0	
TOTAL	-	-	-	-	-	-	

**SETTING UP THE TRAVEL ESTIMATOR SHELL**

ENTER                      COMMENT

Set Column Widths

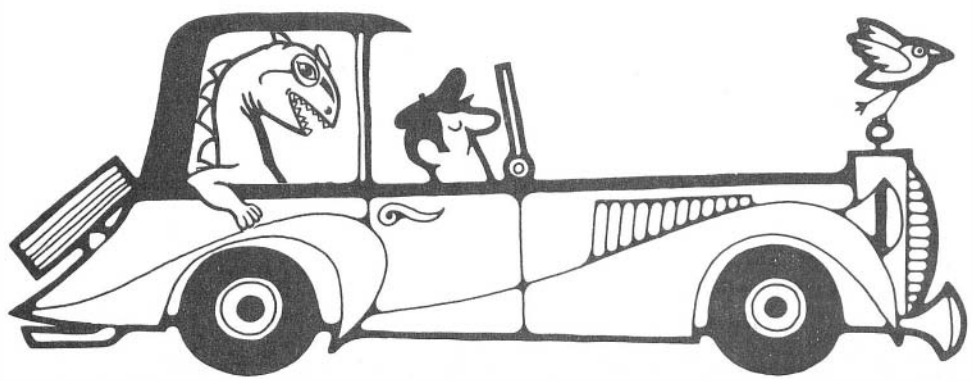



## Keytones Provides Auditory Feedback

By James Provost

*Keytones* is designed to produce a tone through the TV speaker every time a key is pressed.

The frequency of the tone may be changed using the *SOUND* command (e.g. *SOUND 225,1*), but the duration of the tone is set at one.

The user simply keys in the program, runs it and beeps away. This program is useful when punching in a set of numbers. The tone represents positive feedback for each keypress. This method eliminates the need to visually check the screen each time a number is entered. It thus becomes an added utility.

(At *Rainbow*, we like the effect created when you've typed in a line and then hit shift and left arrow key.)

My thanks to Kenneth G. Deahl's article in the February 1983 issue of *the Rainbow*. His reference to the RAM Hook sparked my inspiration.

### The listing:

```

1 REM KEYTONES
2 REM BY JAMES PROVOST
10 FOR X=1536 TO 1551
20 READ A:POKE X,A
30 NEXT
40 POKE 360,6:POKE 361,00
50 DATA 52, 86, 198, 1, 134, 4,
61, 253, 0, 141
60 DATA 189, 169, 86, 53, 86, 57

```

## Put Your Numbers In A Row

Mike Hall, of Hartland, WI, offers this programming quickie for anyone who needs to right justify numbers (that is, line them up properly for adding, subtracting, etc.). As written, it is for adding two numbers, but once the simple principle is learned, it can be readily adapted to whatever your individual needs may require. Just expand the program by providing for more number inputs (similar to lines 10 and 20) and move the celebrated "bottom line," created in line 120, farther down the screen by using, say, *PRINT@ 106* or *PRINT@ 138*, etc. (increments of 32—or, refer to a *PRINT@* worksheet).

### The listing:

```

1 'RIGHT JUSTIFIED NUMBERS
5 'USE NUMBERS LESS THAN 100000
10 CLS: INPUT "FIRST NUMBER";A
20 INPUT "SECOND NUMBER";B
30 CLS: C=A:X=10:GOSUB60
40 C=B:X=42:GOSUB60
50 FOR Z= 1 TO 999:NEXT:GOTO 10
60 P=X
70 IF C<10000 THEN P=X+1
80 IF C<1000 THEN P=X+2
90 IF C<100 THEN P=X+3
100 IF C<10 THEN P=X+4
110 PRINT@P,C:PRINT@41,"+";
120 PRINT@74,"-----"
130 RETURN

```

### TRS-80\* COLOR COMPUTER\*

- 16K Extended Basic, Menu-Driven, Well-Documented, Easily-Modified.
- For either cassette or diskette systems (Be sure to specify).
- Place an order of at least \$40 and get one extra of your choice free.
- Orders shipped on cassette - Add \$5 for shipment on diskette.

#### -FURST-



Data Element Dictionary driven File Update and Retrieval SysTem. Create and maintain files according to your specifications. Ideas for applications included. . . . . \$25

#### -MAILING LABELS-



Generate and maintain mailing label records. Selectively print desired quantities. Can keep several label files if desired. Designed for Printer VII, easily modified. \$20

#### -REPORT WRITER-



Used in conjunction with FURST to selectively format reports on your printer. Includes headings and total capabilities. . . . . \$15

#### -EXERCISE PLANNER-



Build and maintain complete exercise schedule for regular and/or weight programs. Display guides you through daily-calculated routines. Print complete schedule if desired. . . . . \$15

#### -DISK DIRECTORY PRINT-



For diskette users only. Get hard copy of disk directories on your printer for easy use and reference. Only \$5

Send check or money order to:



**LAND SYSTEMS**  
P.O. Box 232  
Bellbrook, Ohio 45305



\*TRS-80 and COLOR COMPUTER are Trademarks of Tandy Corp.



# Data Communications And Your Color Computer

By Harry Hardy

In today's world, more and more microprocessor owners have a need to go *on-line* to another computer, usually a large mainframe or some of the more powerful minis. Maybe they want to access a local bulletin board, or even do their shopping and banking at home. There are numerous *on-line* applications, therefore, it is beyond the scope of this article to cover them. What I hope to do is explain the function of the hardware and software required to get *on-line*.

---

*“More than likely, you will connect your modem to your Color Computer and a telephone. This method allows you to use what is called the switched network. In other words, after you are all connected, you use your telephone to dial the remote DTE just like a regular phone call.”*

---

*On-line* simply means establishing a direct connection between our terminal, i.e., Color Computer, and another terminal or computer.

Throughout this article, I shall refer to both our Color Computer and the remote device, whether it be another computer or a terminal, as Data Terminal Equipment (DTE).

I'm sure that if you have checked into the requirements of accessing some of the local bulletin boards you have found out that you need a *modem* and a special software package to run on your Color Computer. Maybe you already have these items. Whether or not that is the case, maybe you don't understand how modems work.

Let's take a look at the modem. Why do we need this? Up until the last few years, in order to get two or more pieces of data terminal equipment (DTE) to communicate with each other you had to use your local telephone company's switching equipment.

This equipment was designed to transmit voice or analog signals whether across the street or across country. These facilities work great for this; however, your DTE puts out what is known as a digital signal. This digital signal is incompatible with the existing telephone voice network.

That's where our modem comes in. Modem is an acronym for MOdulator, DEModulator. Different types of modems can do different things; however, since we are primarily interested in what it does for our Color Computer let's just say that its primary function is to take your Color Computer's digital signal, and convert it to an analog signal

for transmission over the telephone lines. At the other end, there is also a modem that takes the analog signal and converts it back to the digital signal for the remote DTE, the same as our modem will do for any replies from the remote DTE.

There are a couple of ways to connect your modem to the telephone network. More than likely, you will connect your modem to your Color Computer and a telephone. This method allows you to use what is called the switched network. In other words, after you are all connected, you use your telephone to dial the remote DTE just like a regular phone call. Once the remote DTE answers your call you hear a high pitched tone, then you may or may not, depending on your modem, simply hang up the telephone and proceed to log on to the remote system.

The other method is to have a “dedicated” telephone line between your system and the remote system. This kind of connection eliminates the requirement of a telephone to dial the remote system, but the hardware to use such a connection is expensive. I only mention using dedicated lines for those who are unfamiliar with data communications so you will know that there are other means to establish a direct connection between DTEs. No matter which method is used to connect these devices, what we now have established is what is known as a *data link*.

Once we have established our *data link* there is a certain line discipline or protocol that has to be followed in order to communicate with the remote DTE. This is where that special software package you have to buy comes in.

The type of transmission we will be doing between our Color Computer and the remote DTE is called *asynchronous* transmission. Asynchronous transmission is a type of protocol and is defined as “that type of transmission that sends one character at a time and lacks any continuous synchronous agreement between the DTEs.” Normally, this character consists of 8 to 11 bits.

Let's back up a minute for those newcomers who may not know what a *bit* is. A bit is the smallest unit of information within a computer system. This unit of information is an electrical charge that is either off (0 state) or on (1 state). A sequence of seven 0s and 1s are used to make up a character in the Color Computer. These seven bits are referred to as ASCII codes. For example, the ASCII code for the letter “A” within your computer is represented by the seven bits 1000001. Please note that not all computers use ASCII codes internally to represent characters; however, we will not get into those type of codes here.

Just a bit of history on ASCII. This code was first developed in 1963. The letters stand for “the American National Standard Code for Information Interchange,” also called ANSCII. The version modified in 1967 is called ASCII II and is the same code that is referred to as ASCII today.

Our Color Computer uses ASCII code to represent all of

its letters, numbers and special characters.

I heard that. Someone out there said, "Hey, I thought my computer stored things in hexadecimal or *Hex*." Let's take a moment to look at that. I don't want anyone to become confused between ASCII and Hex.

Hexadecimal is a numbering system with a base of 16 characters as opposed to 10 in the more familiar decimal system. The numbers 0-9 and the letters A-F are used. Eight bits, or one byte as it is called, makes up a hexadecimal character. Your Color Computer uses the Hex numbers for computations and addressing, etc.

Now suppose we *PEEKed* at a byte of memory and found the Hex character there was a 41. Remember I said each byte was made up of 8 bits, well, if you were to look at each bit, that Hex 41 would look like this: 01000001. That value, if converted to a decimal, would be 65. Now, suppose we wanted to print this byte of data, what do you think would come out on the printer? Give that person in Baltimore an A, for that's exactly what would print, the letter A. Now, suppose that location we *PEEKed* at had a Hex FF in it, and we tried to print it, what do you think would happen? That's right, nothing would print. Why? Well, that Hex FF, although it is a valid Hex character, is an invalid ASCII character. So, in essence, we can say that your computer stores ASCII characters as if they were Hex characters. (For a more in-depth look at Hex, see the article, "All You Wanted To Know About Hex," in this issue.)

But wait a minute, I thought that an ASCII character only had seven bits, what about that 0 in bit 8 (counting from right to left). Remember, I said that to transmit a single seven-bit ASCII character usually 8 to 11 bits would be sent out over the telephone line. Well, let's see if we can understand why.

I will use for our example the printer driver built into our Color Computer. This routine is similar to an output routine found in software packages required to communicate with a remote DTE. Depending on which version of Color BASIC you have, the number of bits sent to the printer is either 9 or 10. I will be using version 1.1 since it most resembles an asynchronous output driver. Our Color Computer will be using an asynchronous line discipline when we go on-line with a remote DTE. Well, this protocol uses framing bits called *start* and *stop* bits to surround each character. The *start* bit will precede the character and the *stop* bit will follow the character. Remember, asynchronous protocol is "that type of protocol that sends one character at a time, and lacks any continuous synchronous agreement between DTEs."

Without getting into the electronics of our modem, let's just say that these start and stop bits are used to help get the receive modem synchronized with the sending modem. This synchronization is required so that bits are not lost before we get them.

These bits are used by the protocol also as framing characters. How do they get there and what happens to them? Simply put, they are added by the sending end and removed by the receiving end. Let's see why. Look at our version 1.1 printer driver again. This driver sends eight data bits preceded by one start bit and followed by one stop bit. The start bit is a 0 bit while the stop bit is a 1. Imagine now that our printer is a remote DTE. When the remote DTE sees the 0 bit or start bit it knows that the next eight bits represent a character that it has to act upon. It will then assemble these eight bits and, in our case, print it. The stop bit will indicate to our remote DTE the end of the character and start monitoring the line for another start bit. (Although

our driver is sending only one stop bit, two stop bits may be more common. In either case, each end will have to be aware of the actual number.)

You may be wondering why even send a stop bit. Why can't we just start looking for another start bit, or even better yet just assemble each group of eight bits for a character? Well, we just can't arbitrarily assemble bits and expect to get meaningful data. Suppose our DTE just sent the data bits. During this transmission, let's also suppose, for whatever reason, that one of these bits gets destroyed. We would now start assembling bits from two characters that could cause some strange results.

Now you know what those extra bits are, and what their purposes are; well, almost all of them. Remember, I said our driver sends eight data bits, not seven. We know that seven bits make up an ASCII character. What is that extra bit for?

That eighth bit serves another purpose in asynchronous protocol. That purpose is a parity bit. This parity bit is a method of error detection. There are three terms used for this parity checking; *even parity*, *odd parity*, and *no parity*. The method chosen is up to the designer of the DTE, therefore, our communications software must know which method is used at the remote end. Let's take a look at these methods.

First, even parity. It has been my experience that this method is the most common one used. (I know as soon as you read this the first terminal you will see will use one of the other two; Murphy's law is sure to get me.)

What your software does using the even parity method is this: it counts the seven data bits of the ASCII character. If the total number of 1 bits is an odd number it sets the eighth bit to a 1, thus ensuring an even number of 1 bits. If that total is even, it leaves the eighth bit a 0. Look at our letter A again.

## IMPORTANT NOTICE ABOUT SUBSCRIPTIONS

The "May" issue of *the Rainbow* will carry a cover date of June this year. As far as the cover dates are concerned, there will be no May issue.

The reason for this is simply a cosmetic one. We would prefer, and think that you would prefer, to get a particular issue of *the Rainbow* in advance of the month which appears on the cover rather than in the middle of the month which appears on the cover.

What this means is that your June issue will arrive before the first of June, and that our big July Anniversary issue will be in your hands before the first of July.

There will be no "break" in magazines and absolutely no change in the number of issues you will receive. This will be obvious from next month's (not this month's) subscription label—which will show an expiration date one month later than the date shown this month.

You will still get 12 issues of *the Rainbow* with a year's subscription. All the change means is that your subscription will "expire" one month later than usual. And, you will still get a copy of *the Rainbow* every single month at about the same time. The only difference is that it will appear that you get your subscription copy "earlier" than before.

So, you will not be "missing" an issue in May. But the issue which arrives in May will carry a June cover date. That's actually the only difference—a cosmetic one which will make it appear that you get your *Rainbow* earlier than before.

The bits for an A are 1000001. If we add these up, you can see that we have an even number of 1 bits, therefore, that eighth bit would remain a 0; however, the letter C consists of these seven bits, 1000011. Since these bits will add up to an odd number of 1 bits, we would set that eighth bit to 1 giving us an even number of 1 bits.

Odd parity works just the opposite. If the total number of 1 bits is odd, then bit 8 is left 0. If the total is even, the eighth bit is set to a 1.

The last one, no parity, means just that. The eighth bit is left as is, 0. This is the method our 1.1 printer driver uses. After all, it is unlikely, given the short distance a bit has to travel from your printer port to the printer, that it would ever get destroyed.

What about the receiving station? It does basically the same thing. It counts the seven data bits and, according to which method is being used, checks the eighth bit accordingly. If it's not what it should be, then we know that there was some type of transmission error. As with our printer driver, chances are the communications software you buy will use the no parity method of transmission. You will see why in a moment. The only way you will know if there was an error is by one of the oldest methods used. The receiving end simply echoes the character it received back to the sending end—you. If the character displayed corresponds to what you entered, all is okay; if not, you know immediately that something went wrong. You can probably see the problems with this method. You don't know if the bad character was due to an error at your end at transmission time, or at the other end, when the character was echoed back.

While parity checking adds to the ability of our system to detect errors, it also has its flaws. Consider, if you will, that some type of error caused two bits to change value, i.e., 01000001 was changed to 01000010, we still have a valid parity check and even a valid character, but it is not the character sent. That 01000001 is the letter A, which is what was sent; however, the 01000010 is the letter B.

What to do about these transmission errors? Well, all the software that I'm familiar with, at least for the Color Computer, doesn't do anything with these types of errors except try to display them on your screen whether they are responses from the remote DTE or your transmission being echoed back. The reason is simple. The more sophisticated error detection methods, especially error recovery, are costly to implement and, for the most part—I realize there may be exceptions—are not implemented in asynchronous protocols for the smaller micros.

But, really, do we need that type of sophistication when all we want to do is access our local bulletin boards? I don't think so. Besides, although it may sound like transmission errors are a real big problem for you, they probably are not. If you are having some problems, chances are it could be in the telephone connection you have. After all, using the switched network for data transmission is not the best method, but, in our case, we probably would rather sacrifice quality for cost. If errors are a continuing problem for you, it may be in your modem. Maybe you should have it checked.

Next month, I will cover in greater detail some of the error detection and recovery methods that can be used, and introduce you to some new terms describing three modes of data transmission.

I hope you now have a better understanding of what that modem and the special software package you must buy, or have bought, does for you and your Color Computer. ☺

Software Review . . .

## A 'Fine' Weather Program Is *Weather Watch*

Do you want to track weather trends in your area, or study how the temperature affects energy use in your house? *Weather Watch* can help. It won't predict the weather, or tell you when to wear your galoshes, but it does provide a convenient file of weather data.

*Weather Watch* is a package of three programs. The first, *Daily Data Entry*, allows you to enter each day's high and low temperatures, and amount of precipitation, and store it on tape. The third program, *Daily Entry View*, allows you to review one day's data previously stored.

The second program, *Monthly Summary*, is the heart of the package. It reads a month's worth of data from tape, and summarizes it in every imaginable way. It repeats the data you entered, and gives the daily average, range, and number of heating and cooling degree days. Heating degree days are the number of degrees the daily average is below 65 degrees. Cooling degree days use degrees above 65. These provide a good indication of how much you will have to heat or cool your house. The program then summarizes monthly totals, maximums and minimums. The report is nicely formatted, in tabular form, and it is easy to find the data you want. You may either display the monthly report on your screen, or send it to your printer.

While the program performs all the functions described in the manual, it has some flaws. The most serious is with data formats. In programs 1 and 3, dates must be typed in exactly this format: JUL/03/82. If you type JUL/3/82 instead, the program will be unable to find your data later. While a regular user would quickly get used to the required format, a single error could ruin an entire month's data tape. There's really no excuse for not adding the few lines of code necessary to verify the format.

In addition to this design flaw, there's an actual bug in the second program. If you store two months' data on one tape, the program will read the first month's data, regardless of which you request. The distributors have assured me this bug is being corrected.

If you study the weather seriously, then you might need a more sophisticated analysis than this package provides. But if you want to record and summarize daily temperature and precipitation data and the other functions provided here, this program is "fine."

(Petrocci FreeLance Associates, 651 N. Houghton Rd., Tucson, AZ 85748, \$24.95)

—David Finkel

\$14.95 M. Character Set for LPVII - Real Descenders  
-transparent to user - Specify 16K or 32K  
-ext: Varying Styles Available

\$9.95 MLDISK - Prints M. L. prog.start, stop, transfer  
address from disk, Extended Basic req'd

\$14.95 Instrument Flight Simulator -high perf jet,  
easy to use, NOT A GAME. Extended Basic req'd  
Also, for PC-1 computer \$9.95

WE HAVE COLORPEDE by Intracolor!

KRT Software (813)-321-2840  
P.O. Box 41395 . St. Petersburg, FL 33743 .



## Super-Pro Keyboard Is An Excellent Hardware Offering

The newest entry in the replacement keyboard sweepstakes is a fine piece of hardware from Mark Data Products called the *Super-Pro*. It is aptly named—it is super and it is professional, too.

We confess that we always liked the CoCo keyboard. Although the numbers of people who said something less than complementary about the “flat” and “shallow” CoCo keyboard were and are many in number, it always appealed to us. In fact, we were able to do some of the fastest typing we ever did with the CoCo keyboard.

But in all honesty, we like the *Super-Pro* just as well. And, we are certain, touch-typists will think it a vast improvement. Here at *the Rainbow*, those who do touch-type like it a whole lot better.

For our part, the feel is excellent and the keys have the proper amount of “give” that make you feel like you are getting some feedback from what you put in—but not too much. The keytops are gently sculptured and the letters are large size. Yes, throughly professional.

The *Super-Pro* appears to be very much like (if not exactly like) the Model I keyboard—but there is no “bounce.” We tried to make it bounce, but were not successful. The keys are all the same color, which may or may not be an advantage for you.

What *is* an advantage is that the keyboard layout is exactly the same as that of the CoCo. So, aside from a better feel and more dressed up appearance, you do not have to “relearn” the keyboard. A decided bonus.

The *Super-Pro* is advertised as a kit, and, in the most strict sense of the word, that’s what it is. There is a little more to the installation than just plugging it in, but not a great deal more.

You install *Super-Pro* by opening the CoCo case, unplugging the old keyboard connector, and positioning the *Super-Pro* into the empty space. The keyboard has four little adhesive pads which can be used to stick it firmly to the bottom of the case.

The worst part of this whole process was dealing with a plastic post that sticks up in the middle of the bottom of the CoCo’s case. The post has to be partly cut off—for which you need some sharp cutters. The *Super-Pro* instructions say that the post is not needed, even if you decide to put the old keyboard back in. We were able to confirm that.

A couple of plastic washers are also supplied to even up a dressing panel which “fills in” the space between the CoCo case and the *Super-Pro* when you put your computer back together. Dealing with this dressing panel looked like it was going to be complicated, but was not.

All in all, installation took about 15 minutes. And that included the time it took to cut off the top of the little post. No big deal, not even for someone who is not especially handy. Having the dressing panel provided a bonus in that it made it easier to plug the *Super-Pro* into the computer.

Some Color Computers—those built after about October, 1982—and all TDP-100’s require a special adapter to mate the keyboard with the computer. This is an easy procedure to follow, however, and would add about a minute to the installation time.

The *Super-Pro* has been with us for several weeks now. Our touch-typists like it a great deal and those of us who hunt and peck also find it to be an improvement over the CoCo keyboard.

In sum, *Super-Pro* is an excellent and high quality keyboard that answers a real need voiced by many CoCo owners. If you are searching for a replacement keyboard, it is an excellent buy.

(Mark Data Products, 24001 Alicia Parkway, No. 226, Mission Viejo, CA 92691, \$69.95; adapter, if needed, \$4.98 additional)

—Lawrence C. Falk

### PoEDIT License...

## BASIC Shakespeare

By H. Allen Curtis

Oh what a rogue AND peasant SAVE am I.  
All the world’s a SCREEN.  
The PLAYS the thing.  
TO GO OR NOT TO GO.  
My kingDIM FOR a MOTOR.  
Ah, that’s the RUN.  
SomeSTRINGS\$ rotten in REMark.  
SOUND AND fury, SGNifying nothing.  
Is that a JOYSTK which I see beFORE me?  
AUDIO, AUDIO, whereFORE art thou, AUDIO?  
RESET damn spot.  
DIMension is the better part of VAL OR.  
All’s DEL that ENDs DEL.  
Good-night, sweet PRINTs.

## CANADIANS! GET YOUR SOFTWARE HERE IN CANADA

No Hassle, No Duty and  
No Converting the Dollar

<i>Computerware</i>	
PAC ATTACK II	\$29.95
DOODLE BUG	\$29.95
RAIL RUNNER	\$26.95
SPACE AMBUSH	\$26.95
EL DIABLERO	\$24.95
<i>Tom Mix Software</i>	
DONKEY KING	\$29.95
KATERPILLAR ATTACK	\$29.95
WAR KINGS	\$24.95
<i>Spectral Associates</i>	
GALAX ATTAX	\$26.95
SPACE WAR	\$26.95
GHOST GOBBLER	\$26.95

Order Now or write for our  
complete software list.  
**TABBY ENTERPRISES**

Box 1353 R.R. 1  
Yarmouth, Nova Scotia  
B5A 4A5  
(902) 649-2965

# Paging Down Memory Lane: It May Look Like Garbage, But It's Gold

By Richard Krankoski

This program gives you a look at memory in real time. Its original purpose was to look for command words in a machine language Adventure game, but it became a visual aid tool used with some CoCo tutorials and "how-it-works" articles. By selecting blocks of memory or "pages," you can see the buffer areas in low RAM as they are accessed and changed, the operation of the stack, the structure of the program itself, and the execution or results of many BASIC instructions. The program can also be used to examine text or graphics of other programs.

The program works by controlling the video screen display offset registers and the display mode registers in the SAM and VDG hardware. Lines 160 through 210 control the display offset in increments of 512 bytes. Lines 310 through 360 control the display mode, either text or one of the PMODEs in color set 1.

---

*"In the text mode, the screen displays the contents of 512 consecutive bytes of memory in the form of 16 lines by 32 characters per line."*

---

The following control keys are used:

UP ARROW/DOWN ARROW—increments or decrements the display offset by 512 bytes.

"T"—selects the TEXT mode.

"O" through "4"—select the graphics PMODE in color set 1.

"N"—displays a message to let you specify a particular page number.

"#"—displays the message screen that tells what part of memory is being displayed.

"E"—executes any instructions that you add between lines 400 and 500.

Note that we are defining a page as being 512 consecutive bytes of memory. Page 0 consists of memory locations 0 through 511. Page 1 consists of memory locations 512 through 1023. We are referencing the page size to the text mode, so don't confuse the pages with those mentioned in articles about graphics. In the text mode, the screen displays the contents of 512 consecutive bytes of memory in the form of 16 lines by 32 characters per line.

What you will see displayed in the text mode is a screen

code equivalent of the value stored in a memory location. This is not always the same as the ASCII character. For example, a byte value of zero will be displayed as an inverse video @ sign. You can find a list of the differences on the Nanos System reference card for the Color Computer. To see the difference, run the short program in Listing 1.

The reference card is handy for determining the value of an address while looking at the screen. Be careful of getting a byte value in the buffer areas by *PEEKing* the address, because you are looking at the memory value in real time. If you change the running conditions, you may change that address's value.

When a graphics mode is selected, the amount of memory displayed increases to 1536 bytes for PMODE 0, 3072 bytes for PMODES 1 and 2, and 6144 bytes for PMODES 3 and 4. However, the memory page reference will still refer to the text screen page size of 512 bytes, and the arrow keys will still change the offset by 512 bytes. Therefore, in a graphics mode, the message screen page number will refer to the first 512 bytes of memory being displayed and not to a graphics page number.

Listing 1:  
SCREEN CODE VS ASCII CODE

```

1 CLS
2 FOR V=0 TO 255
3 PRINT @ 32, V
4 POKE 1066,V
5 PRINT @ 46, CHR$(V)
6 FOR T=1 TO 300: NEXT T
7 NEXT V

```

If you want to follow along on a short guided tour through the program and through RAM it will be helpful to start from the same point. Before loading in the program, turn your computer off and then back on so that we have the same initial conditions and a "clean" memory. Also, if you have more than 16K of RAM, do a *CLEAR 200, &H3FFF* in the direct mode. This will bring the stack and *CLEARed* area to the top of the 16K space. Certain hardware configurations such as my piggyback RAMS on a REV D board will not display an offset above address \$3FFF.

Load and *RUN* the program. The prompt will ask for a page number from 0 to 31. (Remember, my display limit is 16K which is 32 pages.) *ENTER*0. The next screen tells you what part of memory will be displayed. Press *ENTER*. You now see the first 512 bytes of RAM and can see that there is a lot of activity. CoCo is doing a lot more than checking for a keypress in the *PAGER* program.

If you loaded in from tape you will see the program name near the bottom-right of the screen. Trying hitting some

keys other than control keys and you will find a keyboard buffer. To find the two byte timer, press the shift and "@" keys at the same time. Everything else comes to a stop. You may want to get your copy of *Rainbow*, August 1982, which has a list and description of some of the addresses in this part of memory. It shows the timer addresses as (HEX) 112 and 113. Press one of the keys repeatedly and watch addresses (HEX) 24 and 26 (decimal 36 and 38) near the start of the second line. These locations appear to be some kind of keystroke counters.

If you hit the "E" key you will execute the *SOUND* instruction in line 410. Before moving on, *BREAK* the program and add line 420.

```
420 Q=JOYSTK(0):GOTO420
```

*RUN* and go back to page 0, then hit the "E" key. By moving the joysticks you will find the four addresses that store the joystick pot values. To go on, you will have to *BREAK* and delete line 420, then *RUN*.

Go back to page 0, then hit the up arrow. This puts you on page 1, a quieter workspace with a lot of bytes displaying the inverse video @ sign which is a value of zero. In the center of this area is a large I/O buffer. You will probably see a part of the program or a part of your keyboard entries here. A few addresses have non-zero values that change under certain conditions but I haven't found a source that identifies them (hex 729-732 and hex 981-991).

Hit the up arrow again—just one time. It looks like a normal text screen. Everything is there except the cursor. That's because we moved up to page 2 which is the memory

area normally used to display text, except that we are not in a normal text mode. Therefore, no cursor. We have changed the display offset registers but have not executed a text screen function such as *INPUTA\$*. What you see is whatever was last displayed in a normal BASIC text mode which puts its data into memory locations hex 400 to hex 5FF. If you have followed along faithfully the top of the screen should say, "PAGE 0 OF TEXT MODE" along with page zero's address data. Now, hit the "#" key and the proper data is put on the screen along with the cursor. Since you are displaying page 2, when you hit *ENTER* there will be no change except that the cursor will go away because we are at the *INKEY\$* part of our program.

If you have seen a machine language program that puts a display on the screen while it continues to load, you can now see how it is accomplished. The program begins loading somewhere below page two and the values loaded into addresses hex 400 to 5FF are those required to put a *SET/RESET* graphics block picture together.

Hit the up arrow again. You will see bands of @ signs and bands of orange. A solid orange block results from a byte value of 255. This data is put into memory during the start-up routine when the computer is turned on. Every 128 bytes you will see one or two bytes with values other than 0 or 255. I don't know what their significance is. They are different values from one power up to another.

Now is as good a time as any to introduce the graphics modes, so try the "0" through "4" keys. Hit the 4 key to get into *PMODE 4*, then *SHIFT #*. The screen now tells you what part of memory is being displayed. It should say

# WORD PROCESSOR for only \$9.95! What?

Yes! That's right, because we want to create some excitement with an introductory offer you can't pass up — a professional quality full screen oriented word processor that would be a bargain at \$50. It's a good one too. Take a look at what you get.

**WORDMASTER's FULL SCREEN-ORIENTED EDITOR** allows you to move the cursor anywhere in your text using the up, down, right and left arrows. Do this one character at a time or by line or page. Insert, delete or replace text at the cursor watching your changes as you make them. Delete or move blocks of text from one place to another. Merge in text from other files.

**AUTOMATIC CARRIAGE RETURN** after last complete word on each line; with this and **AUTOMATIC PAGE FEED** you don't have to worry about where a line or page ends — just type!

**WORDMASTER** runs on a **16K, 32K, or 64K COLOR COMPUTER**, taking advantage of all available memory. Use it with **DISK OR CASSETTE** based systems. **EXTENDED BASIC IS NOT REQUIRED.**

**EASY TO UNDERSTAND MANUAL** has you comfortably using **WORDMASTER** in minutes. It is a **USER-FRIENDLY MENU-DRIVEN SYSTEM** with single letter commands. Check any command without having to refer to the manual with the **HELP SCREEN.**

**10 PROGRAMMABLE FUNCTION KEYS** allow easy insertion of frequently used words or phrases.

**WORKS WITH ANY PRINTER.** Take full advantage of your printer's special functions such as variable character size and emphasized characters with **EASY EMBEDDING OF PRINTER CONTROL CODES.**

**GLOBAL SEARCH** function lets you quickly locate specific strings for replacement or deletion.

Customize form letters or standard text with **WORDMASTER's EMBEDDED PAUSE** feature. Just "fill in the blanks" when your printer pauses for a personalized appearance.

**LIMITED MULTI-TASKING** feature lets you print one file while editing another.

In addition to regular text you can use **WORDMASTER** to **CREATE BASIC PROGRAMS** with the convenience of full-screen editing.

**OTHER FEATURES** include easy setting of left, right, top and bottom margin, printer line width, and lines per page. Also auto repeat keys, auto line centering, auto page numbering and choice of display color formats.

And, perhaps one of the best features, but one that won't last long, is **WORDMASTER's SUPER LOW INTRODUCTORY PRICE OF \$9.95.** At this price you can't go wrong. Buy it today!

**TO ORDER** send \$9.95 for cassette version or \$14.95 for disk version plus \$2.50 shipping (Calif. residents add 6% sales tax) to: **PYRAMID DISTRIBUTORS, 527 HILL ST., SANTA MONICA, CA 90405 (213) 399-2222.**

# WORDMASTER \$14.95 Disk \$9.95 Cassette



addresses 1536 through 7679 (hex 600 through IDFF). This space comprises the first four graphics pages which are reserved as part of the start up routine. For a quick demonstration, *BREAK* the program and add line 450.

450 PMODE 3,1:PCLS

Now, *RUN*, select page 3, select PMODE 3, then hit the "E" key. Line 450 did a PCLS on the first four graphics pages. All of the bytes have been set to zero. The "T" key will present you with a screen full of inverse @ signs.

*BREAK* again and add line 460 and line 470.

460 CIRCLE (100,100),30,7

470 PAINT (100,100),6,7

*RUN*, get page 3, PMODE 3, and hit "E" again. Try the other modes and the arrow keys and repeat the "E" key. This should help you to understand some of the graphics concepts.

While paging up and down you probably saw a band of hash rise from the bottom of the screen. Select PMODE 3 or 4 and page up the hash until it is at the top of the screen, then hit the "T" key. You have found the start of the program as it resides in memory. The "#" key will show you that it starts at address 7680, page 15.

Increment up a couple of pages to see the rest of the program and the variable storage area. Beyond that are more bands of zeros and 255s except for page 31 which we will get to shortly. For now, let's see how you get more memory from the PCLEAR command. *BREAK* the program and in the direct mode type in PMODE 0 : PCLEAR 1 then *ENTER*. *RUN* and select page 6 in the text mode. You

---

*"The space above the program hash is the area commonly known as the PCLEAR 0 area for which there is no valid BASIC command. Right now it is the only place that you can put high resolution graphics."*

---

now see that the program has been moved lower in memory starting at address hex COO. To get a better perspective select PMODE 4. You can see that the program data was also left in its original location, but it is no longer serving any purpose because the system's pointers have been reset to point to the new program area. The address space of the original program can be used for other purposes. More memory is available for program lines and variables, but less is available for graphics. You can see that our picture got clobbered.

Use the "N" key to select page 3 while staying in PMODE 4. The space above the program hash is the area commonly known as the PCLEAR 0 area for which there is no valid BASIC command. Right now it is the only place that you can put high resolution graphics. Hit the "E" key. The FC error appeared because we are now trying to draw in the wrong place in the wrong mode. The area is now reserved for programs and variables. Change line 450 to read PMODE

0,1:PCLS and then *RUN*, select page 3, PMODE 4, and then hit "E." Did you get two circles? Hit the "0" key and maybe they will go away.

By the way, as you may have seen elsewhere, you can use that last part of memory for program memory by entering POKE 25,6:NEW in the direct mode *before* loading or writing a program.

The last stop on this tour is the stack area and the CLEAR command. Go to the text mode and select page 31 ("N"...etc.). If you have 16K or you executed the *CLEAR* 200,&H3FFF instruction at the start of this article, you are now looking at the stack area in action. The microprocessor uses this area for temporary storage of its register's data. Some of what is going on here is related to the activity you see on page 0.

At the bottom of the screen is the area that was reserved by the *CLEAR* command. *BREAK* the program and type in *CLEAR* 20 in the direct mode. *RUN* and get back to page 31. The space reserved for strings has been reduced, the stack has moved up in memory, and program memory space has increased. If you have more than 16K RAM, the space above page 31 has been reserved for machine language programs by the *CLEAR* XXX,&H3FFF command.

Note the words "RANGE IN" at the bottom of the screen. Now, *BREAK*, type in *CLEAR* 10, then *RUN*, select any page, and after the error message LIST line 110 and you will see the string for which there was not enough room.

For our last trick we can demonstrate how an improperly used *GOSUB* can bomb a program. *BREAK* and *CLEAR* 200. Add the following lines:

480 GOSUB 600

600 GOTO 480

*RUN*, select page 3, select PMODE 4, then hit the "E" key. Wait a few seconds...Here comes the stack. The stack kept building because each execution of the *GOSUB* command added more "temporary" data to it and there was no execution of a RETURN command to unstack any of the data. No harm was done to this particular program, but that is probably an exception. *RUN* and page through memory above the program area. You will see the same data stored over and over for each time the *GOSUB* was executed.

The rest of the snooping is up to you. Examining other programs may be tricky. If a program self-starts, try moving the stack down. Load and run the program you want to examine, then load in *PAGER*. You may load on top of a part you wanted to see. If so, use the *PCLEAR* command to control where *PAGER* will load in.

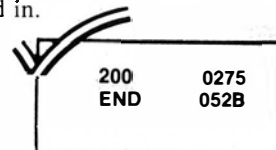

The listing:

```

10 REM START OF PROGRAM AREA
15 G$="9"
20 CLS:PRINT"ENTER PAGE NUMBER 0
   TO 31"
30 INPUT PG
40 CLS
50 ST=PG*512:EN=ST+511
60 IFG$="0"THEN EN=ST+&H5FF:PRINT@160,"PMODE0 PAGE LENGTH=1535 B
   YTES":PRINT:PRINT
70 IFG$="1" OR G$="2" THEN EN=ST

```

# MONKEY KONG!

By Ken  
Kalish

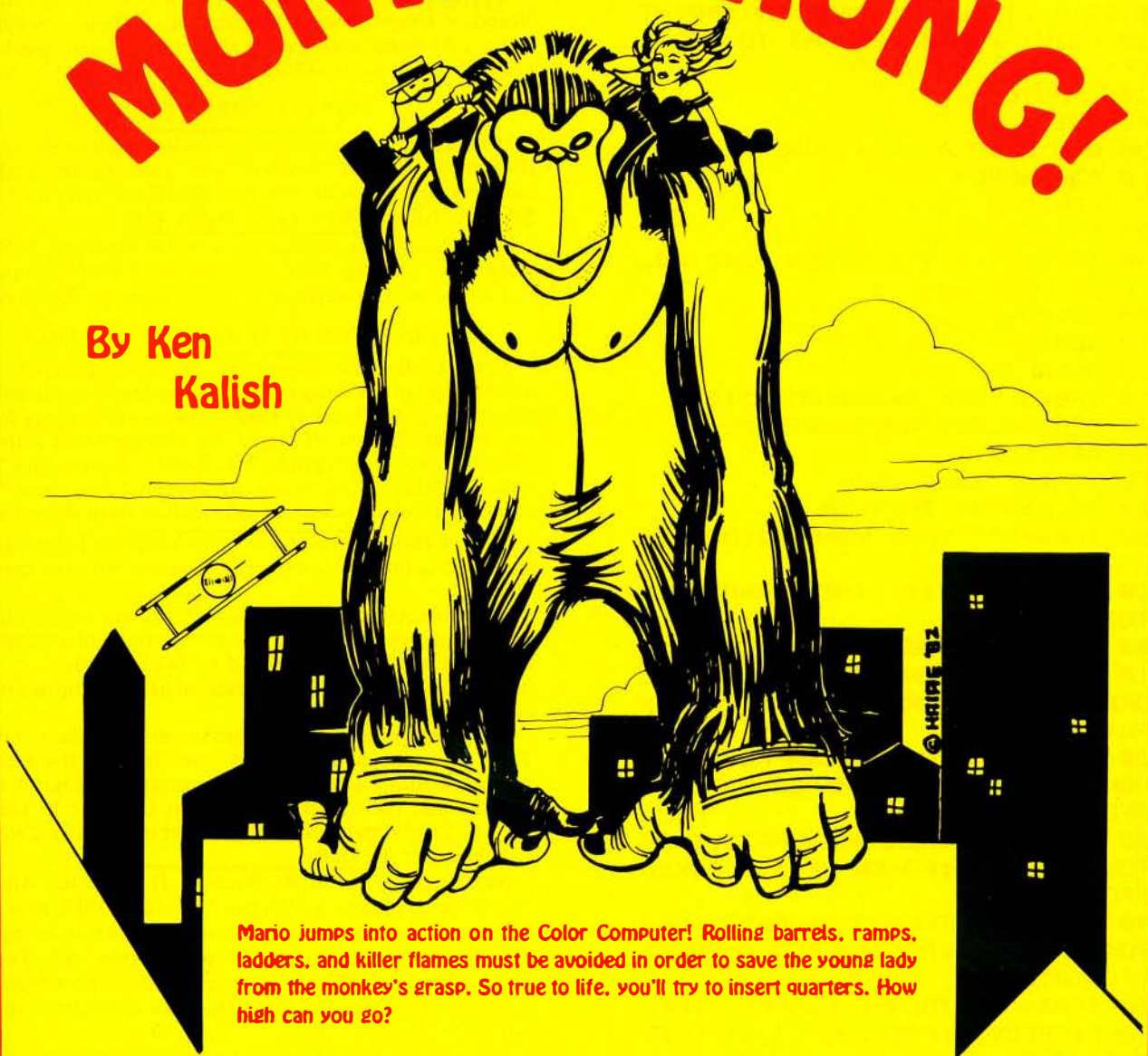

Mario jumps into action on the Color Computer! Rolling barrels, ramps, ladders, and killer flames must be avoided in order to save the young lady from the monkey's grasp. So true to life, you'll try to insert quarters. How high can you go?



**MONKEY KONG** Color Computer 16K cassette . . . . . \$24.95  
Please add \$2.00 for shipping and handling



**Med Systems Software • P.O. Box 3558 • Chapel Hill, NC 27514**  
**TO ORDER, CALL: 1-800-334-5470**

```

+&HBFF:PRINT@160,"PMODES 1&2 PAG
E LENGTH=3072 BYTES":PRINT:PRINT
80 IFG$="3" OR G$="4" THEN EN=ST
+&H17FF:PRINT@160,"PMODES 3&4 PA
GE LENGTH=6144 BYTES"
90 PRINT" PAGE "PG" OF TEXT M
ODE":PRINT
100 PRINT"ADRESS RANGE="ST"..TO.
."EN:PRINT
110 PRINT"RANGE IN HEX= "+"$HE
X$(ST)"..TO.."+"$HEX$(EN):PRINT
120 PRINT"PRESS <ENTER> TO SEE P
AGE"
130 INPUTE$
140 PRINT
150 REM DISPLAY NEW PAGE
160 AD=&HFFC7
170 FOR X=0 TO 6
180 BT=PG AND 2^X
190 IF BT=INT(2^X) THEN POKE AD,
0 ELSE POKE AD-1,0
200 AD=AD+2
210 NEXT
220 G=VAL(G$)
230 IFG<5 THEN A$=G$:GOTO310
240 REM SELECT ANOTHER PAGE
250 A$=INKEY$
260 IFA$="" THEN 250
270 IF A$="N" THEN 20
280 IFA$="^" THEN PG=PG+1:GOTO16
0
290 IFA$=CHR$(10) THEN PG=PG-1:G
OTO160
300 IFA$="#" THEN 40
310 IFA$="0" THEN POKE&HFF22,&HB0:
POKE&HFFC1,0:POKE&HFFC3,0:POKE&H
FFC4,0:G$=A$
320 IFA$="1" THEN POKE&HFF22,&HC0
:POKE&HFFC0,0:POKE&HFFC2,0:POKE&
HFFC5,0:G$=A$
330 IFA$="2" THEN POKE&HFF22,&HD0
:POKE&HFFC1,0:POKE&HFFC5,0:POKE&
HFFC2,0:G$=A$
340 IFA$="3" THEN POKE&HFF22,&HE0
:POKE&HFFC0,0:POKE&HFFC3,0:POKE&
HFFC5,0:G$=A$
350 IFA$="4" THEN POKE&HFF22,&HF0
:POKE&HFFC0,0:POKE&HFFC3,0:POKE&
HFFC5,0:G$=A$
360 IFA$="T" THEN POKE&HFF22,0:PO
KE&HFFC0,0:POKE&HFFC2,0:POKE&HFF
C4,0:G$="9"
370 IFA$<>"E" THEN 250
400 REM 400 LINE AREA FOR INSER
TING EXPERIMENTS
410 SOUND 2,2
500 GOTO250
999 REM END OF PROGRAM AREA...VA
RIABLE AREA FOLLOWS

```



## CORRECTIONS

In the listing that follows "Hang Around, You'll Enjoy This" (February 1983), there was an unexpected hang-up. Line 800 had a glitch, or maybe a gremlin, which caused it to throw in some dashes and run into line 810. Correctly, these lines should read:

```

800 FOR I=1 TO KNT:PRINT WRD$(I)
;:NEXT I
810 PRINT: PRINT" -
RIGHT ? (Y/N)"

```

A program line was omitted from a short listing used in "Random Often Needs A Helping Hand" (February 1983). In the right-hand column on page 14, there should have been a line 55 which reads as follows:

```
55 IF L=0 THEN STOP
```

In the article "Spectaculator Gives Spectacular Statistics" (February 1983), the "less than" and "greater than" symbols were left out of line 30. This line should correctly read:

```
30 IF LEN(A$)<>16 THEN 20
```

In the listing which follows "Power (of Attorney) At Your Fingertips" (March 1983), the command *PRINT* was left out of line 60. Correctly, the line (on page 56) should read:

```
60 PRINT "FOR GENERAL APPLICATION"
```

Several folks have offered fixes for what appeared to be an oversight in our *Dungeon Adventure* graphics Adventure winner program (January 1983). It turns out Gregory Ricketts had us covered all along; the oversight was with *the Rainbow*, not the program. Mr. Ricketts reports that "hitting the 'Q' key will allow you to exit the fight sequence." We managed to omit that bit of information from the story.

In our February issue, Lane Lester's *Income Tax* program (page 18) contained some inconsistencies with the current form.

The corrected version of *Income Tax* not only matches the current forms but also has some small enhancements, several of which were suggested by Justin Snyder.

For a free print-out of the corrected listing, drop us a note, or call.

While this program is included in our April *Rainbow On Tape*, you may wish to order directly from the author. Anyone wanting a taped copy of this revised program may send \$5 and their name and address to: Lane P. Lester, Ph.D., Department of Biology, Liberty Baptist College, Lynchburg, VA 24506.

As written in Burton R. Witham, Jr.'s article, "Among The 'Super' This One's a 'Duper'," (January 1983, page 80) the program listing will only allow 10 contacts to be logged reports Melvin Nelson (W8UNB), Phoenix, AZ. This is because the CLEAR 900 statement in line 200 also clears the array defined in line 100. Also, there is a redundancy in line 310.

To correct these problems, add a line 90 and alter lines 200 and 310 as follows:

```

90 CLEAR 900
200 SOUND230,2:CLS:G=136:H=137:N
=0
310 CLS:PRINT@19,"LOG#:";:PRINTU
SING"#####.";X:PRINT@64,"CALL-"
;C$(X):PRINT@78,"TIME-":POKEH,83
:LINEINPUTT$(X):PRINT@96,"FREQ-"
:POKEH,101:LINEINPUTF$(X):PRINT@
107,"NOTES-":POKEH,113:LINEINPUT
N$(X):IF X>1 THEN GOTO330

```



BUY ANY  
ONE ITEM  
TAKE A

**10%**  
DISCOUNT

# ARCADE GAMES

BUY TWO OR  
MORE ITEMS  
TAKE A

**15%**  
DISCOUNT

## SPECTRAL ASSOCIATES

**SPACE WAR**-Fast action. You must break through enemy defenses of death star to win. Watch out for black holes. 16k & joystick required

CASSETTE ..... \$21.95

**BATTLE FLEET**-Traditional favorite. As Admiral-in-Command, you declare war against opponent or computer. Challenges your naval tactics. Extended basic required.

CASSETTE ..... \$14.95

**SPACE TRADERS**-Can you become the Horatio Alger of outer space? Become a millionaire if you make the right moves for 2 to 4 players. Extended Basic required.

CASSETTE ..... \$14.95

**ROBOT BATTLE**-Guide your human through an ever changing maze and never ending attacks of robot hordes. A berserk type game. 16k joysticks required.

CASSETTE ..... \$21.95

**KEYS OF THE WIZARD**-Super adventure game. Hundreds of rooms filled with treasures, magic spells, traps and puzzles. Save game in progress. 16k.

CASSETTE ..... \$19.95

**GALAX ATTACK**-If you want a challenge, this is it! Patterned after Galaxians. An arcade quality game. 16k and joysticks required.

CASSETTE ..... \$21.95

**SUB HUNT**-As the commander of a destroyer, you must destroy as many enemy subs as you can before they destroy you. 16k extended basic.

CASSETTE ..... \$14.95

**ALCATRAZ II**-No one escapes from Alcatraz II, not even you! Think you can be the first? 16k extended basic.

CASSETTE ..... \$8.95

**LASER COMMAND**-Defend your cities and missile base from the deadly alien lasers. Multiple waves of attackers. 16k extended basic and joystick required.

CASSETTE ..... \$10.95

**COSMIC SUPER BOWL**-Fast action interstellar football. Five skill levels to provide a challenge. One or more players. 16k

CASSETTE ..... \$14.95

**GHOST GOBBLER**-Four relentless ghosts intent on your destruction. Chase your gobbler around this super maze. Best of the pac-man type games. 16k and joysticks required.

CASSETTE ..... \$21.95

**LOTHAR'S LABYRINTH**-An excellent version of the popular word search puzzle. The computer hides up to 48 words on the screen in all directions. Use the computers words or your own. Extended basic.

CASSETTE ..... \$14.95

**PLANET INVASION**-If you enjoy Defender, you will love this one. Lots of fast action. 16k and joysticks required.

CASSETTE ..... \$21.95

**SPACE RACE**-Maneuver yourself around a race track in space, but beware of alien ships, the collectors, swarms and bezekers they are all out to do you in.

CASSETTE ..... \$21.95

**DEFENSE**-If you like Polaris and Missile Command this game is for you. A must for your collection. 16k and joystick required.

CASSETTE ..... \$21.95

**PIRATES AHOY**-Find a sunken ship and treasures in this witty and humorous text adventure. 32k.

CASSETTE ..... \$9.95

**ESCAPE FROM PRISON CITY**-Explore the Prison City where your spacecraft has been shot down. You must find a battery for your spacecraft in order to escape. 16k extended basic.

CASSETTE ..... \$8.95

**COLOR ZAP**-Super space game! Dodge incoming photon torpedos before they penetrate your defenses. 16k and joysticks required.

CASSETTE ..... \$9.95

## TOM MIX SOFTWARE

**BIRD ATTACK**-Shoot the birdmen before they descend upon you. Watch out for their droppings. 16k extended basic.

CASSETTE ..... \$21.95

**DONKEY KING**-Exciting sound and graphics, four screens like the arcade game. Never before have you seen a game like this for your Color Computer. The best! Requires 32k.

CASSETTE ..... \$24.95      DISK ..... \$27.95

**WAR KINGS**-Shield your castle against cannonball attack and deflect them towards your opponents castle. 16k extended basic and joysticks required.

CASSETTE ..... \$19.95

**PROTECTORS**-Enemy fighters drop bombs on your city. Destroy them before they destroy your city. Just like the Defenders arcade game. Requires 32k.

CASSETTE ..... \$24.95

**KATERPILLAR ATTACK**-A fast-paced arcade game. Rave reviews by color computer magazines. 16k and joysticks required.

CASSETTE ..... \$24.95

## COMPUTERWARE®

**STARSHIP CHAMELEON**-You must defend your planet against attack. You have the ability to change color in order to destroy on-coming bombs and anti-matter. Nine levels of play.

CASSETTE ..... \$24.95      DISK ..... \$29.95

**STORM**-A real TEMPEST of a game. Exciting and colorful. 15 battlefields, 9 levels of play.

CASSETTE ..... \$24.95      DISK ..... \$29.95

**EL DIABLOERO**-You awake, dazed and confused, in the middle of the desert. You have been learning techniques of sorcery from an old man who lives in these parts. He told you of his enemy, an evil sorcerer, "Diabloero", now your teacher is missing and you are alone! Pure adventure.

CASSETTE ..... \$19.95      DISK ..... \$24.95

**DOODLE BUG**-Your lady bug hustles through an intricate maze of barriers and turnstiles, eating dots, letters and hearts. Exquisite sound and graphics.

CASSETTE ..... \$24.95      DISK ..... \$29.95

**RAIL RUNNER**-Your engineer must scurry over the tracks of the busiest switch yard ever, to rescue the hobos on the other side of the tracks.

CASSETTE ..... \$21.95      DISK ..... \$26.95

**SHARK TREASURE**-You must dive through shark infested waters to bring back treasures from the ocean floor.

CASSETTE ..... \$21.95      DISK ..... \$29.95

**MEGAPEDE**-A very fast version of the Centepede type game. Not for the faint of heart.

CASSETTE ..... \$21.95      DISK ..... \$29.95

## SOFT SECTOR MARKETING

**DEATH TRAP**-As a tank commander it's your job to find a safe passage through the maze of city streets that contain mines and other hazards.

CASSETTE ..... \$19.95

**OKI-PRINT**-Is a basic language program that is designed to do high resolution screen dumps from the Radio Shack or TDP-100 Color Computer, to an Okidata Microline 82A printer. OKI-PRINT will dump any P MODE M, P(N)=MODE, P=PAGE). If the P MODE is 1 or 3 (which are color modes) the printer will attempt to shade the different colors in lighter and darker intensities of black in order to make them more recognizable. Extended basic required.

CASSETTE ..... \$19.95

**DISASSEMBLER 6809**-This is an interactive disassembler that allows you to call and examine subroutines or look at labels in an ASCII mode without losing your place in the disassembly. It is primarily a SCREEN oriented disassembler, but does have printer output capability.

CASSETTE ..... \$14.95

**ANIMATED HANGMAN**-Playing hangman has never been so much fun. He winks..he blinks..he almost lives! An outstanding game for the whole family. Fun and educational.

CASSETTE ..... \$12.95

**CONCENTRATION/CONNECT UP 4**-Concentration is a memory type game. You are trying to match up the screen displays. Connect up 4 is a game where you try to match 4 dots of color in a row, but the person that you are playing with is trying to do the same thing. A game of strategy.

CASSETTE ..... \$9.95

**HURDLERS**-You are a hurdler running down the track trying to clear the jumps. If you miss, you fall flat on your face. Requires 16k extended basic.

CASSETTE ..... \$14.95

**SHIPWRECK**-Your stranded on a deserted island and your only hope for escape is your own wits and cunning. Can you find your way back to civilization? 16-32k.

CASSETTE ..... \$14.95

**INTRACOLOR**-It's up to you to destroy the Colorpede, knock out the bouncing bug and eliminate toad stools. Excellent version of the Centepede game.

CASSETTE ..... \$29.95      DISK ..... \$34.95

## QUALITY SOFTWARE

**SHIPWRECK**-Your stranded on a deserted island and your only hope for escape is your own wits and cunning. Can you find your way back to civilization? 16-32k.

CASSETTE ..... \$14.95

## INTRACOLOR

**COLORPEDE**-It's up to you to destroy the Colorpede, knock out the bouncing bug and eliminate toad stools. Excellent version of the Centepede game.

CASSETTE ..... \$29.95      DISK ..... \$34.95

## MARK DATA

**HAYWIRE**-An exciting combination of angry Robots and the indestructible Menace will provide hours of challenge. The classic Bezerk type game. 16k.

CASSETTE ..... \$24.95

**CALIXTO ISLAND**-A challenging sometimes humorous excursion to find stolen treasure.

CASSETTE ..... \$19.95

**THE BLACK SANCTUM**-You are pitted against the forces of Black Magic in this spooky adventure. 16k.

CASSETTE ..... \$19.95

**CAVE HUNTER**-Maneuver your way through a spooky cave to retrieve the treasures at the bottom. 16k and joystick required.

CASSETTE ..... \$24.95

**ASTRO BLAST**-Here's the space shoot'em up you've been asking for. 16k.

CASSETTE ..... \$24.95

**SPACE RAIDERS**-A sensational rendition of the arcade classic Invaders. Selectable skill levels. 16k.

CASSETTE ..... \$24.95

**HOW TO ORDER BY MAIL:** For prompt and courteous shipment. SEND MONEY ORDER, CERTIFIED CHECK, CASHIERS CHECK, MASTERCARD/VISA (include card number, inter-bank No., expiration date and signature). PERSONAL AND BUSINESS CHECKS MUST CLEAR OUR BANK BEFORE PROCESSING. Shipping and packing charge of \$2.50 minimum must be added to all orders in continental US (Canadian orders \$5.00 minimum). Michigan residents include 4% sales tax. 10% deposit required on C.O.D. orders.

**COLOR BONANZA**  
**50 Programs - 6 Cassettes**  
**Some 4K \* Some 16K \* Some 32K**  
**Games - Educational - Utilities**  
**FUN FOR THE WHOLE FAMILY**  
**Only ..... \$49.95**  
 Plus \$2.50 Shipping

**MasterCard** **VISA** **CoCo Warehouse**  
 Where Shopping By Mail Is "USER FRIENDLY"  
**500 N. DOBSON WESTLAND, MI 48185**  
**Phone (313) 722-7957**

WRITE FOR OUR  
**FREE CATALOG**

## Dump to Camera: Photographing Your Monitor

By Bruce Rothermel

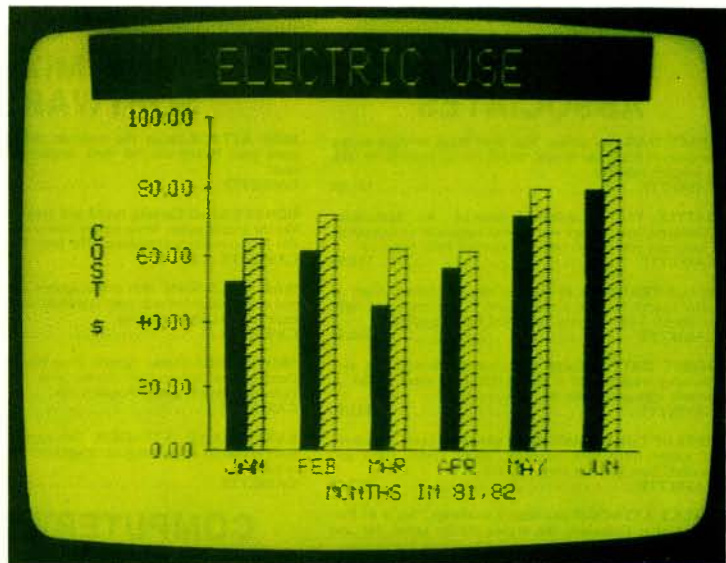

Photo by Bruce Rothermel

You and your Color Computer have just created the world's most interesting graphic on the TV screen. Now what? How do you save it? How do you use it?

One option would be to print the graphic screen on the printer using a screen print program and a graphics printer, but what happened to those breathtaking colors and those crisp fine details? All gone.

Printers are quite limited in their ability to faithfully capture the image as it appeared on the screen and you kiss your colors goodbye. They're not called Color Computers for nothing.

As an alternative, why not photograph your screen? By doing so, you can produce slides or prints of the screen which will capture and retain all the detail and color of the original. Besides, it's a lot easier carrying a photo than a 13" TV set.

### Here's What You'll Need:

- 1) A 35mm SLR camera with a "normal" (50 or 55mm) lens. The SLR means single lens reflex—a camera that ensures that what you see thru the viewfinder is what you get on film.
- 2) A tripod.
- 3) A cable release if the camera doesn't have a self timer.

### Here's How To Do It:

- 1) Create your masterpiece on the screen.
- 2) Adjust the color and contrast settings on the TV set to obtain the densest colors available (highest color saturation) without color fringing. You may have to reduce contrast to do so.
- 3) Mount your camera on the tripod and adjust the height so the camera lens is level with the center of the screen.
- 4) Move the tripod forward and backward until the screen image is filling the viewfinder frame vertically (up and down). There will be additional space on the sides of the viewfinder since the film frame is wider than the graphics screen, but that's okay.
- 5) Focus. Since you have a fixed image size, you may end up

moving the tripod forwards or backwards a little. With a 13" TV screen, your camera will be about 2.5 ft. away from the screen.

6) Exposure. Now comes the tricky part. Shooting an image from a TV screen is different from taking a snapshot of your girlfriend on a sunny day. First, the light balance is different. Your camera meter wasn't made to be sensitive and accurate to this spectrum. Second, the image on-screen is created by a continuous series of lines (rasters) which because of visual retention look like a solid picture.

The camera has no such memory behind its lens. So, here's what to do:

Set the shutter speed to 1/15 of a second. Any speed faster than 1/30 of a second will catch a raster (don't you like these tech terms) and you will see the scan line.

Turn off the lights and eliminate all sources of glare on the screen. A darkened room is best. Take an exposure reading of the screen. Using ASA 64 film (more about this later) you should have an F-stop of about F/8.

Use a cable release or the self-timer and squeeze off your first exposure. Write down this exposure combination for review later.

7) Bracket your exposures. The trick of the pros is to shoot a lot and throw the bad ones away.

Most of the time, the meter will be misled in making an underexposed picture. So, for the second exposure slow down the shutter one speed to 1/8 of a second to increase the exposure time. Keep the same aperture, or E/stop setting, as the first exposure and shoot again. Record this setting.

Next, slow the shutter one more notch to 1/4 second and shoot again. Record these settings. Just to be sure, go back to the original setting (in this example 1/15 sec. at F/8) and close the lens one stop to F/11. Shoot and record this info. (We bracketed in the other direction—more exposure by opening the aperture to keep the shutter speed slow. Remember those rascal rasters.)

Here's a summary of what happened:  
 1st exposure — 1/15 sec. @ F/8 base exposure setting  
 2nd exposure — 1/8 sec. @ F/8 2X 1st exposure  
 3rd exposure — 1/4 sec. @ F/8 4X 1st exposure  
 4th exposure — 1/15 sec. @ F/11 1/2 1st exposure  
 8) Get the film developed and look at the results. Most likely the second exposure will be most pleasing, but whatever looks best will then be your base exposure. From then on you only have to bracket one shutter speed, one F/stop on each side of the base setting.

Remember, always bracket—no matter how good you are. Film is cheap.

9) Speaking of film. Naturally, the type of film you use will depend on the results wanted.

To obtain slides for projection, I would recommend Kodachrome 64 (ASA 64). TV screens tend to photograph blue and Ektachrome and Fuji increase this effect.

For prints, Kodacolor 100 works fine. Plus-X is great for black and white (ASA/ISO 125) and Plus-X negatives can be mounted and projected as a reversed slide. Sort of like a reverse screen print. This is very useful with graphs and charts like those generated by *bar zapper*.

There are many exotic high contrast films available, but start with these basics and experiment.

10) Filtration. If the photographs are still too blue add a filter to the lens. A sky 1A adds a little warmth, an 81A really corrects it.

That's it. The sure fire way to wow 'em with knockout photos generated by you and your 80C.



Hint...

## Which Board Do You Have?

We've received a lot of calls and letters, too, asking, "How can I determine what circuit board I have?" These questions come mainly from those contemplating a memory upgrade. A good clue is provided by keying in *EXEC 41175* which will tell you if you have the 1.0 or 1.1 version of the BASIC ROM chip. If you have a 1.1, says Dennis Lewandowski of DSL Computer Products, then "there's about a 98 percent chance that it's an E board rather than a D or the even newer board," which has a small RF shield housing, often called the F board.

Radio Shack says you have to open up your CoCo to find out for sure, but here at *the Rainbow*, we found that a flashlight and a "peek," using your own two eyes is quite easy. If you will shine a flashlight down into the air vents on the right side (the side on which the ROM port is located) you can see the model number of the board. Look straight down under the first air vent opening (nearest the keyboard). Do you see the green numbers on a black background? Well, the suffix after the hyphen is the board model. You should see a D or an E after the numbers.

Now, if you have a TDP-100, you have the latest board (a.k.a. F board). If you have a fairly new Radio Shack CoCo, take a look inside the ROM port says Ron Krebs of Mark Data Products. Just open it up and peer in. If all you can see is metal, then you have a D or an E board, but if you can see components, then you have the newest board.

# TALK IS CHEAP.

You want your color computer to talk, but how much will it cost?

\$50? \$100? \$200? No.

**\$29<sup>95</sup>?**

Yes! **SPEAK UP!**<sup>™</sup> from *Classical Computing, Inc.* is a machine language



Voice Synthesizer program for your TRS-80 Color Computer.\* It is 100% software. Nothing else to buy. Best of all, YOU CAN MAKE BASIC PROGRAMS TALK! It's easy to use, and will say virtually anything.

**SPEAK UP! For \$29.95.**

**Talk really is cheap!**

*Classical Computing, Inc.*

P.O. Box 12247

Lexington, Kentucky 40582

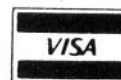

\*T.M. Tandy Corp.

16k minimum



# Why Not Build A Light Pen

By Theodore P. Hasenstaub

Ready to shed some new light on your CoCo? An easy to build (and easy on the wallet) light pen is the answer. A simple light pen consists of a photo cell, resistor, and, well, hmmm. . . that's it! We will add a switch, "pot," case, cord and plug. The CoCo has its own D/A (digital to analog) circuitry built right in, so we are ready to go.

Before we start construction, let's take a closer look at what a light pen actually does. A photo cell can be described as an electrical device, which, on being exposed to different intensities of light, changes its amount of resistance, thus

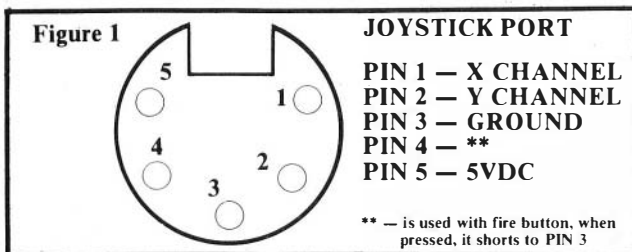

changing the voltage that flows through it. Big deal you say? Well, it is, as you will soon see.

A look at the joystick ports is now in order (Fig. #1). You will see that each port has two input channels. The X channel reads horizontal positions, and the Y channel reads vertical positions (when using joysticks). This is accomplished by using potentiometers. Potentiometers, or pots, are simply variable resistors. In other words, their resistance can be changed by turning the center knobs one way or the other. These two pots are connected together mechanically, so that they both move at the same time. Five volts are applied to one side, and the other side is connected to ground. When the joystick position is changed, it also changes the resistance to the applied voltage (five volts). The center lugs of the pots are connected to the X and Y input channels (Fig. #2). These lines allow the computer to determine joystick positions through its D/A circuitry.

The D/A circuitry consists of an analog switch, or selector, a voltage comparator, and a D/A converter. The selector allows the selection of one of the four input channels (two per joystick port). The voltage comparator then compares two input voltages. One voltage is constant, the other, coming in from the X or Y channel, is not. The D/A converter then approximates the voltage from the channel it is reading. How does this apply to a light pen? Let's build one and see.

First unscrew the white plastic end from the penlight, and remove the bulb and metal contact clip. Now remove the push button switch on the other end. This may be accomplished by pushing it down through the body of the pen with a small piece of rod (be very careful when working with the aluminum body, it is very easy to damage). Next, look into the barrel. Here, you will see a black plastic ring. Push this ring up toward the open end of the barrel. Gently break off the inner part of it, so that all that remains is a ring with a

hole that is large enough in order to remove the rest of the switch. Use a pair of needle nose pliers to do this. Locate a point about 1½ inches from the open end of the barrel. Gently drill a 13/64ths hole at this point.

Now we will wire the light (Fig. #3). I've seen the photo cell in two different cases, one is plastic encased (#276-116), the other one is in a metal can (#276-116A). If you use the plastic one, you will have to file its circumference down so that it fits easily into the pen barrel. The metal one drops right in. Pull the two conductor wires up through the pen case and black ring. Strip off about 8 inches of the outer covering. Cut one lead of the photo cell so there is about 1 inch, and trim the other to about 1½ inches. Slide two pieces of shrink tubing over the cable leads. Solder one lead to the 1 inch side of photo cell, and the other to one side of the switch. Slide another piece of shrink tubing over the other photo cell lead. Solder this lead to the other side of the switch. Now slide the shrink tubing up over all the joints and heat it, so all the connections are insulated. Strip off 4 inches of outer covering on the other cable end. Label the wire that you connected to the switch. Now slide the assembly into the pen barrel, and guide the switch so that the button catches into the hole that you have drilled. A little jiggling around and you will be able to get the switch up into the hole. Install the switch lock nut. Screw on the white end piece, and wrap

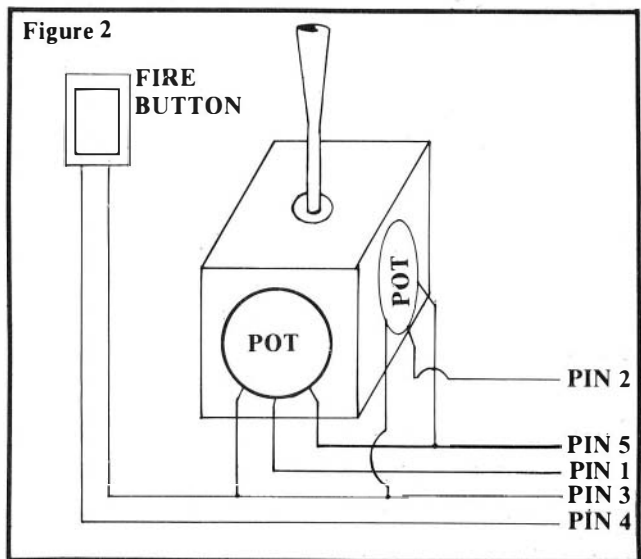

black electrical tape around it, so no white is showing.

Now slide the plug cover onto the cable end and wire as follows. The line that you labeled is soldered to pin #5 of the joystick plug. Cut two pieces of wire about 3 inches long. Label them #1 and #3 and solder them to the corresponding pins on the joystick plug. Assemble the plug and slide the plug cover on. Solder the wire you labeled #3 to the center lug on the pot. Trim the other wire so that the pot lays flat in

Figure 3

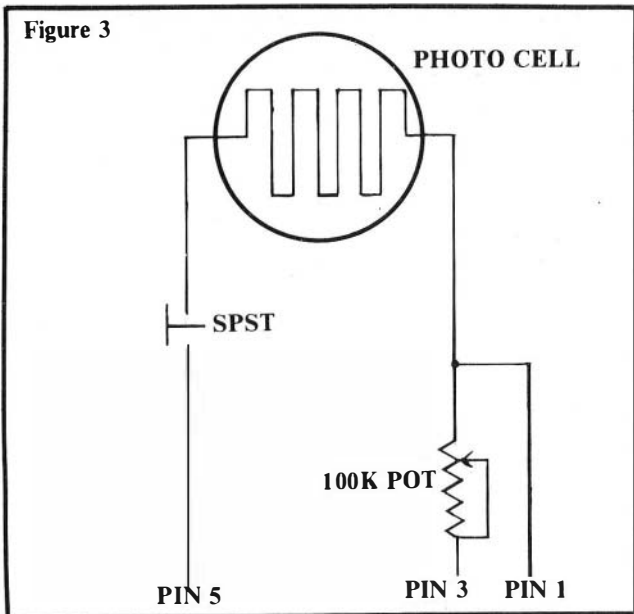

the line, then solder it and the wire you marked #1 to one of the outside lugs on the pot. Wrap electrical tape around these connections.

As I said earlier, a photo cell changes its resistance on exposure to different light levels. The CoCo has nine distinct colors that are available. If you expose the light pen to them, you will find that each color will return a different value. By software control you can use these values as variables, and design a program that will use them.

I have included two programs. One allows you to set your own color value tables, and the other will demonstrate the light pen. The demo program uses color values as variables. I designed the program as a quiz. It will display a question and possible answers. A tone will sound, at this point place the tip of the pen firmly against the TV screen, to the color (answer), you choose. Press the button down and hold it down until the next tone. This allows the photo cell to get a true value reading of the color. The program then checks through a comparison routine to check if the answer is right or wrong. This program can be easily modified for any type questions you may want, by simply changing a few lines in the program. I would be very interested in any input from other readers, on other applications, and software, for using this device.

**PARTS LIST**

- Photo Cell ..... Radio Shack @376-116 or #276-116A (see text) @ \$1.29
- Penlight ..... Radio Shack #61-2626 @ \$1.99
- Switch ..... Radio Shack #275-1571 SPST Normal Open, Momentary
- Joystick Plug ..... Spectrum Projects 93-15 86th Place, Woodhaven, N.Y. 11421 @ \$4.00
- 100K pot, 2 Conductor cable (shielded)

350	032E
650	0701
END	0AC7

**Listing 1:**

```

10 ' LIGHT PEN DEMO
20 GOTO 660
30 DIM D$(40)
40 RESTORE
50 CLS
    
```

```

60 PRINT@230,"STATE CAPITOL QUIZ
";
70 PRINT:PRINT:PRINT:PRINT
80 INPUT"ENTER YOUR NAME---->";N
$
90 FOR Q=1 TO 1380:NEXT Q
100 FOR N=1 TO 40:READ D$(N):NEX
T N
110 W=0:T=0:JY=JOYSTK(0)
120 N=1
130 CLS(0)
140 PRINT@32,"WHAT IS THE CAPIT
OL OF";" ";D$(N);" ";":N=N+1

150 PRINT@161," ";D$(N);" ";:N=N
+1
160 PRINT@257," ";D$(N);" ";:N=N
+1
170 PRINT@353," ";D$(N);" ";
180 FOR V=0 TO 3
190 FOR H=31 TO 37
200 SET(H, 9+V,4):SET(H,15+V,2):
SET(H,21+V,6)
210 NEXT H,V
220 GOSUB 490
230 SOUND 125,5
240 GOSUB 490
250 X=0
260 ' READ COLOR VALUES FROM SCR
EEN
270 FOR B=1 TO 40
    
```

### DISK ZIPPER

COLOR DISK UTILITY PACKAGE

A MENU DRIVEN SYSTEM DISK CONTAINING:

- ERROR CRASHLESS BACKUP: DUAL AND SINGLE DRIVE
- WRITE OR READ ANY SECTOR: CHECK DISK FOR ERRORS
- PAGE DISK THROUGH ANY PMODE WINDOW IN COLOR
- DUMP DISK IN HEX OR ASCII: PRINTER SUPPORTED
- LOAD ML TAPE TO DISK: RELOCATES UNLOADABLES
- WITH COMPLETE MANUAL: REQS 32K RS DISK

ONLY **24.95**

### ARCADE - CONTROLS!

WICO MADE JOYSTICK INTERFACE: TWIN STICKS  
 ALLOWS ANY TWO JOYSTICKS TO WORK ON THE  
 COLOR COMPUTER: ONLY **19.95**

ACC-U-FIRE PADDELS / ATARI-TYPE GAME PADDELS PLUG INTO COLOR -  
 COMPUTER FOR IMPROVING SCORES! WORKS ON HOR. & VERT. GAMES.  
 ONLY \$19.95!

**HARDWARE!**  
 ROMPACK EXTENDER: PUT YOUR DISK PACK  
 WHERE YOU WANT IT: 3 FEET LONG  
 QUALITY CABLE ONLY **27.00**

GREEN - PHOSPHOR ADAPTER / NOW PRINT GREEN ON BLACK SCREEN!  
 ALL HARDWARE, NO SOFTWARE! NO SOLDERING! AND ONLY \$19.95!

WORKS ON ANY TV: SMALL BOARD GOES ON THE  
 RF SHIELD: ONLY THREE WIRE CLIPS

**EPROM PROGRAMMING! 2K, 4K, 8K BYTES**  
 WE WILL PROGRAM YOUR EPROM FOR **5.00**  
 SEND US ONE OF YOUR GAMEPACKS AND WE WILL PUT YOUR  
 PROGRAM IN IT FOR **ONLY 20.00**

**CALL OR WRITE FOR DETAILS**  
**YOU CAN PRINT VIDTEX FROM ROMPACK**

WICO COMMAND CONTROL STICK **28.00** OUR SOFTWARE ALLOWS YOU TO  
 ZAXXON: DATASOFT **34.95** PRINT OFF LINE FROM VIDTEX  
 DONKEY KING ..... \$24.95 WITH SERIAL Y CABLE: 29.95  
 WICO TRACKBALL **88.00** WITHOUT CABLE: 9.95  
 ATARI JOYSTICKS \$6.95/  
 WE CARRY TOM-MIX & MARK-DATA.

**MICRO - DIV.** Toledo, Ohio 43612  
 450 W. LASKEY 1-419-476-6282

ASK FOR MICRO-DIV.

C.O.D. Credit Card  
 orders accepted / add \$2.00 shipping

HAYWIRE ..... 24.95  
 PROTECTORS ..... 24.95  
 ASTRO-BLAST ..... 24.95  
 SPACE RAIDERS ..... 24.95  
 MOON-LANDER E.B. 19.95  
 HAYWIRE ..... 24.95

```

280 X=X+JY:NEXT B
290 J=JOYSTK(0)
300 ' COMPARE COLOR VALUES
310 IF (N=4) OR (N=12) OR (N=24)
OR (N=36) THEN GOTO 340
320 IF (N=16) OR (N=20) OR (N=28)
) THEN GOTO 350
330 IF (N=8) OR (N=32) OR (N=40)
THEN GOTO 360
340 IF (J>21) AND (J<38) THEN GO
TO 370 ELSE GOTO 410
350 IF (J>51) AND (J<58) THEN GO
TO 370 ELSE GOTO 410
360 IF (J>40) AND (J<51) THEN GO
TO 370 ELSE GOTO 410
370 SOUND 125,5
380 PRINT@ 450," THAT IS CORRECT
";N$;" ";:T=0
390 GOSUB 490
400 N=N+1:IF N>40 THEN GOTO 530
ELSE GOTO 130
410 SOUND 125,5
420 T=T+1:W=W+1
430 PRINT@450," THAT IS INCORREC
T ";N$;" ";
440 IF T=1 THEN W=W-1
450 GOSUB 490
460 IF T=1 THEN N=N-3:GOTO130
470 IF T=2 AND N<40 THEN T=0:N=N

```

```

+1:GOTO 130
480 IF T=2 AND N>=40 THEN GOTO 5
30
490 FOR Q=1 TO 1000:NEXT Q
500 RETURN
510 DATA OHIO,COLUMBUS,CLEVELAND
,TOLEDO,KENTUCKY,LOUISVILLE,PROS
PECT,FRANKFORT,TEXAS,AUSTIN,DALL
AS,HOUSTON,ALASKA,FAIRBANKS,JUNE
AU,ANCHORAGE,NEW YORK,NEW YORK,A
LBANY,SYRACUSE
520 DATA MONTANA,HELENA,BILLINGS
,BUTTE, ILLINOIS,CHICAGO,SPRINGF
IELD,PEORIA,KANSAS,KANSAS CITY,W
ICHITA,TOPEKA,MAINE,AUGUSTA,BANG
OR,PORTLAND,MICHIGAN,ANN ARBOR,D
ETROIT,LANSING
530 SC=(10-W)*10
540 FOR Q=1 TO 920:NEXT Q
550 CLS(0)
560 PRINT@226,"YOUR SCORE WAS";"
";SC;"%";" ";N$;" ";
570 FOR Q=1 TO 920:NEXT Q
580 PRINT@298," GAME OVER ";
590 FOR Q=1 TO 1000:NEXT Q
600 PRINT@484," PLAY AGAIN? <Y O
R N> ";
610 Q$=INKEY$
620 IF Q$="" THEN GOTO 610
630 IF Q$="Y" THEN GOTO 40
640 IF Q$<>"N" THEN GOTO 610
650 CLS:END
660 CLS
670 PRINT@6,"LIGHT PEN CALIBRATI
ON
";
680 PRINT"HOLD PEN TIP AGAINST T
HE COLORED";
690 PRINT"BLOCKS ON SCREEN, SLOW
LY ADJUST ";
700 PRINT"THE POTENTIOMETER UNTI
L YOU GET ";
710 PRINT"READINGS THAT CORRESPO
ND TO THE ";
720 PRINT"ONES IN THE TABLE THES
E READINGS";
730 PRINT"ARE NEEDED FOR THIS PR
OGRAM TO ";
740 PRINT"OPERATE PROPERLY. THE
VARIABLES ";
750 PRINT"IN THIS PROGRAM ARE SE
T TO THESE";
760 PRINT"VALUES. CHECK ALL READ
INGS AFTER";
770 PRINT"EACH ADJUSTMENT IS MAD
E. ";
780 PRINT@420," PRESS <C> TO CON
TINUE "
790 Q$=INKEY$:IF Q$="C" THEN GOT
O 800 ELSE GOTO 790
800 CLS(0)

```

## THE SOFTWARE SHOP

(617) 339-3734

*We Specialize In Color Computer Programs  
Call or Write For Our Catalog*

<u>ARCADE STYLE</u>	<u>UTILITIES</u>	<u>EDUCATIONAL</u>
Pac Attac Galax Attax Storm	Tape to Disk Disassembler Assemblers	Spelling Math Geography
<u>ADVENTURE</u>	<u>PERSONAL</u>	<u>BUSINESS</u>
Madness & Minatour Keys of the Wizard El Diablaro	Budget Household Expense Stock Analysis	Word Processing Inventory Gen. Ledgers

*Over 100 Different Programs in Stock!*

## THE SOFTWARE SHOP

200 Chauncy Street  
Mansfield, MA 02048

\*Visa and M.C. Accepted\*



# FLEXPLUS DOS.....\$69.95

**A Powerful, easy-to-use disk operating system!**

**\*FREE\* COLOR COSMIC INVADERS—FREE on every FLEX+ DISK \$21.95 Value.**

**FLEXPLUS** is a powerful, easy-to-use disk operating system. Spectral Associates has adapted TSC's FLEX to the best DOS completely compatible with Radio Shack software for use on the Color Computer. Eliminate the need for Radio Shack's TRS DOS — use **FLEXPLUS** with Editor/Assembler and have the options of a full range of utilities. **FLEXPLUS** works on the 32K Radio Shack disk system with 64K memory chips with a High Resolution multi-screen format that supports a 24 line by 51 character display! Also included are special enhancements to Radio Shack's Disk system when you are running FLEX with single or double sided, single or double density, 35, 40 and 80 track drives.

## Advantages of FLEXPLUS DOS

- Best price anywhere
- Wealth of existing software
- Easy start-up — just type "RUN FLEX +"
- Print Spooling — print while editing, assembling, etc.
- Allows you to save RS compatible binary disk files from **FLEXPLUS**
- NO HARDWARE MODIFICATIONS NEEDED
- Warranty will not be voided — no need to open computer
- All FLEX compatible software will run including INTERRUPT DRIVEN SOFTWARE
- Requires Supercharger board
- \$149.95 for **FLEXPLUS**, Editor/Assembler and Supercharger

## SUPERCHARGER

Allows machine language access to all 64K RAM in a Series E PC board. No hardware mods.

**\$39.95**

## KEYS OF THE WIZARD

Best new adventure game! Over 200 rooms filled with creatures, tricks, treasures and magic spells. Cassette save feature built-in.

**\$19.95**

## MAGIC BOX

Special utility design to load MOD I/III Level II 500 baud BASIC programs into color computer.

**SUPER PRICE \$24.95**

For orders only, call toll-free

# 1-800-426-1830

Except WA, AK, HI

Business Office and Information

Call **206-565-8483**

Office open 8:30-4:30 P.S.T.

We accept VISA, MASTERCARD, AMERICAN EXPRESS.

**FLEXPLUS.....\$69.95**

for new F Boards

**FLEXPLUS with Supercharger.....\$89.95**

for use with E Boards

**FLEXPLUS with Supercharger and Editor / Assembler ..... \$149.95**

## ULTRA 80CC (Editor / Assembler)

Features:

- TRS CC DOS compatible
- Library Files
- Macros
- Conditional Assembly

Most powerful disk-based editor/assembler for the Color Computer available (requiring 32K) and a "must" for anyone considering the development of machine language programs. Complete with 68-page documentation.

FANTASTIC PRICE

**\$49.95**

## ORACLE (Graphic Monitor)

Tired of writing machine language programs with no way to debug them easily? Your problems are solved, the ORACLE is here.

ONLY **\$29.95**

## GREAT BASIC GAMES

ALCATRAZ II  
C-TREK  
GAME PACS  
GAMBLIN GAMES  
PIRATES AHOY  
DESERT GOLF  
YAHTCC

ESCAPE FROM PRISON CITY  
SUB HUNT  
LASER COMMAND  
SPACE TRADERS  
BATTLE FLEET  
LOTHAR'S LABYRINTH  
MAZE ESCAPE

ARCADE GAMES • ADVENTURE GAMES  
BASIC GAMES • UTILITIES • BOOKS  
HARDWARE • MODEMS

Call or write for a complete catalog.

## Quality Hardware

### and Software Support

### TRS-80 COLOR COMPUTER

### TDP SYSTEM 100

### DRAGON 32

WA residents add 7.8% sales tax

Add 3% for shipping. NO C.O.D.

All prices U.S. FUNDS.



# SPECTRAL ASSOCIATES

3416 South 90th

Tacoma, WA 98409



**PRICKLY-PEAR SOFTWARE**  
**QUALITY PROGRAMS FOR YOUR COCO**  
**& TDP-100**

PROGRAMS REQUIRE 16K EXTENDED BASIC FOR  
 TAPE, AND 32K DISK UNLESS OTHERWISE NOTED.

**NEW THIS MONTH**



**Jungle**

If you are out for a stroll, what better place than a jungle? After all, the scenery is nice, and there are all those pretty birds and flowers and snakes... Did I say snakes? I meant to say spiders... or was it headhunters? Anyway, there's always something interesting in the jungle! All you have to do is take a little hike from one place to another. Did I mention it was quite a distance? That's no problem though, because you have 10 bearers to carry your equipment... as long as nothing happens to them. That's it, then. All you have to do is hike down the trail a piece. I never have any trouble in the jungle myself. Of course, I've never actually been in the jungle, but I'm sure if you talked to any of the people who have made this trip, they'd tell you it was just a pleasant walk. In fact, if you see any of those people, let me know. I always have wondered why we never heard from any of them again... If you are ready for a real fun challenge, don't miss JUNGLE. The game is all text, but your imagination will provide plenty of graphics!! **TAPE - \$19.95, DISK - \$24.95**

Your Personal check is welcome - no delay. Include \$1.50 shipping for each program ordered. (Shipping free on \$50.00 or larger orders). Az. residents add 6% sales tax. Orders shipped within two days.

At your local dealer, or send order to:  
**PRICKLY-PEAR SOFTWARE**  
 9822 E. Stella Road  
 Tucson, Arizona 85730  
 (602) 886-1505

```

810 PRINT@5," RED "; :PRINT@13,"
  YELLOW ";;:PRINT@23," CYAN ";
820 FOR V=4 TO 8
830 FOR H=0 TO 6
840 SET (11+H,V,4):SET (29+H,V,2):
  SET (47+H,V,6)
850 NEXT H,V
860 PRINT@484," PRESS <D> WHEN D
  ONE ";
870 PRINT@245," VALUES ";
880 PRINT@257," READINGS ";
890 PRINT@302," RED >21 & <38
  ";
900 PRINT@366," YELLOW >51 & <58
  ";;:PRINT
910 PRINT@430," CYAN >40 & <51
  ";
920 Q$=INKEY$:IF Q$="D" THEN GOT
  O 30
930 X=0
940 FOR Y=1 TO 40
950 X=X+JOYSTK(0)
960 NEXT Y
970 X=X/40
980 PRINT@356,JOYSTK(0);
990 GOTO920
  
```

**Listing 2:**

**DEFINE(LIGHT PEN)**

```

5 * DEFINE NEW COLOR VALUES
10 CLS(0)
20 FOR V=1 TO 7
30 FOR H=0 TO 8
40 SET (5+H,V,1):SET (19+H,V,2):SE
  T (35+H,V,3):SET (49+H,V,4)
50 NEXT H,V
60 FOR V=17 TO23
70 FOR H=0 TO 8
80 SET (5+H,V,5):SET (19+H,V,6):SE
  T (35+H,V,7):SET (49+H,V,8)
90 NEXT H,V
100 PRINT@486," PRESS <D> WHEN D
  ONE ";
110 Q$=INKEY$
120 IF Q$="D" THEN 200
130 X=0
140 FOR Y=1 TO 40
150 X=X+JOYSTK(0)
160 NEXT Y
170 X=X/40
180 PRINT@206,JOYSTK(0);
190 GOTO 110
200 CLS:END
  
```



## THE STEREO COMPOSER

NEW  
PRODUCT!

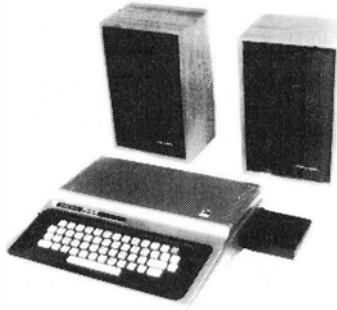

The **STEREO COMPOSER** music synthesizer was developed for the true music lover. All the features available for the **COMPOSER** described below are also available for the **STEREO COMPOSER**. However, instead of using the single 6 bit digital to analog converter built into the computer and the speaker built into your TV, the **STEREO COMPOSER** uses two 8 bit digital to analog converters which drive two audio power amplifiers. These amplifiers supply enough audio power to easily drive your own external speakers. If you like, the output may be connected to your home stereo system to further increase fidelity. Connection is provided by two phono connectors. If the music is too loud, two built-in volume controls are provided to allow you to control the volume of each of the channels separately. The advantage of being able to use external high quality speakers is obvious. The use of higher quality digital to analog converters serves to further increase music fidelity.

The **STEREO COMPOSER** produces music in stereo. Of the 4 voices produced, 2 are directed to each channel. This ability alone increases the realism of the music. You can even move the voices between speakers as the music plays.

The **STEREO COMPOSER** comes assembled, tested, burned in, with all the software and hardware to allow you to immediately start enjoying your music. A complete manual and examples are provided to give you everything you need to know.

The **STEREO COMPOSER** is completely memory decoded so it does not conflict with the Radio Shack disk controller. In this way, disk owners with an expansion interface such as the BT-1000 by Basic Technology can produce music from disk with the **STEREO COMPOSER** in one slot and the disk controller in another. In fact, you can even have **THE VOICE** in another slot without any fears that there will be memory conflicts.

Requires Extended BASIC and Minimum of 16K  
Specify Cassette or Disk

STEREO COMPOSER (Hardware and Software) .....\$119.95



## THE COMPOSER



The **COMPOSER** is a 4 voice music compiler which easily allows one to develop high quality music. Each voice is programmed separately. In addition, each voice uses its own waveshape table which means a unique sound for each of the 4 voices.

The **COMPOSER** features a 7 octave range. It supports dotted and double dotted notes as well as eighth, quarter, and standard triplet notes. Sixteenth and thirty second notes are also supported.

The **COMPOSER** allows the music to be played at any tempo and in any key. And believe it or not, the tempo and key can be modified as the music plays. This gives the user tremendous versatility in developing music. Key modification also allows the user to move the music up or down one or more octaves.

The **COMPOSER** displays a constantly changing random kaleidoscope pattern as the music plays. In addition, the number of the note being played is displayed which aids one in finding sour notes during music development. Both of these displays can be disabled to allow any screen to be displayed while the music is playing. In this way, one can show the words to a song or display a picture as the music plays.

The **COMPOSER** develops a machine language position independent subroutine that can be Saved, Loaded, and Executed independent of all other software. This means that you can share your music with friends. In fact, you can write your own BASIC programs that call and play the music. Software vendors may include the music in their own product.

The **COMPOSER** is menu driven making it extremely easy and friendly to use and operate. A thick operating manual is also provided. Many examples are given to aid the user in getting started. All you need is provided, no additional hardware is necessary. Don't let the price fool you, the **COMPOSER** has got to be heard to be appreciated.

Requires Extended BASIC and Minimum of 16K

CASSETTE VERSION .....\$24.95  
DISK VERSION (32K) .....\$29.95

## THE VOICE

NEW  
PRODUCT!

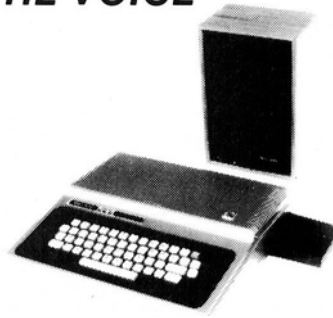

**SPEECH SYSTEMS** got its start providing high quality speech synthesizers for SS-50 bus computers. We are now proud to announce the same high quality product for the Color Computer and TDP-100.

**THE VOICE** should not be mistaken with software speech synthesizers which require the computer to do all the work in producing speech.

**THE VOICE** uses a special large scale integrated circuit, the SC-01 by VOTRAX, to reproduce any one of 64 phonemes at 4 inflections. Phonemes are basic units of speech which allow one to reproduce any word in English as well as many other languages.

**THE VOICE** has two outputs. Speech may be heard through the user's TV speaker, or the built-in audio power amplifier may be connected to your own external speaker. A phono connector is provided for this purpose and if the volume is too high, a built-in volume control may be used to adjust it to the proper level.

**THE VOICE** comes assembled, tested, burned in, with all the necessary hardware and software. A complete manual with many examples are provided to get you started in developing your own BASIC or machine language programs to use speech.

**THE VOICE** is completely memory decoded so it does not conflict with the Radio Shack disk controller. In this way, disk owners with an expansion interface such as the BT-1000 by Basic Technology can produce speech from disk with **THE VOICE** in one slot and the disk controller in another. In fact, you can even have the **STEREO COMPOSER** in another slot without any fears that there will be memory conflicts.

We are trying to develop a library of software for **THE VOICE**. Toward this end, we will be offering substantial royalties to software authors for their work.

Requires Extended BASIC and Minimum of 16K  
Specify Cassette or Disk

THE VOICE (Hardware and Software) .....\$179.95

## HOW TO ORDER

We accept CASH, CHECK, COD, VISA, and MASTER CARD orders.

Shipping and handling for all products in the continental US and Canada .....\$2.00

Shipping and handling for all products outside the continental US and Canada .....\$5.00

COD charge (requires cash, certified check, or money order) .....\$2.00

Illinois residents purchasing the **STEREO COMPOSER** or **THE VOICE** please add 5 1/2% sales tax.

Dealer Inquiries Invited

SPECIALISTS IN SYNTHESIZERS  
FOR THE COLOR COMPUTER AND TDP-100.

*Speech Systems*

38W255 DEERPATH ROAD  
BATAVIA, ILLINOIS 60510

(312) 879-6880

CALL ANY DAY, ANYTIME TO ORDER. YOU MAY ALSO ORDER BY MAIL.





# Exercise Your Strings With This Vowel Checker

By Steve Blyn  
RAINBOW Education Editor

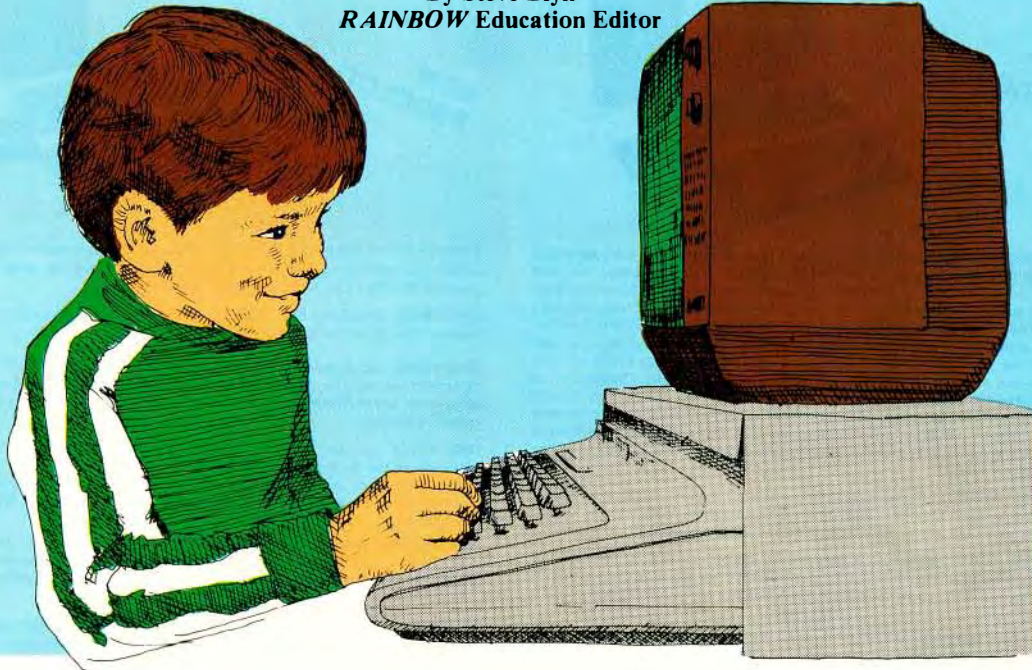

This month we will investigate further how string manipulations can help to build language based programs. Strings are usually words, and words are the building blocks of language. Many Language Arts and Foreign Language programs can be developed after a basic knowledge of string manipulation is obtained. It has often been stated that "without string handling capabilities, a computer is just a super calculator." Although exaggerated, there is a lot of truth in that statement.

All strings have a left side, a middle, a right side and a length. We can thus examine all portions of the string using the string functions—LEFT\$, MID\$, RIGHT\$, and LEN. If we set A\$ equal to the word computer, then:

LEN A\$ would be equal to 8  
LEFT\$(A\$,1) would = "C"  
RIGHT\$(A\$,1) would = "R"  
LEFT\$(A\$,3) would = "COM"  
RIGHT\$(A\$,2) would = "ER."

Let's check this out on your computer.

```
10 CLS
20 A$="COMPUTER"
30 PRINT LEN(A$)
40 PRINT LEFT$(A$,1)
50 PRINT RIGHT$(A$,1)
60 PRINT LEFT$(A$,3)
70 PRINT RIGHT$(A$,2)
80 LIST
RUN
```

MID\$ is even more impressive. It can check any portion of the string.

MID\$(A\$4,2) would = "PU." The 4 tells the computer to begin at the fourth letter and the 2 tells how many letters to include.

MID\$(A\$2,3) would = "OMP." Print MID\$(A\$,2,3) to check this out. Try checking out some of your own combinations before going on.

The computer can build up or break down strings in any fashion we choose. Let's build up the words COLOR COMPUTER adding one letter at a time.

```
10 CLS
20 A$="COLOR-COMPUTER"
30 FOR T=0 TO LEN(A$)
40 PRINT LEFT$(A$,T)
70 NEXT T
RUN.
```

As the (T) value is increased by 1 in lines 30 and 70, the next letter in the word gets added on until the whole word is built up to its entire length...LEN (A\$)

The computer can also check out and act on each letter as it is going through the list. Let's have it check for any letter "O"s. To accomplish this, we will add lines 50 and 60 to the above program.

```
50 B$=LEFT$(A$,T)
60 IF RIGHT$(B$,1) = "O" THEN SOUND 220,3
RUN the program once again.
```

Line 50 checks our progress on the string construction leftwards, and line 60 makes a sound if an "O" is the rightmost letter at that time. Thus, every time an "O" is found at the right end of the word as it is being built up, a sound is made.

If the letter "O" can be checked, then so can any other characters. The program that follows is a vowel counter. The child may *INPUT* any word, phrase, or sentence that he wishes. He is asked to count the number of vowels. The program checks for the vowels A, E, I, O, and U.

The Y is more difficult to check because there are quite a few cases where Y is or is not used as a vowel. We chose to include only one instance when Y could be a vowel—if it is at the end of a word and it is not preceded by a vowel, then Y is counted as a vowel. This is done on line 0. An example would be FLY. Trying to work out additional times when Y is counted as a vowel, (such as when there are no other vowels in the word), is excellent practice in exercising your string muscles.

By slightly altering the methods outlined here, many other Language Arts and Foreign Language exercises can be developed. By using LEFT\$(A\$,2) or LEFT\$(A\$,3), prefixes or foreign language articles can be checked. Using RIGHT\$(A\$,2) or RIGHT\$(A\$,3) can check for suffixes, endings, or plurals. The MID\$ function could permit checking for root words or particular letters as was done in this article.

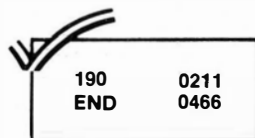

The listing:

```

10 REM "VOWEL COUNTER"
20 REM "STEVE BLYN-COMPUTER ISLAND
30 CLS
40 PRINT"WHAT IS YOUR NAME";:INP
UT NA$
50 N$=LEFT$(NA$,12)
60 X=0:T=0:M=0:H=0
70 CLS
80 PRINT"TYPE IN ANY WORD ";N$
90 PRINT:INPUT A$
100 REM"*** BREAK THE WORD UP IN
TO SUCCESSIVELY LONGER PORTIONS"
110 FOR T= 1 TO LEN(A$)
120 H=H+1
130 B$=LEFT$(A$,H)
140 REM"*** CHECK FOR VOWELS-
A,E,I,O,U"
150 IF RIGHT$(B$,1)="A" OR RIGHT
$(B$,1)="E" OR RIGHT$(B$,1)="I"
OR RIGHT$(B$,1)="O" OR RIGHT$(B$
,1)="U" THEN X=X+1:GOSUB 380
160 NEXT
170 REM"CHECK FOR THE NEXT TO LA
ST LETTER IF THE LAST LETTER IS
A "Y"
180 L=LEN(A$)-1
190 IF L<1 THEN 220
200 L$=MID$(A$,L,1)
210 IF RIGHT$(A$,1)="Y" AND L$<>
"A" AND L$<>"E" AND L$<>"I" AND
L$<>"O" AND L$<>"U" THEN X=X+1:G
OSUB 380

```

```

220 PRINT
230 PRINT"TYPE THE NUMBER OF VOW
ELS IN THE WORD ";A$;" ";N$::INP
UT Y
240 PRINT:IF Y=X THEN SOUND180,1
:SOUND200,1:PRINT"CORRECT ";N$:G
OTO 360
250 REM"*****LET'S KEEP OUR
GRAMMAR STRAIGHT HERE"
260 PRINT
270 PRINT"          SORRY, ";N$
280 SOUND20,4:SOUND10,4
290 IF X=1 THEN PRINT"THERE IS";
300 IF X<>1 THEN PRINT"THERE ARE
";
310 PRINTX;"VOWEL";:IF X<>1 THEN
PRINT"S";
320 PRINT" IN THE ":PRINT"WORD -
";A$
330 IF X=0THEN 360
340 IF X=1 THEN PRINT"IT IS - "
V$(1):GOTO360
350 PRINT"THEY ARE ";:FORM=1TOX
:PRINTV$(M);" , ";:NEXT
360 PRINT@448,"PRESS <ENTER> TO
GO ON";:INPUT EN$
370 GOTO 60
380 V$(X)=RIGHT$(B$,1):RETURN

```

## POWER LINE PROBLEMS?

### SPIKE-SPIKER® ...THE SOLUTION!

Protects, organizes, controls computers & sensitive, high tech electronic equipment. Helps prevent software "glitches", unexplained memory loss, and equipment damage. Absorbs damaging voltage spikes & surges, reduce costly equipment downtime. Filter models attenuate conducted RF interference. 120V, 15 Amps. Other models available. Ask for free literature for detailed specs. Call your order in today!

**DELUXE POWER CONSOLE**  
**\$79.95**  
Transient absorber, dual 5-stage filter. 8 individually switched sockets, fused, main switch, and lite.

**QUAD-II \$59.95**  
Transient absorber. Dual 3-stage filter. 4 sockets, lite.

**QUAD-I \$49.95**  
Transient absorber, 4 sockets, lite.

**MINI-II \$44.95**  
Transient absorber, 3-stage filter, 2 sockets, lite.

**MINI-I \$34.95**  
Transient absorber, 2 sockets, lite.

Use your credit card or send check & we pay the shipping.  
**215-837-0700**  
Out of state, order toll free  
**800-523-9685 • TWX 510-651-2101**

PA Res. add 6% sales tax • for COD add \$3.00 + shipping • dealers invited



## Write An ML Program To Handle BASIC Chores

By

D.S. Lewandowski

Rainbow Contributing Editor

First of all, we should establish that programming in assembly language is *not* the same as machine language. In assembly language we use an Editor/Assembler to enter our program into a text buffer. Once finished the Assembler will transform our text into a machine language program. Learning assembly language has nothing to do with the amount of skill you can demonstrate in BASIC programming, or any other computer language. The finished product, a machine language program, will be as short, or as long, as necessary to accomplish a task you have set for the computer to perform. There is no magic, or mystery to programming in any computer language. Mostly, practice will make you proficient with assembly language. It really boils down to a logical thought process. Just take your programming idea, and break it into sub-tasks (or bite-size pieces, if you prefer). Tackle each sub-task one at a time. Sometimes a sub-task will be a bit too much so, again, break this sub-task into further sub-tasks. On the other hand, you may solve two, or more, sub-tasks with one solution.

Starting this month, our task is going to be: Write a machine language program which will perform the same task as a BASIC program. So, here is the first BASIC listing:

### Listing 1:

```

10 CLS
20 I$=INKEY$ : IF I$="" THEN 20
30 I=VAL(I$) : IF I<0 THEN I=0
40 IF I>8 THEN I=0
50 CLS(I) : GOTO20
    
```

What will this program do? Line 10 will clear the screen to the color green. Line 20 will scan the keyboard, and wait until a key is pressed. Once a key has been pressed, Line 30 will take the value of the string variable and convert it into a numeric variable (I). Line 30 will also check to see if the value of I is less than zero. Line 40 checks the upper limit of the CLS command, it checks for a value greater than eight. In both cases, if I is less than zero, or I is greater than eight, I is set to zero. Line 50 clears the screen to the color value of I, then restarts the routine by going to Line 20.

Okay, what we need to do is see what we need. We need to clear the screen. We need to get a keypress from the keyboard. We have to check the keypress and see if it falls into the range of zero and eight. Finally, we need to clear the screen to the color value of a valid keypress, or clear it to zero in all other cases. That seems enough sub-tasks. To solve the first one, let's remember that BASIC has a clear screen routine. The address of this routine is \$A928; this information is available from sources such as *the Rainbow*. Let's pause a moment and disassemble this routine, I will provide the comments.

A928/	LDB	#\$60	Load the B register with \$60
A92A/	LDX	#\$400	Load X with screen start
A92D/	STX	<\$88	Update cursor position
A92F/	STB	,X+	Store the value in B at the location X is pointing at and increment X by one
A931/	CMPX	#\$5FF	Check for last screen byte
A934/	BLS	\$A92F	Loop to STB ,X+ until done
A936/	RTS		Return from routine

Well, this provides us with a simple method of clearing the screen. Also, if we load B with the correct value, we can simply jump to the routine at \$A92A, to put the value in B on the screen. That's pretty handy.

How about getting a keypress? Another ROM routine? Sure, why not? The routine which most resembles the *INKEY* command of BASIC is located at \$A1C1. This routine will return the value of the keypress in the A register. The value of the keypress is in ASCII. On an ASCII conversion chart, zero to eight are represented as \$30 to \$38. If we subtract \$30 in each case, we will end up with the correct values we need for this task. Hmmm, the graphic blocks which correspond to the color values are: CLS(0) = \$80,

**Chattanooga Choo Choo Software**  
 Your One Stop Station  
 For Computer Programs



Track 29

**FREE SOFTWARE!**

Get your name on our mailing list and our CoCo could choose you to receive **\$100.00 Credit** toward software from our line.

Another name will be chosen to receive a one-year subscription to the *Rainbow*.

Winners will be notified in May and announced in June *Rainbow*.

**DEADLINE APRIL 30, 1983**

<b>DATASOFT</b>	<b>ANTECO SOFTWARE</b>
*ZAZZON (32K) <del>\$39.95</del> \$35.95	INTERGALACTIC FORCE \$24.95
*MOON SHUTTLE <del>\$24.95</del> \$31.45	

**We now have . . .**

**Computerware** Doodle Bug \$24.95 and Rail Runner \$21.95  
 \*Donkey King 32K \$24.95 and Master Control II \$22.95  
 Also . . . \*Flight Simulator E/B ~~\$19.95~~ \$16.95

\*Also available on disk (32K) at extra charge  
 All programs 16K on cassette unless otherwise stated  
 Send for our free complete catalog and descriptions!  
 WE pay postage, YOU save money! (in the U.S. and Canada)  
 TN residents add 6.25% sales tax, C.O.D. orders add \$1.00



(615) 875-9656  
 P.O. Box 15892  
 Chattanooga, Tn 37415





### PRETTY PRINTER

This M/L utility program will allow you to write your code in as compact a form as you wish, but list it to the screen or printer in an easy to read 'PRETTY PRINT' format. Turn this: -

```
10 PRINT "EXAMPLE"; FORX=ATO M:FORY=STO  
P:Z=X + Y:PRINTZ:NEXTY:NEXTX
```

```
Into this: - 10 PRINT "EXAMPLE":  
FOR X = A TO M:  
FOR Y = S TO P:  
Z = X + Y:  
PRINT Z:  
NEXT Y:  
NEXT X
```

With one simple command.

CAT. NO. OM001 16K Ext \$12.95

### P.U.F.F.

Say the magic word and P.U.F.F. your print formatting problems disappear. The Printer Utility File Formatter turns any word Processor (that produces ASCII text files) into a super printer formatter. Embedded codes will perform the following functions: -

- \* Send control codes to your printer.
- \* Set left and right margins at any time.
- \* Set headers and footers.
- \* Left, Right and Fill Justify.
- \* Centre the next 'n' lines.
- \* Temporary indent (neg or pos).

Plus many other features.

CAT. NO. OM002 16K Ext \$24.95

### CONVERT

Have you ever wondered how many cubits there are in a furlong? With this program you can convert units of length, volume, area or weight from or to the equivalent Imperial, Metric, Nautical or Historical systems of measurement.

CAT. NO. OM006 16K Ext \$9.95

### DATAMAIL

The ultimate cassette based mailing list program for home or business use. Fully customized data collection screen allows you to set your own field lengths and field titles. Fast machine language sort by any column in any field. Save all or any block of files for latter reading by DATAMAIL or your own letter program. Merge two or more lists, search by record number or key word in any column. One key commands for Input, Kill, Change. Print single records or any block of files, 1, 2, 3 or 4 across. 32K holds about 300 files.

CAT. NO. DM003 16K Ext \$14.95

### FIRST SAMPLER

Six programs for the price of one. All have been published in popular computer magazines and are now available on one tape at this special price.

- \* MATH Improve your mental math skills
- \* WORD Make words from the supplied letters in this game for the whole family.
- \* CONVOY Can you sink the computers convoy before it sinks yours?
- \* BAGIT Train your memory to remember the things you put in the bag.
- \* VECTORS Row your boat across the river without going over the falls.
- \* AHHA Find the treasure chest in Another Haunted House adventure. Don't get caught by the Old Miser's ghost.

CAT. NO. DM005 16K Ext \$9.95

### COCOCOPY

This all M/L Program will copy BASIC or M/L programs including most Auto Start Programs. It will supply the beginning, ending and offset addresses and allow you to change the load address for M/L programs. I/O errors are ignored so that bad tapes can be corrected. Programs can be renamed and the motor/audio functions are controlled from the keyboard.

CAT. NO. DM004 16K Ext \$12.95

**SEND \$2.00 FOR OUR 25 PAGE CATALOGUE**

**Refunded with first order**

**We are dealers for the following fine companies: -**

- ARK ROYAL GAMES
- COMPUTER ISLAND
- D S L COMPUTER PRODUCTS
- DYNAMIC ELECTRONICS
- FRANK HOGG LABORATORIES
- HOMEBASE COMPUTER SYSTEMS
- HOME RUN COMPUTER PRODUCTS
- LITTLE BITS COMPUTING SERVICES
- MARK DATA PRODUCTS
- NELSON SOFTWARE SYSTEMS
- RAINBOW CONNECTION SOFTWARE
- SPEECH SYSTEMS
- SUGAR SOFTWARE
- THE PROGRAMMERS GUILD
- TOM MIX SOFTWARE
- WEST BAY COMPANY

**BOOKS from  
SYBEX \* BYTE \* OSBORNE**

**THE  
DATAMAN**

Box 431, Sta. B  
Hamilton, Ontario  
Canada L8L 7W2  
1-416-529-1319

**ALL PRICES  
IN CANADIAN  
DOLLARS**

CLS(1) = \$8F, CLS(2) = \$9F, CLS(3) = \$AF, CLS(4) = \$BF, CLS(5) = \$CF, CLS(6) = \$DF, CLS(7) = \$EF, CLS(8) = \$FF.

Except for CLS(0) all the graphic blocks are separated by \$7F. But the values from one to eight will be too small; we need values ranging from \$10 to \$80, to make this work. What we have to do is shift the values four places, which will effectively multiply the values within by \$10. Okay, I think we're ready to program. In Listing 2, you will have the program which will operate the same as the BASIC program in Listing 1.

**Listing 2:**

```

0E00          00100      ORG      $E00
0E00 BD      A92B      00110  START  JSR      $A92B
0E03 BD      A1C1      00120  WAIT   JSR      $A1C1
0E06 27      FB        00130      BEQ      WAIT
0E08 B1      31        00140      CMP#A   ##31
0E0A 25      10        00150      BLO     ZERO
0E0C B1      3B        00160      CMP#A   ##3B
0E0E 2E      0C        00170      BGT     ZERO
0E10 80      30        00180      SUB#A   ##30
0E12 48          00190      LSL#A
0E13 48          00200      LSL#A
0E14 48          00210      LSL#A
0E15 48          00220      LSL#A
0E16 8B      7F        00230      ADD#A   ##7F
0E18 1F      B9        00240      TFR     A,B
0E1A 20      02        00250      BRA     CLS
0E1C C6      B0        00260  ZERO  LDB     ##80
0E1E BD      A92A      00270  CLS   JSR      $A92A
0E21 20      E0        00280      BRA     WAIT
          0E00      00290      END     START

```

Software Review . . .

## 64K Hits The Market With This Word Pro 'Plus'

To sum a review in one sentence, it appears that the CoCo has finally come of age. The *64K Screen Expander* by Computerware is a cassette based program that requires a 64K color computer with Extended BASIC. A *CLOADM* command followed by an *EXEC* gives you a full 51 characters across, 24 lines, upper and lower case screen. The program to enable the 64K option is built-in and is automatic. What if you hit the reset button? No sweat. The program is protected against reset. It works too! What about the *PRINT@* statement? No problem.

Actually the 51 x 24 screen is only part of the package. Another program supplied is a "Character Set Editor" on the reverse side of the tape. Written in BASIC the "CHRGEN" gives you the opportunity to design your own custom character sets. After a *CLOAD* and *RUN* you are treated to the entire character set on the top half of the screen. The bottom half of the screen has a menu of commands and a 5 x 8 array of dots. After selecting the character you wish to alter you can either use the joystick or arrow keys/spacebar to design your own. After each character, you have the choice of whether to quit or continue, or save the set to either tape or disk. The custom character set then may be used at any time by a *CLOAD* command after running the *Screen Expander*.

Now, back to the main package. Even though it is not specified, the program resides in high (\$F800) memory. I think it would have been nice of the authors to tell us exactly where so as to prevent any wipeouts, even though it's pretty unlikely at that location. Also, no mention is made of whether the program is relocatable. At the same time, user options are as follows:

- HI-RES SWITCH — Regular or hi-res screen.
- DISPLAY MODE — Normal or inverted characters.
- PRINT@MODE — Modify syntax of PRINT@ statement.
- CHARACTER SET POINTER — Start of lookup table.
- COPY TEXT TO GRAPHIC — Copy the hi-res text screen to the current graphics page.
- COPY GRAPHIC TO TEXT - Copy current graphic pages to hi res text screen.

SETUP PAGE 0 AS PMODE 4 — Simulate PMODE 4, 0

The last three subroutines allow the combination of graphics and text on a high resolution screen.

In summary, I recommend this program to anyone as an excellent utility for whatever use you have in mind. The program seems to be problem free and immune to my standard accidental "wipeout" procedures. To move the program to disk, you may try a *SAVEM*"R64K51C",&H4000,&H48FF,&H4000. It seems to work just fine.

(Computerware, P.O. Box 68, Encinitas, CA 92024, \$24.95 tape, \$29.95 disk)

—Dan Downard

### MORETON BAY SOFTWARE For TRS 80 Color Computer & TDP 100

#### PROGRAMERS TOOLKIT

6 USEFUL TOOLS FOR THE SERIOUS COMPUTER USER

**CHAINRUN** - Add a single line to a Basic program and subsequent Basic programs load and run automatically. Allows program chaining.

**HEXEDIT** - ML program which gives full screen edit capability in Hexadecimal or ASCII for any RAM address in memory. Can be used to patch ML routines in memory.

**DUMP** - Displays the memory contents of ML programs.

**CMERGE** - ML subroutine which saves the trouble of retyping long subroutines. Merge different Basic programs into one large program.

**CROSS REFERENCE** - ML program which prints line location of all variables and sorted cross reference list for the source and destination for every GOSUB and GOTO statement in a Basic program.

**BASIC FULL SCREEN EDIT** - ML program which will give full screen edit capability for any Basic program. Edit programs with cursor control.

16K \$28.95 postage paid  
includes 10 pages of Documentation.



TRS 80 © Tandy Corp.

**MORETON BAY SOFTWARE**  
A DIVISION OF MORETON BAY LABORATORY

316 Castillo Street  
Santa Barbara, CA 93101  
(805) 962-3127

California residents add 6% sales tax.

**NEW** for the Color Computer TRS-80  
**'COCOCASSETTE' SUBSCRIPTION SOFTWARE**

\* TRS-80 IS A TRADEMARK OF TANDY COMPANY



**ENJOY A MONTHLY COLLECTION OF 8-10 PROGRAMS!**  
 Including games, education, home finance and more;  
 on cassette for as low as **\$5.00** a month! Add some ac-  
 tion and imagination to your Color Computer. . . Best of  
 all, we do the work!

**LOOK AT SOME OF THE LETTERS WE RECEIVED FROM OUR SUBSCRIBERS.**

"I just thought I'd let you know that your cassettes arrive in good order, load just fine, and I really enjoy your programs!"  
 MARION, OHIO

"I was extremely impressed by the first tape I received from you. The added extras are just super."  
 WILLOW GROVE, PENNSYLVANIA

"Seldom do I ever write a fan letter. Usually if something is good, nothing is ever said. I just renew the subscription or buy the product instead. T&D is an exception. I subscribe to several cassette computer magazines. Yours is certainly the most creative. The covers are original and clever. The material covered is excellent!"  
 PINE BLUFF, ARKANSAS

"I only entered a six-month trial but am already willing to extend my subscription!"  
 COLTEWAH, TENNESSEE

**PRICES**

1 YR (12 ISSUES) . .	\$55.00
6 MO (6 ISSUES) . .	\$30.00
SINGLE COPIES . .	\$ 6.00

—MICHIGAN RESIDENTS: ADD 4% TO ORDER

—OVERSEAS ADD \$10.00 TO SUBSCRIPTION AND \$1.00 TO SINGLE COPIES

**616 396-7577**

PROGRAMS ARE FOR  
 EXTENDED BASIC  
 MODEL ONLY. ISSUES  
 ARE SENT FIRST CLASS.



**SUBSCRIPTION SOFTWARE**



**IMMEDIATE SHIPMENT!**  
**PERSONAL CHECKS WELCOMED!**  
**SEND CHECK OR MONEY ORDER TO:**



**T & D SOFTWARE P.O. BOX 256-C • HOLLAND, MICH 49423**



## UTILITIES AND GAMES FOR THE COLOR COMPUTER

- BACKUP** ----- \$ 9.95  
Speed up disk backups, helps to recover crashed disks. Bypass I/O errors and fix many disk problems.
- CATALOG** ----- \$ 9.95  
An automatic disk file cataloging system. File the directories of your disks.
- COPYTAPE** ----- \$ 9.95  
Copy, merge, and backup your tape based software. Works even with most popular pre-loader tapes.
- CZAP** ----- \$ 9.95  
A disk inspect and modify routine. Learn how disks work, fix problems on your disks.
- CCRPM** ----- \$12.95  
A disk drive speed checking routine. Displays on your screen the current, average, high, and low speeds of your drive. Complete with instructions for correcting the speed of your disk drive.
- NEATDIR** ----- \$ 6.95  
Places the file names of your disk directory into alphabetical order. Makes finding programs on your disks easy. Keeps your disks in order.
- OFFLOAD** ----- \$ 9.95  
Create tape backups of your disks. A disk to tape, tape to disk backup system.
- ONERR** ----- \$12.95  
An error handler for BASIC programs. Allows your program to receive control whenever any error occurs. Take control and fix your problems.
- TAPEDIR** ----- \$ 9.95  
Create a directory of your tapes. Lists program name, length of program, start, end, and transfer addresses for all programs on your tapes.
- TAPELIB** ----- \$12.95  
A BASIC tape subroutine append routine and a starter library of 5 subroutines. Create you own subroutine library on tape to append to your programs.
- TAPEXFER** ----- \$ 9.95  
Load your tape programs to disk automatically. Great for Chromasette subscribers, automatically loads an entire issue to disk.
- TREKBOC** ----- \$14.95  
The classic Star Trek computer game. A real time game with moving Klingons and action graphics.

Please add \$1.00 shipping and handling on all orders. Pa. residents add 6% sales tax. Canada orders must be paid in American funds. No COD or charge cards, send check or money order only to:

A. M. HEARN SOFTWARE  
602 S. 48th Street  
Philadelphia, Pa. 19143

Write for a free catalog of these and other products. Dealer inquiries invited.

## Protectors Called Outstanding Arcade Game

Video games are really hot these days. To get a shot at your favorite game, you will normally have to wait your turn in the arcade, and as soon as you are killed, it costs you another quarter to play again. With the difficulty and complexity of today's games, you can very quickly spend your entire allowance for the week in a matter of minutes. Fortunately, our CoCo is, among other things, a great game playing machine, and the major software firms have seen fit to translate our favorite games into a language that CoCo can understand.

*Protectors* is a 32K machine language game which is patterned after the popular *Defender*. For those of you who are not familiar with the game, the object is to defend your city from the waves of enemy fighters who are constantly dropping bombs on it. In order to do this, you must zap the enemy fighters with your laser cannon before they drop their bombs. If you can't manage to do that, you can still zap the bombs before they hit your city. Of course, the enemy fighter planes are not your only problem. There are heat seeking mines, a mother ship that zeros in on you, and a sort of mini-ship that you can barely see but you can hear. You also have four "smart" bombs per ship and there are three skill levels that you can choose from. There is also a pause feature, and you get a new ship with each 5,000 points.

After you load the program and *EXEC* it, one of your ships appears in the upper left hand corner of the screen, and begins firing to the right and moving down. As it does, the title screen begins to appear. After you select the skill level you want, the action begins.

At first, the action is slow and there are not too many enemy fighters or heat-seeking mines. As you complete each "attack wave," the action speeds up and there are more enemy fighters to contend with. At the same time, the heat seeking mines become more difficult to avoid, and the mini-ships and mother ship begin to harass you. At about attack wave 10, the screen is really becoming full, and some of the enemy fighters are turning into kamikaze fighters. Around attack wave 15, it is almost impossible to stay alive. There are enemy fighters, heat seeking mines, and the like all over the place, and everything is moving about with amazing speed. Eventually, you are killed off, and you get the chance to give your joystick button and your fingers a well deserved rest. So far, my best score is just under 95,000, and believe me, you will need a rest after scoring that many points.

*Protectors* has outstanding graphics and sounds, and the attention to detail is truly amazing. One of the things I liked most about it, though, was that I was able to out-score my brother, Steve, who can regularly double or triple my best scores on all the other games that we have played. *Protectors* is one of the finest games that I have ever seen, and it is a must for all of you arcade game fans out there. Even if you don't like games, you should buy it just to see what CoCo is capable of doing in the hands of a master programmer.

(Tom Mix Software, 3424 College N.E., Grand Rapids, MI 49505, \$24.95 tape, \$27.95 disk)

—Gerry Schechter

# Superior Graphic Software Products

HOME OF MOTION PICTURE PROGRAMMING

NATIONALLY ACCLAIMED PROGRAMS FOR THE

**TRS-80<sup>®</sup> COLOR COMPUTER<sup>®</sup>**



## TALKING GRAPHIC DEMONSTRATION

When someone sees your CoCo and asks "Just what does this thing do?" then load TALKING GRAPHIC DEMO and let your computer do its own show and tell, complete with musical background and a running commentary. As quoted in THE RAINBOW: "This is, frankly, better than anything the people who sell the machines have."

Extended color basic. Tape only ..... \$24.95

## THE DISK DOCTOR

DISK DOCTOR.....That disk with the vital information you forgot to back up just crashed! Don't PANIC. Take 2 aspirin, count to 10, and put in an emergency call for THE DISK DOCTOR. This program will salvage machine language, BASIC, data, ASCII, even MPP pictures. Completely menu driven for easy use. As 80 MICRO REVIEWER states "I feel safer when creating important files and programs having the DOCTOR 'on call!'"

DOS only ..... \$49.95

## MPP-TUTORIAL

MPP-TUTORIAL.....The programming tool of the professionals. You may not be a great artist, but you too can produce stunning, high resolution graphics. Detailed step by step instructions to create near studio quality animation. Quote CHROMASETTE: "...if you want to see and use the full graphic potential for your CoCo, this program is required!"

Extended color basic - specify tape or disk .....

## EL CASINO

EL CASINO....Three startling, action-packed high resolution graphic games, ideal for den and rumpus room parties. Games are programed with MPP graphics, and each is over 14k long.

### DICE GAME..

..This is the only craps game on the market that allows 4 players to make any or all of 12 field bets before every roll. The graphic banker automatically tracks and displays bets as they are made. True Casino action on your CoCo.

### BLACK JACK..

..The famous card counter not only shows the cards remaining in the deck, but computes the odds on hitting your hand with the cards remaining. Las Vegas rules apply. super sound effects.

### SLOT MACHINE..

..Looks and sounds like a Casino machine.

(if any) hits the tray with a nice "clunk". Adjustable odds...make it easy on yourself if you like.

Extended color basic. Specify tape or disk .....

POSTAGE PAID

P.O. BOX 451 CANTON, NC 28716.  
For Fast Service Call 704/648-6015



\*TRS-80 Trademark Tandy Corp.

## Paint An ASCII Border 'Round The Ol' CoCo

By Ray Gauvreau



Have you got the green screen blues? Want to liven up your title pages? Impress your friends? The following is a short program designed to place a character border around the alphanumeric display screen. This position independent code is very short and very fast and will 'paint' the edges with any printable ASCII character, either graphic or alphanumeric, reverse field or normal.

The routine can be created by running the BASIC program which *POKES* the routine into high memory. Once created, the code can be saved by typing in *CSAVEM*"BORDER",16352,16380,16352. You can append the BASIC lines 10 through 70 to your own basic programs. Once in memory the routine is called by the basic command *X=USR0(Y)*. In this form X can be any value because it is not used, and Y is set to the ASCII value of the character you wish to frame with.

I'll explain some of the BASIC program. Line 10 clears some string space and then protects high memory beginning at 16325. This is where the code is to begin. Line 20 reads the values stored in the *DATA* statements 50 to 70 and *POKES* these values one at a time into memory. Line 30 tells the computer where to go when it encounters the *USR0* command, such as the one used on line 160. The rest of this program sets up and calls the routine. First you are asked to *INPUT* a number, then this is checked to see if it is greater than 32767 as this is the largest value the routine can handle. Lines 120 and 140 each call the subroutine with a different value inside the brackets. The *USR0* values don't always correspond to the ASCII you would expect. Play with it.

### The listing:

```

10 CLEAR200,16352
20 FOR R=16352 TO 16380:READ P:P
OKE R,P:NEXT R
30 DEFUSR0=16352
40 'THESE DATA STATEMENTS HOLD
    THE MACHINE LANGUAGE ROUTINE
50 DATA 189, 179, 237, 31, 152,
142, 4, 0, 16, 142
60 DATA 4, 31, 237, 137, 1, 224,
237, 164, 49, 168
70 DATA 32, 237, 129, 140, 4, 32
, 38, 240, 57
80 'TO SAVE THE ROUTINE TYPE
CSAVEM"BORDER",16352,16380,16352
90 'THE REST OF THIS PROGRAM IS
    DEMONSTRATION
100 CLS : INPUT "INPUT THE ASCII
NUMBER FOR THE BORDER YOU WANT
";BN
110 IF BN>32767 THEN GOTO 100CLS
120 CLS RND(8) :X=USR0(BN)
130 PRINT@168,"IT'S SHOW TIME";
140 X=USR0(BN)
150 FOR R=1 TO I:NEXT
160 X=USR0(BN-3)
170 FOR T=1 TO I:NEXT
180 IF I>1 THEN I=I-1 ELSE I=50
190 IF INKEY$=""THEN140
200 GOTO 100
    
```

## PAY WHAT YOU WANT

for home and business software  
RS CoCo and TDP-100

16/32K Disk or Cassette  
Extended Color Basic Required

### BUDGET RECORD

Income & outlay by 99 categories. Great for taxes. 32k.

### MAILING LIST

Makes labels, printouts and alphabetized lists. M/L sort.

### APPOINTMENT BOOK

Print a calendar with any number of memos/day. (32k. Requires printer with compressed characters)

### GRADE BOOK

Make rolls & grade sheets, complete with stats and totals.

### ALSO AVAILABLE

Phone Book, Sales Record, Car Repairs, Diet Delight, Grocery List.

### The Fine Print:

Order two programs maximum. Send shipping/handling in advance (1—\$4.00; 2—\$6.00). After using the program, pay only what the program is worth to you. Let's try applying right livelihood to the software industry!

Specify 16/32K and type of printer.

Bruck Associates  
6609 Westmoreland Ave.  
Takoma Park, MD 20912  
(301) 270-5822



Free catalogue on request



## Kzirgla Has Good Graphics, Sound, But Lacks Diversity

Adventure games are the best thing for microcomputers since *Space Invaders*. They require skill, luck, curiosity, and patience. I have played enough Adventures to know that skill and curiosity are a necessity. On the whole I play text Adventures. But it is my real dream to play graphics Adventures with hundreds of rooms and zillions of treasures. Well, if you are thinking of buying *Conquest of Kzirgla* for treasure hunting you can forget that idea right now!

*Conquest of Kzirgla* is a 16K Adventure game made by Rainbow Connection Software. You load the game by doing a *CLOADM*; then, suddenly, a graphics display materializes while the game is loading. That is very impressive. Once loaded, it asks you if the hit point values and strength values are to your liking. Usually they are, but it is better to have high hit points, in my opinion. Throughout the game the text words are expressed in an ersatz Old English. That is a nice touch!

After you answer "yes" or "no," you enter the high resolution graphics screen. Here you see a maze being drawn remarkably fast. I was extremely impressed by the way the mazes were constructed and drawn. When the entire maze is drawn, two little figures are put on the screen: your character and the wizard. By the way, your goal is to destroy this wizard by any means possible. Unfortunately, if you get too close to him in the beginning it is automatic suicide! Not only do you have to kill *him*, but you have to do battle with his henchmen.

There are six creatures who have only one goal in mind. That goal is to destroy you in any way possible. The creatures' names are very unusual. The six names are Cellapod, Centapor, Mantoid, Jartrex, Cadaver and Tantrite. Each monster has its own strengths and weaknesses. As you go deeper into the mazes more creatures appear. I have made it all the way into level 10 and have seen the next to last creature, Cadaver.

The nice thing about this game is that your character moves very fast and has a nice shape. Some games make your character look like a dot or a square. You are capable of firing fireballs or deathrays. Also, you obtain weapons such as clubs and daggers as the game goes on. The only catch is that for every fireball, deathray or shield used, you use so much energy. The numbers and letters at the bottom of the screen flow very smoothly and have a nice look about them.

The instruction manual that comes with the game is very informative. It explains your goal and describes the monsters. I would hate to meet any of them in a dark alley! (Or *anywhere* besides my CoCo screen, for that matter.) Also, it gives you a list of commands and what they do.

This is a well-constructed Adventure game, but I must say this: though at first, the adventure is fun and interesting, it soon becomes monotonous. All you do is kill. There are no treasures to find or special spells to cast. By the time I got to level 10, the boredom had overtaken me.

The next time Rainbow Connection Software makes a maze Adventure they should think about putting treasures and spells in the game. Also, it would have been nice if they had a game save feature in the program. If you are interested in purchasing a game for great graphics and fantastic sound, this is the game for you. On the other hand, if you want to buy a game to search for treasures and use your mind this is not the one.

(Rainbow Connection Software, 3514 6th Place N.W., Rochester, MN 55901, \$21.95 cassette, \$26.95 disk)

—Ken Ostrer

### MASTER DIRECTORY

Put order in your life! Have your diskettes multiplied and now are out of control? MASTER DIRECTORY will sort out your problems and locate all of your programs. Only takes seconds to add all of the files on one diskette to the master directory.

- ‡ Master listing by diskette number with description.
- ‡ Master listing of all your programs in either diskette sequence or program sequence.
- ‡ Basic for easy customizing: fast mach lang sort
- ‡ Requires 32k with printer
- ‡ Only \$20

Other COCOPRO products: (All machine language)

FULL SCREEN EDITOR ----- \$15  
Adds arrow-key control for editing of basic programs.

REVERSI ----- \$9  
"Othello"

EXPANDED DIRECTORY ----- \$15  
Saves 120 files on one diskette.

COLOR DIRECTORY ----- \$12  
Fantastic DIR!

COCOSLOTS ----- \$9  
Las Vegas at home.

CASSETTE DIRECTORY  
List program name, length of basic program or start, end and transfer addresses for mach lang program. FREE with all orders if requested or send \$2.50 for program on cassette.

>> FREE CATALOG <<  
Send \$45E

Send check or money-order to:

COCOPRO  
P.O. BOX 37022  
ST LOUIS, MO 63141



Postage paid on all pre-paid orders in continental U.S.  
MO residents include 5.625% sales tax.

# NOW, LET'S MAKE SOME REGULAR POLYGONS!

By Don Inman

*Rainbow* Contributing Editor

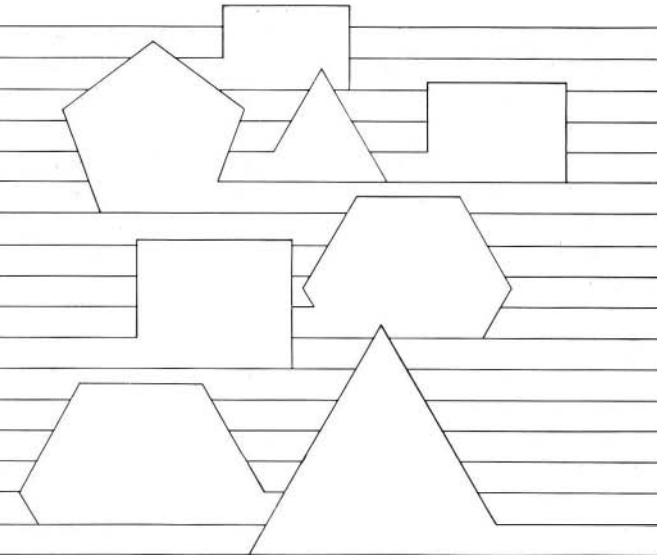

This is the seventh of a series of articles on the graphic capabilities of Extended Color BASIC on the TRS-80 Color Computer. It goes beyond the material that was covered in the book *TRS-80 Color Computer Graphics*. The material is copyrighted by Don Inman.

"A polygon is a plane figure consisting of  $n$  points,  $p_1, p_2, p_3, \dots, p_n$ , called vertices, and of  $n$  line segments  $p_1p_2, p_2p_3, \dots, p_{n-1}p_n, p_n p_1$  called sides. A polygon of three sides is a triangle; of four sides is a quadrilateral, or five sides is a pentagon, . . . . , of  $n$  sides is an  $n$ -gon." (From *Mathematics Dictionary* by James and James; D. Van Nostrand Company, Inc.)

In this article, we will restrict our discussion to regular polygons. A polygon is regular if its sides are equal and its interior angles are equal.

Examples:

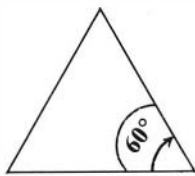

Triangle  
 $n = 3$

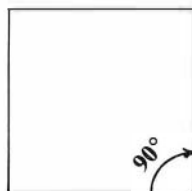

Quadrilateral  
 $n = 4$

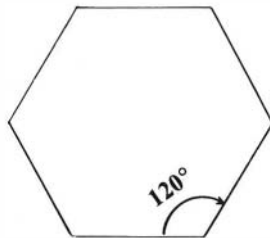

Hexagon  
 $n = 6$

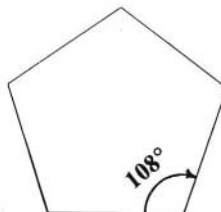

Pentagon  
 $n = 5$

In last month's article, a general program was developed which drew a rectangle when given its height ( $H$ ), and width ( $W$ ) and the coordinates of one vertex (corner),  $X_0, Y_0$ . It was discovered that the rectangle could be rotated by using

the sine and cosine functions to draw the lines at an angle to the horizontal or vertical axes.

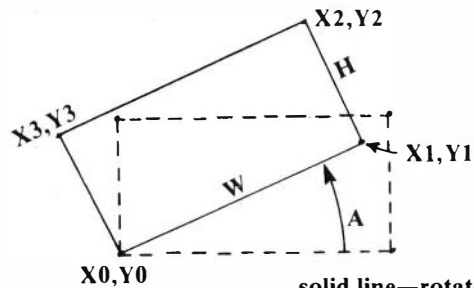

**solid line—rotated rectangle**  
**dotted line—original rectangle**

- 1)  $X_1 = X_0 + \text{COS}(A) * L$   
 $Y_1 = Y_0 - \text{SIN}(A) * L$
- 2)  $X_2 = X_1 - \text{SIN}(A) * H$   
 $Y_2 = Y_1 - \text{COS}(A) * H$
- 3)  $X_3 = X_2 - \text{COS}(A) * L$   
 $Y_3 = Y_2 + \text{SIN}(A) * L$

Since all sides of a regular polygon are equal, it would seem that a similar, but simpler, technique could be developed for regular polygons. Let's first examine a specific case, the regular pentagon.

Starting at the lower left corner  $X_0, Y_0$ , draw a line of length  $L$  with no rotation ( $A = 0$ ) to the point  $X_1, Y_1$ .

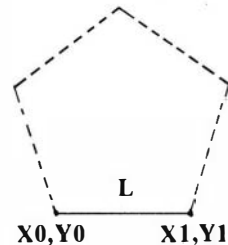

It is clear that  $X_1 = X_0 + L$  and  $Y_1 = Y_0$ . But, since the cosine of zero degrees equals 1 and the sine of zero degrees equals 0,

the relationships could have been stated as:

$$X1 = X0 + \text{COS}(0) * L \text{ and } Y1 = Y0 + \text{SIN}(0) * L$$

Next, consider the angle A between the extended line from X0,Y0 through X1,Y1 and the line segment from X1,Y1 to X2,Y2.

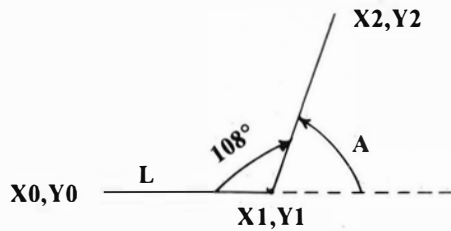

$$\text{Angle } A = 180 - 108 = 72 \text{ degrees}$$

Angle A, as shown in the diagram is called an external angle. From what was learned about rotated rectangles last month, the coordinates of X2,Y2 can be stated as:

$$X2 = X1 + \text{COS}(72) * L \text{ and } Y2 = Y1 + \text{SIN}(72) * L$$

Turning the next corner through Angle A, we have the line segment from X2,Y2 to X3,Y3. The angle of rotation as measured from the horizontal is now  $A + A = 144$  degrees.

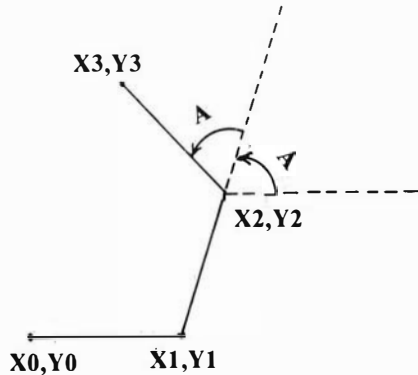

At this point, I would like to make the conjecture that the coordinates for the point X3,Y3 can be stated as:

$$X3 = X2 + \text{COS}(144) * L \text{ and } Y3 = Y2 + \text{SIN}(144) * L$$

Proceeding through point X4,Y4 and back to X0,Y0, this conjecture would lead to general equations for any coordinate pair that describes a vertex of the pentagon.

Given X0,Y0 with  $N > 1$ ,

$$X_n = X_{n-1} + \text{COS}((n-1)*A) * L$$

$$Y_n = Y_{n-1} + \text{SIN}((n-1)*A) * L$$

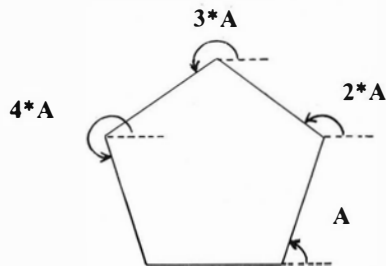

If this is true, a regular pentagon can be drawn by the

computer using a BASIC program with two known variables:

L = length of the equal sides

X0,Y0 = coordinates of one vertex

Now look at the size of the external angles of the following regular polygons.

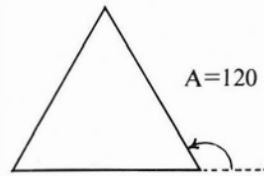

$$n = 3$$

$$n * A = 360$$

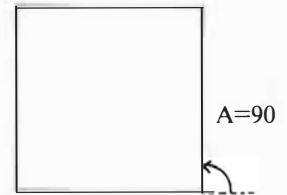

$$n = 4$$

$$n * A = 360$$

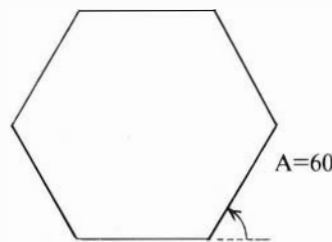

$$n = 6$$

$$n * A = 360$$

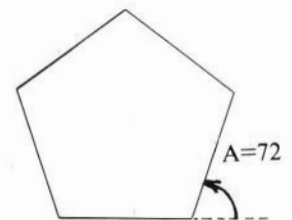

$$n = 5$$

$$n * A = 360$$

## CONVERT YOUR PICTURES INTO HARD COPY

CATCH THAT COLOR PMODE3  
PICTURE ON PAPER (USING

A CGP-115 COLOR PLOTTER)

- Machine language subroutines for speed
- Auto start from cassette
- Works with Micro Painter
- Will print pictures from cassette
- Includes sample picture - American Flag

Just \$14.95 plus \$1.50 postage and handling

To: All-American Ultralight Industries/ (AUI)  
1144 Kingston Ln.  
Ventura, Calif. 93001



It appears that the sum of the external angles of any regular polygon is 360 degrees. Another way to state this is that if you know the number of sides (N) of a regular polygon, an external angle can be found by:

$$A = 360/N$$

If this is true, any regular polygon can be drawn by a computer using a BASIC program with three known variables:

- N = number of sides
- L = length of one side
- X0,Y0 = the coordinates of one vertex

Keeping in mind that the angles for trigonometric functions must be stated in radians for the BASIC program and that  $2\pi$  radians = 360 degrees, a single FOR-NEXT loop can be set up to do all the work.

First define some variables:

- N = number of sides
- A = angle in radians
- S =  $2\pi/N$  the step for the loop
- P =  $2\pi - S$  the exit limit of the loop

With X1 = X0 and Y1 = Y0 as the loop is entered, the FOR-NEXT loop becomes:

```
FOR A = 0 TO P STEP S
  X2 = X1 + COS(A) * L
  Y2 = Y1 - SIN(A) * L * .8
  LINE(X1,Y1)-(X2,Y2),PSET
  X1 = X2: Y1 = Y2
NEXT A
```

negative to convert display to Cartesian coordinates

adjustment for screen distortion

end point of one line becomes start of next

The following program was written so that the pentagon drawing portion is a subroutine. In this way, it can be added to any program that you wish. The main program is written in three function modules.

### 1. Input

This module clears the text screen and then requests the inputs N, L, and X0,Y0 in succession.

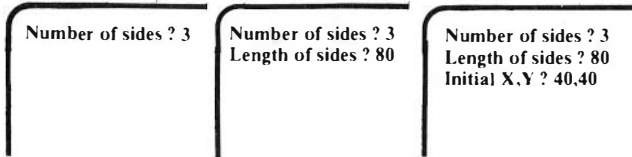

### 2. Screen Set-up

This module sets the graphics screen to two-color, high resolution and sets the colors to provide black lines on a green background.

### 3. Program Control

This module inverts the Y axis so that the first quadrant of the Cartesian Coordinate System is displayed. It also allows for a correction factor of 0.8 to the Y axis. The drawing subroutine is called, and upon return, INKEY\$ is used to hold the graphics screen until a key is pressed. At that point, a return is made to the first module.

The subroutine uses the FOR-NEXT loop, described previously, to draw the desired polygon.

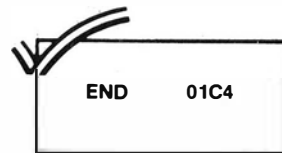

### Listing for Regular Polygons

```
100 REM *** INPUT ***
110 CLS
120 INPUT"NUMBER OF SIDES";N
130 INPUT"LENGTH OF SIDES";L
140 INPUT"INITIAL X,Y";X1,Y1
150 '
200 REM *** SCREEN SET UP ***
210 PMODE 4,1
220 PCLS1
230 COLOR 0,1
240 SCREEN 1,0
250 '
300 REM *** PROGRAM CONTROL ***
310 Y1=181-.8*Y1
320 GOSUB 5000
330 IF INKEY$="" THEN 330 ELSE 1
10
340 END
350 '
5000 REM *** POLYDRAWSUB ***
5010 S=6.2832/N
5020 P=6.2832-S+.01
5030 FOR A = 0 TO P STEP S
5040 X2=X1+COS(A)*L
5050 Y2=Y1-SIN(A)*.8*L
5060 LINE(X1,Y1)-(X2,Y2),PSET
5070 X1=X2: Y1=Y2
5080 NEXT A
5090 RETURN
```

## "I CAN TALK!" TALK PROCESSOR

Quick and easy to use. No programming required. Has 26 common words. Just type in 2-letter codes and make hundreds of statements in 3 voices. Uses digitally recorded human speech. "Extremely clear". *Rated good - Rainbow Nov. 82* 16K Ext. Basic \$14.95

### "ADD-A-VOICE" - to your own Basic programs.

A machine language utility (uses 4K). Generate digitized human speech with just a few simple Basic commands. GAME SET (I, WIN, GOT, YOU, etc.) and QUIZ SET (YES, NO, RIGHT, GOOD, etc.). You get both sets - 25 words total. Specify 16K or 32K. Needs no Ext. Basic. \$14.95

### SUB-MISSION - HI-RES COLOR ACTION GAME

for 16K Ext. Basic. *BONUS:* Order Sub-Mission and get "Missle Attack Underground" game FREE.

JOYSTICK REQUIRED \$12.95

For immediate shipment send certified check or money order. Personal check orders shipped in 2 weeks. Send to H.I.B., 3505 Hutch Place, Chevy Chase, MD 20851. Phone 301 656-1825 after 6 p.m. Add \$1.00 for shipping.



**H.I.B. SOFTWARE**  
FOR THE TRS 80 COLOR COMPUTER



by *Elite*

*Fly your spaceship through enemy Starbases. Avoid guided missiles, lasers, and firing turrets! Can you reach their leader... ZAKSUND?*

★ 3-D ★  
**COLOR GRAPHICS**

... the creators of  
 - Intergalactic Force<sup>1</sup>  
 - War Kings<sup>2</sup>  
 - Party Pak<sup>1</sup>  
 - Trek-16<sup>2</sup>  
 - many other fine programs!

1. ANTECO  
 2. TOM MIX



*Elite Software*

Box 11224  
 Pittsburgh, PA 15238  
 (412) 795-8492



**\$24.95 Casette**  
**\$27.95 Disk**

Add \$1 Postage and Handling  
 PA residents add 6% sales tax

EXCITING  
 ★  
 ARCADE ACTION  
 32K  
 MACHINE LANGUAGE

**Screen Displays**

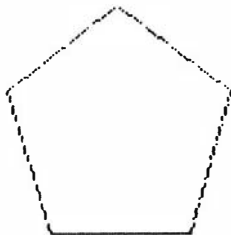
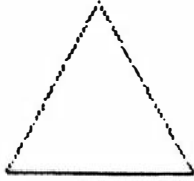

**Inputs**

N = 3  
L = 80  
X,Y = 40,40

N = 4  
L = 80  
X,Y = 40,40

N = 5  
L = 60  
X,Y = 60,40

**Inputs**

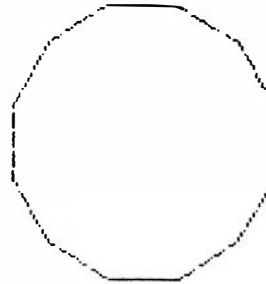
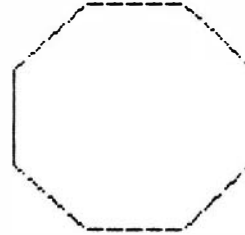
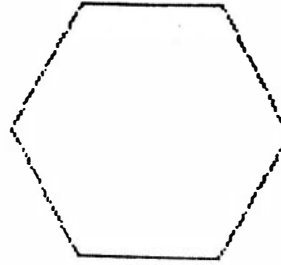

N = 6  
L = 60  
X,Y = 60,40

N = 8  
L = 40  
X,Y = 80,40

N = 12  
L = 30  
X,Y = 80,40

**PEACOCK ENTERPRISES**

WE'RE PROUD

CMAILIST IS A GREAT ADVENTURE -  
BUT NOT AN ADVENTURE GAME!

An Address Book, Phone Book, Mail Label Generator  
and a whole lot more.

CMAILIST is a powerful and professional MINI-DATA-BASE  
for home or office use. CREATE, ADD, DELETE, CHANGE,  
INSPECT, SEARCH, SORT, MAILING LABELS, TICKER FILE,  
and INVOICE all so easily, you'll wonder why you waited so long!

Up to 500 RECORDS containing 10 FIELDS can be stored per file  
(memory and system dependent).

CMAILIST is available in the following versions:

- 4.0 Cassette Systems (specify 16K or 32K) \$19.95
- 5.0 Disk Systems \$24.95
- 5.1 2 Drive Disk Systems with INVOICing \$29.95

CMAILIST includes an easy to follow Comprehensive Manual  
& 1 year warranty.

SO JOIN THE GREATEST ADVENTURE OF ALL-YOU WILL BE A  
WINNER!

C.ITOH ProWriters \$465 Parallel \$565 serial

SEND FOR FREE CATALOG!

Prices Include Shipping! COD Accepted on Software only!  
Send check or money orders to:

PEACOCK ENT.  
194 CANNONGATE III ROAD  
NASHUA, NH 03063  
603-880-8169 Mon-Sat 10-10

Mathematics teachers take great joy in pointing out to their students that a regular polygon approaches a circle as the number of sides increase and the length of the sides decrease. The Regular Polygon program can be used to demonstrate that fact. However, by making a few changes, you can put polygons alongside each other that differ in just that way. The program will automatically increase the number of sides and decrease their length as each successive polygon is drawn.

These changes will do the job:

1. Delete lines 120, 130, and 140
2. Add these lines:  
250 for N = 3 TO 15 STEP 3  
260 X1 = 18\*N-54: Y1 = 80  
270 L=120/N
3. Replace lines 330 and 340 with:  
330 FOR W = 1 TO 200: NEXT W  
340 NEXT N
4. Add:  
350 IF INKEY\$ = " " THEN 350 ELSE 110  
360 END  
370

The complete listing follows with a sample screen display of its execution.

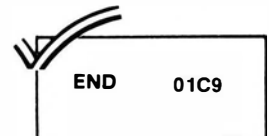

**Listing for Manypol**

```
100 REM *** INPUT ***
110 CLS
150 '
200 REM *** SCREEN SET UP ***
```



```

210 PMODE 4,1
220 PCLS1
230 COLOR 0,1
240 SCREEN 1,0
250 FOR N=3 TO 15 STEP3
260 X1=18*N-54: Y1=80
270 L=120/N
280 '
300 REM *** PROGRAM CONTROL ***
310 Y1=181-.8*Y1
320 GOSUB 5000
330 FOR W=1 TO 200: NEXT W
340 NEXT N
350 IF INKEY$="" THEN 350 ELSE11

```

```

0
360 END
370 '
5000 REM *** POLYDRAWSUB ***
5010 S=6.2832/N
5020 P=6.2832-S+.01
5030 FOR A = 0 TO P STEP S
5040 X2=X1+COS(A)*L
5050 Y2=Y1-SIN(A)*.8*L
5060 LINE(X1,Y1)-(X2,Y2),PSET
5070 X1=X2: Y1=Y2
5080 NEXT A
5090 RETURN

```

Screen display for Manypol Program



**TDP ELECTRONICS**

**The System 100 from Tandy.**

10-1000 16K BASIC COLOR COMPUTER \$CALL  
 10-1010 16K BASIC/ EXTENDED BASIC \$CALL

\*\*\* SPECIAL!! 32/64K EXTENDED BASIC \*\*\*

INCLUDES: COGNITEC'S TELEWRITER 64  
 \$449.00 Wordprocessor Program OR  
 TOM MIX'S "DONKEY KING" Game!!!

\*\*\*\*\*  
**TOM MIX \* ANTECO \* DERRINGER  
 MARK DATA \* COLORSOFT \* BOTEK  
 COMPUTERWARE \* BERTAMAX \***  
 EPSON DOT MATRIX PRINTERS and COMPUTERS \*  
 OKIDATA DOT MATRIX PRINTERS \* AMDEK \*  
 TRANSTAR LQ PRINTERS \* BMC \* RCA  
 HAYES MICROCOMPUTER MODEMS \* NEC \*  
 FRANK HOGG LABORATORY \* SIGNALMAN \*  
 SPECTRAL ASSOCIATES \* ECS CABLES \*  
**C.I.TOH PRO-WRITER PRINTERS**

**Emerald Computer Services**  
 4401 219th S.W.  
 Mountlake Terrace, WA 98043

TDP · ATARI · EPSON · MORROW · TIMEX

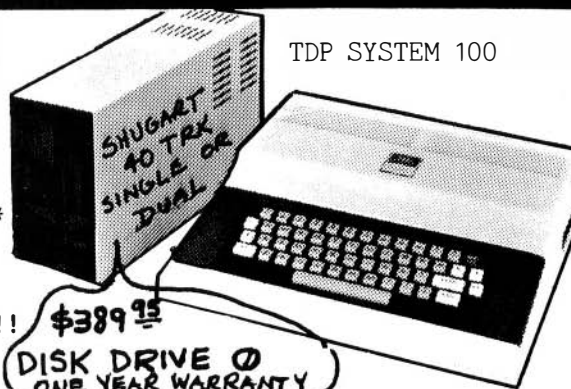

TDP SYSTEM 100

NOTE: TDP-100 System 100  
 PERSONAL COMPUTERS INCLUDE:

- o "BUST OUT" Game Cartridge
- o Two Joysticks
- o Easy to Read Tutorial Manuals
- o TV/ Computer Interface Box
- o RS-232 INTERFACE
- o EXPANSIBILITY

**CUSTOM KEYBOARDS AVAILABLE!**

\* VISA / MASTERCARD ACCEPTED \* COD \*  
 OVERSEAS ORDERS WELCOME!!!  
 ALLOW 2-3 WEEKS for PERSONAL CHECKS!

**206-778-9826**

## Micro-Meltdown A Nuclear Reactor Simulation

By  
Chris Latham  
and  
John Erickson

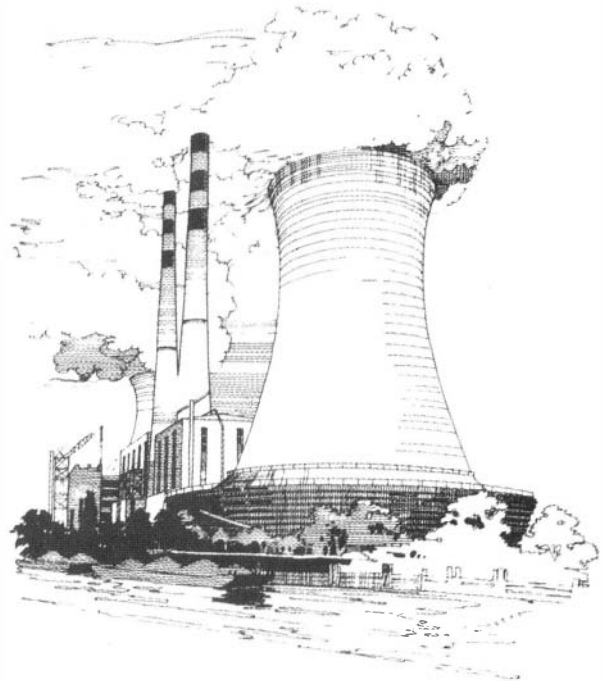

*(Editor's Note: The following article and program, as well as others in this issue, are intended to acquaint Rainbow readers with the concept of computer Simulations. NUKE SIM was especially commissioned by the Rainbow to help kick off our Simulation Contest. In order to ensure that we had a first-rate Simulation to serve as an example, we contacted two top-flight programmers whose accomplishments—Chris Latham, for instance, is the author of Donkey King—are too numerous to be listed here. Their NUKE SIM program, however, is listed here, in its entirety. Is it a good one? Well, here at the Rainbow, we feel like patrons of the arts.)*

The obvious first steps to any project based on practical engineering are toward research. In this case, the local public library provided the texts (listed below) which became the basis for the nuclear reactor simulator program, NUKE SIM.

Another extremely helpful step is the enlistment (or drafting if necessary) of a kindly engineer conversant with the field in question. In this case, engineering advice was provided by Mr. Gary Sandburg; who, when suitably bribed with a cherry walnetto, proved a marvel at digging out his old physics textbooks.

It would seem prudent to seek a general understanding of the operations involved in the selected topic; then press for the "what went wong" of it all. This time around, the events at Three Mile Island provided most helpful insight into operations (and breakdowns) in normal and extremely abnormal conditions.

A final note relates to the accuracy of NUKE SIM'S operation. A layman cannot acquire enough practical knowledge and understanding within 30 days to design and program an accurate-in-all-detail model of such a complex power plant. What follows, then, is an approximation which

still has many of its own surprising quirks, compounded by others more representative of the thermodynamics involved. The program, at times, develops a curious disregard for the wishes and intentions of the operator—a disregard which remains a mystery to its authors.

The following apparatus have been deleted because of memory and/or time constraints:

- 1 Steam generator
  - 3 Primary coolant pumps
  - 48 Various pumps between the turbines and the secondary feedwater pumps
  - 28 Polishers (mineral filters)
  - 2 Code relief valves
  - 1 Pressure relief valve
  - 1 Let down valve
  - 3 Core coolant pumps
- And a partridge in a pear tree.

### Workings

The operation of a nuclear power plant is much the same as that of a steam locomotive. A heat source is applied to a vessel partially filled with water, producing steam under pressure. The steam is used to either turn wheels (the *motive* in locomotive) or electrical generators (the *motive* in power plants). So, the simulator in hand is largely a plain old steam plant. A plant fired by oil, gas or coal would function in the same manner except, of course, its waste products would not require 150,000 years of close arrest.

The nuclear core in such a power plant is capable of 3,411 megawatts of thermal energy, which is available as 1092 megawatts of electricity—which amounts to 32 percent efficiency. This is the coal fire in the steam plant and heats the water in the primary loop. The water is kept at 2155 psi and 580° F to prevent the formation of steam voids in the loop of three-foot diameter pipes. Such voids are as effective as closed valves in preventing coolant flow.

The pressurizer is a large vessel connected to the "out" side of the reactor core vessel. This is known as the "hot" side of the loop since the coolant is at a high of 613° F. It is in the pressurizer that the one and only steam void is allowed to form in the primary loop. This void acts as an adjustable spring to provide pressure control in the loop; the adjustment being provided by a valve (V1) to release steam and thus pressure and a water inlet (V2) which sprays water to cool the steam and lower the pressure.

Farther along the loop is the steam generator where the heat from the primary loop is passed to the secondary loop. The temperature is thus reduced to 547° F in the primary with a corresponding rise in temperature in the secondary. The coolant now enters the primary coolant pumps.

There are two of these pumps for each of the two steam generators—and they are of interesting size and power. The 10,000 horsepower motors can push an aggregate 270,000 gallons of coolant into the core each minute. Consider for a moment the possibilities. You could fill your swimming pool in just three seconds, the overspray easily accommodating your hot tub. You could wash your car. Away. Forever. The possibilities boggle the mind! But I digress.

Also included in the primary loop is the array of pumps and valves designed to add "makeup" coolant when necessary. (This is represented in this program by a single pump -P4).

On to the secondary or auxiliary loop. The steam generator "heat sinks" the primary loop and absorbs some 66 degrees of heat, which raises the secondary coolant parameters to about 1010 psi and 547° F. The steam thus generated is directed, first, to a high pressure and, second, to a low pressure turbine and then through a condenser which sinks remaining heat to a third coolant loop. It is this third loop which finally leaves the building and is, itself, cooled in those great thumping cooling towers. The secondary coolant, now cooled to its lowest temperature, proceeds to the "polishers" where unwanted minerals are removed and then back into the generator via the feedwater pump. And so on and so on, and round and round.

### Operations

The program graphics are innocent of labels since anyone operating this program for a short length of time would soon find them redundant and distracting. Operators needing a memory refresh are advised to ask for *LIST* or *EXIT* after pushing (and patiently holding) the down arrow key in order to call the prompt—"Directive?". The *CLEAR* key is used to return from the *RODS* control.

Pumps are *PION* or *P1OFF* with the exception of pump 4, which must do double duty and so has the commands *P4IN* and *P4OUT*.

Valves are likewise as simple, *VIOPEN* or *VICLOSE* will give predictable results.

In writing this program, it became necessary to have a screen dump of the graphics drawing. To do this, a short BASIC program was written that sends the upper 120 lines of the screen to a line printer VII. This short routine remains in lines 1460 to 1530, and may be used by typing *PRINT* at the 'DIRECTIVE?' question. Do make sure your printer is on.

Further than this, there is only the random trouble generator in line 1030 to warn about. The operator is advised to remain alert or introduce the letters *REM* right after this line number. And, of course, *STOP* is used to end the program.

One last and very important note: you *must* *CSAVE* this

program immediately after typing it in!

*DO NOT* attempt to run it until you have the ML program in place and the whole thing on tape or on disk! Then, turn your CoCo off and then on again and *CLOAD* (or whatever). If the program should find an error and dump you while still in the graphics mode, you must type *A=USR1(0)* to get to someplace safe.

### The Program

The program is divided into the following sections:

10—70	Housekeeping
80—670	Graphics
680—1150	Operations
1160—1800	Commmands
1810—END	Exits

A real attempt was made to make the variables indicate their functions; such as, *ET(4)* is the Event Timer for Operating Condition 4 (*OC(4)*) and *AF(4)* is the Alarm Flag for alarm condition 4.

Subroutines were kept as close as practicable to the "front" of the program to help speed operation. Wherever possible, if an operation was to be used more than once, it was configured as a subroutine.

And that, Bro' Jake, is about as structured as we get. In the development of *NUKE SIM*, it became apparent that information in the form of text and numbers needed to be displayed on the *HI-RES* screen along with the graphics. As you may know, using *DRAW* and *LINE* is not an adequate way of putting characters on the screen, mainly because of the slow speed of interpreted BASIC and the memory requirements. Therefore, an alternate means was chosen; that is, the use of a machine language program.

This program had two basic requirements. First, it had to be invisible to the BASIC program. Second, it had to be written in Position Independent Code. The latter so that it could easily be added to the end of the BASIC program, thereby avoiding two separate loads. Those familiar with the 6809 microprocessor may already understand that this is very easy to do, whereas, with other chips, it is not so easy (Hooray 6809!).

It was decided that simple *PRINT@* statements would be used to put the text on the screen. In other words, it would intercept BASIC's print to the screen routine, draw the text, then return control to BASIC. As it turns out, there is a nice hook to use for the intercept; the hook at \$167. In Extended Color BASIC (which is what *NUKE SIM* is designed for), the byte at \$167 contains a *JMP*. The next two bytes are the location, so a new address is put there; the address of the M/L program.

In reading the listing, you may note that one other hook was used, the one at \$19A. This allows us to disable the *BREAK* key, thereby increasing the speed of the program. This routine is not foolproof; the *BREAK* key sometimes may still break, so I advise against pushing it. To exit the program, type *STOP*. This resets the hooks to their old addresses so a reset is not required.

The operation of the program will not be discussed here; the comments should shed some light. I will say, however, that an editor/assembler should be used for entering it, as it is 843 bytes long.

The steps for tying the two programs together are very simple. First, type in the BASIC program, checking for syntax errors along the way. Line 10 is very critical since this is where the machine language program is executed. The assembly program is ORGed at 0000 as is written in the



listing. Now, load the BASIC program and *PRINT PEEK(27)\*256 + PEEK(28)*. This is the end of the BASIC program. If this number were 10605, you would type *CLOADM "HIRESXT", 10605*. The M/L program is now at the end of your BASIC program.

The last step is to change the pointers at 27 and 28. Take your number (in this case 10605), and add 843 to it (843 is the length, you'll recall). The new number would be 11448. Divide this number by 256 and poke the *whole number* (positive integer) into 27.  $11448/256 = 44.71875$  so 44 would be put in 27. Now, multiply 44 by 256 and subtract this from the original number (11448). This leaves 184, so poke this into 28. Do not, repeat, *do not* run the program at this time, as other pointers are not set properly. Save this program as *NUKE SIM*. Now *CLOAD* and have a good time being a nuclear engineer.

This program is intended as an example of a simulation program to help contest entrants in *the Rainbow's* upcoming event and not as a state-of-the-art masterpiece. Time constraints prevented a full debugging, (although the opportunity to prove my theory that programs are best tested by ninth grade science students was passed up with much regret) so there are certain to be flaws in the application of the laws of thermodynamics. If the reader should come across operational quirks disturbing to the intellect, he should on no account contact the authors; who have, with the printing of this page, washed their hands of the whole mess.

**Bibliography:**

- Hodgman, Charles D., M.S. "Handbook of Chemistry and Physics" Cleveland, Ohio: Chemical Rubber Publishing Co., 1957
- Martin, Daniel "Three Mile Island: Prologue or Epilogue?" Cambridge, Mass.: Ballinger, 1980
- Nero Jr., Anthony V. "A Guidebook to Nuclear Reactors" Berkeley, Calif.: Univ. of Calif. Press, 1979
- Stephens, Mark "Three Mile Island" New York: Random House, 1980

50	06F6
130	09FE
300	0F8B
500	14A8
600	1889
800	1CF9
1000	222D
1200	274D
1400	2C79
1600	301C
1700	3358
END	366A

**The listing:**

```

1 ?*****  NUKE SIM  *****
*NUCLEAR REACTOR SIMULATOR*
*VERSION 1.0 COPYRIGHT (C)*
*1983 BY JOHN ERICKSON AND*
*CRIS LATHAM WRITTEN UNDER*
*CONTRACT FROM THE RAINBOW*
***** JESUS IS LORD *****
10 CLS: CLEAR500: A=PEEK(27)*256+P
EEK(28): A=A-843: DEFUSR0=A: DEFUSR
1=A+33: A=USR0(0): PMODE3, 1: PCLS(6
): GOSUB200: GOSUB210: PRINT@320, "
  RED SCREEN  HIT ENTER
  GREEN SCREEN HIT SPACEBAR"
20 A=RND(TIMER): A$=INKEY$: IFA$="
"THEN20ELSE IFA$=CHR$(32) THENC1=7
: C2=6ELSE IFA$=CHR$(13) THENC1=6: C
2=7ELSEGOTO20
30 CLS: A=USR1(0): DIMS0(6), S1(6),
S2(6), S3(6), S4(6), S5(3), S6(3), R1
(4), A$(1), V1$(21), AF(5), AL$(5), O
C(8), OT(8): FORI=0TO3: READS5(I), S
6(I): NEXT: FORI=0TO21: READV1$(I):
NEXT: FORI=0TO5: READAL$(I): NEXT
40 DATA 78, 100, 160, 79, 160, 43, 212
, 100, RODS, P1ON, P1OFF, P2ON, P2OFF,
P3ON, P3OFF, P4IN, P4OUT, P4OFF, HEAT
ON, HEATOFF, V1OPEN, V1CLOSE, V2OPEN
, V2CLOSE, MON1, MON2, AL, LIST, STOP,
EXIT
50 DATA REACTOR TRIPPED, PRESSURE
RELIEF VALVE OPEN, LOW COOLANT IN
STEAM GENERATOR, PRESSURIZER HEA
TER TRIPPED, SECONDARY FEEDWATER
PUMP OFF, TURBINES TRIPPED
60 TIMER=0: OT=0: RH=32: CTP=97: PP=
2155: P1=2155: PT=580: PW=200: GW=28
8: SP=1010: ST=547: OC(1)=1: OC(2)=1
: R=2129.9955: SR=2059.1161: PV=212
1.1: VS=1060.55: GV=3700: TC=547: TH
=613: A1$="V31L10004GL5G-": A2$="L
100BL5C"
70 A3$="L255V2001ADCFBP155V31ADC
FBAGEDV15ADCFBAGEDV6ADCFBV4AGED"
: GOTO1160
80 PMODE3, 1: COLOR4, 1: V$="L2D1G1D
4F1D1R2BR11R2U1E1U4H1U1L2": P$="D

```

*Now!* THE MOST COMPLETE LIST OF  
**EDUCATIONAL COLOR COMPUTER™**  
 PROGRAMS IN THE UNITED STATES

Only **\$6<sup>00</sup>** per cassette

**A partial list —**

- Add
- Algebra
- Alphabet
- Planetary Positions
- Flash cards for German, French, Spanish, States and Capitals
- Biology
- Weather Forecaster
- Physics

Programs for — TRS 80 Color Computer, VIC 20, Atari 400, Timex-Sinclair

**Many more!** From Kindergarten through graduate courses. All cassettes \$6<sup>00</sup> each. Write for free list.

**MOSES ENGINEERING COMPANY**

P. O. Box 11038 • Ardmore Hwy. Station  
 Huntsville, Alabama 35805  
 (205) 837-3356

## Double Density Software

### COLOR TERM + PLUS +

An Intelligent Terminal Program For The Color Computer or TDP 100.

**Features:**

- BAUD RATE — 110 to 19200
- Half or Full Duplex
- One or two Stop Bits
- Odd, Even or No Parity
- Word WRAP
- Turn off Lowercase Letters
- Send All Control Characters
- Print Buffer
- Examine Buffer
- Send & Receive BASIC or Machine Language Programs or Files.
- Editor allows entry of text into Buffer as well as Editing of Buffer.
- (Disk Version Has more powerful Editor)



**Special Feature:**

Code & Decode **ANYTHING** in the Buffer for Secure Transmission or Storage Using a User defined key word  
PRICE \$29.95 (Tape) \$39.95 (Disk) 16k or 32k Req.

#### TAPENAME

**Tapename** searches tape and stores the name of any program or file. You can print the information to the screen, printer or tape. Also checks for load errors.  
4k, 16k, or 32k Req. or Ext. BASIC.  
PRICE \$7.95 (tape)\* D

#### COLOR DISK SAVER

Saves a disk to tape. Reloads disk from saved tape. Also has tape verify command! 32k Ext. BASIC Req.  
PRICE \$12.95 (tape)\*\* D

#### CURSOR II

Hate that blinking cursor? Tired of seeing the computer print "OK" after your program just bombed? **Cursor II** changes the cursor to a solid, non-flashing red. Enter any message up to 200 characters in length. Your message will be displayed instead of "OK".  
4k, 16k, or 32k Req. or Ext. BASIC.  
PRICE \$4.95 (tape)\*

#### SUPER PEEKER

This is a BASIC program that will allow the user to explore the inside of the color computer. Explore the possibilities with **Super Peeker**.  
16k or 32k Ext. BASIC Req.  
PRICE \$9.95 (tape)\*\*

**COLOR BIORHYTHM** Are you up or down today, tomorrow, or years from now? Find out with **COLOR BIORHYTHM**. Uses high res graphics. Send the chart to printer. 16k or 32k Ext. BASIC Req.  
PRICE \$14.95 (tape) D

**DD CLOCK** Don't forget what time it is when you are programming. The time is displayed in the upper right corner of your screen. Shows hours, minutes and seconds. Beeps every hour.  
4k, 16k, or 32k. (Ext. BASIC not required.)  
PRICE \$9.95 (tape)\* D

**AUTO LOAD** Auto Load will put **any** program or file from tape to disk! All machine language programs that load below the top of your disk system are modified so that they will operate properly with a disk system!  
16k or 32k Ext. BASIC Req  
PRICE \$12.95 (tape)\*D

**\*Software Authors Note\***

We are looking for quality software. If you have a program you think is a winner, send it to us. If it meets our standards, you will be paid TOP royalties.

## Double Density Software

**NEW!**

#### UNDERGROUND

Tired of playing adventure games that have a limited vocabulary? **Underground** gives a detailed description of your surroundings, just like a main-frame adventure! There are over 90 separate rooms, passageways, etc. Discover what the mysterious machine does, what lies in the Egyptian sarcophagus, how do you tame the guardian of Hell's Gate, where is the fabled golden apple? Everything is up to you. You give the orders, you are the hero. This adventure is not for the faint of heart! You can suspend your game at any time and continue later. Takes from 5 to 20 hours to play.  
32K ext. BASIC Req. PRICE \$26.95 Disk only

**NEW!**

#### COLOR DOCTOR

Discuss your problems with your computer. **Color Doctor** will discuss your problems with you. This is a great party program! Your friends will not believe that your computer is *talking back to them!* Is it intelligent? It sure seems like it!  
16K ext. BASIC Req. PRICE \$15.95 (tape) D

**NEW!**

#### GALACTIC MATH

Load this game into your computer and start playing! This is a math tutor that is really an arcade game! Keep those saucers from landing! There are no "happy faces" or "funny clowns" in this math program. This is a multi-level addition and multiplication quiz. You select the difficulty level. This program uses high resolution color graphics and shows the score, elapsed time, number of hits, number of misses and number of "bases" left to the player. Adults may start this game, but the *kids* will finish it! This program has been teacher and kid tested. Realistic explosions and laser fire sounds make this program a winner! This program rates an A+. For grades 1 and up. 16K or 32K Ext BASIC Req. PRICE \$15.95 (tape) D

**NEW!**

#### COLOR KEY COMMAND

Looking for a powerful programmer's aid, but you don't have a fortune to spend? This program is for you! Look at these features: two keystroke entry of more than 80 Basic, Extend Basic, and Disk Basic commands. Select the color of your cursor. Select the prompt you want -- no more "OK" when a program bombs! Automatic line numbering -- you select the start line and increment! 4 custom programmable keys for a total of 64 characters each -- enter whole lines with two key presses! Copy any line with the copy command. Merge tape programs together automatically. Redefine any or all keys with a short basic program we supply. How can you get all this and more for so little? Because you make the keyboard overlay! We give you a template with all commands printed on it -- you cut it out and use it. That is all there is to it! Note: Not all features are available on every machine; some require Extended or Disk Basic to work properly. 16K or 32K Req. PRICE \$18.95 (tape)\* D

- \* All machine code D Disk Compatible
- \*\* BASIC with machine code subroutines

Specify Disk when ordering and add \$5.00 per program. Save money and ask that all ordered programs be loaded on one disk. You pay only for the one disk! Please add \$2.00 shipping and handling on all orders. No extra charge on COD orders, Mastercard and VISA accepted. Charge orders add 3%. Texas residents add 5% sales tax. Allow two weeks for personal checks. Your order will usually be shipped within two or three days. We will notify you of any problems within one week. Send 20 cent stamp for free catalog.

Send orders to:

DOUBLE DENSITY SOFTWARE



920 Baldwin Street  
Denton, Texas 76201  
Phone 817/566-2004.



```

10L24U10R6E6R6F6":FORI=1T04:PCLS
1:DRAW"BM24,6XP$;":ONI GOTO90,10
0,110,120
90 GET(6,1)-(22,15),S0,G:DRAW"BM
15,1D14R2U14":GET(6,1)-(22,15),S
1,G:NEXT
100 DRAW"BMB,8R14D1L14D1R14":GET
(6,1)-(22,15),S2,G:NEXT
110 DRAW"BM11,3M+12,+10D1M-12,-1
0D1M+12,+10":GET(6,1)-(22,15),S3
,G:NEXT
120 DRAW"BM22,3M-12,+10D1M+12,-1
0D1M-12,+10":GET(6,1)-(22,15),S4
,G:PCLS1
130 DRAW"C1;BM0,0R2D1;C4D33L2NU3
3D1":COLORC1:DRAW"R2":GET(0,0)-(
3,35),R1,G:COLOR4:PCLS1:GOSUB140
:GOSUB150:GOSUB370:GOSUB400:GOSU
B160:GOSUB260:GOSUB430:GOSUB510:
PAINT(31,112),C1,4:GOSUB200:GOTO
210
140 DRAW"BM73,107D6L44U10L15U40R
15U58R104D102R74D6L110U6R28U96L8
9D43R28D32R20U6L4H8U21L14U40R6D3
6R8E8R4U28R6D28R4F8D25G8L4D10L31
U32L22D5R14D40L14D4R35BMB0,70R14
D5L14U5BMB4,0D5R6U5BMB255,107L24D
6R24BMB58,0D5R6U5":RETURN

```

```

150 DRAW"BM124,100NU80L6H8U65E8R
6BR8ND80R7F8D3R8U6R8D12L16D14R8D
6L8D30R8D6L9G8L5BM179,24NL8D6R28
U6R8D12L44U12BM222,24D62L12U5H3L
8ND17L9G3D5L8D6R8D5F3R3NU17R11NU
17R3E3U5R20U68L7":RETURN
160 DRAW"BM178,50R26D18R18D6L25U
18L18U6BM255,68L24D6R24BM183,24L
32U19R32D19U8NR19U1NR19U1NR19U1R
19U8D19R32U19NL32D8R21D1L21D1R21
D1L21BM230,40R10D4R15BD4L15D8R15
BD4L15D4L10BL8L10U24R9"
170 DRAW"BM180,16L3G5L15U5L4U3R4
U5R15F5R4":PAINT(162,15),4,4:DR
W"BM232,16L3G5L15U5L4U3R4U5R15F5
R4":PAINT(228,15),4,4
180 DRAW"BM96,105XP$;BM178,48XP$
;BM178,84XP$;BM230,105XP$;BM56,2
0XV$;BM82,20XV$;":PAINT(60,0),C2
,4:PAINT(60,20),C2,4:PAINT(218,7
3),C2,4:PAINT(235,73),C2,4:PAINT
(234,112),C2,4:LINE(215,51)-(239
,51),PSET:PAINT(227,52),C1,4:PAI
NT(227,50),4,4
190 PAINT(194,35),4,4:PAINT(217,
52),C2,4:PAINT(237,52),C2,4:PAIN
T(217,50),C1,4:PAINT(237,50),C1,
4:COLORC1:LINE(215,51)-(221,51),
PSET:LINE(233,51)-(239,51),PSET:
COLOR4:RETURN
200 PRINT@320,STRING$(192," ");:
RETURN
210 PMODE4,1:SCREEN1,1:PMODE3,1:
RETURN
220 REM RODS UP OR DOWN
230 IFCTP>100THENRETURNELSERM=FI
X((CTP+1)/3):IFRM=RH THENRETURN
LSEIFRM>RH THEN250ELSEFORK=RM TO
RH:GOSUB260:RH=RH-1:NEXTK
240 RH=FIX((CTP+1)/3):RETURN
250 FORK=RH TORM:GOSUB260:RH=RH+
1:NEXTK:GOTO240
260 PUT(20,62-RH)-(23,97-RH),R1,
PSET:RETURN
270 REM PUMP MOTORS
280 WP=WP+1:IFWP=5THENWP=1
290 FORI=0T02:IFOC(I+1)=0THENGOS
UB350:NEXTELSEONWP GOSUB310,320,
330,340:NEXT
300 IFOC(I+1)=0THEN350ELSEIFOC(I
+2)=1THENONWP GOTO310,320,330,34
0ELSEONWP GOTO310,340,330,320
310 PUT(S5(I),S6(I))-(S5(I)+16,S
6(I)+14),S1,PSET:RETURN
320 PUT(S5(I),S6(I))-(S5(I)+16,S
6(I)+14),S4,PSET:RETURN
330 PUT(S5(I),S6(I))-(S5(I)+16,S
6(I)+14),S2,PSET:RETURN
340 PUT(S5(I),S6(I))-(S5(I)+16,S
6(I)+14),S3,PSET:RETURN

```

**TRANS  
TEK**

See you at RAINBOWfest!

**C.C.Calc** \$25  
Our own Electronic Spreadsheet for the Color Computer is a sophisticated but easy to use calculating and planning program. C.C.Calc takes the drudgery out of budgeting, taxes, and other planning activities. Reviewers have called it "Impressive", "Just Right", and "Powerful". You'll call it a Great Value. 32K Cas. or Disk.

**C.C.File** \$7  
A nifty little data base package with lots of uses.

**C.C.Writer** \$30  
A quick to learn and easy to use word processor. Right justification, Global commands, etc. Works with any printer including daisy wheels. 16-32K Cas, 32K Disk.

**C.C.Mailer** \$20  
Mailing list data base for CoCo and any printer. From 90 to over 1000 records depending on your system. The C.C.Merger option merges Name and Address with C.C.Writer letters. Up to 4 line Address. Disk or Cassette - \$20. With C.C.Merger option - \$25 (Requires C.C.Writer)

**Mailer/Merger/Writer Pkg.** \$50

**TransTek**  
194 Lockwood  
Bloomington, IL 60108  
(Personal Checks are Welcome)





```



350 PUT (S5(I), S6(I)) - (S5(I) + 16, S
6(I) + 14), S0, PSET: RETURN
360 REM VALVE 1 OPEN OR CLOSED
370 IFOC(7) = 0 THEN 380 ELSE DRAW "C1B
M86, 24R14U3D6BM90, 24C4R14U3D6": A
= PPOINT(86, 26): COLOR A: DRAW "BM86,
0D4R2U4BD12D12L2U12": COLOR 4: RETU
RN
380 DRAW "C1BM90, 24R14U3D6BM86, 24
C4R14U3D6": DRAW "BM86, 0C1D4R2U4BD
12D11L2U11": COLOR 4: RETURN
390 REM VALVE 2 OPEN OR CLOSED
400 IFOC(8) = 0 THEN 410 ELSE DRAW "C1B
M62, 24L14U3D6C4BM58, 24L14U3D6": C
OLORC2: DRAW "BM60, 24D26R2NU26R10U
1L10U1R10": RETURN
410 DRAW "C1BM58, 24L14U3D6C4BM62,
24L14U3D6": A = PPOINT(74, 48): COLOR
A: DRAW "BM60, 25D25R2NU25R10U1L10U
1R10C4": RETURN
420 REM PRESSURIZER WATER LEVEL
430 PW(1) = FIX((PW - 100) / 17): IF PW <
101 THEN 460 ELSE IF PW > 400 THEN 470 EL
S IF PW(1) = PW(2) THEN RETURN ELSE PW(
2) = PW(1): PW(3) = 0: COLORC2: GOSUB 45
0: LINE(74, 68 - PW(1)) - (102, 68 - PW(1
)), PSET: PAINT(86, 68 - PW(1) + 1), C1,
C2: PAINT(86, 68 - PW(1) - 1), 4, C2: COL
OR 4
440 LINE(74, 68 - PW(1)) - (102, 68 - PW

```

```

(1)), PSET: GOSUB 450: COLORC1: LINE(
84, 80) - (90, 80), PSET: COLOR 4: GOSUB
370: GOTO 400
450 DRAW "BM84, 80L4H8U25E8R4U15R6
D15R4F8D25G8L10BM80, 70R14D5L14U5
": RETURN
460 PW(2) = 5: IF PW(3) = 1 THEN RETURN
LSE PW(3) = 1: COLORC2: GOSUB 450: PAIN
T(86, 79), 4, C2: COLOR 4: GOSUB 450: CO
LORC1: LINE(84, 80) - (90, 80), PSET: C
OLOR 4: GOSUB 370: GOTO 400
470 PW(2) = 5: IF PW(3) = 1 THEN RETURN
LSE PW(3) = 1: COLORC2: GOSUB 450: PAIN
T(86, 25), C1, C2: COLOR 4: GOSUB 450: C
OLORC1: LINE(84, 80) - (90, 80), PSET:
COLOR 4: GOSUB 370: GOTO 400
480 REM HEATON OR HEATOFF
490 IFOC(6) = 1 THEN PAINT(87, 74), C1
, 4: RETURN ELSE PAINT(87, 74), 1, 4: RE
TURN
500 REM STEAM GENERATOR LINE 2
510 GW(1) = FIX((GW - 30) / 11.4): IF GW
< 30 THEN 570 ELSE IF GW(1) = GW(2) THEN R
ETURN ELSE GW(2) = GW(1): IF GW > 600 THE
N RETURN ELSE GW(3) = 0: COLORC2: GOSUB
550: LINE(113, 86 - GW(1)) - (122, 86 - G
W(1)), PSET: LINE(135, 86 - GW(1)) - (1
44, 86 - GW(1)), PSET
520 A = PPOINT(146, 86 - GW(1)): IFA = C
2 OR A = C2 - 4 THEN 530 ELSE LINE - (154, 8
6 - GW(1)), PSET
530 PAINT(116, 86 - GW(1) + 1), C1, C2:
PAINT(137, 86 - GW(1) + 1), C1, C2: PAIN
T(116, 86 - GW(1) - 1), 4, C2: PAINT(137
, 86 - GW(1) - 1), 4, C2: COLOR 4: LINE - (1
35, 86 - GW(1)), PSET: LINE(113, 86 - GW
(1)) - (122, 86 - GW(1)), PSET: IF PPOIN
T(199, 99) = 4 THEN COLORC1: GOSUB 560:
PAINT(199, 99), C1, C2
540 IF PPOINT(199, 99) = 8 THEN COLORC
2: GOSUB 560: PAINT(199, 99), C1, C2: C
OLOR 4: GOSUB 560: GOTO 550 ELSE GOTO 55
0
550 DRAW "BM124, 100NU80L6H8U65E8R
6BR8ND80R7F8D3R8U6R8D12L16D14R8D
6L8D30R8D6L9G8L5": IFAF(5) = 1 THEN D
RAW "BM154, 30R8": LINE(154, 25) - (15
4, 29), PRESET: LINE(162, 25) - (162, 2
9), PRESET: RETURN ELSE RETURN
560 DRAW "BM222, 51D35L12U5H3L8ND1
7L9G3D5L8D6R8D5F3R3NU17R11NU17R3
E3U5R20U41L7": RETURN
570 GW(2) = 30: IF GW(3) = 1 THEN RETURN
ELSE GW(3) = 1: COLORC2: GOSUB 550: PAI
NT(136, 99), 4, C2: PAINT(121, 99), 4,
C2: GOSUB 560: PAINT(199, 99), 4, C2: C
OLOR 4: GOSUB 550: GOTO 560
580 REM PRIM LOOP WATER INLET
590 IFOC(4) = 1 AND OC(5) = 0 THEN PAINT
(243, 112), C1, 4: COLORC1: GOTO 600 EL

```





**PREMIUM SOFTWARE  
FOR THE COLOR COMPUTER**

SISI (16K EXT. BASIC)	\$9.95
Sisi the fortune telling computer uses data that you input to determine a character reading for you.	
COLORHYTHM (16K EXT. BASIC)	\$9.95
Plots your biorhythm in hi-res graphics for 15 days.	
PRESCHOOL PAK (16K EXT. BASIC)	\$8.95
Two preschooler learning drills. Contains ALPHABET & COUNTER. Makes use of hi-res graphics and sound. The kids think it's a game!	
MONEY MINDER II (16K)	\$14.95
A cassette based personal finance program. Up to 56 user definable budget categories. Printout capability. Menu driven—easy to use.	
DISK MONEY MINDER (32K plus disk)	\$19.95
Similar to MONEY MINDER II but for use with disk. Easier and faster to use.	

**HARMONYCS**

P.O. BOX 1573  
SALT LAKE CITY, UTAH 84110



```

SEIFOC(4)=1THENPAINT(243,112),C2
,4:COLORC2:GOTO600ELSEPAINT(243,
112),C2,4:COLORC1
600 DRAW"BM204,112L70U1R70U1L70U
1R70U1L70C4":RETURN
610 REM PUMP3 WATER INLET
620 IFOC(3)=1THENCOLORC2:DRAW"BM
152,51L4D1R4D1L4D1R4D1L4":COLOR4
:RETURNELSEDRAW"BM152,51L4D1R4D1
L4D1R4D1L4":GW(2)=60:GOTO510
630 DRAW"BM46,6R9F1L12G1R15D1L15
F1R12BM106,6R13F1L15D1R15D1L15F1
R13":RETURN
640 COLORC1:GOSUB630:COLOR4:RETN
RN
650 COLOR1
660 DRAW"BM154,25R8D1L8D1R8D1L8D
1R8BR8R8U1L8U1R8U1L8U1R8BR28R8D1
L8D1R8D1L8D1R8BR8R8U1L8U1R8U1L8U
1R8":IFPPOINT(154,25)=5THENCOLOR
4ELSECOLOR1
670 DRAW"BM164,30D6R2U6R2D6BR48U
6R2D6R2U6":COLOR4:RETURN
680 PO=(3411*CTP*.0032):IFAF(5)=
1THENPO=0:RETURNELSERETURN
690 AT$="":CC=0
700 A$=INKEY$:IFA$=""THEN700ELSE
IFLEN(AT$)>10THEN1370ELSEIFA$=CH
R$(13)THENRETURNELSEIFA$=CHR$(8)

```

```

THEN710ELSEIFA$<CHR$(48)THEN700E
LSEAT$=AT$+A$:CC=CC+1:PRINTA$;:S
OUND150,1:GOTO700
710 IFCC=0THEN700ELSECC=CC-1:SOU
ND150,1:PRINTA$;:AT$=LEFT$(AT$,C
C):GOTO700
720 T=FIX((TIMER+OT)/60):IFTIMER
=>60000THENOT=OT+TIMER:TIMER=0:R
ETURNELSERETURN
730 IFP1<400THENIV=1.17:RETURNEL
SEIV=.4:RETURN
740 PRINT@448,USING"Elapsed time
: ### min ## sec";FIX(T/60);(T
-FIX(T/60)*60):RETURN
750 IFINKEY$=CHR$(12)ORPEEK(342)
=247THENRETURN
760 IFP1=>2500THENGOSUB1830:PRIN
T@320,"**PRESSURE ABOVE DESIGN L
IMITS** ***SIMULATION OVER**
*":GOTO1110
770 IFP1=>2355ORPT>620THENCTP=7:
GOSUB1420:GOSUB230:GOTO790ELSEIF
P1<1650ANDPT>575THENCTP=7:GOSUB1
420:GOSUB230:GOTO790
780 GOTO800
790 IFAF(0)=0THENGOSUB1840:FORI=
1TO2:PLAYA1$:PRINT@480,"*****
REACTOR TRIPPED*****";CHR$(5
);:PLAYA2$:NEXT:AF(0)=1
800 IFP1=>2255ANDOC(7)=0THENOC(7
)=1:ET(7)=T:GOSUB370ELSE820
810 IFAF(1)=0THENGOSUB1840:FORI=
1TO2:PLAYA1$:PRINT@480,"***PRESS
URE RELIEF VALVE OPEN***";CHR$(5
);:PLAYA2$:NEXT:AF(1)=1
820 IFEM(3)=1THENPW=PW-((T-ET(9)
)*.01667):ET(9)=T:VS=PV-(PW*5.3)
:GOSUB430:GOSUB1130:GOSUB1150
830 G2=GV-(GW*5.72):IFGW<150THEN
GF=GW/150ELSEIFGW>150ANDGF<300TH
ENGF=1ELSEIFGW>300THENGF=GW/300
840 TC=TH-(CTP*.01*66*GF)
850 ST=TC:SP=(ST+460)*SR/G2:IFOC
(2)=0ANDAF(5)=0THENGOSUB650:GOSU
B1840:FORI=1TO2:PLAYA1$:PRINT@48
0,"*****TURBINES TRIPPED*****
***";CHR$(5);:PLAYA2$:NEXT:AF(5)
=1
860 IFOC(2)=1ANDGW>100ANDAF(5)=1
ANDSP<1110THENGOSUB660:AF(5)=0
870 IFGW<100ANDAF(2)=0THENFORI=1
TO2:PLAYA1$:PRINT@480,"*LOW COOL
ANT IN STEAM GENERATOR*";CHR$(5)
;:PLAYA2$:NEXT:AF(2)=1
880 IFGW>100ANDAF(2)=1THENAF(2)=
0
890 IFPW<101THENOC(6)=0:GOSUB490
ELSE910
900 IFAF(3)=0THENGOSUB1840:FORI=
1TO2:PLAYA1$:PRINT@480,"***PRESS

```

## COLOR-FORTH

Including SEMIGRAPHIC-8 EDITOR  
+ UTILITIES

- Disk and Tape utilities
- Boot from disk or tape
- Graphics and Sound commands
- Printer commands
- Auto-repeat and Control keys
- Fast task multiplexing
- Unique TRACE function in kernal
- Clean INTERRUPT handling in HIGH-LEVEL FORTH
- CPU CARRY FLAG accessible
- Game of LIFE demo
- ULTRA FAST:written in assembler
- Directions included for installing optional ROM in disk controller or cartridge
- Free Basic game "RATMAZE"



\$58.95

# FORTH

HOYT STEARNS ELECTRONICS  
4131 E. CANNON DR. PHOENIX, ARIZONA 85028

602-996-1717

# - COMPUTER SHACK -

## COLOR DFT (Direct File Transfer) Disk or Tape

At last a terminal program for the color computer that allows you to send and receive machine language programs without any conversion routines. Send directly from disk to disk or tape to disk. DFT will send and receive any type of program machine language, basic, text files, data files etc. from a color computer, Model I, Model III or a Bullet 80 system. DFT has a chat mode and has software controlled half and/or full duplex. You must have a modem in order to use DFT.

Tape Version ..... **\$24.95** Disk Version ..... **\$29.95**

## COLOR TAPE COPY \$15.95

By Bob Withers

There have been few copy programs on the market for the Color computer but none can compare with Color Tape Copy. This program is designed so that you don't lose any of your valuable programs or data bases.

It will make a backup of any Color Computer Tape; Machine language, data, or basic program.

First load color tape copy into your CC. Then it prompts you to put your original copy into the recorder. After it loads the program into memory it tells you to put a blank tape into the recorder and press the record button. It then writes the program to a new tape.

You'll never have to worry about your little kids destroying your \$20.00 tapes. 16K.

## TELEWRITER - 64

Best word processor for the Color Computer.

Tape ..... **\$49.95** Disk ..... **\$59.95**

## DRAGONQUEST

A new text adventure by Charles Forsythe. You must rescue the princess from the Smaaeor Monarch of Dragonfolk. All Machine language. Fast, Exciting and only ..... **\$15.95**

## MADNESS AND THE MINOTAUR

A classic adventure game utilizing two word commands.

Price ..... **\$19.95**

## BUGOUT

A compact but very powerful monitor for the 6809 microprocessor. Only ..... **\$19.95**

## MISADVENTURE SERIES

### MADAM ROSA'S MASSAGE PARLOR

Tape ..... **\$15.00**

### WET T-SHIRT CONTEST

Tape ..... **\$15.00**

## COMPUTER SHACK'S BOOK STORE

### PROGRAMMING THE 6809

By Rodney Zaks & William Labiak

**\$14.95**

This book explains how to program the 6809 in assembly language, covering all aspects progressively and systematically. Beginning with the basics of programming, **Programming the 6809** goes on to explain registers and buses, subroutines, the 6809 instruction set, addressing modes, I/O techniques and devices, and finally, data structures. With this knowledge you will be able to give your 6809 processor 16-bit performance with 8-bit economy. No prior programming knowledge is required.

### TRS-80 COLOR PROGRAMS

by Tom Rugg and Phil Feldman

**\$19.95**

Here are 37 fully documented programs ready to type into your color computer. These programs promise to be educational, practical, and in almost all cases, fun. 332 pages.

### COLOR COMPUTER GRAPHICS

by Ron Clark

**\$9.95**

The complete handbook on how to do color video graphics, with ready to run programs. Learn all about low, medium and high-resolution graphics, and how to create each. 138 pages.

### TRS-80 COLOR BASIC

by Bob Albrecht

**\$9.95**

With this book you can teach yourself BASIC, the language of the TRS-80 and many other computers. Packed with games, experiments, programming problems and solutions, this entertaining self-instructional book is the ideal introductory aid for kids, parents and teachers. 378 pages.

### TRS-80 COLOR COMPUTER GRAPHICS

by Don Inman

**\$14.95**

Explore the creative and imaginative blending of computers and color using Color Computer Graphics. This book will enable you to explore all the graphics capabilities of Extended Basic. you will learn how to create interesting graphics to enhance your own computer programs. The book also provides application programs and useful subroutines. 303 pages

### COLOR COMPUTER SONGBOOK

by Ron Clark

**\$7.95**

40 of the world's best known songs, scored for easy playing on the TRS-80 Color Computer, including many favorite popular, classical, folk and seasonal musical selections. Some of which include Dixie, Minuet, Greensleeves, Jingle Bells, Yellow Rose of Texas, etc. 96 pages

# COMPUTER SHACK

1691 Eason • Pontiac, Michigan 48054

Info: (313) 873-8700 • Orders: CALL TOLL FREE (800) 392-8881

Master Charge and VISA OK. Please add \$3.00 for shipping in the U.S.A. - \$5.00 for Canada or Mexico - Proper postage outside of U.S. - Canada - Mexico.  
Dealers: We are distributors for all items in this ad. Write for our catalog and price list.



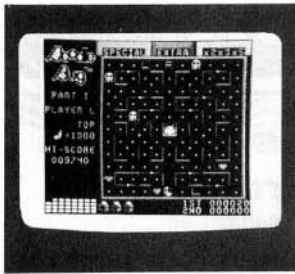

### DOODLE BUG

DOODLE BUG is a machine language high resolution graphics game for one or two players who move their Ladybugs through an ever-changing maze gobbling dots and other items while avoiding Enemy bugs and Skulls. Excellent Graphics. Similar to Lock N' Chase™. Tape... \$24.95 Disk... \$29.95

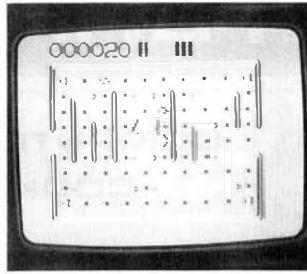

### PACDROIDS

With its space theme, the Super Saucer lays destructomines and the Super Bomb that disintegrates everything in your path, right up to the wall. The maze changes every 10,000 points as the difficulty escalates. 1-4 players. 16K extended basic. Tape..... \$19.95



### COLORPEDE

Colorpede has a variety of bugs ranging from a tiny beetle to the gigantic colorpede. Colorpede has better graphics than Katerpillar but the sound is not as good. Colorpede also has a more varied and complicated play routine. 16K. Tape..... \$29.95



### DONKEY KING

Using the four stages from the original arcade game, with your joystick in hand try to jump the barrels, collect the pins, maneuver your way past the falling jacks, and figure out the crazy conveyor belts. Written by Tom Mix, this one's sure to become a classic! 32K. Tape... \$24.95 Disk... \$27.95

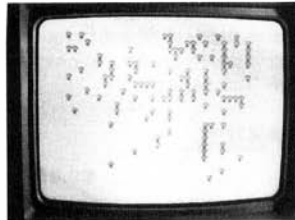

### MEGAPEPE

Could this be the best Centipede yet? Computerwares new addition to the field, super graphics and sound. Tape... \$21.95 Disk... \$26.95

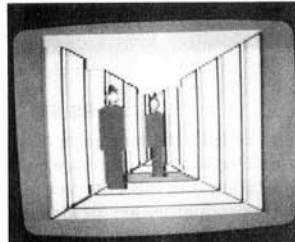

### PHANTOM SLAYER

You must chase the phantoms and kill them with your assortment of weapons. This is a graphics type maze/adventure game with full screen three dimensional graphics. You are armed with a laser pistol, and proximity detector. 16K. Tape..... \$19.95

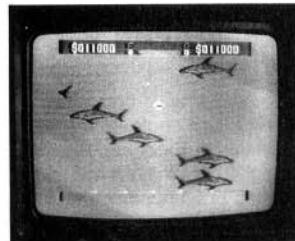

### SHARK TREASURE

Dive down through the sharks and salvage the gold. Armed with special flash bombs you fight off the sharks. Excellent game. Great graphics, sound. From Computerware. Tape... \$21.95 Disk... \$26.95

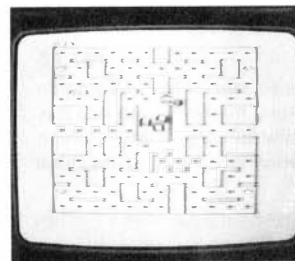

### GHOST GOBBLER

Ghost Gobbler is an excellent version of Pac-Man™. You must gobble all the food dots while avoiding the ghosts. There are four energizer dots which will make the ghosts turn blue and become scared. This is the best copy of the arcade game. 16K. Tape..... \$21.95

Now you can deduct up to 20% on the price of games: buy any 2 games deduct 10%, buy any 3 games deduct 15%, buy any 4 games deduct 20% from games prices.

**TOP TEN**

**FOR THE COCO**

- 1)..... DONKEY KING
- 2)..... COLORPEDE
- 3)..... DOODLE BUG
- 4)..... PLANET INVASION
- 5)..... SPACE RACE
- 6)..... ASTRO BLAST
- 7)..... SHARK TREASURE
- 8)..... PACDROIDS
- 9)..... HAYWIRE
- 10)..... RAIL RUNNER

### ROBOTTACK

Maneuver your way around the screen in a last desperate attempt to save the human family. As the robots grow in number, use your lasers to eliminate them and your superior maneuvering to avoid their deadly grip. ROBOTACK is a 100% machine, 1 to 2 player arcade action game for the entire family. 16K CoCo. Tape... \$24.95 Disk... \$27.95

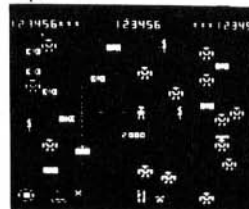

### HAYWIRE

This is Mark Data's version of Beserk™. Super Colors and dynamic sound effects in this fast paced arcade game for one or two players. The exciting combination of angry robots on the Indestructible Menace will provide hours of action filled fun. Tape..... \$24.95

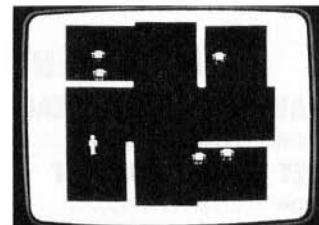

## COMPUTER SHACK

1691 Eason • Pontiac, Michigan 48054

Info: (313) 873-8700 • Orders: CALL TOLL FREE (800) 392-8861

Master Charge and VISA OK. Please add \$3.00 for shipping in the U.S.A. - \$5.00 for Canada or Mexico - Proper postage outside of U.S. - Canada - Mexico. Dealers: We are distributors for all items in this ad. Write for our catalog and price list.

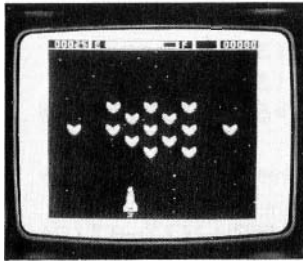

### ASTRO BLAST

Your routine space patrol in an outer galaxy sector becomes a life and death struggle with alien invasion forces advancing towards Earth. Wave after wave of attack squadrons challenge you in this super hi-res machine language shoot-em-up game. One or two players. 16K  
Tape version..... **\$24.95**

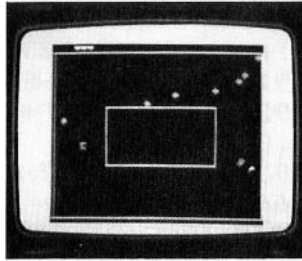

### SPACE RACE

Maneuver your ship around the four cornered "race track" in space while destroying hordes of alien ships. As you fly around the "race track" bouncing off the walls, watch out for mines laid by the swarms. Great color and sound and a new approach. 16K  
Tape..... **\$21.95**

20+24 = 1

**YES THATS RIGHT 20 PLUS 24 EQUALS 1. TRANSLATED THAT MEANS 20% DISCOUNT ON SOFTWARE ORDERS OF 4 OR MORE ITEMS PLUS 24 HOUR DELIVERY MAKE US YOUR #1 DEALER. TRY US AND SEE! WE HAVE OVER 50 DIFFERENT PROGRAMS FOR THE COLOR COMPUTER.**

Four great reasons why you should buy from Computer Shack (1) We have a toll free line, it costs you nothing to call us. (2) We ship all orders out within 24 hours (3) Most of our salespeople have color computers and they will be more than happy to help you pick out games, books, etc. (4) If you buy more than one program we will give you a discount. If you buy 2 programs you can take 10% off both programs. If you buy 3 programs you can take 15% off, and if you buy 4 or more programs you can take 20% off the price of all four.

We are still in need of some additional people to add to our top ten panel. If you are interested send us a listing of your 10 favorite games.

We carry many programs that are not in our ad's, please call if there is a special program you want.

### SPACE TRADER

Establish vast interstellar shipping lanes and purchase stock in the companies that control those trade routes. This is a multi-player board game with graphics. This is a game for the thinkers, it takes more than a quick hand to win this one. 16K  
Tape..... **\$21.95**

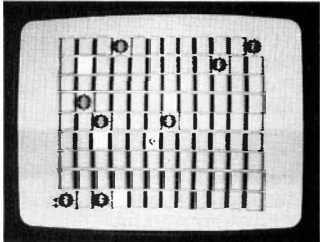

### PLANET INVASTION

A great new Defender action game, its success insured by its spellbinding graphics and marvelous sound, but most of all by its controlability. Using both the keyboard and the joystick, you maneuver your way through this revolutionary new game. 16K  
Tape..... **\$21.95**

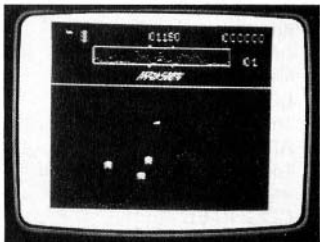

### MONKEY KONG

Once again, Mario jumps into action. Avoiding rolling barrels, ramps, ladders, and killer flames while trying to save the beautiful girl from the clutches of the giant ape. Written by Ken Kalish its so much like the arcade version, you might try to insert a quarter. 16K  
Tape..... **\$19.95**

### RAIL RUNNER

Something like Frogger". But with a difference. Excellent hi res graphics and exciting play.  
From Computerware.  
Tape... **\$21.95** Disk... **\$26.95**

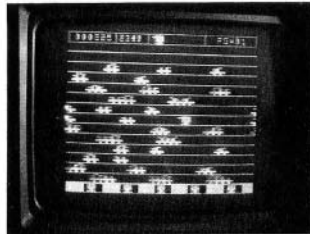

### VENTURER

Fantastic arcade game comes to life on your Color Computer screen. Upon entering each room you'll find new treasures and new challenges. Using your joystick, get the treasure while fending off the attacking creatures. This great new adaptation be Aardvark will put excitement back into your Color Computer. 16K  
Tape..... **\$19.95**

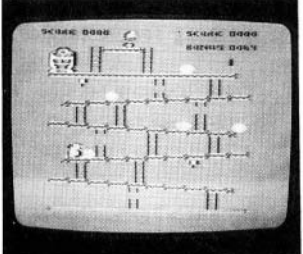
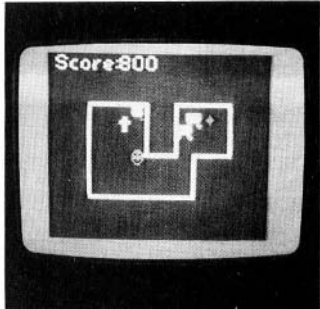

### GOLF

Aardvark has brought this age old game to your Color Computer. With sandtraps, trees, water holes, and a great sound track, you just might mistake it for the real thing. Choose your club and select a swing, if you make it to the green you can even putt. 16K extended color basic.  
Tape..... **\$9.95**

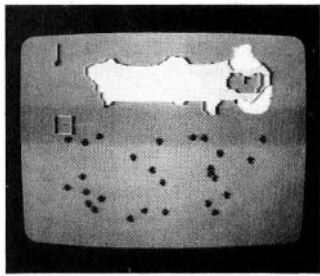

COMPUTER SHACK

1691 Eason • Pontiac, Michigan 48054  
Info: **(313) 873-8700** • Orders: **CALL TOLL FREE (800) 392-8861**

Master Charge and VISA OK, Please add \$3.00 for shipping in the U.S.A. - \$5.00 for Canada or Mexico - Proper postage outside of U.S. - Canada - Mexico.  
Dealers: We are distributors for all items in this ad. Write for our catalog and price list.

# SAVE!!!

INTRODUCING ARIZONA DISCOUNT SOFTWARE!

We pledge to bring you the best software and hardware values for your Color Computer and TDP-100! All software is always at least 15% off. And we are not talking about "Close Outs" but first line software from some of the best Color Computer software manufacturers. Names like Tom Mix, Computerware, Prickly Pear, Petrocci and Cognitec!

Our name may say software, but we have hardware values too. So before you buy anything for your Coco, check with Arizona. We can probably get it for you for less!!

## SOFTWARE BARGAINS!!!

15% OFF

*32 K Program	TAPE		DISK	
	List Price	Our Price	List Price	Our Price
<b>TOM MIX</b>				
Donkey King	24.95	21.20*	27.95	23.75*
Protectors	24.95	21.20*	27.95	23.75*
Katerpillar Attack	24.95	21.20	27.95	23.75
Solo Pool	17.95	15.25		
<b>PETROCCI</b>				
Inspector Clueseau	19.95	16.95*		
Stagecoach (New!!)	19.95	16.95		
<b>COMPUTERWARE</b>				
Synther 7 (New!!)	21.95	18.65	26.95	22.90
Shark Treasure (New!!)	21.95	18.65	26.95	22.90
El Diablero	19.95	16.95	24.95	21.20
Doodle Bug	24.95	21.20	29.95	25.45
Megapede	21.95	18.65	26.95	22.90
<b>BOUDOIR SOFTWARE</b>				
The Naked Gamer	21.95	18.65	26.95	22.90
<b>ARIZIN</b>				
Toolkit (Great utility. Same one works on disk or tape)	29.95	25.45		
<b>COGNITEC</b>				
Telewriter-64 (New! The Best)	49.95	42.45	59.95	50.95

20% OFF!!!

MARK DATA (Close Out-Limited Quantities)				
Astro Blast	24.95	19.95	29.95	23.95*
Color Haywire	24.95	19.95	29.95	23.95*
Space Raiders	24.95	19.95	29.95	23.95*
Cave Hunter	24.95	19.95	29.95	23.95*
<b>TOM MIX</b>				
Bird Attack	21.95	17.55		
Maze Race	14.95	11.95		
Trek-16	19.95	15.95		
Fixer (Move those tape programs to disk)	18.95	15.15		

**PRICKLY PEAR - All Items 20% OFF**

HARDWARE

AZDS Drive 0 for Coco includes Rompack Interface				424.95
R/S Disk Drive Rompack Interface (Needs Cable)				149.95
Mark Data Professional Keyboard (Typewriter Style)				69.95
64 K Ram Chips	Set			64.95
Disk Cables		Two Drives	Four Drives	
Standard		24.95	34.95	
Gold Contacts-The Best		34.95	44.95	

THE COCO SWITCH BY COMPUTER INNOVATION

This first rate device lets you switch three different devices to your RS-232 Serial Port. A quality metal case and a 6 foot cable make this a special value.

Regular • 39.95      Special • 29.95

SOFTWARE AUTHORS: We are looking for product!! Send us your submissions!

TO ORDER

Add \$200 Postage and Handling. In Arizona, Add 5% Sales Tax. C.O.D. \$1.50 Extra To:

**ARIZONA DISCOUNT SOFTWARE**  
1942 S. Emerson #141 • Mesa, AZ 85202  
Phone (602) 897-6291

```

URIZER HEATER TRIPPED***";CHR$(5
);:PLAYA2$:NEXT:AF(3)=1
910 IFPW>100THENAF(3)=0
920 TH=TC+(CTP*.01*66):GOSUB1130
:GOSUB1140
930 IFOC(1)=0THENTH=TH+(CTP*.01*
66):GOSUB1130
940 IFOC(2)=0THENGW=GW-(T-ET(2)
)*2.4):ET(2)=T:GOSUB510ELSE960
950 IFAF(4)=0THENGOSUB1840:FORI=
1TO2:PLAYA1$:PRINT@480,"**SECOND
ARY FEEDWATER PUMP OFF**";CHR$(5
);:PLAYA2$:NEXT:AF(4)=1
960 IFOC(3)=1THENGW=FIX(GW+(T-E
T(3))*3.03):ET(3)=T:GOSUB510
970 IFOC(4)=1THEN980ELSE990
980 IFOC(5)=0THENPW=PW-(T-ET(5)
)*.4):VS=PV-(PW*5.3):ET(5)=T:GOS
UB430:GOSUB1130:TH=TH+1ELSEIFOC(
5)=1THENGOSUB730:PW=PW+(T-ET(4)
)*IV):VS=PV-(PW*5.3):ET(4)=T:GOS
UB430:GOSUB1130:TH=TH-1
990 IFOC(7)<>0THENP1=FIX(P1*EXP(
-(T-ET(7))/106.4)):ET(7)=T:GOSUB
1140
1000 IFOC(7)=1ANDP1<2205THENOC(7
)=0:GOSUB370:GOSUB1840:PRINT@480
,"Pressure Relief Valve CLOSED";
1010 IFOC(8)=1THENPR=TH/P1:TH=TH
-T+ET(8):ET(8)=T:P1=TH/PR:GOSUB1
140:GOSUB430
1020 IFOC(6)=1THENPR=TH/P1:TH=TH
+T-ET(6):ET(6)=T:P1=TH/PR:GOSUB1
140:GOSUB430
1030 A=RND(100):IFA=20ORA=40ORA=
60ORA=80THENONA/20 GOSUB1770,178
0,1790,1800
1040 GOSUB740
1050 IFPW>401THENPW=401ELSEIFPW=
<0THENPW=1:IFSV=1THEN1060ELSEGOS
UB630:SV=1
1060 IFSV=0THEN1070ELSEIFOC(1)=1
ANDOC(4)=1ANDOC(5)=1ANDPW>5THENS
V=0:GOSUB640
1070 IFGW<1THENGW=0
1080 FORI=0TO5:IFAF(I)=1THENX=X+
1:NEXTELSENEXT
1090 IFX<>0THENPRINT@0,CHR$(5);"
AL";CHR$(5);:X=0ELSEIFX=0THENPRI
NTCHR$(5);:PRINT@0,"":PRINTCHR
$(5);
1100 PT=(TC+TH)/2:IFPT=>705.2THE
NPAINT(31,112),4,4:GOSUB1830:PRI
NT@320,"***CRITICAL WATER TEMPER
ATURE*** ***SIMULATION OVER*
**":PLAYA3$ELSE1120
1110 IFINKEY$=""THEN1110ELSEPLAY
A3$:GOTO1820
1120 IFINKEY$=CHR$(12)ORPEEK(342
)=247THENRETURNELSE280

```



```

1130 P1=R*(TH+460)/VS:RETURN
1140 IFOC(4)=1ANDOC(5)=1ANDPW<10
THENGOSUB730:PW=PW+(T-ET(4))*IV
):VS=PV-(PW*5.3):ET(4)=T:GOSUB42
0:GOSUB1120:TH=TH-1:RETURNELSEVS
=R*(TH+460)/P1:PW=(PV-VS)/5.3:GO
SUB430:RETURN
1150 TH=(P1*VS/R)-460:RETURN
1160 CLS:PRINT@172,"WARNING":PRI
NT@227,"NUCLEAR REACTOR SIMULATO
R-":PRINT@258,"CONTENTS MAY BE R
ADIOACTIVE!":PRINT@291,"PROCEED
AT YOUR OWN RISK!":PRINT@362,"aL
ARM CANCEL":PRINT@390,"cONTINUE
SIMULATION"
1170 FORI=1TO250:NEXT:IFINKEY$="
A"THEN1190
1180 PRINT@172,"warning":PLAYA1$
:PRINT@172,"WARNING":PLAYA2$: IFP
EEK(339)=254THEN1190ELSEIFPEEK(3
41)=254THEN1200ELSE1180
1190 IFINKEY$<>"C"THEN1190
1200 CLS:PRINT@98,"NUCLEAR REACT
OR SIMULATOR:":PRINT@160,"OBJECT
:PRODUCE 97%+ ELECTRIC":PRINTTAB
(7)"POWER":PRINT@224,"OBJECT:MAI
NTAIN PRIMARY LOOP":PRINTTAB(7)"
TEMPERATURE @ 580 DEG F":PRINT@2
88,"OBJECT:MAINTAIN PRIMARY LOOP
"
1210 PRINTTAB(7)"PRESSURE @ 2155
PSI":PRINT@352,"OBJECT:MAINTAIN
PRESSURIZER":PRINTTAB(7)"WATER
LEVEL @ 200 IN":PRINT@455,"rEADY
?"
1220 IFINKEY$<>"R"THEN1220
1230 CLS:PRINT@98,"NUCLEAR REACT
OR SIMULATOR:":PRINT@160,"OBJECT
:MAINTAIN SECONDARY LOOP":PRINTT
AB(7)"TEMPERATURE @ 547 DEG F":P
RINT@224,"OBJECT:MAINTAIN SECOND
ARY LOOP":PRINTTAB(7)"PRESSURE @
1010 PSI"
1240 PRINT@288,"OBJECT:MAINTAIN
STEAM GENERATOR":PRINTTAB(7)"WAT
ER LEVEL @ 288 IN":PRINT@455,"rE
ADY?"
1250 IFINKEY$<>"R"THEN1250
1260 CLS:PRINT@66,"NUCLEAR REACT
OR SIMULATOR:":PRINT@128,"CONTRO
L RODS:RAISE & LOWER WITH":PRINT
TAB(8)"ARROW KEYS":PRINT@192,"PU
MPS:SPECIFY PUMP BY NUMBER &":PR
INTTAB(8)"DIRECTIVE. EX. 'P1ON'"
1270 PRINT@256,"VALVES:SPECIFY V
ALVE BY NUMBER":PRINTTAB(8)"& DI
RECTIVE":PRINTTAB(8)"EX. 'V1OPEN
'":PRINT@352,"PRESSURIZER WATER
HEATER:":PRINTTAB(8)"SPECIFY DIR
ECTIVE":PRINTTAB(8)"EX. 'HEATON'

```

## Utilities For Extended Basic

- #UK3 COLOR KRUNCHER — \$12.95**  
--Reduces Memory Requirements Of any Extended Basic Program-Speeds Program Execution Time  
--Type In A Program From A Magazine, As Is, Debug It Then Let KRUNCHER Make It Shorter  
--Includes LN,XREF and REM,REMV (#UR2)  
--Includes 'EXTENDED BASIC FASTER' (#F1)
- #F1 'EXTENDED BASIC FASTER' — \$3.95**  
--The First Published Proven List Of Methods You Can Incorporate Into All Your Own Ext. BASIC Programs For Maximum Speed Efficiency  
--For Novice or Experienced Programmer  
--For Graphics or Non-Graphic Programs
- #UVF4 VARIABLE CROSS REFERENCE — \$6.95**  
--Locate All Variables And 'Where Used' Line #'s In Your Extended BASIC Program  
--Automatic Sort — Optional Printer Output
- #UF3 LLIST FORMATTER — \$9.95**  
--User-selectable Margins, Page Lengths, Top-of-Form, Font Size, Line Length and More  
--Title and Date Your Important Listings  
--Optional Space Between Lines—Highlights Line Numbers— For Most Recent Printers (can be user modified)
- #UR2 LINE CROSS REFERENCE — \$7.95**  
--Provides A Sorted Listing Of Referenced Line Numbers Optional Printer Output  
--Includes Optional REM,REMV—Removes All Unreferenced REM's and Comments  
--Removes Comments From Referenced REM's
- #UD2 DISK DIRECTORY WITH BYTES — \$7.95**  
--Gives Same Info As DIR, PLUS Individual File Bytes, PLUS Free and Used # of Files, Grans, and Bytes, PLUS Optional Disk Name,PLUS To Screen OR Printer  
--One Screen At A Time (No More Frantic SFT/a)
- #US2 COPY, SEARCH & REPLACE — \$7.95**  
--Same as Disk COPY, But to-and-from Disk and Tape or Tape and Tape  
--For ASCII Textfiles Or Programs  
--Search OR Search & Replace  
--Excellent For Changing Long Variable Names  
--Great For Changing Spelling Or Capitalization
- #UT2 TEXT COUNT — \$6.95**  
--Counts Lines, Sentences, Words, Total Characters Of An ASCII Extended BASIC Textfile
- #UB2 BYTE/LINE COUNT — \$5.95**  
--Automatic, Accurate Byte & Line Count Of Any Extended BASIC Program

ALL PGMS (EXCEPT #UD2) FOR EXT. BASIC TAPE/DISK

Buy Two or More On The Same Order & Take 10% Off  
(Postpaid in U.S. & Canada) (PA Residents Add 6%)

Send Check or Money Order To:  
**MICROLOGIC**  
Box 193, 1st. Avenue  
East Brady, Pa. 16028 (412-526-5781)

```

":PRINT@456,"READY?";
1280 IFINKEY$<>"R"THEN1280
1290 PL=200:CLS:PRINT@261,"SIMUL
ATION BEGINS.....":A=USR0(0):GOS
UB80:PLAYA3$
1300 GOSUB1830:GOTO1690
1310 GOSUB1830
1320 PRINT@320,,:GOTO1340
1330 GOSUB1840:PRINT@480,,:
1340 PRINT"Directive?";:GOSUB690
:D$=AT$:IFD$="TC"THEN1450ELSEIFD
$="PRINT"THEN1460
1350 FORI=0TO21:IFD$=V1$(I)THEN0
C=I:GOTO1380
1360 NEXT
1370 PRINT@480,"Directive?INVALI
D DIRECTIVE      ";:FORI=1TO2:PLA
Y"L7V3101CP10":NEXT:PRINT@490,"
      ":PRINT@480,,:GO
TO1340
1380 ON OC+1GOTO1390,1540,1550,1
560,1570,1580,1590,1600,1600,163
0,1640,1660,1670,1680,1710,1720,
1690,1750,1860,1730,1820,1810
1390 GOSUB1840:PRINT@480,"Contro
l Rods-Manual Control";
1400 PRINT@320,USING"Core Therma
l Power      ### %      ";CTP
1410 IFPEEK(341)=247THENCTP=CTP+
1:GOSUB1420:GOTO1400ELSEIFPEEK(3
42)=247THENCTP=CTP-1:GOSUB1420:G
OTO1400ELSEA$=INKEY$:IFA$=CHR$(1
2)THENGOSUB1840:RETURNELSE1410
1420 IFCTP<0THENCTP=0ELSEIFCTP>1
00THENCTP=100
1430 IFCTP>7THENAF(0)=0
1440 GOSUB230:RETURN
1450 TC$="":FORI=1TO8:TC$=TC$+ST
R$(OC(I)):NEXT:PRINT@480,TC$,:RE
TURN
1460 A=USR1(0):A$="":PMODE4,1:PR
INT#-2,CHR$(18);CHR$(13);
1470 FORI=0TO6:P(I)=FIX(2^I):NEX
TI
1480 FORI=0TO118STEP7:FORJ=0TO25
5:A=128:FORK=0TO6
1490 IFPOINT(J,I+K)=0THENA=A+P(K)
1500 NEXTK
1510 IFJ<200THENA$=A$+CHR$(A)ELS
EB$=B$+CHR$(A)
1520 IFJ=255THENPRINT#-2,A$;B$;C
HR$(13);:A$="":B$=""
1530 NEXTJ,I:GOTO1820
1540 OC(1)=1:GOSUB1840:PRINT@480
,"Reactor Coolant Pump ON";:RETU
RN
1550 OC(1)=0:GOSUB1840:PRINT@480
,"Reactor Coolant Pump OFF";:RET
URN

```

```

1560 OC(2)=1:AF(4)=0:GOSUB1840:P
RINT@480,"Secondary Feedwater Pu
mp ON";:RETURN
1570 OC(2)=0:AF(4)=1:GOSUB1850:G
OSUB1840:PRINT@480,"Secondary Fe
edwater Pump OFF";:ET(2)=T:RETUR
N
1580 OC(3)=1:GOSUB1840:PRINT@480
,"Auxiliary Makeup Pump ON";:GOS
UB620:ET(3)=T:RETURN
1590 OC(3)=0:GOSUB1840:PRINT@480
,"Auxiliary Makeup Pump OFF";:GO
SUB620:RETURN
1600 GOSUB1840:OC(4)=1:EM(3)=0:I
FD$="P4IN"THENO(5)=1:GOSUB590EL
SEIFD$="P4OUT"THENO(5)=0:GOSUB5
90
1610 IFO(5)=1THENET(4)=T:GOSUB1
840:PRINT@480,"Primary Makeup Pu
mp ON";:RETURN
1620 IFO(5)=0THENET(5)=T:GOSUB1
840:PRINT@480,"Primary Let-down
Pump ON";:RETURN
1630 GOSUB1840:OC(4)=0:EM(3)=0:G
OSUB590:IFOC(5)=1THENPRINT@480,"
Primary Makeup Pump OFF";:OC(5)=
0:RETURNELSEPRINT@480,"Primary L
et-down Pump OFF";:RETURN
1640 OC(6)=1:ET(6)=T:GOSUB1840:I
FPW<100THEN1650ELSEPRINT@480,"Pr
essurizer Heater ON";:GOSUB490:R
ETURN
1650 OC(6)=0:PRINT@480,"Pressuri
zer Heater TRIPPED";:GOSUB490:RE
TURN
1660 OC(6)=0:GOSUB1840:PRINT@480
,"Pressurizer Heater OFF";:GOSUB
490:RETURN
1670 OC(7)=2:ET(7)=T:AF(1)=1:GOS
UB1840:PRINT@480,"Pressure Relie
f Valve OPEN";:GOSUB370:RETURN
1680 OC(7)=0:AF(1)=0:GOSUB1840:P
RINT@480,"Pressure Relief Valve
CLOSED";:GOSUB370:RETURN
1690 GOSUB720:PRINT@320,USING"Co
re Thermal Power      #### MWth";(
CTP*.01*3411):PRINTUSING"Primary
Loop Press      #### PSI";P1:PRIN
TUSING"Primary Loop Temp      ###
# DEG";PT:PRINTUSING"Pressurizer
Level      ### IN";PW
1700 GOSUB750:IFINKEY$=CHR$(12)O
RPEEK(342)=247THENGOSUB1330:GOTO
1690ELSE1690
1710 GOSUB1840:OC(8)=1:ET(8)=T:P
RINT@480,"Pressurizer Coolant Sp
ray ON";:GOSUB400:RETURN
1720 GOSUB1840:OC(8)=0:PRINT@480
,"Pressurizer Coolant Spray OFF"
;:GOSUB400:RETURN

```

# COLOR COMPUTER NEW!

## MACRO-80C

The Micro Works is pleased to announce the release of its **disk-based editor, macro assembler and monitor**, written for Color Computer by Andy Phelps. THIS IS IT — The ultimate programming tool!

The powerful 2-pass macro assembler features conditional assembly, local labels, include files and cross referenced symbol tables. MACRO-80C supports the complete Motorola 6809 instruction set in standard source format. There are no changes, constraints or shortcuts in the source language definition. Incorporating all of the features of our Rompack-based assembler (SDS80C), MACRO-80C contains many more useful instructions and pseudo-ops which aid the programmer and add power and flexibility.

The screen-oriented text editor is designed for efficient and easy editing of assembly language programs. The "Help Key" feature makes it simple and fun to learn to use the editor. As the editor requires no line numbers, you can use the arrow keys to position the cursor anywhere in the file. MACRO-80C allows global changes and moving/copying blocks of text. You can edit lines of assembly source which are longer than 32 characters.

DCBUG is a machine language monitor which allows examining and altering of memory, setting break points, etc.

The editor, assembler and monitor — as well as sample programs — come on one Radio Shack compatible disk. Extensive documentation included. **MACRO-80C Price: \$99.95**

## YOU NEED COLOR FORTH!!

Why?

- Forth is faster to program in than Basic
- Forth is easier to learn than Assembly Language
- Forth executes in less time than Basic

Forth is a highly interactive language like Basic, with structure like Pascal and execution speed close to that of Assembly Language. The Micro Works Color Forth is a Rompack containing everything you need to run Forth on your Color Computer.

Color Forth consists of the standard FORTH Interest Group (FIG) implementation of the language plus most of FORTH-79. It has a super screen editor with split screen display. Mass storage is on cassette. Color Forth also contains a decompiler and other aids for learning the inner workings of this fascinating language. It will run on 4K, 16K, and 32K computers. Color Forth contains 10K of ROM, leaving *your* RAM for *your* programs! There are simple words to effectively use the Hi-Res Color Computer graphics, joysticks, and sound. The 112-page manual includes a glossary of the system-specific words, a full standard FIG glossary and complete source listing. **COLOR FORTH... THE BEST!** From the leader in Forth, Talbot Microsystems. **Price: \$109.95**

## SOFTWARE DEVELOPMENT SYSTEM

The Micro Works Software Development System (SDS80C) is a complete 6809 editor, assembler and monitor package contained in one Color Computer program pack! Vastly superior to RAM-based assemblers/editors, the SDS80C is non-volatile, meaning that if your application program bombs, it can't destroy your editor/assembler. Plus it leaves almost all of 16K or 32K RAM free for *your* program. Since all three programs, editor, assembler and monitor are co-resident, we eliminate tedious program loading when going back and forth from editing to assembly and debugging!

The powerful screen-oriented Editor features finds, changes, moves, copies and much more. All keys have convenient auto repeat (typamatic), and since no line numbers are required, the full width of the screen may be used to generate well commented code.

The Assembler features all of the following: complete 6809 instruction set; conditional assembly; local labels; assembly to cassette tape or to memory; listing to screen or printer; and mnemonic error codes instead of numbers.

The versatile monitor is tailored for debugging programs generated by the Assembler and Editor. It features examine/change of memory or registers, cassette load and save, breakpoints and more. **SDS80C Price: \$89.95**

## MICROTEXT: COMMUNICATIONS VIA YOUR MODEM!

Now you can use your printer with your modem! Your computer can be an intelligent printing terminal. Talk to timeshare services or to other personal computers; print simultaneously through a second printer port and re-display text stored in memory. Dump to a cassette tape, or printer, or both. Microtext can be used with any printer or no printer at all. It features user-configurable duplex/parity for special applications, and can send any ASCII character. You'll find many uses for this general purpose module! Microtext is available in ROMPACK, ready-to-use, for **\$59.95**.

**PARALLEL PRINTER INTERFACE** — Serial to parallel converter allows use of all standard parallel printers. P180C plugs into the serial output port, leaving your Rompack slot free. You supply the printer cable. **P180C Price: \$69.95**

## GAMES

**Star Blaster** — Blast your way through an asteroid field in this action-packed Hi-Res graphics game. Available in ROMPACK; requires 16K. **Price: \$39.95**

**Pac Attack** — Try your hand at this challenging game by Computerware, with fantastic graphics, sound and action! Cassette requires 16K. **Price: \$24.95**

**Berserk** — Have fun zapping robots with this Hi-Res game by Mark Data Products. Cassette requires 16K. **Price: \$24.95**

**Adventure** — *Black Sanctum* and *Calixto Island* by Mark Data Products. Each cassette requires 16K. **Price: \$19.95** each.

**Cave Hunter** — Experience vivid colors, bizarre sounds and eerie creatures in hot pursuit as you wind your way through a cave maze in search of gold treasures. This exciting Hi-Res game by Mark Data Products requires 16K for cassette version. **Price: \$24.95**

**Also Available:** Machine Language Monitor ★ 2-Pass Disassembler ★ Memory Upgrade Kits ★ We Stock 64K Chips  
★ Parts and Services ★ Books ★ Call or write for information

THE MICRO  
WORKS



**GOOD STUFF!**

P.O. BOX 1110, DEL MAR, CA 92014 [619] 942-2400

MasterCharge/Visa Accepted  
California residents add 6% tax.



# compu•sette®

## TAPES & DISKS

100% ERROR-FREE  
FULLY GUARANTEED



**C-10's**  
**39¢ ea.**  
(min. lot of 500)  
w/ labels add 4¢  
w/ boxes add 13¢

Compu•sette, a product of MICRO-80 INC

The Micro-Trac™ Generation

Used by Software Firms & Computer Hobbyists  
Choice of School Districts Nationwide

CASSETTES	MINI	STANDARD
	12-PAK	24-PAK
C-05 .....	\$ .79	\$ .59
C-10 .....	\$ .89	\$ .69
C-20 .....	\$ .99	\$ .89
C-30 .....	\$1.29	\$1.09
Custom Cases .....	\$ .26	\$ .21

Cases recommended to protect sensitive cassettes.

5¼" DISKETTES	MINI	STANDARD
	5-PAK	10-PAK*
Soft Sector		
Single Sided		
S/D Density .....	\$14.95	\$26.95

\*10 PAK w/custom library case, add \$3.00

— UPS SHIPPING —

(No. P.O. Boxes please)

\$3.00 per pack

— Canadian shipping multiply by 2 —

**No. 1 Magnetic Media in the USA!**

— Write for volume prices —

TOLL-FREE  
(orders only)

1-800-528-6050

ext. 3005

In Arizona State

1-800-352-0458

ext. 3005

# MICRO-80™ INC.

E. 2665 Busby Road  
Oak Harbor, WA 98277  
1 (206) 675-6143



```
1730 GOSUB1830:PRINT@320,;:FORI=
0T020:PRINTV1$(I)":":;:NEXT:PRINT
"EXIT";
```

```
1740 IFPEEK(342)<>247THENGOSUB75
0:GOSUB720:GOTO1740ELSEGOSUB1830
:RETURN
```

```
1750 GOSUB720:GOSUB680:PRINT@320
,USING"Plant Electric Output ###
# MWe ";PO:PRINTUSING"Secondary
Loop Press #### PSI";SP:PRINTUS
ING"Secondary Loop Temp #### D
EG";ST:PRINTUSING"Steam Gen Wate
r Level ### IN";GW
```

```
1760 GOSUB750: IFPEEK(342)=247ORI
NKEY$=CHR$(12) THENGOSUB1330:GOTO
1750ELSE1750
```

```
1770 OC(7)=2:ET(7)=T:AF(1)=1:GOS
UB370:RETURN
```

```
1780 OC(2)=0:ET(2)=T:RETURN
```

```
1790 IFOC(4)<>1THENEM(3)=1:ET(9)
=T:COLORC1:DRAW"BM255,111L22D1R2
2":COLOR4:RETURNELSERETURN
```

```
1800 RETURN
```

```
1810 A=USR1(0):PW(2)=1000:GW(2)=
1000:GOTO1200
```

```
1820 A=USR1(0):CLS:PRINT@128,;:L
IST1:END
```

```
1830 PRINT@320,STRING$(192," "):
RETURN
```

```
1840 PRINT@480,STRING$(32," "):;
RETURN
```

```
1850 EM(3)=0:RETURN
```

```
1860 GOSUB1830:PRINT@320,;:FURI=
0T05:IFAF(I)=1THENPRINT"*"AL$(I)
:NEXT:GOTO1740ELSENEXT:GOTO1740
```

## About Your Subscription

Your copy of *the RAINBOW* is sent third class mail and, for subscribers in the United States, the date of mailing is printed on the label. If you do not receive your copy by the 25th of any month, send us a card and we will mail another immediately via first class mail.

You must notify us of a new address when you move. Notification should reach us no later than the 15th of the month prior to the month in which you change your address. Sorry, we cannot be responsible for sending another copy when you fail to notify us.

Your mailing label also shows an "account number" and the subscription expiration date. Please indicate this account number when renewing or corresponding with us. It will help us help you better and faster.

For Canadian and other non-U.S. subscribers, there may be a mailing address shown that is different from our editorial office address. Do not send any correspondence to that mailing address. Send it to our editorial offices at P.O. Box 209, Prospect, KY 40059. This applies to everyone *except* those whose subscriptions are through our distributor in Australia.

0001 0600

NAM HIRESTXT

0052 0076 7EADA5

JMP \$ADA5 CLEAR THE

\* THIS PROGRAM IS TO BE USED  
\* WITH NUKE SIM - THE NUCLEAR  
\* REACTOR SIMULATOR.

\* INTERRUPT MASKS. THEN JUMP TO  
\* THE AREA OF BASIC THAT RUNS  
\* THE PROGRAM, BYPASSING THE  
\* BREAK CHECK ROUTINE.

0002 0600

ORG 0000 MAKE IT PIC

0053 0079 3436

HRSTXT PSHS D,X,Y

0003 0000 6D8C31

START TST <TOGLE,PCR NOT 0

0054 007B 8108

CMPA #8 BACKSPACE?

0004 0003 261B

BNE B@ NOT ON

0055 007D 10270099

LBEQ BACKSP YES THEN GO

0005 0005 6C8C2C

INC <TOGLE,PCR FOR RESET

0056 0081 8105

CMPA #5 INV. CHARS?

0006 0008 BE0168

LDX \$168 GET HOOK

0057 0083 260A

BNE ALPHA NO THEN CHR

0007 000B AF8C27

STX <VEC,PCR SAVE IT

0058 0085 E68CAF

LDB INVERT,PCR FLIP INVERT

0008 000E 308C68

LEAX <HRSTXT,PCR NEW HOOK

0059 0088 C801

EORB #1 FLAG THEN

0009 0011 BF0168

STX \$168 STORE IT

0060 008A E78CAA

STB INVERT,PCR RETURN

0010 0014 BE019B

LDX \$19B GET HOOK

0061 008D 201A

BRA RET

0011 0017 AF8C1E

STX <BRKVEC,PCR SAVE IT

0062 008F C63F

ALPHA LDB #63 NUMBER

0012 001A 308C1D

LEAX <BRKCLR,PCR NEW HOOK

0063 0091 318D0093

\* OF CHARACTERS USED BY NUKE SIM  
LEAY LETTA,PCR FIRST LETT

0013 001D BF019B

A@ STX \$19B STORE IT

0064 0095 A1A0

A@ CMPA ,Y+ ASCII

0014 0020 39

B@ RTS TO BASIC

0065 0097 2730

B@ BEQ FOUND GOT IT?

0015 0021 6D8C10

RESET TST <TOGLE,PCR NOT 1

0066 0099 3127

LEAY 7,Y NO, NEXT

0016 0024 27FA

BEQ B@ NO RESET

0067 009B 5A

DECB ALL 63?

0017 0026 6F8C0B

CLR <TOGLE,PCR FOR SET

0068 009C 26F7

BNE A@ NO, NEXT

0018 0029 AE8C09

LDX <VEC,PCR GET OLD VEC

0069 009E C605

LDB #5 5 DESCENDER

0019 002C BF0168

STX \$168 RESTOR HOOK

0070 00A0 A1A0

B@ CMPA ,Y+ ASCII

0020 002F AE8C06

LDX <BRKVEC,PCR SAME AS

0071 00A2 2707

BEQ DESCEN GOT IT?

0021 0032 20E9

BRA A@ ABOVE STEPS

0072 00A4 3127

LEAY 7,Y NO, NEXT

0022 0034 00

TOGGLE FCB 0

0073 00A6 5A

DECB ALL DONE?

0023 0035 0000

VEC FDB 0

0074 00A7 26F7

BNE B@ TRY NEXT

0024 0037 01

INVERT FCB 1

0075 00A9 35B6

RET PULS D,X,Y,PC TO BASIC

0025 0038 0000

BRKVEC FDB 0

0026 003A 3407

BRKCLR PSHS A,B,CC

0076 00AB 8D22

DESCEN BSR FNDLOC

0027 003C F60155

LDB 341 THE PROGRAM

0077 00AD C605

LDB #5 5 BLANKS

0028 003F 86F7

LDA #247 NEEDS THE

0078 00AF E78D0039

STB DRCHAR+1,PCR CHANGE PROG

0029 0041 B7FF02

STA \$FF02 ARROW KEYS

0079 00B3 C639

LDB #39 RTS CODE

0030 0044 B6FF00

LDA \$FF00 BUT WITH

0080 00B5 E78D005B

STB BOT,PCR PUT IN STA

0031 0047 8A80

ORA #128 BREAK DIS-

0081 00B9 8D30

BSR DRCHAR GO DRAW IT

0032 0049 81F7

CMPA #247 ABLE THE

0082 00BB C603

LDB #3 RESTORE

0033 004B 2704

BEQ B@ AREA WHERE

0083 00BD E78D002B

STB DRCHAR+1,PCR PROGRAM

0034 004D CA08

ORB #8 THE KEYS

0084 00C1 C6A7

LDB #A7 STA CODE

0035 004F 2002

BRA C@ ARE READ IS

0085 00C3 E78D004D

STB BOT,PCR CHANGE RTS

0036 0051 C4F7

B@ ANDB #247 NOT UP-

0086 00C7 20E0

BRA RET GOTO BASIC

0037 0053 F70155

C@ STB 341 SO IT IS

0087 00C9 8D04

FOUND BSR FNDLOC

0038 0056 F60156

LDB 342 DONE HERE.

0088 00CB 8D1E

BSR DRCHAR DRAW IT

0039 0059 86EF

LDA #239 TO UNDER-

0089 00CD 20DA

BRA RET RETURN

0040 005B B7FF02

STA \$FF02 STAND HOW

0090 00CF DC88

FNDLOC LDD <\$88

0041 005E B6FF00

LDA \$FF00 THIS WORKS

0091 00D1 3404

\* CURSOR POSITION KEPT BY BASIC  
PSHS B SAVE 0-31

0042 0061 8A80

ORA #128 READ PAGE

0092 00D3 44

LSRA MOVE BIT 0

0043 0063 81F7

CMPA #247 33 OF THE

0093 00D4 56

RORB INTO B REG

0044 0065 2704

BEQ D@ COLOR

0094 00D5 54

LSRB NOW MOVE

0045 0067 CA08

ORB #8 COMPUTER

0095 00D6 54

LSRB INTO LOWER

0046 0069 2002

BRA E@ TECHNICAL

0096 00D7 54

LSRB NYBBLE OF B

0047 006B C4F7

D@ ANDB #247 REFERENCE

0097 00D8 54

LSRB REGISTER

0048 006D F70156

E@ STB 342 MANUAL.

0098 00D9 860C

LDA #12 12 LINES

0049 0070 3507

PULS A,B,CC RESTORE REG

0099 00DB 3D

MUL PER CHAR.

0050 0072 3262

LEAS 2,S PULL RETURN

0100 00DC 8620

LDA #32 32 BYTES

0051 0074 1CAF

ANDCC #AF ADDRESS AND

0101 00DE 3D

MUL WIDE.

0102 00DF 1F01	TFR D,X	TO X	0144 0146 6C78	FCB 108,120
0103 00E1 3504	PULS B	NOW GET		
0104 00E3 C41F	ANDB #31	POSITION	0145 0148 457E60607C E	FCB #45,126,96,96,124,96,96
0105 00E5 3A	ABX	ACROSS	0146 014F 7E	FCB 126
0106 00E6 DCBC	LDD <#BC	START OF HI		
0107 00E8 308B	LEAX D,X	RES SCREEN	0147 0150 467E60607C F	FCB #46,126,96,96,124,96,96
0108 00EA 39	RTS	ALL DONE	0148 0157 60	FCB 96
	* CHARACTERS WITHOUT DESCENDERS		0149 0158 473C666060 G	FCB #47,60,102,96,96,110,102
	* ARE MADE UP OF 3 BLANK ROWS,		0150 015F 3C	FCB 60
	* 7 DATA ROWS, 2 BLANK ROWS.			
	* DESCENDERS ARE 5 AND 7		0151 0160 486666667E H	FCB #48,102,102,102,126,102
0109 00EB C603	DRCHAR LDB #3		0152 0166 6666	FCB 102,102
0110 00ED 4F	CLRA	ABOVE CHAR		
0111 00EE 6D8DFF45	TST INVERT,PCR	WHICH COLOR	0153 0168 493C181818 I	FCB #49,60,24,24,24,24,24,60
0112 00F2 2701	BEQ C0	0 = W ON B		
0113 00F4 43	COMA	FLIP B ON W	0154 0170 4A06060606 J	FCB #4A,6,6,6,6,6,102,60
0114 00F5 3402	C0 PSHS A	SAV AWILE		
0115 00F7 A784	D0 STA ,X	ON SCREEN	0155 0178 4B66666C78 K	FCB #4B,102,102,108,120,108
0116 00F9 308820	LEAX 32,X	NEXT ROW	0156 017E 6666	FCB 102,102
0117 00FC 5A	DECB	ALL DONE?		
0118 00FD 26F8	BNE D0	NO, NEXT	0157 0180 4C60606060 L	FCB #4C,96,96,96,96,96,96,126
0119 00FF C607	LDB #7	7 ROWS TALL		
0120 0101 A6A0	NXTBYT LDA ,Y+	DATA	0158 0188 4D667E7E66 M	FCB #4D,102,126,126,102,102
0121 0103 6D8DFF30	TST INVERT,PCR	CHECK COLOR	0159 018E 6666	FCB 102,102
0122 0107 2701	BEQ E0	0 = W ON B		
0123 0109 43	COMA	B ON W	0160 0190 4E66767E7E N	FCB #4E,102,118,126,126,110
0124 010A A784	E0 STA ,X	TO SCREEN	0161 0196 6666	FCB 102,102
0125 010C 308820	LEAX 32,X	NEXT ROW		
0126 010F 5A	DECB	ALL ??	0162 0198 4F3C666666 O	FCB #4F,60,102,102,102,102,102
0127 0110 26EF	BNE NXTBYT	NEXT BYTE	0163 019F 3C	FCB 60
0128 0112 3502	PULS A	RETRIEVE A		
0129 0114 A784	BOT STA ,X	BOTTOM 2	0164 01A0 507C66667C P	FCB #50,124,102,102,124,96,96
0130 0116 A78820	STA 32,X	ROWS ALSO	0165 01A7 60	FCB 96
0131 0119 39	RTS	ALL DONE		
			0166 01A8 513C666666 Q	FCB #51,60,102,102,102,118,108
0132 011A 17FFB2	BACKSP LBSR FNDLOC	WHERE	0167 01AF 3A	FCB 58
0133 011D 301F	LEAX -1,X	BACKSPACE		
0134 011F 318D01CE	LEAY SPACE+1,PCR	BLANK CHAR	0168 01B0 527C66667C R	FCB #52,124,102,102,124,108
0135 0123 8DC6	BSR DRCHAR	PUT IT ON	0169 01B6 6666	FCB 102,102
0136 0125 16FF81	LBRA RET	DONE		
			0170 01B8 533C66603C S	FCB #53,60,102,96,60,6,102,60
	* NOT ALL LETTERS ARE INCLUDED		0171 01C0 547E181818 T	FCB #54,126,24,24,24,24,24,24
	* HERE, ONLY THOSE THAT ARE USED			
	* IN THE BASIC PROGRAM .		0172 01C8 5566666666 U	FCB #55,102,102,102,102,102
	* EACH CHARACTER IS SEVEN ROWS		0173 01CE 663C	FCB 102,60
	* TALL. THE HEX NUMBER IS THE			
	* ASCII CODE FOR THE COMPARE		0174 01D0 5666666666 V	FCB #56,102,102,102,102,102
	* USED TO FIND EACH DATA BLOCK		0175 01D6 3C18	FCB 60,24
0137 0128 41183C6666	LETTA	FCB #41,24,60,102,102		
0138 012D 7E6666		FCB 126,102,102	0176 01D8 5766666666 W	FCB #57,102,102,102,102,126
			0177 01DE 7E66	FCB 126,102
0139 0130 427C66667C	B	FCB #42,124,102,102,124,102		
0140 0136 667C		FCB 102,124	0178 01E0 5866663C18 X	FCB #58,102,102,60,24,60,102
			0179 01E7 66	FCB 102
0141 0138 433C666060	C	FCB #43,60,102,96,96,96,102		
0142 013F 3C		FCB 60	0180 01E8 5966663C18 Y	FCB #59,102,102,60,24,24,24
			0181 01EF 18	FCB 24
0143 0140 44786C6666	D	FCB #44,120,108,102,102,102		



# AUTO RUN

SEE YOU AT  
RAINBOWFEST!

Auto Run is a utility program for the TRS-80\* Extended Basic Color Computer. It is used to add convenience and professionalism to your software.

Auto Run will help you create your title screen with the graphics editor. The graphics editor allows you to choose a background color and border style. Using the arrow keys and several other commands you can draw pictures, block letters and also include text.

Auto Run will generate a machine language loader program to precede your program on the tape. Then, to start up your program, simply type CLOADM to load in the Auto Run loader program, which will then automatically start itself up, display your title screen, load your program and then RUN or EXEC it.

Also you may record a vocal or musical introduction preceding your program. The Auto Run loader will control the audio on/off.

Basic programs can be set to load anywhere in memory above \$600 (the PCLEAR 0 page).

Software authors: The Auto Run prefix may be appended to your software products.

Auto Run is \$14.95 and includes complete documentation and an assembly source listing. Requires 16K Extended Basic.

## Galactic Hangman



A great new twist to the popular, educational word guessing game for the Color Computer. Large (700 words) and sophisticated vocabulary. Or enter your own words, your child's spelling list, foreign language vocabulary, etc.

Outstanding high resolution graphics, animation and sound effects.

For \$14.95 you get both the 16K and 32K versions of Galactic Hangman.



\*TRS-80 is a trademark of Tandy Corp.

**SUGAR SOFTWARE**  
2153 Leah Lane  
Reynoldsburg, Ohio 43068  
(614) 861-0565

CIS orders EMAIL to 70405, 1374

## Tape Information Management System

A user-oriented, easy to use personal database management system for the TRS-80\* Color Computer with these outstanding features:

- \* keeps files of programs, names, addresses, birthdays, recipes, class or club rosters, anything
- \* variable record and field lengths
- \* phrase substitution editor
- \* up to 8 user-definable fields
- \* ML sort (up to 3 fields), search and delete functions
- \* 2 search modes — range and item
- \* user-definable printer format, for any printer
- \* up to 230 characters per record

For \$24.95 you get the database management system, our full documentation which includes a reference guide and a programmer's guide, and our 1981 Bibliography of articles relating to the Color Computer. Requires 16K Extended Basic. 32K recommended.

1982 TIMS Bibliography — \$9.95

## Silly Syntax



A sensational and educational version of a popular party game for the TRS-80\* Color Computer . . .

For 1 to 10 players. Load a story into the computer. The players are asked to supply a noun, verb, part of body, celebrity, etc. which the program uses to complete the story. The story, which is displayed when all words are entered, will be hilarious. Silly Syntax requires 16K Extended Basic (32K for disk version). For \$19.95, you get a user guide and a tape containing the Silly Syntax game and 2 stories. You can create your own stories or order story tapes from the selection below.

**Silly Syntax stories — Ten stories per tape.**

- |                      |                           |
|----------------------|---------------------------|
| SS-001 - Fairy Tales | SS-004 - Current Events   |
| SS-002 - Sing Along  | SS-006 - Adventure/Sci-Fi |
| SS-003 - X-Rated     | SS-007 - Potpourri        |

Each story tape is \$9.95. 10% off for 3 or more story tapes. Disk is \$24.95 for Silly Syntax and 2 stories or \$49.95 for Silly Syntax and all 62 stories.

Add \$1.00 per tape or disk for postage and handling. Ohioans add 5.5% sales tax. COD orders are welcome. Dealer inquiries invited.

0182 01F0 5A7E060C18 Z	FCB \$5A,126,6,12,24,48,96,126	0217 02B8 333C66061C N3	FCB \$33,60,102,6,28,6,102,60
0183 01F8 6100003C06 LA	FCB \$61,0,0,60,6,62,102,62	0218 02C0 340E1E3666 N4	FCB \$34,14,30,54,102,126,6,6
0184 0200 6260607C66 LB	FCB \$62,96,96,124,102,102,102	0219 02C8 357E607C06 N5	FCB \$35,126,96,124,6,6,102
0185 0207 7C	FCB 124	0220 02CF 3C	FCB 60
0186 0208 6300003C66 LC	FCB \$63,0,0,60,102,96,102,60	0221 02D0 363C66607C N6	FCB \$36,60,102,96,124,102,102
0187 0210 6406063E66 LD	FCB \$64,6,6,62,102,102,102,62	0222 02D7 3C	FCB 60
0188 0218 6500003C66 LE	FCB \$65,0,0,60,102,126,96,60	0223 02D8 377E06060C N7	FCB \$37,126,6,6,12,24,48,96
0189 0220 663C666078 LF	FCB \$66,60,102,96,120,96,96	0224 02E0 383C66663C N8	FCB \$38,60,102,102,60,102,102
0190 0227 60	FCB 96	0225 02E7 3C	FCB 60
0191 0228 6860607C66 LH	FCB \$68,96,96,124,102,102,102	0226 02E8 393C66663E N9	FCB \$39,60,102,102,62,6,102
0192 022F 66	FCB 102	0227 02EF 3C	FCB 60
0193 0230 6918001818 LI	FCB \$69,24,0,24,24,24,24,24	0228 02F0 2000000000 SPACE	FCB \$20,0,0,0,0,0,0,0
0194 0238 6860666C78 LK	FCB \$68,96,102,108,120,108	0229 02F8 25304A3408 PERCNT	FCB \$25,48,74,52,8,44,82
0195 023E 6666	FCB 102,102	0230 02FF 0C	FCB 12
0196 0240 6C18181818 LL	FCB \$6C,24,24,24,24,24,24,24	0231 0300 2718181800 APOST	FCB \$27,24,24,24,0,0,0,0
0197 0248 6D0000667E LM	FCB \$6D,0,0,102,126,126,102	0232 0308 2A10543838 ASTERK	FCB \$2A,16,84,56,56,84
0198 024F 66	FCB 102	0233 030E 1000	FCB 16,0
0199 0250 6E00007C66 LN	FCB \$6E,0,0,124,102,102,102	0234 0310 3A00181800 COLON	FCB \$3A,0,24,24,0,24,24
0200 0257 66	FCB 102	0235 0317 00	FCB 0
0201 0258 6F00003C66 LO	FCB \$6F,0,0,60,102,102,102,60	0236 0318 3F3C66060C QUEST	FCB \$3F,60,102,6,12,24,0
0202 0260 7200007C66 LR	FCB \$72,0,0,124,102,96,96,96	0237 031F 18	FCB 24
0203 0268 7300003C66 LS	FCB \$73,0,0,60,96,60,6,60		* THESE LETTERS COME LAST * BECAUSE THEY HAVE DESCENDERS
0204 0270 7400183C18 LT	FCB \$74,0,24,60,24,24,24,12	0238 0320 673C666666 LG	FCB \$67,60,102,102,102,62
0205 0278 7500006666 LU	FCB \$75,0,0,102,102,102,102	0239 0326 063C	FCB 6,60
0206 027F 3E	FCB 62	0240 0328 6A06060606 LJ	FCB \$6A,6,6,6,6,6,102,60
0207 0280 7600006666 LV	FCB \$76,0,0,102,102,102,60	0241 0330 707C666666 LP	FCB \$70,124,102,102,102,124
0208 0287 18	FCB 24	0242 0336 6060	FCB 96,96
0209 0288 7700006666 LW	FCB \$77,0,0,102,102,126,126	0243 0338 713E666666 LQ	FCB \$71,62,102,102,102,62
0210 028F 66	FCB 102	0244 033E 0606	FCB 6,6
0211 0290 780000663C LX	FCB \$78,0,0,102,60,24,60,102	0245 0340 796666663C LY	FCB \$79,102,102,102,60,24
0212 0298 7A00007C0C LZ	FCB \$7A,0,0,124,12,24,48,124	0246 0346 3060	FCB 48,96
0213 02A0 303C666E7E N0	FCB \$30,60,102,110,126,118	0247 0348 000000	FCB 0,0,0
0214 02A6 663C	FCB 102,60		* THREE ZEROS ARE NEEDED HERE TO * MAKE THIS PROGRAM WORK WHILE * TACKED ONTO THE END OF THE * BASIC PROGRAM.
0215 02AB 3118381818 N1	FCB \$31,24,56,24,24,24,24,60	0248 0348	END START
0216 02B0 323C66060C N2	FCB \$32,60,102,6,12,24,48,126		



# MIND YOUR OWN BUSINESS WITH HOMEBASE™

The TRS-80\* Color-Computer  
**DATABASE ENHANCED**

Database Management, Word Processing and Spread Sheet Calculations in One Integrated Package

## Business Applications

- Real Estate
- Ledgers
- Mailing Lists
- Single Letters
- Memos
- Phone Lists
- Form Letters
- Charts
- Business Reports
- Inventories
- Income Tax Preparation
- Property Maintenance
- Property Rentals
- Receivables
- Payables
- Order Entry
- Business Contacts
- Appointments
- Client Profiles
- Document/Article Indexing
- Lab Reports
- Personnel Records
- Student Grades
- Budgets

## Homebase is Easy to Use

- No programming required. All options are displayed in menus. HOMEBASE automatically requests all required data and edits every entry.
- All commands are single key stroke.
- Full screen editing for text entry.
- Complete cursor control for entering names, titles, notes, comments and all other data.
- Over 100 pages of well organized and easy to use documentation with complete descriptions of every command, and examples.
- Requires 32K of memory, DISK BASIC and only one disk drive. No equipment modifications required.
- Fast response to all commands including search and sort.

### Enhancement:

- **A tutorial/demonstration file with step-by-step instructions.**

## Custom Report Writer For Data Management Files

- Merge data management files with text files
- Print one document per data record.
- Print one document for multiple data records by using a data field as a key for matching records.
- Use all printer control options.
- Print multiple copies.
- Print selected data records.
- Store multiple formats on a single TEXT file.
- Alter formats while using the REPORT WRITER or TEXT PROCESSING program

## Data Management

- Define 50 data fields, including a comment field, in a single record. Dates, time of day, phone numbers and dollar amounts are automatically formatted. You may also define 24 scratch-pad data fields not contained within your data records.
- Reorganize records by moving data fields within records or by moving records within a file. You may sort records in ascending or descending order using record names you assign or data values.
- Manage files by searching, deleting, clearing, duplicating, and displaying any data or record. Add, subtract, multiply, divide, or summarize any data field. Use any command on a single record or selected group of records. You may also selectively process any single data field or group of data fields.
- Print files using automatic

formatting with options to print report titles, a report date, page numbers, record names, and data field names. Print all or selected data fields or records.

### Enhancements:

- **Variable length alpha/text data fields.**
- **Use 1 or 2 disk drives.**
- **Range search for alpha/text data fields and record names.**
- **Calculator mode for entering new data field values while performing calculations and automatically displaying the results of calculations.**
- **Extended sort which permits sorting on any position within a comment alpha/text data field.**
- **Separate printer drivers for NEC and OKIDATA printers.**

## Text/Word Processing

- Define 250 screens of text you can search, sort, display, or print. Reference or select records using

record names you assign or by searching for any word or phrase within text records.

- Edit text by duplicating, moving, clearing, searching and replacing, deleting, or reordering entire records of text or portions of text records. Print the text record appearing on the screen to review before final print.
- Format labels, memos, letters, and other documents for printing with embedded printer controls for paging, skipping lines, and changing character fonts. Program controls provide for setting; right and left margins, lines per page, page width, horizontal tabs, and line spacing. Reuse control settings or change when desired. Print multiple copies. Merge text records to produce a form letter for an address file.

### Enhancements:

- **Use 1 or 2 disk drives.**
- **A separate printer driver for NEC and OKIDATA printers.**
- **Page numbering.**
- **Print page headings.**
- **Page backwards or forwards.**

## Utilities for Data Management and Word Processing

- Generating new files from old files.
- Merging files.
- Duplicating files.
- Moving data between files.
- Summarizing files.
- Moving files from diskette to diskette using a single drive.
- Saving files to cassette and reloading from cassette.
- File synchronizing.
- Print disk directory

### Enhancements:

- **Rename files.**
- **Extended summarize and update.**

**ORDER TOLL FREE 800-334-0854**

Credit card holders call toll free: 800-334-0854, extension 887 in North Carolina call: 800-672-0101, extension 887 or send a check or money order for \$75 + \$5 for handling charges to:  
**HOMEBASE™ COMPUTER SYSTEMS**  
P.O. Box 3448, Ourham, N.C. 27702  
90 day warranty

N.C. residents add 4% for sales tax. Allow 1 to 3 weeks delivery.

HOMEBASE™ is a trademark of HOMEBASE™ COMPUTER SYSTEMS, a subsidiary of Small Business Systems, Durham, N.C. (919) 544-5408.

\*TRS-80 is a trademark of Tandy Radio Shack, Inc.



# Speak Up! Speaks For Itself

With today's rapid gains in technology and the resulting drop in the cost of electronic components, digitally synthesized voice is becoming more and more common in our everyday lives. We have automobiles with little voices that tell us when we have left our headlights on, vending machines that talk to us and even computers that deliver sales pitches over the phone. Now *Speak Up!*, a 100% software speech synthesis program, lets the CoCo communicate with the real world in a voice of its own.

*Speak Up!* is a machine language program that is capable of reproducing 37 of the most common English language phonemes on the CoCo's television speaker. (The phoneme is the fundamental unit of speech). The cassette on which it is delivered contains both a copy for 16K machines and a copy for 32K machines. Both versions take up less than 7K bytes of memory and run in one of two modes, (1) an interactive mode where words and sentences to be spoken are typed on the keyboard and (2) a BASIC program mode where *Speak Up!*'s input is passed in by a running program.

After a quick pass through *Speak Up!*'s complete, clear and informative documentation, I was ready to fire up my CoCo and hear its first ever spoken words. Running *Speak Up!* in the interactive mode, it was with great anticipation that I typed at the prompt, those immortal, timeless words, "HELLO WORLD!" Sure enough, my CoCo announced itself with its newfound voice and I was pleasantly surprised by the quality of the voice emanating from the speaker.

*Speak Up!* produces meaningful, understandable sounds by scanning the words and sentences input to it for certain letter pairs and single letters that it can pronounce. For example, the letter sequence CH produces a sound such as found in the word "chip." Sounds are strung together to produce coherent output. Punctuation in the input string produces varying periods of silence; a space (like between words of a sentence) causes a single, silent pause to be output, a comma causes two pauses and a period, three. All other characters (i.e. numbers and other punctuation) are ignored.

The author's desire to keep *Speak Up!* a reasonable size, coupled with the inherent complexities and inconsistencies of the English language, make it relatively easy to fool *Speak Up!*'s letter to-phoneme mapping scheme. For example, the word "champagne" comes out sounding like "CHAMP-AG-NN." By the use of a little creative spelling (i.e. "SHAMPAYN" in the example above), proper pronunciation can be obtained. With the letter-to-sound chart attached to *Speak Up!*'s documentation and some practice, I was quickly able to figure out alternate spellings for almost any word, like COMPYEWTER for "computer" and FIEV for "five."

Running *Speak Up!* in the BASIC program mode also proved to work out well. There are clear examples on how to interface to both Color BASIC (via "PRINT@0 (DATA)" statements) and Extended Color BASIC (via DEFUSR and USR functions) contained in the documentation. It was an extremely simple exercise to write a program to read text files out loud (although enhancement to look for and re-spell "problem" words would have added some polish to my program). The number of applications for *Speak Up!* seems to be limitless.

Overall, I am impressed with the quality of *Speak Up!* and its documentation and feel that it is a tool that would make a nice addition to any CoCo software library.

(Classical Computing, Inc., P.O. Box 12247, Lexington, KY 40582, \$29.95)

—Gary E. Epple

## Color Computer Enhancements from Micro Technical Products

### \*LCA-47—Lower Case Adapter

- Smart improvement!
- Compatible with ALL Color Computer Software
- Bright characters on a dark background
- Lower Case with true descenders
- Comprehensive User's Manual
- Easy 5-min. installation . . . no cutting, no soldering
- Uses NO system memory
- 1 year warranty!

Assembled & Tested. . . . . \$75.00

### \*PP-16—EPROM Programmer

- 5 volt EPROMs: 2516, 2716 & 2758
- Read Program. Verify data. Verify erased
- Auto verify after programming
- Software available for: 6502, 6800, 6809, 8080, 8085, & Z80 (specify one)
- Note: User must provide interface to computer

Bare PC Board & Documentation. . . . . \$25.00  
Complete Kit. . . . . \$45.00

### \*PAK ATTACK—

- From Computerware
- Great fun for all "kids" without the quarters
- Fast action, brilliant colors

Tape . . . . . \$24.95

### \*Super 'Color' Writer II—

- From Nelson
- Taps ALL word processors for the Color Computer!
- More features
- Supports ANY line printer
- Comprehensive documentation

ROM PAK..\$74.95 Disk..\$99.95

### \*ROML—ROM PAK Loader Program

- Innovative!
- Save your ROM PAKS on disk and run WITHOUT removing disk controller (requires 64k RAM)
- Load and run ANY machine language program.
- FREE program included to copy machine language programs from tape to disk

Tape . . . \$25.00 Disk . . . \$29.00



### \*ROMKIL—BASIC ROM Disabler

- Disables Disk BASIC ROM or Extended BASIC ROM
- Frees up extra RAM
- System stays in selected level of BASIC even if Reset
- Cycling power restores all ROMs

Tape . . . \$15.00 Disk . . . \$19.00

### \*PLUS32—64k RAM Enabler

- Runs BASIC from RAM where you can modify it
- Allows you to load machine language programs above BASIC
- Requires good 64k RAM system

Tape . . . \$15.00 Disk . . . \$19.00

### \*BANNER—Moving Marquee Program

- Display any message in GIANT m\_o\_v\_i\_n\_g letters
- You choose colors & speed

Tape . . . \$19.00 Disk . . . \$23.00



### \*SPECIAL SAVINGS—\$25.00 Off when you purchase Super 'Color' Writer II and an LCA-47 together!

## — ORDER NOW —

16K	32K	64K	128K	256K	512K
LCA-47	\$75.00	\$75.00	\$75.00	\$75.00	\$75.00
PP-16	\$45.00	\$45.00	\$45.00	\$45.00	\$45.00
PAK ATTACK	\$24.95	\$24.95	\$24.95	\$24.95	\$24.95
Super 'Color' Writer II	\$99.95	\$99.95	\$99.95	\$99.95	\$99.95
ROML	\$25.00	\$25.00	\$25.00	\$25.00	\$25.00
ROMKIL	\$15.00	\$15.00	\$15.00	\$15.00	\$15.00
PLUS32	\$15.00	\$15.00	\$15.00	\$15.00	\$15.00
BANNER	\$19.00	\$19.00	\$19.00	\$19.00	\$19.00
SPECIAL SAVINGS	\$25.00	\$25.00	\$25.00	\$25.00	\$25.00

Micro Technical Products, Inc.  
123 N. Sirmine, Suite 106-A2  
Mesa, AZ 85201 (602) 834-0283

Add 5% for shipping, minimum \$2.00.  
Overseas 10%, min. \$4.00. Arizona, add 5% tax. Visa & MasterCard welcome.

## Submitting Material To the Rainbow

Contributions to *the RAINBOW* are welcome from everyone. We like to run a variety of programs which will be useful/helpful/fun for other CoCo owners.

Program submissions must be on tape or disk and it is best to make several saves, at least one of them in ASCII format. We're sorry, but we do not have time to key in programs. All programs should be supported by some editorial commentary, explaining how the program works. We're much more interested in how your submission works and runs than how you developed it. Programs should be learning experiences.

We do pay for submissions, based on a number of criteria. Those wishing remuneration should *so state* when making submissions.

For the benefit of those who wish more detailed information on making submissions, please send a SASE to: Submissions Editor, *the RAINBOW*, P.O. Box 209, Prospect, KY 40059. We will send you some more comprehensive guidelines.

Please do not submit programs or articles currently submitted to another publication.

# Four smart ways to make your Atari 400/800, TRS-80 COLOR, VIC-20 and Commodore 64 much more intelligent.

## 1

**The Color Accountant pays for itself.** This *complete* personal financial package is designed to make your money easier to manage. Included are:

1. *Checkbook Maintenance*
2. *Chart of Accounts*
3. *Check Search*
4. *Income/Expense Statement*
5. *Net Worth Statement*
6. *Color Graph Design Package*
7. *Home Budget Analysis*
8. *Color Payments Calendar*
9. *Mailing List*
10. *Decision Maker*

This unique menu-driven package requires less than one hour data input per month. The Color Accountant has over 60 pages of documentation including examples and step-by-step instructions. TRS-80 COLOR requires Ext. Basic and 16K for cassette, 32K for diskette; Atari 400/800 requires 24K for cassette, 32K for diskette; VIC-20 requires 16K Expander. Now available for Commodore 64.

**\$74.95 cassette;  
\$79.95 diskette**

## 2

**The Tax Handler makes April 15th just another day.**

This is the perfect complement to our Color Accountant. The Tax Handler will help prepare your tax returns and probably save you money. Included are:

1. *Form 1040 (Long Form)*—filing status, exemptions, income, income adjustments, computation of tax, tax credits and payments or balance/refund due.
2. *Schedule A (Itemized Deductions)*—medical and dental deductions, taxes, interest expenses, contributions, casualty/theft losses, miscellaneous deductions and summary.
3. *Schedule G (Income Averaging)*—base period income and adjustments, computation of averageable income and computation of tax.

Additional schedules or alterations to the tax codes will be available separately in our monthly magnetic magazines. Atari 400/800 requires 24K for cassette, 32K for diskette. VIC-20 requires 16K Expander. Now available for Commodore 64.

**\$34.95 cassette;  
\$39.95 diskette**

## 3

**You'll love your computer with The Magnetic Magazine.**

Our magnetic magazines will entertain, inform, educate, challenge and delight you. Each issue contains 4 to 7 ready-to-use quality programs, all fully listable. Every issue includes a newsletter containing instructions, tips on programming techniques and a line-by-line examination of the feature program. And starting with issue number 8, the first in a series of tutorials on machine language programming, Database I with a new application every following issue and a new utility in our Utility-of-The-Month section. And word processing is coming soon!

A full year's subscription consists of 10 issues—over 50 programs a year at a mere fraction of their cost. Available for TRS-80 COLOR Ext. Basic, Atari 400/800; all require 16K. Back issues available.

**One year subscription:  
\$50.00 cassette;  
\$75.00 diskette  
Half year subscription:  
\$30.00 cassette;  
\$45.00 diskette  
Sample issue:  
\$10.00 cassette;  
\$15.00 diskette  
VIK VIDEO issue 1 available  
for VIC-20; \$12.95 cassette**

## 4

**The Learning Center teaches and enlightens children.**

Our exceptional educational programs are classroom designed and tested. These unique packages have been invented to introduce 3 to 9 year olds to the ease of computer learning. Through the use of basic concepts such as colors, shapes, numbers and letters, children understand counting, math and language skills. Each program is designed to develop a specific skill, rewarding each correct answer with music and a happy face. Most are compatible with our new Edumate Light Pen \$34.95.

Available for Atari 400/800, VIC-20 and Commodore 64; all require 8K for cassette, 16K for diskette. Also available for Timex/Sinclair 1000 and TI-99.

**Please ask about programs available and their prices for Pre-School, Kindergarten and Grades 1 & 2. Prices range from \$8.95 for a single cassette to \$79.95 for a complete set on diskette.**

Order now! See your local dealer or order direct. New catalog \$2.00. Visa and MasterCard accepted—please add \$2.00 for postage and handling.  
Call toll free!

# 1-800-334-SOFT

DEALER INQUIRIES INVITED

# programmer's institute

a division of **FUTURE HOUSE** — dept. r  
p.o. box 3470, chapel hill, north carolina 27514, 919-967-0861

## File Cabinet: Excellent Utility For The Adventurous

In search of a versatile filing program with the flexibility of a Data Base system, I eagerly pored over *File Cabinet* from Moreton Bay Software.

As I read the narrative, I discovered that the author has included two adaptations of the basic program, a Recipe File and an Address File, complete with sample data files.

These additional programs were included to demonstrate the versatility of the BASIC program. The documentation for this program consists of nine pages of running narrative which primarily describes how to find *Tomatoes in Salad* (Salad is the Data File for Recipe).

I can't wait for the salad, I have to get to the meat of the program, the *File Cabinet*. After all, it can't be that difficult to set up a file.

*CLOAD*, okay. *RUN* okay. Read the title page and copyright, okay. Next screen, *CREATE* or *LOAD*. Since I don't have a tape file, I select *CREATE* which then prompts for the number of Entries (Fields) per Record, 2-20. After *ENTERing*, the screen proudly displays the number of Records available in memory using an average of 10 characters per field. Is this enough? A No response automatically reduces the average field size to increase the amount of available records. This is great.

The next prompt is for a file name. Then, enter field names by prompt. An incorrect entry, what to do? No instructions, the Adventure begins. (I begin to think of *File Cabinet* as sort of a "Utility Adventure," but the command *TAKE LAMP* sheds no light.) At the end of the Field Name entry, there is a prompt, "CORRECT Y/N." But, no response will have you redo *all* field names.

After naming the fields, the *ADD* or *MENU* prompt appears. At this point, the author wisely suggests that you enter a few trial records to develop familiarity with the commands and functions. Good Advice.

We now have a few records with a few fields. The Adventure continues. Let's examine the *MAINTENANCE MENU*, the most complete I've seen for the CC.

*ADD*, simple enough. *SORT*, by selected field, great! No, wait, danger lurks! The ASCII sort routine thinks a 2 is larger than 15 unless you avoid this peril by using leading zeros.

*CHANGE* and *DELETE*. Unfortunately, these commands will only allow access to one record in the file before returning to the *MENU*.

*FIND* will locate multiple occurrences in a specified field of any character or string. This is very useful to aid in locating records for *CHANGE* and *DELETE*, but you need

a scratch pad and pencil.

*LIST*, sort of an Inventory command to let you see your file "treasures" on the screen—if the record data will fit on one screen. You can page through records in sort order or return to the menu.

*REMAINING MEM.* is a nice feature for small machines or large files. Select this option to display bytes and record space available.

*MAIN MENU*, there are five corridors out of here. *MAINTENANCE MENU* takes you back to where you were. *SAVE* takes you to cassette. *QUIT* takes you to Basic (*GOTO 10* will get you back with your data). *TOTAL* will total a field from all or selected records. The total is only displayed on screen with a record count and numeric average.

*REPORT*, the most versatile, yet least described function. When you get here, it's like getting through *Raaka-Tu* with only half enough points. The function call is self-prompting, but somewhat confusing. The first prompt, *Print to Screen or Printer*, is selected. The output for either option is similar except on Screen, you must page through all selected records with end of file being your only access back to the menu.

The next prompt is for an arithmetic field. If Y, you are prompted for *number of 1st entry field*. Once done, you can select the appropriate math function from +, -, \* and /. The program then adds a new field to every record and asks for the 2nd entry field. This is the numeric value you wish to use. This value is placed in the added field. The next prompt is to name the (results) field.

You are then allowed to select which fields will be printed and if you want the field heading printed. Each field is printed at the left margin which makes it difficult to format any type of table.

The final series of prompts in this routine ask which fields to select if you did not select an earlier *ALL* fields prompt. The next prompt, *Input search start parameter*, was confusing until I remembered the ASCII trap. You can enter any value that will find a match in your selected field. The *Input end parameter* will allow you to select a range of values within a field. At last, *press any key to print*.

I believe I managed to escape with all the treasures the *File Cabinet* Utility Adventure contains. This filing program is the best I've seen for the CC and is very close to being outstanding in its function, but the documentation needs to be rewritten so that all the functions in this program can be fully exploited other than by the trial-and-error, or "Adventure," method. Now, if we can only get an ML sort routine included . . .

(Moreton Bay Software, 316 Castillo Street, Santa Barbara, CA 93101, \$29.95 on tape)

—Ed Sehlhorst

### AUDIO AND VIDEO INTERFACE

Provides SWITCHED color or monochrome 75ohm, 1 volt p-p video from CoCo.

If you wish to use a high resolution monitor this interface is a must.

Separate enhancements are provided for color and monochrome outputs.

This is not a simple emitter-follower add-on.

- \*UNIT DOES NOT REQUIRE SOLDERING
- \*INTERFACE IS ASSEMBLED AND TESTED
- \*400mw AUDIO @ 8 ohms
- \*TWO YEAR WARRANTY

Price \$49.95 (Includes Shipping)

**FREELAND ENG.**

7503 N. Kerby, Portland, OR 97217





SINCE 1981

A BRAND NEW GAME AND ONLY FROM ZETA

### WORMHOLE™

by John Bobst

*An original all-machine-language game  
for the TRS80 Color Computer:*

- \*1 to 4 players (taking turns,  
"in-progress" savable)
- \*6 distinct sound effects  
(7 if counting "foosh")
- \*1 joystick and 16K either  
BASIC required (average?)
- \*8 colors on a black screen  
(Semigraphics 12)
- \*1 "pause" key, 1 exit key, and  
1 reset key (handy)
- \*255,999,999 points possible  
(not @#%&! likely)
- \*9 speeds/skill-levels  
(changeable during play)
- \*4 copies on 1 cassette  
(disk savable/loadable)
- \*1 source only  
(at a "factory direct price")

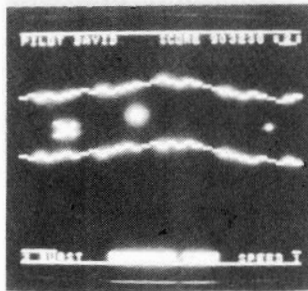

A great **description** for \$29.95, but **WORMHOLE** is a great **game** for only

\$17.95 + 2.50 S&H  
(\$20.45) to:

**ZETA SOFTWARE**  
P.O. Box 3522  
Greenville, S.C. 29608

FREE catalog with order or write or call. No COD's, PO's or  
charge cards, please. TRS80™TANDY Corp. **WORMHOLE**™  
ZETA Computer — Phone: (803) 246-1741 — 1-9 p.m. EST.

GET A CATALOG FOR INFO ON YET ANOTHER  
NEW PROGRAM: "EL CHEAPO™ AND CONVERTER"

**ZETA SOFTWARE**  
**P.O. BOX 3522**  
**GREENVILLE SC 29608-3522**

## Bar Zapper: Well-Documented Tool For Color Computer

Screen Print using the *Bar Zapper* and Custom Software Screen Print Program

Radio Shack w/LP-100 Printer

If a picture is worth a thousand words, what is a high resolution bar graph worth?

Plenty! To anyone who works with numbers, forecasts, computations and statistics.

There is nothing like a graph to convert a series of comparative figures into an instantly understandable visual presentation.

*Bar Zapper* is the second graph preparation program from Southern Software Systems, following their original *Graph Zapper* program. While *Graph Zapper* creates line graphs, *Bar Zapper* makes bar graphs (logical enough).

For those unfamiliar with bar graphs, they are the type of graphs which represent and compare statistics in the form of columns or towers rising or falling (for negative values) from a base line.

Bar graphs allow instant comparisons of values. A taller column represents a value greater than a shorter column. Easy...

With *Bar Zapper*, the Color Computer produces high quality bar graphs using data entered by answering a series of inquiries generated by the program.

*Bar Zapper* allows you to:

- Add bars to the graph
- Change bars on a graph
- Insert bars in an existing graph
- Delete bars from an existing graph
- List the data which the CoCo will use to generate the graph and allow changes
- Save and load the data and completed graphs to or from disk or tape.

The user defines the minimum and maximum values for the bars, the number of bars and sub-bars (more about that later) and if there will be lines crossing the graph or not. Using these variables, a custom graph is created. Each axis of the graph is labeled and each bar can be titled. A unique staircase label option allows longer bar titles by slanting the titles downward so they won't run into each other. In addition, the entire graph can be labeled with a reversed title banner across the top of the screen.

While the above may seem complex, the program is extremely easy to use and is supported by a concise 23-page manual which answers most possible questions, including what to do if the program aborts.

The main event is when you zap (print) the graph on the

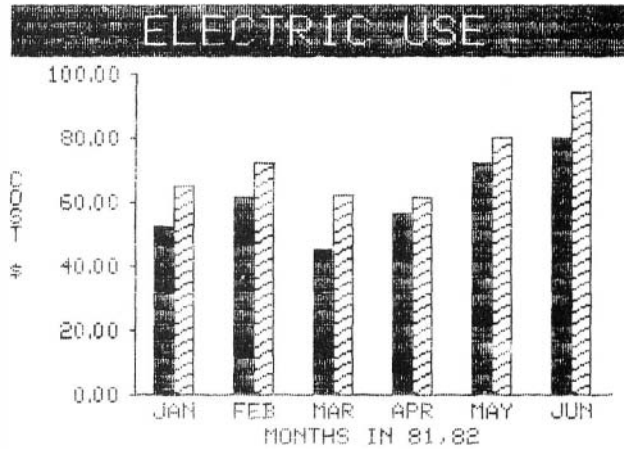

screen. The title appears, followed by the bars, followed by the titles. Beautiful!

The graphs are displayed using *PMODE4* for the highest resolution. So you are limited to a choice of two color combinations, either green and black, or buff and black. Instead of using different colors to differentiate between the bars you have a choice of five different types of bars. While different colors would be more desirable, the various designs are very unique with little chance of confusing the bars.

After the graph is zapped, it can be changed or stored for future reference.

In *Bar Zapper* each bar represents a whole value. Comparisons are made between two or more values by using the sub-bar option where a group of bars are presented connected to each other. In the example, the graph shows six bars, each consisting of a bar and one sub-bar. The maximum number of bars for *Bar Zapper* is 24, with up to five sub-bars for the 32K version and three sub-bars for the 16K. The 32K zapper contains many nice extras which are omitted from the 16K zapper because of lack of memory.

After your graph is zapped on the screen, now what? *Graph Zapper* allows the printing of your graph using a screen print program and a printer with graphics capabilities. A set of modifications are included in the *Bar Zapper* instructions to automatically make hard copies using the screen print program from Custom Software Engineering. If you have a 32K CoCo, this modification allows you to make screen prints with the push of a button.

When *Bar Zapper* was printed using the Radio Shack Screen Print Program (now discontinued), the print included a black line across the bottom of the graph which wasn't on the graph. Using Custom Software's program, there was no such problem. The two programs were designed to merge together and I would highly recommend doing so to get full use from *Bar Zapper*.

In summary, *Bar Zapper* is a well-prepared and documented tool for the Color Computer. (Custom Software Engineering has the recommended *Screen Print Program*. They're at 807 Minuteman Causeway, Cocoa Beach, FL 32931.)

(Southern Software Systems, 485 Tropical Trail, Suite 109, Merritt Island, FL 32952, 16K tape version, \$15.95; 32K version for tape or disk, \$19.95.)

—Bruce Rothermel

and **COLORPEDE**

**ROBOTTACK**

# COLORPEDE

This truly outstanding engineer designed, 100% machine language game with multi-colored high resolution characters and fast action will challenge the most avid arcade buff. Can be played by 1 or 2 players controlled with joy sticks or key board. Joy stick control is fast, smooth and accurate. As COLORPEDE slithers through the toad stools, you attempt to destroy the COLORPEDE, knock out the menacing Bouncing Bug and eliminate toad stools while accumulating higher and higher scores. Demonstration mode with top 5 scores. Pause feature. For 16K Color Computer and TDP-100.

Cassette - \$29.95

Disk - \$34.95

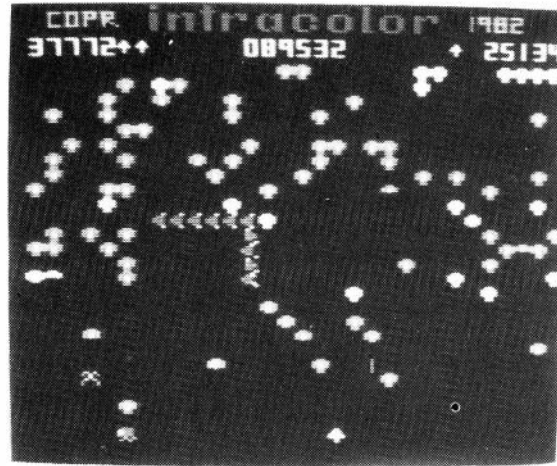

Actual Photo

### WHAT THEY ARE SAYING ABOUT COLORPEDE

"... forefront of the pack..." **the Rainbow**, Dec. '82

"... the best graphics and playability of any color computer game..." McKeesport, PA

"It is great!" Dayton, OH

"... an outstanding offering." N. Vernon, IN

"... the best graphics I have seen to date." Erie, PA



SETTING THE STANDARDS

**INTRODUCING**

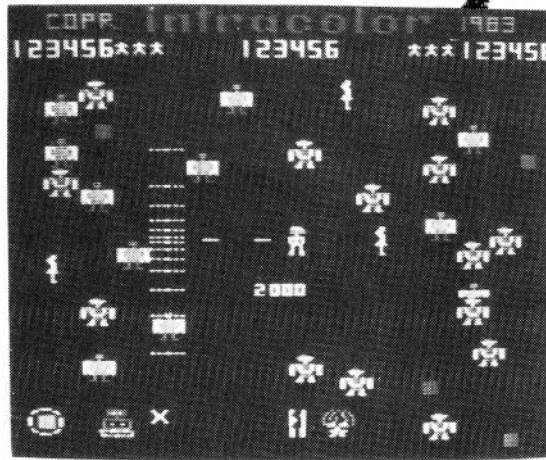

Actual Photo

# ROBOTTACK

Ultra fast arcade action with colorful high resolution graphics. You are the super human who must fight off the attacking robots and save the remaining humans from destruction. You have super powers, can shoot in any direction and move anywhere on the screen to accomplish your vital mission.

Engineer designed, 100% machine language. Can be played by 1 or 2 players with joy stick control. Top 5 scores displayed. Pause feature. For 16K Color Computer and TDP-100 with joy sticks.

Cassette - \$24.95

Disk - \$27.95

**TO ORDER:** VISA, MASTERCARD, Money Order. Please allow 2 weeks for checks. Add \$1.50 for shipping, \$3.00 outside U.S. 4% tax in Mich.

DEALER INQUIRIES INVITED.



FOR THE COLOR COMPUTER & TDP-100



## Super "Color" Disk Zap Adds The Missing Capabilities

The Radio Shack Disk Operating System has many capabilities. With it, you can load and save files and data. You can list the files on disk, copy and rename files, and backup your disks. At first glance, it would seem that it can satisfy all of your needs. But what if the system decides to clobber the directory? Or, what if you decide that you want to inspect or modify a portion of the disk, or a file on the disk? All of a sudden, the system seems to have fewer capabilities.

*Super Color Disk Zap* is a machine language disk utility program that has many useful features. With it, you can inspect or modify your disks in any manner desired. You can also display the directory, and print any portion of the disk. It also supports the transmitting of files to another computer using the RS-232 port. In addition, it has a verify function that will find the bad spots on a disk, a copy function to copy sectors to any drive and sector, a locate function to find any ASCII or hexadecimal string, and a kill function to delete any file. It supports up to four drives and even supports drives with more than 35 tracks.

Using *Super Color Disk Zap* is easy. After you load the program, it auto-executes and displays a title screen while the rest of the program is being loaded. After the program is loaded, the master menu is displayed with a choice of 12 commands. If I were to completely describe every command, and the variations thereof, you would have to spend the next half-hour or so reading this review. The purpose of a review, I feel, is to provide an overview of the product's

functions and operating features, and to help you decide if you should purchase it or not. With that in mind, let's see what *Super Color Disk Zap* can do.

The DIRECTORY command, as you might guess, displays the disk directory on your screen. The display is formatted into two columns and includes the number of free granules. If you have a lot of files on your disk, the display will pause when the screen is filled. Pressing any key will display the next page or return you to the menu if it is the last page. When the program reads the directory, it also checks the file allocation table for errors. If it finds one, the file name is flagged to warn you of the error.

The VERIFY command is probably the best of all. When it is invoked, it searches the entire disk for errors. If one is found, it will pause and display the track and the sector in error so that you can attempt to fix it. While reviewing this program, I recalled having a disk that I could not backup. All I knew was that the backup command gave me an I/O error, and I could not load one of my files. This seemed like a good test of the VERIFY command, so naturally I tried it. When I did, I was not only informed as to where the error was, but I was also told what type of error it was. A quick glance at the documentation explained exactly how this type of error might be fixed. Following the instructions I proceeded to "fix" the disk. After that I did another VERIFY of the disk and, sure enough, there were no errors. Although I had no reason to doubt what the program was telling me about my disk, I exited the program and proceeded to load the file that was previously bad. Not only was I able to load the file and backup the disk, but the file was completely intact and did not require any additional changes to be made. If you have ever lost an important file or disk due to some unknown error, the feature alone is worth the entire

# COMPUKIDS MAGAZINE

### The Computer Magazine for Beginners

Educational articles that are easy to understand  
Game programs  
Computer book reviews  
Program problems

### CompuKids Club

1 year magazine subscription  
Contests with GREAT prizes  
Free computer advice  
Program exchange  
Educational programs  
... and lots more ...

- One year subscription *plus* one year membership in CompuKids Club — \$24.00 (Canada — \$31.00)
- One year subscription only — \$16.00 (Canada — \$20.00)
- Six month trial subscription — \$9.00 (Canada — \$11.00)
- Payment enclosed (check or money order)
- Please bill me later (a \$1.00 billing fee will be added)

(Special School and Group Rates Available)

Name \_\_\_\_\_ Age \_\_\_\_\_ Signature if billing \_\_\_\_\_

Address \_\_\_\_\_ City \_\_\_\_\_ State \_\_\_\_\_

Zip Code \_\_\_\_\_ Phone \_\_\_\_\_

Mail Check or Money Order to:

CompuKids Magazine RB  
P.O. Box 874  
Sedalia, MO 65301

Or Phone TOLL FREE:  
1-800-822-KIDS

price of the program.

The FILE ZAP command allows you to display and/or modify any file on the disk. When invoked, a sub-menu is displayed. The commands available from this menu include finding the first or last granule, as well as reading or writing a sector. Browsing through the file is done with the arrow keys. You can go forward or backward by sector or granule, with the print function being available at all times. When the MODIFY sub-command is invoked, the screen display is broken into two halves. The top of the screen displays the data in ASCII and the bottom of the screen displays it in hexadecimal. When modifying data, you can do it in either ASCII or hexadecimal. The very bottom of the screen always displays the track and sector numbers that you are working with. This command is very handy when working with files, since the program will automatically find them for you.

The DISK ZAP command is very similar to the FILE ZAP command. It, too, presents you with a sub-menu. The difference here is that you are working with the disk as a whole, and not on a particular file. This menu also contains the LOCATE function which allows you to find all the occurrences of an ASCII or hexadecimal string on the disk. You might be wondering why the DISK ZAP command is included in the program. After all, the sub-commands available are essentially the same as those of the FILE ZAP command. After pondering this for a while, I realized that this would be the only way to get at the directory or the file allocation table, since they cannot be accessed by file name.

The READ and WRITE SECTOR commands are pretty self-explanatory. You can read any sector on any drive, and then write it out to any sector on any drive. The interesting thing about these commands is that you can read and write more than one sector at a time. With 32K, you can read or

write up to 92 sectors at a time.

Although you could have a lot of fun zapping (or should I say zapping) through your disks, *Super Color Disk Zaps*' strength lies in fixing disk problems. The VERIFY command will find the error, but what if the error is in the directory or the file allocation table or smack in the middle of your basic program. How would you go about fixing it? Here is where the documentation (52 pages worth) comes into play. Needless to say, it fully describes all of the commands and how to use them. The section of the documentation which discusses "Zapping Techniques" goes a long way to help you in fixing your disk problems. This section alone is 19 pages and covers such things as the disk structure, dealing with the various types of errors, reallocating a granule, fixing a tokenized basic program, rebuilding files and tracks, and recovering KILLED files. I found this section of the documentation to be very informative, and even learned a few things about the disk system. The program comes on a protected disk which you cannot copy or backup. Normally this would be a problem, but since you also cannot write on the disk, the chances of wiping it out are slim at best.

By now you might be asking yourself "What can't *Super Color Disk Zap* do?" Well, so far I have been unable to get it to shovel my driveway after the blizzard we just had here, and it also would not print the disk directory on my printer. *Super Color Disk Zap* is an excellent, well written, and well documented disk utility. If you are at all serious about your disk system, this program is a must. Mr. Tim Nelson, the author, is to be congratulated on a job well done.

(Nelson Software Systems, 9072 Lyndale Ave., So., Minneapolis, MN 55420, \$49.95 disk)

—Gerry Schechter



# CANADIANS



P.O. BOX 513  
LASALLE, QUE.  
H8P 3J4

# F & T SOFTWARE

INQUIRIES & ORDERS  
CALL (514) 365-5392  
BETWEEN 1 & 7 P.M.  
(E.S.T.)

LOWEST PRICES IN CANADA — PROMPT DELIVERY — C.O.D. ACCEPTED — NOUS PARLONS FRANÇAIS

**64K RAM**  
IN ROMPACK FORM  
NO INSTALLATION  
NECESSARY  
**\$55.00**

#### GAMES BY COMPUTERWARE

RAIL RUNNER	26.50
COLOR INVADERS	23.50
STARSHIP CHAMELEON	29.50
MAZERACE	23.50
DOODLE BUG	29.50
EL DIABLERO	23.50
STARSHIP CHAMELEON	29.50
COLOR PAC ATTACK	29.50

#### GAMES BY MARK DATA

CAVE HUNTER	29.50
BERSERK (EX HAYWIRE)	29.50
SPACE RAIDERS	29.50
ASTRO BLAST	29.50
BLACK SANCTUM	23.50
CALIXTO ISLAND	23.50

#### GAMES BY SPECTRAL

CC THELLO	18.00
GAME PAC III	18.00
PIRATES AHOY	12.00
DESERT GOLF	12.00
DEFENSE	26.00
PLANET INVASION	26.00
YAHTCC	12.00
GALAX ATTAX	26.00
KEYS OF THE WIZARD	23.95
SPACE WARS	26.00
SPACE INVADERS	26.00
GHOST GOBBLER	26.00
ROBOT BATTLE	26.00
TRILOGY	71.00
COSMIC SUPER BOWL	18.00
CROID	18.00
GRAPHIC ANIMATOR	12.00
GAME OF LIFE	18.00
COLOROUT	15.00
SPACE TRADERS	18.00
LASER COMMAND	14.00
SUB HUNT	18.00
ALCATRAZ II	15.00
LOTHAR'S LABYRINTH	12.00
BATTLEFLEET	18.00
GAME PAC I	18.00
GAME PAC II	12.00

#### UTILITIES

COLOR DIAGNOSTICS	21.50
COLOR MONITOR	29.50
COLOR ASSEMBLER	36.00
COLOR EDITOR	36.00
DISSASSEMBLER	18.00
BUGOUT (MONITOR)	24.00
MAGIC BOX	30.00
SOUNDSOURCE W/CABLE	30.00
SOUNDSOURCE	24.50
COMPUVOICE	54.00

#### BOOKS

COLOR COMPUTER GRAPHICS	16.70
COLOR COMPUTER SONGBOOK	13.50
55 MORE COLOR COMPUTER PROGRAMS FOR THE HOME, SCHOOL OR OFFICE	16.70
55 COLOR COMPUTER PROGRAMS FOR THE HOME	16.70
101 COLOR COMPUTER PROGRAMMING TIPS AND TRICKS	13.50
6809 ASSEMBLY LANG. PROGRAMMING	24.00
THE FACTS	22.00
6809 REFERENCE CARD	2.50

**PRICE IN  
CANADIAN \$\$**

**ORDERS:** Quebec Residents Add 9% P.S.T.  
Personal cheques and C.O.D.'s are Welcome — C.O.D.'s under \$100 pls add \$1.50 to cover postal charges.  
No Additional Shipping Charges

**CATALOGUES:** For any of the following mail \$1.00  
(Refundable on first order)  
Color — Apple — Atari — TRS 80 I & III

**FREE SHIPPING & HANDLING — FREE INSURANCE — NO HIDDEN CHARGES**

## Robots Maneuver Humans Into Programming

My sons, Peter and Andrew, are 13 and 11 respectively. At this stage in our family's involvement in computing, the main intrigue for them is, of course, the arcade-style games they can play. I'd love to have them learn something about programming—after all, one of the reasons this creature with all its paraphernalia occupies one side of the living room is that they need “basic computer literacy” in order to grow into the world they will eventually inherit.

What does this have to do with *Robot Battle*, a new piece of cartridge software from Radio Shack? Well, *Robot Battle* popped into my life at just the right time to serve a particular need. I was looking for a language or operating system for my 32K Extended 80-C that would be easy and intriguing for the kids, and teach them some principles of programming. Quite frankly, I ended-up ruling out Color Logo, an otherwise reasonable choice for a couple of reasons: first, being able to draw on the screen with Turtle Graphics is not a motivating factor, if you have several other graphic programs in the house that take less effort. We have *Art Gallery* and *Microprinter* (Radio Shack), *Semi-Draw* (Computerware), and the *XPAD*. Oh yes, and Chromasette Magazine with *DRAWER*. See what I mean? The second reason I didn't choose Logo as a learning language for the kids is that the drawing-on-the-screen motivation is also a little bit above their age level. (It's not above mine, but that's another story.) Game playing is what they're “into.”

Now we get to *Robot Battle* (Subtitled “Adventures in Programming”). The program presents two tank-like robots (one red with a blue gun, the other blue with a red gun) on a black field. At the bottom of the screen are a blue and red line indicating available energy for each robot. The user's objective is to *write a program* for his/her robot that will help it win against the other robot. Both robots need pro-

grams, so the game works best if it's played with two players. But, there are demonstration programs for both robots, either of which could be retained to do battle against. You could also use the same program for both robots—at least that way they would be evenly matched.

There is a full-screen editor for entering/editing your programs. It's a little hard to adjust to having the arrow keys move the *text* up and down rather than moving a cursor, but that's the only drawback to the editor. After creating a program, you return to the beginning menu, from which you have these options: NEW, EDIT, SAVE, LOAD, COMPILE and BATTLE. For each option, there is a corresponding command for either left or right—except BATTLE, which obviously involves both robots.

The “language” you need to master in order to write your robots' programs is remarkably Logo-like. In fact, *Robot Battle* might be suitable as a stepping-stone into deeper waters such as *Game-Writer* or *Logo*. The language of *Robot Battle* is also very easy to learn. Testimonial from my 11-year-old: “This is *easy* to program!”

There are directional movement commands (F,B,R,L,H) for *forward*, *back*, *right*, *left*, and *halt*; “T” for *turn* a certain number of 45-degree units and “D” for facing a particular *direction*; “M” and “L” for your two weapons, *missles* and *lasers*, with “X” for *execute* one of them; “=” for “*if true* and “#” for *if not true*; a random function, “?”, to have some portion of a program occur only every once in a while; and searching abilities with “S” for *anything at all in any direction* or “=M,” *if missile*; “=R,” *if robot*; “=W,” *if wall* for the particular direction the robot is facing. “#M,” “#R” and “#W” mean *if no missile*, *if no robot* and *if no wall*.

At the simplest level, programs can be entered one line at a time (no line numbers are used). Multiple commands on a line are separated with a colon. The program will automatically cycle back to the beginning when executing. There is, however, a more sophisticated approach available: the use of labeled subroutines. You can use any word you want as a label, as long as it doesn't exceed six characters. The definition of a procedure follows this syntax: LABEL, “greater-than” symbol, space, then a string of commands. Once you have created a few subroutines, they can be called with C (like *GOSUB* in BASIC) or jumped-to with G (similar to *GOTO*).

One really fantastic aspect of *Robot Battle* is that the language is fully *recursive* and *re-entrant*. “What's that?” you ask. It means that you can get into some pretty sophisticated programming structures by having a procedure *call itself!* The sample programs included here (for robots named *Fred* and *Irving*) don't make use of this, but recursivity helps in creating extremely *intelligent programs*.

### \*FRED

```
ROB> =R: XL: CMIS: CRAND: GROB
WAL> =W: T5: F4: CROB: GWAL
RAND> =?: T2: F8
LOOK> =S: T1: CROB: CWAL: GLOOK
MIS> =?: XM: CDLAY
DLAY> B2: F3
START> CROB: CWAL: F8: =?: T1
CLOOK
=?: T-2
GSTART
```

K-2 READING PHONICS

---

OLD McDONALD'S  
FARM VOWELS

---

A game like drill program to present long and short vowels with words, pictures and spoken messages. Teacher generated for home and school. Five challenging levels with scoring, rewards and reinforcement.

For COCO Color Computers with 16K Ext. Color BASIC & cass. OMF \$14.95 + 2.00 shipping VISA & M.C.



RAINBOW  
CERTIFICATION  
SEAL

---

TEKSYM CORPORATION  
14504 County Road 15  
Minneapolis, MN 55441



## A WORD FROM THE SPONSOR

Welcome to the fourth of my monthly chats with readers. Judging from my mail, this is proving to be a popular feature of our Star-Kits ads.

How often have you wished that you could see a program work before you bought it? We have come up with a way for you to do just that . . . if you have a video cassette recorder.

To show you what our programs do, we have prepared a demonstration tape which puts each of our programs through its paces so you can see exactly what it does and how. We're not professional movie producers so it's not quite up to Hollywood standards, but it does provide a complete and thorough demo of each of our programs, better than you might get in a computer store.

The tape is available in either VHS or Beta format and costs \$20. If you return it, you get full credit toward any purchase. If you decide not to buy our software (not too likely once you see it work), then just erase the tape and reuse it.

Another way to evaluate products is through magazine reviews. Here is a listing of recent reviews of Star-Kits products: HUMBUG — Color Computer News in February 1983, Rainbow in May 1982, and 68 Micro Journal in June 1982. STAR-DOS — Rainbow in February 1983, and 68 Micro Journal in January 1983. SPELL 'N FIX — Rainbow in July 1982, 80 Micro in November 1982, and 68 Micro Journal in July 1982. NEWTALK — Rainbow in June 1982. You will also find reviews in MICRO Magazine, InfoWorld, and elsewhere.

Here's a note to HUMBUG owners. If you are using HUMBUG with a disk system, then single-stepping or breakpointing a program may occasionally prevent Basic from turning off the disk motor. To avoid the problem, change the five bytes beginning at location 3B1A from 10 EF 8D 03 CB to A6 E4 1F 8A 12. HUMBUGs shipped after February 1, 1983 already have this change made.

One of our customers bitterly complained the other day — in fact, accused us of fraud — for shipping him Spell 'N Fix on a copy-protected disk, but not mentioning it in our ads. After taking umbrage at his letter, I decided to devote part of this column to the subject.

We all know that "lending" programs among friends is common. It's difficult to say "No" to a good friend. The problem is that some people can't even say "No" to strangers. I've recently come across a salesman in a computer store who is giving away commercial programs to total strangers just so he can sell more computers. I have also seen a computer club send out a list of "free" software by mail just so they can sign up a few more members.

Consequently, most software houses now copy-protect their disks or tapes. We do it with Spell 'N Fix, and so do most of the other major software houses that advertise in this magazine. Frankly, it costs us time and money to do it, and we don't enjoy it. Yet we have to. People who would never steal a \$70 watch don't hesitate to steal a \$70 program. Believe me, from the victim's point of view they both hurt equally much.

Maybe we all need a little more practice saying "No!"

After all, if God had meant to endorse this kind of thing, He would have given us the Ten Suggestions.

See you next month.

*Peter Stark*

## SPELL 'N FIX

Regardless of whose text processor you use, let SPELL 'N FIX find and fix your spelling and typing mistakes. It reads text faster than you can, and spots and corrects errors even experienced proofreaders miss. It is compatible with all Color Computer text processors, including Telewriter and Radio Shack's Scripsit! (See the review in 80 Micro, November 1982.) \$69.29 in the Radio Shack disk or cassette versions; \$89.29 in the Flex version. (20,000 word dictionary is standard; optional 75,000 word Super Dictionary costs \$50 additional.)

## HUMBUG — THE SUPER MONITOR

A complete monitor and debugging system which lets you input programs and data into memory, list memory contents, insert multiple breakpoints, single-step, test, checksum, and compare memory contents, find data in memory, start and stop programs, upload and download, save to tape, connect the Color Computer to a terminal, printer, or remote computer, and more. HUMBUG on disk or cassette costs just \$39.95.

## STAR-DOS

A Disk Operating System specially designed for the Color Computer, STAR-DOS is fully compatible with your present Color Computer disk format — it reads disks written by Extended Disk Basic and vice versa. But with STAR-DOS you can use machine and assembly language programs to do things Basic can't. Just \$49.95.

## ALL IN ONE — Editor Etc.

Three programs in one — a full function Editor for text or program files; a Text Processor for formatting and printing text files with centering, justification, and paging, and a Mailing List and Mailing Label program which can even generate individually addressed letters for each person (or selected persons) on your mailing list. All this for just \$50. Requires STAR-DOS and 32K.

## DBLS for Data Bases

DBLS stands for Data Base Lookup System. A super-fast system for searching for a selected record in a sequential disk file. Supplied with SPELL 'N FIX's 20,000 word dictionary as a sample data file — lets you look up the spelling of any word in under FOUR seconds. Priced at \$29.95. Requires STAR-DOS.

## CHECK 'N TAX

Home accounting package combines checkbook maintenance and income tax data collection. Written in Basic for either RS Disk or Flex, \$50.

## REMOTERM

REMOTERM — allows full operation of the Color Computer from an external terminal. \$19.95.

## NEWTALK

NEWTALK — a memory examine utility for machine language programmers which reads out memory contents through the TV set speaker. \$20.

## SHRINK

SHRINK — our version of Eliza, in machine language and extremely fast. \$15.

## OXXO

OXXO — our version of Othello, also machine language and fast. \$15.

We accept cash, check, COD, Visa, or Master Card. NY State residents please add appropriate sales tax.

# STAR-KITS

P.O. BOX 209 — R  
MT. KISCO, N.Y. 10549  
(914) 241-0287

**\*\*PEEKs AND POKES\*\***

Hello again. This month we'll have some more on peeks and pokes, but first the commercial. By the time this ad hits, ZAXXON will be available for the CoCo, and PCLEAR 80 will have it. Call or write for details.

One excellent use of PEEK is to find the addresses of machine language programs. PRINT PEEK(157)\*256+PEEK(158) to get the start location; PRINT PEEK(487)\*256+PEEK(488) to get the beginning; and PRINT PEEK(126)\*256+PEEK(127) for the ending.

To save wear and tear on your on-off switch, type POKE 113,0 and press the reset button. This will give you a cold-start.

We went to this type of ad this month because we thought that you, like us, get tired of seeing endless lists of software. And, frankly, we're too small to compete with the folks taking out full-page ads and offering glossy catalogs. But we can offer you one thing--total dedication to the Color Computer and CoCo owner.

And we do have a fine list of CoCo products to choose from, including DONKEY KING, TELEWRITER, PLATINUM WORKSAVER, and the only under \$200.00 HARDWARE speech synthesizer available anywhere. We also stock many back-issues of RAINBOW.

So order from our Feb. ad or send \$.50 for our full catalog (refundable with order). And look for our ad next month for some more PEEKs and POKES.

Special thanks to the International Color Computer Club who provided much of the info on PEEKs & POKES.



**PCLEAR 80 SOFTWARE**



**494 Cline Avenue  
Mansfield, OH 44907  
(419) 756-4873**

Note: We also carry the RAINBOW



Add \$2 shipping on orders less than \$50. Please add \$2 for COD. Ohio residents add 5% state sales tax.

**\*IRVING**

```
ROB> =R:XL:CMIS:CRAND:GROB
WAL> =W:T-5:F8:CR0B:GWAL
RAND> =?:T-2:F6
LOOK> =S:T-1:CR0B:CWAL:GLOOK
MIS> =?:XM:CDLAY
DLAY> B1:F1:B1:F1
START> CR0B:CWAL:F8=?:T-2
CLOOK
=?:T2
GSTART
```

The main loop of the program begins at START. Here's a translation of Fred's main program loop: Call ROB, call WAL, forward 8, once-in-a-while turn 45 degrees right, call LOOK, once-in-a-while turn 90 degrees left, then return to START. All the searching and firing of missiles and lasers is embedded in the sub-routines.

When you've edited a program and are ready to see it operate, you must have the computer *compile* it. Compiling is almost instantaneous. When you call BATTLE, your robots will be ready to go at the touch of a number key. Which key you touch will determine the speed of execution of your programs. A number 1 is the fastest available speed, while #9 is an absolute snail's pace. You can also single step through the routines by using the 0 key.

Considering that the programs are compiled, I'm surprised at the relative slowness of movement, even at the "fastest" speed. It takes quite a while for a robot to use up his available energy (taking hits, firing weapons, bumping into things, etc., all use varying amounts of energy), leaving the other robot victorious. Two major things I'd wish for in this program: faster speed and an option to design your own robots.

The ultimate test is if the program is doing what I thought it would do when I bought it. Does it really teach programming methods and structures? I think so, but only time will tell. Does it intrigue enough to draw the kids to it? Well, in competition with *Donkey Kong* and *Defender* and *Centipede*, it doesn't stand too much chance, but the 11-year-old is a little more intrigued by the idea of learning programming than the 13-year-old video-game wizard is, and he *has* spent a couple of self-motivated sessions on it.

(Radio Shack, Nationwide, cat. #26-3070, \$39.95)

—Paul S. Hoffman

Hint . . .

## Painting Must Be Accurate

When you issue a PAINT command, be sure that you set the point at which the PAINTing is to begin within the area that is to be PAINTed. If you set the position on a line which encloses the area, the PAINT will not work.

Also, when using PAINT, be sure that your area is fully enclosed, or the PAINT will "leak" out and cover the entire screen.

# INTERNATIONAL COLOR COMPUTER CLUB

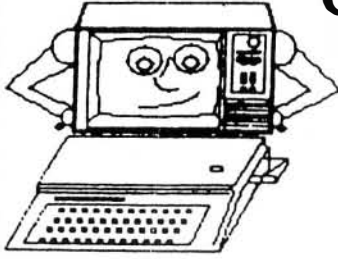

Main Office  
2101 E. Main St., Henderson, Texas 75652  
Canadian Branch  
96 Carleton Dr. Saskatoon, Saskatchewan S7H-3N6

**WORLD'S LARGEST COLOR COMPUTER CLUB**

## HERE ARE SOME GOOD REASONS FOR JOINING

- 1). **FREE PROGRAMS.** Good programs written by our members are contained in the library, in the newsletter, and on the new member tape.
- 2). **NEWSLETTER.** A "magazine" sized newsletter (last issue 80 pages), with programs, tips data, reviews, articles and much more.
- 3). **NEWSLETTER Tape** A tape of all the programs appearing in the newsletter is available from the library for \$2.00 (to members)
- 4). **CLUB LIBRARY.** The club maintains a library of programs, books and Radio Shack ROM-packs. The programs are member written and are yours to keep, there is a small fee to cover postage and tape (\$2.). The books and ROMpacks may be checked out for 3 weeks at a time. (extencions possible)
- 5). **DISCOUNTS.** get large discounts on many software and hardware items for CoCo from some of the MAJOR companies. Also discounts on subscriptions to the RAINBOW, CCN and Chromasette magazines.
- 6). **ADVERTISE FREE** Members may place ads of up to ¼ page per issue in the newsletter FREE. (The ad must be computer related)
- 7). **BORROW PARTS.** Don't wait weeks for the parts to come in from Radio Shack! Just check them out of the Clubs Parts library and return when yours arrive.
- 8). **SURPRISE.** You receive a "New member" package containing many useful items.
- 9). **GET HELP.** This is the worlds largest Color Computer Club. With members in almost every field of expertise. So if you have a problem with the Color Computer, we can almost always get you the answer. Put your problem on the Clubs Bulletin Board, write, or call.
- 10). **FIND FRIENDS** As a new member, you will receive a list of the members in your area whom you may contact for CoCo talk.

## HOW TO BECOME A MEMBER:

Write to the club for an application, there are no conditions for membership other than agreeing to obey the rules, being interested and paying the dues. The membership dues are \$30.00 per year and we believe you get more than your moneys worth. You can save more than the \$30.00 in discounts the club offers you. Example: Subscription to the RAINBOW, 25% off of regular subscription rates. Some members have told me that the new member tape alone is worth the \$ 30. it contains 10, very good programs. Some of the programs contained in the library are, Accounts Receiveable, General ledger, Inventory, Sales file and ticket program with automatic Inventory update (for 32 K with 2 disc.)









# NEW for your COLOR COMPUTER

## Release the potential of your Color Computer . . .

Use up to 5 compatible Color Computer cartridges at the same time with the BT-1000 Expansion Interface Unit.

- **The BT-1000 is limitless combinations.** Plug in your disk controller, memory boards, Real Time Clock/Calendar, printer interface, experimental boards—all at one time.
- **The BT-1000 is adaptable.** Up to five functional peripheral cartridges, in your choice of combinations, will run with any configuration, any size memory of the Color Computer.
- **The BT-1000 is flexible.** Four 24-pin sockets hold up to 8K static RAM or EPROM (can be supplied with an extra 8K RAM).
- **The BT-1000 is safe.** It will not overload, overheat or damage your Color Computer in any way.
  1. Has own built-in power supply.
  2. Effectively isolated by a buffered cable.

## That's not all Basic Technology has to offer . . .

Record date and time on all programs, files, letters, with the accurate, programmable BT-1020 Real Time Clock/Calendar.

- Plugs into your BT-1000 or directly into the Color Computer expansion slot.
- Adds day, date, month, year, hours, minutes, seconds (12/24 hr.)
- Includes internal NiCad battery, crystal controlled to 0.001% accuracy (charges when your computer is on)
- Has 50 bytes of battery backed general purpose memory

## All Basic Technology components are first-line quality.

- gold board-edge connectors
- glass epoxy PC boards
- 180-day full parts and labor warranty on all components



Your **Basic Technology** components arrive assembled, tested, ready to plug in and turn on. A comprehensive User/Service Manual is included with complete schematics, PC component layouts, parts lists and hints on mapping your peripheral add-ons anywhere in the CPU addressable memory. Write for free brochure.

BT-1000 incl. cable \$270      BT-1020 Clock/Calendar \$109  
BT-1000 w/8K RAM \$300

Add \$5.00 shipping & handling for BT-1000, \$2.50 for BT-1020. Michigan residents add 4% sales tax. Shipping & handling for residents of Canada, Hawaii, Alaska is \$10.00. Overseas orders add 15%. Check, money order, VISA, MC (give account no., expiration date, phone no.). Personal checks allow 2-3 weeks to clear. COD charge \$2.00 (requires certified check or money order).

*"Watch for more peripherals from Basic Technology."*

**basic**  
**TECHNOLOGY**

Dept. Q P.O. Box 511 Ortonville, MI 48462

(313) 627-6146

# How To Reduce That RFI On Your Monitor

By  
Tony Distefano

First of all I would like to clear up a problem with the "Finger Saving Rapid Fire Circuit." The potentiometer in the Parts list has the wrong part number. It is not *the Rainbow's* fault, it is mine. You see, when I first made this circuit, it was indeed a 100k ohms pot, like the part number stipulates. But I thought the firing speed was not variable enough, so I changed the pot to 1 Mega ohms. If you have already bought the 100k ohms pot, do not despair, it will still work. The only difference is that the firing speed will not go as slow as the 1 Mega ohms one will. Radio Shack does not have a 1 Mega ohms pot in that package, so I cannot give you another part number for it. Almost any other electronic hobby shop should have it, though.

Okay, let's get on with this month's project. One of the problems with some of the older Color Computers is that when you plug in a disk drive, you get a lot of noise on the screen. The type of noise I am talking about is not a buzz from the speaker, but a type of wavy, herringbone pattern that seems to swim across the screen at a regular rate. Yes, that is "RFI." That stands for Radio Frequency Interference. I talked a little about RFI in the January '83 issue of *Rainbow*. It is very annoying to see this noise going back and forth on the screen all the time. Fortunately, there are a few things you can do to eliminate it.

One of the things you can do is this. Open the door and look inside the cartridge port. On both sides of the connector there should be metal clips. If there aren't, your local Radio Shack Repair Center can put them in for you. Apparently they will do this at no charge. I guess you will have to find this out for yourself. What this does is, when you have a disk controller plugged in, the clips act as extra ground connections. This prevents the controller from acting like an antenna.

Another way to reduce the RFI in the Color Computer is to get the aluminum shield from Radio Shack (again!). This shield fits under the keyboard. It snaps into the main board between the plastic standoffs and the board. The rest goes under the keyboard without any other connections. This extends the ground plain that is under the main board to the keyboard, too. The third way, and the main topic of this month's article, is to modify the TV that you are using with the Color Computer.

Before you start digging into your TV set, I'll give you a little background on how the signal gets from the Color Computer to the tuner. It starts from the connector in the back of the computer. It then goes down a shielded piece of wire to the connector box supplied by RS. This is a switch box which allows you to connect your antenna to it and switch back and forth between regular TV signals and the computer without disconnecting anything. **THIS BOX IS A BIG SOURCE OF NOISE!** Get rid of it immediately! RFI can seep through that box like water through a screen door on a submarine. It is best to get rid of the wire that RS supplies too. You must make your own wire. This is not hard. Buy the four-foot white coax cable from RS part #15-1529. On one side, push on one of the F-56 connectors (supplied with the kit). On the other side install a Shielded Phono Plug, RS part #274-321. That is the end that goes into the computer. If your TV set has only the two screw type terminals you will need a F-61 connector as well, RS part #278-212, (more on that later).

So far, what you have done should reduce the RFI by quite a bit, but if there is still RFI coming in you must modify the insides of your TV. The next step requires that you remove the back of your TV. Only experienced hackers should take off the back of a TV. There are high voltages present in there. If your TV is like mine and most TV sets, the antenna connections are done via a small circuit that isolates the ground of the TV to the antenna. This is done to prevent electric shocks, because since there is no power transformer, one side of the AC line is directly connected to the internal ground. Touching the ground of the TV is like touching one side of a plug. Nothing will happen until you touch a ground point like the third pin of a three-prong plug or a water pipe. The Color Computer is grounded with a three-prong plug. If you try to connect them, watch out. Then you will see all the sparks fly. This is why the manufacturer of the set put a high impedance circuit to isolate the line from the antenna input. A small circuit is a lot less expensive (and a lot lighter) than a power transformer. Unfortunately this circuit is very sensitive to RFI. You have to remove this circuit and connect the antenna terminals directly to the tuner.

SUPERIOR ORACLE SOFTWARE  
PRESENTS  
**THE C C QUBE**  
A MAGIC CUBE SIMULATION FOR THE COLOR COMPUTER

FEATURING:

- Easy to use commands
- Fast - uses machine language routines
- Random mixes
- Undo moves or random mixes
- See all 6 faces
- Save QUBE to tape for later reload
- Only \$14.95



Send Check or M.O. to:

SUPERIOR ORACLE SOFTWARE  
P.O. Box 3505  
Greenwich, Conn. 06830

Conn. residents add 7 1/2% sales tax  
Shipping and handling included

Personal checks require  
2 weeks to clear

No C.O.D.s

Requires 16K Extended Basic



# RAINBOWfest

April 22-24, 1983

## CoCo's Very First Show!

CoCo has grown up and it's time for CoCo's very first show. Sponsored by *the Rainbow*, the premier magazine for the TRS-80 Color, TDP System-100 and Dragon-32 computers, RAINBOWfest will be *the* place to be this Spring.

Exhibits will abound. Information will flow. New products will be shown and introduced. Many of the "names" in the CoCo world will be in attendance. It all boils down to three days of fun, excitement and learning for everyone lucky enough to own a CoCo (or those who just wish they did)!

The place is the Regency-Hyatt Woodfield, located on the western outskirts of Greater Chicagoland, within easy access to highways and O'Hare International Airport.

The dates are April 22-24.

The times are 7-10 p.m. Friday; 9 a.m.—8 p.m. Saturday; and 10 a.m.—5 p.m. Sunday at the Grand Ballroom.

The cost is only \$7.50 for a three-day ticket in advance or \$11 for a three-day ticket at the door. One-day tickets are \$5. in advance or \$7.50 at the door.

A Saturday "let's make friends" breakfast is also planned. Cost of \$10 includes breakfast and a speaker—someone well known in the world of Color Computers.

Rooms are available at the Regency-Hyatt Woodfield for a special RAINBOWfest rate of \$43 per night, single or double occupancy.

Admission tickets, breakfast tickets and reservation cards for the hotel can be secured directly from *the Rainbow*. Mail the form below to *the Rainbow*, P.O. Box 209, Prospect, KY 40059. Advance sale tickets will be sent by return mail up until April 15. After that, they will be available at the door.

Oh yes...for the "others" who (perish the thought) don't get into CoCo like you do, Woodfield Shopping Center directly adjacent to RAINBOWfest is the world's largest enclosed shopping mall. And, you are only a short drive from downtown Chicago's museums, theatres, aquarium and shops.

RAINBOWfest has it all! Don't miss CoCo's very first show!

### PLUS . . .

*Seminars Saturday and Sunday on all aspects of CoCo BASIC classes for all*

Breakfast Speaker . . .  
**DON INMAN**  
Author and Rainbow Columnist



YES, I'm coming to CoCo's very first show! Please send me:

\_\_\_\_\_ three-day tickets at \$\_\_\_\_\_ total \_\_\_\_\_  
 \_\_\_\_\_ one-day tickets at \$\_\_\_\_\_ total \_\_\_\_\_ (specify day) \_\_\_\_\_  
 \_\_\_\_\_ breakfast tickets at \$10 total \_\_\_\_\_  
 handling charge \$1.00

TOTAL ENCLOSED (U.S. FUNDS ONLY, PLEASE)\$-----

- Also send me a reservation card for the Hyatt-Regency Woodfield.

NAME \_\_\_\_\_  
 STREET & NUMBER \_\_\_\_\_  
 CITY & STATE \_\_\_\_\_  
 TELEPHONE \_\_\_\_\_ ZIP CODE \_\_\_\_\_  
 COMPANY \_\_\_\_\_

Advance Sale ends Thursday, April 21. Orders sent after April 15 will be refunds on tickets.

Make checks payable to:  
**the Rainbow**

MAIL TO:  
RAINBOWfest  
P.O. Box 209  
Prospect, KY 40059

The first thing you must do before you take out the circuit is to add in a transformer to isolate the line. The transformer must be a *line isolation transformer*. Your local electronics-store should have one. The power rating of the transformer must match the power rating of your TV. It is usually written on the back of the set, or in the operating manual. Now, remove the back from the TV and mount the transformer somewhere inside, with the proper mounting hardware. Cut the AC cord that runs inside the set. If your set has a removable cord, cut the wires from the internal side of the connector. Re-route the AC side of the two wires to the input of the transformer and route the output of the transformer back to the TV input. This will isolate the ground from the AC line. I cannot emphasize enough the need for this transformer; if you don't put it in and you remove the circuit, you stand the chance of burning out your TV and your computer. Then you won't have to worry about RFI, only fire. Enough of this, now it's time to remove the circuit.

Unsolder the circuit from the antenna terminals. If the terminal is not the cable TV type, drill a hole and mount the F-61 connector. The other side of the circuit is usually a shielded wire that leads to the tuner. Cut the wire as close to the circuit as possible. Strip off the insulator and solder the inside wire to the tip of the F-61 connector. Solder the shielded part to the outer part of the connector. This will connect the antenna terminal directly to the tuner input. Before you plug in the TV, a little check is in order. With an ohm meter, and the TV on (but not plugged in) measure the resistance between the AC cord and the antenna terminal. Test both wires. If they read high impedance you are in business, if not, then check the wiring again. There should be no shorts between the AC cord and the antenna terminals. Replace the cover and try it. There you are, a clean picture.

# COLOR COMPUTER WEEKLY

NEW!

CAN YOU AFFORD \$1 A WEEK?

The CCW Newsletter will give you this if you can:

- An issue loaded with program listings of all sorts (for just a buck a week—unbelievable)!
- Latest news and information — if it happens on Monday you'll know about it by Friday (for a mere 100 cents a week)!
- Mailed out to you first class every week! (At last a reason to live from week to week)!
- Free software/hardware manufacturer's directory (This alone is worth the price of the subscription, and we even send regular updates to subscribers.)!

All it takes is ten thin dimes a week to bring meaning to your life. Cumulatively we'll take payment in the following ways:

- Charge my Visa or MasterCard at once for the full amount (\$52/year)
- Charge my Visa or MasterCard quarterly at the rate of \$13 every three months
- Here's my check for \$14 for the first quarter, bill me in three months for the next quarter (we have to charge you extra to send out those bills)
- Here's my check for \$52 for the full year hurry and send me my first issue

Name \_\_\_\_\_  
 Address \_\_\_\_\_  
 City \_\_\_\_\_ State \_\_\_\_\_ Zip \_\_\_\_\_

Visa    MC   Exp. Date \_\_\_\_\_ # \_\_\_\_\_

Tiny Signature \_\_\_\_\_

Send to: CCW • P.O. Box 1355 • Boston, MA 02205

Software Review . . .

## Bridge Tutor I: This Partner's No Dummy

*Bridge Tutor I* is one of the latest offerings from Radio Shack in the ROM Pak department. As a former grand master of the lunch players bridge society, I was very interested to see how I could do against a computer. Well, we'll get to that later.

*Bridge Tutor I* comes with an 83-page instruction manual which makes the package somewhat larger than the standard ROM Pak. The documentation is well written and in a very well organized format. The manual is divided into four sections. The first section tells you how to use the program. The second part provides a commentary on each of the 100 pre-programmed hands. The third section covers the fundamentals of bidding and playing for novices. The fourth part is a summary of operations of keys. No problems were encountered with the program, but it is complicated enough that you must read the first section of the manual to become familiar with the operation.

The program will run on a 4K non-extended basic computer. Joysticks are optional.

After inserting the ROM Pak and turning on the computer, you will see a logo of the hand you are playing. The hands are numbered from 1 to 100 and arranged in order of increasing difficulty. Each hand is supposed to offer a unique offensive or defensive strategy. The arrow keys control the majority of functions, or the joysticks if you desire.

After picking the hand of your choice *ENTER* will initiate the dealing of the cards. I think this is a program in itself in that the cards are dealt into four separate hands and *the player's hand is sorted for him* according to suits and rank.

The bid is increased by "up-arrow" until the bid of your choice is selected by *ENTER*. An incorrect bid will be noted and not accepted.

The following keys have special functions: "A"—advice, "F"—fast deal, "S"—score, "R"—review, and "J"—joystick.

After the bidding is completed, you are given the choice of which hand you wish to play. The game starts automatically unless you are in the west position, in which case you have to lead.

Play is continued by picking the card of your choice by means of the "left-arrow/right-arrow." Incorrect plays are noted and you are also congratulated for "crucial play." You are scored at the end of each game for the percentage of correct plays.

The only problem I had with the program is that it wouldn't let you make a mistake. As in most everything I do, I have my own way of playing bridge. It must be somewhat unusual, as I had several occasions where I disagreed with the *Bridge Tutor I* "expert." My neighbors have a competitor's version of bridge and it doesn't comment on the hands, letting you fend for yourself. Fixed bidding, as in *Bridge Tutor I*, is a big advantage for the novice but somewhat frustrating for the advanced player. Maybe that's why they named it *Bridge Tutor* instead of *Bridge Expert*!

In conclusion, I think the game is fun and interesting. I recommend it to novices and experienced players alike. Now, if only they would add a synthesized voice that shouts "what a play!" or "you dummy!"

(Available at Radio Shack stores for \$34.95)

—Dan Downard

The Programmer's Guild Presents . . .

# PAC — DROIDS™

BY  
*Charles Forsythe*

## THE ULTIMATE IN PAC-ACTION

ONLY \$19<sup>95</sup>

UP TO FOUR PLAYERS!!

*Unlike Any Other "PAC" Game You've Ever Seen!!  
Hot Machine Language Multi-Color  
High-Res Graphics For All 16K  
TRS-80 Color Computers*

**MORE SOUND — MORE ACTION  
MORE FEATURES THAN ANY  
"PAC" GAME IN EXISTENCE!!**



Try PAC-DROIDS™ for the Outer Limit in pure,  
explosive arcade action!!

SEND \$19.95 CHECK/MONEY ORDER or VISA/MC NUMBER  
TO

**THE PROGRAMMER'S GUILD  
P.O. BOX 66  
PETERBOROUGH, NH 03458  
—or Call (603) 924-6065 for COD—**



*AND GET "FREE" SHIPPING ANYWHERE ON THE PLANET  
EARTH OR HER COLONIES*



## Death Star: Recommended Adventure, Impressive Package

You are the rebel fighter given the task of rescuing Princess Leah from the *Death Star*. This one-player Adventure gives you the choice of either novice or pro modes (advice: novice is playable while pro is guaranteed death even for an experienced adventurer).

This 32K Extended Color BASIC text Adventure is a nice introduction to the logic and flow of an Adventure game. It is Carl Shell's first attempt at this type of program. The flow and play of the game is adequate, but it lacks some of the frills of the very best advanced games. The following critique is designed both to give a description of the game and to give guidelines to players who would like to edit the program to suit their own tastes.

*Death Star* uses Sugar Software's *Auto Run* to create an appealing title page. After this, however, expect mostly text and a few screen color changes. Along with graphics I should mention the sound effects. The sounds are pleasant at first, but soon become annoying. They remind me of a Navy alarm buzzer.

The game package includes one program tape, one page of hints, and one page of instructions (no more instructions are needed since the program is self-explanatory). The 5½" x 8½" hard vinyl case which stores all of this is very impressive. It is more appealing to look at a nicely designed case than a mere cassette box lying on my desk. It adds a touch of professionalism to my library.

The object of your mission is to find the power pak, rescue Princess Leah, and then find the escape module. You have eight enemies (four are weak and are used to gain credits, while four are strong and are used to hold the princess). The power pak and escape module are just lying around. All you tumble upon these. Rescuing the princess is another thing. You to do is to smust defeat the hard foe who holds her captive; however, you do not know which one has her. After you find the power pak, rescue Princess Leah, and find the escape module you have finished the adventure.

In the novice mode, you start with 1,000 credits, 300 hit-points, and 50 units of oxygen. You use your credits to buy weaponry, armor, more oxygen, and hit-points, and various forms of help from Yoda. Don't expect to buy everything at first. You must wait until you do battle and earn more credits. You can earn hit-points by spending a few nights at the sleep port.

The first thing you should do after arriving at the teleport gate is visit the weaponry shop. While there you should purchase a gravity pak and a weapon. Your choice of weapon is not important as long as you also buy the enhanced weaponry capability from Yoda (hint from Yoda: Do not trust your impulses. Trust the force). Next is armor. Use your own discretion when buying armor. Enhanced armor is nice, but not mandatory. It is very helpful if you seek help from Yoda. You can purchase potions to prevent blindness, sleep, poisoning, and in some cases, body damage. You may also buy a favor from Yoda to collect upon when a tragedy befalls you. (A "favor from Yoda" can turn a sure mortality into a good laugh. A nice touch!) As for the extra oxygen and hit-points, all that can be said is to obtain these when you think that you need them. After you play a few times you will find a combination that you like best.

The logic of the game is very simple. Single alphanumeric character inputs control all movement and actions. This feature makes the game easy enough for children, but in long play, it can become repetitious. No map is needed since there is not a pattern of events set by the program. Random numbers control the play of the game. If Lady Luck is not on your side, you could be searching for hours before you would find the things you need (here's where you will wish that you did need a map). I suggest that if play lasts longer than two hours, start over. If you need help, Carl Shell very generously offers his phone number in the documentation, suggesting you call him between 6:00 p.m. and 11:00 p.m.

In conclusion, I recommend *Death Star* to either gamers who have never played adventures before or to more experienced players like myself who would like to edit and adapt a BASIC Adventure to their own tastes.

(S & S Arcade Supplies, 8301 Sarnow Dr., Orlando, FL 32807, \$19.95)

—John R. Curl



COMPUTER PROGRAMS  
TRS-80 MODEL 1/3 16K LEVEL II  
TRS-80 16K COLOR

---

\$3 FROG RACE \$3  
DEMO PROGRAM FROG RACE COMES ON CASSETTE WITH A REFUND COUPON TO USE ON YOUR NEXT ORDER.  
FROG RACE CASSETTE \$3. WITH CATALOG

---

DUO-PAKS ARE \$10 EACH.

PAK NO.	PROGRAM SIDE 1	/	PROGRAM SIDE 2
DUO-PAK-1	GONE FISHING	/	CONCENTRATION
DUO-PAK-2	CRAPS	/	SLOT-MACHINE
DUO-PAK-3	STARSHIP	/	SHERLOCK HOLMES
DUO-PAK-4	TANK ATTACK	/	ASSOCIATION
DUO-PAK-5	NUMBER GUESS	/	DICE ROLL
DUO-PAK-6	IN-BETWEEN	/	SHELL GAME
DUO-PAK-7	SAFARI	/	STARSHIP-2
DUO-PAK-8	MORTAR BATTLE	/	PUZZLE
DUO-PAK-9	TEASERS	/	MOUSE
DUO-PAK-10	PT BOAT	/	TURTLE RACE
DUO-PAK-11	CHEK-CHEK	/	STARSHIP-3
DUO-PAK-12	THINK	/	LUCK & LOGIC
DUO-PAK-13	TREASURE ISLAND	/	RESCUE
DUO-PAK-500	DC-OHMS LAW	/	FLC-FRC
DUO-PAK-501	IC-TIMER-1	/	IC-TIMER 2

---

\*\*\*\*\*  
SYSTEM PROGRAMS \$10 EACH

---

SU1 CASSETTE COPY / CASSETTE COPY  
\*\*\*\*\*  
ORDERS WILL BE SENT BY FIRST CLASS MAIL PPD.  
SORRY NO COD'S  
BE SURE TO SPECIFY WHICH COMPUTER YOU HAVE.  
B. ERICKSON P.O. BOX 11099  
CHICAGO, IL. 60611

Hint . . .

### What ROM Have You?

All CoCo's come up with a message which says you are operating with version 1.0 of the operating system. How can you tell whether you have a version 1.0 or 1.1 of the Basic ROM chip?

The answer is a simple one: Just type in EXEC 41175 and the version of your ROM will appear on the screen.

# The PROFESSIONAL Keyboard

A direct plug-in replacement for your Color Computer.

- \*Simple Installation  
(No glueing or cutting)
- \*Redefinable Keys  
(Free Software Included)
- \*No Extra Charge for TDP/F Model

**\$ 89.95**

"A Model 1 keyboard in a Color Computer case. This product is a real gem."  
*Rainbow Review*, March 1983  
\*All TDP/F orders please specify

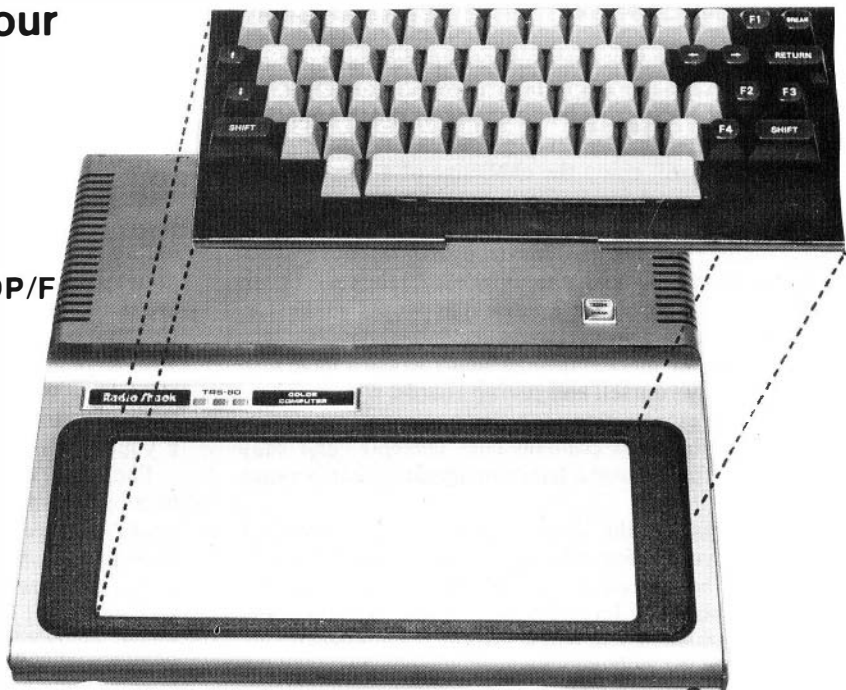

## SPECTRUM SWITCHER

by T.J.N. SYSTEMS

**\$ 99.95**

Have your Disk and Cartridge too!  
Transforms a Color Computer into a dual slot system. Comes with extender cable.

---

## SPECTRUM PROJECTS

93-15 86th DRIVE WOODHAVEN, NY 11421  
212-441-2807

all orders plus \$2 S/H, N.Y. residents add sales tax

## Beware of the Fembots Beyond the Cimeeon Moon

If you're a novice at Adventure games, you have to have suicidal tendencies to play *Beyond the Cimeeon Moon* because you will experience the agony of death countless times. The advanced Adventure game player, on the other hand, probably will enjoy the challenge of a game that is breaking new ground for CoCo.

The game combines the magnetism of colorful arcade-like graphics—along with the need for strong hand-to-eye-to-keyboard coordination—and the intellectual appeal of an Adventure game to create a saga that would make Dr. Spock break out in a sweat.

You are in outer space trapped aboard an alien slave ship occupied only by yourself and roving guards, who are there to prevent your escape. You are pitted against an omnipresent machine mind that controls the "fembots" and only rapidly typing fingers and a fertile imagination can prevent your demise.

For some reason, the door to your cell has been left unlocked and your mind, which has been enslaved for several years, has been freed, so there is finally a remote chance of escaping the multi-leveled vessel. There will be many times, however, when you will yearn for the comparatively safe confines of the cell.

You quickly discover that the halls are being patrolled by fembots and they show up when you least expect them. Sometimes they zap you before you've even seen them. Then there are times—if you can type quickly enough—when you can run right over them, a fact I discovered out of desperation.

A rich assortment of basic necessities have been left behind by the aliens, including such things to wear as vacsuits, armor, powersuits with armor, and shield belts—which can be found throughout the ship if you search long enough. There also are such weapons as lasgun lasers and mauler rifles, which have been slipped into out-of-the-way crannies, as well as some disc decoders.

As you "tour" the ship you will discover that there are many mysterious rooms—a number of which appear to be empty at first glance, but which contain items essential to your escape, if you know how to search them. Many of them are in fact empty but, upon entering them, you're likely to find that someone or something has locked the door behind you. Don't panic, though, because pressing the shift and clear keys simultaneously, along with any other key, will teleport you back to your cell. (You will discover this early, if your experience is similar to mine.)

Each floor contains teleportation pads which enable you to move from one floor to the next with relative ease. Be ready to move quickly, however, when you get to the next floor because the fembots are everywhere.

The creators of the game are kind enough to provide you with a series of I I commands that should make playing a lot easier. There's an "inventory" command that lets you check your energy supply and the equipment you have picked up along the way. Your energy supply dwindles every time you are shot, but you can be shot eight times before it's used up and you are wasted. Thankfully, there are places in the vessel where you can have your energy restored.

Enter a wrong command and all you get is an "Oopie!" or "Error" message. I think the "Oopie" signal is supposed to add a little levity, but I didn't think it was so funny after seeing it more than 50 times. Nor did I enjoy the hundreds of trips I made up and down the halls searching for the faintest clue of a solution to the game.

I was impressed by the three-dimensional graphics and the surrealistic sound effects. You do get the feeling of actually being inside the spaceship and it is not difficult to find your way around using the arrow keys. I also liked the window I found on the third floor of the ship; it was refreshing to see the stars twinkling after so many blank walls and empty rooms.

There are many solutions to the game and, if you're among those lucky enough to find a couple of them, you're ready for some of ColorQuest's other 3-D games, such as *Fembots' Revenge* and *Adventure Trilogy*. If you are smart enough to solve *Beyond The Cimeeon Moon*, that is. On a scale of 1 to 10 in Adventure games that I have played, I would give this one a "nine."

If Adventure games are your bag, *Beyond The Cimeeon Moon* is for you. Now, where is that leader. . . ?

(ColorQuest, a division of Softlaw Corp., 9072 Lyndale Avenue South, Minneapolis, MN 55420, 16K tape \$24.95, 32K disc \$29.95)

—Charles Springer

**TAKE THE GUESSWORK OUT OF  
STOCK & FUND  
INVESTING**

FUNDGRAF is a new computer program which not only graphs and analyzes funds or stocks, but also makes decisions on when to buy and sell. Use your TRS-80 Color Computer (TM Tandy Corp.) as a valuable investment tool.

- GRAPHS the progress of your funds or stocks
- SUPERIMPOSES for comparison:
  - a line of constant percent growth
  - a graph of any other fund
- CALCULATES over any given time span:
  - percent price change
  - the moving average
- INDICATES BUY and SELL signals



**Tape version compares stocks or funds in groups of seven for up to 70 weeks.**  
--- \$49.95

**Disk version compares any 36 funds on one disk for up to 200 weeks.**  
--- \$69.95

-Sample data and detailed instructions furnished.  
-Both versions require 16 K Extended Basic.  
-For more information send S.A.S.E.  
-For your FUNDGRAF program send the price indicated above plus \$2.00 handling to:

**PARSONS SOFTWARE, DEPT. A  
118 WOODSHIRE DRIVE  
PARKERSBURG, WV 26101**

FUNDGRAF - A STOCK  
MARKET ANALYSIS  
PROGRAM FOR 16K EX  
TRS-80 COLOR COMPUTER

TAPE - \$ 49.95  
DISK - \$ 69.95

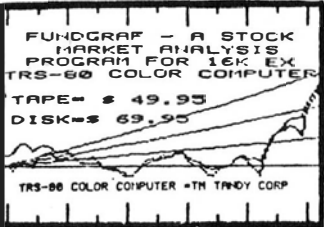

TRS-80 COLOR COMPUTER - TM TANDY CORP



# BASIC AID

**AT LAST!** Help for the BASIC programmer. **BASIC AID** is an indispensable addition to the Color Computer. It will save you valuable time and effort. If you write or modify BASIC programs, you need **BASIC AID**.

You get **43** Common BASIC commands available as single Control Key inputs. Greatly speeds up program entry.

A powerful feature is the ability to **redefine** any or all of the keys to your own specifications **PLUS** you get invaluable features such as a **MERGE** command, **Move Line** command and **Automatic Line Numbering**.

**MERGE**— Insert programs stored on cassette into your Basic program. You can even assign new line numbers to the program you read in. Great for creating your own tape library.

**MOVE**— Lets you move and renumber any part of your Basic program. GOTOs and GOSUBs are automatically changed.

**Redefine** any or all keys! Put in **your** most frequently used commands. Then save them to tape for use another time.



"An excellent program and fine utility." --  
— **RAINBOW** review,  
August, 1982, Page 27

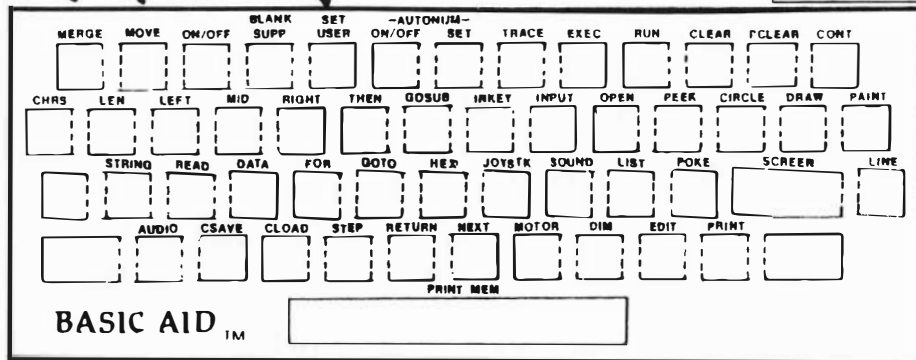

All of this in a convenient **ROM** cartridge which is available instantly on power-up. And, it uses almost none of your valuable memory! Comes with a convenient, easy to remove, **plastic** keyboard overlay.

**Disk Basic Aid \$49.95**

- \*Full Screen Edits
- \*Cross Reference
- \*Automatic Line Numbering
- \*Automatic Key Repeat
- \*2 Key Entry of Basic Keywords
- \*User Definable Keys
- \*Label Support



**BASIC AID CARTRIDGE**

**\$34.95**

Add \$2 Shipping and Handling

**SPECTRUM PROJECTS**

93-15 86th DRIVE  
WOODHAVEN, N.Y. 11421

(212) 441-2807 (VOICE)  
(212) 441-3755 (DATA)



**CHECK OUT OUR COLOR BBS' AT (212) 441-3755 & 441-3766**

# COLOR CABLES +



The must CoCo book for 1983. Contains a myriad of peeks and pokes, ROM and RAM upgrades, machine language backups, printer potpourri and more! Make your computer do things it never did before.  
.....\$14.95

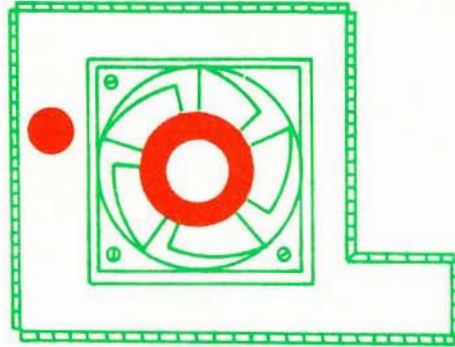

**COCO COOLER**—Internal cooling system. Prevent heat buildup inside your Color Computer. "CoCo Cooler keeps things cool."—Rainbow Review, Dec., 1982, Page 39 .....\$49.95

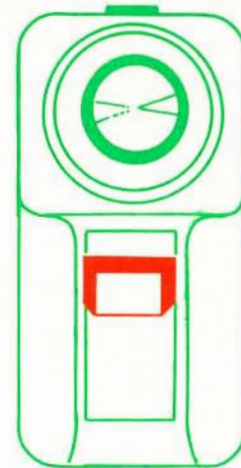

**THE SPECTRUM PADDLE**—Enjoy quicker response and higher game scores. Great for games with side-to-side action like Astro Blast, Space Invaders, Shooting Gallery and Clowns and Balloons. Includes "softtouch" fire button. "You have better control of the right to left movement than with any joystick we have seen so far"—Rainbow Review, Jan., 1983, Page 134.....\$19.95

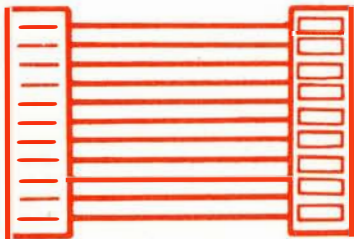

**DISK INTERFACE/ROM PACK EXTENDER — 3 FEET.** Move your disks and ROM packs where you want them. Gold plated contacts eliminate corrosion. ....\$29.95

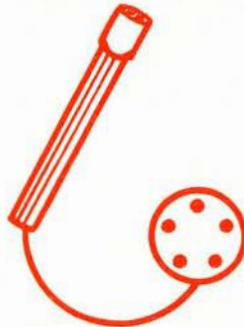

**LIGHT PEN**—Plugs right in to your joystick port and reads the colors off your screen. Includes four demo programs and is completely compatible with Computer Island's Fun-Pak software. ....\$19.95



**FOUR-PIN MALE TO FOUR PIN FEMALE — 15 FEET.** Move your printer or modem to another location—easier use...\$14.95

## MORE CABLES . . .

- Coaxial RF Adapter Cable and 8 Ft. RG59/u Coaxial Cable .....\$9.95\*
- Cassette Recorder Extension .....\$14.95
- SAM Saver (LED On/Off indicator)\$14.95
- Joystick Cable Extension .....\$14.95
- Disk Drive Extender .....\$14.95
- Serial Cable (specify printer) .....\$17.95
- Joystick "Y" Adapter .....\$19.95
- Two Drive Cable .....\$29.95
- Parallel Printer Cable .....\$34.95
- Four Drive Cable .....\$39.95
- Customized Cables.....CALL

\*Replaces gray audio cable to help reduce TV interference. Direct 75 ohm hookup.

Add \$2 for Shipping and Handling



**SPECTRUM PROJECTS**

93-15 86th DRIVE (212) 441-2807 (VOICE)  
WOODHAVEN, N.Y. 11421 (212) 441-3756 (DATA)

## COLOR COMPUTER EDITOR ASSEMBLER AND DEBUGGER

"CCEAD is a high quality program and excellent value. CCEAD is a tool that no assembly language programmer can afford to be without."—RAINBOW Review, February, 1983 \$6.95

## THE STRIPPER

Deletes REMarks, packs lines and removes blanks. "How much memory can you save? About 25% average."—RAINBOW Review, February, 1983 \$7.95

**\*Order both and save a buck.**

Call the Rainbow Connection At (212) 441-3755 & (212) 441-3766 for Rainbow Programs & Reviews

**DEALER/CLUB INQUIRIES WELCOME**

New York State Residents add appropriate taxes





Tired of plugging and unplugging devices from the RS232 port of your Color Computer? Make your life easier. Buy our RS232 expansion cable and connect two devices at the same time. Just right for printers, modems, etc. Anything that plugs into the Color Computer will plug into this high quality cable.

RS232 Cable \$20.00  
 RS 232 swither \$34.95  
 \*3 Position



COLORCOM/E BONUS! Order COLORCOM/E and get the RS232 cable for only \$15.00. Save \$5.00

32K RAM Button \$2.99  
 Nanos System Reference Card \$3.99

**SPECTRUM PUTS THE SLAM ON RAM**

16K Chips \$12.00/set  
 64K Chips \$49.95/set  
 Basic ROM 1.1 \$36.00  
 Disk ROM \$39.95  
 6883 (SAM) Chip with heat sink \$29.95  
 6809E \$29.95  
 CoCo First Aid Kit (Be Prepared) (2 6821's, 6809E, & 6883) \$69.95

Color Computer Tech Manual \$7.95  
 Epson Printer Interface (Serial I/O Port) \$49.95  
 Lowercase Kit **ONLY** \$69.95  
 12 Key Numeric Keypad \$79.95  
 Extended Basic ROM Kit \$88.00  
 64K "E"/"F"/TDP Board Upgrade \$99.95\*  
 Color-80BBS Package (Silican Rainbow) \$115.00\*\*  
 RS Disk Interface (with manual) \$179.95  
 Epson MX-80 w/CoCo Interface \$499.95

\* FREE Return UPS Shipping  
 \*\*Requires 64K Ext. Basic w/2 Prives

Now give your CoCo a compact drawing board for direct sketching. The Spectrum Sketchpad \$79.95



# COLORCOM / E

## SMART TERMINAL PACKAGE

WE DIDN'T WAIT for the competition to catch up with us! We've added even MORE features to COLORCOM/E, our superb Smart Terminal program for the Color Computer. Compare before you buy. NOBODY offers you more!

- ★ Complete Upload and Download Support
- ★ Online Cassette/Disk Reads and Writes
- ★ 110, 300, 600, or 1200 Baud
- ★ Full or Half Duplex
- ★ Preenter Data Before Calling (Saves \$\$'s)
- ★ Offline and Online Scrolling
- ★ Automatic Capture of Files
- ★ Send All 127 ASCII Characters From Keyboard
- ★ Word Mode Eliminates split Words
- ★ 7 or 8 Data Bits (Including Graphics Support)
- ★ Efficient Data Storage S-t-r-e-t-c-h-e-s Memory
- ★ ROM Pack or Disk

**COLORCOM/E \$49.95**

AND, our efficient storage and easy editing of received data makes printing to your printer offline a snap. Select any portion of the received data for printing. No need to print everything.



Add \$2 for Shipping and Handling

**64K DISK UTILITY PACKAGE**

1. **40K**—Tired of seeing 228237A? MEM now returns 31015 with four pages for graphics!
2. **Software Print Spooler**—Tired of waiting for your printer? You can now output data to a RAM buffer at high speed and go back to programming while your data is being printed simultaneously on your printer! Works



**SPECTRUM PROJECTS**

93-15 88th DRIVE (212) 441-2807 (VOICE)  
 WOODHAVEN, N.Y. 11421 (212) 441-3756 (DATA)

with printers that accept 1200 baud.  
 3. **ROMCRACK**—Now you can place your ROM PAC software on disk! ROMCRACK can make most ROM PAC software work on your disk. \$21.95  
 ... Available on cassette tape by itself for \$9.95. Half-price when ordered with Spectrum's 64K chips!

Call the Rainbow Connection At (212) 441-3755 & (212) 441-3766 for Rainbow Programs & Reviews

**DEALER/CLUB INQUIRIES WELCOME**  
 New York State Residents add appropriate taxes



## Synther-7 Creates A Symphony for CoCo

When was the last time you had a chance to play a Hogfife or a Krumphorn? Have you ever gone to a late-night jam session, only to realize you left your Jninni at home? Well, thanks to Computerware's *Synther-7* program, you'll have these instruments, and more, right on the keyboard of your Color Computer.

*Synther-7* is a real-time musical synthesizer which is totally controlled by software. It enables you to generate musical notes and sound effects from designated keys on the computer. These sounds can be modified by several parameters before they wind up on your TV's audio speaker or cassette's audio input. Because the sound is routed to the AUX jack, it enables you to record your works right onto the cassette recorder, or for that matter, any recording device at all.

The machine language cassette version loads and automatically executes from tape with one *CLOADM* command. It comes with six pages of easy-to-understand documentation, the last page being a summary of all the commands. It was only a matter of a few minutes before I was creating masterpieces on my new "instrument."

Upon loading, the top of the screen will show a picture of a piano keyboard (two octaves worth) and the corresponding keys on the computer which activate them. The "QWERTY" row, including the up-arrow key all the way to the *CLEAR* key, represent the white keys of the piano. The number row, from "1" to the *BREAK* key, corresponds to the black keys (sharps and flats) of the piano. While this takes some getting used to, Computerware suggests marking the keys which sound notes with cellophane tape. A keyboard overlay of some sort might have been nice, but it wouldn't be difficult at all to make one. I plan to do so, using the overlay from Radio Shack's *Art Gallery* program as a template.

Also pictured on the screen are a block of text labeled STOPS (the different preset sounds), a bar graph on the lower left which indicates the envelope of the sound, a block

of text identifying different control keys, and a bar indicator of the current pitch range. As these choices imply, there are lots of ways to change the nature of sound, and the features of this program far exceed those of the regular *SOUND* and *PLAY* commands.

Rather than try to describe the sounds of the five presets, suffice to say they range from somewhat natural (Lute) to borderline bizarre (Krumphorn). Synthesists will be happy to know that you have full control of ADSR (attack, decay, sustain and release). Changing the values of these functions is achieved by hitting the appropriate keys (which conveniently occupy the third row of the keyboard). Furthermore, you can change the vibrato and volume, and even add twang and bend to a note. Try doing that when you start with Krumphorn as your basic sound! It's music from another planet!

Learning to use *Synther-7* is easy because the documentation takes you through an example of sound creation. I'm partial to documentation that serves somewhat as a tutorial because it cuts down on the time it takes to master different functions. With most computer programs, it's a matter of learning what keys do what, and learning by example is the best way.

After creating several different sounds (I even wrote a nice melody), I experimented with sound effects. It was relatively simple to create the sound of an ambulance siren (coming after *who*, I wondered). Then I wanted to see how long I could sustain one note. *Forever* seemed to be the top limit.

As a recording engineer and musician, I've been somewhat skeptical of the synthesizer capabilities of the 80C. This software program is well thought out, and can provide many hours of composition and experimentation with sound. "Ah, yes," you say, "but *how good* it is? Could it be used in a real recording situation, or is it more or less a toy?"

I first wanted to test the S/N (signal-to-noise) ratio of the sound output. Although I didn't have any real test equipment at home, I decided to record onto the cassette, simply to see what it sounded like. Playback seemed to contain some low-end rumble around 50 or 60 hz. But to be fair, I checked further to see whether it was the program or the tape recorder that was at fault. Using a "Y" adaptor (available at any Radio Shack store), I routed the sound output to my Technics tape deck. The playback was astonishingly clean-sounding over the whole frequency range, but I was further surprised by the decent reproduction of low-end sounds.

"What about the pitch?" you argue. I knew from the past that the *SOUND* and *PLAY* commands on the CoCo were not true-to-pitch. I checked *Synther-7*'s notes against those on my Casio. Before you even suspect the accuracy of the Casio, keep in mind that it was tuned by a professional piano tuner with high tech tuning equipment. I checked one against the other, and it was right on! (How did they do that?)

Overall, this is an excellent program, well-worth the list price. If there were one feature missing, it would be a save-to-tape for any sound creations you might want to have later. They suggest that you write these numbers down for future use, but I'm lazy, and besides, that's why I got a computer in the first place. But enough said, I'm going to lay down different tracks on my Teac Portastudio, another marvel of technology. I must not forget my Gamba.

(Computerware, Box 668, Encinitas, CA 92024, \$21.95 on tape, \$26.96 on disk)

—Bob Safir

Now a LOGO for the  
COLOR COMPUTER

\*\*\*TINY TURTLE\*\*\*

TINY TURTLE is an affordable, fully compatible LOGO language with high resolution turtle graphics, music, fast processor operation, and storing and retrieval of user procedures. TINY TURTLE comes complete with soft-copy reference user manual.

32K/EXTD BASIC/CASSETTE	\$39.95
HARD-COPY MANUAL	\$4.95
SDS COMPUTERS	BOGOTA, N.J.
POB 450	07603
N.J. ADD 5% TAX	



"Recommend to anyone who enjoys games on his CoCo." RAINBOW Review, March 1983

# THE DOUBLE JOYSTICK INTERFACE\*



Now you can hookup two Atari\* type joysticks to your Color Computer or TDP System-100 for only \$19.95

\$39.95 - The Interface with two Atari\* joysticks

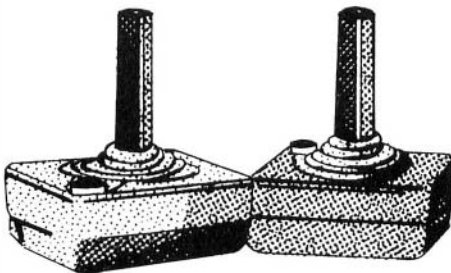

\* Interface made by WICO. Atari is a registered trademark of Atari, Inc.

**YES!** PLEASE SEND:  
 INTERFACES... \$19.95  
 STICK/INTERFACE SETS... \$39.95  
all orders plus \$2 shipping

NAME \_\_\_\_\_  
ADDRESS \_\_\_\_\_  
CITY, STATE, ZIP \_\_\_\_\_

N.Y. residents add sales tax

**SPECTRUM PROJECTS**

93-15 86th DRIVE  
WOODHAVEN, NY 11421  
212-441-2807

# PIPELINE

**SOMETHING NEW IS** just out from Radio Shack and, while it is not *strictly* for the CoCo, we think it is something you'll be interested in. It is called the TRD-80 Model 100 Portable Computer. This is a *true* portable computer with built-in functions such as an address file, a word processor and modem for communications. It even has a telephone dialer!

Most interesting of all, the Portable Computer connects easily to any of the other Radio Shack models—including, of course, our own CoCo. You can write letters and memos on a plane or while riding (but not driving) in a car and transfer files to CoCo as soon as you get back. Or, you can just call up your CoCo and dump information on the phone.

The Portable Computer comes with 8K, 16K, 24K and 32K. Starts at \$799. The display is eight lines by 40 characters on an LCD screen. Go see it.

As you know, Radio Shack has introduced a number of new computers since CoCo. And, while we think the machines are good, none of them have had the personal appeal of CoCo. Until now. We're really enthusiastic about this new machine. In fact, we plan a new publication for it — *Portable Computing Magazine*. The first issue is due in July and there is a charter subscription rate of \$23 until July 1. If you're interested, let us know.

**WE FEEL IT IMPORTANT** to call your attention to the latest issue of *TRS-80 Microcomputer News* and the comments made by Jon Shirley, vice president for computer merchandising for Tandy. Mr. Shirley talks about how some manufacturers "rate" the RAM available in their machines. Since you, as a loyal CoCo owner, might be questioned about this issue, we thought you might be interested in what Mr. Shirley has to say.

And, while he does not mention the Commodore 64, we will. Simply because we were at a friend's house the other day, and he showed us his new Commodore. "It has 64K," he said proudly. We PRINTed MEM, and showed him otherwise. Yes, it has 64K of RAM—just like CoCo does—but, of course, only some 32K is usable.

Clearly, we feel Radio Shack's policy of properly characterizing CoCo as a

32K machine is a more accurate description of its capabilities. And, of course, you know you can access all 64K of CoCo RAM.

\*\*\*\*\*

**ARMADILLOS MOVE SLOWLY**, but they do move. And, so, for Armadillo Software, which has a new address and a new telephone number. You can reach them at (512) 835-1088.

\*\*\*\*\*

**IN THE "WE GOOFED"** area is this footnote to the review of the light pen software for the Spectrum light pen available from Computer Island. The package of software *and hardware is available only from Computer Island. Spectrum Projects does not carry the software—but does have the light pen, of course.*

\*\*\*\*\*

**HERE'S A BULLETIN:** There are several new bulletin boards now in operation, devoted primarily to CoCo. Among them are:

One out of Tom Mix Software at (616) 364-4791. By the way, Tom Mix' *Donkey King* program has a new name. Its now known as *The King*.

If you want some southern flavor to your communications, try *Kaleidoscope*, a 24-hour BBS out of the middle Georgia area. Willie Bethay is SYSOP and you can connect up at (912) 923-4679.

Three bulletin boards at one place? Yes, that's what SYSOP Bob Rosen announces. He's added a third to the present Rainbow Connection. Call either (212) 441-3755, (212) 441-3766 or (212) 441-5719 24-hours a day, seven days a week.

Queens must be the bulletin board capital of the entire northern hemisphere. In addition to Bob's three, there is a new one based in that New York City borough called *CoCo's Nest*. It is open 24 hours a day and Arnold Schiffman is the SYSOP. Its run by Strictly Communications, Inc.

\*\*\*\*\*

**IF YOU HAVE A** cassette copy of *Spectaculator*, we understand that you can get it converted to disk. We've just heard this and have not had an opportunity to check it out, but we hear that Tandy will do it for you if you send the original tape to Fort Worth and ask.

\*\*\*\*\*

**YOU MIGHT WANT TO CHECK** the continuous checks which a firm called Synergetic Systems has developed. There is a program to go with it and we are told the package of program and checks can be purchased as a package for \$59.95. The firm's address is 4715 Shepard Road, Mulberry, FL 33860. Phone is (813) 646-6557.

\*\*\*\*\*

**GIMIX, WHICH IS A** leader in 6809 products, has a new 6809 CPU Board and software package available. The new board is specifically intended for use with multi-user multi-tasking operating systems. The software, OS-9 GMX III, is an enhanced version of the OS-9 operating system which was written to take full advantage of the new CPU Board. Information is available from Gimix, Inc., 1337 W. 37th Place, Chicago, IL 60609, (312) 927-5510.

\*\*\*\*\*

**EDUCATORS WILL BE** interested to know that Radio Shack has announced a program called "America's Educational Challenge" for all elementary and secondary school teachers in the United States. The purpose of the program is to assist teachers to achieve basic familiarity with computers and their use in the classroom. Information on the program will be mailed this month to the principal of every school in the United States. Also included are free certificates for free classes in BASIC at Radio Shack's Computer Centers.

\*\*\*\*\*

**A NEW LINE OF** modems and "Speed Select" Modem I/O cards has been announced by Universal Data Research. The new modems are designed to connect any terminal or computer with telephone lines. More information is available from Universal Data Research, 2457 Wehrle Drive, Buffalo, NY 14221 (716) 631-3011.



**Spectrum Projects**  
**Your TDP-100 Dealer**  
**Trims Down Prices!**

**64K TDP-100**  
**with Ext/Basic**  
\$499.95

**Line Printer I**  
**(DMP-100)**  
\$299.95

**Color Drive**  
**Zero**  
\$449.95

**DC Modem I**  
**Communications**  
\$129.95

**Color Cassette**  
**Recorder (CCR 81)**  
\$49.95

**16K TDP-100**  
**with Ext/Basic**  
\$399.95

**CALL 212-441-2807**  
all orders plus \$2.00 S/H  
NY. residents add sales tax

**SPECTRUM PROJECTS**  
93-15 86th DRIVE  
WOODHAVEN, NY 11421

## Humor, Good Graphics Make *Crystal Revenge* Sparkle

*Crystal Revenge* is a fine game by Tom Roginski. The premise is that you (former galactic imperialists from the Crystal World) have been driven back to your homeworld, where you are under attack by various races whom you had sought to bring under your "enlightened rule." You are a space sector defender, and must laser out attackers' ships, protecting cities and your supply dump.

The graphics are excellent. An arc of the planet, its several large cities marked on its surface, is at the right of the screen. You maneuver a laser firing ring, a sparkly affair controlled by the right joystick. You must lock on to the moving target before firing. Attacker ships advance one by one across the black of space from the left. A fuel bar across the top of the screen shows how much laser fuel remains.

Hits on your planet show on the homeworld and are recorded at the bottom right of the screen; attacker ships downed are recorded at the bottom left. There is a complicated point scoring system, providing different levels of points for ships hit from succeeding waves, as well as bonuses for conserving laser fuel, minimizing hits on your planet, saving cities, your supply base, and the homeworld itself. Point-scores are calculated and displayed after each game, and compared to previous high scores.

You play for a defined win, as determined by two menu-selected difficulty parameters. You can enter a previous high score at the beginning, or play against high score made in a particular series of games, so that although only one person can play at a time, a number of players can compete on scores.

The colors are excellent. Roginski has devised a method

of controlling 4 colors in PMODE 4 which involves displaying two ships just before a game and asking you to indicate if the one on top is red or not. Your answer fixes the false colors throughout a game without use of RESET lines. Roginski says that "as a by-product of the way the false colors are set" red areas of blue ships (or blue areas of red ones) are "armored," and hits by laser ring locked onto these areas will not knock out the ship. Roginski is writing an article about his use and control of false colors in hi-res. I look forward to seeing it after this interesting tidbit. Though the "armor" may be making the best of a necessary consequence of the programming method, it provides one of the most frustrating—and fascinating—features of the game. You lock onto an advancing ship. You got it! You fire! Nothing happens, you hit an armored section! Tally Ho, to the chase again.

The ships themselves add a certain funkiness to the game. The first wave comes at you one at a time, straight across, a bit herky-jerky (emphasized by the sounds they make), but not really evasive. They are rather baroque, but definitely spaceships—fish-like shapes with armored dorsal and ventral turrets. Not so the succeeding waves. I can only describe those as "critter-like." They come at you hopping, bopping, twitching, hula-shimmying; to say their trajectories are unpredictable is an understatement. They don't have trajectories; they do war dances. Too, as they approach and skitter or scoot away from your firing ring, they sneer, jeer, flee and Bronx cheer at you. When you get one, it shudders, heaves, changes colors, and disintegrates, singing a little deathsong of pathetic defiance (veh-ree organic).

You have to destroy 10 ships in an incoming wave, and from three to five waves to save your homeworld. This is quite hard to do, though Roginski has designed the game to be winnable at all levels. However, if your supply base is destroyed, your laser will not be refueled for the next wave, and you will confront those funky little dip-ships impotently, with a firing ring that will lock on but do no damage. You have only 30 shots per wave, so refueling is essential.

You can cheat a bit in this game. I always look for ways to do that, since it expresses my rebellion against arcade-style games. You can pause the action with "shift@" and get your joystick under control for moving rapidly into best intercept position.

When the planet-destroying number of hits has occurred, concentric circles of throbbing red radiation spread from the last hit zone to fill all of space. *Ciao*, Crystal World. Such is the fate of would-be enlightened rulers.

To fit the entire program into 16K, Roginski has made it in three modules. The first, with complete instructions and well-done title screens (which use semigraphics-24 mode f or some novel effects), is auto-overlaid by the data and game modules. Later, when you want to skip instructions and get right onto those fleeing critter-ships, you can bypass that module and *CLOADM* "DATA" and "REVENGE."

A Sugar Software auto-run machine language program governs loads. (Sugar licenses its purchasers to use it in their own commercial programs. Good deal.) I loved the owl logo—you can see it in the Owl-Ware ad in this issue. It's a nicely done sketch, smoothly replicating all those curves. The owl hoots like a demented canary during loading.

This program is well worth having, even if you're not fond of arcade games, both because of the element of humor and because of the graphics effects.

(Owl-Ware, P.O. Box 116, Martztown, PA 19539, \$16.95)

—Detective Fuzzy

★ COLONIAL TRILOGY ★



THREE INCREDIBLE NEW GAMES  
FOR THE COLOR COMPUTER

**HI-RES — 32K — EXT BASIC**

**COLONIAL WARS:** TWO PLAYER GAME ON A GALACTIC SCALE WITH HYCOMP'S UNIQUE SPLIT SCREEN CONCEPT—IT'S ALMOST LIKE HAVING A SEPARATE MONITOR FOR EACH PLAYER! COLONIZE AND BATTLE FOR CONTROL OF AN 11 STAR SYSTEM WHILE COMMANDING MASSIVE BATTLECARRIERS, FIGHTER SQUADRONS, FREIGHTERS, AND PLANETARY DEFENSE. WITH GAME SAVE (3-8hrs)

**ZYRON:** TWO PLAYERS BATTLE WITHIN AN ASTEROID FIELD WITH SHIPS BUILT TO THEIR OWN SPECIFICATIONS. TWO SCENARIOS INCLUDED—ONE PLAYER TRIES TO SLIP FREIGHTERS PAST THE OTHER'S DEFENSES OR AN ALL OUT BATTLE. (2-4hrs)

**QUESTAR:** EXPLORE OVER 30 PLANETS AND ENCOUNTER UNKNOWN CIVILIZATIONS, DESERTED CITIES, AND BUSY STARPORTS WHILE SEARCHING FOR HIDDEN ZYRON BASES. AN EXCELLENT ONE PLAYER GRAPHICS ADVENTURE GAME. (60-90min)

---

ONLY \$19.95 EACH OR ALL THREE FOR \$49.95!  
PLUS \$1.50 FOR SHIPPING

---

AVAILABLE ONLY FROM

CHECK OR MONEY  
ORDER ONLY.  
SEND SASE FOR  
MORE INFORMATION.

**\*HYCOMP\***

P.O. BOX 15331  
TULSA, OK 74158  
(918)266-6452

# LOSING BATTLES WITH A GLOOMSTICK?

"The feeling of this joystick is superb"  
— 80 Micro March 1983

PUT THE JOY BACK IN  
COLOR COMPUTING  
WITH A NEW.....

## SPECTRUM STICK

Dealer/Club Inquiries Invited

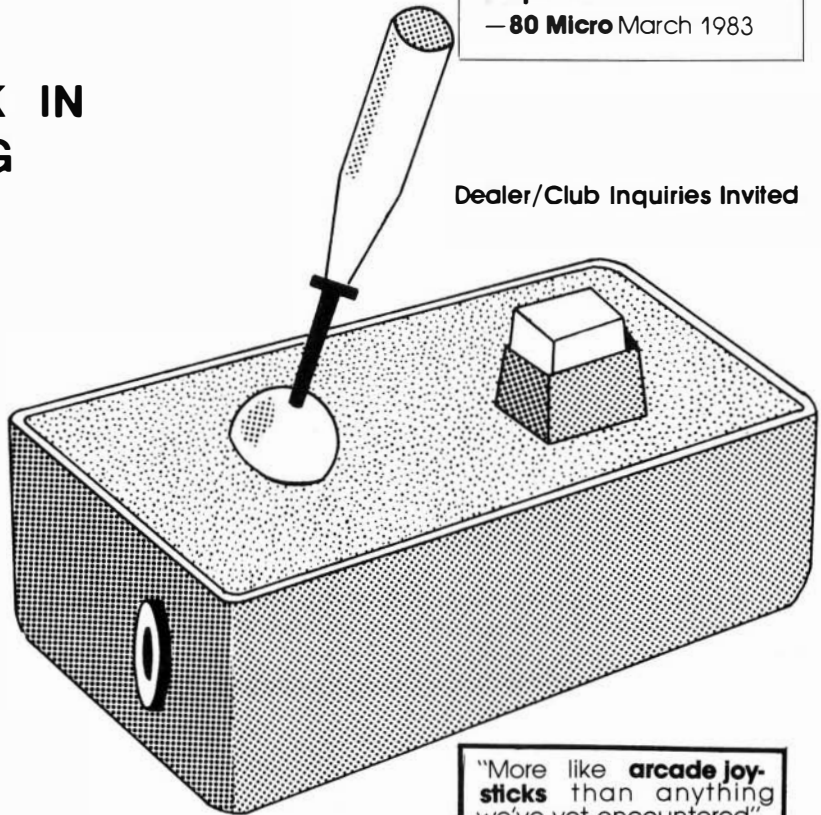

Features include:

- Power on/off LED indicator
- Ball joint components for a true feel of control
- Extra long cables
- Sturdy construction
- Hair trigger response

"More like arcade joysticks than anything we've yet encountered"  
Rainbow review October 1982, Page 112

"Both the joystick and pushbutton should have a considerably longer life than the Radio Shack unit since they are made of higher quality components"—  
Creative Computing Feb., 1983, Issue.

please send( ) SPECTRUM STICK(s) at  
\$39.95 each plus \$2.00 shipping to

name \_\_\_\_\_

address \_\_\_\_\_

city,state,zip \_\_\_\_\_

N.Y. Residents Add Appropriate Taxes

SPECTRUM PROJECTS

93-15 86th DRIVE

WOODHAVEN, N.Y. 11421





## A Colorful Game Of Draw —That's *Color Poker*

By Joseph Kohn



*Color Poker* duplicates the electronic draw poker games prevalent in Vegas, and requires 16K, Extended BASIC. Playing is quite simple. The machine deals you five cards. You have the option of keeping all of them or discarding up to four to improve your hand. How much you win, if you are lucky, is based on the built-in odds for each winning hand. I use the same odds as Las Vegas, except that I don't require that a valid pair be jacks or better. I don't like losing that much! If you want to be more daring, I've included the program changes.

The Color Computer is ideal for providing the card graphics and colors that make the game visually interesting. The speed of the Extended Color BASIC in implementing the graphic commands keeps play at a brisk pace.

The program is composed of four main parts: graphics routines (lines 80-870), the actual play of deal and discard (lines 880-1320), determining the value of your hand (lines 1330-1620) and the final tally of your finances (lines 1630-1710).

The bulk of the graphics routines are the *DRAW* strings in lines 90-650. These, along with the *DRAW* subroutine in line 670, provide the alphanumeric displays that both prompt the player and provide all the necessary information for playing.

These strings are a subset of a very useful library program which I call Font. This consists of the *DRAW* strings for all the ASCII characters and provides a source of alphanumeric characters for a great many of my high resolution programs. By changing scale factors, start positions and colors, many interesting effects can be created. The title screen utilizes a scale of S16, each word is drawn with green, then offset and redrawn with blue.

After displaying the odds for each winning combination, play starts by selecting the bet in line 900. I have generally

found that most games requiring you to choose a bet quickly become boring. Therefore I decided to make the betting random, which introduces more chance and interest. Here the variable BT is set from \$100 to \$1000 in \$100 steps. The bet changes to thousands after you have more than \$20,000. This is accomplished by using the logical statement  $TT > 20000$ , where TT is your total bankroll. The INT function is required because of the inaccuracies of the exponential operator, which could produce undesirable digits to the fourth decimal place.

Each deal is from a fresh deck, set in line 930. Five cards are dealt at random and the cards are drawn on the screen. The card shape uses the *LINE* command with a filled box. The card values are drawn using the *DRAW* strings, then the appropriate symbol is placed on the card face using PUT.

The player enters the numbers of the cards he wishes to discard. The discards are indicated by boxes around the selected cards. If a mistake is made, the player can cancel his entries and start over.

After being dealt replacement cards, scoring of the hand proceeds. This starts with sorting the cards by face value. Tests are made for all possible winning combinations starting with straights, then flushes and finally ending with a single pair.

If the cards do not produce a winning hand, the bet is subtracted from the player's bankroll. Winning hands are paid off according to the odds stored in the corresponding *DATA* statements, line 850.

As I indicated, if you wish to define a valid pair as jacks or better, do the following: Extend line 1580 with  $:Y=CV(CD(X))$ . And add line 1605 as follows: 1605 IF  $Y < 11$  AND  $Y > 1$  THEN 1620.

Good luck!

# COLORSOFT™

## ESCAPE

*A 3-D GRAPHICS ADVENTURE WITH SOUND  
(Machine Language for Fast Action)*

This is NOT the usual "find the treasure" adventure. In **ESCAPE**, you are trapped on the top floor of a skyscraper and the only way out is by using a very unusual elevator. You must give the elevator the correct code or else the ride down is a real killer. The maze-like halls seem to come to life due to the fantastic 3-D graphics. Search the halls for rooms which contain clues to the correct code. Clues must be deciphered to learn the elevator's secret code. Game times depends on the skill of the player, but it is typically 8-10 hours. **ESCAPE** is suitable for group play. A mentally stimulating experience.

16K BASIC

\$18.95

## RECIPE FILE

*A CASSETTE BASED STORAGE AND  
RETRIEVAL SYSTEM*

This program permits storage of your favorite recipes for retrieval by your computer. Once a recipe has been recalled, then the computer can adjust the ingredient measure for serving the desired number of persons. Each recipe can contain special comments on preparation as well as the full instructions for using the recipe. Included is a line oriented text editor for creating and editing the variable length files. Completely menu driven and very user friendly. Easily modified by the user for use in keeping track of record, coin or stamp collections or whatever your interest. Screen or printer output.

16K Ext. BASIC

\$21.95

**SPECIAL:** A collection of 30 recipes covering main meals to snacks. Only \$3.95 with program.

## SQUIRE

**SQUIRE** is a challenging game of asset management. The player must manage a country estate and contend with crop failure, investment losses, taxes and other such headaches. The object of the game is to increase the estate's value while providing for the peasant workers. The starting assets are computer selected so that each game offers different challenges. Great experience for the kids or aspiring executives.

16K Ext. BASIC

\$14.95

## HOUSEHOLD EXPENSE MANAGER

This menu driven program package is designed for creating and maintaining a data file on cassette of 30 household expense categories for a 12-month period. It also keeps cumulative totals and a separate total of tax deductible expenses. A comparative analysis program provides a graphic presentation of relative expenses between any two months during the year. The user can change categories by modifying program code. Screen or printer output.

16K Ext. BASIC

\$19.95

## FLIPPER

A fun and challenging version of the Othello™ type board games. This version includes options for play solely by the computer, one player against the computer, or two players against each other. The computer can play on four skill levels. Very colorful with plenty of sound. Fun for kids and challenging for adults. Great for parties.

16K Ext. BASIC

\$16.95

**COLOR  
SOFT WARE**

**SERVICES**

P.O. BOX 1708, DEPT. R  
GREENVILLE, TEXAS 75401

INCLUDE \$2.25 HANDLING PER ORDER  
WRITE FOR FREE CATALOG

DEALER INQUIRES INVITED



TELEPHONE ORDERS  
(214) 454-3674  
9-4 Monday-Saturday

VISA/MASTERCARD

Table 1. List of Key Variables

- CS—Card suit
- CV—Card value
- CD—Cards dealt
- BT—Player bet
- TT—Player bankroll
- OD—Odds for winning hand
- DC—Discards

A cassette copy of *Color Poker* is available from the author for \$5. Send to: Joseph Kohn, 1343 Blossom Avenue, Redlands, CA 92373.

400	0543
730	0AAB
1000	0FF8
1400	153B
END	1A07

The listing:

```

10 GOTO300000
20 '
30 'COLOR POKER
40 'JOSEPH KOHN
50 '1343 BLOSSOM AVE
60 'REDLANDS, CA 92373
70 CLS: DIM A$(89): X=RND(-TIMER)
80 '---DRAW STRINGS
90 A$(33)="U4E2F2D2NL4D2BR3" 'A
100 A$(35)="BR3E1BU4H1L2G1D4F1R2
BR4" 'C
110 A$(36)="U6R3F1D4G1L3BR7" 'D
120 A$(37)="R4BU6L4D3NR2D3BR7" '
E
130 A$(38)="U6NR4D3NR2D3BR7" 'F
140 A$(39)="BR4BU5H1L2G1D4F1R3U2
NL1D2BR3" 'G
150 A$(40)="U6D3R4U3D6BR3" 'H
160 A$(41)="BU6BR1R2L1D6L1R2BR4"
'I
170 A$(42)="BU1F1R2E1U5BD6BR3"
'J
180 A$(43)="U6D3R1NE3F3BR3" 'K
190 A$(44)="NU6R4BR3" 'L
200 A$(45)="U6F2ND1E2D6BR3" 'M
210 A$(46)="U6F4U4D6BR3" 'N
220 A$(47)="BU1U4E1R2F1D4G1L2NH1
BR6" 'O
230 A$(48)="U6R3F1D1G1L3BF3BR4"
'P
240 A$(49)="BU1U4E1R2F1D3G1NH1NF
1G1L1NH1BR6" 'Q
250 A$(50)="U6R3F1D1G1L3R1F3BR3"
'R
260 A$(51)="R3E1U1H1L2H1U1E1R3BD
6BR3" 'S
270 A$(52)="BU6R4L2D6BR5" 'T
280 A$(53)="BU1U5BR4D5G1L2NH1BR6
" 'U
290 A$(54)="BU4NU2F1D1F1ND1E1U1E
1U2BD6BR3" 'V
300 A$(55)="NU6E2F2NU6BR3" 'W
310 A$(57)="BU6D1F2E2U1D1G2D3BR5

```

```

" 'Y
320 A$(65)="BU4R2F1D1L2G1F1R2NU2
R1BR3" 'a
330 A$(66)="U6D2R3F1D2G1L3BR7" '
b
340 A$(67)="BU4BR2NF1L2G1D2F1R2N
E1BR4" 'c
350 A$(68)="BU4BR4L3G1D2F1R3NU6B
R3" 'd
360 A$(69)="BR3L2H1U2E1R2F1D1NL4
BD2BR3" 'e
370 A$(72)="U6D3E1R2F1D3BR3" 'h
380 A$(73)="BU6BR1R1BD2NL1D4L1R2
BR4" 'i
390 A$(79)="BU1U2E1R2F1D2G1L2NH1
BR7" 'o
400 A$(82)="U4D1E1R2F1BD3BR3" 'r
410 A$(83)="R3E1H1L2H1E1R3BD4BR3
" 's
420 A$(84)="BU5R4L2U1D5F1E1BD1BR
3" 't
430 A$(85)="BU4D3F1R2NU4R1BR3" '
u
440 A$(86)="BU4F1D1F1ND1E1U1E1BD
4BR3" 'v
450 A$(87)="BU4D3F1E1NU2F1E1U3BD
4BR3" 'w
460 A$(89)="BU4D3F1R3U4D5G1L3BU2
BR7" 'y
470 A$(0)="BR3" 'SPACE
480 A$(1)="BR1R1BU2U4BD6BR5" '!
490 A$(4)="BR2U6D1R2L3G1F1R2F1G1
L3BD1BR7" '$
500 A$(12)="U1R1D1NL1D1G1BU2BR7"
'COMMA
510 A$(13)="BU3R4BD3BR3" '-
520 A$(16)="BU1U4E1R1F1D4G1L1NH1
BR6" '0
530 A$(17)="BU6BR2NG1D6L1R2BR4"
'1
540 A$(18)="BU5E1R2F1D1G1L2G1D2R
4BR3" '2
550 A$(19)="BU5E1R2F1D1G1NL1F1D1
G1L2NH1BR6" '3
560 A$(20)="BU2U1E3D4NR1NL3D2BR4
" '4
570 A$(21)="BU1F1R2E1U2H1L3U2R4B
D6BR3" '5
580 A$(22)="BU6BR3L1G2D3F1R2E1U1
H1L3BD3BR7" '6
590 A$(23)="BU6R4D1G4D1BR7" '7
600 A$(24)="BU1U1E1R2E1U1H1L2G1D
1F1R2F1D1G1L2NH1BR6" '8
610 A$(25)="BR1R1E2U3H1L2G1D1F1R
3BD3BR3" '9
620 A$(26)="BU6NG1D6L1R2BR2BU1U4
E1F1D4G1NH1" '10
630 A$(27)="U1R1D1L1BU3U1R1D1L1B
D5E1U1BR6" 'j
640 A$(29)="BU2NR4BU2R4BD4BR3" '

```





# INTERNATIONAL SOFTWARE INC.

(604) 474 2271

771 HOCKLEY AVE, VICTORIA, B.C. V9B 2V5

TOP STIX, IS A JOYSTICK INTERFACE FOR THE COLOR COMPUTER, IT WILL ALLOW YOU TO USE THE FAMOUS ATARI JOYSTICK AND EVEN DATASOFT'S LESTICK, THE TOP STIX WORKS ON MOST PROGRAMS BUT NOT ALL, GET THE FEEL OF ARCADE FUN ORDER YOURS NOW \$29.95

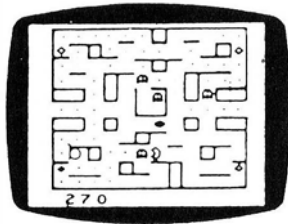

**GHOST GOBLER**

\$27.95

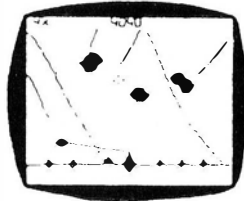

**DEFENSE**

\$27.95

TO ORDER SEND CHEQUE OR MONEY ORDER, VISA NO#, AND EXP DATE TO ADDRESS ABOVE, PLEASE ALLOW 2 TO 3 WEEKS FOR DELIVERY.

CATALOGUE WITH EVERY ORDER

**PLANET INVASION**

\$27.95

**CCTHELLO**

\$22.95

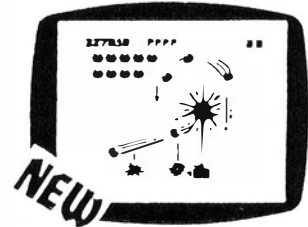

**GALAX ATTAX**

\$27.95

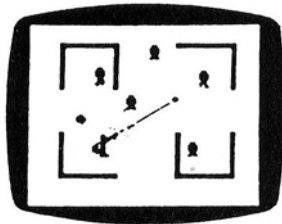

**ROBOT BATTLE**

\$27.95

**SPACE RACE**

\$27.95

**PIRATES AHOY**

\$11.95

**ESCAPE FROM PRISON CITY**

\$10.95

Please allow 2-3 weeks for delivery

NO C.O.D. ORDERS

- COUPON -

MAIL ORDER ONLY PLEASE

**20% OFF**

**any order over \$30.00**

*Include this coupon with your order to get this special offer.*

- COUPON -



CANADIANS ORDER IN CANADA AND SAVE. MAIL ORDER OR VISIT THE DEALER NEAREST YOU, ALL PRICES IN CANADIAN FUNDS

DEALERS ON VANCOUVER ISLAND:

IN SIDNEY: SIDNEY RADIO SHACK LTD.

IN LADYSMITH: LADYSMITH RADIO SHACK LTD.

IN CAMPBELL RIVER: CAMPBELL RIVER RADIO SHACK LTD.

IN VICTORIA: EXCALIBUR SYSTEMS LTD.

IN PARKSVILLE: PARKSVILLE RADIO SHACK LTD.

IN PORT HARDY: PORT HARDY RADIO SHACK LTD.

IN SOOKE: SOOKE RADIO SHACK LTD.

IN COURTENAY: COURTENAY RADIO SHACK.

# HELP WANTED

Dragon Slayers, Space Pilots, Witch Doctors, Maze Makers, Professors and other creative programmers.

## We Want You!

Your original Color Computer Software program is worth money and we want to discuss it with you...

## Earn Top Buck!



24001 ALICIA PKWY., NO. 226  
MISSION VIEJO, CA 92691  
(714) 768-1551

## COMPUTERS

Growing Company with lots of

P  
Po  
exp  
Req  
assi  
knc

13  
Co

M  
Wit  
Illu  
com  
doll  
mac  
Con  
poss  
exp  
is  
th

```
650 A$(31)="BR1R1BU2E2U1H1L2G1BD
5BR7" '?'
660 GOTO680
670 FORX1=1TO LEN(X$):Y1=ASC(MID
$(X$,X1,1))-32:DRAW"X$(Y1)";:NE
XT:RETURN
680 PMODE1,1:PCLS2:DRAW"BM36,52;
S16C1":X$="COLOR":GOSUB670:DRAW"
BM40,52;C3":GOSUB670:DRAW"BM72,1
12;C1":X$="POKER":GOSUB670:DRAW"
BM76,112;C3":GOSUB670
690 '---CREATE DECK
700 Z=0:DIMCS(52),CV(52),DD(52),
C(12),H(12),S(12),D(12)
710 FORX=1TO4 '1=CLUB,2=SPADE,3=
HEART,4=DIAMOND
720 FORY=1TO13:Z=Z+1:CS(Z)=X:CV(
Z)=Y:NEXTY,X
730 '---CREATE SYMBOLS
740 DRAW"BM68,156;S8C3R1U1R1D1R2
U2L1U1R1U1R3D1R1D1L1D2R2U1R1D1R1
D3L1D1L1U1L3D2L1U2L3D1L1U1L1U3"
750 PAINT(80,152),3,3:GET(68,148
)-(91,167),C,G
760 DRAW"BM100,156;C4BR1R1U1R1U1
R1U1R1U1D1R1D1R1D1R1D1R1D1L1D1L1
D1L1D1L1D1U1L1U1L1U1L1U1L1U1"
770 PAINT(114,156),4,4:GET(100,1
48)-(123,167),D,G
```

```
780 DRAW"BM132,156;C3BR1R1U1R1U1
R1U1R1U1R1D1R1D1R1D1R1D1R1D2L1D1
L1U1L2D3L1U3L2D1L1U1L1U2"
790 PAINT(146,156),3,3:GET(132,1
48)-(155,167),S,G
800 DRAW"BM164,156;C4BR1U2R1U1R1
U1D1R1D1R3U1R1U1D1R1D1R1D2L1D2L1
D1L1D1L1D1L1U1L1U1L1U1L1U2L1"
810 PAINT(170,152),4,4:GET(164,1
48)-(187,167),H,G
820 SCREEN1,0:FORX=1TO3000:NEXT
830 '---ODDS DISPLAY
840 PRINTSTRING$(8,"*")"C0C0 CAS
INO ODDS"STRING$(8,"*")"
850 DATA 1 ONE-PAIR,2 TWO-PA
IR,3 THREE-OF-A-KIND,4 STRAI
GHT,6 FLUSH,9 FULL-HOUSE,25
FOUR-OF-A-KIND,50 STRAIGHT-FLU
SH,250 ROYAL-FLUSH
860 FORX=5TO10:READA$(X):PRINTMI
D$(A$(X),4);TAB(24)VAL(A$(X))"TO
1":NEXT:FORX=27TO28:READA$(X):P
RINTMID$(A$(X),4);TAB(23)VAL(A$(
X))"TO 1":NEXT:READA$(29):PRINTM
ID$(A$(29),4);TAB(22)VAL(A$(29))"
TO 1"
870 PRINT@416,"YOUR INITIAL BANK
ROLL IS $1000!!":TT=1000:PRINT@4
80,"READY?";
880 IF INKEY$=""THEN880 ELSE CLS
890 '---START PLAY
900 COLOR2,1:PCLS:BT=INT(100*10^
(-TT/20000))*RND(10):BT$=MID$(
STR$(BT),2):DRAW"BM20,20;C4":X$="
Your bet is $"+BT$+"!":GOSUB670
910 DRAW"BM20,40":X$="GOOD LUCK,
PAL!!!":GOSUB670:SCREEN1,0
920 '---CLEAR DECK
930 FOR X=1TO52:DD(X)=0:NEXT
940 FORX=1TO5
950 GOSUB1010
960 Y=12+48*(X-1):Y$=STR$(Y)
970 DRAW"BM"+Y$+",62;C2":X$=CHR$(
X+48):GOSUB670
980 GOSUB1140:GOSUB1020
990 NEXT:GOTO1150
1000 '---DEAL
1010 Z=RND(52):IF DD(Z)=1THEN101
0ELSECD(X)=Z:DD(Z)=1:RETURN
1020 '---CARD GRAPHICS
1030 IF CS(Z)=1 OR CS(Z)=2 THEN
CC$="3" ELSE CC$="4"
1040 IF CV(Z)>1 AND CV(Z)<11 THE
N X$=CHR$(CV(Z)+48)
1050 IFCV(Z)=1THENX$="A"
1060 IFCV(Z)=11THENX$="J"ELSEIFC
V(Z)=12THENX$="Q"ELSEIFCV(Z)=13T
HENX$="K"
1070 DRAW"BM"+STR$(Y+4)+",84;S8C
"+CC$:GOSUB670
```



# SOFT CITY

Your largest single source of programs and products for the COLOR COMPUTER / TDP 100

## **64K TDP SALE: Extended Color BASIC TDP System 100 computers — Full factory packs, with joysticks and manuals! 64K for \$419, 16K for \$369!**

### **ASSEMBLY LANGUAGE STARTER SET**

#### **CCEAD (Eigen Systems)**

This widely acclaimed program may be the best software buy on the market. A two-pass assembler supporting the full 6809 instruction set and addressing modes.

#### **COLOR MONITOR (Tom Mix)**

Powerful monitor written in position-independent-code. Break pointing of ML programs, register display and modify, memory display and modify, etc.

*Buy them both for only \$29.95, and get 6 C-10 data cassettes free! A savings of \$6.00, but only if you order now!*

#### **We are dealers for:**

- AMDEK
- B5
- CHROMATIC SOFTWARE
- COGNITEC
- CONSOLINK
- COMPUTERWARE
- CORNSOFT
- CUSTOM SOFTWARE ENGINEERING
- DATASOFT
- EIGEN SYSTEMS
- FRANK HOGG LABORATORY
- INTRACOLOR COMMUNICATIONS
- MARK DATA PRODUCTS
- MICRO TECHNICAL PRODUCTS
- NEC

### **LIFE IN THE FAST LANE! PROGRAMMER'S 3-PAK**

#### **BASIC AID (Eigen Systems)**

Use it once, and you will never be without it! A real time saver. Takes the drudgery out of BASIC programming with its 2 key command entry and user-definable keys. Auto line numbering and moves.

#### **STRIPPER (Eigen Systems)**

Take the fat out of your programs. Spaces and REMarks are removed to let your new or existing programs run fast.

#### **QUICKSORT (Skyline)**

A machine language sort routine that can be easily used in your programs. BASIC sorts that take hours can be done in seconds with QUICKSORT.

*Buy BASIC AID and STRIPPER for \$42.90, and get QUICKSORT (a \$12.95 value) FREE! Act Now!*

- PEACOCK ENTERPRISES
- PRICKLY PEAR SOFTWARE
- THE PROGRAMMER'S GUILD
- SKYLINE SOFTWARE
- SOFTCORE SOFTWARE
- SPECTRAL ASSOCIATES
- SPEECH SYSTEMS
- STAR MICRONICS
- SUGAR SOFTWARE
- TDP ELECTRONICS
- TRANS TEK
- TOM MIX
- U.S. ROBOTICS
- VERBATIM
- YORK
- ETC., ETC....

### **SKYLINE 64K Memory Upgrade Kits**

8 guaranteed 64K memory chips, solderless installation instructions. Skyline's 64K BOOT and PAGER programs (a \$20 value).

*All for the super-low price of \$49.00!*

*Order yours today!*

### **ORDERING INFORMATION**

**ALL ITEMS SHIPPED  
FROM STOCK**

Phone orders  
may be placed at:

(312) 260-0929  
(Our voice line),

or through our  
Color Computer  
Bulletin Board  
Service:

(312) 260-0640  
(METROWEST BBS)

Mail orders  
and requests for catalogs  
should be sent to:

**SOFT CITY  
442 Sunnyside  
Wheaton, Il  
60187**





```

1080 DRAW"BM"+STR$(Y+24)+"",130":
GOSUB670
1090 ON CS(Z) GOTO 1100,1110,112
0,1130
1100 PUT(Y+8,92)-(Y+31,111),C,PS
ET:RETURN
1110 PUT(Y+8,92)-(Y+31,111),S,PS
ET:RETURN
1120 PUT(Y+8,92)-(Y+31,111),H,PS
ET:RETURN
1130 PUT(Y+8,92)-(Y+31,111),D,PS
ET:RETURN
1140 COLOR2,1:LINE(Y,68)-(Y+39,1
35),PSET,BF:RETURN
1150 '---DISCARDS
1160 DRAW"BM12,160":X$="Discards
?":SOUND100,1:GOSUB670
1170 FORX=1TO4:DC(X)=0:NEXT:A=1
1180 K$=INKEY$:IF K$=CHR$(13)THE
N 1240 ELSE IF K$=""THEN1180ELSE
K=VAL(K$):IFK<1 OR K>5 THEN 1180
1190 IF K$=CHR$(13)THEN1240
1200 IFA=5THEN1180
1210 FORX=1TO5 :IF DC(X)<>K THEN
NEXT ELSE1180
1220 DC(A)=K:A=A+1
1230 LINE(10+48*(K-1),48)-(52+48
*(K-1),136),PSET,B:GOTO1180
1240 DRAW"BM12,184":X$="OK?":SOU
ND100,1:GOSUB670

```

```

1250 K$=INKEY$:IFK$=""THEN1250EL
SEIFK$="Y"THEN1290ELSEIFK$<>"N"
HEN1250
1260 GOSUB1320
1270 FORK=1TO4:IFDC(K)THENGOSUB1
310
1280 NEXT:GOTO1160
1290 GOSUB1320:FORK=1TO4:IF DC(K
) THEN GOSUB1310:X=DC(K):GOSUB10
10:Y=12+48*(X-1):GOSUB1140:GOSUB
1020
1300 NEXT:GOTO1330
1310 LINE(10+48*(DC(K)-1),48)-(5
2+48*(DC(K)-1),136),PRESET,B:RET
URN
1320 LINE(0,140)-(255,191),PRESE
T,BF:RETURN
1330 '---SCORING
1340 LINE(0,0)-(255,67),PRESET,B
F
1350 DRAW"BM12,20":X$="How did y
ou do?":GOSUB670
1360 '---SORT
1370 FORX=1TO4:Z3=X:Z1=CV(CD(X))
:FORY=X TO5:Z2=CV(CD(Y))
1380 IF Z2<Z1 THEN Z1=Z2:Z3=Y
1390 NEXTY:Z4=CD(X):CD(X)=CD(Z3)
:CD(Z3)=Z4:NEXTX
1400 '---TEST STRAIGHT
1410 S=1:SA=0:FORY=2TO4:IF CV(CD

```

## all-in-one Swivel Organizer

"the perfect solution"

- ★ No more fumbling
- ★ nds tangled cables
- ★ Everything you need is at your fingertips
- ★ Unique swivel base

**NO ONE can match these features and Beat Our Prices!**

- Woodgrain FORMICA FINISH (water and stain resistant)
- Swivel base allows sharing of computer  
*Great for game playing and multi-use work stations*
- Storage areas with clamps in rear for dressing cables neatly
- Cut out side allows ROM PACK insertion
- Comes fully assembled

**PLUS Swivel Base Model Available \$24<sup>95</sup> for Terminal Use**



another quality product from

**Shauntronics**

Send check or money order to:

Shauntronics • P.O. Box 131 • Fairview, N.J. 07022

"ALL-IN-ONE" \$34.95  
SWIVEL BASE ONLY \$24.95

SHIP TO:

add \$5.75 each for Shipping & Handling  
New Jersey residents add 6% sales tax

Name \_\_\_\_\_

Address \_\_\_\_\_

City \_\_\_\_\_ Zip \_\_\_\_\_ Phone \_\_\_\_\_

\*Within Continental U.S.A.

**Allow 4 to 6 weeks delivery**

```

(X)))+1<>CV(CD(X+1))THENS=0:GOTO1
440ELSENEXT
1420 IF CV(CD(1))=1 AND CV(CD(5)
)=13 THEN SA=1:GOTO1440
1430 IFCV(CD(1))+1<>CV(CD(2))THE
NS=0
1440 '---TEST FLUSH
1450 FL=1:FOR X= 1TO4:IFCS(CD(X)
)<>CS(CD(X+1))THENFL=0:GOTO1460E
LSENEXT
1460 IFFL AND SA THEN X$=A$(29):
GOTO1630
1470 IFFL AND S THEN X$=A$(28):G
OTO1630
1480 '---TEST 3- OR 4-OF-A-KIND
1490 T(1)=0:T(2)=0:T(3)=0
1500 FORX=1TO3:IFCV(CD(X))=CV(CD
(X+1))ANDCV(CD(X+2))=CV(CD(X+1))
THENT(X)=1
1510 NEXT
1520 IF(T(1) AND T(2)ANDFL=0)OR(
T(2)ANDT(3)ANDFL=0)THEN X$=A$(27
):GOTO1630
1530 IF(T(1)ANDCV(CD(4))=CV(CD(5
)))OR(T(3)ANDCV(CD(1))=CV(CD(2)
))THENX$=A$(10):GOTO1630
1540 IF FL THENX$=A$(9):GOTO1630
1550 IF S THEN X$=A$(8):GOTO1630
1560 IFT(1)ORT(2)ORT(3)THENX$=A$
(7):GOTO1630

```

```

1570 '---TEST PAIRS
1580 PP=0:FORX=1TO4:IFCV(CD(X))=
CV(CD(X+1))THENPP=PP+1
1590 NEXT:IF PP=0 THEN 1620
1600 IF PP=2 THEN X$=A$(6):GOTO1
630
1610 X$=A$(5):GOTO1630
1620 IFRND(2)=1THENX$="-1 YOU H
AVE NOTHING"ELSEX$="-1 WORTHLES
S CARDS"
1630 '---TALLY
1640 OD=VAL(X$):X$=MID$(X$,4)+"!
"
1650 DRAW"BM12,50":GOSUB670
1660 DRAW"BM12,160":IF OD>0 THEN
X$="YOU WON ":SC=BT*(OD-1):TT=T
T+SC:FORX=1TO5:SOUND50,1:SOUND15
0,1:NEXT ELSEX$="YOU LOST ":SC=
BT:TT=TT-BT:SOUND50,5
1670 SC$="$"+MID$(STR$(SC),2):X$
=X$+SC$+"!":IF OD=1 THEN X$="EVE
N MONEY!"
1680 GOSUB670:TT$=MID$(STR$(TT),
2)
1690 DRAW"BM16,184":IF TT<0 THEN
X$="You owe $" ELSE X$="You hav
e $"
1700 X$=X$+TT$+"!":GOSUB670
1710 IFINKEY$=""THEN1710ELSEB90
30000 PCLEAR2:GOTO20

```

Artwork By Jack Keller



# KAMIKAZE

# ARK ROYAL GAMES

P.O. Box 14806  
Jacksonville, FL 32238

Prices on All games  
include shipping. Florida  
Resident add 5% tax.

All Programs require Color  
CompuTer™ (Tandy Corp) or  
TDP System 100 CompuTer™  
(RCA)

**KAMIKAZE 32K EXT** — Fight off Takijiro Onishi's Kamikazes, find and destroy his suicide fleet before it finds you. Hi/res action graphics include: radar, search, mapscreen, fighter vs fighter, torpedo & divebomber, bomber vs ship, Kamikaze attack, and more. Hit table, repair, ready planes, target data, ship vs ship, Joystick option. 4 Levels.



**Cassette** ..... **\$24.95**

**KAMIKAZE 16K EXT** — Not as extensive as its big brother but with enough 'boardgame' strategy to make it more than another shoot-em-up. Using your 12 ships and 68 fighters, search & destroy Kamikazes. Joystick option, play levels.

**Cassette** ..... **\$19.95**

**ACROSS THE RUBICON 16K EXT or NON EXT** — The popular WWII wargame. Break thru the Huertgen Forrest using infantry, heavy and light tanks, air & artillery strikes Paratroops. Graphics, terrain modifiers, unit designators and 5 minute conversion instructions for 16K NON EXT. State system when ordering.



**Cassette** ..... **\$19.95**

From STRICTLY COLOR SOFTWARE

**MISSION EMPIRE!** A strategic wargame/strategy game. Starting with one planet, incomplete intelligence and limited resources, you must conquer the rest of your galaxy. Play takes 2-5 hours and is DIFFERENT EVERY TIME! All versions offer GAME SAVE option. Specify 32K disc or 16K-The 32K versions require Extended Basic, the 16K does not. The disc version is shipped on a cassette with instructions for transferring to disk. If you want disc, add \$3.00.



**Cassette** ..... **\$19.95**

# Keeping The Loathsome In Line

*(Better Monster Management)*

By Bill Nolan

*Rainbow* Contributing Editor

I was looking through my local game shop the other day, and I couldn't help but notice that there are at least 20 different fantasy games being sold. While they have their differences, there *are* similarities between them. In general, they are all horribly complex, badly written, and fun to play. The fantasy gaming genre is such a good idea that it rises like a Phoenix from the ashes of confusion and contradiction. I am truly amazed that anyone ever learns to play these games. One of the most popular has five (yes, five—count them) large, hard-cover books of rules, and fully two of these books are devoted to monsters!

With all of these monsters, it's no wonder I can never remember any specifics about a certain one. How many times does it attack? How much damage can it do? How tough is its skin? How fast (or common, or large, or smart) is it? Look it up—that's what I have to do.

The other day it came to me in a vision that I had a computer, and that it could be possible to keep track of one or two hundred monsters, somehow, inside the computer's capacious memory banks. (I hope their claws don't catch on the wires!) It seems to me that if the phone company can keep track of everyone in the world on their computer, I should be able to handle a few dragons and such on mine.

As I thought about this, I came up with a list of requirements for the program:

- 1) It had to be simple enough for me to understand;
- 2) It had to be easy to add monsters; and
- 3) It had to be able to sort the monsters by any criteria I wanted.

Number one was automatic—if I wrote it it would have to be simple enough for me to understand. Number two could be solved by putting each monster in its own *DATA* line. In this way, new monsters could be added by simply adding another *DATA* line to the end of the program.

Number three was a little more complex. Before I could solve this one, I had to decide what information I would store about each monster. I came up with the following: name, size, hit dice, armor class, number of attacks, damage per attack, special attacks, special defenses, magic resistance, intelligence, and alignment. That was 11 things all



together, and what I wanted was a program that would call up a monster by name, or would call up—one after the other—all large monsters, or all small, or all with six hit dice, or all with poison, or all with armor class lower than two, or . . . well, you get the idea.

At this point I could see that the program itself was going to be fairly short. Most of the space was going to be for *DATA*. To accomplish the above goals, I needed to be able to search the *DATA* on any one of the 11 criteria, and print any matches to either the screen or printer (or both). This record-keeping was starting to look easy, and I began to see how even the phone company could do it. I would need a menu asking the menu which criteria they wanted to search, and then, depending on their choice, I would have to get the target values. If you are new to searches, let me explain about targets. Suppose I have a mailing list, and I want to print out all the people named Smith. Smith becomes the target, and I go through the list one record at a time and compare the last name of the person to the Target. If the person's name happens to be Smith, then the search string will match the target, and the computer will do whatever you told it to do when this happens.

I wanted to be able to search for not only a specific target, but also for a specified range, and that was the hard part, since some of my targets would be strings and others would be numbers. I decided that the easiest way to do this would be to have two completely separate search sections. Next month I will give you the complete program.

This type of program is very flexible. If you don't like monsters, you could use it to keep track of a mailing list, or a collection, or most any kind of information. This kind of program is called a data base, and I will tell you how to modify this one for various uses. Keeping the data in *DATA* lines is not the best way to handle a data base, but it is easy to use and understand, and you can switch to another system as your needs become more sophisticated.

As usual, let me know right away if I forgot anything important. I look forward to seeing many of you in Chicago at Rainbowfest.





# “WANNA FIND OUT WHAT FUN REALLY IS?”

THE KIND OF EXCITEMENT YOU GET OUT OF YOUR SYSTEM DEPENDS ON  
WHAT GAMES YOU PUT INTO IT.

If You Want to Find Out What it's Like to Use your Computer to its Fullest...Then These are the Games  
You'll Need! FOR YOUR TRS-80 COLOR COMPUTER

## Dunkey Monkey

32K EXTENDED BASIC NOT REQUIRED

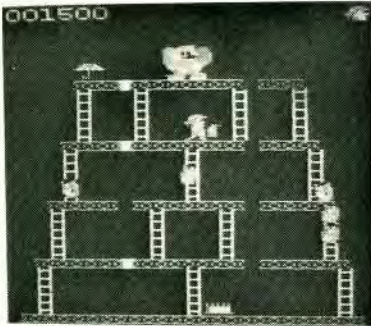

ON THIS SCREEN:  
Pop the Rivets and Fight Fires

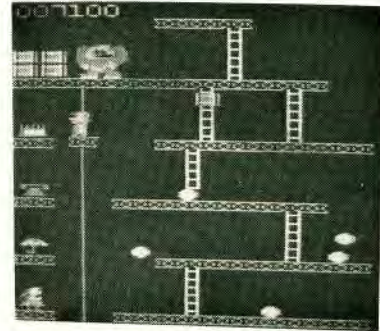

ON THIS SCREEN:  
Jump Barrels and Ride the Elevator

We're sure you already know the rules to this game! As game progresses so does the difficulty level.

Cassette ..... \$24.95  
Diskette..... \$29.95

ULTRA-FAST MACHINE LANGUAGE ■ HIGH RESOLUTION GRAPHICS ■ SPECTACULAR SOUND EFFECTS

## STARFIRE

16K EXTENDED BASIC NOT REQUIRED

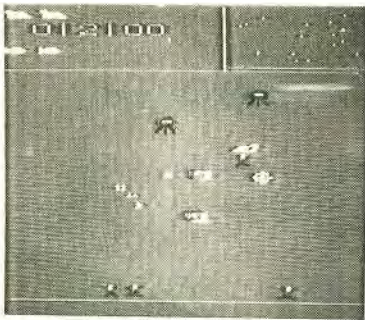

Plays like popular arcade game Defender™ including:

- Hyperspace
- Smart Bombs
- Radar Scanner

Cassette ..... \$21.95  
Diskette..... \$26.95



Give your Color Computer  
a New Image!



## SCREEN - 64

64 Characters X 32 Lines  
Upper & Lower Case

16K EXTENDED BASIC NOT REQUIRED

1. Load in SCREEN-64
2. Type EXEC
3. You're Back in BASIC with a 64 x 32 Screen plus...

FEATURES:

- Slow/Fast Scroll Selectable
- Window Capabilities
- Text & Graphic on same screen
- Superscript/Subscript
- Reverse Screen/Reverse Video
- No Hardware Modification Needed

Cassette ..... \$19.95  
Diskette..... \$24.95

## Intellectronics Ltd

22 Churchill Lane  
Smithtown, N.Y. 11787  
(516) 543-6642

DEALER INQUIRIES INVITED

We pay all shipping. All orders shipped in 24 hours. N.Y. residents please add sales tax. Canadian orders please send M.O. in U.S. funds only.

## PRINT #-2,

of programs by others are allowed.

We expect the simulation contest will be a lot of fun. The top winning programs will be published in *the Rainbow*. Other winners may be included in a book.

And speaking of books, we plan to announce shortly the publication of our first book, *the Rainbow Adventure Book*. It will contain all the winning Adventures from our recent contest. This is in response to requests from many of you for a compilation of all the winning programs from our recent contest.

In the way of finally, I have received a couple of letters in recent weeks asking whether we plan to have a reader service card available in *the Rainbow*. My initial reaction is "no." And the reasons why are simple:

First of all, reader service is slow. If you are interested in a product, you are interested in it *now*, not six weeks from now. In fact, reader service—to my mind, anyway—is more a service to a *publication* than to the readers (or the advertisers). Let's face it, a lot of people who really aren't very interested in a product will check a reader service card. But, it *does* make the magazine look good to the advertiser to deliver a lot of names and addresses.

No matter if it takes four to five weeks to deliver those names. And, while that does not serve the reader particularly well, it does serve the magazine. I think it is self-serving.

But it is also expensive. And that is the other reason we have not offered reader service cards.

First, it is expensive for the magazine to print such cards, and to operate the reader service system—especially when it is contracted to an outside firm, as most are. Who pays for that? Not the magazine. And not the advertiser. You do. Through increased prices for products.

In addition to that direct expense, the advertiser then must mail something to everyone who fills out a reader service card. And, remember, that message arrives five to six weeks after the person has expressed an interest.

We get reader service from several of the publications in which we advertise *the Rainbow*. First of all, response is low (if someone is interested, he or she will usually write direct). Second of all, we see a great deal of repetition—the same persons checking the cards over and over again. And third, we see evidence a great number of people check every single entry on the card.

In sum, we think the reader service card is a slow way to request information; that it drives up the price of products; and that it is often used more as an advertising selling tool than as a service to readers.

But, maybe we're all wet. As always, if you—*our readers*—think a reader service card is that important, then we will certainly consider instituting one. I would, as always, welcome your input into the issue.

—Lonnie Falk

## RAINBOWfest

Chicago

April 22-24

Hackers' Helper . . .

## Canadian Offset

Edgar Poulin, of Sherbrooke, Quebec, Canada, offers a method of using an offset in loading machine language programs to disk if this is to be different from the *SAVEM* location. "Instead of calculating the offset, I let my 80C do the hard work."

Ed's method:

A — If the new location is to be in higher memory than the old.

`LOADM "Filename", (new start address - old start address)`

Examples:

`LOADM "NAME", (&H7000-&H3C75)`

`LOADM "NAME", (28672-15477)`

Both will work.

B — If the new location is to be lower in memory than the new.

`LOADM "Filename", (new start address - old start address + 65536)`

`LOADM "NAME", (&H3C75-&H7000) + 65536`

`LOADM "NAME", (15477-28672) + 65536`

Again, both will work.

Use the last number in decimal as 80C will not recognize &H10000 (which is 65536). If anyone insists on only hex, 65536 can be replaced with &HFFFF + &H1.

Another little item Ed offers will interest those with a disk system in merging and running two programs.

`MERGE "FILE NAME", R`

"This command will merge the two programs together and automatically run them. It is great for header listings to the printer," explains Ed, adding that "it is these little unknowns that make the 80C a pleasure to work with."

Hint...

## LISTEN UP

So, you've got an IO error on the first save of your favorite program, and you can't remember how far in the second save is. What to do? Just keep typing `CLOAD` until the second save finally comes up? Steve Lipps of Circle City Software has a better idea. If you put a little space between your saves, as many of us do, then you can listen for the second save. Says Steve, "Just use `AUDIO ON: MOTOR ON` and listen for the silent space. Then you can use `MOTOR OFF`. Even faster than `MOTOR OFF` is to hit any key and then `ENTER`, creating a syntax error which will stop the recorder." Then `CLOAD` the second save.

Of course, this isn't something you want to do every time you load the program, so use the tape recorder counter and note where the first save ends. Now, with the "record" and the "play" buttons down, start from the beginning of the tape and use `MOTOR ON` until you reach the same spot and stop by creating a quick syntax error. This will erase the entire listing; it was bad anyway, right?

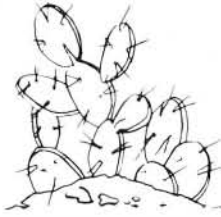

# PRICKLY-PEAR SOFTWARE

## QUALITY PROGRAMS FOR YOUR COCO & TDP-100

PROGRAMS REQUIRE 16K EXTENDED BASIC FOR TAPE, AND 32K DISK UNLESS OTHERWISE NOTED.

### DISK UTILITIES

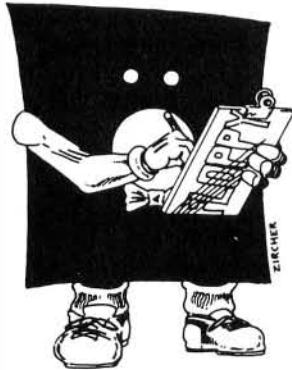

#### The Disk Manager

If you use a disk drive you NEED this program! It does more than any other disk utility. You can use it to rebuild a crashed disk easily - two different ways. You can also print a SUPER DIRECTORY for a disk that contains such information as program size, which granules are used, and the start, end, and execute addresses for machine language programs. It will also print a menu on the screen for a disk in the drive, and when you indicate your choice it will load and either RUN or EXEC the program for you as appropriate. In addition, it codes your files by DATE, and it codes your disks by NAME and NUMBER. And, it creates and maintains a file of all your disks (and the programs on them) which you can sort and print as needed. You can sort a collection of up to 300 disks. Could you use a printed list of EVERY program in your collection, in alphabetical order? This list tells you which disk has the program you need so you can find it easily, and all this is only the beginning. There are so many features we have no space to mention them all. Both the 16K and 32K versions are included, and we suggest you place a copy of the program on every diskette for quick access. You will wonder how you got along without this beauty!! Full, easy to follow instructions. Requires a disk drive. **\$29.95**

### NEW THIS MONTH

#### The Disk Master

This helpful addition to your library performs a whole list of great functions. We've seen programs selling for just as much that do only one or two of these things, and the whole thing is menu driven for ease of use. It provides a speed check and adjustment function to get your drives into perfect adjustment. It moves programs from tape to disk — or disk to tape — or from one drive to another — all effortlessly. It prints a directory — with machine language addresses — to the screen or printer. It gives you two different disk maps. One shows which sectors are used in each gran, and the other shows which gran are available. It even gives you a way to easily purge a number of files from a crowded disk. Why buy a different program for every function, when this does so much? Requires a disk drive. **\$24.95**

Your Personal check is welcome - no delay. Include \$1.50 shipping for each program ordered. (Shipping free on \$50.00 or larger orders). Az. residents add 6% sales tax. Orders shipped within two days.

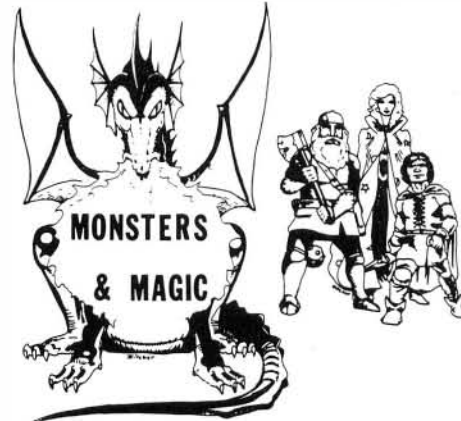

#### Monsters & Magic

The most realistic fantasy role-playing game yet for the Color Computer. You start out by rolling up your character's basic ability scores and buying equipment. When you are ready it's into the dungeon. Your character starts at first level, but can rise in levels by garnering experience in the fray. If you have role-played fantasy games you will be amazed at the realism of the combat system. Armor class, initiative, and damage by weapon type are all included, with over 50 different monsters to fight - each with it's own abilities. As you rise in level you can win treasure and magic weapons and spells - if you live!! You set the battle length by telling how many monsters you want to fight before you reach your final battle to the death against the powerful Dungeon Lord. There are 1000+ place description combinations in this text based game, and real excitement in every one! This is a fantasy simulation, and is truly not like any adventure game you have ever seen. For 1 player; requires 32K extended BASIC. **TAPE - \$19.95, DISK - \$24.95**

#### Astrology

Truly a classic, this program will accurately cast your complete horoscope. You just enter the date, time, and place of birth. The sun sign, rising sign, mid heaven (MC), lunar nodes, and planetary influences including houses and aspects between the planets will all be calculated, and a full chart drawn. You can also do progressed charts and transits. It will even tell you the day of the week you were born. The accompanying book will help you interpret this chart of your horoscope. The extent of the documentation is tremendous, even by our exceptionally high standards, and no previous knowledge of the subject is required. You can share in this wisdom which has been used for thousands of years in many cultures. This program was written by a professional Astrologer. Please specify 16K or 32K system. **\$34.95 tape — \$39.95 disk**

Stocked by Quality Dealers, or

Send Order To: **PRICKLY-PEAR SOFTWARE**  
9822 E. Stella Road  
Tucson, Arizona 85730  
(602) 886-1505



# Learning To Live With A One Disk System

By Melvin Hefter

After working with large and medium size computer systems for many years, I know that one never configures a computer system with only one disk drive. Even if the total on-line storage capacity is not required, ease of disk backup makes an extra drive worthwhile. With this knowledge in hand, when I got my Color Computer I got it with only one disk drive. I knew I could always expand later.

As I read through the disk manual, I saw that there was a backup capability provided, even for single disk systems. My disk backup problems were solved! I would just routinely use this capability to protect myself. I had only a few files on my first disk. I put in the command `BACKUP0` and was told to put in my source disk. A few whirls of the disk and I was told to put in the destination disk. That seemed fair enough. A few more whirls of the disk and it told me again to put in the source disk. But wait a minute! I know my 32K machine can hold all I had on that source disk at one time. I dutifully complied, and complied, and complied for six cycles. Then it became obvious that the `BACKUP` command must be doing a physical copy; that is, copying all parts of the disk whether used or not, as opposed to a logical copy of just the used areas. The physical copy is a valuable capability for disks which may be used in a nonstandard manner, but I would have liked to have had the other option for my few files.

Being human and recognizing that my disk drive was quite reliable, I soon got out of the habit of routinely backing up my disks as often as I should. And then, of course, I had my first disk I/O error. Not only could I not get the file I wanted, I could not list the disk contents with the `DIR` command. I licked my wounds and went back to my now too-old backup disk and started to redo what I lost.

I soon found out that when disk I/O errors occur they tend to come in bunches. I got the connection, turned off my computer, disconnected all of the connections, reconnected them, and my problems went away. Not only did I find that most of my disk problems were connector related, I also found that when I had a problem, it almost always resulted

in the disk directory being damaged and the total disk content becoming inaccessible.

Time to go back to the disk manual for some serious study. I found that the control and index information is contained in track 17 of the disk. I also found that only sectors 2-11 (out of a total of 18 sectors) were used for the needed information and that the rest of the sectors were reserved for future use. But I figured that while I was waiting for that future use I might get some benefit from those unused sectors now. Why not duplicate the directory information in those unused sectors so they can be reclaimed if the real directory information becomes unreadable?

Sector 2 of track 17 contains a file allocation table showing which granules on the disk are used and how they are related to each other. I could duplicate this in unused sector 1. The other nine sectors (3-11) contain such information as the file name and type. I have only seven sectors of track 17 available (12-18) so two sectors will go unduplicated. Actually, this is not a problem since all nine sectors of directory information would be used only with a full disk and no files taking up more than one granule. The 56 files which can be kept in seven sectors have been plenty.

I generally use the `VERIFYON` command so that I know when I have a problem as soon as possible. The program I use for duplicating and restoring the needed directory information is a simple one that I run in a few seconds whenever I add a file to my disk or make any significant changes. A `RUN` command duplicates the information. When I have a problem and the `DIR` command results in an I/O error, a `RUN 100` command will restore the directory to its configuration during the last run of this program. If the `DIR` works OK, do not use this recovery procedure. Just accept the loss of one file. I keep a copy of this program on each of my disks so that it is easily available for running and always conveniently available when I have a problem.

This procedure is not perfect and will not guarantee total recovery of all data. If a file has been changed since the last run of the program, you may lose the last few lines or end up with garbage at the end. If you have a bad sector in the data file, that file may be unrecoverable, but the rest of the disk will be accessible. If you actually have a bad spot on the disk on the directory track, as opposed to just a bad disk write, it may not work. I also supplement this procedure with some common sense precautions like storing important files on more than one disk, treating the disks with the kind of gentle treatment they do require, keeping my connections clean, and using the `BACKUP` command to produce total duplicates of disks I cannot afford to lose.

I have found that an imperfect procedure used frequently is better than a perfect procedure that I do not use!

*(Mr. Hefter is president of Custom Software Engineering of Cocoa Beach, Florida.)*

## EPROM PROGRAMMER 1K-16K X 8

PLUGS INTO CAR. SLOT OF THE 80C (16K). PROGRAM (ML) ON CASS. CONTAINS: ERASED?-PROGRAM-VERIFY -MOVE ROM-RAM-EXAM/CHANGE MEM. COMES WITH 5-P.M.'S FOR 1-8K EPROMS IN THE 25/2700 SERIES (5V ONLY) \$85. OTHER P.M.'S AVAILABLE FOR 16K AND 68700 SERIES FOR \$5 EA. EPROM ERASER FOR \$85 HAS A 44-CHIP CAPACITY. SOON TO BE RELEASED, A MONITOR THAT WILL TRACE/SINGLE STEP RAM OR ROM!! ALSO AVAILABLE 28-24 PIN ADAPTERS FOR USING 2764 OR 2564 EPROMS IN THE BASIC OR EX. BASIC SOCKET \$3.50 / 2-\$6 (SPECIFY TYPE). ALLOW 2-WEEKS FOR PERSONAL CHECKS TO CLEAR BANK. ADD \$2.50 FOR POSTAGE.

INTRONICS  
(913) 422-2094

P.O. BOX 13723  
EDWARDSVILLE, KS. 66113

# Color Computer Power!

## DATAFILE

\$24.95

A unique, multipurpose data storage system. DATAFILE is a sophisticated, non-formatted type database, with user-defined categories. It performs string searches, deletes, sorts, merges and prints in various formats. Using your disk drive, DATAFILE works with files larger than available RAM. Save and load files from tape or disks. Line edit, change or add data commands. Numerically labels all records. Displays remaining memory available. DATAFILE is ideal for mailing lists, cataloguing, sales files, record systems, etc. Complete documentation, on-screen help and a sample file are included.

## DATAFILE 64k

\$29.95

All the features of the above with much more memory space. Ideal for small business applications. Documentation is available for \$5. and is refundable with your order.

## DISKPRO

\$29.95

No more crashed disks! This program could be a lifesaver. DISKPRO creates back-ups of your disk directory and allocation tables. Disk crashes are easily restored with DISKPRO. Also included is INDEX, a directory utility program. Both programs come on disk with complete documentation.

Draw electronic circuits with our...

## Electronics Drafting Board

You can design wiring diagrams easily with our Electronics Drafting Board. Create complex electronic plans, label components, erase, etc. and then have a finished schematic from your printer. Screen print routine and disk I/O included. Comes with sample schematic file and excellent documentation. Electronics Drafting Board is fun to use and will save you hours of work.

\*6 viewing windows on a 480X540 pixel work sheet\*Joystick or arrow-key control\*Text labels components on screen\*All electronic symbols\*Complete documentation with onscreen help\*Prints finished schematic to any Epson MX (with Graftrax) or Radio Shack printer\*Disk save/load.

Requirements: 64K Color Computer with Extended Basic, disk drive and (optional) printer. \$39.95 includes operating manual, program on disk, postage & handling.



## PAINTPOT

Bring out the artist in you and your family! With PAINTPOT you can create fast, effortless sketches and drawings. PAINTPOT gives you joystick or keyboard control on 4 screens. (3 screens on 16K) There are 4 cans of paint to play with! A touch of a key starts animation effects flashing from screen to screen. Your works of art can be saved or loaded from cassette or disk and, with our Screen Print Program (see below) you can have a hard copy on your printer. PAINTPOT comes with complete documentation and a help screen is available. Great fun for kids and creative adults!

\$24.95 on cassette, \$29.95 on disk. Both 16 & 32K on the same tape/disk. Extended Basic required.

## SCREEN PRINT

For use with Epson MX-80/100 printers. Three print formats, all versions of Basic, PMODES 0, 2, 3 & 4. Normal or negative image. Complete documentation. Many useful features!

\$14.95

TTD \$14.95 DTT \$14.95

Transfer your programs to disk or tape effortlessly. Allows you to individually select or mass copy programs.

## SPIDER ATTACK

Shoot-em up action! Try to stop our invading spiders with your joy-stick controlled laser gun. Watch out you don't get eaten!

\$14.95

## MILLBORN

Like to play cards? From France we bring you this popular card game for COCO. Lots of fun!

\$14.95

BEETHOVEN'S FIFTH \$14.95

WILLIAM TELL OVERTURE \$14.95

You really won't believe the incredible music coming from your Color Computer! "It is without a doubt the best example of computer music I've ever heard." (Color Computer News magazine) Now you can enjoy these high quality machine language programs at an affordable price. Specify Beethoven or William Tell when ordering. Two versions, 16 & 32K available on the same tape or disk.

## BLACKBOX

Transmit your programs, machine language, basic or files over the phone. And you don't need a modem! Switch on BLACKBOX and when you load or save a program, you automatically have a copy at a friend's house. Two BLACKBOX's are needed, one for each end of the connection.

\$69.96 each \$125.00 for two

## STARS

Educational and entertaining. STARS creates a dome of the night sky on your TV. Constellations, stars and other naked eye objects are drawn using Extended Resolution graphics. Horizon views show planet positions after sunset. Detailed documentation.

\$19.95

## COLORSHOW

Music, Color and your COCO! Just load in COLORSHOW, connect the small recorder plug to your stereo (or simply put a musical tape in your computer's tape recorder) and watch the fun. Having a party? Turn off the room lights and turn up the music.

\$14.95

Add \$1.50 postage on each software. Programs available on disk for \$5. extra. We pay high royalties to software authors. For more information on this or any of our products, write!

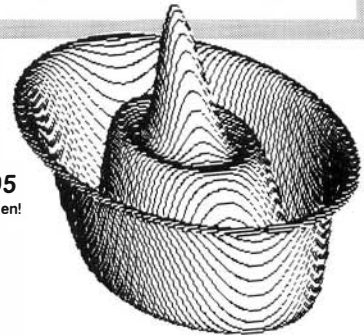

**ilume** design

Dept. T, 4653 Jeanne Mance St.,  
Montreal, Quebec, Canada H2V 4J5

# Super "Color" Library™

For the TRS-80 Color and TDP System 100 Personal Computers

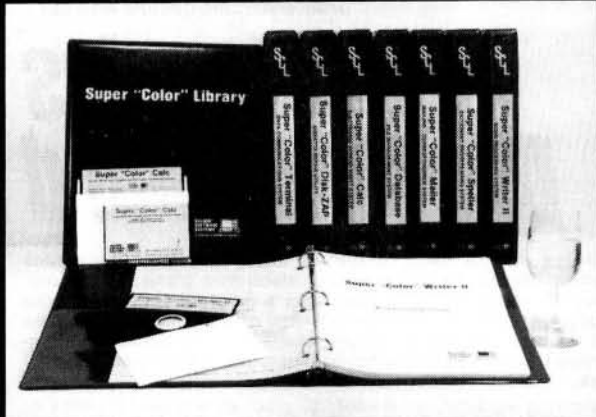

No matter what kind of problem you are trying to solve with the Color Computer, there is a program in the ever-expanding integrated, **Super "Color" Library** that will give you the solution; Faster, Better, Smarter!

Every Library program features **MEMORY-SENSE** to determine your computer's memory, from 16 to 64K, and adjusts automatically to maximize work space. All programs, except the **Super "Color" Speller** and **Super "Color" Disk-ZAP**, feature a true lowercase display with below line descenders. Each program has been written specifically for the Color Computer in fast machine code to be totally compatible for optimum performance — Something a motley assortment of programs from diverse sources or a passel of overpriced, wallet-FLEXing software from a bygone era simply can not achieve.

The **Super "Color" Library** has all the power, speed, dependability and compatibility you will ever need so build your library a volume at a time or put the full power of the complete library of problem solvers to work right away.

**64K**  
Compatible

— NEW! —

## Super "Color" Writer II™

VERSION 3.0 By Tim Nelson  
THE INTELLIGENT WORD PROCESSOR

32x16 &  
51-64-85x21&24  
WITH REAL  
LOWERCASE  
DISPLAY

The **Super "Color" Writer II** is for those who desire the best. It is the most powerful, fastest, most dependable and versatile word processor available for the Color Computer, from 16 to 64K. The **Super "Color" Writer II** has features for the most demanding professional, yet it is easy enough for newcomers to master.

Of course the **Super "Color" Writer II** has all the features you would expect from the highest quality word processor, such as a clear, crisp and readable professional display with your choice of display colors, 9 display formats; standard 32x16 & 51-64-85x21 & 24 with real lowercase descenders; full 4-way cursor control, sophisticated edit commands, the ability to edit any BASIC program or ASCII textfile, seven delete functions, locate and change, wild card locate, a real block move & copy, word wrap-around, programmable tabs, display memory used and left, non-breakable space, multiple headers and footers, dynamic text formatting, comprehensive format parameters, use with ANY printer at any baud rate from 110 to 9600 baud, automatic justification, automatic pagination, automatic centering, automatic flush right, underlining, superscripts, subscripts, pause print, single-sheet pause, optionally print comments, append text files, available in a ROMPAK cartridge for maximum work space, but that's only half of the story. No other program can even begin to compare in features with the **Super "Color" Writer II**.

### Check These Exclusive Features

**MEMORY-SENSE** adjusts to computer's memory (16-64K) for maximum work space; **TYPE-AHEAD**, **TYPAMATIC KEY REPEAT** and **KEY BEEP** for the pros; 3 **PROGRAMMABLE FUNCTIONS**; **AUTO PHRASE INSERT**; **COLUMN CREATION**; **TEXT FILE LINKING**; **HELP MENU**; A **TRUE EDITING WINDOW** IN ALL 9 DISPLAY MODES; **TRUE FORMAT WINDOW** to display line lengths up to 255 characters, with horizontal and vertical scrolling to replicate the printed page including centered lines, headers, footers, page breaks, page numbers, margins, giving a perfect printed document every time. Also makes hyphenation a snap; **TRUE AUTOMATIC JUSTIFICATION** for neat, even left and right hand margins; Ability to use **CHARACTER CODES** for printing special characters available with your printer; freedom to embed as many **PRINTER CONTROL CODES** as desired anywhere in the text, **EVEN WITHIN JUSTIFIED TEXT**; 90-plus page tutorial manual.

**ADDITIONAL DISK FEATURES:** Read a directory, Display free granules, Save with Automatic Verification, Load and Append ASCII files, and BASIC programs, Kill files, and Link files from disk for continuous printing. 54K bytes of workspace available with a 64 K system. Only the best offers all of these features.

TAPE \$69.95      ROMPAK \$89.95      DISK \$99.95

Tutorial only \$15.00 (Refundable with purchase)  
Tape & Disk require 32K for lowercase display  
Previous **Super "Color" Writer II** owners call for upgrade policy.

## Super "Color" Mailer™

By Tim Nelson

The **Super "Color" Mailer** is a powerful multi-purpose mailing list merging and sorting program including lowercase display that uses files created by the **Super "Color" Writer II**. Combine files, sort and print mailing lists, print "Boilerplate" documents, automatically insert text in standardized forms, address envelopes, the list is endless.

TAPE \$39.95      DISK \$59.95  
Operators Manual only \$10.00 (Refundable with purchase)

## NEW Super "Color" Speller™

By Peter A. Stark

The **Super "Color" Speller** is a fast machine-code proofreading program to correct **Super "Color" Writer** files. Automatically proofreads your documents against a 20,000 word stock dictionary, plus your own customized dictionary and corrects typos or marks them for special attention.

AVAILABLE ON DISK ONLY \$69.95  
Operators Manual only \$10.00 (Refundable with purchase)

NELSON SOFTWARE SYSTEMS    9072 Lyndale Avenue So., Minneapolis, Minnesota 55420    612/881-2777



# 32x16 & 51-64-85x21&24 Display With Lowercase Descenders And **16** Thru **64K** Too!

## **NEW** Super "Color" Calc™

ELECTRONIC SPREADSHEET By Kevin Herrboldt

Now you can answer those "What if?" financial projection, forecasting, budgeting, engineering and calculating questions with precision, speed and power using the **Super "Color" Calc**, truly the finest electronic worksheet and financial modeling program available for the Color Computer, from 16 to 64K. Now every Color Computer owner has access to a calculating and planning tool rivaling VisiCalc™ containing all its features and commands and then some. You need only change one variable and you instantly see how that change affects your assumptions. You can even use VisiCalc templates freely with **Super "Color" Calc!** Combine spread sheet tables with **Super "Color" Writer II** documents to create ledgers, projections, statistical and financial reports and budgets.

**Features include:** 9 display formats; standard 32x16 & 51-64-85x21&24 with real lowercase descenders \* MEMORY-SENSE to adjust to computer's memory (16-64K) for maximum work space; Full-size 63x256 worksheet \* Easy to use \* HELP Menus to make learning faster \* Machine code speed and high precision \* Total flexibility in calculating \* Up to FOUR VIDEO DISPLAY WINDOWS to compare and contrast results of changes \* Sine and Cosine functions, Averaging, Exponents, Algebraic functions, and base 10 or 16 entry \* Multi-layered Column and Row Ascending and Descending sorts \* Locate formulas or titles in fields \* Easy entry, replication and block moving of frames \* Global or Local column width control up to 81 characters each \* Create titles of up to 255 characters \* Typamatic Key Repeat \* Key beep \* Type-ahead \* Print up to 132 column worksheet \* Prints at any baud rate from 110 to 9600 \* Print formats savable along with worksheet \* Enter control codes for customized printing.

**DISK FEATURES:** Read a directory; Display free granules; Kill files, Save with Automatic Verification; Load files; Append disk files for complete worksheet printing. 54K bytes of worksheet space available with a 64K system.

Tutorial and sample templates are supplied with the program.

**ROMPAK \$89.95** **DISK \$99.95**

Tutorial only \$15.00 (Refundable with purchase)  
Disk requires 32K for lowercase display.

## Super "Color" Disk-ZAP™

By Tim Nelson

Now the dreamed-of repair of I/O errors is a reality. The **Super "Color" Disk-ZAP™** is the ultimate repair utility for simple and quick repair of all repairable disk errors. Designed with the non-programmer in mind, the **Super "Color" Disk-ZAP™** will let you retrieve all types of bashed files, including BASIC and Machine Code programs.

This high-speed machine code disk utility has a special dual cursor screen display to show HEXIDECIMAL and ASCII displays simultaneously. You are able to: Verify or modify disk sectors at will \* Type right onto the disk to change unwanted program names or prompts \* Send sector contents to the printer or any other RS-232 device \* Search the entire disk for any grouping of characters \* Copy sectors \* Backup tracks or entire disks \* Repair directory tracks and smashed disks \* Full prompting to help you every step of the way \* 50-plus page Operators Manual which helps you simply and quickly fix the vast majority of disk errors, and teaches the rudiments of disk structure and repair.

**AVAILABLE ON DISK ONLY \$49.95**

Operators Manual only \$10.00 (Refundable with purchase)

**NELSON  
SOFTWARE  
SYSTEMS**



9072 Lyndale Avenue So. 612/881-2777

A Division of Softlaw Corporation Minneapolis, Minnesota 55420 U. S. A.

TRS-80 is a trademark of Tandy Corp. Visicalc is a trademark of VisiCorp.

**WE TAKE THE COLOR COMPUTER SERIOUSLY.  
AUTHORS' SUBMISSIONS ARE ENCOURAGED.**

## Super "Color" Terminal™

THE FINEST TERMINAL PROGRAM ANYWHERE!  
Version 3.0 By Dan Nelson

The best has become even better, with many new features including 9 display formats; 32x16 & 51-64-85x21&24 with real lowercase descenders, plus compatibility with the 64K Color Computer. This user-friendly program makes communicating with ANY computer a breeze even for a newcomer. Communicate using your modem with all the popular information services such as Dow Jones, Compuserve, The Source, and local BBS's, clubs, friends, or the main-frame at work. You can also communicate directly with other microcomputers, such as the TRS-80 I/III, II, other Color Computers, Apples, IBM PCs, etc., via RS-232 without using a modem. Save the information or PRINT IT!

**FEATURES:** MEMORY-SENSE to adjust to computer's memory (16-64K) for maximum work space; Selectively print data at baud rates from 110 to 9600 \* 54K of data storage with 64K disk system. 128 character ASCII keyboard \* Automatic graphics mode \* Word mode (word wrap) for unbroken words \* Send & receive **Super "Color" Writer II, Database & Calc** files, ASCII files, Machine Language & BASIC programs \* Set communications baud rate from 110 to 9600, Duplex: Half/Full/Echo, Word length: 5 6 7 or 8, Parity: Odd/Even or None, Stop Bits: 1-9 \* Local linefeeds to screen \* Save and load ASCII files, Machine Code & BASIC programs \* Unique CLONE feature for copying any tape \* Lower case masking \* 10 Keystroke Multiplier (MACRO) buffers to perform repetitive pre-entry log-on tasks and send short messages \* Programmable prompt or delay for send next line \* Selectable character trapping \* Files compatible with other Library programs.

**ADDITIONAL DISK FEATURES:** Works with up to four Disk Drives; Call a directory, Print free space, Kill disk files, Save with Automatic Verification and Load textfiles or BASIC programs; Save and Load KSM'S to the disk.

**TAPE \$49.95** **ROMPAK \$59.95** **DISK \$69.95**

Operators Manual only \$10.00 (Refundable with purchase)

Previous **Super "Color" Terminal** owners call for upgrade policy.

## **NEW** Super "Color" Database™

By Dan Nelson

This high speed machine language program including true lowercase displays fills all your information management needs, be they for your business or home. Inventory, accounts, mailing, lists, family histories, you name it, the **Super "Color" Database** will keep track of all your data.

The **Super "Color" Database** features MEMORY-SENSE to adjust to computer's memory (16-64K) for maximum work space. It is structured in a simple and easy to understand menu system with full prompting for easy operation. Your data is stored in records of your own design, each divided into as many fields as you need. All files are fully indexed for speed and efficiency. Full sort of records is provided for easy listing of names, figures, addresses, etc., in ascending or descending order. The math package performs arithmetic operations and updates other fields which is especially useful when used as an order entry and invoicing system. You can create reports, or lists for mailings, or whatever. Create files compatible with the **Super "Color" Writer II and Terminal**. Up to five different print formats are available, and control codes may be imbedded for customized printing.

**AVAILABLE ON DISK ONLY \$79.95**

Operators Manual only \$10.00 (Refundable with purchase)

**For Orders ONLY Call Toll Free**

**1-800-328-2737**



Customer service and product support call (612) 881-2777.

MAIL ORDERS: \$3 U.S. Shipping (\$4 CANADA, \$10 OVERSEAS)

Personal checks allow 3 weeks. **ORDERS SHIPPED SAME DAY!**

**Available at Dealers everywhere.**

**If your Dealer is out of stock ORDER DIRECT!**

# Everything You Wanted To Know About Hex...

By Jim Schmidt

One of the more difficult concepts in the world of computers is that old devil—Hex! The fact that most of us were born with only ten fingers and toes seems to make grasping the concept of another number base more difficult than it should be. Over the years it has sometimes fallen to me to instruct novices in programming on this subject. Most professional programmers have their share of trouble with Hex.

The program I offer here is a BASIC version of one I wrote in COBOL several years ago. Basically, it allows the confused to “play” with Hexadecimal numbers at whatever pace is most comfortable. Coupled with independent reading on number bases and Hex in particular, it lets the concepts involved show themselves through experimentation. It’s about as painless a way as I’ve ever found to investigate and learn about Hex. It can even be fun!

I suggest that in addition to running the “Hexerciser” that the logic of the program, and especially the two conversion commands, be studied. That, plus additional reading on the subject, should eliminate any Hex “hex” that may plague you.

For those of you who will be keying this program in, let me first suggest that you take advantage of the bargain of the century and subscribe to *Rainbow on Tape*. Now, while you’re waiting for your first tape, let me save you a little trouble. The following lines are mostly cosmetic and can be ignored:

Line 40  
Lines 20000 through the end of the program

Have fun...

200	01EE
400	0435
700	06BE
1000	0986
1300	0E06
1500	1107
1800	1503
8000	18A5
17000	1C27
63005	1F4D
END	25EA

The listing:

```

10 ' HEXERCISER
20 ' COPYRIGHT (C) 1982 J.J. SCH
MIDT
30 ' ALL RIGHTS RESERVED
35 CLS
40 GOSUB20000
50 GOSUB10000
100 CLS:PRINT"      H E X A D E C
    I M A L"

```



```

110 PRINT
120 PRINT"HEXADECIMAL OR 'HEX' A
S IT IS"
130 PRINT"USUALLY CALLED IS A BA
SE 16"
140 PRINT"NUMBER SYSTEM ADOPTED
BY MOST"
150 PRINT"COMPUTER SYSTEMS AS A
HANDY WAY"
160 PRINT"TO DEAL WITH THE ARCHI
TECTURE"
170 PRINT"OF COMPUTERS THAT USE
THE 8 BIT"
180 PRINT"BYTE AS A UNIT OF STOR
AGE.":PRINT
190 PRINT"THE BYTE HAS 8 BITS.
EACH BIT"
200 PRINT"CAN HAVE A VALUE OF '0
' OR '1'"
210 PRINT"'0'='OFF' AND '1'='ON'
"
220 PRINT"          <ANY KEY>"
230 P$=INKEY$:IF P$="" THEN 230
235 SOUND234,1
240 CLS:PRINT"THE BYTE LOOKS LIK

```

```

E THIS:::PRINT
250 PRINT"POS-> 7 6 5 4 3 2
1 0"
260 PRINT"BIT-> X X X X X X
X X"
270 PRINT"VAL->128-64-32-16-8--4
--2--1"
280 PRINT"
290 PRINT"EACH X REPRESENTS A BI
T IN"
300 PRINT"THE BYTE AND THEY ARE
NUMBERED"
310 PRINT"FROM 0 TO 7 AND FROM R
IGHT TO"
320 PRINT"LEFT. BY ADDING THE V
ALUES"
330 PRINT"OF THE 'ON' BITS, IT C
AN"
360 PRINT"HOLD ANY VALUE FROM 0-
255."
370 PRINT" <ANY KEY>"
380 P$=INKEY$:IF P$="" THEN380
385 SOUND234,1
390 CLS:PRINT"HERE IS A DEMO OF
THIS."
400 PRINT"ENTER ANY VALUE FROM 0
TO 255"
410 PRINT"AND I'LL SHOW YOU HOW
IT LOOKS"
420 PRINT"IN A BYTE."
430 INPUT"(0 TO 255)";A
440 IF A<256 THEN GOSUB 8000 ELS
E GOTO 430
445 PRINT:PRINT:PRINT
550 PRINT"POS-> 7 6 5 4 3 2
1 0"
560 PRINT"BIT-> X X X X X X
X X"
570 PRINT"VAL->128-64-32-16-8--4
--2--1"
600 IF B(1)=1 THEN POKE 1318,49E
LSE POKE 1318,48
610 IF B(2)=1 THEN POKE 1321,49
ELSE POKE 1321,48
620 IF B(3)=1 THEN POKE 1324,49
ELSE POKE 1324,48
630 IF B(4)=1 THEN POKE 1327,49
ELSE POKE 1327,48
640 IF B(5)=1 THEN POKE 1330,49
ELSE POKE 1330,48
650 IF B(6)=1 THEN POKE 1333,49
ELSE POKE 1333,48
660 IF B(7)=1 THEN POKE 1336,49
ELSE POKE 1336,48
670 IF B(8)=1 THEN POKE 1339,49
ELSE POKE 1339,48
675 PRINT"AGAIN???"
680 P$=INKEY$:IF P$=""THEN680
685 IF P$<>"Y"ANDP$<>"N"THEN680
690 SOUND234,1

```

```

695 IF P$="Y"THEN390
700 CLS:PRINT"SO MUCH FOR THE BY
TE."
710 PRINT"ONWARD WITH HEX.":PRIN
T
720 PRINT"JUST AS A BYTE CAN CON
TAIN ANY"
730 PRINT"VALUE FROM 0 TO 255 (2
56 VALUES) -- DON'T FORGET 0 --"
740 PRINT"HEX NEEDS TO REPRESENT
16"
750 PRINT"VALUES, I.E. 0 TO 15."
760 PRINT"SINCE DECIMAL HAS ONLY
10"
770 PRINT"SYMBOLS FOR NUMBERS (0
-9),"
780 PRINT"HEX EXTENDED THE SYMBO
LS BY"
790 PRINT"ADDING A THRU F TO 0 T
HRU 9."
800 PRINT" <ANY KEY>"
810 P$=INKEY$:IF P$=""THEN810
815 SOUND234,1
820 CLS:PRINT"HERE ARE THE SYMBO
LS:":PRINT
830 PRINT"HEX SYMBOL-> 0 1 2
3 4"
840 PRINT"VALUE IS -> 0 1 2
3 4":PRINT
850 PRINT"HEX SYMBOL-> 5 6 7

```



## GRAND SLAM BRIDGE



SHARPEN UP YOUR BRIDGE GAME. COM-  
PUTER BIDS YOUR PARTNER'S HAND AND  
PLAYS THE OPPONENT'S HANDS. RAN-  
DOM HANDS DEALT EACH TIME. CARDS,  
TRICKS, BIDS, AND CONTRACT SHOWN  
ON SCREEN.

32K

CASSETTE \$19.95



## STOCK OPTION STRATEGIES



DEVISE YOUR OWN STOCK OPTION STRAT-  
EGIES. COVERED OPTIONS, STRADDLES,  
CALLS, AND PUTS. % GAINS AND LOSSES  
VS. FUTURE STOCK PRICES GRAPHED IN  
COLOR. EASY TO USE, NO DATA BASE RE-  
QUIRED, JUST ENTER FROM KEYBOARD.  
MENU DRIVEN.

16K

CASSETTE \$14.95



SEND CHECK OR MONEY ORDER TO:

GREENTREE SOFTWARE  
P.O. BOX 97  
GREENWOOD, IN 46142





```

8 9"
860 PRINT"VALUE IS -> 5 6 7
8 9":PRINT
870 PRINT"HEX SYMBOL-> A B
C"
880 PRINT"VALUE IS -> 10 11 1
2":PRINT
890 PRINT"HEX SYMBOL-> D E
F"
900 PRINT"VALUE IS -> 13 14 1
5":PRINT
1000 PRINT" <ANY KEY>
"
1010 P$=INKEY$:IFP$=""THEN1010
1015 SOUND234,1
1020 CLS:PRINT"JUST AS ANY OTHER
BASE"
1030 PRINT"(10 OR 2 OR??) HEX CA
N BE"
1040 PRINT"ADDED-SUBTRACTED-MULT
IPLIED"
1050 PRINT"DIVIDED OR CONVERTED
TO "
1060 PRINT"SOME OTHER NUMBER BAS
E."
1070 PRINT"USUALLY, ONLY ADD & S
UB ARE"
1080 PRINT"USED FOR MOST COMPUTE
R WORK."
1090 PRINT"HOWEVER CONVERSION IS

```

```

A MUST."
1100 PRINT"ASSEMBLERS, MONITORS
AND OTHER"
1110 PRINT"UTILITIES DISPLAY AND
USE HEX."
1120 PRINT"TWO HEX 'NUMBERS' CAN
REPRESENT"
1130 PRINT"ANY BIT COMBINATION T
HAT A BYTE"
1140 PRINT"MAY HOLD. $00 - $FF
= 0 - 255."
1150 PRINT" <ANY KEY>"
1160 P$=INKEY$:IFP$=""THEN1160
1165 SOUND234,1
1170 CLS:PRINT"HERE IS A DEMO OF
COUNTING"
1180 PRINT"IN HEX."
1182 PRINT"PRESS 'P' TO PAUSE TH
E DISPLAY"
1183 PRINT"PRESS 'R' TO RESUME"
1185 PRINT"PRESS 'X' TO EXIT"
1190 FOR I=0TO255
1200 PRINT@195,"--DEC-- ---
HEX--":PRINT
1205 B$=HEX$(I)
1210 PRINT@227," ";I
1212 PRINT@244,B$
1215 FOR II=1TO500:NEXT
1217 P$=INKEY$:IF P$="P" THEN GO
SUB 15000
1218 IF P$="X"THEN 1230
1220 NEXT
1230 CLS:PRINT"DID YOU NOTICE TH
AT WHEN"
1240 PRINT"THE RIGHT POSITION OF
THE HEX"
1250 PRINT"NUMBER REACHED 'F' TH
AT A CARRY"
1260 PRINT"OCCURRED? HEX 10, TH
E"
1270 PRINT"NUMBER AFTER HEX F, W
AS THE"
1280 PRINT"RESULT OF THE SAME CA
RRY THAT"
1290 PRINT"OCCURS IN DECIMAL FRO
M 9 TO 10."
1300 PRINT"OF COURSE HEX 10 = DE
CIMAL 16."
1310 PRINT"ADDING 1 TO HEX F (DE
C 15)"
1320 PRINT"GIVES HEX 10 (DEC 16)
.":PRINT
1330 PRINT"NOW ON TO ADD & SUBTR
ACT IN HEX.":PRINT
1340 PRINT" <ANY KEY>
">"
1350 P$=INKEY$:IFP$=""THEN1350
1355 SOUND234,1
1360 CLS:PRINT"THE BEST WAY TO L
EARN HOW"

```



**JPC PRODUCTS CO.**

## POOR MAN'S FLOPPY

### HIGH SPEED CASSETTE SYSTEM

Now for the TRS-80 Color Computer

The JPC PRODUCTS High Speed Cassette System, in operation for over 4 years, is now available for all versions of the Radio Shack® Color Computer.

- TC-8C — Plugs directly into the expansion port of your TRS-80 Color Computer. It is fully compatible with all versions of the Color Computer from the standard 4K to the Extended 32K.
  - FAST — Twice the speed of the Color Computer System.
  - RELIABLE — Less than one error in a million bits.
  - SUPPORTS TWO DRIVES — Software selectable.
  - ALL FILE TYPES — BASIC, machine language, data.
  - MOTOR CONTROL — Two on-board relays.
  - EPROM OPERATING SYSTEM
  - SPARE EPROM SOCKET — 2716 or 2732 compatible.
  - OPTIONAL JBUG MONITOR — EPROM or Cassette
    - 6809 Assembler • Memory modify and list
    - 6809 Dis-assembler • Break point traps
  - ASSEMBLED AND TESTED

TC-8C ..... \$129.95 JBUG (EPROM) ..... \$34.95  
 JBUG (Cassette)..... \$29.95

TERMS:  
 Cash, Master Card or Visa  
 Shipping & Handling \$3.50(US)  
 \$5.50 (Canada) \$15.00  
 [Foreign] Technical  
 Inquiries: Phone  
 5:00 - 6:00 PM MST



**JPC PRODUCTS CO.**  
 Phone (505) 294-4623  
 12021 Paisano Ct. NE  
 Albuquerque, NM  
 87112

COLOR COMPUTER/TDP-100\*  
**SUPER-PRO**  
REPLACEMENT KEYBOARD KIT



- Affordable Price—Only \$69.95.
- A **must have** for all serious computerists.
- Highest quality—U.S. made.
- Direct replacement—same key layout
- Professional appearance and operation.
- Fast, simple installation.
- Complete instructions included.
- In stock now.

\*Computers produced after approximately October, 1982 require an additional keyboard plug adapter—please add \$4.95.

AT YOUR FAVORITE DEALER OR DIRECT FROM



**Mark Data Products**

24001 ALICIA PKWY., NO. 226, MISSION VIEJO, CA 92691 • (714) 768-1551

We pay shipping on all orders in the continental U.S. and Canada. Overseas add \$5.00 for shipping and handling. Foreign orders please remit U.S. funds. California residents, please add 6% sales tax. We accept MasterCard and VISA. We are always looking for quality machine language programs. Contact us for details.

```

1370 PRINT"TO ADD/SUB IN HEX IS
TO WATCH"
1380 PRINT"SOMEONE WHO KNOWS HOW
- IN"
1390 PRINT"OUR CASE THAT 'SOMEON
E' IS"
1400 PRINT"THE COMPUTER. HERE I
S A DEMO"
1410 PRINT"OF ADD/SUB THAT LETS
YOU TRY"
1420 PRINT"FOR THE ANSWER BEFORE
THE"
1430 PRINT"COMPUTER ANSWERS.":PR
INT
1440 PRINT"                <ANY KEY>"
1450 P$=INKEY$:IFP$=""THEN1450
1455 SOUND234,1
1460 CLS:PRINT"ADDITION <A> OR S
UBTRACTION <S>?"
1470 AS$=INKEY$:IFAS$=""THEN1470
1475 IF AS$<>"A" AND AS$<>"S"THE
N1470
1477 SOUND234,1
1480 GOSUB16000
1482 PRINT"PRESS 'A' FOR ANSWER"
:PRINT
1490 IF AS$="A" THEN PRINT"A D D
I T I O N" ELSE PRINT"S U B T R
A C T I O N"

```

```

1495 PRINT
1500 PRINT"FIRST FACTOR--->"N1$:
PRINT
1510 PRINT"SECOND FACTOR--->"N2$
1515 PRINT"                -----
"
1517 Q$=INKEY$:IFQ$=""THEN1517
1518 IFQ$<>"A"THEN1517
1519 SOUND234,1
1520 PRINT"ANSWER IS----->"A1$
1530 PRINT"AGAIN???"
1540 Q$=INKEY$:IFQ$=""THEN1540
1550 IFQ$<>"Y" AND Q$<>"N"THEN15
40
1555 SOUND234,1
1560 IFQ$="Y"THEN 1460
1570 CLS:PRINT"HOW DID YOU DO?
IF THE"
1580 PRINT"ANSWER IS SOMETHING L
ESS THAN"
1590 PRINT"GREAT, DON'T GIVE UP!
HEX IS,"
1600 PRINT"AFTER ALL, NOT NATURA
L TO US"
1610 PRINT"WITHOUT 16 FINGERS (O
R TOES). "
1620 PRINT"THIS NEXT SECTION WIL
L HELP."
1630 PRINT"NOW WE ENTER THE BRAV

```



# OWL-WARE

→ BOOKS & PROGRAMS ←  
**ASSEMBLY LANGUAGE GRAPHICS**  
 for the TRS-80 Color Computer  
 by DON & KURT INMAN  
 280 pages \$14.95 + \$1.25 postage & handling

→ SOFTWARE 16K EXTENDED ←  
**New!!! CRYSTAL REVENGE \$16.95**  
 HI-RES Space War game. The first fully controlled  
 color in PMODE 4! You must defend the CRYSTAL HOME  
 world from the robot attackers. Planet and multicolor  
 attackers remain the same color every game.

**STARFIRE \$18.95**  
 Great machine language version of Defenders. Highly  
 rated in the Rainbow. Fast action! By Intellectronics

**Software Authors Wanted-Highest Royalties Paid**

**\$1.25 Per Order**  
**Postage & Handling**



All Orders Receive  
 10% Voucher On Order

**OWL-WARE**  
 P.O. Box 116B  
 Mertztown, PA.  
 19539  
 PA.Res. Include 6% Tax

**DEALERS INQUIRES INVITED**



# CRYSTAL REVENGE

Excellent Graphics and Sound  
 ... RAINBOW



```

E NEW "
1640 PRINT"WORLD OF CONVERSION."
1650 PRINT"WE COCO OWNERS ARE BL
ESSED"
1660 PRINT"WITH COMPUTERS THAT W
ILL DO"
1670 PRINT"CONVERSION FOR US. M
ANUAL"
1680 PRINT"CONVERSION IS A TAD D
IFFICULT"
1690 PRINT"WITHOUT CONVERSION CH
ARTS OR"
1700 PRINT"OR SOME OTHER AID."
1710 PRINT"                <ANY KEY>
"
1720 P$=INKEY$:IF P$=""THEN1720
1725 SOUND234,1
1730 CLS:PRINT"SO, IF YOU HAVEN'
T ALREADY"
1740 PRINT"DONE SO...":PRINT
1750 PRINT"MEET (FANFARE PLEASE)
:":PRINT
1760 PRINT"                HEX$(?):PR
INT
1770 PRINT"AND                &H????":PRI
NT
1780 PRINT"THE COMMAND: ? HEX$(1
234)"
1790 PRINT"WILL RETURN THE HEX V
ALUE FOR"

```

```

1800 PRINT"THE DEC NUMBER IN THE
( ).":PRINT
1810 PRINT"                <ANY KEY>
"
1820 P$=INKEY$:IFP$=""THEN1820
1825 SOUND234,1
1830 CLS:PRINT"THE COMMAND: ? &H
ABCD WILL"
1840 PRINT"RETURN THE DEC VALUE
FOR THE"
1850 PRINT"HEX NUMBER AFTER THE
'H'.":PRINT
1860 PRINT"LET'S TRY SOME CONVER
SIONS.":PRINT
1870 PRINT"<H>EX TO DEC OR <D>EC
TO HEX?"
1880 Q$=INKEY$:IF Q$=""THEN1880
1890 IF Q$<>"H" AND Q$<>"D" THEN
1880
1895 SOUND234,1
1900 IF Q$="H" THEN GOSUB 17000E
LSE GOSUB18000
1910 PRINT"AGAIN???"
1920 Q$=INKEY$:IFQ$=""THEN1920
1930 IFQ$<>"Y"ANDQ$<>"N"THEN1920
1935 SOUND234,1
1940 IFQ$="Y"THEN 1830
1950 PRINT"                <ANY KEY>
"
2000 Q$=INKEY$:IFQ$=""THEN2000

```

# WE'LL FILL YOUR MAILBOX WITH BUGS.

If your idea of a great time is staying up late wrestling with software bugs, we can supply you with all you can handle.

We're DeBug. The company that specializes in 16K Extended Basic CoCo programs that don't quite work right.

People send us programs that are driving them buggy. We pick out the most interesting ones and send them to you. With a description of where they were going. And where they went wrong. (Maybe.)

If you can fix it, we'll try to sell it. And everyone shares the profits.

Send \$9 for a sample cassette of 20 or so buggy programs. Or \$5 with a program you'd like debugged. Or \$12 for both.

**DEBUG** 114 West Central St.  
Natick, MA 01760



# CoCoDATA Enterprises

1215 Emerald Drive • Orlando, Florida 32808



All programs require 16K ECB

"Our prices are low because we are 100% mail order. . . nothing is added to accommodate retailers or distributors".

"We offer free informational flyers on each of our programs prior to purchase - just ask!"

"Satisfaction guaranteed or your money back!"

★ ★ ★ ★ ★ The Product Line ★ ★ ★ ★ ★

## GRAPHICS PROGRAM

### GENERATOR I.....\$11.95

Let your CoCo write "Syntax perfect" graphics programs for you! Boxes, circles, arcs, ellipses, paint, and lines can all be created while viewing the graphics screen using the arrow keys and a few one-key commands. Use either of four color sets in PMODE3. Extra features like "erase", "check remaining strings space" and optional grid marker pixels. When your graphics are complete, GPG I will write a unique program to tape to duplicate the picture you've created. This generated program can be edited, added to, or merged like any other! Manual details operation.

## GRAPHICS PROGRAM

### GENERATOR II.....\$16.95

All the features of GPG I plus characters with a self loading machine language module! Includes a binary screen save feature to reproduce your graphics with text in a later program. Manual includes Assembly Language source listing.

## ELECTRICITY CONSUMPTION

### MONITOR.....\$10.95

Utilize your CoCo to reduce your electric bill! Both text and graphic presentations are used to show consumption in either dollars or KWH. Extra features include bill projection anytime during month and 20 day trend analysis. If you can't measure it, you can't manage it! Sixteen page manual Includes listing and forms to record data. Printer is NOT required.



## HOUSEHOLD BUDGET

### WORKSHEET.....\$ 6.95

Produces an up-dated monthly financial worksheet without files, yet contractual loans are automatically up-dated with new balances and months remaining. Budget categories and variable expenses user defined. Includes provisions for variable income like commissions, one time expenses and/or income. Excellent manual Includes listing, examples, form to list data. Works with any printer.



## LLIST-RITE.....\$ 5.95

Complex, non-commented programs are much easier to follow after using this listing utility! Multiple statements and IF. . . THEN. . . ELSE statements are logically separated, line numbers are set apart from text, page boundaries are observed. Works with any printer; complete, easy to understand instruction sheet included.



★ ★ ★ ★ ★

Each program ordered must include 75¢ for Shipping and Handling.

COMING SOON!.. .

**Match-It!** Our version of concentration with some special surprises.

**INDIRECT FIRE!** Our computer version of the artilleryman's ancient problem of hitting a target you can't see.

```

2010 CLS:PRINT"REVIEW MENU:":PRI
NT
2020 PRINT"ENTER-":PRINT
2030 PRINT"1-ENTIRE HEXERCISER":
PRINT
2040 PRINT"2-FROM COUNTING SECTI
ON":PRINT
2050 PRINT"3-FROM ADD/SUB SECTIO
N":PRINT
2060 PRINT"4-FROM CONVERSION SEC
TION":PRINT
2070 PRINT"5-END HEXERCISER":PRI
NT
2080 PRINT"YOUR CHOICE ????"
2090 Q$=INKEY$:IF VAL(Q$) <>1 AN
D VAL(Q$)<>2 AND VAL(Q$)<>3 AND
VAL(Q$)<>4 AND VAL(Q$)<>5 THEN 2
090
2092 Q=VAL(Q$)
2100 ON Q GOTO 2110,1170,1460,18
60,2120
2105 GOTO 2100
2110 RUN
2120 END
7900 STOP
7999 STOP
8000 H=A:B(1)=0:B(2)=0:B(3)=0:B(
4)=0:B(5)=0:B(6)=0:B(7)=0:B(8)=0
9000 IF A=>128 THEN B(1)=1
9010 IF B(1)=1 THEN A=A-128
9020 IF A=>64 THEN B(2)=1
9030 IF B(2)=1 THEN A=A-64
9040 IF A=>32 THEN B(3)=1
9050 IF B(3)=1 THEN A=A-32
9060 IF A=>16 THEN B(4)=1
9070 IF B(4)=1 THEN A=A-16
9080 IF A=>8 THEN B(5)=1
9090 IF B(5)=1 THEN A=A-8
9100 IF A=>4 THEN B(6)=1
9110 IF B(6)=1 THEN A=A-4
9120 IF A=>2 THEN B(7)=1
9130 IF B(7)=1 THEN A=A-2
9140 IF A=1 THEN B(8)=1
9150 RETURN
10000 CLS:PRINT@102,"H E X E R C
I S E R"
10010 PRINT@232,"COPYRIGHT (C) 1
982"
10020 PRINT@264,"JAMES J. SCHMID
T
10030 PRINT@296,"196A ARLENE CT.
10040 PRINT@328,"WHEELING, IL. 6
0090
10050 FOR I=1TO1500:NEXT:RETURN
15000 R$=INKEY$:IF R$="R" THEN R
ETURN ELSE 15000
16000 N1=RND(32000):N2=RND(16000
)
16010 IF N1<N2 THEN S1=N1:N1=N2:
N2=S1:S1=0

```



# ENDICOTT SOFTWARE

## JOYSTICKS

DEALER & CLUB INQUIRIES INVITED

COME SEE US  
AT THE  
**RAINBOWfest**  
IN CHICAGO  
APRIL 22, 23, & 24

**AFFORDABLE**

**ONLY  
\$19.95**

**TWO FOR  
\$37.95**

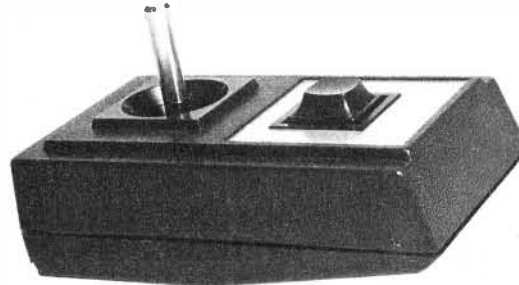

**80 MICRO  
REVIEWED  
MARCH 1983**

**ACCURATE**

**SMOOTH  
RESPONSE**

**BUILT TO  
LAST**

Tired of broken joysticks? We offer an affordable joystick based on proven components. Each unit is hand assembled and checked to ensure **reliability**. The handles and internal mechanism have proven to be extremely **rugged** and reliable under extensive use with arcade-type games. The pots function smoothly to provide excellent cursor/character control. Get your joystick programs working the way they **should!** Our joysticks are backed by a 90 day warranty on material and labor.

### EXCELLENT PROGRAMS FROM LEADING SOFTWARE HOUSES

#### NEW DISCOUNT ON PRICKLY-PEAR SOFTWARE! 20% OFF UNTIL MAY 7

* <b>VIKING</b> Go from peasant to King!	<del>\$19.95</del>	\$15.96	
* <b>GANGBUSTERS</b> Lead a life of crime and win!	<del>\$19.95</del>	\$15.96	
<b>PANDORA'S BOX</b> Includes: "pac" game, "defender-type" game, Divebomb, Blockade, slot machine, and Squares (like cube).	<del>\$24.95</del>	\$19.96	
* <b>PREREAD I, II, &amp; III</b> (Three tapes) Prepare your preschooler to learn to read	<del>\$24.95</del>	\$19.96	
* <b>PHONICS I</b> 1 tutorial tape, 1 quiz tape. These begin the learning to read process.	<del>\$24.95</del>	\$19.96	
* <b>PHONICS II</b> Advancement from PHONICS I	<del>\$24.95</del>	\$19.96	

#### MARK DATA PRODUCTS

<b>SPACE RAIDERS</b> Not just another Invaders game.	\$24.95	
<b>CAVE HUNTER</b> Grab the treasure and outrun the creatures.	\$24.95	
<b>HAYWIRE</b> Will drive you <b>BERZERK!</b>	\$24.95	

#### TOM MIX SOFTWARE

* <b>ESCAPE FROM SPECTRE</b> Graphic Spy Adv.	\$17.95	
* <b>KATERPILLAR ATTACK</b> Look out for spiders!	\$21.95	
* <b>MOON LANDER</b> 2 games in 1	\$17.95	
* <b>CASINO</b> 3-Gambling Package	\$12.95	
<b>TAPE DUPE</b> Copies any ML tape.	\$16.95	
<b>DISK TO TAPE</b> Dump most disks to tape	\$17.95	
<b>TAPE TO DISK</b> Load most tapes to disk	\$17.95	
* <b>SPELLING TEST</b> Provides a standard oral spelling quiz. Optional printer output.	\$19.95	

#### ★ ★ 32 Korner ★ ★ (Requires 32K Ext. Basic)

TOM MIX'S <b>SPACE SHUTTLE</b> Control the Space Shuttle	\$28.95	
<b>DONKEY KING</b> 4 Screens - Full action!	\$26.95	
<b>PROTECTORS</b> Excellent Defender type.	\$24.95	
<b>COLOR GOLF</b> Challenging! Uses full set of clubs.	\$17.95	
PRICKLY-PEAR'S <b>FLIGHT</b> Realistic flight simulator	<del>\$19.95</del>	\$15.96
<b>8-BIT BARTENDER</b> Party fun. 100+ recipes.	<del>\$19.95</del>	\$15.96

#### 15% OFF UNTIL MAY 7

##### ANTECO SOFTWARE

<b>INTERGALACTIC FORCE</b> Experience trench warfare in your X-Wing fighter.	<del>\$24.95</del>	\$21.20	
* <b>HOUSEHOLD EXPENSE MANAGER</b> Menu-driven with 30 household categories. Screen or printer output.	<del>\$19.95</del>	\$16.95	
* <b>STOCK ANALYZER AND TREND</b> Track your stocks. Disk compatible. Optional printer output.	<del>\$21.95</del>	\$18.65	

##### COGNITEC

<b>TELEWRITER 64</b> (For 16, 32, or 64K) THE word processor for the CoCo	<del>\$49.95</del>	\$42.45	
--	--------------------	---------	--

##### PETROCCI FREELANCE ASSOCIATES

<b>INSPECTOR CLUESEAU</b> (32K ext.) Find the murderer in this excellent graphic adaptation of Clue.	<del>\$19.95</del>	\$16.95	
---	--------------------	---------	--

##### COLORSOFT

* <b>MATH DERBY</b> Fun while learning!	<del>\$13.95</del>	\$11.86	
---	--------------------	---------	--

##### COMPUTERWARE

<b>MEGAPEDE</b> Most challenging version yet.	\$21.95	
<b>SHARK TREASURE</b> Don't get eaten!	\$21.95	
<b>SPACE AMBUSH</b> Action like Galaxian.	\$21.95	
<b>DOODLE BUG</b> Like Ladybug	\$24.95	
<b>RAIL RUNNER</b> Dodge trains and handcars	\$21.95	
<b>PAC ATTACK II</b> Great gobbler. New graphics.	\$24.95	
<b>STORM</b> A real Tempest!	\$24.95	
<b>COLOR INVADERS</b> Like the original.	\$19.95	

\* Requires 16K Ext. Basic minimum - others 16K Std. Basic minimum.

ADDITIONAL LISTINGS IN OUR FREE CATALOG. CALL OR WRITE.

SHIPPING: U.S.A., CANADA AND MEXICO

WE PAY POSTAGE on all software orders. Add \$2.00 for shipping joysticks (unless purchased with software - then we'll pay). Please add \$2.00 for C.O.D. orders (available in U.S.A. only). Allow 2 weeks for personal checks to clear.

SHIPPING: ALL OTHER COUNTRIES

Add \$2.00 for each software item. Add \$3.00 for each Joystick. Items will be shipped air mail.

ALL PAYMENTS MUST BE IN U.S. FUNDS.

### ENDICOTT SOFTWARE

P.O. Box 12543, Huntsville, AL 35802

VISA

(205) 881-0506

PHONE OPEN 7 DAYS A WEEK!





```

16015 IF AS$="S"THEN16030
16020 N1$=HEX$(N1):N2$=HEX$(N2):
A1$=HEX$(N1+N2)
16025 GOTO16040
16030 N1$=HEX$(N1):N2$=HEX$(N2)
A1$=HEX$(N1-N2)
16040 IF LEN(N1$)<4 THEN N1$=STR
ING$(4-LEN(N1$),"0")+N1$
16050 IFLEN(N2$)<4 THEN N2$=STRI
NG$(4-LEN(N2$),"0")+N2$
16060 IFLEN(A1$)<4 THEN A1$=STRI
NG$(4-LEN(A1$),"0")+A1$
16070 RETURN
17000 INPUT"ENTER HEX NUMBER";H$

```

```

17010 HH$="&H"+H$
17020 PRINT"ANSWER->";VAL(HH$)
17030 RETURN
18000 INPUT"ENTER DEC NUMBER";D
18010 DD$=HEX$(D)
18020 PRINT"ANSWER->";DD$
18030 RETURN
20000 'ENTRY POINT FOR SCREEN
63001 DATA159,159,023,008,001,02
0,159,020,008,005,159,159,159,15
9,159,159,159,159,159,159,159,15
9,159,159,159,159,159,159,159,15
9,159,159
63002 DATA159,159,159,159,159,15
9,159,159,159,159,159,159,159,15

```

```

9,159,159,159,159,159,159,159,15
9,159,159,159,159,159,159,159,15
9,159,159
63003 DATA159,159,159,159,159,15
9,159,159,255,159,159,255,159,25
5,255,255,255,159,255,159,159,15
9,255,159,159,159,159,159,159,15
9,159,159
63004 DATA159,159,159,159,159,15
9,159,159,255,159,159,255,159,25
5,159,159,159,159,159,255,159,25
5,159,159,159,159,159,159,159,15
9,159,159
63005 DATA159,159,159,159,159,15
9,159,159,255,255,255,255,159,25
5,255,255,159,159,159,159,255,15
9,159,159,159,159,159,159,159,15
9,159,159
63006 DATA159,159,159,159,159,15
9,159,159,255,159,159,255,159,25
5,159,159,159,159,159,255,159,25
5,159,159,159,159,159,159,159,15
9,159,159
63007 DATA159,159,159,159,159,15
9,159,159,255,159,159,255,159,25
5,255,255,255,159,255,159,159,15
9,255,159,159,159,159,159,159,15
9,159,159
63008 DATA159,159,159,159,159,15
9,159,159,159,159,159,159,159,15

```

## YOUR COLOR COMPUTER JUST EARNED A MATH DEGREE!

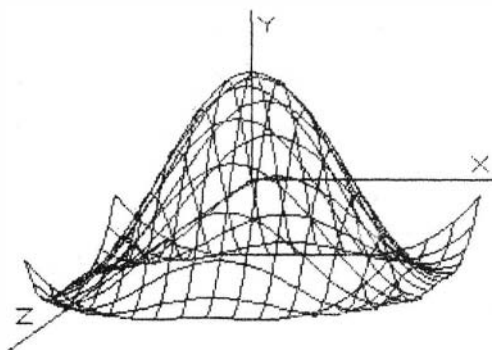

### MATHMENU

Developed by an engineer, *Mathmenu* is a powerful menu-driven system to turn your Color Computer into an intelligent, flexible tool for mathematics and engineering. *Mathmenu* takes the tedium out of math, leaving your full brain power to attack the "meat" of your problems. By rapidly manipulating matrices and vectors, performing integration and differentiation, solving quadratic equations, plotting user defined functions and much more, *Mathmenu* can help simplify the most complex problems. Whether you are a student or a professional, if you use math, you need *Mathmenu*.

#### FEATURING:

- 3D SURFACE PLOTTING — Plots a user defined equation on an X,Y,Z coordinate system in the High-Res graphics mode. Planes, surfaces of revolution, statistical surfaces, etc. can be easily plotted. Surfaces may be saved to disk or tape. We believe this is the only program of its kind commercially available for the Color Computer.

#### PLUS:

- Complete MATRIX Operations (up to 8 x 8)
- Complete VECTOR Operations
- Numerical Differentiation
- Numerical Integration
- Least Squares Curve Fitting
- Binomial Expansion
- Prime Number Verification
- Main Menu with Single-key Selection and Return (Disk Only)
- 2D Function Plotting
- Rectangular to Polar Conversions
- Base Conversions
- Large Number Addition and Multiplication
- Reverse Polish Logic Calculator with Hexadecimal
- Quadratic Equation Roots

Complete documentation of all functions is included.

For 32K Disk ..... \$49.95  
 For 16K Cassette ..... \$44.95  
 Documentation only ..... \$2.00 (refundable with purchase)

Or write for free brochure.



Inter  Action

113 Ward Street • Dept. R • New Haven, CT 06519 • (203) 562-5748

9, 159, 159, 159, 159, 159, 159, 159, 15  
 9, 159, 159, 159, 159, 159, 159, 159, 15  
 9, 159, 159  
 63009 DATA159, 159, 159, 159, 159, 15  
 9, 159, 159, 159, 159, 159, 159, 159, 15  
 9, 159, 159, 159, 159, 159, 159, 159, 15  
 9, 159, 159, 159, 159, 159, 159, 159, 15  
 9, 159, 159  
 63010 DATA159, 159, 159, 159, 159, 15  
 9, 159, 159, 159, 159, 159, 159, 159, 15  
 9, 009, 019, 159, 159, 159, 159, 159, 15  
 9, 159, 159, 159, 159, 159, 159, 159, 15  
 9, 159, 159  
 63011 DATA159, 159, 159, 159, 159, 15  
 9, 159, 159, 159, 159, 159, 159, 159, 15  
 9, 159, 159, 159, 159, 159, 159, 159, 15  
 9, 159, 159, 159, 159, 159, 159, 159, 15  
 9, 159, 159  
 63012 DATA159, 159, 159, 159, 159, 15  
 9, 159, 159, 159, 159, 159, 159, 159, 15  
 9, 159, 159, 159, 159, 159, 159, 159, 15  
 9, 159, 159, 159, 159, 159, 159, 159, 15  
 9, 159, 159  
 63013 DATA159, 159, 159, 159, 159, 00  
 8, 159, 005, 159, 024, 159, 001, 159, 00  
 4, 159, 005, 159, 003, 159, 009, 159, 01  
 3, 159, 001, 159, 012, 159, 159, 159, 15  
 9, 159, 159  
 63014 DATA159, 159, 159, 159, 159, 15  
 9, 159, 159, 159, 159, 159, 159, 159, 15  
 9, 159, 159, 159, 159, 159, 159, 159, 15  
 9, 159, 159, 159, 159, 159, 159, 159, 15  
 9, 159, 159  
 63015 DATA159, 159, 159, 159, 159, 15  
 9, 063, 159, 063, 159, 063, 159, 063, 15  
 9, 063, 159, 063, 159, 063, 159, 063, 15  
 9, 063, 159, 063, 159, 159, 159, 159, 15  
 9, 159, 159  
 63016 DATA159, 159, 159, 159, 159, 15  
 9, 159, 159, 159, 159, 159, 159, 159, 15  
 9, 159, 159, 159, 159, 159, 159, 159, 15  
 9, 159, 159, 159, 159, 159, 159, 159, 15  
 9, 159, 159  
 63017 PS=1:L=1:BB=1024:EB=1055  
 63018 FOR OL=1T016  
 63019 FOR IL=BB TO EB  
 63020 READ BY\*  
 63021 POKEIL, VAL (BY\*)  
 63022 PS=PS+3  
 63023 NEXT  
 63024 EB=EB+32:BB=BB+32:PS=1:L=L  
 +1  
 63025 NEXT  
 63026 PLAY"V20"  
 63028 FORX=1T020  
 63029 PLAY "L255;A;P55;A;P55;A;P  
 55;A;P55;A;P55;A;A;A;V-"  
 63031 NEXT  
 63032 RETURN



★ ★ ★ **SELECTED SOFTWARE** ★ ★ ★

FOR THE COLOR COMPUTER

All programs are in 16K machine language unless noted. Extended basic not required.

**MARK DATA PRODUCTS**

- \*\* **SPACE RAIDERS** New Invader-type game. Super Hi-Res Graphics and Sound. You'll love it. **\$24.95**
- \* **ASTRO BLAST** Excellent space shooting game. Super Hi-Res Graphics and Sound. **\$24.95**
- \* **COLOR HAYWIRE** Classic arcade game, rated A+ by Color Computer magazines. **\$24.95**

**SPECTRAL ASSOCIATES**

- \* **GALAX ATTAX** Protect your base by shooting alien fighter in formation. Excellent Graphics and Sound. **\$21.95**
- \*\* **SPACE RACE** Maneuver yourself in space but alien ships appear and must be destroyed. Hi-Res Graphics and Sound. **\$21.95**
- \* **PLANET INVASION** Excellent Defender-type game. Highest-Res Graphics and Sound. **\$21.95**
- " **DEFENSE** Defend your spaceships from enemy laser beams. **\$21.95**
- \* **SPACE WAR** You must break through the enemy fighters and the defenses of Death Star. Super fast. **\$21.95**
- \*\* **SPACE INVADERS** Fast action Invader game. Excellent Graphics and Sound. **\$21.95**
- \* **GHOST GOBBLER** Highly rated Pac Man-type game. 16 skill levels and lots of action. **\$19.95**
- KEYS OF THE WIZARD** Super adventure game! Great sound! You never play the same twice. **\$19.95**
- MADNESS AND THE MINOTAUR** Challenging adventure game, different everytime. **\$19.95**

**TOM MIX SOFTWARE**

- \* **DONKEY KING** (32K) Just Outstanding! **\$24.95**
- \* **KATERPILLAR** Excellent Centipede-type game. Highly rated by Color Computer magazines! **\$24.95**
- \* **WAR KINGS** Battle to save your castle and king. Hi-Res Graphics with Outstanding Sound. **\$19.95**
- \* **PROTECTORS** (32K) Excellent Graphics and Sound. **\$24.95**

**MED SYSTEMS**

- INVADER'S REVENGE** You are the last survived space invader. You must revenge! **\$19.95**
- PHANTOM SLAYER** Enter the deadly catacombs and destroy the phantoms, 3-D Graphics. **\$19.95**

**INTELLECTRONICS**

- \* **DUNKEY MUNKEY** (32K) Absolutely excellent Donkey Kong-type game. You'll love it! **\$21.95**
- STAR FIRE** One of the best Defender-type game. Hi-Res Graphics and Sound. **\$19.95**

**INTRACOLOR**

- \*\* **COLORPEDE** Just like the arcade. **\$29.95**

**THE PROGRAMMER'S GUILD**

- \*\* **PACDROIDS** The most challenging Pac Man-type. Super Hi-Res Graphics and Sound. **\$19.95**

**CHROMATIC SOFTWARE**

- \* **THE SPIDER** Travel the channels destroying the spiders before they get you. Super action. Excellent Graphics and Sound. **\$19.95**

**UPGRADE YOUR COLOR COMPUTER!**

Complete solderless kits with easy-to-follow instructions.

**4K-16K** \$15.95  
**16K-32K** \$29.95

*Introductory Offer Ends Soon! Price Will Increase Next Month!*

**64K CHIP SET**

Eight 4164-200 NS Prime ICs **\$54.95**

\*Requires Joystick \*\*Joystick Optional

Write for complete listings. Buy 2 items and get 10% off. We pay postage on all orders. Send check or money order to:

**SELECTED SOFTWARE**  
 P.O. Box 32228, Fridley, MN 55421  
 (MN Residents add 6% sales tax.)

## Three Easy Pieces: One Animator's Art

By Stephen Lai

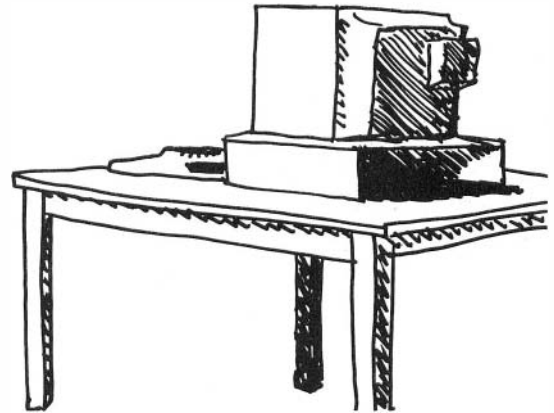

Once I had learned the art of animation, which on my part took much more effort than simply reading the material included about it in the CoCo manuals, I wondered how I could apply it to produce beautiful moving graphics. My father came up with the idea of using the *SIN/COS* functions which, as you will see, solved the question asked above.\*

In these three programs, I use the command *PMODE 1*, which allows for the maximum use of four graphic pages on the 16K CoCo. All three programs have X number of lines, curves or leaves protruding from the midpoint of the screen. To find the number of degrees a figure rotates at every flip of a page, use this formula:  $360 / (\text{number of lines, leaves, or curves} \times 4)$ .

When a program is typed in and *RUN*, the computer prompts you with the question, "ARE THE PAGES DRAWN?" (Y/N). If they are drawn, only input "Y" if you want to see the same display again. Next, you are asked for the number (#) of lines or leaves.

The two processes these programs consist of are the drawing process and the display process. The drawing process goes through the four pages, one by one, producing a figure differing from the figures on the other pages by a number of angles. This process varies in time taken according to the number of lines, leaves or curves and the specific program. After that lengthy process is finished, the real impressive stuff flashes across the screen, but not before you *INPUT* a delay speed.

Enough for the general; now for the specifics.

*Revolver* is the most basic of all three programs. The display is similar to the spokes of a wheel. A good first input would be 15 for the number of lines and 20 for delay speed. *Twirlers* is the most fancy and impressive of the programs. The leaves are of random width and color. Four mini-twirlers are at the corners of the screen. The drawing process is very lengthy, so have a magazine ready to flip through while the program gets ready to do its flipping. A sound will inform you that the drawing process is done. During the display process, you can cause the figures to rotate in the opposite direction by pressing the letter "C." A good starting input would be 3 for number of leaves and 30 for rotating speed.

*Spinner* needs no inputs for number of curves or rotating speed. There are always four curves and the rotating speed changes throughout the display process getting faster to a certain point, then slower to a certain point, then faster, slower, etc.

The three programs use the *POKE 65495,0* and *POKE 65494,0* commands, which must be deleted to be run on some older CoCos.

\* Editor's note: For an in-depth discussion of the technique, using sine/cosine functions, refer to Don Inman's *Using Graphics* column in the March 1983 issue of *Rainbow*.

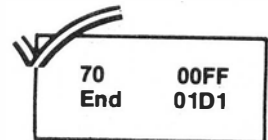

The listing:

```

1  >          REVOLVE
2  >          BY STEPHEN LAI
3  >          (C) 1982
10 CLS:INPUT"ARE PAGES DRAWN (Y/
N)";Z$:IFZ$="N"THENGOTO150ELSEGO
TO130
20 INPUT"NUMBER OF LINES";N:PMOD
E1,1:PCLS:SCREEN1,0
30 PI=3.14159
40 POKE65495,0
50 FORP=0TO3:PMODE1,(P+1)*2-1:PC
LS:SCREEN1,0
60 B=P*PI/(N*2)
70 FORL=1TON
80 X=-25*PI
90 Y=SIN(X/25)
100 R=SQR(X^2+Y^2):AA=ATN(Y/X)+B
:H=R*COS(AA):V=R*SIN(AA)
110 LINE(126,96)-(H+126,V+96),PS
ET
120 B=B+2*PI/N:NEXTL,P
130 INPUT"DELAY SPEED";S
140 FORP=1TO7STEP2:PMODE1,P:SCRE

```

# TAKE A CLOSER LOOK THERE'S SOMETHING For EVERYONE

## SOFTWARE

### DONKEY KING

by Tom Mix Software

Four full graphic screens. Exciting sound and realistic graphics. Never before has the color computer seen a game like this.

Tape ..... **\$24.95**  
Disc ..... **\$27.95**

### SKY-DEFENSE

Can you survive the first wave of attack? Or the next? Or the next? Only your joystick will ever know! Features horizontal flight in highres graphics, and fast-paced action. Machine language; joystick required. 16K. .... **\$12.95**

### BIGNUM

If you dislike seeing numbers like 1.23045 E 23, and wish you could have **all** the accurate digits instead, then BIGNUM is for you. Add, subtract, multiply, divide and raise BIG numbers to BIG powers and get totally accurate results. Even if you are satisfied with an approximation, without this program the Color Computer would return an "OV ERROR" with this problem: 34↑45. BIGNUM returns the entire 68 digit result! Accurate to 1,024 digits in 16K & about 3,068 digits with 32 RAM. 16K. .... **\$9.95**

### CCM#3

by Charles Santee, Ed.D.

This program allows total communication for special persons and does this with only one joystick. Easy to use, and also recommended for young children; can help teach spelling and sentence structure. Excellent documentation.

32K EXT ..... **\$32.95**

## HARDWARE

### 16K-32K UPGRADE KIT

Kit includes 8 200 ns #4116 Factory Prime Chips, piggybacked sockets, SAM socket, and "32K" button to replace the 16K on your computer's case. Easy to remove. No soldering to computer. .... **\$25.95**

### 64K RAM CHIPS

200 ns #4164 chip set will upgrade your "E" board easily. Factory Prime Chips. (Compare the price elsewhere!). **\$69.95**

### Nanos Reference Cards

Color Computer & TDP-100  
Color BASIC & EXTENDED ..... 4.95

### DATA CASSETTES

	CO5		C10	
\$ .65	..... Qty.	1-10	.....	\$ .70
\$ .60	..... Qty.	11-20	.....	\$ .65
Soft Poly Cases	.....	Ea.		\$ .20

### AUX-KEY

by JARB

(Auxiliary External Keyboard Unit)  
This full size, industrial grade keyboard unit is P.C. board mounted for trouble free operation and years of use. Mounted in an attractive aluminum case with a 19-key numeric pad, AUX-KEY comes with long cable for remote placement of your 80C. No soldering required for installation. Will not affect normal operation of the original keyboard. .... **\$134.95**

Add \$1.50 per software order and \$2.00 per hardware order for postage and handling.

California residents add 6% Sales Tax.

## QUASAR ANIMATIONS

1520 Pacific Beach Drive, San Diego, California 92109  
(619) 274-2202



```
EN1,0:FORDLAY=1TOS:NEXTDLAY,P:GO
TO140
150 PCLEAR8:GOTO20
```

110	01B7
End	0356

```
1  ' TWIRLERS
2  ' BY STEPHEN LAI
3  ' (C) 1982
10 CLS:INPUT"ARE PAGES DRAWN (Y/
N)";Z$:IFZ$="N"THENGOTO240ELSEGO
TO160
20 INPUT"NUMBER OF LEAVES";N:PMO
DE1,1:PCLS:SCREEN1,0
30 C1=RND(3)+1:C2=RND(3)+1:C3=RN
D(3)+1:C4=RND(3)+1:C5=RND(3)+1:E
=1+RND(20)*.1
40 PI=3.14159
50 POKE65495,0
60 FORP=0TO3:PMODE1,(P+1)*2-1:CO
LORC2,1:PCLS:SCREEN1,0
70 B=P*PI/(N*2)
80 FORL=1TON
90 FORX=-25*PI TO25*PI STEP2
100 D=X/E:Y=D*SIN(X/25)
```

```
110 R=SQR(X^2+Y^2):AA=ATN(Y/X)+B
:H=R*COS(AA):V=R*SIN(AA)
120 IFX=-25*PI THENGOSUB190
130 PSET(H+126,V+96,C1):NEXT
140 B=B+2*PI/N:NEXTL,P
150 SOUND1,40
160 INPUT"DELAY SPEED";S
170 FORP=1TO7STEP2:PMODE1,P:SCRE
EN1,0:FORDLAY=1TOS:IFINKEY$="C"
HEN180ELSENEXTDLAY,P:GOTO170
180 FORP=7TO1STEP-2:PMODE1,P:SCR
EEN1,0:FORDLAY=1TOS:IFINKEY$="C"
THEN170ELSENEXTDLAY,P:GOTO180
190 CIRCLE(H/4+208,V/4+150),10,C
3
200 LINE(48+(-H/3.5)-4,150+(V/3.
5)-4)-(48+(-H/3.5)+4,150+(V/3.5)
+4),PSET,BF
210 CIRCLE(-H/6+48,V/6+24),2,C4:
CIRCLE(H/4+48,V/4+24),2,C5
220 LINE(208,24)-(208-H/4,24+V/4
),PSET
230 RETURN
240 PCLEAR8:GOTO20
```

70	0109
End	0219

**BATTLE of GETTYSBURG**  
**A Strategy Game**  
**for mature Players**

**STOP REBEL INVADERS**  
**OR DIE!**

16K ext.  
joystick

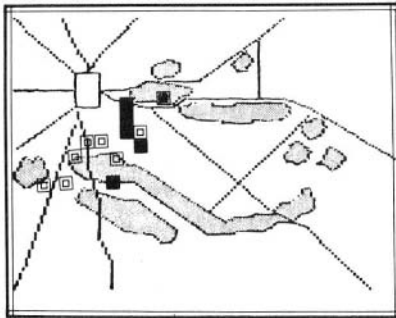

cassette  
\$20.95

**SOFTWRIDE**

P.O. Box 3504  
Austin, Texas: 78764  
(512)-444-6135

```
1  ' SPINNER
2  ' BY STEPHEN LAI
3  ' (C) 1982
10 GOTO170
20 N=0:L=75:C=RND(3)+1:D=RND(40)
+10:PI=3.14159
30 CLS:INPUT"ARE PAGES DRAWN (Y/
N)";Q$:IFQ$="N"THEN40ELSEGOTO110
40 F=1:FORN=1TO7STEP2:PMODE1,N:
SCREEN1,0:PCLS
45 POKE65495,0
50 FORX=-25*PI TO0STEP2
70 X1=X/25:Y=D*SIN(X1)
80 R=SQR(X^2+Y^2):A=ATN(Y/X):B=A
+N*(PI/16):H=R*SIN(B):V=R*COS(B)
90 PSET(V+126,-H+96,C):PSET(-H+1
26,-V+96,C):PSET(H+126,V+96,C):P
SET(-V+126,H+96,C)
100 NEXTX,N
110 I=-2:L=50
120 FOR A=7TO1STEP-2:PMODE1,A:SC
REEN1,0
130 SOUND 225-4*L,1
140 FOR DLAY=1 TO L:NEXT DLAY,A
150 L=L+I:IFL<50RL>50THENI=-I
160 GOTO120
170 PCLEAR8:GOTO20
```

# JARB I N C SOFTWARE HARDWARE

## COMPUTER PRODUCTS

### AUX-KEY

*(Auxiliary External Key Board Unit)*

This full size, industrial grade key board unit is P.C. Board mounted for trouble free operation and years of use. Mounted in an attractive aluminum case with a 12 key numeric pad, Aux-Key comes with a long cable for remote location placement of your 80C. Requires no soldering to your computer, and only about 15 minutes for installation. Does not affect normal operation of your original key board.

Add \$4.00 Shipping ..... \$134.95

### PEN-E-ARCADE

*(Light Pen & Arcade System)*

This unique system will allow the light pen (included) to be used with supplied software for many tasks normally requiring key board input. In education, choose answers by just touching pen to correct screen location. Can be easily interfaced to your own programs. All instructions supplied. Also includes the JARB arcade target gun and target software. Shoot targets from across the room. No other unit like this is presently available from anywhere else for the 80C or TDP-100 computers.

Add \$4.00 Shipping ..... \$74.95

### COMREX CR-6500

*(13" Color Monitor)*

High resolution display monitor produces an incredibly sharp image. Includes built-in speaker with audio circuit. Compatible with virtually any microcomputer.

..... \$344.95

### COMREX CR-1

Compact desk-top daisy wheel printer, especially designed for word processing. Assures high reliability, and produces quiet, high quality printing. Complete with RS-232 interface.

..... \$810.00

U.S FUNDS ONLY

C.O.D. ORDERS ACCEPTED

Sorry, no C.O.D. on printers and monitors.

NO CREDIT CARD ORDERS

### \*VIDEO INTERFACE KIT

Allows the composite video signal to be interfaced directly to a B/W or color monitor. TV and monitor can be used simultaneously. Complete with comprehensive instructions and all parts, including an external sound output. NOTE: May not work with monitors requiring high input drive - call or write for recommended monitors.

..... \$19.95



### DUAL JOYSTICK UNIT (D.J.)

Single unit assembly enhances playability of multi-joystick/player games; convenient press-to-fire buttons

Add \$4.00 shipping ..... \$35.95

### EPSON PRINTERS

MX80FT/Graftrax + ..... \$524.95

MX100FT/Graftrax + ..... \$699.95

Serial Interface w/4K Buffer

Ideal for 80C use ..... \$109.95

80CTO Epson Cable ..... \$19.95

See shipping Info

### NEW PRICES ON DATA CASSETTES

C-05 C-10

\$ .65 ..... QTY 1-10..... \$ .70

\$ .60 ..... QTY 11-20..... \$ .65

Soft Poly Cases ..... Ea. \$.20

Hard Shelled Cases ..... Ea. \$.22

Cassette Labels (12) ..... Sh. \$.36

Cassette Labels Tractor (1000) .... \$30.00

Call or write for quantity prices on all cassette products. Special lengths available, eg., C-02, etc.

### NANOS COLOR BASIC AND EXTENDED SYSTEM REFERENCE CARD

"The New Industry Standard"  
\$4.95

*(We pay postage on this one)*

All types of Nanos cards available

### MEMORY UPGRADE KITS

#### \*4K/16K MEMORY CHIP SET

Eight 200 NS 4116 Factory Prime Chips, 16K Ram Button, and Upgrade Instructions. No Soldering.

..... \$16.95

#### \*16K/32K MEMORY UPGRADE KIT

Eight 200 NS 4116 Factory Prime Chips with Piggy Backed Sockets, Sam Socket, Bus Wire, and 32K Ram Button. Comprehensive Instructions. Recommended for "D" or earlier, but may be used on "E". Only 9 simple solder connections to kit. None to computer.

..... \$25.95

#### \*64K RAM CHIPS

Eight 200 NS Factory Prime 64K RAM Chips. Allows you to upgrade "E" board easily. No soldering needed.

..... \$69.95

\*Installation of these items will void the Radio Shack warranty. Radio Shack is a trademark of the Tandy Corp.

### WABASH DISKETTES

\$25.00 per box of 10

### DISK DOUBLER

\$12.95

### CoCo Chips

Sam, Pia, CPU, Ext. Basic, and 1.1 Standard Available

*We carry products from many manufacturers. If you don't see it, ask.*

# JARB I N C SOFTWARE HARDWARE

1636 D Avenue, Suite C  
National City, CA 92050  
(619) 474-6213

SHIPPING AND HANDLING: Printers and monitors add 3%. Unless otherwise specified, all other orders \$2.00 per order. California Residents add 6% sales tax.

## Preschool Packs: Simple, Solid, Successful

Preschool Packages 1, 2, and 3, from Computer Island, are designed to teach kids in a fun and simple game format. Some of the programs in this collection are more successful at this than others.

### PRESCHOOL PACK 1, CLOWN AND FISH NUM

In *Clown*, a face appears under one of five triangles. The child counts across to find the number of the triangle and then presses the number on the keyboard. If incorrect, a sad sound is heard and the child then has a chance to try again. When correct, a happy sound is heard and then a new "problem" is set-up. Number recognition and counting skills are reinforced by the use of this program.

In *Fish Num*, a random number of fish (1-10) appear on the screen with the spelling of the number of fish above the display. The child figures out how many fish are on the screen, (by word recognition or by counting), and presses the corresponding number on the keyboard. If wrong, you hear the sad sound. A correct answer receives a happy sound and spells out the correct answer. This program reinforces number recognition and counting skills and introduces spelling.

The games, sounds, and graphics are all very simple in package number 1.

### PRESCHOOL PACK 2, COUNT KIDS AND ADD PENNY

In *Count Kids*, a random number of kids' faces appear on the screen. The child counts the kids and presses the corresponding number. A wrong answer receives a sad sound, a correct answer a happy sound. Of the whole group, this program has the most interesting graphics and is the most entertaining for children. With this program, counting scattered objects as well as number recognition are reinforced.

*Add Penny* draws large pictures of pennies in two rows. This is set up in the same format in which beginning addition

is presented in school. The child counts the pennies and presses the corresponding key. Once again, wrong answers receive a sad sound, correct answers receive a happy tune. This program reinforces counting and number recognition and sets the stage for teaching addition in the future.

*PACKAGE 2* has the best graphics and sounds of the group.

### PRESCHOOL PACK 3, ALPHA-BYTE

*Alpha-byte* consists of three programs, each covering a portion of the alphabet, to help preschoolers recognize the letters of the alphabet. All three are played in the same way. The letters covered by the particular program are displayed on the screen. The program then draws one of the letters again under the corresponding letter already displayed. The child then presses the appropriate key that matches the letter. The usual sad and happy sounds accompany wrong and correct answers. The child need not know the alphabet in order to play, but can just match shapes and symbols.

This third package is less interesting, both in play and in graphics.

All the programs in these three packages are easy for small children to play on their own without adult help. All answers are single key inputs, meaning that you don't use the *ENTER* key. There is no time limit on any of these games. Children may play for as long as they wish, using the *BREAK* key to end the program when done. However, there is also no score or identification of which problems the child has trouble with.

Of the three packages, pack 2 is definitely the best. It is the most interesting for small children to play and has the most appealing graphics. All are in 16K ECB.

These games lack the "extras," but are perhaps more suitable for preschoolers because of it. They are all simple and unsophisticated games at a good price.

(Computer Island, Dept. R, 227 Hampton Green, Staten Island, NY 10312, Preschool Packs 1, 2, 3 @ \$11.95)

— James Ventling

ACS

Post Office Box 15235  
Plantation, Florida  
33318

All Color Software

---

**New! from ACS . . .**

Give your CoCo an  
On/Off light for \$5.00!!  
Will NOT Void Warranty!



Now for only \$5 you can have an on/off light for your CoCo, without voiding your warranty!! If you own a joystick, can drill ONE hole, and make TWO connections, then you are ready for this simple Do-It-Yourself Kit!!

This simple kit comes with the parts to modify 2 joysticks, and clearly written instructions on the procedure, which takes only 10 minutes on the average.

Note! This modification Does NOT impede joystick performance. This kit works with any joystick, and is equally easy to install in each.

**ORDER NOW!!**

**NO Extra Shipping Charges!!**

Florida residents add 5% sales tax. Note! Custom joysticks still available.



# DSL COMPUTER PRODUCTS

P.O. BOX 1113 - DEARBORN, MI 48121 - (313) 582-8930



**Michigan Residents Add 4% Sales Tax to Order  
Please include \$1.00 for S & H  
VISA & MASTERCARDS ACCEPTED**

## QUALITY SOFTWARE FOR THE COLOR AND TDP SYSTEM 100 COMPUTERS

### Specialty

The General a general ledger program holds 100 accounts with over 500 transactions per account 32K \$39.95

Calligrapher Great for designing custom posters, invitations flyers or name tags Two print fonts available Old English and Chancery for Line Printer VII use Disk ONLY \$14.95 each Please specify print font when ordering.

Color Bonanza 50 program package includes business, utilities, utilities as well as arcade fun. Less than \$1.00 per program! \$49.95

### Arcade Fun

Packmaze	ML	16K	\$16.95
Bug Chase Ext.	32K		\$15.55
One or two player or robot bug against turtle.			
Donkey King	32K		\$24.95
Moon Lander	16K		\$15.95
Dancin' Devil	16K		\$14.95
War Kings	16K		\$19.95
Spider	16K		\$19.95
Cave Hunter	16K		\$24.95
Haywire	16K		\$24.95
Astro Blast	16K		\$24.95

### Literature

Assembly Language Graphics	\$14.95
Basic Computer Programming for Kids	\$14.95
TRS-80 Color Computer Graphics	\$14.95

### NOW AVAILABLE Nelson Software

Super Color Writer	T.	\$49.95
.....	D.	\$99.95
Super Color Terminal	T.	\$39.95
.....	D.	\$59.95

### INTRACOLOR COMMUNICATIONS

Colorpede	16K	ML	T.	\$29.95
Rototattack	16K	ML	T.	\$24.95
.....			D.	\$27.95

### Educational

Speller	16K		\$16.95
Geo-Studies	16K		\$ 9.95
USA, Canada, Europe, Aust.			
Word Drill	16K		\$19.95
Math Drill	16K		\$19.95

### Adventures

Calixto Island	16K	ML	\$19.95
Black Sanctum	16K	ML	\$19.95

### Utilities

Copy Cat	16K	ML	\$19.95
Color DFT	16K	ML	T. \$19.95
.....			D. \$29.95

### Hardware

Grand Slam Solderless Kit ..... \$75.00  
For E or F Board and 1.1 Rom  
Please include \$10.00 REFUNDABLE tool deposit with order  
For All Boards  
Ram Slam Solderless Kit  
16-32K \$49.95  
15-minute installation  
**ONE YEAR WARRANTY**



# PATCHing The Patch: EDTASM+ To Disk Revisited

By Roger Schrag

In the December issue of *the Rainbow*, an article that I wrote showing how to patch Radio Shack's EDTASM+ to use disk appeared. Since then, I have gotten letters from various readers who were worried that they might have made a mistake because the "L" and "P" commands of Zbug wouldn't work properly. I would like now to explain that this is because the patch program as presented in the December *Rainbow* simply does not support the functions of Zbug. I have since modified the program slightly, and I would like to share my revisions with you.

First, let me say that if you have any problems, comments, or questions you may drop me a line at 2504 Manning Avenue, Los Angeles, California 90025. A self-addressed, stamped envelope would be helpful. I will do my best to reply promptly.

If you have patched your EDTASM+ to use disk and would like to see Zbug also support disk, then read on! The process is really quite simple. First insert the disk cartridge and turn on your computer. Now dig out your source code

for the program shown in the December article. If it is still on tape, transfer it to disk with the BASIC transfer program.

Next, load disk EDTASM+ and the old source code. If you used the same line numbering scheme that I did, then line 189 should be the end statement. Delete it. Now insert all of the code in the listing presented here from line 189 on.

If you didn't hold on to your source code from the December article, then you will need to load disk EDTASM+ and enter that listing first.

Whether you have updated your old source code or reentered the whole thing from scratch, double check for typographical errors. Then save the new source code on disk. Assemble it to disk as well.

Now, return to Disk BASIC. Load your present copy of disk EDTASM+, but don't execute it. Now load the new patch program that you just assembled. Finally, save the new finished product on disk with the command `SAVEM"EDTASM+",&HE80,&H37FF,&HE80`.

You now own the revised version of disk EDTASM+. To save a block of memory onto disk from Zbug, type "P", then the start-address, end-address, execution-address and press *ENTER*. You will be prompted for the filename. Type it in as you would in BASIC, but without the quotes. If you don't specify an extension, none will be assumed. Your block of memory will then be written to disk.

To load a file under Zbug, simply press L and *ENTER*. You will be asked for the filename, and the file will be loaded. By the way, Zbug has the ability to load a file into memory offset. I believe Radio Shack forgot to put this in the manual. If you want to load a file offset, then use this mickey mouse syntax: `L XYZ offset`. The XYZ is needed to keep the Zbug command evaluator from getting confused.

Finally, there is a patch to cure a problem with the Reset button. When you hit Reset, the SAM chip in the computer resets the interrupt control register. A patch is therefore needed to reprogram this register whenever Reset is pressed.

Incidentally, if you are wondering how the new Zbug patches work, they utilize the ROM routines that normally process the *LOADM* and *SAVEM* statements in BASIC.

That about rounds out the revisions to disk EDTASM+. I hope you will find my work helpful. Please feel free to drop me a line if you are having difficulties, or if you have any suggestions.

**The listings:**

- 00189 +
- 00190 +
- 00191 +NEW MATERIAL ADDED TO MAKE ZBUG
- 00192 +DISK COMPATIBLE, AND TO CURE A
- 00193 +FEW MINOR BUGS
- 00194 +



**Q-SOFT PRESENTS**

- **3D TIC-TAC-TOE** •

NEW!! Over 150 possible ways to win. A real challenge. Just when you think you won, coco beats you to it. A first for the coco.

Cassette:	32K E.C.B.....	\$14.95
Disc:	32K E.C.B.....	\$19.95
- **TIC-TAC-TOE** •

If you thought Tic-Tac-Toe is an easy game, try matching your wits against this version. Play it with or without joysticks. A special "SMALL FRY" level of difficulty is provided.

Cassette:	16K C.B.....	\$10.95
-----------	--------------	---------
- **JUMPS** •

Q-SOFT's challenging version of a very old European solitaire game. An ADDICTIVE board game in HI-RES graphics. Reviewed in Jan. 1983 issue of the "RAINBOW" on page 164.

Cassette:	16K E.C.B.....	\$10.95
Cassette:	4K C.B.....	\$ 8.95
- **THE SPIDER** •

By: CHROMATIC SOFTWARE". All machine language. Annihilate the spider before he destroys you. Arcade action. Joysticks needed. Reviewed in Jan. 1983 issue of the "RAINBOW" on page 160.

Cassette:	16K.....	\$19.95
-----------	----------	---------
- **ONE CHECK** •

48 "CHECKERS" are placed on the two outside rows of a standard checkerboard. Remove as many "checkers" as possible, jumping diagonally. Play with or without joysticks. HI-RES graphics.

Cassette:	16K E.C.B.....	\$10.95
-----------	----------------	---------

**Q-SOFT**  
 1006 ROBINHOOD DRIVE • PAINESVILLE, OHIO 44077  
 C.O.D. orders add \$3.00 Call 216-352-2675





# WORKSAVER RECEIVES RAVE REVIEWS

## FROM COLOR COMPUTER NEWS AND RAINBOW

- Fast Entry of Basic Programs
- Over 100 user definable keys
- Enhances all Coco's from 16K Non Extended Basic to Extended, 64K, Disk
- Available on Disk or cassette
- Built in cassette merge
- User's Support Service

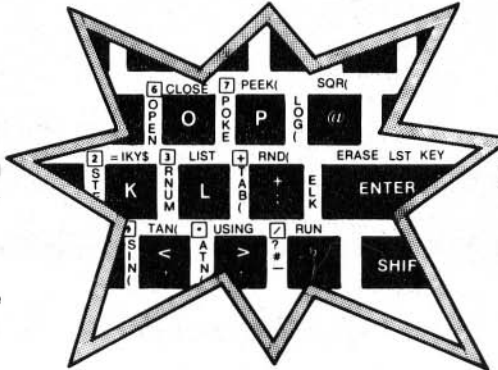

"There are a number of products on the Coco market...the WORKSAVER ranks up there with the best of them"  
—Rainbow Dec. '82

"...undoubtedly the best program I have ever bought for my color computer"  
—Color Computer News Jan. '83

"the main function of the program seems to be making things easier and more functional for the user. It succeeds extremely well"  
—Color Computer News Jan. '83

THE WORKSAVER WILL SAVE YOU HOURS OF WORK...WRITING AND DEBUGGING YOUR PROGRAMS"

—Rainbow Dec '82

### FULL SCREEN EDITOR

"WANT TO CHANGE the line a couple lines up? Simple Use the arrow keys to the appropriate place and make the change. This is not only a lot easier, but it is vastly faster, too. Changing line numbers, joining lines together, breaking them apart, duplicating them elsewhere—heady stuff—is very easy to do with the Work saver" (Rainbow)

### DYNAMIC EDITING

This is one of our users' favorite features. When the computer halts due to an error, or you want to make an improvement while running, you can make changes without losing data. This is a major plus in debugging...it can save a lot of time in data loads. (and) the generation of data through inputs. Rainbow Dec. '82

"The things that this program add to the color computer..."

### INCREASE ITS CAPABILITIES MANIFOLD

"...it should have been incorporated into the original MICROSOFT programming (or) given out with every color computer."

—Color Computer News Jan '83

### THE PLATINUM WORKSAVER INCLUDES:

- Enhancement program, including a sample array editor on a high-quality Agfa cassette
- Fully labeled acetate keyboard overlay, not a cheap stick on
- Complete instructions
- Loads in seconds, takes 2.2 K

### WORKSAVER A1-A3 OWNERS:

Contact us regarding return policy for our New A-4 version.

The PLATINUM WORKSAVER costs \$35.00 plus \$3.00 S&H (NY residents add appropriate tax). To order write:

PLATINUM SOFTWARE  
P.O. Box 833  
Plattsburgh, N.Y. 12901

Phone orders: (518) 843-2650 9-5 EST

VISA; MASTERCARD ACCEPTED. PERSONAL CHECKS TAKE 2-3 WEEKS TO PROCESS.



### DYNAMIC INPUT

Perform numeric calculations, and check the contents of arrays and variables, WITHOUT interrupting the running of BASIC programs: "An EXTREMELY valuable feature that I use ALL the time"

—Color Computer News Jan '83

### NUMERIC KEYPAD CONVERSION

"The keys JKLUIOP are defined as the numbers 1-7, respectively...this mode is a Godsend for long data statements"

—Color Computer News Jan. '83

### FULL FEATURED 4 COLOR KEYBOARD OVERLAY

"TRUTH: The WORKSAVER overlay is the best we have seen for this type of program"

—The Rainbow Dec '82

"A well designed keyboard overlay (NOT a sticker)"  
—Color Computer News Jan '83

UPGRADE YOUR COLOR COMPUTER



### GRAB BAG

GRAB BAG IS THE BIGGEST SOFTWARE BARGAIN AROUND. NOT A BUNCH OF SPACE-FILLERS BUT HANDY UTILITIES YOU CAN USE EVERY DAY. INCLUDES OUR EDITOR AND FILESYS, DISK RECOVERY, TAPE UTILITIES, AND MORE! MORE DETAILS IN OUR CATALOG ON TAPE NO 3. GRAB BAG IS \$49.95. GET BOTH GRAB BAG AND MASTER DISK FOR 69.95.

### MASTER DISK

TROUBLE FINDING YOUR DISK PROGRAMS? MASTER DISK TO THE RESCUE! ONCE YOU TRY IT YOU'LL WONDER HOW YOU EVER GOT ALONG WITHOUT IT. NO TYPING REQUIRED! MASTER DISK CREATES FILES DIRECTLY FROM YOUR DISK DIRECTORIES AND SEARCHES THEM IN 5 MODES. READ ANY DIRECTORY WITHOUT SWITCHING DISKS. SEARCH ALL YOUR DISKS FOR A DESIRED FILENAME. FIND DISKS WITH FREE SPACE. INCLUDES ACCESSORY PROGRAMS TO PRINT AN ALPHABETIC LIST OF ALL OF YOUR FILES (32K FOR SORT REQUIRED) OR REBUILD A CRASHED DIRECTORY. NEW UPGRADED VERSION STILL RUNS IN 16K SYSTEMS. \$49.95

### DUNGEON MAZE

TIRED OF READING YOUR WAY THROUGH ADVENTURE GAMES? TAKE A STROLL THROUGH THE DUNGEON MAZE! SEE THE ROOMS, PASSAGES, AND OBJECTS AS YOU PASS THROUGH. SEARCH FOR MAGIC ITEMS YOU NEED TO ESCAPE. FREE THE KIDNAPPED PRINCESS HELD CAPTIVE BY THE EVIL TROLL. BEWARE OF MAGIC TRICKS AND TRAPS! 32K EXTENDED BASIC REQUIRED. \$24.95

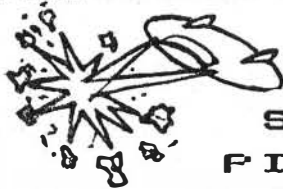

### STAR PILOT

TAKE A TREK INTO OUTER SPACE TO DEFEAT THE ENEMY FROM BEYOND THE GALAXY. THIS IS NOT JUST ANOTHER PUSH THE BUTTON AND SHOOT GAME. TO FIND AND DESTROY THE ENEMY YOU WILL NEED A STEADY HAND AT THE HELM, CLOSE ATTENTION TO YOUR CONTROL PANEL, AND A LITTLE LUCK. CALL YOUR CREW FOR REPAIRS, TRY A RUSE, OR GO IN FIRING TO SAVE OUR GALAXY. "SHIP'S COMPUTER" TELLS YOU SHIP'S STATUS OR A MAP OF THE KNOWN GALAXY. REQUIRES 16K EXTENDED BASIC AND INCLUDES 16K NOVICE VERSION AND 32K VERSION WITH MORE CHALLENGE. \$19.95

THIS IS A PACKAGE OF FOUR SIMPLE GAMES FOR CHILDREN. SOME NON-EXTENDED AND SOME EXTENDED BASIC. \$19.95

### JUNIOR GAMES

### REDUCED PRICES

EDITOR .....\$14.95  
FILESYS .....\$9.95

### CATALOG

OUR LATEST CATALOG ON TAPE (NO 3) REVISED FOR LATEST PRICES AND PROGRAMS IS \$3. FLIP SIDE HAS 2 NOVELTY PROGRAMS AND A TAPE UTILITY SIMILAR TO THOSE SEEN ADVERTISED FOR TWICE THIS PRICE. (SUCH A DEAL!)

MASTER DISK & GRAB BAG AVAILABLE ON DISK ONLY. CATALOG ON TAPE ONLY. ALL OTHERS, TAKE YOUR CHOICE. SAME PRICE! NO SHIPPING CHARGE. INDIANA RESIDENTS INCLUDE SALES TAX.

## Circle City Software

P.O. Box 30166

Indianapolis, Indiana  
46220

COMPU SERVE EMAIL NO. [71645,514]



- 00195 \*REVISION 1 - 01/19/83
- 00196 \*
- 00197 \*
- 00198 \*CLOSE FILES & RETURN TO ZBUG
- 00199 ZCLOSE JSR \$CA3B CLOSE FILES
- 00200 JMP \$1387 RETURN TO ZBUG
- 00201 \*
- 00202 \*
- 00203 \*ROUTINE TO REINITIALIZE THE
- 00204 \*SAM CHIP CORRECTLY AFTER
- 00205 \*RESET IS PRESSED
- 00206 RESET LDA #35 FIX INTERRUPT
- 00207 STA \$FF03 CONTROL REGISTERS
- 00208 LDA #34 OF THE SAM CHIP
- 00209 STA \$FF23 THEN RETURN TO
- 00210 JMP \$3270 EDTASM+ RESET ROUTINE
- 00211 \*
- 00212 \*
- 00213 \*MAKE SURE THE DISK FILE IS CLOSED
- 00214 \*WHEN ZBUG IS DONE WITH IT
- 00215 ORG \$2D88
- 00216 JSR ZCLOSE
- 00217 \*
- 00218 \*
- 00219 \*PATCH INTO THE RESET ROUTINE
- 00220 ORG \$326B
- 00221 JMP RESET JUMP TO THE PATCH
- 00222 \*
- 00223 \*
- 00224 \*FIX INPUT ROUTINE SO THAT IF YOU
- 00225 \*RESPOND TO "FILENAME?" PROMPT BY
- 00226 \*HITTING BREAK, YOU WON'T ACCIDENTALLY
- 00227 \*RETURN TO THE EDITOR
- 00228 ORG \$1EF0
- 00229 LBER \$172F
- 00230 \*
- 00231 \*
- 00232 \*MAKE ZBUG'S "P" COMMAND WRITE
- 00233 \*TO DISK, BY USING THE ROM ROUTINE
- 00234 \*THAT PROCESSES THE BASIC
- 00235 \*COMMAND "SAVEM"
- 00236 ORG \$16C9
- 00237 JMP \$CEA2 GO TO ROM ROUTINE
- 00238 \*
- 00239 \*
- 00240 \*MAKE ZBUG'S "L" COMMAND LOAD
- 00241 \*FROM DISK, BY USING THE ROM ROUTINE
- 00242 \*THAT PROCESSES THE BASIC
- 00243 \*COMMAND "LOADM"
- 00244 ORG \$1641
- 00245 LDU #LOAD GET THE FILENAME
- 00246 JSR \$15C9 & OPEN IT FOR INPUT
- 00247 PULS X GET THE OFFSET
- 00248 STX >D3 AND STORE IT
- 00249 PSHS DP SAVE DP
- 00250 CLRA CLEAR THE
- 00251 TFR A,DP DIRECT PAGE
- 00252 JSR \$CF07 USE ROM ROUTINE
- 00253 PULS DP,PC RESTORE DP & RETURN
- 00254 END START

# OS-9 • 6809 • FLEX

The same system software on FLEX, OS-9, SSB DOS, RS DOS — offers portability and easier learning — for Color Computer and SS-50 systems

## SCRIBE EDITOR

- ★ Many commands compatible with familiar editors for easy learning.
- ★ Edit files larger than memory.
- ★ Many easy line edit commands including insert, change, delete characters within a line.
- ★ Macros for repeated edit sequences.
- ★ Merge files from disk to create programs or manuscripts.
- ★ Interfaces with Text Processor for word processing.
- ★ Great with Macro Assembler!

### WHY COMPUTERWARE

- ★ Only Computerware offers system software on ALL major 6809 operating systems.
- ★ 7 years of 68XX experience and unmatched expertise.
- ★ As you change operating systems, there is no need to re-learn system packages.
- ★ No-one can match the quality for the price.

## RANDOM BASIC

- ★ Thousands of existing programs are now transportable to other operating systems.
- ★ Extraordinary File Handling Capabilities — ISAM, Random, & Sequential file structures; FAST data file access; Very efficient file design — records can bridge sectors.
- ★ 11 Digits of precision — BCD arithmetic for those who need extended precision.
- ★ Flexible User Input Commands — "Conversational" programming is a snap with commands designed for easy user input — single character or whole lines.
- ★ Easy Output Formatting — Print Using, automatic pagination, left & right justification, easy columnization and decimal point alignment.
- ★ Programming's Fast — The interpreter provides fast program development and debugging — it is self-documenting with extended variable names.

## MACRO ASSEMBLER

- ★ All Standard 6809 mnemonics and directives supported.
- ★ Macros allow you to create often-used routines only once!
- ★ Conditional Assembly allows you to build only one multi-purpose source code to generate several versions, reducing maintenance significantly!
- ★ Repeat Sequences eliminate redundant coding.
- ★ Any Size Source File — assembles from disk.
- ★ XREF program included for easy cross-reference listings
- ★ Addressing Modes: inherent, immediate, relative, direct, extended, and indexed — all addressing modes!

FLEX is a trademark of TSC  
OS-9 is a trademark of Microware

CALL  
OR  
WRITE  
FOR  
COMPLETE  
INFORMATION



Dealer Inquiries Invited

Box 668  
6809 Specialists Encinitas, CA 92024 • (619) 436-3512

Computerware is a trademark of Computerware



# RECEIVED & CERTIFIED

The following products have been recently received by *the Rainbow*, examined by our magazine staff and approved for the *Rainbow Seal of Certification*, your assurance that we have seen the product and have ascertained that it is what it purports to be.

This month the *Seal of Certification* has been issued to:

**TRS-80 Programmers Sourcebook**, First edition, a 67-page (8½ x 11), soft-cover book featuring listings for application software, reference publications and computer clubs. Edited by J. Bradley Flippen, OCEAN, P.O. Box 2331, Springfield, VA 22152, \$4.95.

**Basic Programming Primer**, a new, expanded second edition, 368-page ringbound soft cover, (9 x 6½), primer for those who want to learn BASIC. Written by Mitchell Waite and Michael Pardee. Published by Howard W. Sams & Co. Inc., P.O. Box 7092, Indianapolis, IN 46206, \$17.95.

**Pro-Color File**, Version 2.0, 32K disk system. The 2.0 version is being sold for \$79.95; however, owners of the 1.0 version should have already received letters offering the new version for a \$20.00 upgrade fee, which includes a new manual and diskette. Available from Derringer Software, P.O. Box 5300, Florence, SC 29501

**Super-Pro Replacement Keyboard Kit**, a direct replacement professional keyboard kit for CoCo and the TDP-100. It has the same key layout as your original keyboard. Mark Data Products, 24001 Alicia Pkwy., No. 226, Mission Viejo, CA 92691, \$69.95.

**Dynacalc**, an electronic spreadsheet program with a 41-page manual for Flex users. Sold by Computer Systems Center, 13461 Olive Blvd., Chesterfield, MO 63017, \$200.

**Spectran**, a program written for the 16K or 32K Disk ECB. Allows you to translate *Spectaculator* files to ASCII, or vice versa. Available from Crimson Software, 32 Beverly Heights, Tuscaloosa, AL 35404, \$25.

**Church Contributions Program**, software and 20-page manual package primarily designed to facilitate the task of recording envelope collections. Maintains its own data files. Available from Universal Data Research, Inc., 2457 Wehrle Dr., Buffalo, NY 14221, \$99.

**Single Entry Ledger**, software and a 10-page manual. Designed to handle ledger entries for home and small businesses. Compatible with the company's Data Base Manager program. Also available from Universal Data Research, Inc., \$95.

**Balanced Billing Program**, software and 15-page manual provide a menu-driven, billing package that maintains its own data files, provides reports, and prints invoices and mailing labels. Also available from Universal Data Research, Inc., \$99.

**Data Base Manager**, software and manual for the TRS-80 Model III and CoCo. This program is designed to organize all your data and provide you with meaningful re-

ports. Also available from Universal Data Research, Inc., Part I-\$99., Part II-\$99.

**Moneypak**, a 32K ECB learning program for home or school which enables youngsters to gain skill in using money and making purchases. Package includes play money and is available from Computer Island, 227 Hampton Green, Staten Island, NY 10312, \$22.95.

**Old McDonald's Farm Vowels**, an educational vowel drill program for beginning readers through second grade. Requires 16K ECB. Available from Teksym Corp., 14504 Country Road 15, Minneapolis, MN 55441, \$14.95.

**Grand Slam Bridge**, a 32K card game program. Available from Greentree Software, P.O. Box 97, Greenwood, IN 46142, cassette \$19.95.

**3-D Tic-Tac-Toe**, a game for one player against CoCo, or two players against each other. More than 150 winning combinations. On cassette, 32K ECB, \$14.95 or 32K disk \$19.95. Available from Q Soft, 1006 Robinhood Drive, Painsville, OH 44077.

**Zaxxon**, an arcade-style game. Objective: you are a pilot of a fighter spacecraft on a mission to meet and destroy the deadly Zaxxon robot. Available from Data Soft, Inc., 9421 Winnetra Avenue, Chatsworth, CA 91311, cassette or diskette \$39.95.

**Zaksund**, a "3-D color graphics," arcade style game in 32K machine language. Objective: fly your spaceship through enemy starbases and avoid guided missiles, lasers, and firing turrets, and reach their leader—Zaksund. KORG Polysix Synthesies sound. Available from Elite Software, Box 11224, Pittsburgh, PA 15238, \$24.95 cassette, \$27.95 disk.

**Deprec**, Multiple Depreciation Analysis, a program that will calculate depreciation expense using various methods. Available from B. C. Engineering, P.O. Box 768, Manchester, MO 63011, \$10.95.

**Intrst I**, Home Interest Calculator, a program that will calculate answers for various question about loans or money deposited in interest bearing accounts. Also available from B.C. Engineering, \$12.95.

**INSIMB**, a 6809 machine code instruction simulator which uses about 8K. Together with *Insimt* (included), will simulate all 6809 instructions. Also available from B. C. Engineering, \$39.95.

**Stock Option Strategies** allows you to devise your own stock option strategies, covered

options, straddles, calls and puts, percent gains and losses. Graphed in color. No data base is required. Menu driven, 16K cassette. Available from Greentree Software, P.O. Box 97, Greenwood, IN 46142, \$14.95.

**Doubleback**, Graphics game for 4K and joysticks. One or two players. Accumulate points by circling an assortment of objects as they materialize on the screen. Challenge posed by rapidly fading trail and obstacles which suddenly appear in your path. Radio Shack Catalog No. 26-3091, \$24.95.

**The Sands of Egypt**, an Adventure game with graphics. As you attempt to overcome the scorching elements of the desert, you try to find the treasure in as few moves as possible and claim the treasure. Radio Shack Catalog No. 26-3290, \$29.95.

**Color Disk Spectaculator**, an electronic spreadsheet program that does forecasting, planning, budgeting and problem solving. Includes a 54-page manual divided into five parts. Radio Shack Catalog No. 26-3256, \$59.95.

**Personafile**, is a central filing system for 16K or 32K ECB. It allows up to 540 records with up to 250 different subjects. Radio Shack Catalog No. 26-3260, \$59.95.

**Color Disk Scripsit**, word processing program. Lets you create correct-free letters, themes and reports. Radio Shack Catalog No. 26-3255, \$59.95.

**Madness & the Minotaur**, a 16K Adventure game. You are a prisoner in the Labyrinth castle and are trying to escape from seven creatures with six treasures divided among them. Radio Shack Catalog No. 26-3313, \$14.95.

**TRS-80 Color Computer Quick Reference Guide**, a 71-page ringbound, softcover (8½ x 3½), manual. Radio Shack Catalog No. 26-3194, \$4.95.

**Images II**, a data tape packed with pictures for the programs *Art Gallery* and *Micro Painter*. Radio Shack Catalog No. 26-3301, \$8.95.

**Vocabulary Tutor I**, an educational vocabulary program for ages 8-10. Uses pictures, text and recorded speech for the TRS-80. Radio Shack Catalog No. 26-2568, \$8.95.

**Color Graphic Printer Package**, a series of programs including a bar graph and pie graph for use with Extended Color BASIC, the CPG-115 color printer and one joystick. Available from Dragonfly Software, 12503 Davan, Colesville, MD 20904, \$18.

**Game Package I**, includes *Alien*, *Starship* and *MX Missile Peace Keeper*. ECB and one joystick. Available from Dragonfly Software, 12503 Davan, Colesville, MD 20904, \$14.

The *Seal of Certification* program is open to all manufacturers of products for the TRS-80 Color Computer, the TDP-100, or the Dragon-32, regardless of whether they advertise in *the Rainbow*. By awarding a *Seal*, the magazine certifies the program *does exist*, but this *does not* constitute any guarantee of satisfaction. As soon as possible, these hardware or software items will be forwarded to *the Rainbow's* reviewers for evaluation.

—Jutta Kapshammer

# THE GREATEST SOFTWARE DEAL ON EARTH

Radio Shack  
Color Computer  
TDP  
System 100



Tame your computer without breaking your wallet's spirit! Quality programs on tape for the price of peanuts!

A subscription to **Chromasette Magazine** consists of 6 to 8 ready-to-load useful, practical, and fun programs delivered by First Class Mail every month. Programs like Curve Fit, Diggem, Graph Text, List Mod, Robot Run, House Adventure, and Keep Text.

Treat yourself to a great show — get a subscription to **Chromasette Magazine**. Or catch a single act and try a back issue. You'll be delighted by the tricks your computer will do!

---

**The Bottom Line:**

1 year (12 issues) \$50.00  
6 months  
(6 issues) \$30.00  
Single Copies \$ 6.00

Calif. residents add 6% to single copies.

North America — First Class postage included.

Overseas — add \$10 to subscriptions and \$1 to single copies. Sent AO rate.

**The Fine Print:**

All issues from July 1981 available — ask for list. Programs are for the Extended BASIC model and occasionally for disks.

---



**Chromasette** MAGAZINE

P.O. Box 1087 Santa Barbara, CA 93102 (805) 963-1066 MasterCard/Visa

# Let's Share Some Of Your Useful Hints

By Joseph Kolar  
*Rainbow Contributing Editor*

Nobody has a monopoly on ideas! You may have found an easier, simpler or less expensive way to do something that may be of use to *Rainbow* readers. If it is not too advanced or complex, why not sit down and write up your hint, observation or innovation? Send it to me at 1706 Dickinson Street, Inverness, Florida, 32650. We, through *the Rainbow*, will share it with others beginners.

Let's pause and consider some hints and suggestions that you may, or may not, find useful.

Have you noticed all the good ideas and hints that appear in *the Rainbow*? Why not copy the ones that you feel are useful or interesting into your personal reference notebook? Never cut them out of *the Rainbow*. You will only be chopping up a good reference source. Copy the essence into your private reference notebook and if some of them are of doubtful value now but show promise for the future when you become more sure of yourself, why not reserve a page in your notebook, listing the gist of the hint, the page and issue of *the Rainbow*? Later on, as your horizons expand, you can easily locate and refer to it.

The information in *the Rainbow* never gets stale and for you recent beginners who have just subscribed to *the Rainbow*, it will be wise to consider purchasing the back issues. Now, that's a hint!

You have been having fun making up and saving some programs to tape. About every six months, after you have absorbed and digested new information and have advanced in ability, pull out and review some of the programs that you created. They need not be long and involved but they should be your own work.

You will discover that you have new insights and expanding awareness regarding your programming abilities and will see many ways to improve, enhance or expand your earlier works. So, what are you waiting for? Rework the program!

Two things will be verified: 1) the extent of your progress since you first created the program; and 2) your increased ability to utilize your new knowledge. In fact, you may have advanced far enough to say, "bye, bye, beginners!" and head for higher ground.

When you are making up a program, it is best to put in the REM after you are finished. You can tack REMS after individual lines to clarify what the line contains. Sometimes, in your REM you may refer to other line numbers. If you decide to RENUM the program lines, the RENUM feature will not change the line numbers in the REMs. Often, you forget to check the REMs and change the reference to line numbers. When running through the listing, those REMs will be incorrect, useless and confusing. So, make it a point to put in the REMs just before you put it on tape.

Let's say you have a cassette tape that contains many programs, your tape is positioned after the last entry, and you want to CLOAD the last program. You can avoid wasting time rewinding to the beginning and then fast forwarding by doing the following: 1) reset counter to 000; 2) subtract the ending number of the program from the program; 3) rewind until you get the counter back the

required units. (Example: program is 14 units long. Add two, which results in 16. rewind to 984). Cload "XXX" ENTER. If you get an I/O message, it means you overrode the start of the program. Back up a few more digits and try again. Now you know one of the benefits of listing the ending counter number on the title card as well as leaving ample space between programs.

Be careful when going into the EDIT mode not to absentmindedly key in 1250 instead of EDIT 1250 and then press ENTER. This will delete line number 1250 and you will have nothing to edit. Likewise if you key in 1250 or 1250-1280 when you intended to key in LIST 1250 or LIST 1250-1280 and press ENTER, you will delete line number 1250 in both cases. You are likely to make these errors when in a frenzy of creativity your hand is quicker than your eye.

The only real solution is that when you key in EDIT, or LIST specific lines, you scan the entry before pressing ENTER. If you practice this cautionary action, you will soon make it an automatic response. This is one of those times when haste makes waste!

A similar error may occur when you are in the EDIT mode and want to press the "X" to get to the end of the line. You may press the "C" in error. Again, make it a point when pressing the "X" to see that you are really at the end of the line. Otherwise, you may wind up doing strange things to the line you are editing.

If you own a LPVII printer and use the screen print program (R.S. 26-3021), you may inadvertently press the "shift" and "up arrow" while you are editing your listing and the printer is on. This will start your printer clacking away, creating an unwanted picture and wasting your time.

Happily, there is a solution available in your home. Search around the house for a bottle cap that is about the size that is on an aspirin tablet bottle. Some thimbles may fit. Break off the handle from a plastic coffee measure if it is the small size.

Just place the cap over the "up arrow" key and you can edit to your heart's content without worrying about pressing that no-no key.

Remember that spring-loaded clothespin that you use on the extended handle of your cassette player to hold work that you are copying? That clothes pin can also serve as a handy pencilholder. Just press the pencil between the two pieces. It will be held firmly and be ready for action whenever you are.

If you are using an improvised typing-stand as described in the first article, you may find that many soft-covered books, as well as hard-covered books, will not stay open to a desired page. The pages have a tendency to flip over and lose your place.

You can solve this easily. Use the cardboard backing of an 8½ x 11 writing tablet, a piece of stiff corrugated cardboard, a piece of veneer plywood, plexiglass or some other suitable, thin-but-firm material.

Open your soft-covered book to the desired page, clip each side of the open book, at the upper right corner and the



# AARDVARK

TRS-80 COLOR

COMMODORE 24

VIC-20

SINCLAIR/TIMEX

TI99



**QUEST** — A NEW IDEA IN ADVENTURE GAMES! Different from all the others. Quest is played on a computer generated map of Alesia. Your job is to gather men and supplies by combat, bargaining, exploration of ruins and temples and outright banditry. When your force is strong enough, you attack the Citadel of Moorlock in a life or death battle to the finish. Playable in 2 to 5 hours, this one is different every time. 16k TI99, TRS-80 Color, and Sinclair, 13K VIC-20. \$14.95 each.

32K TRS 80 COLOR Version \$24.95.

Adds a second level with dungeons and more Questing.



## CATERPILLAR

O.K., the Caterpillar does look a lot like a Centipede. We have spiders, falling fleas, monsters traipsing across the screen, poison mushrooms, and a lot of other familiar stuff. COLOR 80 requires 16k and Joysticks. This is Edson's best game to date. \$19.95 for TRS 80 COLOR.



## ADVENTURES!!!

The Adventures below are written in BASIC, are full featured, fast action, full plotted adventures that take 30-50 hours to play. (Adventures are interactive fantasies. It's like reading a book except that you are the main character as you give the computer, commands like "Look in the Coffin" and "Light the torch.")

Adventuring requires 16k on Sinclair, TRS-80, and TRS-80 Color. They require 8k on OSI and 13k on VIC-20. Sinclair requires extended BASIC. Now available for TI99. Any Commodore 64.

\$14.95 Tape — \$19.95 Disk.

## ESCAPE FROM MARS

(by Rodger Olsen)

This ADVENTURE takes place on the RED PLANET. You'll have to explore a Martian city and deal with possibly hostile aliens to survive this one. A good first adventure.

## PYRAMID (by Rodger Olsen)

This is our most challenging ADVENTURE. It is a treasure hunt in a pyramid full of problems. Exciting and tough!

## DERELICT

(by Rodger Olsen & Bob Anderson)

New winner in the toughest adventure from Aardvark sweepstakes. This one takes place on an alien ship that has been deserted for a thousand years — and is still dangerous!

**Dungeons of Death** — Just for the 16k TRS-80 COLOR, this is the first D&D type game good enough to qualify at Aardvark. This is serious D&D that allows 1 to 6 players to go on a Dragon Hunting, Monster Killing, Dungeon Exploring Quest. Played on an on-screen map, you get a choice of race and character (Human, Dwarf, Soldier, Wizard, etc.), a chance to grow from game to game, and a 15 page manual. At the normal price for an Adventure (\$14.95 tape, \$19.95 disk), this is a giveaway.

**WIZARDS TOWER** — This is very similar to Quest (see above). We added wizards, magic, dragons, and dungeons to come up with a Quest with a D&D flavor. It requires 16k extended color BASIC. \$14.95 Tape, \$19.95 Disk. VIC 20 Commodore 64.



NEW

**PLANET RAIDERS** — Not just another defenders copy, this is an original program good in its own right. You pilot a one man ship across a planetary surface dogfighting with alien ships and blasting ground installations while you rescue stranded troopers. Rescue all the troopers and be transported to another harder, faster battle. Joysticks required. ALL MACHINE CODE! EDSONS BEST! 16K Tape TRS80COLOR \$19.95 — 32K Disk \$21.95.

## BASIC THAT ZOOMS!!

### AT LAST AN AFFORDABLE COMPILER!

The compiler allows you to write your programs in easy BASIC and then automatically generates a machine code equivalent that runs 50 to 150 times faster.

It does have some limitations. It takes at least 8k of RAM to run the compiler and it does only support a subset of BASIC—about 20 commands including FOR, NEXT, END, GOSUB, GOTO, IF, THEN, RETURN, END, PRINT, STOP, USR (X), PEEK, POKE, \*, /, +, -, >, <, =, VARIABLE NAMES A-Z, SUBSCRIPTED VARIABLES, and INTEGER NUMBERS FORM 0-64K.

TINY COMPILER is written in BASIC. It generates native, relocatable 6502 or 6809 code. It comes with a 20-page manual and can be modified or augmented by the user. \$24.95 on tape or disk for OSI, TRS-80 Color, VIC 20, or Commodore 64.

**SEAWOLFE** — ALL MACHINE CODE In this high speed arcade game, you lay out patterns of torpedoes ahead of the attacking PT boats. Requires Joysticks, at least 13k RAM, and fast reflexes. Lots of Color and Sound. A fun game. Tape or Disk for Vic20, Commodore 64, and TRS-80 Color. \$14.95 Tape - \$19.95 Disk.

**Dealers** — We have the best deal going for you. Good discounts, exchange programs, and factory support. Send for Dealer Information.

**Authors** — Aardvark pays the highest commissions in the industry and gives programs the widest possible advertising coverage. Send a Self Addressed Stamped Envelope for our Authors Information Package.

**Adventures and Quest now available for TI99**

Please specify system on all orders

ALSO FROM AARDVARK — This is only a partial list of what we carry. We have a lot of other games (particularly for the TRS-80 Color and OSI), business programs, blank tapes and disks and hardware. Send \$1.00 for our complete catalog.

## AARDVARK

2352 S. Commerce, Walled Lake, MI 48088 / (313) 669-3110

Phone Orders Accepted 8:00 a.m. to 4:00 p.m. EST. Mon.-Fri.

\$2.00 shipping on each order





upper left corner with two clothespins. Place it in position on your stand and you will be able to type without the annoyance of flipstand and you will be able to type without the annoyance of flipping pages. Experiment to get the best results for your personal set-up.

This will also work effectively on hard-covered books and magazines provided that they are not too bulky. When not in use, clip the clothespins to the desk lamp you have in back of your stand or in some convenient place. The clothespins make good conversation pieces when you have visitors to your work area.

A neat way to keep *the Rainbow* open to a desired page when you want to key in some listing, is to open the magazine to the desired page, loosely fold the facing page in back of the cardboard/wood backing and clip it in two places, with you know what, on the top edge with the backing in between. When finished with that side, it should be no problem to clip the other side, except that the loose fold will be on the opposite side.

If you are copying from slick paper that reflects light, and you use a desk lamp in back of your typing stand, you will find by moving the lamp around that the portion you are copying can be made reflection-free.

Finally, if your cassette gets much use, the "play" key may not remain depressed because it is worn. As a temporary remedy, when pressing the "play" key, wedge one of the tapered ends of a clothes-pin in back of the "play" key and it will keep it in position so that you will be able to play and/or record until you get it fixed.

There is a way to fix the "play" key without returning it to Radio Shack or buying a new cassette, if it is a CRT-80A. Mine has gone out a few times and since it is working fine, the rule is: don't fool with it! When it goes again, I plan to write up the remedy in detail and offer it as a hint in a future

article. In the meantime, if you are having problems with the "play" key on your CRT-80A, drop me a line and I will be glad to give you the remedy.

Keep creating, and if you have some hint to share, let this article be your conduit.



## Back Issue Availability

Back copies of many issues of *the RAINBOW* are still available.

All back issues sell for the single issue cover price—which is \$2 for copies of Volume 1, Numbers 1-8 (through February, 1982), \$2.50 for Volume 1, Numbers 9, 10 and 12 (through June except May, 1982) and \$2.95 for those issues thereafter. In addition, there is a \$3.50 charge *per order* for postage and handling if sent by United Parcel Service and \$6 for orders sent U.S. Mail. UPS *will not* deliver to a post office box or to another country. This charge applies whether you want one back issue or all of them.

Most back issues are available on white paper in a reprint form. Issues out of print include May, July, August, September, October, November, and December, 1982 and January, February, 1983. VISA, MasterCard and American Express accepted. Kentucky residents please add 5 percent state sales tax.

Due to heavy demand, we suggest you order back issues you want now while supplies last.

In addition, copies of the cover *only* of the July, 1982, Anniversary Issue are available separately for \$1 each, plus 50 cents shipping and handling. These are suitable for framing.

# VOICE RECOGNITION

For your 16K TRS-80 Extended Basic Color Computer

*Using your cassette recorder's condenser microphone, the COLOR TALK TO ME software package can let you use your own voice as an alternate means of input for any of your BASIC programs. Over 200 words can be stored in 16K RAM. With a little practice, you can attain from 80% to over 90% accuracy for most applications.*

The COLOR TALK TO ME Software Package includes:

- COLOR TALK TO ME machine language subroutine
- The BASIC subroutine which can merge COLOR TALK TO ME with your programs
- Complete instructions on how to use and incorporate COLOR TALK TO ME in BASIC programs
- Two application programs:

1. VOICE CALC— Use your voice to enter arithmetic problems and VOICE CALC will display the solution.
2. SCREEN PAINTER— Say a color and the screen will be painted that color.

ALL OF THIS ON TWO CASSETTES FOR ONLY \$49.95!!!

ColorSoft Software will soon be releasing voice recognition programs which can be used once you buy COLOR TALK TO ME. Coming soon: Connect More, Crosswords & more!

ATTENTION PROGRAMMERS: ColorSoft Software will market original voice recognition programs using COLOR TALK TO ME with excellent royalties in return.

Dealer  
Inquiries  
Invited

Send check or money order to: ColorSoft Software Co.  
Add \$2.00 shipping  
MI residents add 4% sales tax  
11764 Raintree Ct.  
Utica, MI 48087

# WE DO BASIC BETTER!

## Experience High Resolution Graphics and Speed Unsurpassed in Color Computer Extended Basic Software

### GALLOPING GAMBLERS

Those who have tried it agree that *GALLOPING GAMBLERS* is so addictive, so exciting, that you and your whole family will all cheering for your horse to win.

No joysticks are required for this 4 player game. Place your bets on the variable odds and then wait for the sound of post time...and...they're off.

Game includes color graphics with score and bird's-eye view of the race track. Can you last all twelve races?

We dare you to try.

**\$18.95**

### GATOR ZONE-

Is the first video computer game that takes a "byte" out of the Prppy craze! You can finally get even with those pesky Ivy League snobs by blasting away at a hoard of Preppy Gators on their home planet of "Preptune". You have to be quick, or the gators will gobble up your shirt! This is comic arcade fun at its best. Includes high-resolution graphics, on-screen scoring, joystick action, and three levels of play. An IMB original!

**\$18.95**

### STAR SIEGE PLUS-

Discussed with Space Battle games in which your space craft looks like an asterisk?

*STAR SIEGE* lets you and your friend (or enemy) pilot two high resolution space ships while trading laser blasts. The first to take ten hits loses, but watch out for that pesky alien saucer! He wants to see to it that you both get vaporized.

Also includes two player *TANK TORCHER* game.

**\$18.95**

### METEOR STORM-

If you are bored with space obstacle games that place you as a distant observer from a point far off in space, then *METEOR STORM* is for you. Enjoy the thrill of blasting the approaching meteors from the cockpit of your own spacecraft. Watch the meteors grow in size until...

16K Color Extended Required. Includes sound enhanced laser blasts, multi game scoring, and three levels of play.

**\$12.95**

### SELECT-A-GAME-

combines 3 of IMB's finest bonus games in one simple load! You can switch back and forth from "ALPINE ALIENS", "OH, GOBI", and "ZELDA'S BAT BOTTLE". All contain stunning color graphics and high speed action. Even if you already own one or more of these games, you will want this fine package.

**\$18.95**

### MICRO-MATH SKILLS QUIZ-

is a fine math drill for students at or below the 3rd grade math level. Includes automatic grade tally, and INKEY entry with large print, high-resolution graphics. This is a must for educators!

**\$12.95**

### CREATAVADER-

Now you can design your own "invader-style" game for your Color Computer. Includes all the routines needed for customizing the creatures you hate the most. Full instructions included. Create your own targets or select from a menu of seven pre-designed four color targets.

**\$18.95**

### COLOR WORDCLONE-

Turn your Color Computer into a supertypewriter for your Color Computer. Includes all the routines needed for customizing the creatures you hate the most. Full instructions included. Create your own targets or select from a menu of seven pre-designed four color targets.

**\$18.95**

### KOSMIC KAMIKAZE-

Our best selling high-resolution, deep space arcade game which the RAINBOW called "...the best spaceship graphics we have seen in a non-machine language program." Battle high speed alien saucers, decoy ships, bonus killer crafts and speeding comets.

**\$18.95**

ADVANCED

### STAR\*TRENCH WARFARE-

This High Resolution Color Game has the most elaborate graphics of any Color Computer Game created to date. You'll be amazed by the remarkable speed and flicker-free animation found in this graphic space challenge. Program includes a moving trench, cockpit perspective, on-screen rapid scoring, energy and ship gauges, automatic high score tally, joystick control, and a recharge and crash sequence you'll have to see to believe. Use your own 3-D glasses and add an amazing sense of depth to this classic game. Truly a must for every Color Computer.

**\$18.95**



### STARBASE ATTACK-

Why be a loser? Here's an arcade game you can play to win. In other space city defense games you play until you lose. *STARBASE ATTACK* is totally different. Your mission is to clear a path for the escape vehicles which will carry your people to safety. Not only that, but you must also maneuver your own escape before alien warheads or a wave of killer asteroids level your dome-covered cities. You control high energy laser blasts and expansion shields, but watch out! You might end up the one who doesn't escape.

**\$12.95**

**SUPER DISC WITH ALL 11 PROGRAMS  
A VALUE OF \$171.50 JUST \$59.95 POST. PAID.**



**ILLUSTRATED MEMORY BANKS  
P.O. BOX 289  
WILLIAMSTOWN, MA 01267**

**• VISA AND MASTERCARD ACCEPTED •  
CALL (413) 663-9648 3-7 PM. EST.**



**MENTION THE RAINBOW AND SELECT ONE FREE PROGRAM FOR EVERY TWO \$18.95 PROGRAMS YOU ORDER.**

## Federal Hill Software

### Coco-Accountant

Was income tax a chore this year? Use the power of your Color Computer to make those deductions a breeze. Keep track of household or business expenses quickly and easily using data from your canceled checks. 16K version handles 200 entries; 32K handles up to 450. Both versions:

- \* List expenses by month
- \* List expenses by account (year or month)
- \* List expenses by payee (year or month)
- \* Sort checks by date
- \* List to screen or printer.

In addition, 32K version flags deductible checks, flags checks subject to sales tax and computes the sales tax you paid. 16K or 32K Cassette \$15.95. 32K Disk \$21.95.

### Blackjaq!

This is as close as you can get to the real thing without losing your shirt. A full casino simulation with five players and dealer, up to six decks and lightning fast action. Play alone (the computer plays vacant hands by card-counting rules) or invite your friends. Blackjaq keeps track of everyone's winnings and losings, gives card counting pointers, and, at your option, prints out the results of every hand. Amazing value. 16K EXT. Tape \$19.95. Disk \$24.95.

### Koko Math!

Are your kids bored with educational programs? Let KOKO the math clown make arithmetic a joy. Get 10 problems right and give him a bath. Colorful graphics and music will make this program a hit with your youngsters. Add subtract, multiply or divide; three difficulty Does not require Ext. Basic. \$8.95.

### Printer Art!

Turn your printer into an artist with this collection of 12 printer drawings. Clipper ship, palm trees, witches, Christmas cards and other delightful compositions to decorate report covers, hang on the wall or amuse your friends. Use program as is or pull out drawings for subroutines in your own programs. 16K EXT. Tape \$14.95, Disk \$19.95.

Federal Hill Software  
825 William Street  
Baltimore, Maryland 21230

Software Review . . .

## LLIST-Rite A Handy Inexpensive Utility

You cannot tell a book by looking at the cover. The same evidently holds true for looking at software's document. When I looked at the documentation for *LLIST-RITE* I did not see anything spectacular that the program was going to do for me (this is not saying the documentation is inadequate—I will cover that later), I was in for a pleasant surprise.

First and foremost, you need CoCo, a printer, and a cassette. *LLIST-RITE* comes on a cassette and runs in 16K or 32K Extended BASIC. It can be used to *LLIST* and length BASIC program that is *CSAVED* in ASCII format. The ASCII version can be simply gotten by *CSAVE* "program name," A. It observes page boundaries, e.g., gives you eight character wide left/right margins and margins at the top and bottom of each page.

*LLIST-RITE* prints in two columns which saves paper for its type of listing. It sets the line numbers apart from the text of the program where they can be easily found, breaks down multiple statements, and lists *IF-THEN-ELSE* on separate lines so they logically make sense. It also gives you a screen display of the line it is currently working on, so you know where the program is at all times.

*LLIST-RITE* has only 4,367 characters and therefore *CLOADS* quickly. It is written totally in Extended BASIC and has plenty of *REM's* to help you understand how it works and modify it if you desire. I modify most programs I buy to make them customized for *my* use so this was especially handy for me.

*LLIST-RITE* has a short but adequate documentation which states (in part) "If dissatisfied with *LLIST-RITE* return package for a full refund." I would like to see this added to the documentation of all the software for CoCo. I'm quite a dreamer!

I loaded *LLIST-RITE* in my 32K CoCo, picked out a program that I had previously *CSAVED* in ASCII, and began to get a listing on my Line Printer VIII, Beautiful!

*LLIST-RITE* lists your program in two columns, gives adequate margins for storing in a three-ring binder, and makes the listing highly legible. Since a picture is worth a thousand words. . .

Here is a sample *LLIST* of a program using CoCo's ROM!

```
520 LN=25-J:Q=2:GOSUB 770:IFLEN(  
I$)>2THEN GOSUB 810:LN=LEN(I$):J  
=-1:L$(I)=L$(I)+" ":GOTO 500 EL  
SE N=0:I$="":GOTO700
```

Here is the exact same line the way *LLIST-RITE* says it!

```
520  * LN=25-J  
521  * :Q=2  
522  * GOSUB 770  
523  * :IF LEN(I$)>2  
524  * THEN GOSUB 810  
525  * :LN=LEN(I$)  
526  * :J=-1  
527  * :L$(I)=L$(I)+" "  
528  * :GOTO 500  
529  * ELSE LN=0  
530  * :I$=""  
531  * :GOTO 700
```



# Nanos Systems Corp. REFERENCE CARDS For Models I, II, III, Color, Pocket and Apple II & II Plus



"Micro-man Images"



\* TRS-80 is a Registered Trademark of Tandy Corp.  
Computer picture reprinted permission Tandy Corp. APPLE is a registered trademark of Apple Computing, Inc.

Each card is a complete summary of the reference manuals and the microcomputer. Cards are two or more colors, printed on 80 pound Beckett Antique cover stock or a comparable stock, stretch-wrapped in plastic for shipping. They are accordion-foldup cards, in the same style as the traditional IBM reference cards used on the major computers for years. Fold-up size is eight and one-half by three and three-quarter inches, so they will fit easily into the shirt pocket. These cards provide a complete summary of the manuals plus many extras at your fingertips.

MODEL I	MODEL II	MODEL III	COLOR	APPLE II & II PLUS
<p><b>BASIC: Buff &amp; Blue</b> 5 Panels, 10 Pages (For the Classroom) Memory Map. Easy Graphics. Basic Statements. Basic Functions. Basic Facts. Special Characters. Basic Commands. Edit Subcommands. PRINT USING Examples. Message &amp; Codes. Reserved Words. Special Keys. Ascii Character Chart, with Space Compression Codes. Control Codes. Basic Internal Codes. Hex/Dec Conversion Chart. Screen Line Layout. <b>BASIC &amp; ASSEMBLER: Buff</b> <b>8 Panels, 16 Pages</b> (For the Pro) Complete Z80 Instructions. Assembler Instructions. Commands, Operators. Editor/Assembler Commands, and Edit Subcommands. Flags, Conditions, &amp; Chart. Internal Routines. Assembler Error Msgs. Plus Most Items in the Basic Card</p>	<p><b>BASIC &amp; ASSEMBLER: Green</b> 10 Panels, 20 Pages (For the Business) Small Memory Map. Screen Layout. Easy Graphics. Complete Z80 Instructions. Series-1 Assembler Instr. Commands, Operators, and Edit Subcommands. Assembler Error Msgs. Power-up Error Msgs. Flags, Conditions, &amp; Chart. Wild Cards, DOS Messages. SVC Procedure Panel. Host Logon Panel. Version 2.0 Lib Command Formats and System Utility Formats. Basic Functions &amp; Statements. DOS File Naming Convention. Basic Commands &amp; Edit Subcommands. Special Keys. Basic Internal Codes and Reserved Words. Basic Msgs. &amp; Codes. PRINT USING Examples. Special Characters. "DO" Utilities &amp; BASIC Command. Ascii Character Chart with SVC Names and Numbers. Control Codes.</p>	<p><b>BASIC: Blue &amp; Buff</b> 6 Panels, 12 Pages (For the Classroom) Special Characters. Kana Characters. Euro-Characters. Memory Map. Special Keyboard Functions. Ascii Char. Chart w/Space Compression Codes. Control Codes. Cassette Loading Err Msgs. Basic Commands, Edit Subcommands, Special Chars., Basic Statements, Facts, Functions, Derived Functions, Special Operations (POKES), PRINT USING Examples. Basic Msgs. &amp; Codes. Basic Internal Codes. Reserved Words. Screen Line Layout. <b>BASIC &amp; ASSEMBLER: Blue</b> <b>10 Panels, 20 Pages</b> (For the Pro) Complete Z80 Instructions. Assembler Instructions, Commands, Operators. Series 1 Editor/Assembler Commands &amp; Edit Subcommands. Flags, Conditions, &amp; Chart. Hex/Dec Conversion Chart. Assembler Error Msgs. Internal CALL Routines. Break Processing Procedure. Plus all items in the Basic card.</p>	<p><b>BASIC &amp; EXTENDED:</b> 6 Panels, 9 Colors. 8 Panels 16 pages (For the Artist) <b>All Color Graphics.</b> System Commands. PRINT USING Examples. Special Characters. Special Keys. Cassette Loading Err Msgs. Basic Functions &amp; Statements. Playing Music, Making a Circle, and Drawing Panels. Derived Functions. Messages &amp; Codes. Musical Notes, by Octave, in Color, Including Rests and Time. Memory Map. Reserved Words. Internal Codes. A Page of Tips. Ascii Char. Codes Chart. Including Inverse Graphics and Color Graphics. Control Codes. Color Group Chart. Pmode Information Summary. Screen Line Layout. Extended Graphics Pmode Illustrations.</p>	<p><b>BASIC: Red &amp; Pink</b> 7 Panels, 14 Pages (For the Classroom) 48K Memory Map APPLESOFT and INTEGER BASIC. Basic Statements. Basic Functions. Derived Functions. Special Characters &amp; Operators. System &amp; Utility Commands. Pokes, Peeks, Calls. Monitor Commands. Key &amp; Control Functions. APPLESOFT Internal Codes. APPLESOFT Reserved Words. Integer Basic Addressing. DOS 3.3 Command Summary. Color Selection Chart. Error Msgs. &amp; Handling. Reading Machine Language. Hex/Dec Conversion Chart ASCII, Print, Video, 6502, Integer and APPLESOFT Code Reference Chart, 0-255. <b>Basic &amp; 6502: Red</b> <b>8 Panels, 16 Pages</b> (For the Pro) All features of the Basic Card, Plus: 6502 Timing. 6502 Language Simplified. Flags &amp; Conditions with Reference Chart.</p>

POCKET	Please send me:	Card	Price
<p><b>BASIC: Purple</b> 5 Panels, 10 Pages Operating Characteristics Memory Types and Limitations Modes of Operation. PRO Mode. RUN Mode. RESERVE Mode. DEF Mode Fixed Variable Facts and References. System Function Keys. Math and Logic Function Keys. Normal Character Keys. Special Characters and Function Keys. Basic Commands. Cassette Interface Commands. Reserved Words. Math and Numeric Functions. Derived Functions. Basic Statements. Error Messages and Codes. USING Statement Examples and more. . . . !</p> <p>A pocket card for your pocket computer.</p>	( )	Copies of MODEL I BASIC & ASSEMBLER	\$4.95
	( )	Copies of MODEL I BASIC-ONLY	2.95
	( )	Copies of MODEL II BASIC & ASSEMBLER	5.95
	( )	Copies of MODEL II SVC	2.95
	( )	Copies of MODEL II COMMANDS & UTILITIES	3.95
	( )	Copies of MODEL III BASIC & ASSEMBLER	5.95
	( )	Copies of MODEL III BASIC-ONLY	3.95
	( )	Copies of COLOR BASIC AND EXTENDED	4.95
	( )	Copies of POCKET BASIC	2.95
	( )	Copies of APPLE II & II PLUS BASIC	3.95
	( )	Copies of APPLE II & II PLUS BASIC & 6502	4.95
	( )	Copies of Z80	4.95
	( )	Copies of ZX80, 81, & TIMEX SINCLAIR-1000	5.95
	( )	Copies of HEATH/ZENITH HDOS for H8/H89/Z89/Z90	5.95

Ask for them at your store or bookstore or order from us.

Wholesale prices available in quantities over 24.

Send Check or Money Order to:  
NANOS SYSTEMS CORP.  
P.O. BOX 24344  
SPEEDWAY, IN 46224  
(317) 244-4078

NAME: \_\_\_\_\_  
ADDRESS \_\_\_\_\_  
CITY \_\_\_\_\_ STATE \_\_\_\_\_ ZIP \_\_\_\_\_

Indiana Residents Add 5 Percent for Indiana Sales Tax



Definitely impressive, huh? Notice how missing spaces are inserted so the commands are more legible. *IF, THEN,* and *ELSE* are put on separate lines. The line number is set off from the rest of the statement. I am an instructor/supervisor for computer maintenance people and most of my programming endeavors involve word processing. To more efficiently use memory, I use a "shrink" program that removes all spaces and, for speed, I use multiple program statements whenever I can. This insertion of spaces and separation of multiple statements certainly complements my reading after the writing his "cooled," *LLIST-RITE* numbers and prints a very meaningful heading at the top of each page. This is extremely useful in "getting your act together" if you save and refer back to listings from time to time.

It certainly makes your listings more legible, storable, and your "bugs" easier to find. The program is written in Extended BASIC so you can make changes, if necessary. It is internally documented with ample *REM*'s which helps you to understand how it does its thing. *LLIST-RITE* is very user-friendly. I believe anyone could use it.

A disadvantage is that it's slow! It took me just over 26 minutes to *LLIST LLIST-RITE* which contains 4,367 memory locations and it used more paper than CoCo's *LLIST* would use.

The documentation is good. It is short (one page) but contains the information needed to be off and running with superlative *LLISTS*. I noticed a couple of typographical errors but nothing worth noting.

I would like to see *LLIST-RITE* revised to enable the user to *LLIST* a segment of a program. The way it is now, it is either list all or nothing. I found one "bug" which resulted in a *FC ERROR* in 500 when the program was listing a line where I had a *REM* with no statement following it (this, by the way, is a very unusual programming tactic). I notified CoCo-Data and suggested a fix. They immediately wrote back and said they were able to duplicate the problem, tested my solution, and it was universal. They also changed the master tape so future programs sold will be "bug-free."

Should you buy it? This is where you must consider the sacrifice of time versus the gain in readability and bug-finding. Will there be an overall time savings? Just remember, they guarantee satisfaction or your money back—even the shipping and handling charge is refunded. Not many software retailers have that much pride in authorship. I really appreciated the timeliness of the response I got when I wrote them. In their letter to me, they said they offer pre-purchase information sheets (as opposed to selling the manual) for the asking. *LLIST-RITE*'s information sheet has a partial sheet of a listed program (using *LLIST-RITE*) and a general overview of the instructions. As you can see in the parenthetical data, the price is a small one to pay for an item that will make your computing a happier experience. Whatever your decision, I sincerely hope this review helps you make an educated one.

(CoCoDATA Enterprises, 1215 Emerald Drive, Orlando, FL 32808, \$5.95)

—Herbert B. Ridge

# The Original FLEX for Color Computers

- \* Upgrade to 64K
- \* RS to FLEX, FLEX to RS file transfer ability
- \* Create your own character set
- \* Automatic recognition of single or double density and single or doubled sided
- \* All features available for either single or multiple drive systems
- \* Settable Disk Drive Seek Rates
- \* Faster High Resolution Video Display with 5 different formats
- \* Save RS Basic from RAM to Disk
- \* Move RS Basic to RAM
- \* Load and save function on FLEX disk
- \* 13 Support Commands 8 with Source Text Languages Available

Pascal, Fortran, RS Basic, RS Assembler, TSC Basic, TSC Assembler, Relocating Assembler, Macro Assembler, Mumps

If you are tired of playing games on your TRS-80C™ Color Computer, or find that you are handicapped by the limitations of the RS BASIC in trying to write a Program that will allow you to actually USE the Color Computer as a COMPUTER, YOU ARE READY TO MOVE UP TO THE FLEX9™ Operating System. If you want to have REAL PROGRAMMING POWER, using an Extremely Powerful Business BASIC, PASCALS, C Compilers, a full-blown Macro Assembler with a Library capability so you are not continuously "reinventing the wheel", YOU ARE READY TO MOVE UP TO THE FLEX9™ Operating System. If you would like to see if YOU REALLY COULD USE A COMPUTER IN YOUR BUSINESS, or begin to make your Computer start PAYING ITS OWN WAY by doing some Computer Work for the millions of small businesses around you, such as Wordprocessing, Payroll, Accounting, Inventory, etc., then YOU ARE READY TO MOVE UP TO THE FLEX9™ Operating System. How?? DATA-COMP has the way!

DATA-COMP's FLEX9™ Conversion for the TRS-80C™ Color Computer was designed for the SERIOUS COMPUTER USER; with features like greatly increased Display Screens, WITH Lower Case Letters, so you can put a FULL Menu on ONE Screen, or see SEVERAL Paragraphs at the same time; with features like providing a FULL Keyboard so you have FULL Control of your Computer AND its Programs NATURALLY, without needing a chart to see what Key Combination will give you what function; with USER ORIENTED functions to make using the Operating System natural, like having the Computer AUTOMATICALLY determine what type of Disk is being used in what type of Disk Drive and working accordingly, rather than you have to specify each and every thing for it, or like having the Computer work with the Printer you have been using all along without you having to tell the new Operating System what is there; etc., etc., etc.

DATA-COMP has everything you need to make your TRS-80C™ Color Computer WORK for YOU; from Parts and Pieces to Full, Ready To Use SYSTEMS. DATA-COMP designs, sells, services, and SUPPORTS Computer SYSTEMS, not just Software. CALL DATA-COMP TODAY to make your Computer WORK FOR YOU!

## System Requirements

FLEX9 Special General Version x/Editor & Assembler (which normally sell for \$50.00 ea.)	\$150.00
F-MATE(RS) FLEX9 Conversion Rout. for the RS Disk Controller when purchased with Special General FLEX9 Sys.	\$69.95
when purchased without the General FLEX9 Sys.	\$79.95
Set of Eight 64K RAM Chips w/Mod. Instructions	\$69.95
Color Computer with 64K RAM and EXT. BASIC	\$499.95
Color Computer with 16K RAM	\$289.95
Color Computer with 16K RAM and EXT. BASIC	\$389.95

## SPECIAL SYSTEM PACKAGES

64K Radio Shack COLOR COMPUTER, Radio Shack COLOR DISK CONTROLLER, a Disk Drive System, Special General Version of FLEX9™, F-MATE(RS)™ and a Box of 10 Double Density Diskettes; a COMPLETE, ready to run SYSTEM on your Color TV Set. \$1249.95

## DISK DRIVE PACKAGES, etc.

These Packages include the Radio Shack Disk Controller, Disk Drives with Power Supply and Cabinet, and Disk Drive Cable:

PAK #1 — 1 Single Sided, Double Density Sys.	\$499.95
PAK #2 — 2 Single Sided, Double Density Sys.	\$769.95
PAK #3 — 1 Double Sided, Double Density Sys.	\$599.95
PAK #4 — 2 Double Sided, Double Density Sys.	\$949.95
PAK #5 — 2 Qume Thinline Double Sided Double Density Sys.	\$764.95

## PARTS AND PIECES

Radio Shack Disk Controller	\$179.95
1 Tandem Single Sided, Double Density Disk Drive	\$249.95
1 Tandem Double Sided, Double Density Disk Drive	\$349.95
1 Qume Thinline Double Sided, Double Density	\$279.95
Single Drive Cabinet with Power Supply	\$89.95
Double Drive Cabinet with Power Supply	\$109.95
Single Drive Disk Cable for RS Controller	\$24.95
Double Drive Disk Cable for RS Controller	\$34.95
Micro Tech. Prods., Inc. LOWER CASE ROM Adapter	\$74.95
Radio Shack BASIC Version 1.1 ROM	\$34.95
Radio Shack Extended Basic ROM	\$89.95

DATA-COMP

P.O. Box 794 HIXSON, TN 37343  
1-615-842-4601



## Spectrum Switcher Gives You Fine ROM Pack Flexibility

The *Spectrum Switcher* is, by far, the easiest-to-use device we have yet encountered to keep two ROM Packs or cartridges "on line" at the same time.

Now, before you get the idea that you can keep two cartridge programs in memory simultaneously, let us say that such isn't possible to do—at least as far as we know. In other words, do not expect to be able to "combine" two programs at once.

But, the big hassle, at least for us, has always been the need to plug the disk controller in and out, depending on whatever else we might be using. The *Spectrum Switcher* eliminates that problem for once and for all.

The *Switcher* is a flat, lightweight plastic case with a cable on one end that plugs into CoCo's expansion port. It also has two connectors—for two ROM Packs. In addition, there are two switches and two sets of LEDs. Everything is clearly and attractively labeled.

You plug one cartridge into one of the ports and another into the other. Then, just turn on CoCo and it will start up selecting the cartridge in slot B. A simple flick of the switch turns off whatever is in slot B and turns on the cartridge in slot A. Just in case you can't tell from the screen, there is an LED to indicate which slot has been selected.

The other switch determines whether you want the cartridge to auto-start. If you want to make backups of cartridges on disk for your own use, this eliminates the necessity of taping over the pins in the cartridge. For those

of us who like to transfer carts to disk to make access quicker, this is a major boon.

We like the *Spectrum Switcher* because it is very easy to use, looks nice and, in some pretty extensive testing, worked without fault. It also has gold contacts, which help eliminate problems associated with poor connections. It also eliminates the problem of plugging and unplugging cartridges into CoCo itself—which does cause wear on the expansion port.

We found only one problem with the *Switcher*, although it was minor. That is it is possible to lose a BASIC program in memory if you press the reset button on CoCo or switch one of the switches. Given the ability to switch back and forth between ROM Packs (especially when you have a disk drive) and to disable the auto-start function, the *Spectrum Switcher* is a fantastic device you will want to add to your setup. If you have a disk drive and are faced with the problem of unplugging and plugging it in, the *Switcher* is almost a necessity.

(Spectrum Projects, 93-15 86th Drive, Woodhaven, NY 11421, \$99.95)

Hint . . .

## Print Out Disk Directory

If you have a long disk directory and want to see all of it, or if you simply wish to have a hard-copy printout of your directory, one simple command will allow you to do this easily.

Just POKE 111,254:DIR and the entire disk directory will appear on your printer, even if it is too long to be fully displayed on the screen.

---

# Find The COLOR COMPUTER INFORMATION YOU NEED COLOR COMPUTER INDEX COLOR COMPUTER CATALOG

---

American Library and Information Services  
Dept. R, 3705 Mary Ellen NE, Albuquerque, NM 87111

Gentlemen:

- Yes! Send me **COLOR COMPUTER INDEX 1980-1981** at \$5 (Canada and Mexico \$6)
- Yes! Sign me up for **COLOR COMPUTER INDEX 1982** (4 issues) for \$16 (Canada and Mexico \$20)
- Yes! Sign me up for **COLOR COMPUTER CATALOG 1982** (two issues) for \$20 (Canada and Mexico \$24)
- YES! Sign me up for Color Computer Index 1983** (Six issues for \$24—Canada & Mexico \$30)
- YES! Sign me up for Color Computer Index 1983** (Two issues for \$20—Canada & Mexico \$24)

Single Issues:

**Color Computer Index \$6 U.S.** (Except 1980-1981)  
**Color Computer Catalog \$12 U.S.**

Name \_\_\_\_\_  
Address \_\_\_\_\_  
City \_\_\_\_\_ State \_\_\_\_\_ Zip \_\_\_\_\_

## The 8-Bit Bartender A Versatile, 32K Mixologist

All of you beer drinkers can skip this review if you like, but maybe if you read it you will learn something, like how to mix a "Rusty Nail." *The 8-Bit Bartender* by Prickly-Pear Software will be the center of attraction at your next party. Written for 32K Extended BASIC the tape version is loaded with a *CLOADM* and *ENTER*. As in other popular software by the same company, an auto-run feature takes care of the rest and gives you something to look at in the meantime. The program is also available on disk.

After loading the program, you are greeted with a chorus of "How Dry I Am" while a bubbling cocktail glass provides the animation. With the *8-Bit Bartender*, drinks can be searched in three fields. You can ask for a drink by name, main liquor or category.

More than 100 various cocktails are in the directory. The different categories are color-coded as to the type of glass

they use. If you ask for a drink not on the menu, the program will inform you "I don't serve that!!!" The authors claim that extensive research was conducted in cocktail lounges in major cities to compile the list of 100 different drinks.

Well, that was just too hard to believe, so I set out on my own fact-finding mission. You can actually get all of these drinks in any well equipped bar within a short jump from your home. But let me warn you, don't ask your neighborhood bartender for "Velvet Hammer" or a "Dirty Mother" or you may be drinking alone with your computer.

After your supply of booze is exhausted, if you can still read or hear, exiting the program will entone a line of "The Party's Over." I think this novel program will be the talk of your next party if you can find someone sober enough to type. Now, how about a "Glog," no, make it a "Silver Bullet," no . . .

(Prickly-Pear Software, 9822 E. Stella Road, Tuscon, AZ 85730, \$19.95 on tape)

—Dan Downard

\*\*\*\*\*ANNOUNCING A NEW PRODUCT\*\*\*\*\*

LINE PRINTER VII COVER

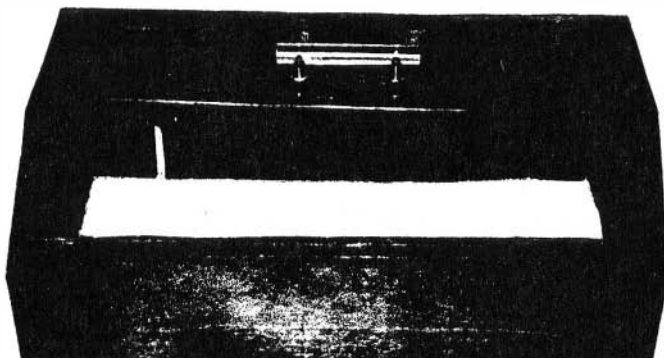

THIS REMARKABLE COVER REDUCES THE NOISE BY MORE THAN HALF AND IS AVAILABLE IN 6 DIFFERENT COLORS FOR THE LOW PRICE OF ONLY \$34.95 ea.

THE COLOR CHOICES ARE American Walnut, Bark, Oriental Teak, Spanish Oak, Palm, and Cherry. SPECIAL COLORS ARE AVAILABLE FOR \$5.00 EXTRA

THESE COVERS ARE MADE OF QUALITY WOOD (COVERED WITH LIQUID PLASTIC) AND PLEXIGLAS WITH PRE-CUT SLOTS FOR CORDS AND PAPER TO GO THROUGH.

SEND CHECK OR MONEY ORDER TO:



**PcLEAR4co.**

P. O. BOX 294

HENDERSON, TEXAS 75653-0294

Distributors of Quality Color Computer Equipment

Please send \_\_ LP-VII Covers @ \$34.95 in the \_\_\_\_\_ Color To \_\_\_\_\_

Please include \$3 for S & H. per cover

PLEASE ALLOW 3 to 4 WEEKS FOR DELIVERY

ICCC MEMBERS 25% OFF!

# Quality Software Is The Number One Priority At

## K & K Computerware



**LASER TANK** - Pit yourself in a game of strategy and excitement against the computer. You must defend your flag from attacking tanks and destroy them before they destroy your flag or you!!! High resolution graphics and four levels of difficulty. Only \$14<sup>95</sup>

**GAZON** - A machine language game that is surpassed by none on the market. The deadly Gazonians are trying to steal your supplies and you must stop them by shooting or ramming them. Action increases as fleets of Gazonians are destroyed. Only \$15<sup>95</sup>

**SHOOT TO SPELL AND FLASH MATH** - An educational package that helps kids learn to spell and educate them on elementary math. An absolute must for adults with school aged children. Joysticks required. Only \$12<sup>95</sup>

**SPACE HARVEST** - Pilot your spacecraft above the Planetoid Voltar stealing spacefruit and trying to avoid alien guards and the ground. Fast action machine language programs with high resolution graphics. Only \$14<sup>95</sup>

**HORSE RACE** - Can you pick the next Secretariat among our thoroughbreds? High speed, life like action for people of all ages. High resolution graphics. Only \$12<sup>95</sup>

**SERIALTOPARELLELCONVERTER** - Have a printer with a parallel port? Tired of waiting for a line list? With this little hardware device you can make your color computer run at any baud rate between 300 and 9600. Let K & K help your printer to go much faster!!! Only \$69<sup>95</sup>



**BLACKJACK** - A casino game that puts two players against the beady-eyed dealer of the house. This dealer deals the cards as good or even better than Intellivision. If you have any gambling blood at all this game is a must! Same rules as any Las Vegas casino. High resolution graphics. Only \$12<sup>95</sup>

**ALL GAME PROGRAMS** - require 16K extended (prices are set for cassette, add \$4<sup>00</sup> for disk, except business)

**PROGRAMMERS!!!** - K & K pays the highest royalties for your programs. If your program is good, send it to K & K and receive the best possible coverage!

**TRS-80 COLOR COMPUTER USERS** - New programs are added each week. Send \$1<sup>00</sup> for our complete catalog.



**K & K COMPUTERWARE**  
37326 Gregory Drive • Sterling Heights, Michigan 48077  
Telephone: (313) 264-7345



**POLARIS** - You are under the ocean in a submarine, attacking planes and enemy destroyers dropping depth charges attempting to destroy your sub. Can you destroy them before they destroy you? This is an extremely fast action machine language program with high resolution graphics. Only \$14<sup>95</sup>.



**SUPER ZAP** - Enemy spaceships are attacking from all sides and your mission, should you choose to accept it is to defend your starbase from the deadly Armada of Pyrus. This will be a dangerous mission since the Pyrus Armada has never been defeated by any humanoid. Action increases as the game progresses. Only \$14<sup>95</sup>

**HOME HELPERS** - Have problems balancing your checkbook, remembering important dates or phone numbers, and your mailing lists. Let K & K and your color computer help you. Only \$14<sup>95</sup>

**BOWLING SCORED FOR DOLLARS** - Do your leagues bowling averages. This program will keep individual scores, team totals, individual averages, team standings, and print all this information to your line printer. Minimum 16K disk required (on cassette too!). Only \$14<sup>95</sup>

**INVENTORY CONTROL** - This program contains all the necessary features required for all types of inventories, such as sorting of inventory by stock number. This program will list stock number, description, amount in stock, cost, wholesale, profits. Minimum 16K disk required. Only \$39<sup>95</sup>

**PROPERTY INVENTORY** - This program lists inventory by department, date purchased, and property numbers. Minimum 16K disk required. Only \$29<sup>95</sup>

**ACCOUNTS PAYABLE AND RECEIVABLE** - These two programs will control the incoming and outgoing money flows for all your business accounts. Only \$59<sup>95</sup>



# Storing Files To Cassette Tape

By

Richard A. White

*Rainbow* Contributing Editor

The cassette interface is one of many CoCo features that sets it apart from other microcomputers. In fact, the cassette system is so bad in many other systems that disk drives are considered mandatory for any serious application, even in the home environment. Most serious CoCo owners now have only cassettes (as I write this). I expect defections from the ranks, myself included, since Radio Shack has taken a chunk out of the price of the Disk 0 drive. Still, cassettes will be a force and market for as long as I can see. I can then write a column on cassette operations only and know that I am addressing the needs of most *Rainbow* readers. File characteristics are so similar in cassette and disk operations that there is meat here for all.

There are three separate types of Color Computer files. First is the program file, BASIC or machine language. Next is the ASCII file which may contain numeric and string data or a non-tokenized BASIC Program. Third, there are special files like those generated by *Spectaculator* which can only be read by the program that made them. A pox on the house of authors who write these.

A BASIC or a machine language program file is nothing more than a sequential copy of a section of memory in the computer. They differ by code in the header that tells the computer which type is being loaded so it can handle the information properly. The locations of the beginning and end of a basic program are kept in memory. When a BASIC program is saved, all bytes between these two addresses are read to tape. When a BASIC program is reloaded, it starts filling memory at the beginning of BASIC then set and continues until all the program is in or until it runs out of memory when our friend, OM ERROR, appears. In Color BASIC, start of BASIC is 1537. In Extended BASIC it's 7680 at *PCLEAR4*, but can be changed by *PCLEARing* a different number. If you get an OM ERROR when loading a long program type *PCLEAR1* and try loading it again.

A machine language file carries its beginning address, end address and its execution address in its header and the computer copies the code into the defined stretch of memory. You can offset the file to a new location in memory by adding an offset value to the *CLOADM* statement like this: *CLOADM* "PROGNAME", 1000 where 1000 offsets the code up 1000 bytes. Whether the program will run offset is another matter. A pox on the house of authors who write non-relocatable code.

An ASCII file may be thought of as processed data rather than a direct memory dump. The data is found, processed in some way and copied into a buffer location. When the buffer is full, a header is written to tape and the whole buffer is copied to tape. The process continues, buffer by buffer, until all data is saved and the file is closed. A hand is up in the back of the room. What is an ASCII? ASCII refers to a standard numeric code representing characters and control codes. A carriage return is 13 while an A is 65. The whole list is in the back of your manuals. You can also ask the compu-

ter by typing ?ASC(A) and it will respond with a 65.

A BASIC program may be saved in ASCII format by the simple command *CSAVE*"PROGNAME",A. Why? How is this different from the regular save? When a line of BASIC is entered into the computer, some machine language code called the interpreter looks for basic words like *PRINT*, *IF*, *INPUT* etc. When it finds a BASIC word, it looks up a number or pair of numbers for that word, called tokens, and puts the token in memory rather than the whole word. This saves memory and speeds program execution. When you make an ASCII save, the interpreter untokenizes the BASIC line putting the BASIC words back in the line and puts the line into the buffer as a character string. In this form, the program can be read into a running BASIC program as data to be used in one way or another. Most terminal programs send and receive only ASCII files. The computer is smart enough to sort out whether the BASIC program being loaded is in ASCII or tokenized format. You will note that when loading an ASCII save of a BASIC program, the cassette stops and waits after loading each buffer while the interpreter tokenizes each line and saves it to memory.

At the outset, I suspect you expected to learn about saving and loading data from a BASIC program. Now is the time. We already have laid some ground work and you know about the buffer and ASCII codes. When you *Open* a file, either out, "O," to the cassette or in, "I," from the cassette, you commit the buffer and start interaction with the cassette.

Statement	Action
OPEN "0",-I,"FILENAME"	The cassette is turned on and a header with file type and file name are sent to the recorder.
OPEN "I",-I,"FILENAME"	The cassette is turned on a read looking for the header with file type and file name. If file names match, the first data buffer is loaded and the cassette is stopped.

Data is saved by putting it into the buffer with the *PRINT#-I*, *I\$* or *PRINT#-I*, *I* commands. Either strings or numbers may be sent in any order. *I\$* and *I* can be any variable names including script variables. Pieces of data are separated in the buffer by carriage returns. When the buffer is full, it is sent to tape; you did remember to leave the recorder on and in record mode, I hope. Data can be sent as it is generated or collected in memory and dumped all at one time. In a contest scoring program, I opened the entrants' file at the beginning, and the program saved a buffer every now and then as entries were typed in. This assured that if the program bombed, data entered to that point could be recovered. Data was also kept in memory and a complete second save was

# NOVA-PINBALL

AN EXCITING NEW PINBALL SIMULATION FOR THE  
 COLOR COMPUTER! WITH ALL THE ACTION THAT'S  
 MADE IT AN ALL TIME FAVORITE!

\$20



# NOVA

**HIGHER  
 COLOR**

**FEATURES.**

- Arcade Action Graphics and Sound
- 4 Players
- Live Action Flippers
- Action Bumpers and Thumpers
- Double and Triple Bonus Scores
- Extra Bonus Ball
- Ball Kicker



## CYBORG WARS

LIKE THE ARCADE!

ROBOTS ARE INVADING EARTH IN  
 WAVE AFTER ADVANCING WAVE!

Your mission is to destroy all robots and save the  
 surviving humans. Watch for the missile firing BRAINS  
 and the fatal touch of the HULKS!

\$18

ALL  
 PROGRAMS  
 MACHINE  
 LANGUAGE  
 REQUIRE  
 16k

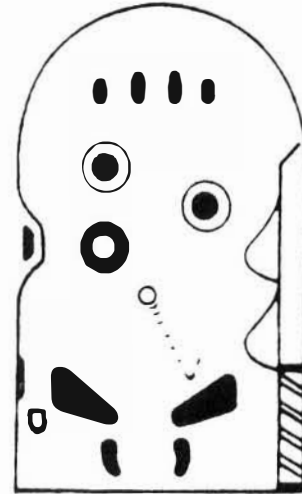

## PAC-MAC

Great PAC-MAN action!

\$15

## BUG-ZAP

Shoot bugs in formation, before they swoop down  
 to attack you!

\$9

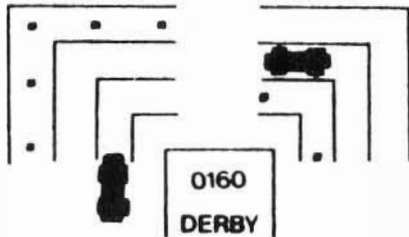

## DERBY

Race around the track with a computer controlled  
 car in pursuit Like the arcade, DODGE-EM!

\$14

## BUMBLEBEE SOFTWARE

Color Computer Machine Language Programs

P.O. Box 25427  
 Chicago, IL 60625

# ARCADE ACTION!

**HOPPY**



**NEW!**

GUIDE HOPPY SAFELY HOME TO HIS  
 DOCK. TRAVEL ACROSS A HIGHWAY AND  
 HOP ON LOGS & TURTLES TO GET THERE!  
 LIKE THE ARCADE!

\$18

DEALER, AUTHOR INQUIRIES INVITED

made when entries closed. Care was necessary to assure that the second save contained exactly the same data in exactly the same order as the first.

The data loaded back into the cassette buffer from tape (or into a disk buffer) must be read into variables for storage. This is done with the *INPUT#-1*, or *LINE INPUT#-1*, statements (disk uses + numbers, i.e., *INPUT#+1*), which takes data from the buffer and moves it to string or numerical storage as appropriate. When a buffer is emptied, the computer stops, reads in another buffer full and is on tape is only a sequence of pieces of data. No variable names are saved. When you reload the data you must write your code so that data is *INPUT#-1*, or *LINE INPUT#-1*, into the proper variables, both by type and name. If you change your save routine to save another variable, or not save one if that be the case, you must make a corresponding change in your input code. Further, when you do this, previous files will be unloadable. You will need to make a special version of the cassette routines to read in old files and save them out in the new format.

Following are two of the simplest file saving routines and their corresponding loading routines:

```
800 OPEN "0",-1,"STRINGS" :FOR X = 1 TO
PRINT#-1, A$(X)
:NEXT :CLOSE-1
850 OPEN "1",-1, "STRINGS" :X=1
860 IF EOF THEN CLOSE-1 :GOTO 1000 ELSE
LINE INPUT#-1, A$(X)
:X=X+1 :GOTO860
900 OPEN "0",-1,"NUMBERS" :GOTO100
910 PRINT#-1, A, B, X1, Y1, Z1 :RETURN
(The file is opened and control returned to the main
```

routine to get the data. Each time a data set is ready to save the line 910 subroutine is called. When done a *CLOSE-1* could be in the main program.

```
950 OPEN "1",-1,"NUMBERS" :GOTO300
950 IF EOF THEN CLOSE-1 :GOTO1000 ELSE
INPUT#-1, A, B, Z1, Y1, Z1 :RETURN
```

(The file is opened and control returned to the main program that calls 950 when it wants data. When end of file, EOF, is reached, the file is closed and control sent elsewhere.)

In the Strings code, there was an array of a known number of strings which was sequentially read to tape. When the file was loaded the strings were read with a counter X incremented after each input. *LINE INPUT* was used instead of *INPUT* in case there were any quotes, commas or colons in the data strings. *INPUT* has trouble with these. At end of file, EOF, the file is closed and control goes elsewhere. In the Numbers file, sets of non-subscripted numbers were saved until the main program was done and the file closed. The *PRINT#-1*, statement is shown as a subroutine, but it would probably be better in the main program. The file is read back in using an *INPUT#-1* to enter the same variables in exactly the order they were read to tape.

In the Numbers case there probably was no way of knowing how many file entries there would be. In the Strings case we did know and can use the following code:

```
800 OPEN "0",-1,"STRINGS" :PRINT#-1, Y :FOR X=1
TO Y :PRINT#-1, A$(X) :NEXT :CLOSE-1 :GOTO
1000
850 OPEN "1",-1,"STRINGS" :INPUT#-1, Y :FOR X=1
TO Y :LINEINPUT#-1, A$(X) :NEXT :CLOSE-1
:GOTO 100
```

Since we know how many records are on file and read that value in first, inputting can be in a simple *FOR-TO-NEXT* loop without a branch. Some like the top down aspect of this code better. Just because we have an end of file command, we don't have to use it.

In a complex program like a data management one, a number of variables and data arrays need to be saved in the file. It is imperative to tightly control the structure of the file and duplicate the structures in both output and input modes. Fortunately the input code is essentially a copy of the output code with *INPUT#-1* or *LINEINPUT#-1*, substituted for *PRINT#-1*. If you are writing in *EDTASM+* or using a utility like Toolkit or Basic Aid, you can copy the output code and edit it to input lines easily.

Now for cleaning up the details. Always save the file twice! Tape is cheap and the time lost in regenerating a program or file will pay for hundreds of double saves. Cowards can save three times and win occasionally. Since many times we are starting a fresh tape, put in code to choose to run past the leader. I always put code in early in the development of a program to save it to tape.

```
10000 AUDIOON :INPUT"RUN PAST LEADER":IS
:IF IS="Y" THEN MOTORON :FOR X=1 TO 6000
:NEXT
10010 FOR C=1 TO 2 :CSAVE "PROGRAME"
:MOTORON :FOR X=1 TO 600 :NEXT :NEXT
:MOTOROFF
```

The advantage of this lies in the ease with which you save the program, which encourages more frequent saves when programming. All you do is set the recorder to record, type *GOTO 10000* and answer Y or N and *ENTER* to the *RUN PAST LEADER ?* question. It is probably time for another trip to the kitchen anyway, so take a short break.

In the *OPEN "1",-1,"FILENAME"* statement, the -1 is

### STAT'S

A STATISTICAL ANALYSIS PROGRAM, THAT CALCULATES-MEAN,--VARIANCE, AND STANDARD DEVIATION FOR BOTH SAMPLES OR POPULATION. ALLOWS DATA STORAGE TO TAPE OR DISK. FULL COLOR GRAPHING OF FREQUENCY HISTOGRAM. ALLOWS EASY MODIFICATION OF STORED DATA, COMBINE TWO FILES, ETC. USER FRIENDLY! CASSETTE \$24.95

---

### COLOR GRAPIC PRINTER UTILITES

UTILITES FOR RADIO SHACKS CGP-1115,COLOR GRAPIC PRINTER/PLOTTER WORD PROCESSOR--SUPPORTS IMBEDDED CONTROLS FOR PRINT SIZE AND COLOR RIGHT JUSTIFICATION. DESIGNED JUST FOR THE CGP-1115 SCREEN PRINT PROGRAM--TRUE FOUR COLOR PRINT OUT, WORKS IN MODE 3 OR 4 YOU WON'T BELIEVE THE DETAILS DRAWING BOARD---ETCH-A-SKETCH FOR THE PRINTER. ANY COLOR, EASY CORRECTIONS CASSETTE \$24.95

---

### RELOCATE

RELOCATE MAKES AUTOMATIC TAPE COPIES OF ANY COLOR COMPUTER CARTRIDGE. ALLOWS CHANGES TO BE MADE TO THE PROGRAM SUCH AS (PRINT-OUT BUIDEOTEX, CHANGE BAUD RATE IN ASCRIPSIT, ECT.) REQUIRES EITHER A 04K MOD. OR A 10K OR LARGER COMPUTER WITH A CARTRIDGE MEMORY EXPANSION OF 4K OR LARGER. VERY EASY TO USE! ONCE FAMILIAR WITH THE PROGRAM, COPIES CAN BE MADE IN LESS THEN FOUR MINUTES CASSETTE \$24.95

---

### COMPTERIZED ALARM SYSTEMS

LET CoCo WATCH YOUR HOUSE WHILE YOU ARE AWAY. LESS THAN TWENTY DOLLARS OF RADIO SHACK COMPONENTS. PLANS AND SOFTWARE. WRITE FOR DETAILS

(THIS AD TYPESET WITH THE COLOR GRAPIC PRINTER)

---

## TRANSTION TECHNOLOGY

1458 W. BIRCHWOOD AVE.  
CHICAGO IL 60626

\*1.50 SHIPPING AND HANDLING C.O.D. EXTRA

PLEASE SPECIFY SYSTEM 10K-MIN

\*TANDY Corp

**ADVENTURES**

16K CIRCUS ADVENTURE \$9.95  
A child's adventure game with many songs, graphics, and surprises. Meet all of your circus favorites while searching for the popcorn man. Great family fun for all ages.

16K SCHOOLMAZE ADVENTURE \$11.95  
While in search of a lost computer tape, you travel in a school and draw pictures, compose songs, play basketball, and use the keyboard to travel in the hallways.

**GAMES**

COCO-JOT by Steve Greenberg  
16K \$11.95  
A new version of the famous Jotto word game. A guessing game using your powers of reasoning and deduction. 1 or 2 player game. Different levels of play. Ages 8 to adult. User modifiable.

"FROG-MAN" by Carsten Lawrenz  
16K Ext. Basic \$11.95  
Lively, action packed, joystick controlled game. 7 levels of difficulty and timer. Best score displayed. Get your frogs safely home through several interesting obstacles.

\*\*\* NEW \*\*\*  
SOFTWARE FOR SPECTRUM'S LIGHT PEN  
KID'S FUN-PAK: This 3 program game set will entertain you with a great new dimension for your computer. Tutorial included with documentation.  
Kid's Fun-Pak Tape 16K Ext. \$14.95  
Light Pen and Tape \$34.95



**LEARNING PROGRAMS FOR HOME OR SCHOOL**

FOREIGN LANGUAGE GAMES 16K or 16K Ext. \$11.95  
FRENCH BASEBALL — Score base hits or home runs for correct answers. You're out if wrong. Correct answers supplied. Fun way to learn and practice vocabulary. 2 levels.  
SPANISH BASEBALL — Same game using Spanish vocabulary words.  
ITALIAN BASEBALL — Same game using Italian vocabulary words.  
User Modifiable.

**PLEASE SPECIFY LANGUAGE AND VERSION**

HEBREW BULLETIN BOARD 16K Ext. \$15.95  
by Joseph Kolar and Steve Blyn  
A utility that will enable YOU to create Hebrew or Hebrew/English words, flash cards, sentences, greeting cards, etc. in Hi-res. Easy to learn-full documentation. For hard copy, use your printer and any screen print program.

DOLLARS AND SENSE 16K Ext. \$11.95  
Learn to make purchases. Graphic displays of items kids love. Player buys using dollars and coins to practice using money correctly. Solutions given.

MCCOCO'S MENU 16K Ext. \$11.95  
America's favorite pastime — going out to eat! Learn to buy and add up your purchases from a typical fast food restaurant menu. Gain skill in using money. Different prices each time.

ADDITION AND SUBTRACTION 16K \$11.95  
Menu driven, 2 level program provides practice in adding or subtracting 2 digit numbers. Vertical format for proper entry of digits in the answers. Report card scoring.

READING 2-PAK 4K \$9.95  
POETRY and SILLY SENTENCES: Any child can create his own original reading material about familiar people and things through user input.

READING GAMES 2 Pack 4K \$9.95  
Silly Stories and Wizard: These games provide practice in reading simple stories and phrases. User input make these games personal and fun and keep your child interested in reading the results.

Computer Island Presents  
**THE BEST IN SOFTWARE FOR KIDS!**

\*\*\* SPECIAL CLOSEOUT \*\*\*  
\* Two never released hi-res. \*  
\* machine language 2-player, \*  
\* joystick, arcade games from \*  
\* Creative Computing. \*  
\* 1. PICNIC- Escape the evil \*  
\* spider and capture foods. \*  
\* 2. TRICKASHAY- A tank duel \*  
\* in a tricky maze. \*  
\* 16- K Extended \*  
\* Both for an incredibly \*  
\* low price of \$11.95 \*  
\*\*\*\*\*

COMPUTER ISLAND  
DEPT. R  
227 Hampton Green  
Staten Island, N.Y. 10312

(212) 948-2748



**BOOK**

**A BYTE OF COLOR BASIC**  
by Steve Blyn

A work-text containing — instruction, examples, illustrations, programs, and many practice exercises. 3 Units — Basic, Graphics, and Sound. 24 chapters to teach you what you need to know to begin reading, understanding, and writing your own programs. Answer Key included with each book. Great book for beginners.

\$4.95 NEW LOW PRICE  
SCHOOL DISCOUNTS

**MUSIC**



**NAME THAT SONG GAMES**

16K Extended \$9.95 each  
1. 72 children's popular songs. 2 levels of difficulty. Timer. Many hours of fun.  
2. 72 all time pop, country, and movie melodies from the last three decades.  
3. 60 Broadway Show tunes to test you on past musicals. Fun for all trivia buffs.

FREE set of BINARY DICE including full directions when ordering any 2 items !!!

DEALERS INQUIRIES INVITED  
N.Y. Residents, please add proper tax  
Please add \$1.00 per order for postage

**PRESCHOOL**

PRESCHOOL PACK 1 by Joseph Kolar  
16K Ext. \$11.95  
Clown and Fish-Num: Two programs to help your child recognize and count the words and numbers 1 - 10. Hi-res graphics and lively songs help to attract and keep attention.

PRESCHOOL PACK 2 by Joseph Kolar  
16K Ext. \$11.95  
Count Kids and Add Penny: Two programs to help your child count and add up to 10. Beautiful hi-res graphics.

PRESCHOOL PACK 3 by Joseph Kolar  
16K Ext. \$11.95  
Alpha-Byte: Programs designed to teach recognition and identification of the alphabet. Attractive hi-res graphics.

MUSIC MARVEL 16K Ext. Basic \$9.95  
Play 2 familiar children's songs. Large graphic displays. No reading or musical ability needed. Great for pre-schoolers. 16K version also available. Please specify.

Authors: We are seeking quality children's software for leisure or learning. Write for details. Top royalties.



the device number. It tells the computer which buffer to use and where to send the buffer when full. If you had a disk, you would use a device number from +1 to +15. With the disk, you can have a number of disk buffers open at once along with a cassette file open. In this situation, files are closed by number and there seem to be some tricks on order of opening and closing. More on this after I have direct experience with a disk system. You can substitute a variable for the device number. This allows you to put code in to choose whether you want a sequential file to go to disk or to tape. The filename generally is a variable with code to allow the user to enter the file name to be saved and the name of the file to be loaded.

Cassette files are limited to sequential files where data is put to tape in sequence and must be accessed in the same sequence. Disks support sequential files, but can handle random files as well. For example, records can be saved individually to disk in random order and then individually retrieved in random order. In this way, large data bases are essentially on line with the program though little of the data is in memory at any one time. Typically, business programs require this type of storage to accommodate large data bases. I expect to see random access disk programs for CoCo as more users decide that their machine should be doing more for them than playing games.

Here is a good 'homework' problem you might want to tackle: Take one of your programs that saves a data file and convert it to have a run-past-leader option, and save twice. Note the `MOTORON :FOR X=1 TO 600 :NEXT` that leaves a little space between saves and at the end. If you haven't written a program using data files yet, wouldn't that be a neat next project? ☺

Hardware Review . . .

## Panostyk Is A Boon To All You Frustrated Artists

I admit that I was somewhat skeptical of the *Panostyk* when it arrived the other day. It is unimposing-looking, with a sort of wooden board, an accordion-like bunch of metal rods and what appears to be a Radio Shack joystick tucked into a box on the bottom.

Looks can deceive.

What the *Panostyk* is happens to be a nice way to get pictures from paper to the graphic screen. Now, you can do this with Radio Shack's X-Pad, but the *Panostyk* is much less expensive.

The *Panostyk* comes complete with software, which—from a menu—allows you to use either a "sketch," "crayon" or "chalk" mode. The difference between them is primarily one of degree, but we felt that each offered a different type of drawing opportunity.

The "sketch" mode uses the high resolution graphics screen and is for drawing pictures in fine detail. Using a clear plastic circle with a small hole in it (suitable for inserting a thin pencil lead) you simply place a drawing under a plastic cover and then trace it. A good representation of what you have traced appears on the CoCo screen. Since "sketch" is in high resolution, you can get some nice drawings this way.

"Crayon" mode works in much the same way, except it uses the four-color mode to make colored lines. "Chalk" uses the low-res graphics, and all eight colors, which is very suitable for younger children, as well as those of us who do not draw too well.

The software includes an easy circle-drawing routine and color one is always an "eraser." In addition, you can "lift" the drawing pencil up from the "screen" by pressing a red button on the *Panostyk*. You can also "paint" in areas with a single button-press.

I suspect those of you who are adept at art—such as Paul Hoffman, who has contributed some fabulous programs to the *Rainbow*—would much prefer the possibilities created by the X-Pad. But, for those of us who only look at what the likes of Paul do and wish, the *Panostyk* is an excellent way to try to transfer some of the things we see on paper onto the CoCo screen.

It is easy to use and comes with a well done software package which, for all intents and purposes, is invisible to the user. You just load the software, select the drawing mode you want, and concentrate on your artwork. And, for children, I believe that the "chalk" mode is an excellent way for them to have fun with the computer without frustrating them.

In addition to the *Panostyk* itself and the software, the package comes with several sample drawings, with markings for colors, circle points and the like. These are good to experiment with and are useful in getting the feel of the hardware.

(Spectrum Projects, 93-15 86th Drive, Woodhaven, NY 11421, \$79.95)

—Lawrence C. Falk

## MORETON BAY SOFTWARE

For TRS 80 Color Computer & TDP 100

**PLANETARIUM** - a five program astronomy package. See constellations, stars, moon and planets 16K extended \$16.95.

**CUBE SOLVER** - a highly graphic ML program. Technically interesting: Program will: solve cube on screen, mix it up, print solutions to screen, tape or printer. 16K extended \$19.95

**TOWER CASTLE** - a classic thematic adventure with music and color, tough but honest (Reviewed December 1982 *Rainbow*) 32K extended \$17.95

Moreton Bay



Software

TRS 80 © Tandy Corp.

**MORETON BAY SOFTWARE**

A DIVISION OF MORETON BAY LABORATORY

316 Castillo Street  
Santa Barbara, CA 93101  
(805) 962-3127

CA Residents Add 6% Sales Tax



# Telewriter-64™

## the Color Computer Word Processor

- 3 display formats: 51/64/85 columns × 24 lines
- True lower case characters
- User-friendly full-screen editor
- Right justification
- Easy hyphenation
- Drives any printer
- Embedded format and control codes
- Runs in 16K, 32K, or 64K
- Menu-driven disk and cassette I/O
- No hardware modifications required

### THE ORIGINAL

Simply stated, Telewriter is the most powerful word processor you can buy for the TRS-80 Color Computer. The original Telewriter has received rave reviews in every major Color Computer and TRS-80 magazine, as well as enthusiastic praise from thousands of satisfied owners. And rightly so.

The standard Color Computer display of 32 characters by 16 lines without lower case is simply inadequate for serious word processing. The checkerboard letters and tiny lines give you no feel for how your writing looks or reads. Telewriter gives the Color Computer a 51 column by 24 line screen display with *true lower case characters*. So a Telewriter screen looks like a printed page, with a good chunk of text on screen at one time. In fact, more on screen text than you'd get with Apple II, Atari, TI, Vic or TRS-80 Model III.

On top of that, the sophisticated Telewriter full-screen editor is so simple to use, it makes writing fun. With single-letter mnemonic commands, and menu-driven I/O and formatting, Telewriter surpasses all others for user friendliness and pure power.

Telewriter's chain printing feature means that the size of your text is never limited by the amount of memory you have, and Telewriter's advanced cassette handler gives you a powerful word processor without the major additional cost of a disk.

...one of the best programs for the Color Computer I have seen...

— Color Computer News, Jan. 1982

### TELEWRITER-64

But now we've added more power to Telewriter. Not just bells and whistles, but major features that give you total control over your writing. We call this new supercharged version Telewriter-64. For two reasons.

### 64K COMPATIBLE

Telewriter-64 runs fully in any Color Computer — 16K, 32K, or 64K, with or without Extended Basic, with disk or cassette or both. It automatically configures itself to take optimum advantage of all available memory. That means that when you upgrade your memory, the Telewriter-64 text buffer grows accordingly. In a 64K cassette based system, for example, you get about 40K of memory to store text. So you don't need disk or FLEX to put all your 64K to work immediately.

### 64 COLUMNS (AND 85!)

Besides the original 51 column screen, Telewriter-64 now gives you 2 additional high-density displays: 64 × 24 and 85 × 24!! Both high density modes provide all the standard Telewriter editing capabilities, and you can switch instantly to any of the 3 formats with a single control key command.

The 51 × 24 display is clear and crisp on the screen. The two high density modes are more crowded and less easily readable, but they are perfect for showing you the exact layout of your printed page, *all on the screen at one time*. Compare this with cumbersome "windows" that show you only fragments at a time and don't even allow editing.

### RIGHT JUSTIFICATION & HYPHENATION

One outstanding advantage of the full-width screen display is that you can now set the screen width to match the width of your printed page, so that "what you see is what you get." This makes exact alignment of columns possible and it makes hyphenation simple.

Since short lines are the reason for the large spaces often found in standard right justified text, and since hyphenation is the most effective way to eliminate short lines, Telewriter-64 can now promise you some of the best looking right justification you can get on the Color Computer.

### FEATURES & SPECIFICATIONS:

**Printing and formatting:** Drives any printer (LPVII/VIII, DMP-100/200, Epson, Okidata, Centronics, NEC, C. Itoh, Smith-Corona, Terminus, etc).

Embedded control codes give full dynamic access to intelligent printer features like: underlining, subscript, superscript, variable font and type size, dot-graphics, etc.

Dynamic (embedded) format controls for: top, bottom, and left margins; line length, lines per page, line spacing, new page, change page numbering, conditional new page, enable/disable justification.

Menu-driven control of these parameters, as well as: pause at page bottom, page numbering, baud rate (so you can run your printer at top speed), and Epson font. "Typewriter" feature sends typed lines directly to your printer, and Direct mode sends control codes right from the keyboard. Special Epson driver simplifies use with MX-80.

Supports single and multi-line headers and automatic centering. Print or save all or any section of the text buffer. Chain print any number of files from cassette or disk.

**File and I/O Features:** ASCII format files — create and edit BASIC, Assembly, Pascal, and C programs, Smart Terminal files (for uploading or downloading), even text files from other word processors. Compatible with spelling checkers (like Spell 'n Fix).

Cassette verify command for sure saves. Cassette auto-retry means you type a load command only once no matter where you are in the tape.

Read in, save, partial save, and append files with disk and/or cassette. For disk: print directory with free space to screen or printer, kill and rename files, set default drive. Easily customized to the number of drives in the system.

**Editing features:** Fast, full-screen editor with wordwrap, block copy, block move, block delete, line delete, global search and replace (or delete), wild card search, fast auto-repeat cursor, fast scrolling, cursor up, down, right, left, begin line, end line, top of text, bottom of text; page forward, page backward, align text, tabs, choice of buff or green background, complete error protection, line counter, word counter, space left, current file name, default drive in effect, set line length on screen.

Insert or delete text anywhere on the screen without changing "modes." This fast "free-form" editor provides maximum ease of use. Everything you do appears immediately on the screen in front of you. Commands require only a single key or a single key plus CLEAR.

...truly a state of the art word processor...  
outstanding in every respect.

— The RAINBOW, Jan. 1982

### PROFESSIONAL WORD PROCESSING

You can no longer afford to be without the power and efficiency word processing brings to everything you write. The TRS-80 Color Computer is the lowest priced micro with the capability for serious word processing. And only Telewriter-64 fully unleashes that capability.

Telewriter-64 costs \$49.95 on cassette, \$59.95 on disk, and comes complete with over 70 pages of well-written documentation. (The step-by-step tutorial will have your writing with Telewriter-64 in a matter of minutes.)

To order, send check or money order to:

Cognitex  
704 Nob Street  
Del Mar, CA 92014

Or check your local software store. If you have questions, or would like to order by Visa or Mastercard, call us at (619) 755-1258 (weekdays, 8AM-4PM PST). Dealer inquiries invited.

(Add \$2 for shipping. Californians add 6% state tax. Allow 2 weeks for personal checks. Send self-addressed stamped envelope for Telewriter reviews from CEN, RAINBOW, 80-Micro, 80-U.S. Telewriter owners: send SASE or call for information on upgrading to Telewriter-64. Telewriter-compatible spelling checker (Spell 'n Fix) and Smart Terminal program (Colorcom/E) also available. Call or write for more information.)

Apple II is a trademark of Apple Computer, Inc.; Atari is a trademark of Atari, Inc.; TRS-80 is a trademark of Tandy Corp; MX-80 is a trademark of Epson America, Inc.



# RAINBOW Info

## What's A CoCo

CoCo is an affectionate name which was first given to the TRS-80 Color Computer by its many fans, users and owners. As such, it is almost a generic term for three computers, all of which are very much alike.

When we use the term CoCo, we refer to the TRS-80 Color Computer, the TDP System-100 Computer and the Dragon-32 Computer. It is easier than using the three "given" names throughout *the Rainbow*.

In most cases, when a specific computer is mentioned, the application is for that specific computer. However, since the TDP System-100 and TRS-80 Color are, for all purposes, the same computer in a different case, these terms are almost always interchangeable.



## The Rainbow Seal

The Rainbow Certification Seal is our way of helping you, the consumer. The purpose of the Seal is to certify to you that any product which carries the Seal has been physically seen by us and that it does, indeed, exist.

Manufacturers of products — hardware, software and firmware — are encouraged by us to submit their products to *the Rainbow* for certification. We ascertain that their products are, in actuality, what they purport to be and, upon such determination, award a Seal. This lets you know that we have seen the product and that it does, indeed, exist.

The Seal, however, is not a "guarantee of satisfaction." The certification process is different from the review process. You are encouraged to read our reviews to determine whether the product is right for your needs.

There is absolutely no relationship between advertising in *the Rainbow* and the certification process. Certification is open and available to any product pertaining to CoCo. A Seal will be awarded to *any* commercial product, regardless of whether the firm advertises or not.

We will appreciate knowing of instances of violation of Seal use.

## Using Machine Language

Machine Language programs are one of the features of *the Rainbow*. There are a number of ways to "get" these programs into memory so that you can operate them.

The easiest way is by using an Editor-Assembler, a program you can purchase from a number of sources.

An editor-assembler allows you to enter mnemonics into your CoCo and then have the editor-assembler assemble them into specific instructions that are understood by the 6809 chip that controls your computer.

When you use an editor-assembler, all you have to do, essentially, is copy the relevant instructions from *the Rainbow's* listing into CoCo.

Another method of getting an assembly language listing into CoCo is called "hand assembly." As the name implies, you do the assembly by hand. This can *sometimes* cause problems when you have to set up an ORIGIN statement or an EQUATE. In short, you have to know something about assembly to hand assemble some programs.

Use the following program if you wish to hand assemble machine language listings:

```
10 CLEAR200,&H3F00:I=&H3F80
20 PRINT "ADDRESS:";HEX$(I);
30 INPUT "BYTE";B$
40 POKE I,VAL("&H"+B$)
50 I=I+1:GOTO 20
```

This program assumes you have a 16K CoCo. If you have 32K, change the &H3F00 in Line 10 to &H7F00.

## Changing Issue Dates

We will be "skipping" a cover date—but **not** issue of *the Rainbow* with the May issue this year.

You will still get 12 issues in each subscription. The change just means that you will get an issue "earlier" than it has been coming. This starts with the June issue—which will arrive at about the time that the May issue would normally arrive, or about a month early.

What this means is that next month's issue will be dated June. All subscription expiration dates will be changed to take this adjustment into consideration.

A full explanation is on page 79 of this month's issue.

## The Rainbow Check

The small boxes which you see with programs in *the Rainbow* are our *RAINBOW CHECK* program, which is designed to help you type in programs accurately.

The check program itself is a machine language program which will count the number of characters you type in. You can then compare the number the *RAINBOW CHECK* gives you to those printed in *the Rainbow*. On longer programs, some benchmark lines are given. When you reach the end of one of those lines with your typing, simply check to see if the numbers match.

To use the *RAINBOW CHECK*, type in *CLEAR 25, 16303* (or *CLEAR 25, 32687* for 32K) and *CSAVE* the program that follows. Then type in the command *EXEC* and press *ENTER*.

Now, whenever you press the down arrow, CoCo will give you the hexadecimal number of bytes in memory. This is to check against the numbers printed in *the Rainbow*. If your number is different, check the listing carefully to be sure you typed in the proper BASIC program code.

Type in programs *exactly* as you see them printed in *the Rainbow*. All BASIC listings are printed out 32 characters wide, conforming exactly to the CoCo screen display. Because the *RAINBOW CHECK* counts spaces, too, you should follow the spacing just as it appears in the magazine.

Here's the program:

```
10 CLS:IF PEEK(116)=127 THEN
X=32688 ELSE X=16304
20 CLEAR 25,X-1
30 IF PEEK(116)=127 THEN X=32688
ELSE X=16304
40 FOR Z=X TO X+77
50 READ Y:W=W+Y:PRINT Z,Y;W
60 POKE Z,Y:NEXT
70 IF W=5718 THEN 80 ELSE PRINT
"DATA ERROR":STOP
80 EXEC X:END
90 DATA 182, 1, 106, 167, 141, 0, 68
100 DATA 134, 126, 183, 1, 106, 190
110 DATA 1, 107, 175, 141, 0, 57, 48
120 DATA 141, 0, 4, 191, 1, 107, 57
130 DATA 129, 10, 38, 44, 52, 22, 220
140 DATA 27, 147, 25, 142, 4, 0, 141
150 DATA 6, 31, 152, 141, 2, 32, 25
160 DATA 52, 2, 68, 68, 68, 68
170 DATA 141, 4, 53, 2, 132
180 DATA 15, 129, 9, 46, 4, 139, 112
190 DATA 32, 2, 139, 55, 167, 128, 57
200 52, 22, 126, 0, 0
```

## **"TRS-80 COLOR COMPUTER PRODUCTS"** **"THE 1248-EP EPROM PROGRAMMER"**

The 1248-EP EPROM PROGRAMMER is a full function unit that is compatible with virtually all popular 1K, 2K, 4K & 8K -by-8, 24 pin, 5 volt EPROMS. Compatible devices are 2508's, 2758 -0/1's, 2516's, 2716's, 2532's, 68732-0/1's, 68764's, and 68766's. Components 2732, 2732A, 2564, and 2764 are compatible via adapters (not supplied). The programmer is totally menu driven by resident position independent firmware in EPROM, which makes it suitable for experienced computer operators and novices alike.

Select the device type to be programmed from the device menu. Next, select the function to be performed from the function menu. On your command the 1248-EP will verify EPROM erasure, compare EPROM contents to specified contents of RAM or ROM, program blocks or individual bytes of EPROM memory or copy an EPROM's contents to user specified RAM.

The 1248-EP plugs into the cartridge slot of the Color Computer and is invoked by the user with the "EXEC & HCOOO" BASIC command. The 1248-EP contains its own on-board programming power supply, and has a quality "Zero Insertion Force" socket.

The combination of the TRS-80 Color Computer, an editor/assembler/monitor such as the Micro Works SDS80C\*:\* and the 1248-EP EPROM programmer, makes a high performance, cost effective software development station for MC-6800/6809 microprocessor based systems. Use the system to store your own games or utility programs in EPROM's for execution from the cartridge slot using the CK4 PROM/RAM card described below.

The cost of the 1248-EP EPROM PROGRAMMER, instructions and adapter diagrams is just \$99.95.

### **"THE CK4 PROM/ROM CARD"**

The CK4 works with 2K, 4K or 8K-by-8 ROM's or EPROM's of the 5 volt only variety in 24 pin packages. In addition, the CK4 may be used with 4 static RAM's such as 6116's to expand the computers memory work space by 8192 bytes. Each of the four on-board sockets can be decoded to any 2K block of the memory map from \$C000 through \$F800 of the Color Computer. In addition, each socket can be configured to respond to address blocks from 2K to 8K bytes in length, thus accommodating 2K, 4K or 8K-by-8 ROM's, EPROM's or RAM's. ROM and RAM can be mixed on the card as well. RAM, on the card, can be written to and then "write protected" via dip switches on the CK4 to emulate ROM.

The instructions include information on how to set up the socket decoding circuitry and how to provide battery backup for programs stored in CMOS static RAM on the CK4 with the computer off or the cartridge removed.

The popular CK4 PROM/RAM card is now available in three versions.

1) The full featured CK4 remains the standard of cartridge board flexibility with the added capability of providing battery backup for CMOS static RAM's such as 6116's. Cost of the CK4 is still just \$29.95.

2) The CK4-1 is a ROM only version of the CK4 card for use with CoCo's with later than "E series" circuit boards. These later versions of CoCo are not able to write to cartridge based RAM without modification. Cost is \$27.95 for the CK4-1.

3) The CK4-2 is the unpopulated CK4 series circuit board only. Buy this version of the CK4 and configure them to meet your specific requirements at a price designed to stretch your dollars value. Cost is \$15.95 each.

### **"MORSE ENCODER/DECODER KIT"**

The MEDK80 Morse En/Decoder Kit consists of a machine code software driver on tape, a schematic diagram of the interface circuitry, component parts, a printed circuit board (PCB), packaging suggestions and complete instructions for building a Morse code transmission and reception system that is compatible with 4K RAM and up models of the TRS-80 Color Computer.

The transmitter/receiver interface circuitry is totally optically isolated and is, therefore, compatible with all receivers and transmitters. Transmitter and receiver both connect to the interface unit and to the Color Computer via the RS-232 port.

The MEDK80 Morse En/Decoder kit operates at speeds up to 70 words per minute and automatically adapts to speed variations of the sender. When transmitting, words are transmitted only when fully formed, i.e., followed by a space, and the transmit text buffer gives visual notification to the operator of what word/character is currently being sent. In addition, the text buffer is 512 characters deep, which is sufficiently large to keep up with the best of "rag-chewers".

Potential purchasers of this product should have previous kit building experience. However, this is not a kit of great complexity, and is well within the abilities of those actively involved in amateur radio or electronic hobbies to construct. To reduce the chance of wiring errors, component placement is indicated on the PCB and detailed assembly instructions are included.

The cost of the MEDK80 software, parts, and instructions is \$39.95.

### **"COCO" GETS A BREADBOARD**

The COCO BREADBOARD is a circuit board that plugs directly into the cartridge slot of the Color Computer and provides the user with 16 square inches of predrilled breadboarding area for circuit development, interfacing experiments, motherboard implementation, or whatever your imagination conjures up. The plated thru holes in the breadboard are wirewrap pin compatible and on 0.10 inch centers.

The COCO BREAD BOARD brings all of the data, address, and control signals available at the cartridge slot outside of the body of the computer and the signal lines are appropriately labeled to facilitate error free wiring of breadboards. A ground plane is provided on the top side of the board and solder pads are provided on the bottom of the board, thus facilitating circuit grounding and point-to-point wiring. In short, the COCO BREADBOARD was designed with the experimenter in mind.

The COCO BREADBOARD is attractively priced to justify its use for even the lowest budget projects. It is an ideal vehicle for learning interfacing techniques. Buy extras to have on hand for those rainy weekends.

The COCO BREADBOARD costs just \$19.95. Price for two (2) or more is \$16.95 each.

### **FACTORY FRESH COMPONENTS:**

ITEM	DESCRIPTION	PRICE
2716 EPROM	2K by 8 bit, 350 ns	\$4.50 ea.
2532 EPROM	4K by 8 bit, 350 ns	\$6.50 ea.
6821P	P.I.A.	\$3.50 ea.
74LS156	Open collector decoder	\$1.70 ea.
Socket	ZIF, 24 pin, Aries	\$7.95 ea.

Minimum component order: \$25.00

### **ORDERING INFORMATION:**

Add \$3.00 to all orders to cover shipping and handling. Allow two weeks for personal checks. Canadian residents add 5% to cover special handling. Arizona residents add 4% sales tax. Sorry! No charges accepted. All items shipped UPS.

Make checks payable to:

**COMPUTER ACCESSORIES OF ARIZONA**  
**5801 E. VOLTAIRE DRIVE**  
**SCOTTSDALE, ARIZONA 85254**  
**(602) 996-7569**

\* TRS-80 is a trademark of TANDY CORP.  
\*\* SDS80C is a trademark of the MICRO WORKS.  
Prices subject to change without notice.



# CoCo Says Repeat This Tune

By Larry Konecky  
Director CAI In Music  
Alcorn State University

Computer Assisted Instruction (CAI) is receiving much attention in all areas of education, particularly in subject areas where drill and practice exercises are necessary for student learning. In music education, ear training is an area in which much practice is necessary by many students for sufficient development to occur. Also, even though students may be in the same music theory classes, or at the same performing levels, their aural discrimination skills may vary greatly. For this reason programs which relate to various skill levels are necessary.

The following musical game is intended to give students practice in aural note identification at various skill levels. A piano keyboard is displayed on the screen upon which the computer plays sequences of notes which students must repeat by pressing the proper keys on the Color Computer. Since the computer keyboard is not like the piano keyboard some imagination is necessary to visualize the piano keyboard onto the Color Computer keyboard. A plastic overlay can be helpful by marking on the overlay the bottom row of keys ('Z', 'X', 'C', 'V', 'B', 'N', 'M', and ',') as piano white keys and in the next row ('S', 'D', 'G', 'H', and 'J') as black keys. Also relabeling the computer keys their respective piano key names (middle C through C above middle C) can be helpful.

At each novice level the computer shows which notes are being played as well as sounding them before asking students to repeat the sequence. In each other level only the first note is shown, forcing the player to rely on listening ability alone. The game begins with a one note sequence which is lengthened by one note after each successful completion of up to a maximum of fifty notes. This level can be changed by adjusting lines 10 and 755.

At the intermediate-diatonic level, the intervals between successive notes are limited to a maximum distance of a fifth. At the intermediate-chromatic level, the randomize function is set so that a greater amount of white key notes will occur than black key notes. In other levels the notes have an equal chance of being selected.

You may want to change the comments given at the end of each exercise or the levels at which they occur. Refer to program lines 1300 through 1460 to make the desired changes.

Statement 5 uses a *PCLEAR 1* which will give a syntax error the first time the program is *RUN* after it is loaded. Just retype *RUN*, press *ENTER* and the program will run without the syntax error.

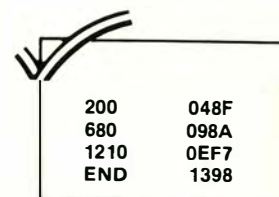

200	048F
680	098A
1210	0EF7
END	1398

The listing:

```

5 PCLEAR 1
10 DIM M(50), T(13)
14 '*****
15 '** note table **
16 '*****
20 FORB=1TO13:READT(B):NEXT
30 DATA 89,108,125,133,147,159,1
70,176
40 DATA 99,117,140,153,165
44 '*****
45 '** keyboard graphics **
46 '*****
50 W$=CHR$(207):WL$=CHR$(202):WR
$=CHR$(197):W2$=W$+W$:W3$=W$+W2$
:B$=CHR$(128):V$=CHR$(175)
60 C$=W2$+WL$+B$+WR$+W$+WL$+B$+W
R$+W2$:D$=W3$+V$+W3$+V$+W3$
70 F$=W2$+WL$+B$+WR$+W$+WL$+B$+W
    
```

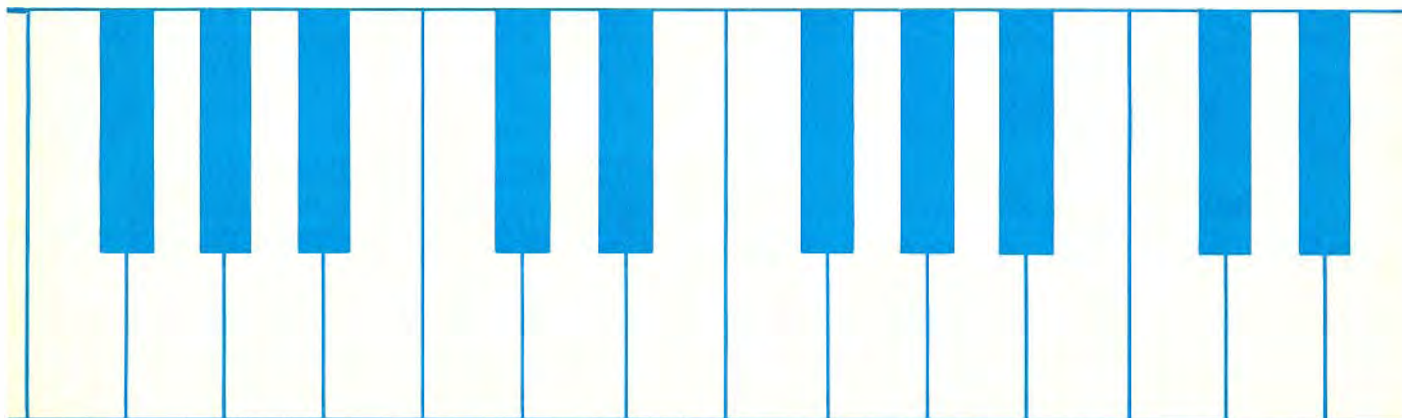

```

R$+W$+WL$+B$+WR$+W2$:G$=W3$+V$+W
3$+V$+W3$+V$+W3$:H$=W2$+WL$
80 Y$=CHR$(159):R$=CHR$(255):GR$
=CHR$(223)
89 '*****
90 '** introduction page **
91 '*****
100 CLS0:PRINT@10,"*SIMON SAYS*"
;
110 PRINT@40,"*PLAY THIS TUNE*";
120 PRINT@96," A TUNE WILL BE DE
VELOPED ONE NOTE AT A TIME. Y
OU ARE TO CORRECTLY PLAY BA
CK THE TUNE BY PRESSING THE C
ORRECT KEYS."
130 PRINT@256," YOU MUST ANSWER
QUICKLY!"
140 PRINT@326," ENTER YOUR NAME
: ";:PRINT@352,;:INPUTN$
150 PRINT@450," PRESS K FOR KEYB
OARD SETUP ";
160 PRINT@485," PRESS C TO CONTI
NUE ";
170 K$=INKEY$:M(1)=RND(13):IFK$=
""THEN170
180 IFK$="K"THENC=1:GOTO196
190 IFK$="C"THENC=0:GOTO200
195 GOTO170
196 GOSUB800
197 '*****
198 '** level select **
199 '*****
200 CLS4
210 PRINT@10,"*SIMON SAYS*";
220 PRINT@40,"*PLAY THIS TUNE*";
230 PRINT@96," SELECT FROM THE F
OLLOWING:";
240 PRINT@163," 1) NOVICE -- DI
ATONIC ";
245 PRINT@195," 2) INTERMED -- DI
ATONIC ";
250 PRINT@227," 3) EXPERT -- DI

```

```

ATONIC ";
255 PRINT@259," 4) NOVICE -- CH
ROMATIC ";
260 PRINT@291," 5) INTERMED -- CH
ROMATIC ";
265 PRINT@323," 6) EXPERT -- CH
ROMATIC ";
280 PRINT@122,;:INPUTR
290 IFR<10RR>6THEN230
360 IFC=1THENC=0
370 GOSUB800
380 X=1
389 '*****
390 '** computer note select **
391 '*****
400 PRINT@38,STRING$(20,159);
410 PRINT@70,Y$+Y$+Y$+Y$"***LIST
EN***"Y$+Y$+Y$+Y$;
420 PRINT@102,STRING$(20,159);
430 IFR<4THENM(X)=RND(8)ELSEM(X)
=RND(13)
432 IFX>1ANDR=2THENGOSUB1500
433 IFX>1ANDR=5THENGOSUB1550
435 FORZ=1TO960:NEXT
440 FORY=1TOX
450 IFX=10RR=10RR=4THEN460ELSE47
0
460 GOSUB1000
470 SOUNDT(M(Y)),8
480 IFX=10RR=10RR=4THEN490ELSE49
5
490 GOSUB1050
495 NEXTY
497 '*****
498 '** answer select **
499 '*****
500 PRINT@38,STRING$(20,223);
510 PRINT@70,GR$+GR$;"***PLAY BA
CK!***"GR$+GR$;
520 PRINT@102,STRING$(20,223);
530 FORY=1TOX
540 T=1

```

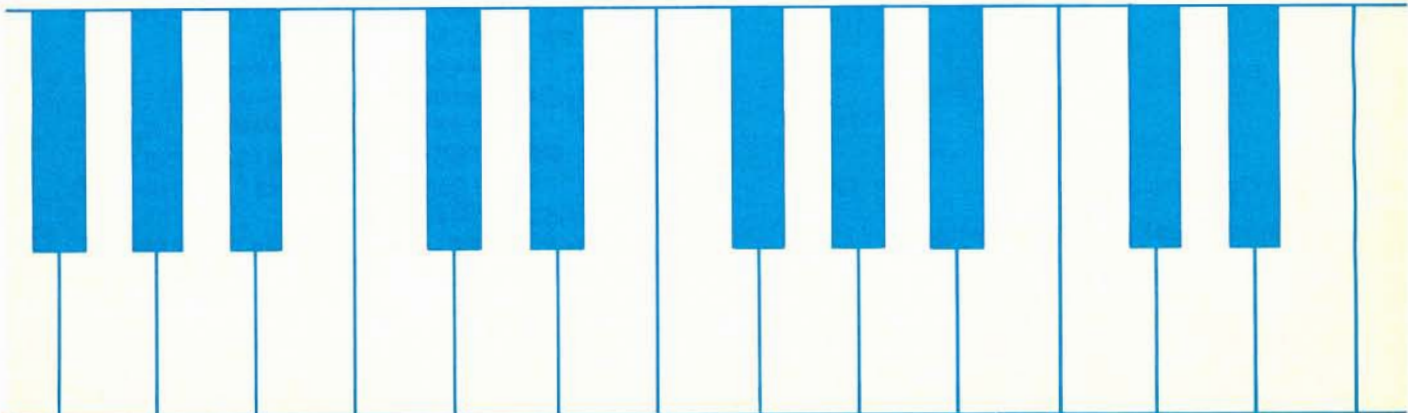

```

550 K$=INKEY$:T=T+1:IFT>250THEN1
200
560 IFK$=""THEN550
570 IFK$="Z"THENK=1:GOTO700
580 IFK$="X"THENK=2:GOTO700
590 IFK$="C"THENK=3:GOTO700
600 IFK$="V"THENK=4:GOTO700
610 IFK$="B"THENK=5:GOTO700
620 IFK$="N"THENK=6:GOTO700
630 IFK$="M"THENK=7:GOTO700
640 IFK$=","THENK=8:GOTO700
650 IFK$="S"THENK=9:GOTO700
660 IFK$="D"THENK=10:GOTO700
670 IFK$="G"THENK=11:GOTO700
680 IFK$="H"THENK=12:GOTO700
690 IFK$="J"THENK=13
700 IFM(Y)=K THEN710ELSE1200
710 GOSUB1000
720 SOUND T(K),7
730 GOSUB1050
740 NEXT Y
750 X=X+1
755 IFX=51THEN1600
760 GOTO400
797 '*****
798 '** print piano keyboard **
799 '*****
800 CLS3

```

```

810 PRINT@10,"*SIMON SAYS*";
820 PRINT@40,"*PLAY THIS TUNE*";
840 FORX=1TO4:Y=X*32+129:Z=X*32+
257
850 PRINT@Y,C$;:PRINT@Y+12,F$;:P
RINT@Y+28,H$;
860 PRINT@Z,D$;:PRINT@Z+12,G$;:P
RINT@Z+28,W3$;:NEXT
870 IFC=1THENGOSUB900
880 RETURN
897 '*****
898 '** computer keyboard **
899 '*****
900 PRINT@100," COMPUTER KEYBOAR
D SETUP ";
910 PRINT@228,"S";:PRINT@232,"D"
;:PRINT@240,"G";:PRINT@244,"H";:
PRINT@248,"J";
920 PRINT@354,"Z";:PRINT@358,"X"
;:PRINT@362,"C";:PRINT@366,"V";:
PRINT@370,"B";:PRINT@374,"N";:PR
INT@378,"M";:PRINT@382,",";
930 PRINT@485," PRESS C TO CONTI
NUE ";
940 K$=INKEY$:IFK$=""THEN940
950 IFK$="C"THEN RETURNELSE940
989 '*****
990 '** notes being played **
991 '*****
1000 IF M(Y)>10THEN1040
1010 IF M(Y)>8THEN1030
1020 PRINT@M(Y)*4+318,R$;:PRINT@
M(Y)*4+350,R$;:RETURN
1030 PRINT@M(Y)*4+160,R$;:PRINT@
M(Y)*4+192,R$;:RETURN
1040 PRINT@M(Y)*4+164,R$;:PRINT@
M(Y)*4+196,R$;:RETURN
1047 '*****
1048 '** return keyboard **
1049 '*****
1050 IFM(Y)>10THEN1090
1060 IFM(Y)>8THEN1080
1070 PRINT@M(Y)*4+318,W$;:PRINT@
M(Y)*4+350,W$;:RETURN
1080 PRINT@M(Y)*4+160,B$;:PRINT@
M(Y)*4+192,B$;:RETURN
1090 PRINT@M(Y)*4+164,B$;:PRINT@
M(Y)*4+196,B$;:RETURN
1197 '*****
1198 '** wrong answer **
1199 '*****
1200 PRINT@36,STRING$(24,255);
1210 PRINT@68,R$+R$+R$ THAT NO
TE WAS: "R$+R$+R$";
1220 PRINT@100,STRING$(24,255);
1240 FORZ=1TO10
1250 GOSUB1000
1260 SOUND T(M(Y)),1
1270 GOSUB 1050
1280 SOUND T(M(Y)),1

```

**NEW** from  
**CoCoHut** 

THE ULTIMATE STRATEGY GAME

**ZARCONIAN  
MARBLE**

1 or 2  
*players*

16K Ext.  
*Basic  
required*

Cassette \$19.95      Disk \$24.95

Send check or money order to:  
**COCO HUT**  
P. O. Box 24451  
Houston, TX 77015



RAINBOW CONNECTION SOFTWARE presents...



5 soundational, colorful, graphic games for your Color Computer including: Brickout, B-17 Bomber, Blackjack, Jackpot and Computration - all for the price you might expect to pay for just one of these games!!! Plus added bonus - Compumind: guess the computer's secret code from clues provided - a game of logic for the whole family. At this price can your library afford to be without them?

All machines - Ext. Basic NOT Required  
\$19.95 Cassette - \$24.95 Disk

RAINBOW CONNECTION SOFTWARE presents...

# STAR WARS CHALLENGE

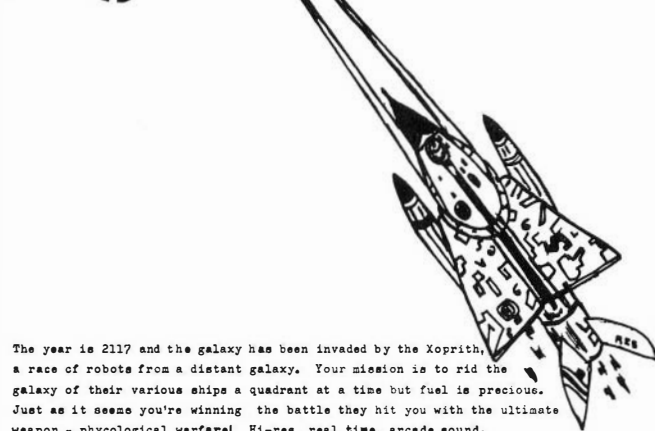

The year is 2117 and the galaxy has been invaded by the Xoprith, a race of robots from a distant galaxy. Your mission is to rid the galaxy of their various ships a quadrant at a time but fuel is precious. Just as it seems you're winning the battle they hit you with the ultimate weapon - phycological warfare! Hi-ree, real time, arcade sound.

16K Ext. Basic & Joystick  
\$14.95 Cass

RAINBOW CONNECTION SOFTWARE presents...

# CONQUEST OF KZIRGLA



You've traversed the dungeons of Kzirglia and reclaimed the almighty Scepter. Now you must use its invincible powers and all your weapons to slay a myriad of monsters and fireballs in your attempt to destroy the evil wizard. If you like the challenge and mystique but not the boredom of text only adventure games then this real time, hi-ree sequel to the ever popular Scepter of Kzirglia is for you!

CONQUEST OF KZIRGLA for the Color Computer

16K Ext. Basic Cass - \$21.95  
32K Diskette - \$26.95

# SCEPTER OF KZIRGLA



RAINBOW CONNECTION SOFTWARE presents...



At last...a real-time graphics adventure game with arcade sound for your Color Computer! If you are bored with silent screens of text but enjoy the challenge and complexity of adventure games then SCEPTER OF KZIRGLA is for you.

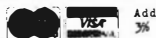

Add  
3%

16K Ext. Basic Req.  
\$16.95 cass - \$21.95 disk

Include \$2.00 shipping.  
Minn. residents add 5% tax.  
Dealer inquiries invited.



RAINBOW CONNECTION SOFTWARE  
3514 6th Place N.W.  
Rochester, MN 55901

Not affiliated with THE RAINBOW.



# GOLD LABEL™ BLANK CASSETTES

★PREMIUM 5 SCREW SHELL  
★COMPUTER DATA QUALITY ★LOW NOISE  
★MADE IN USA ★GUARANTEED

1 DOZEN C-10 LENGTH \$8.50 + \$2.50 shpg.  
2 DOZEN C-10 LENGTH \$16.00 + \$3.50 shpg.

1 DOZEN C-30 LENGTH \$12.50 + \$2.50 shpg.  
2 DOZEN C-30 LENGTH \$23.50 + \$3.50 shpg.

Individual storage boxes (sold only with cassettes) \$2.40 per dozen.  
CASSETTE CADDY: \$3.95 + \$2.00 shpg.  
2 for \$7.00 + \$3.00 shpg.

Free shipping on one caddy with each dozen cassettes.

Foreign orders include shipping at 16 oz. per dozen tapes/9 oz. per caddy/13 oz. per dozen boxes. Shipped in U.S. by UPS.

## CASSETTE CADDY

TIRED OF MISPLACED TAPES AND A CLUTTERED WORK AREA? TRY OUR HINGED TOP SMOKED PLASTIC CADDY THAT HOLDS 12 TAPES IN ONE HANDY LOCATION. EDGE LABELS INCLUDED TO IDENTIFY TAPES.

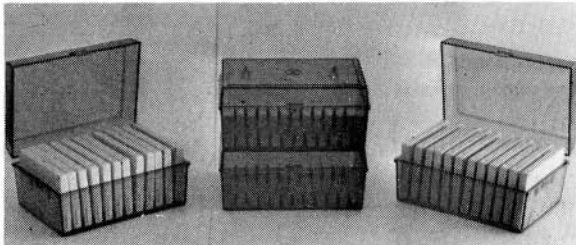

Visa and Mastercard accepted (include expiration date) Orders paid by cashier's check, money order or bankcard are shipped within 48 hours. Personal check takes 1-2 wks. No COD. Some foreign sales are restricted. Texas residents add 5% tax.

**COLOR SOFTWARE SERVICES**  
P.O. BOX 1708, DEPT. R  
GREENVILLE, TEXAS 75401

Telephone Orders: (214) 454-3674 9-4 Monday-Saturday

★DEALER INQUIRIES INVITED ★QUANTITY DISCOUNTS AVAILABLE

```

1290 NEXT
1295 GOSUB1000
1297 '*****
1298 ' ** score **
1299 '*****
1300 IFX<6THEN1350
1310 IFX>5ANDX<11THEN1375
1315 IFX>10ANDX<16THEN1380
1317 IFX>15ANDX<21THEN1390
1320 IFX>20ANDX<26THEN1410
1330 IFX>25ANDX<31THEN1420
1340 IFX>30ANDX<41THEN1430
1345 IFX>40THEN1435
1350 PRINT@416," "N$", YOU DID P
OORLY!"
1360 PRINT@448," YOU ONLY MADE I
T TO "X-1
1370 GOTO1440
1375 PRINT@416," "N$", YOU CAN D
O BETTER. ":GOTO1400
1380 PRINT@416," "N$", THAT WAS O
.K. ":GOTO1400
1390 PRINT@416," "N$", THAT WAS G
OOD!"
1400 PRINT@448," YOU MADE IT TO"
X-1:GOTO1440
1410 PRINT@416," "N$", THAT WAS
EXCELLENT!":GOTO1400
1420 PRINT@416," "N$", YOU ARE G
REAT!":GOTO1400
1430 PRINT@416," "N$", YOU ARE F
ANTASTIC!":GOTO1400
1435 PRINT@416," "N$", **UNBELIE
VABLE!!**":GOTO1400
1440 PRINT@485," PRESS P TO PLAY
AGAIN ";
1450 K$=INKEY$:IFK$=""THEN1450
1460 IFK$="P"THEN200ELSE1450
1497 '*****
1498 ' ** intermed routines **
1499 '*****
1500 MX=M(X)-M(X-1)
1510 IFMX>4THENM(X)=M(X)-5
1520 IFMX<-4THENM(X)=M(X)+5
1530 RETURN
1550 MX=RND(3)
1560 IFMX=3THEN1580
1570 IFM(X)>8THENM(X)=M(X)-5
1580 RETURN
1597 '*****
1598 ' ** maximum # **
1599 '*****
1600 PRINT@416," "N$", *I GIVE U
P!!*"
1610 FORZ=1TO250STEP5:SOUNDZ,1:N
EXTZ
1620 FORZ=1TO10:SOUND240,1:SOUND
250,1:NEXTZ
1630 GOTO1400

```

# LEARN A SECOND LANGUAGE ON YOUR COLOR COMPUTER • NEW • EXCITING • EASY

*Creative Courseware using the latest technology and Professional Programming*

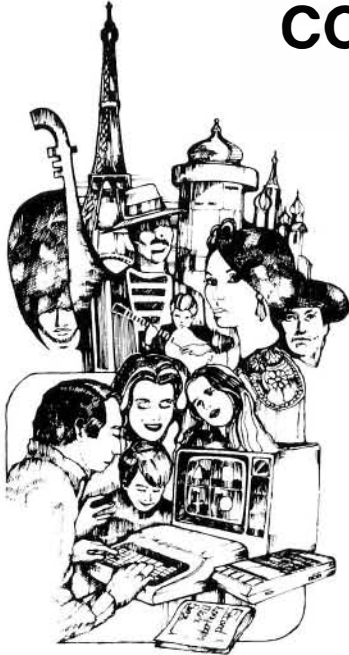

- Fulfill your educational objectives
- Have fun learning a new language
- Expand your children's horizons.
- Improve your job potential
- Young and old can learn
- Affordable, only pennies per hour.

- **SEE** — High quality visuals, not dotted graphics
- **HEAR** — High quality audio as spoken by natives
- **UNDERSTAND** — Through programmed instruction
- **RESPOND** — Branching, and looping insure learning.

**Our Lessons Teach You to HEAR and THINK in a Second Language**  
 These lessons are for you if you:

- Think you can't learn
- Have had previous difficulties
- Want to start out right
- Want language success

**Lessons Now Available in Spanish, English and French**

- Color Computer with 16K RAM and tape recorder required
- SLU-1: People, Persons & Family
- SLU-2: Stand, Walk & Run
- SLU-3: Smile, Eat & Talk
- SLU-4: House
- SLU-5: Open & Closed
- SLU-6: Furniture & Appliances
- SLU-7: Meals
- Vocabulary #1, 2 & 3: 200 words each

**Other Lessons and Languages Available Soon**

**Special Values**

**Special Value #1**  
 SLU 1-3, VOCAB 1, and Lesson Control A **\$129.75** Value for only **\$99.95**.  
 SV-1 (specify language desired) ... \$99.95

**Special Value #2**  
 SLU 1-7, VOCAB 1-3, and Lesson Control A **\$249.45** Value for only **\$199.95**.  
 SV-2 (specify language desired) ... \$199.95

**Demonstration Lesson** (for the doubter)  
 DEMO-1 ..... \$9.95

**Individual Lessons:**  
 (specify language desired)  
 Second Language Usage (SLU) \$19.95  
 Vocabulary (SL) ..... \$19.95

**Lesson Control:** (only one copy needed for all lessons and languages)  
 LC-CC ..... \$49.50

## HOW TO HEAR AND THINK IN A SECOND LANGUAGE

Skilled linguists have developed our series of second language programs. The lessons utilize the power of programmed instruction wherein you are advanced to new material only after satisfactory learning has occurred at the current level. Our techniques teach you how to think in a language without initially using any printed text material. No mental translation to your native language is required. You learn as a child does, hearing and speaking before reading. The computer both tutors and keeps track of progress as it moves you forward (or backward when review is necessary). AUDIO plus VISUALS plus INTERACTIVE RESPONSE establish the learning process, and literally THOUSANDS of visuals help seal-in the sound patterns of your new language.

All of our lessons are interactive and user friendly; yet, you are unaware of the complex course structure involved. For example: Lesson SLU-1 uses the theme of PEOPLE, PERSONS & FAMILY to teach the use of nouns to name things, to classify them into categories, and to identify members of a group. Sentence structure is developed using the verb 'be' and its relationship to nouns and adverbs, including plural forms and inversions. Noun structure using definite and indefinite articles, and regular and irregular plural forms is also presented. The other lessons are similarly designed. In addition, each VOCABULARY LESSON presents approximately 200 visuals and 200 words that are integrated into the learning process.

While the foregoing might seem complex, and it is, IT IS ALSO THE REASON OUR COURSEWARE CAN TEACH LANGUAGES. If you have tried 'game' or 'tape' language programs you know that they are ineffective. Our programs can teach you a language because we have successfully combined expert authoring of programmed courseware with **audio & visuals & response & branching** into a powerful tutorial package.

**DEALER INQUIRIES ACCEPTED**  
 We have a broad range of Audio Visual Computer Aided Instruction under development. Some users of our courseware might include Day Care Centers, Schools (public and private), institutions in various categories, individuals and language tutors.

**ABSOLUTELY NO RISK**  
 You may examine your order for 15 days. If you decide not to take advantage of the lesson(s) simply return in good condition for a full refund or cancellation of credit card charges.

**\*WE PAY UPS IN USA**  
 (street address required for UPS)  
 \*Add \$2.00 if US Mail desired.

\*Add 15% for foreign, APO & FPO (Remit in US Funds)  
 \*Virginia Orders add 4% sales tax  
 \*Mail credit card orders please include all card information

**WE ACCEPT**

- VISA and MASTER CARD
- Money Orders
- Certified Checks

● Other Checks (must clear before shipment)

**FREE ORDER LINE**  
 1-800-368-6300  
 \* \* \*

**FOR VIRGINIA ORDERS AND OTHER CALLS:**  
 1-804-463-6300  
 \* \* \*

**BASIC PROGRAMS, INC.**  
 236 Mustang Trail, #102  
 Virginia Beach, VA 23452

## Education and The Color Computer

By Dr. Paul Kimmelman  
Rainbow Education Editor

To begin, thanks to all of you who have sent the names of your school district's computer coordinators. While the numbers have not been overwhelming, we have begun to establish an educational Color Computer network. It is interesting to see how many people are working with the Color Computer for educational purposes and more significantly, writing their own educational programs. In the future, we will describe some of the programs being used.

We are also becoming more enlightened through the number of telephone calls and letters we receive requesting more information about the Color Computer and its use in the schools. At this point, we are informing everyone who asks that our use of the Color Computers has indicated that they are durable and from a service perspective they have been very reliable. We are also finding that many companies are beginning to develop third-party software and peripheral equipment to use with them.

In the very near future a compact 3" micro-floppydisk drive system will be distributed for the Color Computer. Some of the features of this system will include a shirt-pocket sized disk instead of the traditional 5 1/4" disk that can store up to 1 Megabyte of information. The plastic cartridge

has a flip-type head cover to protect it from dust, scratches and fingerprints. The system is a double-disk drive, and we should have more information on it by the next issue.

In addition, we are attempting to find monitors to use with the Color Computer. The significant advantage will be improved resolution for programs that require this type of clarity. There is a possibility that one of the problems of using the Color Computer with a monitor has been eliminated through the development of a cable that will enable Color Computer owners to use a true video monitor.

Now for the important part of using the Color Computer in our schools. If anything is becoming apparent, it is the fact that regardless of whether the Color Computer is being used in the home or in the school, the basis for its use should be designed to help young people learn more about how to control the computer. It is important that everyone realizes the basic categories that the computer can be used for with students.

First, many programs are designed to have the student respond to problems or questions displayed on the monitor. We believe that this type of instruction is important as long as it is used in conjunction with regular classroom instruction or as a supplemental activity.

More importantly, however, now is the time to begin establishing a basic curriculum for computer use and that curriculum must include working with programs such as *LOGO*. The young child who cannot read can very easily work with a parent or teacher and use the *LOGO* doodle mode to discover how he or she can make the turtle move around the screen. From there, as the child learns to read, there can be a gradual evolution of a more sophisticated curriculum whereby the child could be required to write his or her own programs. Children adapt to *LOGO* with ease.

We have heard from some individuals who are critical of *Color LOGO* because of several features that it does not include. It seems to me that we should focus on those aspects of the program that exist. The features that are not included will not affect young children's usage of *Color LOGO* to any significant extent.

*LOGO* is rapidly emerging as a popular children's language. The ROM pack that Radio Shack will produce will be more than adequate for young children who want to become familiar with this language. By the time they have mastered the components of *Color LOGO*, they will be ready to handle programming with other structured procedural languages.

We believe that we should encourage the use of the computers beginning with a child's kindergarten experience. Kindergartners are capable of using joysticks with programs such as *Popcorn* and learn concepts such as directions—up, down, right and left. From that point the use of the doodle mode in *LOGO* and many other letter recognition programs will enable them to become comfortable and competent with the computer. Perhaps the most important aspect of computer education is that we develop fundamental skills and build upon them in a sequential manner.

The last component of the computer program—games—is one that is being debated by many educators and parents. I believe that games play a significant part in motivating students to work with computers. Like anything else, too much of any one activity could be counterproductive. However, student use of computers with programming languages, drill and test routines, and games can all be used interchangeably to develop a fundamentally sound computer literacy curricular program.

(Dr. Kimmelman is assistant superintendent of Norton City Schools, Norton City, Ohio.)

### COLOR COMPUTER SOFTWARE

#### Adventure games

- **THE ALCHEMIST'S LABORATORY - \$14.95**

mix the ingredients that will  
turn lead into gold.

- **LOKAR'S MAGIC STAFF - \$14.95**

can you unlock the deadly secrets of **LOKAR'S** magic staff?

- **MEGAMAZE - \$14.95**

a wild, five dimensional space maze adventure.

- **SQUEEZE - \$14.95**

arcade style game where aliens close in from both sides at once.

- **GRAPHIC SCREEN EDITOR - \$16.95**

create pictures on the screen using joysticks or arrow keys—save on tape, erase, paint, and many other features.

- **COLOR SHOW DISPLAYS - \$8.95**

five graphics programs that create endless changing patterns.

all programs 16-K extended basic cassette only.

Send for free catalogue. We accept checks, money orders, Visa and Mastercharge. (no C.O.D.'s) Please add \$1.00 for shipping. Send to:

**REAL SOFTWARE CO.**

**P.O. BOX 401 ● HOPEDALE, MA 01747**

**(617) 393-6281**

CIS orders EMAIL to 71505,430

Mass. residents add 5% sales tax

Dealer inquiries welcomed







## Let's Try Fantasy Role Playing Games

By  
George Fire Drake  
and  
Bob Albrecht

Millions of young people, and many not-so-young, are playing fantasy role playing games. A role playing game is a game in which one or more players create and control characters (adventurers) who live their imaginary lives in a specially made game world. The game world is created, managed, and operated by a GameMaster (GM), also called a referee, adventure master, or dungeon master (DM).

Most people who play role playing games use a formal rule system. Some of the best known are shown below.

**Dungeons & Dragons (D&D).** From TSR Hobbies, P.O. Box 756, Lake Geneva, WI 53147.

**RuneQuest (RQ).** From Chaosium, P.O. Box 6302, Albany, CA 94706.

**Tunnels & Trolls (T&T).** From Blade, Box 1467, Scottsdale, AZ 85252.

**Worlds of Wonder (WOW).** From Chaosium, P. O. Box 6302, Albany, CA 94706.

**BEGINNERS BEWARE!** The rulebooks are very difficult to understand. If you are a beginner, first try *Worlds of Wonder* or *Tunnels & Trolls*.

### GameMaster's Dice

Most role playing game systems use dice to determine the outcomes of events. Dice are rolled to find out whether something happened or didn't happen. Did a character find the hidden treasure, or open the secret door, or hear the monster sneaking up behind her? Did the character solve the puzzle that unlocks the magic chest or read the cryptic runes? Who won the melee between the good guys and the bad guys? How much damage did our character take when he fell out of the tree? Roll dice to find out.

Dice are used to determine success or failure in using weapons. If a weapon attack is successful, dice are used to determine how much damage is inflicted. If a character can use magic, dice are rolled to determine if a spell is cast successfully and what its effects are. In playing a game, you spend much time rolling dice and interpreting the results of a roll. Fantasy role playing, like life itself, is part skill and part luck.

GameMaster's Dice come in many shapes, from tetrahedrons (4 sides) to icosahedrons (20 sides). We assume you are already acquainted with ordinary six-sided dice. We use the abbreviation D6 to mean one six-sided die.



D6

D6 is one six-sided die  
1D6 is one six-sided die  
2D6 are two six-sided dice  
3D6 are three six-sided dice  
and so on.

Of course



We also use less familiar dice, such as:



D4

D4 is a tetrahedron, with sides numbered 1 to 4. The number rolled is the one that is right side up after you throw the die.



D8

D8 is an octahedron, with eight sides numbered 1 to 8.



D12

D12 is a dodecahedron, with twelve sides numbered 1 to 12.



D20

D 20 is an icosahedron, with twenty sides numbered 1 to 20.



DIGIT DICE

A **digit die (DD)** can be a ten-sided die, with sides numbered 0 to 9, or an icosahedron with twenty sides numbered 0 to 9 (each number appears twice).

We use digit die (DD) to roll a **decimal digit**, 0 to 9. However, sometimes we want to roll D10, a number from 1 to 10. Easy—roll a DD and use 0 to mean 10.

**REMEMBER:** A **digit die (DD)** is a 10 or 20-sided die whose faces are numbered 0 to 9.

D100 is a **percentage** roll, also called a **percentile** roll, with numbers from 00 to 99. To make a percentage roll, use a DD (digit die), roll it twice. The first roll is the **ten's** digit; the second roll is the **one's** digit. If you roll a 3 the first time and a 7 the second time, the number is 37.

Or use two digit dice of different colors. One color (silver? gold? yellow?) is the ten's digit and the other (white? copper?) is the one's digit.

Sometimes, zero zero (00) is a **fumble**. If you roll a fumble ... alas ... your character may trip on his sword, drop the chest of gold on his foot, fall out of the tree in which he is hiding, or suffer another calamity gleefully prescribed by the GameMaster. (GameMasters love it, when *you* fumble.)

If you browse the literature of role playing games, you may encounter other dice abbreviations.

**D3**

Roll a D6 and read the results as follows:

- 1 or 2 is 1
- 3 or 4 is 2
- 5 or 6 is 3

The possible values for D3 are 1, 2, or 3.



**D6+1**

Roll a D6 and add one to the result. Possible values are 2 to 7 (2, 3, 4, 5, 6, or 7).

**3D4**

Roll three four-sided dice and add them. Possible values are 3 to 12. These values are not equally probable.

**D6+D4**

Roll one D6 and one D4, then add the results. Possible values are 2 to 10.

Another way to roll D3 is to roll D4. If you get 4, ignore it and roll again. If you don't have the proper dice, improvise!

Or, use your CoCo to roll dice. First, we challenge you to write a program to roll N dice, each with S sides. Yes, if you want, you can roll two-sided dice, or seven-sided dice, or 13-sided dice, or whatever imaginary dice *you* create. Hmm ... if you do, think about what they might look like. Send us your designs for *fair* dice with 2, 7, 13, (and so on) sides.

Yup, we wrote a program to roll dice. Here is a RUN of our program.

DICE? 3D6  
12

DICE? 2D7  
6

DICE? DD  
4

DICE? P?  
73

DICE? D20 (Same as 1D20)  
16

DICE? and so on

We used DD to mean "Digit Die." We used P to mean "Percentile" roll.



Next time, we will show you our first GameMaster's Dice program. In the meantime, keep on rolling.

**True Names, And Other Names**

In role playing games, names are important. If you read fantasy, perhaps you know some of these names.

FRODO    GANDALF    ARAGORN    GIMLI  
ELROND    CONAN    ELRIC    GED

If you acquire a character to play in a game, you usually get to choose the name of your character. You may choose any name, including your own name or the name of a friend. Any name is OK.

You might want to give your character a name different from the names you are used to, a name that "sounds like" the kind of person (human or otherwise) your character is. In a future article, we will talk about names that sound Gaelic, or Dwarvish, or Elfen, or whatever. This time, we will talk about *random* names that have a certain flavor.

When you see or hear:

ROKAR    BARAK    KUMAN    MORAB

What do you think about them? What kind of characters might they be? How about:

MOSAS    SOMAL    RAMOS    MIKOS

Without any additional information, pick three of the above as people to go adventuring with.

All of the above names have the form:

CONSONANT  
VOWEL  
CONSONANT  
VOWEL  
CONSONANT

We challenge you to write a program to create and display five-letter names consisting of: CONSONANT, VOWEL, CONSONANT, VOWEL, CONSONANT. We suggest your program should display several names, then say "FOR MORE NAMES, PRESS SPACE." If someone presses the space bar, you see one more line of names.

Think ahead. Anticipate what we might ask next. For example:

NAME STRUCTURE? CVCVC  
HOW MANY NAMES? 20

CoCo prints  
20 names

Consonant, Vowel  
Consonant, Vowel  
Consonant.

TO DO AGAIN, PRESS SPACE

So, we press the space bar and,

NAME STRUCTURE? VCCVC  
HOW MANY NAMES? 16

CoCo prints  
16 names



TO DO AGAIN, PRESS SPACE

With this program, you can try lots of name "flavors!"

### Scan The Character File

Last time, we showed you a program to look up and display the seven basic characteristics for a *RuneQuest* or *Worlds of Wonder* character. Information on each character is stored, by name of character, as a *record* in a *file* of records in DATA statements. You ask for a character by name and the CoCo displays the information for that character.

This time, a program to scan the entire file, beginning with the first record. To get the next record, you press any key. If the CoCo is already displaying the last record, you press any key. If the CoCo is already displaying the last record in the file (ENDFILE), pressing a key causes it to start over with the first record.

When you *RUN* the program, first you see:

```
NAME: ALOYSIOUS
```

```
STR          10
CON          11
SIZ          10
INT          12
POW          10
DEX          12
CHA          9
```

```
FOR NEXT RECORD, PRESS ANY KEY
```

So, press a key and see the second record in the file.

```
NAME: BAROSTAN
```

```
STR          17
CON          17
SIZ          13
INT          8
POW          7
DEX          15
CHA          6
```

```
FOR NEXT RECORD, PRESS ANY KEY
```

Keep pressing and eventually you will see the End-Of-File record. It looks like this:

```
NAME: ENDFILE
```

```
STR          0
CON          0
SIZ          0
INT          0
POW          0
DEX          0
CHA          0
```

```
FOR NEXT RECORD, PRESS ANY KEY
```

If you now press a key, the CoCo will start over with the first record (ALOYSIOUS).

Here is the program:

```
100 REM**SCAN CHARACTER FILE
300 REM**BEGINNING OF FILE
310 RESTORE
```

```
400 REM**READ A RECORD
410 READ NAME$
420 READ STR, CON, SIZ, INQ, POW,
DEX, CHA
```

```
500 REM**PRINT CHARACTER'S NAME
510 CLS
520 PRINT NAME$
```

```
600 REM**PRINT CHARACTERISTICS
610 PRINT
620 PRINT "STR", STR
630 PRINT "CON", CON
640 PRINT "SIZ", SIZ
650 PRINT "INT", INQ
660 PRINT "POW", POW
670 PRINT "DEX", DEX
680 PRINT "CHA", CHA
```

We use INQ because  
INT is a reserved word



```
700 REM**TELL HOW TO DO AGAIN
710 PRINT
720 PRINT "FOR NEXT RECORD, PRES
S ANY KEY"
730 IF INKEY$ = "" THEN 730 ELSE
810
```

```
800 REM**START OVER IF ENDFILE
810 IF NAME$="ENDFILE" THEN 310
ELSE 410
```

```
1000 REM**DATA FILE
1010 DATA ALOYSIOUS, 10, 11, 10,
12, 10, 12, 9
1020 DATA BAROSTAN, 17, 17, 13,
8, 7, 15, 6
1030 DATA BRIDLA, 11, 12, 10,
15, 6, 11, 6
1040 DATA DERNFARA, 13, 13, 8,
13, 4, 17, 6
1050 DATA JOLEEN, 13, 11, 7,
13, 8, 17, 13
1060 DATA ROKANA, 9, 9, 9, 17,
18, 9, 10
1070 DATA ENDFILE,0,0,0,0,0,0,0
```

You can change the records in the DATA FILE to records for *your* characters, or add your character records to the DATA FILE. Remember to put ENDFILE in the *last* DATA statement.

Next time, we will combine two programs, CHARACTER FINDER and SCAN CHARACTER FILE, into a single program with a *menu* that lets you select which you want to do.

```
RND(RND(N))
```

Last time, Hieronymus Heuristicus wrote a program to compute a bunch of *RND(RND(2))* numbers and count how many ones and how many twos occurred. One of his

# YOUR COLOR COMPUTER JUST GOT WHEELS!

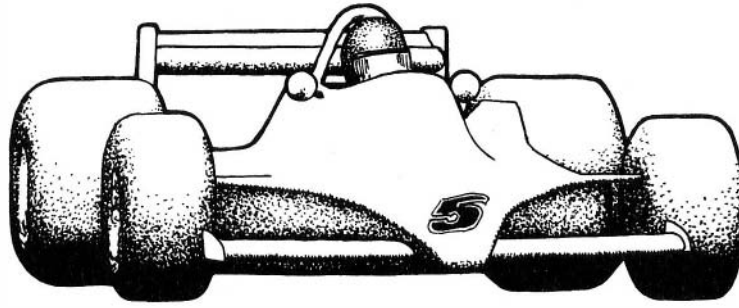

## REVOLUTION!

You accelerate hard down a long straightaway, braking heavily at the end for a hard corner. You slice smoothly through the esses, and then boldly keep the power on for a fast sweeper. The Ferrari drifts dangerously near the edge, but you make a tiny correction in the steering, and you are through.

The finish line flashes by, and suddenly you are in the pits. The car falls silent. You see your lap times being held up. Your final lap was a new lap record! At last, you permit yourself a small smile.

You have mastered this powerful car on a difficult track, driving with the assurance and precision that comes only from long hours of practice.

You are driving an *authentic* race car. You are playing *Revolution!*

### FANTASTIC ACTION

*Revolution* uses high resolution, machine language graphics for action that is smooth and fast. The emphasis is on authenticity in the control and motion of your car. As in driving a real race car, accuracy and precision in your driving are what counts. Frills and non-essentials have been left out.

### PURE COMPETITION

Like a real race driver in practice and qualifying sessions, you compete against the clock and against the existing lap record for that track. *Revolution* records the lap records and the name of the person who set the record, so you always know who reigns supreme on your favorite track!

### DESIGNED WITH YOU IN MIND

*Revolution* is menu-driven, and self explanatory. Information screens tell you what you need to know. When you're ready to play, a menu of the names of all your tracks is displayed, along with the lap record for each track and the name of the person who set that lap record. You select a track with a single keystroke, and *Revolution* takes you there.

### A NEW CONCEPT

*Revolution* is a unique game, because it allows you to create the most important part of any race game: the track itself.

The first time you run *Revolution*, you will be able to choose from several tracks and cars which are included with the game.

But, with *Revolution*, this is only the beginning! You can create as many tracks as you like. You can make each new track as difficult or as easy as you wish. You can make easy ones to begin with, and tougher ones as you become more skilled. You may find creating tracks to be almost as much fun as driving on them!

You can save your favorite tracks to run on again whenever you wish. *Revolution* will automatically add these new tracks to the menu. And you can exchange your favorite tracks with other *Revolution* owners.

Be careful, though, about letting your friends play this game. They may not want to let you have your computer back!

### THE EARLY REVOLUTION

A prototype version of *Revolution* was published in the September, 1982 issue of *Rainbow* magazine, under the name *The Track*. The response to *The Track* has been terrific.

*Revolution* has all the features that have made *The Track* a favorite, and *Revolution's* fast, high-resolution machine language graphics are dramatically improved over the prototype's.

### REVOLUTION NOW!

The original *Revolution* for the TRS-80™ Color Computer requires 32K and one disk drive. A new cassette version has action just like the disk version, and similar track-saving features excluding a menu of available tracks. The cassette version will run on a 32K Color Computer or TDP-100. You can upgrade to the disk version later, too, for a nominal fee.

#### REVOLUTION

For 32K Disk . . . . . \$24.95

Requires Joysticks  
& Extended BASIC

For 32K Cassette . . . \$21.95

Connecticut residents add 7½% sales tax.  
TRS-80 is a trademark of Tandy Corporation.



Inter  Action



113 Ward Street • Dept. R • New Haven, CT 06519 • (203) 562-5748



RUNs looked like this:

```
HOW MANY RANDOM NUMBERS? 1000
POSSIBLE VALUE  NUMBER OF TIMES
1                758
2                242
TO DO AGAIN, PRESS ANY KEY
```

H.H. asked for a *sample* of 1000 *RND(RND(2))* numbers. He expected to get about the same number of ones and twos. Instead, he got about three times as many ones as twos.

Undaunted (and curious), he wrote a new program to gather information about *RND(RND(3))*, *RND(RND(4))*, and so on. Here is his program:

```
100 REM**RND(RND(N)) NUMBERS
200 REM** DIALOG WITH A PERSON
210 CLS
220 INPUT "FOR RND(RND(N)), WHAT
IS N"; N
230 INPUT "HOW MANY NUMBERS"; S
300 REM**START COUNTS AT ZERO
310 FOR K=1 TO N
320 : C(K) = 0
330 NEXT K
400 REM**COUNT RANDOM NUMBERS
410 FOR K=1 TO S
420 : X = RND(RND(N))
430 : C(X) = C(X) + 1
440 NEXT K
500 REM**PRINT RESULTS
510 PRINT
520 PRINT "POSSIBLE VALUE", "NUM
BER OF TIMES"
530 FOR X=1 TO N
540 : PRINT X, C(X)
550 NEXT X
600 REM**TELL HOW TO DO AGAIN
610 PRINT
620 PRINT "TO DO AGAIN, PRESS AN
Y KEY";
630 IF INKEY$ = "" THEN 630
ELSE 210
```

Curious, H.H. typed *RUN*.

```
FOR RND(RND(N)), WHAT IS N? 2
HOW MANY NUMBERS? 1000
```

He hasn't pressed *ENTER* yet.

To check out his program, H.H. first asks for a bunch of *RND(RND(2))* numbers. So he enters 2 as the value of N. In response to the computer's query about how many numbers, he asks for 1000 numbers.

Now, H.H. presses the *ENTER* key. He waits patiently for the computer to do the work, and soon sees:

```
FOR RND(RND(N)), WHAT IS N? 2
HOW MANY NUMBERS? 1000
POSSIBLE VALUE  NUMBER OF TIMES
1                743
2                257
TO DO AGAIN, PRESS ANY KEY
```

Seems okay, so H.H. presses the space bar and asks for another sample, this time for N=3.

```
FOR RND(RND(N)), WHAT IS N? 3
HOW MANY NUMBERS? 1000
POSSIBLE VALUE  NUMBER OF TIMES
1                607
2                284
3                109
TO DO AGAIN, PRESS ANY KEY
```

H.H. then tried values of 4 and 5 for N. "Hmmm," thinks H.H., "I'm beginning to see a pattern here." So he tried 6 and 7.

"Aha! Eureka! I think I've got it!" exclaimed Hieronymus. "But why?" So, again, he called on his friend Annalee Analyticus to explain the *why* of the *what* his experimental investigations suggested to him.

Based on H.H.'s evidence, and more evidence that *you* obtain by running H.H.'s program, answer these questions:

- For *RND(RND(2))*, what is the probability of getting 1? , 2? .
- For *RND(RND(3))*, what is the probability of getting 1? , 2? , 3? .
- For *RND(RND(4))*, what is the probability of getting 1? , 2? , 3? , 4? .
- And so on. Mathophiles please generalize to *RND(RND(N))* where N is a positive integer. You will love the pattern.

### Coming Attractions

Surely, but slowly, we will explore the following things:

- The Elusive RND
- GameMaster's Dice
- Looking up stuff in files. First, files of information in DATA statements and arrays. Next, cassette files. Eventually, disk files.
- Whatever else comes to mind or is suggested by you.

What do *you* want? If it fits into the general idea of "GameMaster's Apprentice," we might do it. Send your suggestions, complaints, kudos, requests, whatever ... to George & Bob, P.O. Box 310, Menlo Park, CA 94205.

# TRS-80C® and TDP 100® SPECIALISTS



## COLORFORTH®

IS THERE LIFE AFTER BASIC? Yes! with COLORFORTH, a new, high level language for the color computer. COLORFORTH, a figFORTH compiler, has an execution time as much as 10 to 20 times faster than Basic, and can be programmed faster than Basic. COLORFORTH is highly modular for easy testing and debugging. COLORFORTH has been specially customized for the color computer and requires only 16K. It **does not** require Extended Basic. When you purchase COLORFORTH, you receive both cassette and RS/DISK versions, the figEDITOR and an extensive instruction manual. Both versions and 75 page manual, all for only . . . . . \$ 49.95

## PCFORTH

FORTH for the IBM PC® and Zenith Z-100®. All the features of COLORFORTH, but customized for the IBM and Zenith Z-100 personal computers. Requires 32K and MS/DOS or IBM/PCDOS. On 5-1/4" SSDD diskette. Complete with 75 page manual, just . . . . . \$ 59.95

**NEW!**

## MASTER MIXOLOGIST® The Bartenders' Guide

This disk based program for the color computer contains recipes for over 150 of your favorite bar drinks—both alcoholic and non-alcoholic. MASTER MIXOLOGIST is menu driven for ease of use. Requires 16K and one RS/DOS drive. Get this one today, it will be great for your next party . . . . . \$ 19.95

## ARMADILLO BUG® MACHINE LANGUAGE MONITOR

More and more programs are appearing in magazines written in Machine Language. Now with ARMADILLO BUG, you can easily enter Machine Language programs without a lot of time consuming "pokes". ARMADILLO BUG is an excellent system for beginners to learn to write and debug their own Machine Language programs as well. This package includes: Memory examine and change; Move; Punch and Load; Fill commands; and more! Runs in 16K, and **DOES NOT** require Extended Basic. Complete on cassette with printed manual. Just . . . . . \$ 14.95

## COLOR BIORHYTHMS

This is a neat BIORHYTHMS program you can use to chart the future (or past). Includes High Resolution graphics **without** Extended Basic being required. Runs in 16K. On cassette, with instructions . . . . \$ 10.95

## OTHER ITEMS OF INTEREST

"STARTING FORTH", a book by Leo Brodie. The best introductory Forth text available. 384 pages. Soft cover . . . . . \$ 16.00

figFORTH Installation Manual. Contains FORTH model, glossary, memory map, and instructions . . . . . \$ 15.00

figFORTH 6809 Source Listing. (NOTE: THIS IS NOT IDENTICAL TO COLORFORTH SOURCE). Requires installation manual for implementation . . . . . \$ 15.00

**BUY BOTH** at the same time and **SAVE!!** Both for . . . . . \$ 25.00

"Computers Piss Me Off". Wear the official programmers badge. Large 2-1/4" yellow button says it all! Post paid . . . . . \$ 1.50

"I ♥ My Color Computer". White button with black lettering and red heart. 2-1/4". Post paid, only . . . . . \$ 1.50

### DEALER and AUTHOR INQUIRES INVITED

Please add \$ 2.00 shipping in U.S.

Texas residents add 5 %

Foreign orders must be in U.S. funds drawn on U.S. banks, or Mastercard and VISA

## ARMADILLO INT'L SOFTWARE

P.O. BOX 7661  
AUSTIN, TEXAS 78712



PHONE (512)835-1088

## Whether Androids or Robots This One's A Fun Challenge

*Android Attack* (formerly *Robot Battle*) is a machine language, high resolution, arcade-type game from Spectral Associates. It pits you against a varying number of relentless, but at times not-too-bright killer androids, and . . . if you're fortunate enough to have 32K, the game will talk to you. I'm sure you're familiar with the genre. The player, in a protective suit, wanders from one set of rooms to another trying to destroy androids and gather treasure before the androids can destroy him. While doing this the player must avoid the electrified walls.

The game comes in two versions on a cassette, a 16K version and a 32K talking version. The 'talking' feature is a nice touch. The verbalizations are, as you would expect, mechanical in nature, but understandable. The mechanical aspect of the phrasing fits in nicely with the game's concept of man against machine. Both versions loaded easily into my 32K CoCo. The instructions state that the game will run on the CoCo, TDP, and Dragon Data. It requires 16K and joysticks. Extended Basic is not required.

The instructions set up an appropriate scenario and are clearly written. The game has 16 levels (0-15), and as the skill level increases, the androids pursuit, firing speed and accuracy increase accordingly. The names and scores of the top ten players for each load are displayed between each game. Spectral was also nice enough to include instructions for saving the game to disk.

As to the details of the game itself, you begin each game with four units of protection. You gain an additional unit of protection for each 10,000 points earned, up to a maximum of ten units. Each room is made up of a random series of walls with randomly placed exits, and a varying number of robots, all intent on shooting you.

Three sets of information are presented at the bottom of the screen: your accumulated score, a somewhat hard to understand bar of changing colors that show your remaining units of suit protection, and a timer that counts down to

zero. The counter is reset for each room and if you have not exited the room before it reaches zero, you are automatically destroyed. Each time you exit a room it scrolls off the screen and a new and different one takes its place.

Player control is via the right joystick and is clearly explained in the instructions. You can direct fire and movement in eight different directions, and you also have the ability to jump and duck to avoid the androids fire. I found this added to the challenge of the game once you had mastered the steps involved. Each android you destroy turns into a mine that must be avoided. These mines, after a period of time, turn into ghost androids with the capabilities of pursuing you through the walls.

You get 50 points for each android you destroy, 100 points for each ghost android destroyed and 100 points for picking up the crown in each room. There is also a bonus feature. Once you clear a room of all androids and the crown, and have exited the room, you get a bonus of the time left on the countdown timer added to your score. After earning bonus points, the difficulty level of the ensuing rooms will increase and the androids will become smarter and faster. Your protective suit loses a unit of protection each time you come into contact with a wall, mine or android. You also lose a unit if you are hit by android fire.

I found the game quite enjoyable and challenging. Twelve-year-old Mike and seven-year-old Jamie, two veteran gamers, really got into this one. The graphics and animation are clear and smooth. The talking feature, while a little hard to understand at times, is adequate and adds to the enjoyment of the game. My only criticism is of the bar that shows how many units of protection you have left. While you can figure it out, it's hard to just glance at during the course of playing and get much information of a specific nature. Every other aspect of the game is top notch, and if you enjoy a game that will challenge your hand-eye coordination as well as require a little strategy to maximize your bonus scores then give *Android Attack* a try.

(Spectral Associates, 141 Harvard Ave., Tacoma, WA 98466, \$21.95 )

—Randall A. Smith

## ARE YOUR WALKING FINGERS GETTING FOOTSORE ?

Tired of typing in those long, but wonderful, programs from each issue of **the RAINBOW**? Now, you can get **RAINBOW ON TAPE** and give those tired fingers a rest. With **RAINBOW ON TAPE**, you'll be able to spend your time enjoying programs instead of just typing...typing...typing them! All you need to do ever again is pop a **RAINBOW ON TAPE** cassette into your recorder, CLOAD and RUN any one you want.

**RAINBOW ON TAPE** is available as a single issue for \$6.50 or on a yearly subscription basis for only \$60. It is the perfect complement for **the RAINBOW** itself.

VISA, MasterCard and American Express accepted. All subscriptions begin with the current issue and back issues are available beginning with April, 1982. Subscriptions are sent first class mail to coincide with the arrival of your current issue of **the RAINBOW**.

Now . . .

### The Best Color Computer Magazine Offers The Best Tape Service

Think of it! Not 10 or a dozen—but between 20 and 30—programs every month from **Rainbow On Tape**. All the really good programs from the **Rainbow**! All the long ones . . . so you don't have to type them in. Just CLOAD and RUN!

**ORDER RAINBOW ON TAPE TODAY!  
HANDY ORDER CARD BETWEEN PAGES 34 and 35**

# 80-U.S.

THE TRS-80 USERS JOURNAL

If you own a TRS-80® Model I, Model II, Model III, the Color Computer, or the new Pocket Computer, YOU NEED 80-U.S.!

## The 80-U.S. Journal has

programs for your enjoyment and enlightenment. Every issue contains several Basic or machine language program listings. It contains Business articles and program listings. No matter where you are, there is something for YOU in the Journal!

*and...*

The Journal contains reviews of hardware and software. Our "Evaluation Reports" will help you make the best choice in selecting additions to your system.

## Save Over 50%

You can save over 50% off the cover price of *80-U.S. Journal*. For the remarkably low price of *only* \$16.00, a savings of \$20.00 (cover price), you will receive a wealth of useful information every month. As a special **BONUS**, if you enclose payment with your order, you will receive an extra issue for each year of your subscription order. *Order three years of 80-U.S. and receive three extra issues! At no cost to you!*

Is your  
TRS-80  
Lonely?

Write today for  
our

"No Risk Offer"

SEND TO:

80-U.S. Journal  
3838 South Warner Street  
Tacoma, Washington 98409  
Phone (206) 475-2219

Name \_\_\_\_\_

Address \_\_\_\_\_

City \_\_\_\_\_ State \_\_\_\_\_ Zip \_\_\_\_\_

Visa/MC \_\_\_\_\_

Exp. Date \_\_\_\_\_

1 yr. \$16     2 yrs. \$31     3 yrs. \$45

Please allow 6 to 8 weeks for your first issue.

TRS-80 is a Registered Trademark of the Tandy Corp.



# Curvfitz Is Number Cruncher Of The First Order

By Mark Laessig

All of us Color Computer owners are hungry for new uses for our machines. The following article will show you how to do some useful and educational "number-crunching," for a little change from games and graphics. What I'll show you is called curve-fitting, which is a process where a computer can solve for a mathematical relationship that fits some measured data from an experiment with maximum possible accuracy.

Sound confusing? Let me give you a simple example dear to the hearts of us programmers. Let's say you've just written a new alphabetical sorting program for your Color Computer. How would you estimate how many names it would sort in a day's execution? Well, you could burn a whole lot of electricity, or you could do it much more easily. Instead you could time how long it takes to sort some name lists of convenient lengths, as in the make-believe data table below:

Names sorted	Time-seconds
20	2
50	6
100	13
150	22
200	31

Now from this data we should be able to make a prediction if we could use these numbers to make up some easily-calculated expression. The program I've given you at the end of this article, called *Curvfitz*, does just that. When you input your experimental data, like the five pairs of numbers above, *Curvfitz* will solve for the numbers  $c(0)$ ,  $c(1)$ , and so on for the relation:

$$Y=c(0)+c(1)*X+c(2)*X^2+c(3)*X^3+\dots$$

where "Y" can be the number of names sorted and the "X" is the program's execution time in seconds. What do the trailing periods at the end of the equation mean? Well, you can solve for as many numbers  $c(0)$ ,  $c(1)$ , and so on—called coefficients—as you like. For instance, if you only solve for the first two, you're trying to "fit" your data with a minimum of error to the relation

$$Y=c(0)+c(1)*X$$

which is the equation for a straight line. This is called a "first-order" curve fit. Had we decided to solve for three coefficients, this would be a second-order fit, and so on. Now, many things in nature are governed by "straight-line" relations, like the money you make compared to the hours you work, for instance. But many are more subtle than that, requiring the "higher-order" fits to match the data better. To see how good a match to your data a certain fit is, *Curvfitz* will both compare the fit to the data you input numerically, and will also plot a graph of both of them for you using PMODE4 graphics.

This will be clearer after we use *Curvfitz* to solve our sorting program example. Key in *Curvfitz*, type PCLEAR4,

and then RUN. You have to PCLEAR4 first due to the DIM statements on lines 200-230. You're first asked for the number of data point pairs, which in our case is five. You're then asked for the order fit you want. Let's try a straight line for now, so type one. Notice that you have to have more data points than the order fit you want, but this usually isn't a problem. You're next asked to input your data, with the X and Y prompts having the same meaning as in the relation I gave earlier. Since we'd like to eventually solve for names sorted, let's have execution time be X and names sorted be Y. If you make a mistake in inputting your data, you can

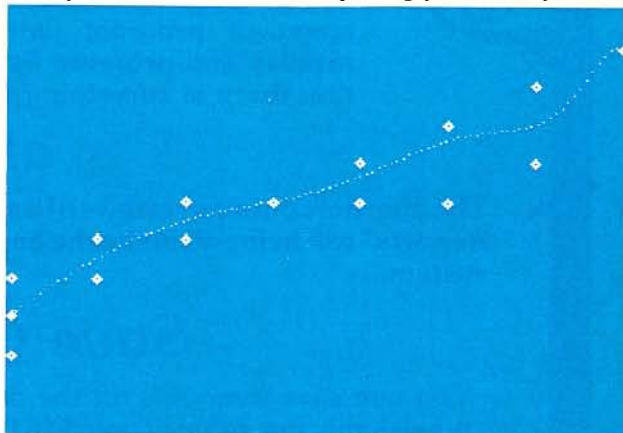

cycle through it again and simply change values. When you're ready, type "N" in response to the prompt for rechecking data and *Curvfitz* will "crunch" for a bit and print out your coefficients. If you did everything right, you should get  $c(0)=12.784$  and  $c(1)=6.163$ .

Once you've copied these numbers down someplace, hit enter and *Curvfitz* will show you how good a first-order straight line fit is by outputting a table of measured X and Y values along with the Y values the fit would predict at that point. For 13 seconds execution, the fit predicts 92.9 names sorted instead of 100, which might be accurate enough for you. At this point, *Curvfitz* will also plot on the screen the fitting curve and the measured data. The plot is automatically scaled to fit on the screen with the low X and Y values in the lower left-hand corner. In this way you can see graphically whether or not your fit is a good one.

So how many names would be sorted in a day? Since a day is 86,400 seconds, then

$$\text{Names sorted} = 12.784 + 6.163 * (86400) = 532,500 \text{ names,}$$

or the size of a medium phone book!

What about a second-order fit? Well, when you try it you'll find that it'll match the data better within the range of measurements you've taken, but outside that range things might be less accurate than before. Every time you increase the order of the fit, you're allowing more "wiggles" to appear in your fitting curve, which may have bad consequences. A second-order fit on our sorting problem, for instance, tries



# Genesis Software

presents

## Color Computer Programs

### ★ Secret Of The Crypt **New!!!**

The BIG adventure continues. The sequel to the popular "Enchanted Forest" is here! You'll move in more than 50 hi-res, 3-D graphic scenes searching for clues in an attempt to enter the crypt. But beware, the trail to the crypt is beset with puzzlements. In fact, the crypt's secret will remain a mystery to all but the most adventuresome. Requires 32K extended basic.

Tape cassette (postage paid).....\$21.95

### ★ Bigfoot

Hunt Bigfoot in a hidden maze of caverns and twisting tunnels that are displayed in hi-res graphics as you move. Seek out the lair of Bigfoot while avoiding perils along the way. Features multiple levels and many options of play. Each hunt takes place in a new, randomly generated maze. Challenging and fun. Requires 32K extended basic. Tape cassette (postage paid).....\$21.95

### ★ The Enchanted Forest

The BIG adventure in hi-res graphics. Move through more than 50 scenes on a quest to rescue the captive princess. Decisions are made according to visual clues, not text. There are many inhabitants in the Enchanted Forest — some are friendly, some are not. This is a sophisticated computer adventure — a real challenge. A must for your adventure library. Requires 32K extended basic.

Tape cassette (postage paid).....\$21.95

(The Enchanted Forest was reviewed in the Dec. 1982 issue of Rainbow).

### ★ The Game Show

Now a lively party game where two teams compete against the clock to name several items in a category. Includes 60 rounds with color graphics and sound. Machine language routine for fast response. Requires 16K extended basic and joysticks.

Tape cassette (postage paid).....\$19.95

(The Game Show was reviewed in the Jan. 1983 issue of Rainbow).

## Genesis Software

P.O. Box 936, Manchester, Mo. 63011

Personal checks welcome - no delay.  
Missouri residents add 5.625 percent sales tax.

```
330 IF I=1 AND Q$<>"N" THEN XL=X
X: XH=XX: YL=YY: YH=YY
340 IF X(I)<XL THEN XL=X(I)
350 IF XH<X(I) THEN XH=X(I)
360 IF Y(I)<YL THEN YL=Y(I)
370 IF YH<Y(I) THEN YH=Y(I)
380 NEXT I
390 PRINT"RECHECK DATA<Y,N>";: IN
PUT Q$
400 IF Q$<>"N" THEN 280
410 '
420 PRINT:PRINT" ..WORKING..":PR
INT
430 'SOLUTION OF SIMULTANEOUS
440 'EQUATIONS TO GET BEST FIT
450 '
460 FOR I=0 TO 2*M
470 FOR J=1 TO N
480 FC=ABS(X(J)^I)
490 IF(I/2-INT(I/2))>.01 THEN 53
0
500 IF I>0 THEN S(I)=S(I)+FC
510 IF I<=M THEN S2(I+1)=S2(I+1)
+FC*Y(J)
520 GOTO 550
530 IF I>0 THEN S(I)=S(I)+SGN(X(
J))*FC
540 IF I<=M THEN S2(I+1)=S2(I+1)
+SGN(X(J))*FC*Y(J)
550 NEXT J, I
560 '
570 'SOLUTION BY GUASSIAN
580 'ELIMINATION
590 '
600 C(1,1)=N
610 FOR A=1 TO M1
620 FOR B=1 TO M1
630 IF A=1 AND B=1 THEN 650
640 C(A,B)=S(A+B-2)
650 NEXT B
660 C(A,M2)=S2(A)
670 NEXT A
680 FOR I=1 TO M1
690 FOR J=M2 TO I STEP -1
700 C(I,J)=C(I,J)/C(I,I)
710 NEXT J
720 FOR K=M2 TO I STEP -1
730 IF I=1 THEN 780
740 FOR L=1 TO I-1
750 C(L,K)=C(L,K)-C(L,I)*C(I,K)
760 NEXT L
770 IF I=M1 THEN 810
780 FOR L=I+1 TO M1
790 C(L,K)=C(L,K)-C(L,I)*C(I,K)
800 NEXT L
810 NEXT K
820 NEXT I
830 PRINT:PRINT" COEFICIENTS:"
840 PRINT"*****"
850 FOR I=1 TO M1
```



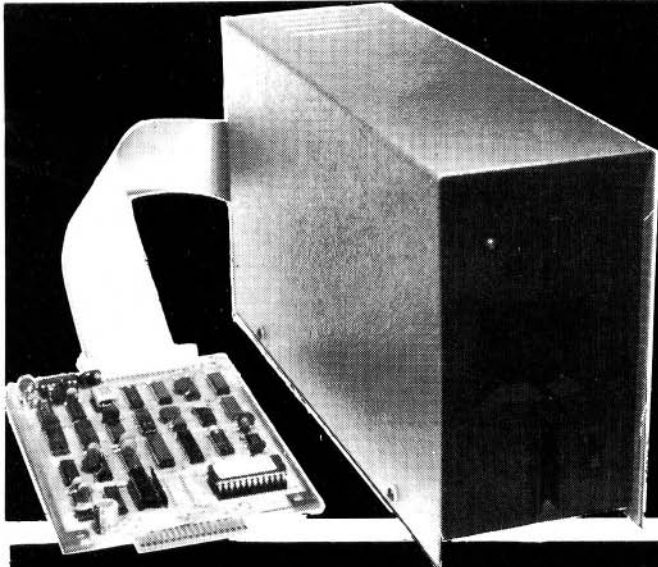

# "THE ALTERNATIVE" COLOR COMPUTER DISK SYSTEMS

**NOW ONLY 449<sup>95</sup>** 40 TRACK DRIVE **200 K BYTES**  
USER STORAGE

**NOW ONLY 549<sup>95</sup>** 80 TRACK DRIVE **400 K BYTES**  
USER STORAGE

## ROM SOFTWARE

A Full Featured  
Basic Compatible DOS

INCLUDES: TG-99 Disk Controller w/CCMD 9 DOS  
ROM • 40 Or 80 Track Disk Drive • Power Supply •  
Case • 2 Drive Cable • 9 Disk Utility Programs  
• CCEDT9 Disk Text Editor • Disk Text Processor I

Manufactured Under License From Tall Grass Technologies

## Editor / Assembler CO-RES9

CO-RES9 is a Co-resident Editor/Assembler that will allow you to create, edit and assemble machine language programs for the color computer. It will quickly and efficiently convert assembly language programs into machine code files. It will output machine object code to either cassette tape in a 'CLOADM' compatible format or directly to memory for direct execution.

**NOW ONLY**  
CO-RES9 editor/assembler tape  
w/manual ..... ~~\$39.95~~ **\$29.95**  
R.S. DISK EDITOR & ASSEMBLER Disk  
w/manual ..... ~~\$79.95~~ **\$49.95**

## TEXT Pro II

"The Professional's Word Processor"

### TEXT PROCESSOR FEATURES

- Character Fill
- Programmable Footer
- Right Justify Line
- Multiple Footnotes
- Three Indent Modes
- Three Programmable Headers
- Ten Programmable Tab Stops
- Margin Justification  
Left & Right
- Decimal Align, Center, Left &  
Right Justify on Tab Column
- Display & Input from Keyboard
- Change Formatting During  
Processing

### TEXT EDITOR FEATURES

- Single Keystroke Edit  
Command
- Append Files from Tape or Disk
- Fully Integrated Disk File  
Handler
- Edit or Process Files Larger  
Than Memory
- (No Conversion Required) Fully  
ASC II Compatible
- Full Featured Line Oriented  
Screen Editor
- Search and Replace Any  
Character Pattern
- Copy, Move or Delete Lines  
or Blocks of Text
- Edit Basic, Text or Assembler  
Files

**TEXT PRO II Features Over 70 Commands In All. Disk ... \$79.95**

## DATA PACK TERMINAL PACKAGE

- Full Text Buffering
- Terminal Baud Rates 300 To 9600 Baud
- Automatic Word Wrap Eliminates Split Words
- Full/Half Duplex
- Automatic File Capture
- Programmable Word Length, Parity & Stop Bits
- Automatic Buffer Size At Memory Limit
- Save & Load Text Buffer To Tape Or Disk
- Send Files Directly From Buffer Or Disk
- Full Disk Support For Disk Version
- Printer Baud Rates 110-4800
- Send Control Codes From Keyboard
- ASCII Compatible File Format



- Display On Screen Or Output Contents Of Buffer  
To Printer

We also have a disk version available called "DISKPACK." It includes all the commands mentioned plus commands for disk control. They include: Disk Load, Disk Save, Directory, Send Disk File and Kill Disk File. As usual all files are Basic Compatible ASCII formatted files which are also compatible with our Text Editor and Word Processor programs.

Datapack on tape w/manual ..... **\$24.95**  
Diskpack for R.S. disk w/manual ..... **\$49.95**  
Diskpack for CCMD 9 w/manual ..... **\$39.95**

5566 Ricochet Avenue  
Las Vegas, Nevada 89110



**(702) 452-0632**

All Orders Shipped  
From Stock  
Add \$2.50  
Postage



```

860 PRINT "C(";I-1;") = ";C(I,M2
)
870 NEXT I
880 PRINT"HIT ENTER TO GO ON.":I
NPUT Q$
890 PRINT:PRINT" ** ACCURACY OF
FIT **":PRINT
900 PRINT" PAIR X Y
CALC. Y"
910 PRINT" *****
*****"
920 FOR I=1 TO N
930 IN=X(I):GOSUB 1130
940 IF X(I)>999 OR Y(I)>999 THEN
PRINT USING " ## #.##^ ^ ^ #.##^
^ ^ #.##^ ^ ^";I,X(I),Y(I),YC EL
SE PRINT USING" ## ###.### ###.#
## ###.###";I,X(I),Y(I),YC
950 NEXT I
960 PRINT:PRINT"DO YOU WANT A PL
OT";:INPUT Q$
970 IF Q$<>"Y" THEN END
980 PRINT" THE DATA POINTS ARE C
IRCLES"
990 PRINT" AND THE PREDICTED CUR
VE IS "
1000 PRINT" THE SMALL DOTS. READ
Y";:INPUT Q$
1010 PMODE 4,1:PCLS:SCREEN 1,0

```

```

1020 FOR I=1 TO N
1030 IN=X(I):YC=Y(I):FL=1:GOSUB
1220
1040 NEXT I
1050 ST=(XH-XL)/100
1060 FOR IN=XL TO XH STEP ST
1070 GOSUB 1130
1080 FL=0:GOSUB 1220
1090 NEXT IN
1100 FOR I=1 TO 3000:NEXT I:END
1110 '
1120 'CALC. FIT ROUTINE
1130 YC=0:FOR J=0 TO M
1140 FC=ABS(IN^J)
1150 IF (J/2-INT(J/2))>.01 THEN 1
180
1160 YC=YC+FC*C(J+1,M2)
1170 GOTO 1190
1180 YC=YC+SGN(IN)*FC*C(J+1,M2)
1190 NEXT J
1200 RETURN
1210 'PLOT OUTPUT ROUTINE
1220 XP=250*((IN-XL)/(XH-XL))+2
1230 YP=140*(1-(YC-YL)/(YH-YL))+
20
1240 IF FL=1 THEN CIRCLE(XP,YP),
2 ELSE PSET(XP,YP,1)
1250 RETURN

```

## Marymae INDUSTRIES, INC.

In Texas, Orders,  
Questions & Answers  
1-713-392-0747

22511 Katy Freeway  
Katy (Houston), Texas 77450

To Order  
1-800-231-3680  
800-231-3681

### SAVE BIG DOLLARS ON ALL TRS-80® HARDWARE & SOFTWARE

TRS-80® by Radio Shack. Brand new in cartons delivered. Save state sales tax. Texas residents, add only 5% sales tax. Open Mon. - Fri., 9 - 6, Sat., 9 - 1. We pay freight and insurance. Come by and see us. Call us for a reference in or near your city. Ref: Farmers State Bank, Brookshire, Texas.

### WE OFFER ON REQUEST

Federal Express (overnight delivery)

Houston Intercontinental Airport  
Delivery, Same Day Service

U.P.S. BLUE—Every Day

References from people who have  
bought computers from us probably  
in your city. We have thousands  
of satisfied customers. WE WILL  
NOT BE UNDERSOLD!

**ED McMANUS**

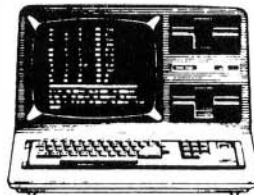

In stock TRS-80 Model  
II and III

No Tax on Out of Texas Shipments!

**Save  
10% 15%  
OR MORE**

Reserve your Model 16 Today!

TELEX: 77-4132 (FLEXS HOU)

### WE ALWAYS OFFER

We accept MasterCard, Visa and  
American Express cards

We use Direct Freight lines. No long waits

We always pay the freight and insurance

Toll free order number

Our capability to go to the giant TRS-80®  
Computer warehouse 5 hours away, in  
Ft. Worth, Texas, to keep you in stock.

\* TRS-80 is a Registered Trademark of Tandy Corp.

**JOE McMANUS**





FOR THE  
**COLOR  
COMPUTER/  
TDP100**

**COLOR CATERPILLAR** by the Rugby Circle, Inc. ©1983

An ecological system out of control; the last survivors ban together in the valley. Of the predator insects, the caterpillar remains as the worst menace because of its amazing ability to reproduce. From your mobile post, your guns are aimed at the moving target: a raging caterpillar splits in two with each half going in opposite directions. Even if, in your persistence, you manage to destroy the creature, another one appears one segment longer than the previous caterpillar. Adopting to its hostile environment, if the caterpillar reaches the valley below without attacking you, he transforms into a killer moth. Your survival instincts are not nearly so advanced as those of your foe.

Snatch up this survival epic. A challenging fast-action, Machine language, arcade-style game. You'll need plenty of practice. Rated the best arcade simulation of its type. Requires 16K memory for the cassette version. . . . . Only **\$19.95**

**DEATH TRAP** the Rugby Circle, Inc. ©1983

To satisfy your insatiable hunger for wealth, you have set out to explore the ancient ruins of a lost civilization. Protected by your armor-plated tank, you amble through the twisted remains searching for hidden treasures. As you explore the complicated Death Trap which extends far beyond the horizon, your energy supply continually diminishes forcing you to consume the existing fuel mines. Barring your path are various deterrents which, among other things, destroy tanks, award points, supply maps, and teleport your tank to unknown regions of the Death Trap.

Death Trap is a totally unique concept. It is a hybrid game employing the graphics of an arcade game and the excitement of an adventure game, yet requiring the concentration of a strategy game. A great investment! You'll never tire of exploring the immense, seemingly endless maze, and you can look forward to a number of new Death Trap mazes in the future! Requires 16K memory and is written entirely in Machine language. . . . . Only **\$19.95**

**ETT (Electronic Typing Teacher)**

Learn the RIGHT WAY — FAST!

Video Keyboard Guides Beginners —

- Finger Exercises SHOW & TEACH every Finger-Letter combination
- Self-Tests Help Beginners & Challenges Experts!
- 10 Page Student Manual & Self Study Course
- Hundreds of Practice Sentences
- 19 Skill-Building Practice Sets as DATA FILES
- Create your own data files for your own usage

Written by a Certified Teacher and a Professional Programmer. For the Radio Shack® & TDP-100® Color Computers. Requires 16K minimum and Extended BASIC. If you need to learn to type, don't miss this super program. . . . . Only **\$19.95**

**MASTER CONTROL II — New & Improved!**

Copyright ©1982 Soft Sector Marketing, Inc. Written by Alan Schwartz. TAKE CONTROL . . . OF BASIC PROGRAMMING ON YOUR TRS-COLOR OR TDP100 MACHINE.

Master Control is a Machine language program designed to increase the speed in which it takes to write BASIC programs, by providing the most commonly used program statements with two(2) keystrokes rather than having to type the entire command. The program is relocatable and can be placed anywhere in memory, normally the top 1616 bytes of RAM, it will work on 16K and 32K systems. All of the instructions are compatible with the Radio Shack Disk Controller.

**OVERVIEW**

1. 51 preprogrammed command keys of standard and Extended BASIC commands.
2. Direct control of motor, trace and audio functions.
3. Relocatable Machine code, now works with disk systems.
4. Automatic line numbering, starting point and increment are alterable.
5. Programmable customkey, you can select your own special function.
6. Direct run key, run the program as you write it.
7. Plastic keyboard overlay for easy program use.
8. Easy entry of commands into program statements.
9. New, complete, easy to understand instruction manual.
10. Repeat keyboard function on all keys.

Requires 16K. Does not require Extended BASIC (Extended BASIC is required for some functions.)

**Introductory Offer — Cassette #0-79 \$19.95**

**ATTENTION PRESENT OWNERS OF MASTER CONTROL —**

If you have the original MASTER CONTROL program, you can update to the newest version for only **\$8.00 plus shipping** and handling. To get this low cost update do the following:

- 1) Remove the corner of your old foil overlay that has the words MASTER CONTROL on it.
- 2) Paste it to a piece of paper.
- 3) Send this piece of paper and your original MASTER CONTROL tape with **\$8.00** for the update and \$2.00 for shipping and handling to:

Master Control Update  
c/o Soft Sector Marketing, Inc.  
P.O. Box 340  
Garden City, Michigan 48135

We must have all the above to process your update.

**COLOR GRAPHICS EDITOR**

©1983 Soft Sector Marketing, Inc. Written by Larry Ashmun.

AT LAST, a graphics drawing program that is USEFUL in writing programs that use graphics.

This program permits the creation of graphic pictures on the screen that can be saved to disk in the form of DATA STATEMENTS, for DISK BASIC, or in the form of FDB STATEMENTS, for use with a disk based Editor/Assembler (eg. MICRO WORKS MACRO 80C). It allows two type of data entry, testing of animation effects and many additional features.

Written in Machine language, requires Extended BASIC or RS Disk BASIC and a minimum of 16K of memory. Works with cassette or disk. . . . . Cassette #0-211 **\$19.95**

**OKI-PRINT** ©1983 by Craig Edelheit

DUMP SCREEN GRAPHICS FROM YOUR RADIO SHACK TRS-80® OR TDP100® COLOR COMPUTER TO AN OKIDATA MICROLINE 82A SERIAL DOT MATRIX PRINTER 256 x 192 HIGH RESOLUTION.

OKI-PRINT is a BASIC language program that is designed to do high resolution screen dumps from a Radio Shack or TDP100 Color Computer, to an Okidata 82A printer. OKI-PRINT will dump any PMODE MP (M = MODE, P = PAGE) If the PMODE is 1 or 3 (which are color modes) the printer will attempt to shade the different colors in lighter and darker intensities of black in order to make them more recognizable. Requires 16K Extended BASIC.

Cassette #0-23 **\$12.95**

**SSM** SOFT SECTOR MARKETING, INCORPORATED

6250 Middlebelt • Garden City, Michigan 48135  
Order Line **800-521-6504**  
Michigan Orders & Questions 313-425-4020



**PAYMENT**—payment accepted by charge, personal check or C.O.D. only, under the following conditions: **Charges** processed when shipped, usually within 48 hours. **Personal Checks** delay shipping, pending 3 weeks to clear. **C.O.D.**

orders are certified check or cash only, add \$1.50. MI residents must add 4% sales tax. **SHIPPING & HANDLING — Shipping Charges:** Send the larger amount, 2% or \$2.50, unless stipulated otherwise. Any order received without shipping and handling will be shipped **freight collect Air Mail Shipping** outside of North America, please send the larger amount, 10% or \$10.00. Overpayment will be refunded.

## Arcade-Style *Gazon* Is Vidiots Delight

Being a video game junkie, or *vidiot*, I love to play fast arcade-like games on my CoCo. *Gazon* is a fun game that is bound to become a favorite of the arcade game players.

*Gazon* is a machine language program that requires 16K Extended BASIC. It comes with a short instruction sheet that tells you how to load and execute the program, start the game, and how to play another game.

After executing the program, simple playing instructions start to scroll up the screen in high resolution characters. You can select from three levels of play, Easy, Medium, and Hard. You use the right joystick to fire and move your ship, which looks like a flying saucer.

It's best to start on the Easy level to get the feel of the game. On Medium, *Gazonians* get smarter and start avoiding you. On the Hard level you also fire slower, which makes things more interesting.

The object of *Gazon* is to protect your 13 supply pods in the center, for as long as you can, while the *Gazonians* try to steal them. The man-like aliens die when you shoot them, but the only way to kill the oval-shaped ones is to run them over.

When you kill a *Gazonian* carrying a pod, the pod is deposited in the last space occupied by it. The pods cannot be destroyed and the *Gazonians* always seem to find them. The man-like aliens start out worth 10 points, but after about a minute of play, this increases to 20, then 30, and so on. The oval-shaped aliens are always worth 100 points.

My only criticism of *Gazon* is that you can only fire in eight directions and you cannot move and fire at the same time, but this seems to be true of most arcade-like games.

A couple of interesting features are also included. After a certain number of replays, the colors of everything change, including the instruction screen. It also keeps track of the high score for each of the three levels of play. Most of the other arcade-like games I have played only keep track of one high score.

All in all, *Gazon* would be a pretty good buy for anyone who enjoys arcade-like games.

(K & K Computerware, 37326 Gregory Drive, Sterling Heights, MI 48077, \$15.95 on tape or \$19.95 on disk)

—Dennis Reiter

Hint . . .

## Junk Eraser

Here's an easy way to end many tape I/O errors. Position tape where program is to be saved. Then press play and record, and type in *MOTOR ON*. Estimate the length of your program, add a few seconds more, and type *MOTOR OFF*. Rewind to original position, and save in normal way.

This will erase any unwanted junk on the tape, thus allowing a clean saving process.

Dan Rowe  
Harrah, WA

## ™ TRS80 color

From the January 1981 issue of the CSRA Computer Club newsletter:

There was some amusement at the November meeting when the Radio Shack representatives stated that the software in the ROM cartridges could not be copied. This month's 68 Micro Journal reported they had disassembled the programs on ROM by covering some of the connector pins with tape. They promise details next month. Never tell a hobbyist something can't be done! This magazine seems to be the only source so far of technical informations on the TRS-80 color computer\*. Devoted to SS-50 6800 and 6809 machines up to now, 68 Micro Journal plans to include the TRS-80 6809 unit in future issues.

NOTE: This and other interesting and needed articles for the Radio Shack TRS-80 color computer™ are being included monthly in 68 Micro Journal—The Largest specialty computer magazine in the world!

### 68 MICRO JOURNAL

5900 Cassandra Smith Road  
Hixson, Tennessee 37343  
615 842-4600

#### Subscription Rates

USA: 1-year \$24.50; 2-year \$42.50; 3-year \$64.50  
CANADA and MEXICO: Add \$5.50 per year to USA Price  
Foreign Surface: Add \$12.00 per year to USA Price  
Foreign AIRMAIL: Add \$36.00 per year to USA Price

\*\* Sample issue - \$3.50



68 Micro Journal™ was established with one objective in mind; to provide a Magazine FOR 68xx Users BY 68xx Users. Because of a strict advertiser policy, 68 Micro Journal™ has gained a strong following WORLDWIDE because the reader KNOWS what he is getting when purchasing from a 68 Micro Journal™ Advertiser. It has gained a strong User following because most of the material published is contributed BY USERS, and, therefore, is relevant to the Users needs.

Currently, and even before the Color Computer™ hit the stores, 68 Micro Journal™ was devoting more space to the TRS-80C Color Computer™ and information concerning the Motorola 6809 (which is the CPU in the Color Computer™) than ANY OTHER Computer Magazine. Examples include:

**REVIEWS** of the three major Disk Control Systems for the Color Computer™, most of the Monitors, Assemblers, and Disassemblers, Word Processors and Editors, "Terminal" Programs (for use with Modems, Communications with other Computers, etc.), and of course, Games.

**HINTS** for Expanding Memory, Power Supply Cooling, repairing sticky keyboards, disabling the ROM PAK "Take Over", hooking up to Printers, etc.

**DISCUSSIONS** of the 6883 Synchronous Address Multiplexer, using the Color Computer™ with 64K and 96K memory (which it is ALREADY capable of handling), thoughts on Programming, etc.

I suggest that you subscribe to 68 Micro Journal™, SOON, as many back issues are sold-out.

We still, and will continue to, lead in the type information you need to FULLY UTILIZE the POWER of the 6809 in the Radio Shack TRS-80 Color Computer™.

*Bob Nay*  
Bob Nay  
Color Computer Editor

# THESE FINE STORES CARRY THE RAINBOW

The retail stores listed below carry **the RAINBOW** on a regular basis and may have other products of interest to Color Computer users. We suggest you patronize those in your area.

**Abacus Computers**  
S. Holland, Mich.

**Accolade Distributors**  
San Diego, Calif.

**Acorn Computer Systems**  
Wauwatosa, Wisc.

**Acme Book Co.**  
Baton Rouge, La.

**A Computer Store**  
Indianapolis, Ind.

**Act One Video**  
Marietta, Ga.

**Adventure International Store**  
Longwood, Fla.

**All-Pro Souvenirs**  
Pittsburgh, Pa.

**All Systems Go**  
Orlando, Fla.

**Alonso Book & Periodical**  
Alexandria, Va.

**Amateur Radio Equipment Co.**  
Wichita, Kan.

**Anderson Electronics**  
Benton, Ky.

**Appalachian Computing**  
Kingwood, W. Va.

**AppleTree Computers**  
Dekalb, Ill.

**Atlantic News**  
Halifax, N.S.

**Audio Concepts Unlimited**  
Denton, Tex.

**Aurora Newsland**  
Aurora, Col.

**Bauer Electronics**  
Lawrenceburg, Ind.

**B. Dalton Booksellers**  
West Jackson St. - Chicago, Ill.  
N. Walbush St. - Chicago, Ill.  
Milwaukee, Wisc.  
Peoria, Ill.

**Begley Drugs**  
Crestwood, Ky.

**B.I.E.S. Systems**  
Oak Park, Ill.

**Bils, Bytes & Nibbles**  
Spokane, Wash.

**Bill's TV Radio Shack**  
Newton, Ill.

**Bob's In Newtown**  
Chicago, Ill.

**Bob's News Emporium**  
Chicago, Ill.

**Bob's Rogers Park**  
Chicago, Ill.

**Book Market**  
East Cedar - Chicago, Ill.  
North Cicero - Chicago, Ill.  
West Diverser - Chicago, Ill.  
Peoria, Ill.  
Champaign, Ill.  
Danville, Ill.

**Book Nook**  
Lisle, Ill.

**Book Tree**  
Milwaukee, Wisc.

**Booked Solid**  
Milwaukee, Wisc.

**Booked Solid II**  
Milwaukee, Wisc.

**Bookland, Inc.**  
Indianapolis, Ind.

**Book World**  
Janesville, Wisc.

**Buffalo Technologies**  
Amherst, N.Y.

**Byte By Byte**  
Utica, Mich.

**Campus Computer Corp.**  
Nashville, Tenn.

**C&J Electronics Computer Center**  
Richland, Wash.

**C/C Computer Systems**  
Owosso, Mich.

**Capitol Microcomputers**  
Austin, Tex.

**Caribbean Engineering Corp.**  
Stuart, Fla.

**Caves Books Co.**  
Hong Kong

**Chattanooga Choo-Choo**  
Chattanooga, Tenn.

**Chester Electronic Supply**  
Kenosha, Wisc.

**Chicago-Main News**  
Evanston, Ill.

**Chips, Inc.**  
Atlanta, Ga.

**CMD Micro**  
Edmonton, Alta.

**Coast Electronics**  
Morro Bay, Calif.

**Cole's Computer Center**  
San Antonio, Tex.

**Color Computing**  
Southgate, Calif.

**Color Software Center**  
Cincinnati, Ohio

**Community News Center**  
Ann Arbor, Mich.

**Compulit**  
Burnaby, B.C.

**Computer Center**  
Albuquerque, N.M.

**The Computer Center**  
New York, N.Y.

**The Computer Center of York**  
York, Pa.

**The Computer Connection**  
Boulder, Col.

**Computer Corner**  
Lapeer, Mich.

**The Computer Experience**  
Greenwood, Ind.

**Computer Shack**  
Pontiac, Mich.

**The Computer Store**  
Louisville, Ky.

**The Computer Store**  
Phoenix, Ariz.

**The Computer Store**  
San Diego, Calif.

**The Computer Store**  
Tulsa, Okla.

**The Computer Store**  
Casper, Wyo.

**Computer Resource**  
Williamsburg, N.Y.

**CompServ of Danbury**  
Danbury, Conn.

**Computer Concerns**  
Havlock, N.C.

**Computer Services**  
Lawrenceburg, Ind.

**Computer SOS**  
Shreveport, La.

**Computer Town**  
Coral Springs, Fla.

**Computers 'N' Stuff**  
Duncan, Okla.

**Computerware Store**  
Encinitas, Calif.

**Computerworx**  
Knoxville, Tenn.

**Cosmos Computers**  
Bettendorf, Iowa.

**Crouchel Electronics**  
Conroe, Texas.

**Cudahy News & Hobby**  
Cudahy, Wisc.

**Dallas Computer Center**  
Dallas, Tex.

**Data Barn**  
Renton, Wash.

**Data Byte Computer Center**  
Beaufort, S.C.

**Data Concepts**  
Scottsdale, Ariz.

**Data Domain**  
Schaumburg, Ill.

**Data Equipment Co.**  
Downey, Calif.

**Data Link**  
Dayton, Ohio

**The Data/Phile Co.**  
East Syracuse, N.Y.

**Dave's Elect. Radio Shack**  
Pensilvania, N.J.

**D. Data**  
Stillwater, Okla.

**Deiker Electronics**  
Smyrna, Tenn.

**Disney's Electronics**  
San Diego, Calif.

**Dimensional Software**  
San Diego, Calif.

**Eldon Doucet**  
Angus, Ont.

**DSL Computer Products**  
Dearborn, Mich.

**E. B. Garcia & Associates**  
Chicago, Ill.

**The Eight Bit Corner**  
Muskegon, Mich.

**Electrobrain**  
Atwater, Calif.

**Electronic World**  
Fairbanks, Alaska

**Elex Mart**  
Jasper, Ind.

**F.M. Electronics**  
Jay, Maine

**Final Edition**  
University City, Mo.

**The Floppy Disk**  
Downey, Calif.

**Frank Hagg Laboratory**  
Syracuse, N.Y.

**Galls Book World**  
Hamilton, Ont.

**Game Preserve**  
Indianapolis, Ind.

**Gopher Hole**  
Brooklyn Center, Minn.

**The Green Dragon**  
N. Charleston, S.C.

**Guild Books and Periodicals**  
Chicago, Ill.

**Guild News Agency**  
Atlanta, Ga.

**Gulliver's Inc.**  
Hays, Kan.

**Gus-Stan Enterprises**  
Pikeville, Ky.

**H&H Co.**  
Whitehorse, Yukon

**H&H Electronics**  
Woodward, Okla.

**Hands On Computer**  
Atlanta, Ga.

**Hawley-Cook Booksellers**  
Louisville, Ky.

**Hathaway's Magazines**  
Colorado Springs, Col.

**Hi-Fi Audio Co.**  
Owosso, Mich.

**Hobby Shop**  
Hopkinsville, Ky.

**Home Computer Store**  
Westerville, Ohio

**Home Brew Computers**  
Phoenix, Ariz.

**The Homing Pigeon**  
Elgin, Tex.

**Howson's**  
Joplin, Mo.

**Hurley Electronics**  
Santa Anna, Calif.

**HW Electronics**  
Northridge, Calif.

**Independent Computer Systems**  
Winter Park, Fla.

**Indiana News**  
Indianapolis, Ind.

**Interstate Distributors**  
Billings, Mont.

**J&J Electronics Ltd.**  
Winnipeg, Man.

**John's News Stand**  
Medford, Ore.

**K&S News Stand**  
Winston-Salem, N.C.

**Kona Recreation**  
Kailua-Kona, Hawaii

**Kelly Software Distributors**  
Edmondton, Alta.

**Kroch's & Brentano's**  
South Walbush - Chicago, Ill.  
West Jackson, Chicago, Ill.  
835 N. Michigan - Chicago, Ill.  
516 N. Michigan - Chicago, Ill.  
Oak Park, Ill.

**L&R Electronics**  
Grant's Pass, Ore.

**Lakewood International News**  
Lakewood, Ohio

**Leo's Book & Wine Shop**  
Toledo, Ohio

**Level IV Products**  
Livonia, Mich.

**Levity Distributors**  
Hollywood, Calif.

**Libra Books**  
Eugene, Ore.

**Little Professor Book Center**  
Philadelphia, Ohio

**Radio Shack**  
Canton, Ohio

**Lloyd's Radio**  
Wichita, Kan.

**M&D Distributing**  
Houston, Tex.

**Madison Books**  
Madison, Ala.

**M&W Electronics**  
Harrodsburg, Ky.

**Magnum Computer Products**  
Boise, Idaho

**Merit Micro Software**  
Oklahoma City, Okla.

**Micro Byte**  
Miami, Fla.

**Microcomputer Software Center**  
Manchester, N.J.

**Micro Con Software Cntr.**  
Watour, Mass.

**Microwest Distributors**  
N. Vancouver, B.C.

**Micro World II**  
Clinton, N.J.

**Mike's Electronics Distributor**  
P.L. Lauderdale, Fla.

**Mill's Book Store**  
Nashville, Tenn.

**Milting's Electronics**  
Walbush, Ind.

**Steven Moreno**  
Stockton, Calif.

**Mosko's Book Store**  
Nashville, Tenn.

**Multi-Mag**  
London, Ont.

**The News Rack**  
Miami, Fla.

**News-Readers**  
Fairborn, Ohio

**Newsy**  
Philadelphia, Pa.

**Ninis Corner, Inc.**  
Cambridge, Mass.

**NORMAR**  
Wilmington, Del.

**Nybbles 'N Bytes**  
Tacoma, Wash.

**OPAMP Technical Books**  
Los Angeles, Calif.

**Out Of Town News**  
Cambridge, Mass.

**Parwest Books**  
Chicago, Ill.

**Parkway Drugs**  
Chicago

**PCLER80**  
Mansfield, Ohio

**Perry's News Shop**  
Avondale, Pa.

**Personal Computer Place**  
Mesa, Ariz.

**Personal Software**  
Malvern, Pa.

**PIH Computer & Software**  
Pleasant Hills, Pa.

**Poling Place**  
Pinellas Park, Fla.

**South Pasadena, Fla.**

**Portsmouth Computers**  
Roffmouth, N.H.

**Printers, Inc.**  
Palo Alto, Calif.

**Prism Software**  
Kincardine, Ont.

**Pro Am Electronics**  
Pacific Beach, Calif.

**Pro Electronics**  
Wayzata, Mich.

**The Program Store**  
Baltimore, Md.

**Cambridge, Mass.**

**Columbus, Ohio**

**Falls Church, Va.**

**Greensburg, Pa.**

**Kensington, Md.**

**Washington, D.C.**

**Programs Plus**  
Tulkuwa, Wash.

**Programs Unlimited**  
Mayfield Heights, Ohio

**Prospect News & Magazines**  
Milwaukee, Wis.

**Quality Technology**  
Salt Lake City, Utah

**Radio Shack F756**  
Artesia, N.M.

**Radio Shack**  
El Cajon, Calif.

**Radio Shack**  
Freehold, N.J.

**Radio Shack**  
Martinsville, Ind.

**Radio Shack**  
Paducah, Ky.

**Radio Shack**  
Peace River, Alta.

**Radio Shack**  
Petersborough, N.H.

**Radio Shack**  
Salina, Kan.

**Radio Shack**  
San Diego, Calif.

**Radio Shack of Scottsburg**  
Scottsburg, Ind.

**Radio Shack 7181**  
Sidell, La.

**Radio Shack**  
Waterboro, Maine

**Radio Shack & Elec. Hut**  
Kissimmee, Fla.

**Rainbow Software Services**  
Calgary, Alta.

**R&V Sound**  
Fortuna, Calif.

**Recycle Computers**  
Houston, Tex.

**Read-More News**  
Minneapolis, Minn.

**RFI Electronics**  
Ft. Worth, Tex.

**Reliz Electronics**  
Toledo, Ohio

**Road Runner Computer Products**  
Glendale, Ariz.

**Robbins Electronics**  
Durand, Mich.

**John Rollins**  
Kalamazoo, Mich.

**Sail of the Earth**  
Abuquerque, N.M.

**Sandmeyer's Bookstore**  
Chicago, Ill.

**Harry Schwartz Bookshop**  
Milwaukee, Wisc.

**Selectronics**  
Riverside, Calif.

**Sewing Center**  
Orlando, Fla.

**Seonen & Wilmoth Books**  
Clearwater, Fla.

**Soft Sector Marketing**  
Garden City, Mich.

**Software Access**  
Living, Tex.

**Software 'n' Suds**  
E. Windsor, N.J.

**Soft Shop**  
Yuma, Ariz.

**Software Atlanta**  
Atlanta, Ga.

**Software Center**  
Warrick, R.I.

**Software Centre**  
Torrance, Calif.

**Software City**  
Exton, Pa.

**Software Plus**  
Fairview, N.J.

**Midland Park, N.J.**

**Montvale, N.J.**

**Pinebrook, N.J.**

**River Edge, N.J.**

**Summit, N.J.**

**Teaneck, N.J.**

**Software Concepts**  
Dallas, Tex.

**Software Connection**  
Ft. Lauderdale, Fla.

**Software, Etc.**  
Houston, Tex.

**Software, Etc.**  
Wenatchee, Wash.

**Software 1st**  
Santa Rosa, Calif.

**Software Plus**  
Citrus Heights, Calif.

**Software Shop**  
Mansfield, Mass.

**Software Station**  
Rockaway, N.J.

**Software Store**  
Tampa, Fla.

**The Software Store**  
Rockville, Md.

**Software Unlimited**  
Tucson, Ariz.

**Software Unlimited**  
Orlando, Fla.

**Sound Trader & Computer Center**  
Tampa, Fla.

**Sound Video Ltd.**  
Niles, Ill.

**Spectrum Projects**  
Woodhaven, N.Y.

**Stirling Book Center**  
Sterling Heights, Mich.

**Stevens Radio Shack**  
Phoenixville, Pa.

**Strawflower Electronics**  
Half Moon Bay, Calif.

**Tabacco Corner Newsroom**  
Memphis, Tenn.

**T. M. Computers**  
Kingston, Ont.

**Total Circulation Services**  
New York, N.Y.

**Trade 'N Books**  
Montgomery, Ala.

**Tri-Count Electronic Radio Shack**  
Fenton, Mich.

**Tri-Tek Computers**  
Phoenix, Ariz.

**Unilex Software**  
Crown Point, Ind.

**Unicom Electronics**  
Johnson City, N.Y.

**University of Chicago Bookstore**  
Chicago, Ill.

**University of Illinois Bookstore**  
Chicago, Ill.

**University of Wisconsin Bookstore**  
Milwaukee, Wisc.

**Videomart, Inc.**  
Chicago, Ill.

**Village Green**  
Rochester, N.Y.

**Village Computer & Software**  
Cedar Knolls, N.J.

**Wayne Software**  
Wayne, N.J.

**Wholelife Dist.**  
Denver, Colo.

**Wike News**  
Dayton, Ohio

**Wilmington, Ohio**

**Willy's Electronics**  
National City, Calif.

# RAINBOWfest

Regency-Hyatt Woodfield Chicago April 22-24



# ADVERTISER'S INDEX

We encourage you to patronize our advertisers—all of whom support the TRS-80 Color and TDP System-100 computers. We will appreciate your mentioning the **RAINBOW** when you contact these firms.

Aardvark 80 .....	201	Delker Electronics .....	41	Nanos Systems Corp.....	205
All American Ultra-Light Industry .....	107	Desert Press, Inc .....	64	Nelson Software Systems .....	10, 11, 15, 176, 177
All Color Software .....	192	Desert Software .....	19	New Salem Research .....	26
AMDEK Corp.....	9	Dorsett Educational Systems .....	30	Oelrich Publications .....	52
A. M. Hearn Software .....	102	Double Density Software .....	115	Owl-Ware .....	182
American Library & Info Services .....	207	DSL Computer Products .....	193	Parsons Software .....	152
Anteco.....	57	Dugger's Growing Systems .....	40	PClear4 Co.....	208
Arizin .....	51	Dymax .....	72	PCLEAR 80 .....	142
Arizona Discount Software ..	122	Dynamic Electronics .....	32	Peacock Enterprises .....	110
Ark Royal Games .....	169	Educational Programming Service .....	76	Petrocci Freelance Associates .....	63
Armadillo International .....	231	80-U.S. Journal .....	233	Platinum Software .....	195
Aurora Software .....	42	Elite Software .....	109	Prickly-Pear Software .....	43, 94, 173
B.C. Engineering .....	62	Emerald Computer Service .....	111	Prism Software.....	71
Basic Programs.....	223	Endicott Software .....	185	The Program Store .....	55
Basic Technology .....	145	Erickson, B. ....	22, 150	The Programmer's Guild .....	149
Bear Bones Software .....	235	F & T .....	139	The Programmer's Institute .....	133
Bertamax .....	33	Federal Hill Software .....	204	Pyramid Distributors .....	46, 83
Better Software.....	13	Freeland Engineering .....	134	Q-Soft .....	194
B5 Software .....	54	Genesis Software .....	236	Quasar Animations .....	189
Botek Instruments .....	47	Greentree Software .....	179	Radio Shack .....	25
Bruck Associates .....	104	Harmonycs .....	117	Rainbow Connection Software .....	221
Bumblebee Software .....	211	Hawkes Research Services.....	50	RAINBOWfest .....	147
Calc-Soft.....	68	HIB Software .....	108	Rainbow On Tape .....	232
Cer-Comp .....	237	Frank Hogg Laboratory .....	37, 38, 39	Real Software .....	224
Chattanooga Choo-Choo Software .....	98	Home Base Systems.....	131	S & S Arcade .....	69
Chromasette .....	199	HYCOMP Software .....	160	SDS Computers .....	156
Circle City Software .....	196	Illustrated Memory Banks .....	203	SP Software .....	35
Classical Computing .....	89	Ilume Design .....	175	Selected Software .....	187
CoCo Data Enterprises .....	184	Intellectronics .....	171	Shantronics .....	168
CoCo Hut .....	220	Inter+Action .....	186, 229	Snake Mountain Software .....	225
CoCo Pro .....	105	International Software .....	165	Soft City .....	167
CoCo Warehouse .....	87	Intracolor .....	137	Soft Sector Marketing .....	239
Cognitec .....	215	International Color Computer Club.....	143	Software Options .....	29
Color Computer Weekly.....	148	Intronics .....	174	Software Shop.....	92
Color Software Services .....	49, 163, 222	JARB Software .....	191	Softwide.....	190
Color Soft Software .....	202	JPC.....	180	Southern Software .....	58
Comp-U-Kids .....	138	Kalglo Electronics .....	97	Spectral Associates .....	93, BC
Compukit .....	70	K&K Computoware .....	209	Spectrum Projects .....	151, 153, 154, 155, 157, 159, 161
Computer Accessories of Arizona .....	217	KRT Software .....	80	Speech Systems .....	95
The Computer House .....	14	Land Systems .....	77	Star-Kits .....	141
Computer Island .....	213	Leader Sales Corporation .....	66	Hoyt Stearns Electronics .....	118
Computer Plus .....	3	Mark Data Products .....	166, 181, 183	Sugar Software .....	129
Computer Shack ..	119, 120, 121	Martin Consulting .....	21	Superior Graphic Software.....	103
Computer Systems Center ..	31	Marymac Industries .....	238	Superior Oracle Software .....	146
Computerware.....	197	Med Systems Software .....	85	T & D Software.....	101
Control Craft, Inc .....	23	Micro Catalog .....	18	Tabby Enterprises .....	81
Crimson Software .....	24	Micro-80 .....	72, 126	TASADA .....	36
Custom Software Engineering .....	67	Micrologic .....	123	TEKSYM Corp.....	140
Data-Comp .....	206, 240	Micronix .....	65	Transformer Technologies... ..	116
Dataman .....	99	Micro-Products Division.....	91	Transition Technology .....	212
Datasoft .....	17	Micro Technical Products.....	132	Washington Computer Services.....	144
Debug .....	183	The Micro Works .....	125	York-10 .....	53
		Tom Mix Software .....	27, 73, 173	Zeta Software .....	135
		Moreton Bay Laboratory ..	100, 214		
		Moses Engineering.....	114		



FAST, EFFICIENT  
MACHINE LANGUAGE

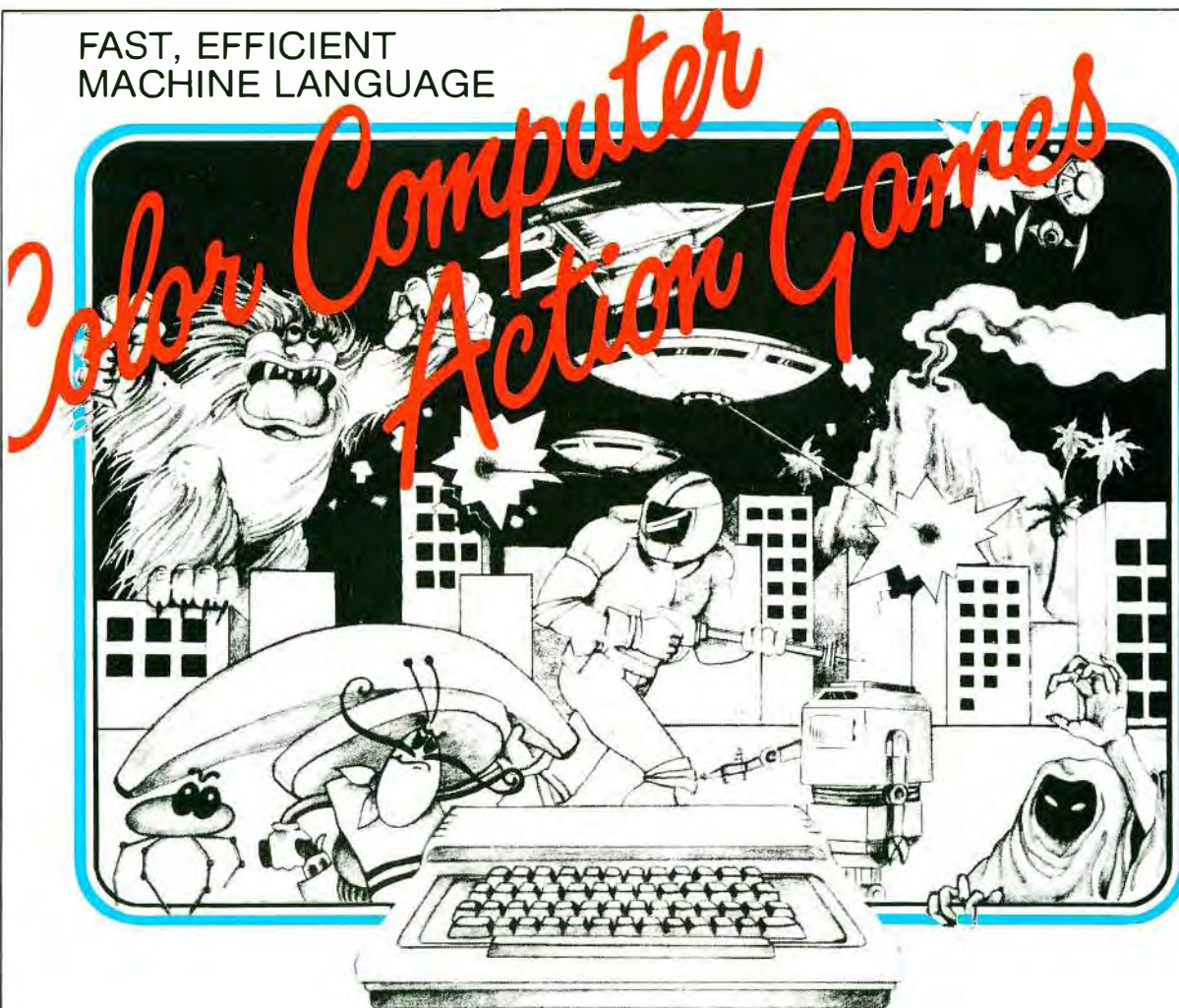

### **NEW ARCADE GAMES**

GLAXXONS / EL BANDITO / COSMIC CLONES

### **ARCADE GAMES**

HAYWIRE / ASTRO BLAST / CAVE HUNTER / SPACE RAIDERS  
ARCADE GAMES, CASSETTES 24.95—REQUIRE 16K / DISC 29.95—REQUIRES 34K

### **ADVENTURE GAMES**

CALIXICO ISLAND / THE BLACK SANCTUM  
ADVENTURE GAME CASSETTES 19.95—REQUIRES 16K

***BUY FROM YOUR FAVORITE DEALER OR DIRECT FROM***

MARK DATA PRODUCTS  
24001 ALICIA PKWY., NO. 226, MISSION VIEJO, CA 92691 • (714) 768-1551

We pay shipping on all orders in the continental U.S. and Canada. Overseas add \$3.00. California residents, please add 6% sales tax. We accept MasterCard and VISA. We are always looking for quality machine language programs. Contact us for details.



*Mark Data Products*



# SPECTRAL ASSOCIATES

16K Arcade Quality Games  
For TRS-80 Color Computer

Only  
\$21.95

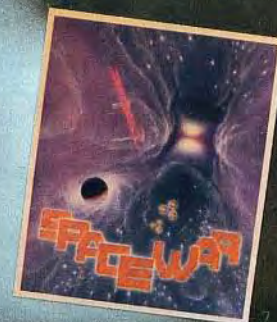
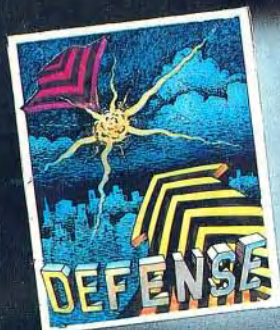

SPECTRAL ASSOCIATES, 141 HARVARD AVE., TACOMA, WA. 9846

**BEST SELECTION ANYWHERE**

GREAT UTILITIES

FLEX+ DOS

BEST EDITOR/ASSEMBLER

SUPER MACHINE LANGUAGE GAMES

FANTASTIC BASIC GAMES

BOOKS

TOLL FREE FOR ORDERS ONLY: 1-800-426-1830 8:30-4:30 P.S.T.

Except WA, AK, HI

BUSINESS OFFICE: 206-565-8483

We accept VISA, MASTERCARD, AMERICAN EXPRESS.

Add 3% for shipping. NO C.O.D. All prices U.S. FUNDS.

To find out about our other products, write or call for catalog.