

OS-9 Newsletter®

Volume V Issue 7

Bellingham OS-9 Users Forum

July 31, 1994

OS-9 Level one on your IBM ?

CoCo-2 emulation software available **FREE** for your IBM-PC (286, 386, 486). Download it now from an OCN Regional Libraries and on Internet: *wuarchive.wustl.edu*. The file is called *CoCo.EXE* and has been evolving. Here is a short list of what you can expect to see in the next upgrade, within the next couple of months.

Some of the features already written into the latest Version 1.40:

- SoundBlaster support with volume control
- Game port joystick support
- Read/write real CoCo disks from within the emulator (rather than having to use virtual disks, though they are also still available)
- Improved recognition of artifacting modes
- Supports non-standard graphics modes
- Load snapshots at the MS-DOS prompt with "COCO snapshot"
- RETRIEVE, DSKINI, and emulator now support up to 80-track disks
- elect the disk's side with RETRIEVE and DSKINI; 1.2Mb drive calibration bug now fixed
- Keyboard layout customizer option
- Improved printer support: 8-bit capable, adding Fs to CRs is now optional, and the printer output can be disabled
- Cold restart option; warm reset now the more convenient SHIFT-F10
- A new option in the Options Menu to shell to the MS-DOS prompt without ending an emulator session
- Selectable interrupt frequency: 50Hz or 60Hz
- Optional ROM patch for Disk BASIC adds new commands LOADX, SAVEX, DIRX, LOADXM, SAVEXM, KILLX, DOSX to access files residing in your MS-DOS

directory. (DOSX is equivalent to the Quit option.)

- A new opcode which allows 6809-based programs to call 8086 code from within the emulator. (That's how the X commands access your MS-DOS directory.)

Other options I'd like to add:

- Built-in file import/export menu
- Ability to use Disk BASIC's DSKINI from within the emulator to format virtual or real disks
- Ability to retrieve CoCo II ROMs out of a CoCo III. They're in there, but not normally accessible
- CoCo III features??????

Actually, I may hold out some of the advanced disk features (e.g. direct access) for the shareware version, but I haven't decided yet. Anyway, just a note to let everyone know what's going on

==Jeff Vavasour==

*** IN THIS ISSUE ***

| | |
|--|---------------|
| COCO Emulation on a PC? <i>Jeff Vavasour</i> | Pg. 1 |
| Run OS-9 Level One a 486 with SVGA | |
| Q&A's (<i>Printer I/O Marty Goodman, Linux Andrew Martin, Setting up Hard Drives Colin McKay, OS-9 Kernel Dave Halko</i>) | Pg. 2 |
| Writing Basic09 Code CONTEST win a book | Pg. 3 |
| How I made a Parallel Printer Adapter for my CoCo <i>by Mike Guzzi</i> | Pg. 4 |
| Sub Etha and Blackhawk join forces for the MM/1 <i>Joining Press release by Allen Huffman & David Graham</i> | Pg. 8 |
| REVIEW: <i>Bob van der Poel's Diskcat</i> <i>Catalogue you floppy disk very fast!</i> | Pg. 8 |
| Control Your Printer <i>Bob DeVries</i> Send control codes to your printer with this Basic09 program. | Pg. 9 |
| Club Activity Report Port Orchard and Seattle | Pg. 10 |

Q: I've come across an old IBM printer that has a serial connector (I think), but I can't get it to work with my CoCo when I hook it up. Could this be for parallel instead of serial?

==devin@cs.mun.ca==

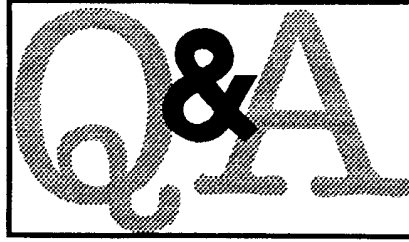

A: I am not at all familiar with the particular printer you ask about... at least, with ONLY a model number and no description, I have no idea if I've ever seen such a beast.

However, I can give you the following general advice:

(1) I've never seen a parallel printer that used a DB 25 connector for its interface. By VERY commonly followed convention, a DB 25 connector on a printer both now and in the "old days" meant a RS232 serial port and/or current loop port. So I'd be FAIRLY certain the that connector is for an RS232 port.

(2) It should be obvious how to confirm at least some aspects of this assumption: Just measure the voltage with respect to ground on some of the universally used RS232 pins (such as pins 2 and 3, especially... data in and data out). RS232 voltages will be -10 or +10 volts (plus or minus about 5 volts), where parallel port voltages, when you find them, will be between 0 and 5 volts.

If you have the pin out for a common RS232 port and a parallel port, it will take only a few seconds to confirm which of the two conventions the connector you have conforms to, if it conforms to one or the other. Only a VOM (Volt Ohm Meter) on 0 to 25 volts scale will be needed.

(3) If the printer IS serial, hooking it to a computer usually will require experience with serial interfacing, and often cannot be done without a manual for the printer. This is because you will have to set the handshake pin, handshake polarity, baud rate, and perhaps some other stuff... all of which is typically done with one of a number of DIP switches in the printer... or jumpers. If you don't have those documented, it can be hours of ones time (even if one is VERY experienced at this, as I am) to get things right. Indeed, if you don't have that information, I'd say TOSS the printer. It's not worth four hours of your time making a \$5 ancient crummy printer work!

==Marty Goodman==

MARTYGOODMAN@DELPHI.COM

Q: I've been noticing a gradual abandonment from OS-9. Why? I think OS-9 is the best thing going. I realize OSK and OS9000 are way over priced, but so are other industrial type operating systems. What could be better then OS9 for the motorola 68xxx machines?

==Chris<COCO@pucc.Princeton.edu==

A: How about LINUX? Linux also works like unix. It is Multiuser, Multitasking, requires no Multiuser license. The software base is building rapidly through both the Internet and Public Access sites (BBS'S) And, by the way, the Infomagic two disk set is only \$22.95 and this includes US Express Mail shipping.

It is not OS9 which I have enjoyed using but it is better than MESSYDOGS (MS-DOS) and/or SISSY-TEM/7.00342 (Mac's System 7). It even Beats OSSIFIED/2

(Continued on page 7)

OS-9 Newsletter

Editor: Rodger Alexander

OS-9 Newsletter is published monthly by the **Bellingham OS-9 Users Forum** and is protected under United States Copyright Laws. No material may be reproduced or copied in whole or in part without the expressed written permission of the Bellingham OS-9 Users Forum, 3404 Illinois Lane, Bellingham WA 98226

Submissions are welcomed in any format and can be mailed to the above address or sent via electronic mail to the editor, Rodger Alexander, on Delphi (UserID: SALZARD) or FidoNET (1:301/3401@fidonet.org) or Internet (ralexander@nikita.bham.wednet.edu). Unfortunately, we do not have funds to reimburse authors of selected articles. However, a complimentary copy of the *OS-9 Newsletter* containing your article will be mailed to you, PLUS the satisfaction that you will have the admiration and appreciation of all of our readers.

The *Bellingham OS-9 Users Forum* is a hobbyist club, organized for the purpose of providing information, services, products and events that support the OS-9 operating system for 6809/68xxx based computers. Our efforts are not intended to earn or generate any profit for the club or any of it's members.

TO SUBSCRIBE

For 12 monthly issues of the *OS-9 Newsletter*, please send a US check or money order for \$12 or \$7 for a 6 month subscription. Mail your subscription order to:
OS-9 Newsletter
3404 Illinois Lane
Bellingham, WA 98226

Include your name, address and telephone number. You will receive your *OS-9 Newsletter* no later than the 10th of each month. Canadian orders, \$13.50 for 1 yr. or \$7.60 for 6 mo. Foreign orders \$18 for 1 yr. or \$10 for 6 mo.

Basic09 CONTEST

Writing Basic09 Code

Here is a Basic09 code listing for the speech sound pak under OS-9. Basically, all this code does is read a file of up to 100 words, one word per line, and then prints/echos them to the speech sound pak. You must 'iniz /ssp' prior to using this code. Please feel free to modify the code to your own use.

```

PROCEDURE talk
(* Declare all variables *)
DIM count,wordcount:INTEGER
(* These are input/output variables *)
DIM spak,infile:BYTE
(* This is an array for 100 words up to 20 characters in size *)
DIM wordarray(100):STRING[20]
DIM tempword,filename:STRING[20]
(* Get the name of a file that has up to 100 words in it, one *)
(* word per line only! *)
PRINT "Please enter the name of the speech text file: ";
READ #0,filename
OPEN #infile,filename:READ
count:=1
WHILE NOT(EOF(#infile)) DO
(* Get all the words from the file (or just the first 100) *)
READ #infile,tempword
wordarray(count):=tempword
count:=count+1
ENDWHILE
wordcount:=count
CLOSE #infile
OPEN #spak,"/ssp":WRITE
(* Send the words to the speech pak for talking *)
FOR count:=1 TO wordcount-1
tempword:=wordarray(count)
PRINT #spak,tempword
NEXT count
CLOSE #spak
END

```

Here is an example of using Basic09 to send text files out to your speech sound pak. You could simply list the file to the speech sound pak. However, this is a good exercise in programming under Basic09. I hope you noticed that the code could be made more efficient.

*Take a wack at improving this Basic09 listing. Some of the improvements are obvious, while other improvements might involve creative programming techniques. Give it a shot. **The Prize** is a hard bound edition of "The Basic09 Tour Guide".*

How I made a Parallel Printer Adaptor for the CoCo

by Mike Guzzi

Several articles have been written about adding a parallel port to the CoCo's bus. The advantage is you can use virtually any printer since that port is the standard. Another option is to buy a serial to parallel converter which works very well since you don't have to worry about software incompatibility (especially under RSDOS). OS9 isn't usually a problem since most programs written will use the drivers provided in the bootfile.

Although a serial to parallel adaptor works very well, I was faced with two MINOR problems:

- 1: I have two printers, an Epson and a CGP-220, it would be great to run both.
- 2: When outputting to my printer at 9600 baud, OS9 slows to a crawl.

The serial port provided in the CoCo isn't a true serial port. Its nothing more then a PIA hooked to voltage level converters so the software has to do the timing to make sure the baud rates are correct. This means OS9 spends alot of CPU time outputting to the printer (and with IRQ's disabled!)

The solution was to build a true printer adaptor. I searched around for information and decided that the design used in the Eliminator is the best. The reason being is that it uses the data port of the PIA for the data, and the two control lines for BUSY and *STROBE. Also the eliminator software is freely available and the design of the software makes it easy to have 2 ports. The port uses a plain jane 68B21 PIA chip. The CoCo3 has one inside it (the other one used for the keyboard is similar). Ive seen designs where a PIA can be piggybacked on top of the one in the CoCo3 (*February 1993, OS-9 Newsletter*) but since I already have 1 meg it would make things messy. Plus, the PIA's inside the CoCo aren't fully decoded on the address bus. This means the addresses for the PIA ghost in several spots. My choice was to fully decode it and make it a plug in cartridge in the multipak.

The First thing that needs to be done is to choose where you plan to map the PIA. I prefer to fully decode devices since its cleaner and you don't need to mess with slot selection. Two chips usually will do the trick. On the multipak of the CoCo3 the address range of \$FF40-\$FF7F is available. The disk controller usually occupies from \$FF40 - \$FF5F (its not a fully decoded device so it ghosts in several spots) My hard disk adaptor (Ken-ton) maps itself in at \$FF76-\$FF7E. Next is to check the RS232 paks. The tandy version and all 100% compatibles map in at \$FF68 - \$FF6B if you have a second port it usually occupies \$FF6C - \$FF6F. I have a COMM-4 which is 4 serial ports and it covers from \$FF60 - \$FF6F. So basically it left me with \$FF70 - \$FF76 open. What you choose depends on the hardware you have plugged in. If you have a Burke & Burke hard disk adaptor, its SCS decodes like the disk controller.

So I chose \$FF70 - \$FF73 (the PIA needs 4 bytes) to use for the adaptor. The next thing to do is convert this to binary like this.

```
$FF70 --->  F      F      7      0
            1111   1111   0111   0000
```

Now we take them and show the address lines associated with these numbers.

```
A15 A14 A13 A12  A11 A10 A09 A08  A07 A06 A05 A04  A03 A02 A01 A00
  1   1   1   1   1   1   1   1   0   1   1   1   0   0   0   0
```

Two chips are used to fully decode the address bus. a 74LS133N and a 74LS4N. The 74LS133N is a 13 input NAND gate, the 74LS4N is a hex inverter (6 inverter gates). Ignoring A and A1 for now, everyplace you have a zero you feed it into an inverter first. The output goes into the LS133 chip. However not all address lines can fit (only 13 of them). A and A1 are used for the registers by the PIA (so the PIA can address 4 bytes) and are fed directly into the PIA. Looking at figure 1, you will see I fed A3 to A15 into the 74LS133N. Noting that A7 and A3 run through inverters first (since there is a zero in the address table). The output from the 74LS133 is fed into *CS2. (a * designates an active low pin, the pin is active when its a logic zero) CS2 stands for "Chip Select 2". This still leaves A2 hanging. No problem, I fed it to another inverter and then into CS. There is still the CS1 line from the PIA. Since we don't need it, we simply tie it to 5 volts to make it high all the time. (All chip enable lines must be active for the PIA to be active.). You will notice that *CS2 is active low so the output from the LS133 is inverted (since its a NAND gate) when the correct address of \$FF7-\$FF73 is shown on the bus. All Chip select pins are high except for *CS2 which is low and the PIA is active.

The A0 and A1 lines are fed into the RS0 and RS1 lines respectively. These are the register select lines for the PIA. Next we wire in the data bus. Simply feed the D0 - D7 lines from the CPU to the D0 - D7 lines of the PIA, Read/Write to Read/Write, *RESET to *RESET. The E Clock from the CPU is fed into the ENABLE line of the PIA. We now have the PIA connected to the bus of the CoCo.

Now we will hook the other side of the PIA to the Printer. The data lines are easy: Use the 8 data ports to represent the 8 bit characters sent to the printer. The *STROBE line is from CA1 (and CB1 if a 2nd port is used). The BUSY signal is a bit stranger, if you look at the second picture you will see the E clock from the CPU is fed into an AND gate, and the BUSY signal from the printer is also fed into the AND gate. This means whenever the printer shows a BUSY signal the output from the AND gate is zero. When the printer is not busy the resistor pulls that side of the AND gate high and the output is a 2Mhz pulse. This is fed into CA2 to be picked up as a BUSY signal to the software. You will notice a tricky thing I did on the bottom. Since I had three spare gates from the 74LS04N chip, I decided to make use of them. There is a signal to the printer to initialize it (reset it). Its an active low like the reset signal for the CPU. So the idea hit me, if I connected the *RESET line from the cpu to the printers, anytime I hit the reset button or powered up the CoCo, the printers would automatically reset as well (in case its in graphics mode or whatever), so I could simply wire them together. However, I wanted some isolation from the reset line of the CPU, so with three spare gates available I fed the *RESET line from the CPU to an inverter, split it off into two wires and fed each of them into another inverter each. This cancels the inversion and makes them a mere buffer, and provides isolation from the printers to the CPU. The capacitor shown is for deglitching purposes, to make sure there is no noise on the 5 volt line and is a good idea to have (you will notice all your RAM chips have a capacitor next to them).

Once thats all hooked up the next step is software. The drivers are in the eliminator package. You need PPIA and P from that archive. To make a second port I made a copy of P and called it P2 and re-assembled it. (You can use EZGEN is you don't have an assembler.) I bumped the port address up by 2. (The PIA has two identical ports, each using 2 bytes of memory so it makes it easy as far as os9 drivers go!) If your running NITROS-9 remember to patch the PPIA module for 6309 native mode!! Make up a new boot disk and it should work like a champ!

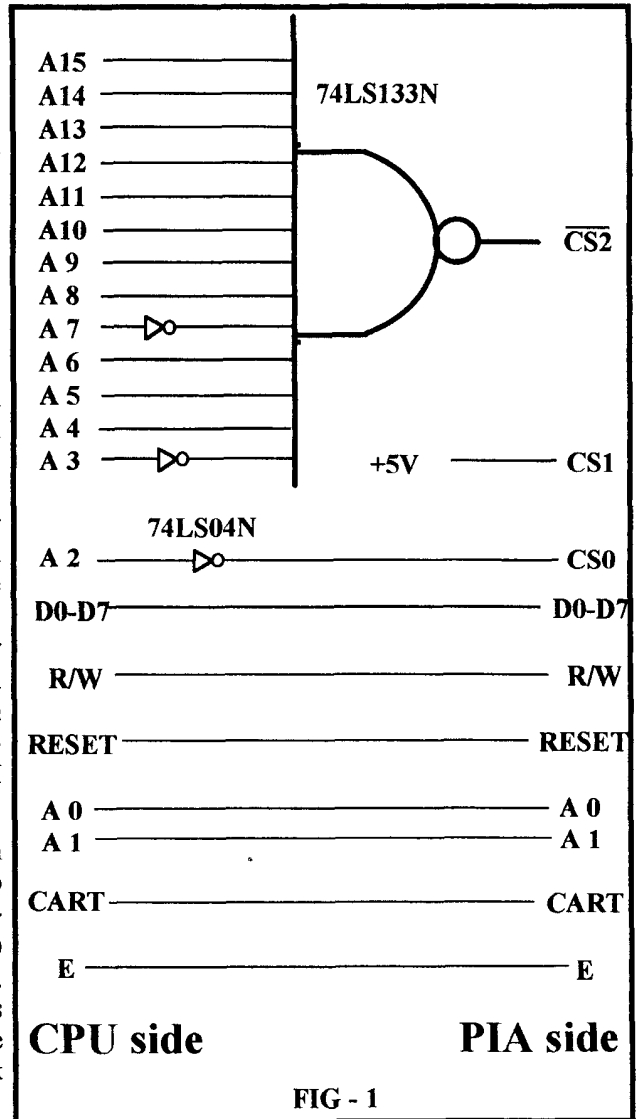

FIG - 1

These drivers are copyright by Bruce Isted, The Eliminator was sold by Frank Hogg. Thankfully they released the drivers to the public domain.

| Pinout of PIA (MC6821, MC68B21) | | | | Pinout of CoCo Cartridge port | | | |
|---------------------------------|--------|----|------|-------------------------------|--------|----|--------|
| 1 | Vss | 11 | PB1 | 21 | R/*W | 31 | D2 |
| 2 | PA0 | 12 | PB2 | 22 | CS0 | 32 | D1 |
| 3 | PA1 | 13 | PB3 | 23 | *CS2 | 33 | D0 |
| 4 | PA2 | 14 | PB4 | 24 | CS1 | 34 | *RESET |
| 5 | PA3 | 15 | PB5 | 25 | Enable | 35 | RS1 |
| 6 | PA4 | 16 | PB6 | 26 | D7 | 36 | RS0 |
| 7 | PA5 | 17 | PB7 | 27 | D6 | 37 | *IRQB |
| 8 | PA6 | 18 | CB1 | 28 | D5 | 38 | *IRQA |
| 9 | PA7 | 19 | CB2 | 29 | D4 | 39 | CA2 |
| 10 | PB0 | 20 | Vcc | 30 | D3 | 40 | CA1 |
| 1 | +12V | 11 | D1 | 21 | A2 | 31 | A12 |
| 2 | -12V | 12 | D2 | 22 | A3 | 32 | *CTS |
| 3 | *HALT | 13 | D3 | 23 | A4 | 33 | GND |
| 4 | *NMI | 14 | D4 | 24 | A5 | 34 | GND |
| 5 | *RESET | 15 | D5 | 25 | A6 | 35 | SND |
| 6 | E | 16 | D6 | 26 | A7 | 36 | *SCS |
| 7 | Q | 17 | D7 | 27 | A8 | 37 | A13 |
| 8 | *CART | 18 | R/*W | 28 | A9 | 38 | A14 |
| 9 | +5V | 19 | A0 | 29 | A10 | 39 | A15 |
| 10 | D0 | 20 | A1 | 30 | A11 | 40 | *SLENB |

NOTES:

- Pin 1 & 2 have no connection directly out of CoCo3, Voltages are present (+12 & -12) with the CoCo1 (grey cased CoCo) and Multipaks.
- DO NOT Connect the PLA's IRQ's to *NMI! The disk controller uses this and if the PIA generates an IRQ, the disk controller will get confused.
- SND is a sound input (from devices like Speech pak and Orch-90/CC).

(Continued on page 6)

I don't really plan to go into construction details. What I did was use a case from a FD-501 disk controller. I bought that IBM XT expansion board that Radio Shack sells and used a dremel to cut the board to size. I ran a ribbon cable out of the board to a DB-25 connector, from there it splits to two cables and goes to each printer. Radio Shack no longer sells the centronics solder type connector, I had to buy ribbon connectors. So you can use ribbon cable from the DB-25 to each printer cable.

Centronics Printer Connector

| | |
|-------------------|-------------|
| 1 *STROBE | 19 GND |
| 2 Data 1 | 20 GND |
| 3 Data 2 | 21 GND |
| 4 Data 3 | 22 GND |
| 5 Data 4 | 23 GND |
| 6 Data 5 | 24 GND |
| 7 Data 6 | 25 GND |
| 8 Data 7 | 26 GND |
| 9 Data 8 | 27 GND |
| 10 *ACKNLG | 28 GND |
| 11 Busy | 29 GND |
| 12 PE (paper out) | 30 GND |
| 13 SLCT | 31 *INIT |
| 14 *AUTO LF | 32 *ERROR |
| 15 NC | 33 GND |
| 16 0V (logic GND) | 34 NC |
| 17 GND | 35 +5V |
| 18 NC | 36 *SLCT IN |

*INIT is used to reset the printers.

==Mike Guzzi==
Delphi:OS-9 Sig

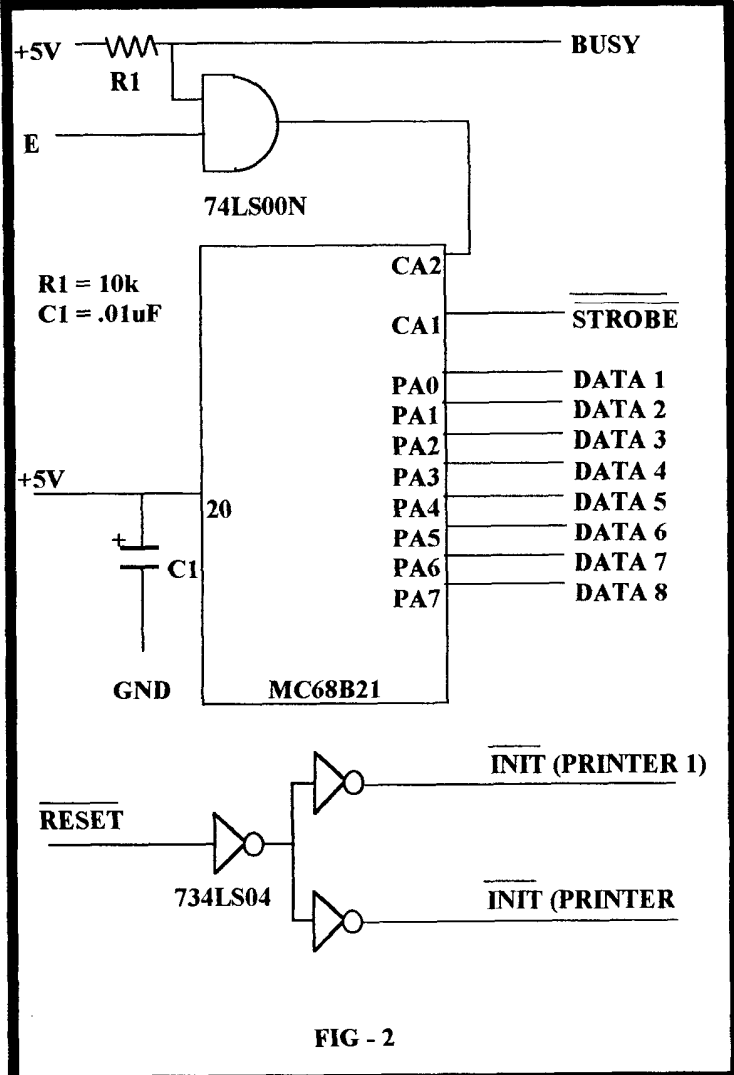

FIG - 2

Announcing

5th Annual Atlanta CoCofest

Holiday Inn, Northlake

October 1 & 2, 1994

Show Hours:

Sat. Oct1 9:00 AM - 5:00 PM
Sun. Oct2 9:00 AM - 3:00 PM

Vendor setup:

Fri. Sept 30 6:00 PM - 9:00 PM
Sat. Oct 1 8:00 AM - 3:45 AM

Admission: \$10.00 (Whole Show)

Reservations:

Holiday Inn, Northlake
(800)-464-4329 or (404)-938-1026

Sponsored by:

Atlanta Computer Society
PO Box 80694
Atlanta, GA 30366
BBS: (404)-636-2991

SMALL GRAFX Etc.



| | |
|--|---------|
| "Y" & "TRI" cables, Special 40 pin | |
| MALE/FEMALE end connectors EA. . . | \$6.50 |
| Rainbow 40 wire ribbon cable per/ft. . . | \$1.00 |
| Hitachi HD63C09E CPU & Socket. | \$13.00 |
| 512K Upgrades. | \$72.00 |
| MPI Pal upgarde. #26-3024 (chip), | |
| #26-3124 (Satellite Board). | \$10.00 |
| Serial to Parallel w/64k Buffer | |
| Interface w/cables/ps | \$50.00 |
| 2400 Baud Hayes comb. Extl. Modems | \$40.00 |

S&H EACH ORDER \$2.00

SERVICE, PARTS, & HARD TO FIND SOFTWARE, COMPLETE DOCUMENTATION AVAILABLE. INKS & REFILL KITS FOR CGP-220, CANNON & HP INKJET PRINTERS, RIBBONS, & Ver.6 EPROM FOR CGP-220 PRINTER(BOLD MODE). COLOR PRINTING.

**TERRY LARAWAY
N.W.41 DONCEE DRIVE
BREMERTON, WA 98310
206-692-5374**

(Continued from page 2)

(IBM's OS/2), and it works on what is mostly available (No it doesnt work on an 8088 or 80286 system)

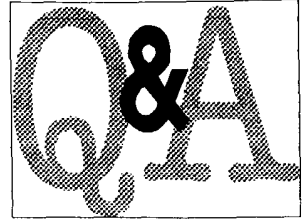

==Andrew Martin==
martin.a@fs.reid.wlu.edu

Q: I've tried everywhere to locate information on setting up a hard drive system for my color computer. I have written suppliers listed in the last few issues of *The Rainbow* but have not received any response. I know that IDE systems are cheaper to set up then SCSI. IDE hard drives are considerably cheaper, as are the controllers. Also, where can I get hard drive software....cheap!

==Jason<COCO@pucc.Princeton.edu==

A: There are no IDE based systems available for the CoCo, although Burke&Burke was working on one for a while. The B&B is an interface card that lets you plug in a PC controller (ST412/ST506). Disto works the same way, although it does not use PC cards.

One other option you might want to look into would be a KenTon interface, which is (I think) as close to a real SCSI interface as you will find for the CoCo. These are currently being sold through Farna Systems. Contact Frank Swygart (dsrtfox@delphi.com) for more information.

Bob van der Poel Software

Great Stuff for your OS-9 System

We've been in the software business for over 10 years--and we've developed lots of excellent software over that time. We don't have room in this space to tell you everthing, but we'd love to send you our catalogue listing all of our products. Great stuff like our *Ved* text editor, *Vprint* text formatter, *Cribbage*, *Magazine Index System*, *Ultra Label Maker*, *Vmail*, *Basic09 Subroutine Package*, *RMA Assembler Library*, *Stock Manager*, *OS-9 Public Domain Disk*, and more.....
All our programs are in stock for immediate shipping. So you only get what you need, please specify OS-9 or OS9/68000!

PO Box 355
Porthill, ID
US 83853

PO Box 57
Wynndel, BC
Canada VOB 2N0

Phone (604)-866-5772

In my opinion, SCSI is definitely the way to go because of availability, and for future expansion. i.e., you should be able to connect any SCSI device, and as an added bonus, the SCSI devices can still be used if you ever get a new machine.

Hard drive systems usually come with software. There are also a few after-market packages for SCSI drives that offer improved speed and reliability— SCSI47.ar (no longer officially supported), and SCISISYS, by Matt Thompson. SCISISYS is a shareware package. My business, Northern Xposure, sells the registered version.

==Colin McKay==

Q: I was wondering where I could find informaion on the OS-9 Level II kernel and so forth.

==Dr. Franklin<COCO@pucc.Princneton.edu

A: Get a hold of Kevin Darling's "Inside OS-9" book. It details the memory addresses of the OS variables, the OS calls, bugs, and fixes.

Overall, it is an excellent book and I would spend \$30 on it if I needed the info. The book is about 1/4" thick and packed full of theory and implementation details.

==Dave Halko==

Joint Press Release:**Sub-Etha Software and Blackhawk Enterprises ***

Sub-Etha Software and Blackhawk Enterprises are pleased to announce additional free software being included with all new MM/1 computer systems.

Sub-Etha's flexible CheckBook+ program will now be included with all new MM/1 computer systems. CheckBook+ is an advanced checkbook balancing program to help out with your finances. Made popular on the Color Computer, CheckBook+ can not only balance your checkbook, but also help you visualize it with many different types of graphs. Search and sort your checkbook database easily, on any field!

Joel Mathew Hegberg has written several public domain programs for the MM/1 computer system, which are available on many information services. Now, he has compiled a collection of his most popular public domain software into a new disk called "Joel Mathew Hegberg's MM/1 P.D. Anthology Diskette," which will be included with all new MM/1 computer systems. Programs which will let you: play popular MOD song files, display a graphical clock, play games, vocally announce the time, display VEF picture files, several screen savers, and much more!

Sub-Etha Software's immensely popular MiniBanners multi-line banner program will also now come standard with all new MM/1 systems. With over 30 fonts included, MiniBanners allows you to create exotic text banners on ANY printer you may own. We even include a font preview program for MiniBanners' fonts.

BlackHawk Enterprises and Sub-Etha Software are pleased to make this software available to new MM/1 owners to help them get started with their computer right away. Existing MM/1 owners who wish to obtain Joel's P.D. Anthology may obtain it through BlackHawk Enterprises for a \$12.50 media-copying-fee. Existing MM/1 owners who wish to obtain CheckBook+ or MiniBanners for K-Windows may obtain it through Sub-Etha Software for \$12.50 (\$10.00 media-copying + \$2.50 S&H). Addresses are listed below.

Sincerely,

Allen . Huffman, Sub-Etha Software
Joel Mathew Hegberg, Sub-Etha Software
David Graham, BlackHawk Enterprises

BlackHawk Enterprises
P.O. Box 10552
Enid, OK. 73706
(405) 234-2347

Sub-Etha Software
OSK/Midwest Division
936 North Twelfth Street
DeKalb, IL. 60115-2516
(815) 748-6638

Review

DISKCAT

written by Bob van der Poel

I received a disk from Bob van der Poel shortly after the PNW CoCoFEST. The disk contained C source code files for a new disk cataloging program for 6809 OS-9 and OSK. After compiling the files, two binary executable files were produced: *Diskcat* and *Rendisk*.

Diskcat is the main program that read disk and creates a database data file, *Rendisk* is used to rename disk label names since the database uses the disk name as a record name for database reference, since you can't have two records with the same name, you must use *rendisk* to rename disk with duplicate disk names.

I did come across one bug while running the program. Apparently (at least with the 6809 version) insufficient data buffer space is assigned and you get a "STACK OVERFLOW, Error #207 - Memory Full" error when attempting to start the program from the OS-9 prompt. Problem was solved by adding a memory allocation argument in the startup command:

```
diskcat #8k
```

Figure 1 shows a sample of the menu options.

```
(C) 1994, Bob van der Poel Softwareystem

<U> Update disk catalogue
<S> Search disk catalogue
<C> Change catalogue file
<L> List disk names
<O> Set output for search reports
<H> Help
<Q> Quit . . .
    >>> Choice >>>
```

Fig. 1

The Update option is used to update or add a disk to the catalog. When you select this option you are prompted to enter the "Device to archive." For testing purposes I chose to archive to the database the complete OS-9 Users Forum's Public Domain Library. This consisted of 14 3-1/2inch 720K disk. I was very impressed with the speed, each disk was scanned and recorded to the database. The largest disk was scanned and recorded in less than 25 seconds. This disk contained 73 files and 12 directories. Disk with fewer files took less time. The database recorded its data to a file called

(Continued on page 11)

Control Your Printer

It seems that Basic uses the C convention of terminating its strings with a NULL, but using PUT to send each byte individually. It works fine and here's how I did it:

```
PROCEDURE ptrctl
PARAM path:INTEGER
PARAM action:STRING
PARAM onoff:STRING
DIM number:INTEGER
DIM count:INTEGER
DIM char:BYTE
DIM found:BOOLEAN

(* PTRCTL - send printer control *)
(* character strings to printer *)
(* By Bob Devries. InterNet: *)
(*bob@splat.paxet.com.au *)
(* PUBLIC DOMAIN - 22nd July, 1994 *)
```

```
found = FALSE
IF action = "expand" THEN
    found = TRUE
    IF onoff = "on" THEN
        RESTORE 100
    ELSE
        RESTORE 110
    ENDIF
ENDIF
IF action = "underline" THEN
    found = TRUE
    IF onoff = "on" THEN
        RESTORE 120
    ELSE
        RESTORE 130
    ENDIF
ENDIF
IF action = "condensed" THEN
    found = TRUE
    IF onoff = "on" THEN
        RESTORE 140
    ELSE
        RESTORE 150
    ENDIF
ENDIF
IF action = "compressed" THEN
    found = TRUE
    IF onoff = "on" THEN
        RESTORE 160
    ELSE
        RESTORE 170
    ENDIF
ENDIF
IF action = "doublestrike" THEN
    found = TRUE
    IF onoff = "on" THEN
        RESTORE 180
    ELSE
        RESTORE 190
    ENDIF
```

```
ENDIF
IF action = "emphasized" THEN
    found = TRUE
    IF onoff = "on" THEN
        RESTORE 200
    ELSE
        RESTORE 210
    ENDIF
ENDIF
IF action = "doubleheight" THEN
    found = TRUE
    IF onoff = "on" THEN
        RESTORE 220
    ELSE
        RESTORE 230
    ENDIF
ENDIF

READ number
FOR count = 1 TO number
    READ char
    PUT #path, char
NEXT count
END

(* The first data statement is the *)
(* number of code bytes that follow *)
(* for the selected code *)

(* These codes are for a Tandy DMP202 *)
(* set up as as an IBM ProPrinterXL *)

(* modify the code below for your *)
(* own specific printer needs *)

(* "expand" "on" code *)
100 DATA 3,$1b,$57,$1
(* "expand" "off" code *)
110 DATA 3,$1b,$57,$0
(* "underline" "on" code *)
120 DATA 3,$1b,$2d,$1
(* "underline" "off" code *)
130 DATA 3,$1b,$2d,$0
(* "condensed" "on" code *)
140 DATA 1,$f
(* "condensed" "off" code *)
150 DATA 1,$12
(* "compressed" "on" code *)
160 DATA 2,$1b,$3a
(* "compressed" "off" code *)
170 DATA 1,$12
(* "doublestrike" "on" code *)
180 DATA 2,$1b,$47
(* "doublestrike" "off" code *)
190 DATA 2,$1b,$48
(* "emphasize" "on" code *)
200 DATA 2,$1b,$45
(* "emphasize" "off" code *)
210 DATA 2,$1b,$46
(* "doubleheight" "on" code *)
220 DATA 9,$1b,$5b,$40,$04,$0,$0,$0,$22,$2
(* "doubleheight" "off" code *)
230 DATA 9,$1b,$5b,$40,$04,$0,$0,$0,$11,$1
```

==Bob Devries==
Australian National OS9 Usergroup



Club Activities Report

*Bellingham OS9 Users Group - Longview/Kelso CoCo Club
Mt. Rainier CoCo Club - Port O'CoCo Club - Seattle 68xxx Mug*

Port O'CoCo

The July meeting of Port O' CoCo was more of a planning meeting than a doing meeting. It was also a review meeting. The review was of the PNW CC FEST IV held three weeks ago. Although the attendance was down a little, the event was a success. First it was a financial success. None of the reserve funds had to be used to support the costs. Also we have a couple hundred dollars tied up in inventory (a few T-shirts and several dozen mugs). When those are liquidated there will be a handsome sum for future events. We can fairly say WHEN these items are liquidated because we made a brief presentation at the Kitsap Computer Seniors at their general meeting and sold \$160 worth in a matter of minutes. At that rate it won't take long to turn these items into cash.

After the general meeting of KCS, which had just under 90 people present, the board of KCS voted to have another FEST next year, PNW CC FEST V. The probable dates are June 23rd and 24th. The location is Marcus Whitman Junior High in Port Orchard. Mark your calendars now!

We have only five of the CoCo T-shirts left. The design is the graphics of the famous three programmers who sneaked their picture into the RAM chip of the CoCo. If there ever were a collectable T-shirt, this is it! The master silk screen is already gone so these five are it. They sell for \$10 plus \$4 UPS shipping. The mugs with the puzzle on them are \$5 plus \$4 UPS shipping. The T-shirt and mug together, while the supply lasts, are \$15 plus \$4 shipping. Make all money orders or checks out to K.C.S. and mail to Donald Zimmerman, 3046 Banner Rd SE, Port Orchard WA 98366-8810.

Some of those present were not aware that Rodger Alexander is seriously discussing stopping publication of this newsletter after December of this year. There were expressions of disappointment and offers of assistance. Buzz happened to bring his complete collection of the newsletter over the years. It is impressive! The group wanted more information about the whys. Maybe this could appear as an editorial soon.

Then we discussed an article that appeared in the local paper about BBS. In the article it listed 59 BBSs available in Kitsap County. Most of them are individual hobbyists and free. A few are commercial ventures. Lists like this are probably available at local libraries for your area.

The next topic of discussion was what we are going to do in the months to come. **Buzz Jones** has assumed the role of coordinating events, speakers, topics for Port O' CoCo. He started with three great suggestions:

1. A detailed, hands-on demonstration on how to read and write to PC formatted disks on the CoCo.
2. An exploration into connecting an optical scanner to the CoCo. (An extension of that work would be to have OCR (Optical Character Recognition) software for the CoCo.)
3. For those who have a built in clock in their CoCo to be able to display the day of the week as well as the time and date.

Other topics suggested for the months to come were:

1. An in-depth discussion of what the B&B hard drive interface does and how it does it.

2. Linking a graphics or word processing program to a fax modem on the CoCo.

Finally, we discussed a project by Rick's Computer Enterprises in Liberty KY. He is attempting to amass a data base of anyone and everyone interested in the CoCo. He will mail a copy of this data on disk to anyone with two updates over the next several months for only \$12. The disk will also contain commercial information for those who are supporting the CoCo. His address is Post Office Box 276, Liberty KY 42539. We are going to mail him all the names and addresses we have to assist in his efforts. We wish him the best of success!

Our next meeting is August 15th.

==Donald Zimmerman==

Seattle 68xxxMug

Donald Zimmerman displayed COCO Fest Mugs and T-shirts left to sell (3-4 Mugs and 7 T-shirts). **Rodger** and **Donald Zongker** showed off Donald's final installation of his CoCo into a tower case. A bug still exist that causes the computer to lock up or go to extended basic (instead of disk basic). When you push the reset switch. Members in attendance proposed possible causes with the consensus that the multipak is causing the problem. Possibly a bad PAL upgrade chip.

John Schliep brought up the possibility of using a Y cable and asked Rodger to demonstrate **Bob Vander Poel's** Magazine Index to look up the Rainbow article that explained how to use a multiple Y cable as a multipak. this served as an excellent introduction to Bob Vander Poel's latest O-S 9 program:

Disk Cataloguer. Bob sent the source code and gave permission to freely distribute the compiled executable file. **Jesse Obeureiter** planned on compiling the source code for part of the meeting but was not available. Maybe next meeting.

Next session of the meeting dealt with *termcap files*. It would be nice to have the club's "PDS Database" use *termcap* files so that the screen display would be generic for any terminal running OS-9, not just the CoCo. It would be possible to edit the *EDIT* procedure using specific ESCape codes for each terminal used, i.e., VT100, Zenith, etc., but you would have to rewrite the ESCape sequences each time you changed the terminal, or have multiple versions of the *EDIT* procedure to accommodate different terminals. Jesse was also going to address the parameters for this project which would involve rewriting the *EDIT* procedure in C. This would allow the flexibility of the C Library files to link to related parameters in a *termcap* file. Since Jesse was not available, we had to postpone this part of the meeting until next month.

The meeting ended on a BIG PLUS when **Pat** announced that he had a trunk full of CoCo software, hardware and magazines to give away! One of Pat's neighbors had a house fire and needed to get rid of the CoCo stuff salvaged from the fire. We immediately adjourned the meeting and went down to Pat's car. Truly a trunk full of *Rainbow Magazines*, *Rainbow on Disk*, boxes of software, manuals, books, two CoCo-2's, a thermal printer, CoCo X-Pad, and a bag full of miscellaneous cables and electronic parts. What a reward for coming to the July meeting. Even Jesse showed up in time to take advantage of the booty.

===Barbara Alexander===

OCN NETNEWS
OS-9 COMMUNITY NETWORK
 ON-LINE MONTHLY NEWSLETTER

FIDONET OS-9 ECHO

A SUBSIDIARY OF OS-9 NEWSLETTER

(Continued from page 8)

REVIEW: *Diskcat*

diskcat.dat in a directory called */dd/DATA*.

The Search option prompts you for a search string or several search strings separated by a space. You can search on filenames or a portion of a filename or directories or a portion of a directory. The search option is also very fast. I searched the entire 12Meg *PD_Library* for any filenames with "LZH" as its name or part of its name. The search was completed in 4 seconds and listed 13 instances in less than 4 seconds. VERY FAST! Next I tried "lzh lha". In just a little more than 4 seconds I had 15 complete pathnames showing me where *lzh* or *lha* as filenames or extensions of files or part of a filename were found.

The List option is self explanatory and simply list out all of the *Continued from Page 8*

the disk names that have been scanned. For those of you who are into databases, keep in mind that the disk names are actually the record names that *Diskcat* stores the filenames under.

The Change catalogue option permits you to look or update/add records to a different data file. Remember the default data file is *diskcat.dat*. After I scanned all of the Public Domain disk, I renamed the data file to "*PD_Lib.dat*" in order to keep the PD Library separate from future *Diskcat* sessions. However anytime I want to search or update the "*PD_Lib.dat*" records, all I have to do is select "Change disk catalogue". Unfortunately, *Diskcat* does not list the data file names for you to choose from. You will have to switch to another window and do a *DIR* of the */dd/DATA* directory to see which files are available. Also, it is necessary to give the complete pathname. Since the data files are expected to be stored in the */dd/DATA* directory, I felt that requiring the complete filename was a little annoying. I hope Bob upgrades this function in future versions.

The Output option is obvious. When you

select this option you are prompted for the output device. You can specify a filename or an output device such as the printer (*/P*) or the serial port (*/T2*). The menu returns to the screen again, but this time, the output device or filename is included: *<O> Set output for search reports (/P)*. Now when you select the Search option the results will be routed to your file or output device (*/P*).

The Help options provided a very detailed text explaining each option making this program very easy to use.

I did manage to crash the program by asking it to find "ar". Since most of the older files are archived using the *AR* utility, I knew that there were probably more than 100 files with "ar" extensions. After about 15 seconds of listing more than 150 pathnames, the program locked up repeating the same pathlist over and over. I had to *Kill* the process to terminate the program. Under realistic conditions, this would never happen, so I don't consider it a "bug", just an over taxing exercise on my part.

Overall, *Diskcat* is a welcome addition to my hard drive. It is incredibly fast, compared to two other similar type utilities I have reviewed and is simple to use. This is a shareware product and is available on CIS and Delphi OS-9 SIGs under the name of *DISKCAT.LZH*. Bob van der Poel is asking a \$20 registration fee and includes a registration form text file in the archive. This is an excellent product that serious OS-9 users should have. So get it and make sure you register with Bob. My only reservation is the memory parameter that's required when calling up the program, and a personal preference to have the Change option list a directory of the */dd/data* directory.

===Rodger Alexander===



I'm done!

Washington State BBS List

COLUMBIA HTS. BBS

-- Longview/Kelso --
RiBBS (FidoNET)
(206) 425-5804

DATA WAREHOUSE BBS

-- Spokane --
RiBBS (FidoNET)
(509) 325-6787

BARBEQUED RIBBS

-- Bellingham --
PC-Board (PC-Net) - CoCo Conference #5
(206) 676-5787

PERMANENT CREW REST

-- Tacoma --
RiBBS (FidoNET)
(206) 472-6805

ULTIMATE EXPERIENCE BBS

-- Anacortes --
RiBBS (MaxNET)
(206) 299-0491

Bellingham OS-9 Users Forum

OS-9 and the Color Computer **\$7**
Tutorial and Hardware Hacker's Manual.
Includes 5-1/4 Disk of (360K) of upgrade software

Color Computer Video Library **\$10**
Fixing the MultiPak IRQ * Installing Floppy Drives
Installing 512K Memory * Installing B&B Hard Drive

OS-9 Newsletter **\$12/yr.**
12 monthly issues packed with OS9 Update, Tutorials,
Listings, Classifieds and PNW "Club Activity Reports"
Subscriber's Technical Support (206) 734-5806

Mail your order to: *Bellingham OS-9 Users Forum*
3404 Illinois Lane, Bellingham WA 98226

COPYRIGHT NOTICE

The *OS-9 Newsletter* is a copyrighted publication by the Bellingham OS-9 Users Forum; Rodger Alexander, Editor. Duplication and/or distribution is prohibited without written permission of the editor.

OS-9 Newsletter
3404 Illinois Lane
Bellingham, WA 98226-4238