

DRAGON USER

International edition

The independent Dragon magazine

75p US\$3.25

March 1985

**Flight
Simulators
take to
the air**

**Sequential
Files**

Handling Interrupts

**Adventure
Trail**

**Can you solve
Mastermind?**

**WIN 15 copies of
Worlds of Flight
From Microdeal**



DRAGON USER



Telephone number
(All departments)
01-437 4343

Editor
BRENDON GORE

Production Editor
BARBORA HAJEK

Software Editor
GRAHAM TAYLOR

Editorial Secretary
GERALDINE SMYTH

Group Advertisement Manager
DAVID LAKE

Advertisement Manager
SIMON LANGSTON

Administration
THERESA LACY

Managing Editor
DUNCAN SCOT

Publishing Director
JENNY IRELAND

Subscriptions

UK £10 for 12 issues
Overseas (surface) £16 for 12 issues

ISSN 0265-0177. Telex: 296275

Dragon User, 12/13 Little Newport Street,
London WC2H 7PP

US address: c/o Business Press
International, 205 East 42nd St, New York,
NY 10017

ABC

Published by Sunshine Books, Scot Press
Ltd. © Sunshine Books 1985

Typesetting by Chesham Press, Chesham,
Bucks. Printed by Eden Fisher (Southend)
Ltd, Southend-on-Sea, Essex

Distributed by S.M. Distribution, London
SW9. 01-274 8611. Telex: 261643

Registered at the Post Office as a news-
paper

Dragon and its logo are trademarks of
Dragon Data Ltd

How to submit articles

The quality of the material we can publish in
Dragon User each month will, to a very great
extent depend on the quality of the
discoveries that you can make with your
Dragon. The Dragon computer was launched
on to the market with a powerful version of
Basic, but with very poor documentation.

Articles which are submitted to *Dragon
User* for publication should not be more than
3000 words long. All submissions should be
typed. Please leave wide margins and a
double space between each line. Programs
should, whenever possible, be computer
printed on plain white paper and be accom-
panied by a tape of the program.

We cannot guarantee to return every
submitted article or program, so please keep
a copy. If you want to have your program
returned you must include a stamped,
addressed envelope.

Contents



Letters	5	Sequential files	22
Manic Miner query, a change of mode, back issues and an Edit command tip		Robin Hamilton explains how to create a 200K database on tape using sequential file techniques	
News	7	Interrupt printing	26
The latest information on new software for the Dragon plus news of a bulletin board service for Dragon 64 owners		John Nash reveals some of the mysteries of the interrupt routine and how it can be used for printing	
Flight Simulators	10	Open File	28
Brian Cadge compares two flight simula- tors and discovers that landing is more difficult than taking off		Readers' programs this month include . . .	
Dragonsoft	11	Adventure trail	35
John Scriven takes a look at some of the latest games on offer, including Speed Racer and Draconian from Microdeal		Mike Gerrard provides hints and tips on a range of adventures including an incredi- ble shrinking scientist	
Expansion system	13	Bookbytes	37
Hywel Francis examines Race Electronics new expansion system		Arcade games and introductions to com- puters for novices feature among this month's selection	
Mastermind	14	Dragon Answers	39
Xavier Devreker presents a computerised version of the popular board game — our program of the month		Another batch of timely advice from Brian Cadge, plus a routine to unplug the DOS cartridge using software	
Doodling	18	Competition corner	42
John Smith presents a simple turtle graphics type program for drawing on the Dragon's hi-res screen		Win 15 copies of Worlds of Flight from Microdeal in this month's competition from Gordon Lee (Front cover by Mike Berend)	

Editorial

When the Dragon was first launched, one of the most common queries was nothing to do with the operating system or machine code, it had to do with the whereabouts of the mushroom in Madness and the Minotaur.

Some of the earliest independent Dragon software houses were also heavily adventure biased, notably Salamander Software, creator of the inscrutable Dan Diamond.

FOR SOME REASON there is a remarkable affinity between Dragon owners and adventure games. Many of the recent game releases have been adventure orientated. Incentive has recently converted its Ket Trilogy to the Dragon, while both Adventure International and Channel 8 have also released adventures. Now Compusense has launched a version of the classic Colossal Cave.

This is not to say that Dragon owners are not interested in arcade games or more serious applications. There are as many standard shoot 'em up games for the Dragon as there are for most micros. Manic Miner, Grid Runner and Lazer Zone have all been converted to the Dragon.

However, the adventure market still seems to have an irresistible attraction for Dragon owners. Wintersoft's Ring of Darkness and Return of the Ring have built up a dedicated band of followers, as has Dragon Data's El Diablero.

Given the depressed state of the Dragon market generally, it is nice to know that there are some areas which are still relatively buoyant. Happy adventuring!

OASIS SOFTWARE

present . . . TWO NEW RELEASES



SPRINT BASIC COMPILER

A rapid step forward in Home Programming.

The newly released 1.1 upgraded compiler written by Dr. David Gray for Dragon 32 and 64 owners. By converting your own BASIC programs into intermediate code, Sprint accelerates them by up to 5 or even 10 times their normal running speed. Supporting virtually all the integer BASIC and cassette and printer commands. Sprint programs are not only compiled from tape but also run independently of the compiler.

DRAGON 32 & 64 DRAGON CHESS

- Six levels of play.
- All legal chess moves including en-passant, castling and pawn to queen promotion.
- List of previous moves stored which can be deployed or printed.

- Loading and saving of games positions from tape.
- High resolution graphics which can be flipped round to make black or white play from either end.
- Simultaneous text and graphics.

- Sides can be exchanged at any stage.
- Best move hint.
- Set up from any position.
- Opening move library.
- Moves may be taken back and play resumed from any point.
- "I thought this was an excellent version of the game. Well worth buying." (Home Computer Weekly)
- Change level of play at any point in the game.
- Will adjust to games between humans.
- Very high standard of play.
- Professional packaging and lifetime guarantee.
- "Dragonchess is without doubt the best value chess on the market today." (Microdeal)



MIND GAMES COMPENDIUM.

All five games for just **£19.95**

Oasis Products are available from  and all good software suppliers. Including: Websters, Games & Computers, Microdeal, The Dragon Dungeon, PCS Distribution, Pilonmist, Goal Computers (France), Falck Computers (Scandinavia) and Joylab (Germany).

If your local dealer does not stock these products then let us know his address and we will contact him.



Access orders taken by phone 24 hours a day.

0934 419921

Every product carries a lifetime guarantee. All prices include VAT and p & p.

BACKGAMMON

The well known game of backgammon complete with full instructions and computer demonstration for beginners.

REVERSI

At last! Reversi running on your Dragon 32 or 64. 2 levels of play, full instructions and computer demonstration for beginners.

INVADER CUBE

As well as being one of the best games of skill written for the Dragon 32 and 64 it also has some of the best pure machine code graphics we have ever seen.

DOMINOES

Two games in one with full instructions. Hours of frustrating fun this program has 6 levels of play and on the higher levels adopts its play to its assessment of your ability.

PETITE PASCAL

Not just a language - an education in structured programming.

This extended integer subset of the structured programming language is the ideal introduction, not only to a language widely used in schools and universities but also to programming itself. As an appreciation of PASCAL is generally accepted as the best way to increase your understanding of structured languages, this is a must for anyone who takes computing seriously.

OASIS SOFTWARE
Oasis Software, 9a Alexandra Parade,
Weston-super-Mare, Tel. 0934 419921

Please send me
SPRINT BASIC COMPILER
PETITE PASCAL

£14.95
£14.95

I enclose cheque/PO for £ _____

Name _____

Address _____

OASIS SOFTWARE

OASIS SOFTWARE

Oasis Software, 9a Alexandra Parade,
Weston-super-Mare, Tel. 0934 419921

Please send me

DRAGON CHESS

Dragon 32 £9.95

BACKGAMMON

Dragon 64 £5.95

REVERSI

Dragon 32 £5.95

DOMINOES

Dragon 64 £5.95

INVADER CUBE

Dragon 32 £5.95

MIND GAMES COMPENDIUM

Dragon 64 £19.95

NAME _____

ADDRESS _____

I enclose cheque/PO for £ _____

Letters

This is the chance to air your views — send your tips, compliments and complaints to Letters Page, *Dragon User*, 12-13 Little Newport Street, London WC2H 7PP.

Load, store and retrieve

HAVING STRUGGLED long and hard with Dragondos random access data files perhaps readers would be interested in the two accompanying programs that, when run, load, store and retrieve an array up

to three dimensions in a For/Next loop.

A Stein
48 Suffolk Road
Seven Kings
Ilford
Essex

```

10 'TWO PROGRAMES TO LOAD, STORE, & RETRIEVE ARRAYS
20 'NO DIMENSION CAN BE LARGER THAN 10
30 '% THERE CANNOT BE MORE THAN 3 DIMENSIONS
40 'IF THEY WERE THE STORE PROGRAM WOULD ACCEPT
50 'THEM BUT THE RETRIEVE PROGRAM WOULD NOT
60 'STORE PROGRAM
70 CLS
80 DIM X(4,5,6) 'FOR EXAMPLE
90 CREATE"DATAFILE",130 'Eie 4*5*6+10BYTES
100 FOR A=1 TO 4
110 FOR B=1 TO 5
120 FOR C=1 TO 6
130 INPUT X(A,B,C) 'TO LOAD WITH A FOR/NEXT LOOP
140 BL=10:BP=BL+BP:CBL=BYTE LENGTH-BP=BYTE POSITION
150 FWRITE"DATAFILE",FROM BP,FOR BL:X(A,B,C)
160 NEXT C
170 NEXT B
180 NEXT A

```

```

10 'PROGRAM TO RETRIEVE DATAFILE
20 CLS
30 PRINT
40 INPUT"A NAME":A
50 INPUT"B NAME":B
60 INPUT"C NAME":C
70 BP=((A-1)*30)+((B-1)*6)+C)*10
80 'EXPLANATION OF VARIABLE BP ABOVE
90 'ALL THE DIMs EXCEPT THE ONE ON EXTREME RIGHT
100 'ARE ALWAYS -1
110 'THE MULTIPLES STARTING AT THE LEFT ARE ALWAYS
120 'THE DIMS ON THE RIGHT MUTIPLIED TOGETHER, Ie
130 'IN THIS CASE A=5*6 & B=6 AS ONLY 1 DIM REMAINS
140 'TWO DIM ARRAYS ARE DONE THE SAME WAY
150 '% AN EXAMPLE OF X(B,C)=X(5,6) WOULD BE
160 'BP=((B-1)*6)+C)*10
170 'ONE DIM ARRAYS WOULD SIMPLY HAVE BP=SIZE
180 'OF ARRAY, Ie X(C) WOULD SIMPLY BE BP=C*10
190 FREAD"DATAFILE",FROM BP,FOR 10:X(A,B,C)
200 PRINT"ANSWER":X(A,B,C)
210 GOTO 30

```

screen-dump program in the September 1984 issue works perfectly on the Mannesmann Tally "SPIRIT-80" printer too, and has proved very useful to me!

John Harrington
8 West View
Northgate
Morpeth
Northumberland NE61 3BT

Back issues on demand

DURING THE past month I have been abroad and, as a consequence, missed the December issue of *Dragon User*. My local newsagent has already sent back his unsold copies. Is there any way I could purchase this issue, either from the publishers or some 'back issue' company?

G White
202 Cutenhoe Road
Luton
Beds LU1 3NJ

Back issues of the magazine are available direct from us. Simply send £1.25 per copy to *Dragon User*, Back Issues, 12-13 Little Newport Street, London WC2H 7PP.

Simple solution

WITH REFERENCE to R Hadekel's letter in *Dragon User* September there is a simple solution to his problem. This is to use the PCLEAR subroutine located in ROM, avoiding the check for PCLEAR 0.

If the following line is added to the beginning of a program, it will cause the removal of all high-res pages with the loss of variables, but not the program

(ie as with the normal PCLEAR). But, beware, high-res commands are not disabled and, if they are used, the basic program will very likely be corrupted:

```
A$=CHR$(&H96)+CHR$(&HBC)+CHR$(&HC6)+CHR$(&H01)+CHR$(&H1F)+CHR$(&H02)+CHR$(&H7E)+CHR$(&HAA)+CHR$(&H35):A=VARPTR(A):A=PEEK(A+2)*256+PEEK(A+3):EXEC A
```

F Carlotti
Hope Point House
Kingsdown
Deal
Kent

Mystery functions

DRAGON DATA is not the only culprit in failing to provide complete documentation in computer software manuals. Other users of 6809 based machines and Microsoft Basic seem to find omissions and errors on a regular basis. I'd like to pass on a recent "find" by Alan Farmer, as reported in the Reader's Forum of the September 1984 issue of *Hot CoCo*. The "Mystery Functions in the EDIT Command" that he found in his TRS-80 colour computer work perfectly well in the Dragon.

Three single key functions are described: A, Q, and E, used while the computer is in edit mode. A is particularly helpful to hackers like myself who manage to mess up the corrections while in EDIT, and then wish that they could erase the "corrections" and start over without leaving EDIT. A single stroke on the A key does just that.

Q is for the person who realises that he is editing the wrong line, or that the original was really correct. Q not only erases the editing, but also exits the EDIT mode.

E allows you to exit the EDIT mode immediately without displaying the balance of the edited line. A minor time-saver. One important item that wasn't mentioned, if you are in Insert mode within EDIT, then the letters A, Q, and E are simply inserted into the program line you are editing.

Harry C Taylor II
Kiriati-Ono
Israel

Infinite lives poke?

I HAVE recently purchased a game called *Manic Miner*. Is it possible to obtain a code to enable me to have as many lives and screens as possible, as one can on the Commodore 64 and Spectrum?

Robert Williams
12 Esplen Avenue
Crosby
Liverpool L23 2SS

might be able to get out of the lower-case text mode by using a poke from within the program, rather than the "SHIFT+@" from the keyboard. Can you tell me whether this is possible and how I might do it?

By the way, you may be interested to know that lololap Gwynn's machine code

A change of mode

I AM putting together a very simple program on the Dragon 32 which will enable me to produce letters, reports and such like via a printer.

One problem I have at the moment is figuring out how I

Software Top 10

- | | | | |
|----|------|--------------------------|-------------------|
| 1 | (5) | Manic Miner | Software Projects |
| 2 | (-) | Mystery of the Java Star | Shards |
| 3 | (1) | Hunchback | Ocean |
| 4 | (3) | Dragon Chess | Oasis |
| 5 | (2) | Chuckie Egg | A & F |
| 6 | (7) | Sprite Magic | Knight Software |
| 7 | (10) | Bug Diver | Mastertronic |
| 8 | (-) | Cuthbert goes Walkabout | Microdeal |
| 9 | (-) | Ring of Darkness | Wintersoft |
| 10 | (-) | Database | MST |

Chart compiled by Websters Software

NEW
FROM
MICRODEAL
DRAGON 32/64 &
TANDY COLOUR
32K



Atari & Commodore 64 owners, eat your hearts... this has got to be the best Grand Prix game ever. Fast action, super smooth scrolling "crisp" graphics, and loads of extras, such as... 4 circuits to choose from, a tyre change if they burn their tyres out too quickly, plus a set number of cars to pass in order to qualify. Its fast and very very good.

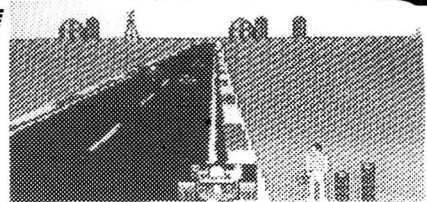

MILES 1.07
CARS PASSED
SCORE 8100

1 Joystick required **TANDY COLOUR VERSIONS ONLY AVAILABLE FROM TANDY STORES**

Post & Packing 50p

Tape £8.00

NEW
FROM
MICRODEAL
DRAGON 32/64 &
TANDY COLOUR
16K

ATHLETYX

Here's the one everybody with a Dragon or Tandy has been waiting for. A track and field game for 1 or 2 athletes with great graphics and 6 arm wrenching incredibly tiring events.

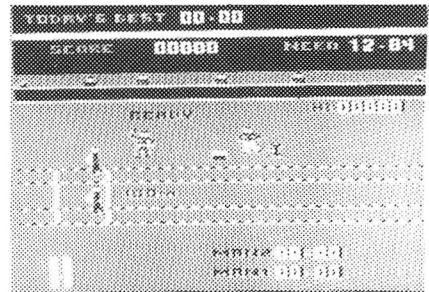

1 Joystick required

TANDY COLOUR VERSIONS ONLY AVAILABLE FROM TANDY STORES

Post & Packing 50p

Tape £8.00

NEW
FROM
MICRODEAL
DRAGON 32/64 &
TANDY COLOUR
16K

Cuthbert in the Cooler

Cuthbert's been zapped back in time to World War II, and whats worse, into a prisoner of war camp. So our elusive hero has to escape. Firstly - he must try and grab the keys from the drunken guards, and make a dash for the main doors - then he must find some "papers" and leg it through the mine field, then the ferry and... much much more. 100% machine code... Hi Res Graphics 1 Joystick required

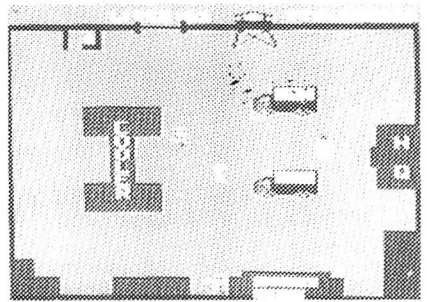

TANDY COLOUR VERSIONS ONLY AVAILABLE FROM TANDY STORES

Post & Packing 50p

Excellent value £8.00

NEW
FROM
SPECTRAL INC.
DRAGON 32 &
TANDY COLOUR
32K

ICE CASTLES

A truly superb three-dimensional graphics type arcade adventure where you must save the crystals from the marauding minotaurs. An original concept in graphics where you can travel through the tunnels and use the lifts between floors. Complete with wicked witches and magic trees. 100% machine code... Superb graphics... joystick required.

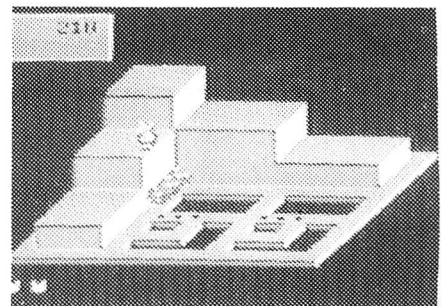

VERSIONS ONLY AVAILABLE FROM TANDY STORES

Post & Packing 50p

tape £8.00

NEW
FROM
MICRODEAL
DRAGON 32

Tele Artist

Completely Menu controlled Audible Alert if wrong information entered Draw Strings automatically recorded for quick reference Change PMODES at the touch of a key Simple cursor movement by means of arrow keys full UPPER & LOWER CASE Large and small Rubber User Define keys plus SIX OTHER USEFUL FUNCTIONS

tape £4.95

Post & Packing 50p

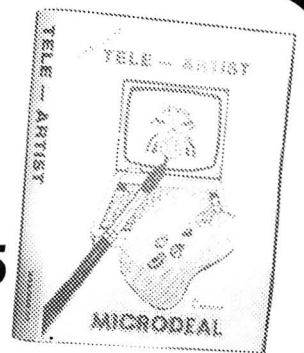

TO ORDER



or post to

0726 73456

MICROMAIL

41 TRURO ROAD, ST. AUSTELL
CORNWALL PL25 5JE



8 LINES · 24 HOURS

P&P 50p per order

Revenge

ROMMEL'S REVENGE is a new game from Design Design for both Dragon and Tandy owners. Originally written for the Spectrum, *Rommel's Revenge* is a version of the *Battlezone* arcade game.

The game, which costs £7.95, features 3D graphics with full perspective.

The object of the game, which is set on a futuristic battlefield, is to destroy the enemy tanks ploughing relentlessly towards you. The enemy tanks are remote controlled and come in two types, standard and super deadly. Both types are controlled by mobile fire control saucers which hover low over the battlefield.

You can avoid enemy shells by using the blocks and pyramids scattered around the battlefield as cover. But, your only defence against an air-launched anti-tank missile is

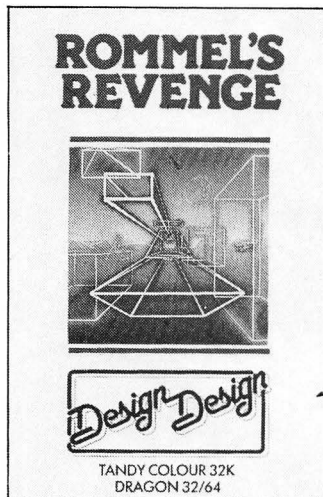

to destroy it before it destroys you.

The game, which is joystick compatible, is available from Tandy dealers or direct from Design Design, 2 Ashton Way, East Herrington, Sunderland SR3 3RX.

Bulletin Board

BRIAN LLOYD, author of Sunshine's *Dragon Trainer*, is setting up a bulletin board for Dragon owners. It will run on a Dragon 64 with twin disk drives, once British Telecom has installed another telephone line.

Dragon owners wishing to access the bulletin board will need a 300/300 baud modem and an RS232 interface.

Anyone who wishes to contribute to the bulletin board, or who has ideas about the kind of services it could offer, is invited to contact Brian Lloyd at 9 Hornbeam Walk, Witham, Essex.

German network

A GERMAN Dragon club is looking to expand its contacts with Dragon owners in other countries. Interested parties should contact Rainer Hillig, Thorkoppel 17b, 2000 Barsbuettel, West Germany.

Graphic design displays

ORON SOFTWARE has launched a graphic design pad for designing hi-res screen displays. The pad consists of 100 sheets of A4 paper marked out in a 256 x 192 screen. It costs £2.90, or £5.50 for two, from 64 Prince Street, Rochdale, Lancashire.

Colossal adventure

COMPUSENSE HAS written a version of the classic Colossal Cave adventure for the Dragon 64. The adventure is text based and only available on disk.

There is no load or save feature, due to the lack of space. The game, which should be on display at the 6809 show, costs £9.95 from Compusense, PO Box 169, 286D Green Lanes, London N13 5TN.

Modems, networks and languages

THAMES TELEVISION has launched a weekly eight-part television series for serious computer users. The series, which started on Channel 4 on February 11 at 5.30 pm, will look at modems, networks and languages such as Logo and Prolog.

In addition, the series "4 Computer Buffs", will launch a new Prestel service for

schools, Schoolink. Other features will include news, gossip and data transmissions of software over the air. DIY enthusiasts will learn how to construct a light pen.

Finally, the series will be running an interactive bulletin board through Nottingham Building Society's Homelink mainframe.

New releases

LEICESTER BASED Blaby Computer Games has released three new games in its Dragon Gold Range. *Olympia!* is a sports simulation which consists of five different events in which you have to compete against the clock. *Cosmic Crusader!*, with 34 screens of action, is an interplanetary shoot'em up, while *Ruby Robba!* is a strategy game where you must steal a precious stone protected by snakes, guards and mines. All three games cost £3.99.

Blaby, which now has 17 titles to its credit, is converting its games to the Tandy Colour Computer. *Ruby Robba! Boris the Bold and Bells* are already available for the Tandy, also



COSMIC CRUSADER



DRAGON 32

priced at £3.99.

In addition, Blaby hopes to show another three new games for the Dragon at the 6809 show in March.

Power-up

TOUCHMASTER has increased the price of its power pack for the Dragon. The new cost of the pack is £9.95 plus £1.50 P&P and not £7.50 as reported in *Dragon User* last month.

The company also announced that it is unable to help with Dragon hardware problems. The Dragon-only telephone line has been disconnected and all inquiries to the company should be made on 0656 744770.

The Demon

COTSWOLD Computers are to write Dragon software for the Unicom modem. The modem which is being renamed the Demon, retails for £49.95 (see *Dragon User*, December

1984) and is produced by the Rushworth Dales group — the organisers of the 6809 show.

It is expected that Cotswold will be exhibiting the modem and software at the show which is being held at the Royal Horticultural Halls in London, from March 30-31. Further details from Rushworth Dales on 01-930 1612.

Scramble

THE SCRAMBLE program in the February edition of *Dragon User* contained two errors. Line 1490 was misprinted. The correct data listing is:

```
DATA 0, 8, 33, 128, 0,0,0,0,0, 189, 248,0
```

Secondly, half of line 1990 was not printed. The complete line should read:

```
1990 IF (PEEK (65280) AND 1)=0 AND S <4 THEN GOSUB 2110
```



DRAGON SOFTWARE

Special Offers

Petigrew's Diary
A three-part family adventure game.
Empire
A colourful world strategy game.

New In

Rommel's Revenge
You are at the controls of an advanced battle tank.
Manic Miner
This hugely successful game involving Miner Willy.
Hunchback
Quasimodo must rescue the imprisoned Esmeralda from the castle stronghold.

Extras

Joysticks
These popular joysticks represent excellent value for money.
Dust Cover
A top quality cover in black with red logo.
Carrying Case
Superb British-made case manufactured from heavy duty vinyl. Also carries transformer and leads.

Educational

Number Chaser
Age range 7 - 10 years.
An enjoyable program designed to further number estimation skills.
Shape Up
Age range 3 - 6 years.
A program to aid shape recognition.

Adventure Corner

Shenanigans
Hi-res graphic adventure - discover the pot of gold at the end of the rainbow.
Sea Quest
Under-water graphic adventure in hi-res.
Dragon Data's Classic Text Adventures
Calixto Island
Black Sanctum
Final Countdown
Mansion of Doom
Stalag/Eno



Plus much, much more . . . send for our full catalogue TODAY!

<input type="checkbox"/>	JOYSTICKS (PAIR)	T9000	£7.95
<input type="checkbox"/>	DUST COVER	T9001	£4.95
<input type="checkbox"/>	CARRYING CASE	FAC133	£14.95
<input type="checkbox"/>	SHAPE UP	L30847	£5.49
<input type="checkbox"/>	NUMBER CHASER	L30849	£5.49
<input type="checkbox"/>	SHENANIGANS	M30943	£5.49
<input type="checkbox"/>	SEA QUEST	M30944	£5.49
<input type="checkbox"/>	BLACK SANCTUM	N30509	£2.49
<input type="checkbox"/>	CALIXTO ISLAND	M30508	£2.49
<input type="checkbox"/>	MANSION OF DOOM	M30524	£1.99
<input type="checkbox"/>	FINAL COUNTDOWN	M30523	£1.99
<input type="checkbox"/>	STALAG/ENO	M30526	£1.99
<input type="checkbox"/>	ROMMEL'S REVENGE	T9123	£7.95
<input type="checkbox"/>	HUNCHBACK	T9124	£6.90
<input type="checkbox"/>	MANIC MINER	T9119	£7.95
<input type="checkbox"/>	PETTIGREW'S DIARY	T9139	£1.99
<input type="checkbox"/>	EMPIRE	T9141	£1.99

Please Tick
POST AND PACKING (UK ONLY) £ 1:50 p
TOTAL ENCLOSED £ : p

METHOD OF PAYMENT.
BY CHEQUE OR POSTAL ORDER MADE PAYABLE TO TOUCHMASTER LTD.

OR CREDIT CARD VISA/ACCESS/AMEX/DINERS

ENTER CARD No.

SIGNATURE

ALL TITLES SUBJECT TO AVAILABILITY.
WE WILL ENDEAVOUR TO DESPATCH WITHIN 48 HOURS OF RECEIPT OF ORDER.

OVERSEAS P&P £5.00

TOUCHMASTER LTD
P.O. BOX 45
MARGAM
PORT TALBOT
WEST GLAM
SA13 1WD

TELEPHONE ORDERS 0656 744770

NAME _____

ADDRESS _____

POSTCODE _____



NOW AVAILABLE — New De-Luxe Light Pen for The Dragon — £17.25

TOP VALUE LIGHT PEN

DRAGON 32/TANDY COLOUR 32K/SPECTRUM 48K

THE NEW ADVANCED PROGRAM
for the Trojan light pens include the following facilities-

- * DRAW BOX
- * DRAW CIRCLE
- * DRAW LINE
- * DRAW PICTURES FREEHAND
- * COLOUR FILL DESIGNATED AREAS
- * SAVE AND LOAD PICTURES TO AND FROM TAPE
- * FULL ERASE FACILITIES

All in Hi-Res screen in any of 4 colours for the Dragon/Tandy, and 8 colours for the Spectrum.

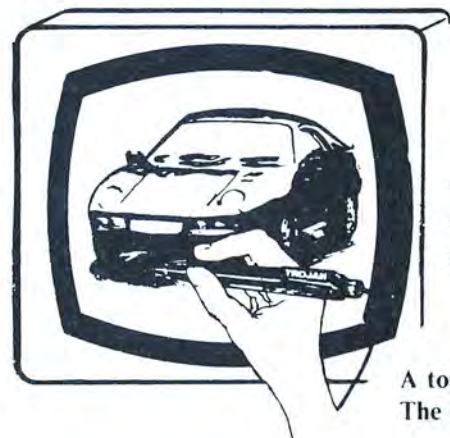

- * DATA ENTRY AND PROCESSING
- * MENU SELECTION AND CONTROL
- * GAMES PLAYING

This is a first class program which gives hints and tips on how to write programs for the pen. Ideal for many educational uses.

A top quality pen plus a first-class program. The best value pen package available.

Send cheques/P.O. to:
TROJAN PRODUCTS
166 Derlwyn, Dunvant, Swansea SA2 7PF
Tel: (0792) 205491

TROJAN





Micro Computer Software & Accessories

ALSO AVAILABLE FROM GOOD COMPUTER DEALERS

blaby computer games

DRAGON 32 and TANDY COLOR

COSMIC CRUSADER — Venture where no man has dared to go before. View the galaxy from within the safety of your starship, but not for long — no less than 34 screens of interplanetary alien life will challenge your reflexes and fire power. Superb sounds and graphics. JS/KB. **£3.99**

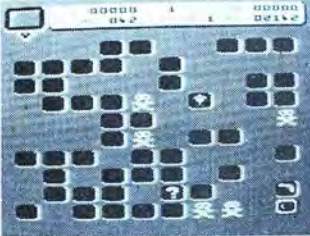

*** RUBY ROBBA** — There is a complex defence system guarding the precious ruby. Snakes, guards and mines. You have only one minute to carry out the operation but you can do it. I know you can. **£3.99**



OLYMPIA — Compete in five athletic events — 100 metres, discus, long jump, hurdles and high jump. Features include: high graphics sound, world records and hall of fame. KB. **£3.99**



MORBID MANSION — Ten rooms in this old mansion must be negotiated before you come face to face with the dreaded Morbid. You are alone then suddenly the clock gets to 12! 10 screens arcade adventure. JS. **£3.99**



MUTANT WARS — Fifteen screens of constant zapping for all you arcade freaks. Spinning wheels, rotating robots, spaggy birds and the dreaded Yum Yum monsters. Superb Hi-Res graphics. **£1.99**



*** THE BELLS** — You have probably read the novel or seen the film — now you can play the game. Rescue Esmeralda from the bell tower. 14 screens of danger for you to challenge. JS/KB. **£1.99**



BARMY BURGERS. Baps, Burgers, Cheese and Lettuce. They are all there all you have to do is put them together — sounds easy doesn't it — but not when you are being chased by a fried egg and sausages. JS. **£1.99**



*** BORIS THE BOLD** — Urgent telegram for Boris. Stop. Please come home. Stop. Beware of the patrollers, lasers and bombs. Stop. Please grab a few diamonds on your way. Stop. JS. **£1.99**

*These games are available for the Tandy Color 32 Computer at £3.99 each.

ORDER NOW DIRECT FROM THIS COMPANY OR ASK AT YOUR LOCAL DRAGON STOCKIST. PLEASE ADD 50p POST AND PACKING PER GAME. SEND S.A.E. FOR FULL LIST OF SCREEN SHOTS. WE NOW HAVE 17 TITLES.

BLABY COMPUTER GAMES
CROSSWAYS HOUSE
LUTTERWORTH ROAD, BLABY, LEICESTER
TELEPHONE: 0533-773641. TELEX: 342829 DYNA-G





WE NEED YOUR GAME! SEND NOW

FLIGHT SIMULATORS have come a long way since the early instrument orientated "games". The latest programs include real time 3D graphics and accurately mimic the responses of a plane in flight.

Microdeal has just released *Worlds of Flight* for the Dragon, which comes in an impressive over-sized video style box with a full size flight manual. The simulation is "view" orientated — you see the view out of the window in real time 3D graphics, which move as the plane taxis or flies. The program takes its title from the fact that there are nine worlds which you can fly around in. These "worlds" are in effect just different landscapes, including mountains, cities, islands and gulfs. There is also a useful practice world which is completely empty, apart from the airport.

Getting real-time 3D graphics on the Dragon may sound like a minor miracle, but there have been a number of trade-offs to achieve this. All the graphics are shown as wire frame drawings, rather than solid objects. The technique used is to define each world as a series of points on a three dimensional model. These points are then transformed into the aircraft's frame of reference and projected on to the screen.

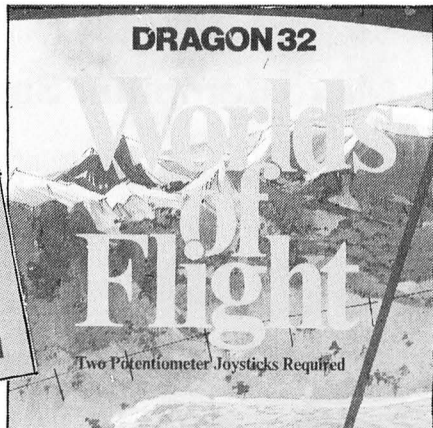

The resulting points are then joined up by lines. This method is a very memory efficient technique and works quite well. However, some users might find it hard to visualise the 3D effect with just wire frames.

Worlds of Flight is written entirely in machine code and requires two potentiometer joysticks. Please note that some switch type joysticks that are now available for the Dragon cannot be used as the simulator needs to sense the position of the sticks.

After a fancy title page showing your plane, which is apparently an experimental sport trainer, doing an aileron roll, you are presented with the "Define Worlds" section. This allows you to define which world out of the nine you want to fly in. It is also possible to change the wind speed and direction, as well as setting the "Ceiling" below which the ground and other landmarks are visible. Pressing the Enter key starts the simulation.

The upper half of the display (Pmode 4) shows the view out of the aircraft's window, the lower half shows all the instruments. The airport view is always the same in every world, with the runway,

In Flight

Brian Cadge takes to the skies in this review of two flight simulators

control tower, fuel stations and fire station. Using the keyboard, it is possible to pan around (the equivalent of moving your head) left to right, or up and down, this is controlled by the arrow keys. Another useful viewing option is the Radar, which gives a bird's eye view of the current world, with a cross marking the plane's position. You can even zoom in on the radar.

The instrument panel shows all the essential flight information, such as a fuel gauge, speed, engine speed, artificial horizon (shows which way up you are), altimeter, compass, rate of climb, brake indicator and landing gear indicator.

The up/down movement of the left joystick controls the throttle, and the left/right movement controls the rudder. The up/down movement of the right joystick con-

trols the elevator (ie makes the nose go up or down) and the left/right movement controls the roll rate.

Pressing both joystick buttons at once starts the engine, and once the brakes are released the aircraft begins to taxi along the runway. Following the suggested procedure for taking off in the manual, it is quite simple to become airborne. However, I found it a lot harder to land successfully!

It is apparently possible to do a number of aerobatics in the air, but plenty of practice is needed first. Once you've mastered simple flight, you can land and refuel at any airfield and continue the flight through the various worlds.

The most important part of this simulation is undoubtedly the graphics. These are flicker free, but rather slow. Also, from some angles, objects such as the control tower become twisted and totally unrecognisable. Having said that, the graphics are still by far the best I have seen on a Dragon flight simulator.

The other important aspect of any flight simulator is how accurately it copies the plane's responses. *Worlds of Flight* scores highly here — the program is very accurate in most situations.

Another flight simulator of a slightly different type to Microdeal's is *747 Flight Simulator* by DACC Ltd. As is obvious from the title, this program attempts to simulate the operation of a 747 Jumbo Jet. Again, two potentiometer joysticks are needed to use the program, and the display is a Pmode 4 screen with the upper half showing the pilot's view and the lower half the instrument panel.

The operating instructions come in a small booklet, the same size as a cassette case. I was somewhat surprised to see that the program is written in Basic, and this is reflected in the speed and complexity of the graphics.

The first six pages of the manual describe the theory of flying a 747 in a well written introduction, though it doesn't refer to the program or its operation at all. Next, comes a description of the instrument panel. None of the instruments are labelled, which is unhelpful as there are 16 small dials on the right-hand side of the display alone, giving information about each of the four jet engines. The other main gauges displayed are airspeed, artificial horizon, compass, speed, altimeter, rate of turn, and brake and landing gear indicators. But, each instrument is described in detail in the manual, which is generally well written.

The controls are once again via the joysticks and the keyboard. One joystick (the manual doesn't tell you which — perhaps it's more fun to find out for yourself) controls the left/right banking of the aircraft, and the rise up/down, and the other joystick is used as the throttle lever. Keyboard characters control things like brakes, landing gear, flaps etc.

The pilot's view is 3D, but you couldn't get much more basic — a couple of angled lines show the runway. Again, the operation of the aircraft is fairly accurate, which is probably why the program is so slow. If you specifically want a jumbo jet simulator, then you might consider this one.

The program itself is not bad (even if it is in Basic). Perhaps it is unfortunate that DACC's flight simulator is being compared to Microdeal's, as the latter is certainly well above the usual standard with superior features.

Program	Cost	Supplier
<i>747 Flight Simulator</i>	£9.95	DACC Ltd, 23 Waverley Road, Greater Manchester WN2 3BN
<i>Worlds of Flight</i>	£8.00	Microdeal, 41 Truro Road, St Austell, Corn- wall PL25 5JE

Draconian measures

Program: Draconian, Microdeal, 41 Truro Road, St Austell, Cornwall. **Price:** £7.95

THIS IS a space chase game that has similarities to both Phoenix and Asteroids as well as showing a certain amount of influence from Star Trek. The playing area consists of a series of interconnecting sectors, each containing several triangular enemy bases. The object is to destroy these bases and thereby free astronauts held captive inside. The astronauts have then to be transported from one sector to the next, each stage getting progressively more difficult.

After choosing the background from a selection of black, white or green, in the usual Tom Mix fashion, the display reveals the main viewing screen and a long range sector scanner on the right. The latter shows your position as well as that of the enemy bases. Your vessel remains in the centre of the playing area, but can be pointed in any one of eight different directions by means of the joystick, while a background of stars and asteroids pass by, giving the illusion of movement.

The fire button releases a stream of shots in the direction of the ship's movement which

will destroy almost anything in the way. Unfortunately, if you fly into the resulting explosion, you too end up as a space statistic.

Should you manage to collect all the astronauts, the sector scanner flashes at the top to show that the exit gate is open, and you can fly through this into the next sector. Points are awarded according to the number of astronauts safely transported through the exit gate. To liven up the game, enemy vessels called Dragons occasionally pursue you. Luckily, these can be shot down, which unfortunately is not the case with the Draconian, an unpleasant craft which appears if you take too long to destroy all the enemy bases.

There is on-screen scoring, one or two players can take part, and the game is nicely graded, getting more difficult as you progress. About the only thing I didn't like was the slow method of getting your name into the high-score table by using the joystick rather than the keyboard — a pointless hangover from the arcade version.

John Scriven



Move over pole position — here's speed racer

Program: Speed Racer, Microdeal, 41 Truro Road, St Austell, Cornwall. **Price:** £7.95

THERE HAVE been several attempts to produce motor racing games for the Dragon, but most show a view from above or from the side and fall far short of the versions available for Atari or Commodore computers. At last there is a version for the Dragon that can compete with games like Pole Position — in fact, it's surprising what excellent graphics have been achieved in Speed Racer.

When the game has loaded, the background can be selected, although to get a

really clear picture it's worth sacrificing colour in this program and choosing a black background. The title graphics are very clever and show a computer sitting on a chequered flag with the title and author's name appearing on the monitor. The screen then clears to show maps of four different circuits. Moving the joystick jumps from one to the next, and pressing the fire button selects the particular track around which you race.

The display now shows the view from just behind the car, with the track stretching away into the distance, complete with starter waving a flag. The joystick controls left and right

movement as well as acceleration and braking, and the front wheels of your car can be seen responding. The object of the game is to overtake as many other cars as possible. Indeed, should you fail to pass enough of them, you will find the game finishes after one lap. So that you know how many you need to overtake, there is an indicator at the bottom of the screen next to the speedometer.

As the race starts, one thing that is noticeable is the attention to detail. The track swings, from left to right and the background of mountains, houses, bridges, etc, moves as well, giving an excellent impression of actually being on a racing circuit. Keeping on the track is not too difficult, but there isn't much room to spare when you attempt to overtake.

Should you touch one of the other cars, there is an explo-

sion and bits of the car fly into the air, complete with relevant sound effects. You are not penalised when you have a collision, but it takes some time to catch up with the pack when you restart. If your steering isn't all it should be and you veer on to the hard shoulder too frequently, the car stops and a little figure arrives to fit a new set of tyres!

Although I enjoy well-written arcade games and simulations, it's not often that I find one that is so addictive as Speed Racer. When you've mastered the easy circuit you can go on to one with more bends. If you can last ten miles, a figure appears with a chequered flag and your time is recorded under the circuit map. One of the best games I've seen for ages.

John Scriven



Jailbreak — Cuthbert rides again

Program: Cuthbert in the Cooler, Microdeal, 41 Truro Road, St Austell, Cornwall. **Price:** £7.95

MICRODEAL HAS been producing Cuthbert games for some time now, and there seems no end to the assortment of scrapes he gets himself into. The first few were merely arcade games with a more elaborate plot, but they have gradually become graphic adventures of increasing complexity. In the latest chapter in the saga, we find Cuthbert trapped in a prisoner of war camp, in dire need of speedy release.

The first screen shows an aerial view of the camp, and the task is to get the key from one of the guards and take it to the gate. The number of guards varies according to the difficulty level chosen, and ranges from two to eight. Cuthbert has to avoid the attentions of these guards or else they will shoot at him. Luckily, the bullets travel rather slowly, and he can avoid them and even cause the guards to shoot each other, so gaining extra points. Using the fire button speeds

up his progress, but decreases the energy level.

If Cuthbert can reach the gate, he is faced with the problem of getting some identity papers from one of the guards and crossing a marsh to a bridge. Using a joystick means this task is quite difficult. The last screen sees him acquiring some money and taking a boat towards the border. The graphics aren't bad in this game, though not up to the most recent programs. Beyond the first screen the going gets quite tough, however, and you have to have very nimble fingers to reach the bridge safely. If you fail to avoid the guards, or take an early bath in the marsh, there are two more Cuthberts waiting in the wings to join the struggle for freedom.

This game has a fair amount of originality to it, but doesn't have the compulsiveness of Cuthbert in the Jungle (still my favourite), and the overall program, although reasonable, isn't quite up to others in the series.

John Scriven



The Second 6809 COLOUR SHOW

FOR DRAGON AND TANDY USERS

SATURDAY 30TH AND SUNDAY 31ST MARCH

THE ROYAL HORTICULTURAL HALLS

10 A.M. UNTIL 6 P.M.

Everyone said the first show was good!

"Over 7,000 people attended ... queues formed early ... "Dragon User, Jan 85.

"The show was a tremendous success"

Dragon Users Group.

"Many thanks for the very worthwhile 6809 show" Grosvenor Software.

This show will be even better!!

Even more to see and choose from. The very latest **hardware, software, interfaces and peripherals** will be there together with all your old favourites. Your chance to get up to date, try and buy all that's new. And pick up some **amazing bargains**.

Over 60 companies and organisations will be exhibiting with **special offers** on their products.

We'll also be organising events and competitions with **lots of prizes**. The manufacturers will be staffing **advice centres** to help with all your queries.

Large gangways and spacious rest areas will make sure you can see everything and sit in comfort when you want. The second 6809 Colour Show is a **family show**, a good day out.

HOW TO GET THERE

The Royal Horticultural Halls are just off Victoria Street a few minutes walk from Victoria or Parliament Square.

Buses 11, 24, 29, 70, 76 and 88 run up Victoria Street.

Underground stations; St. James Park (District and Circle lines), Victoria (District, Circle and Victoria lines).

There is an NCP car park in Abingdon Street, a few minutes away.

This exhibition is organised by:
Computer Marketplace (Exhibitions) Ltd.,
Part of the Rushworth Dales Group,
20 Orange Street,
LONDON WC2H 7ED

To: Computer Marketplace (Exhibitions) Ltd., 20 Orange Street, London WC2H 7ED

Please rush me 'fast lane' tickets for the Second 6809 Colour Show.

(Qty) Adult tickets at £2.00 (Qty) Under 12 year old tickets at £1.00

I enclose cheque/P.O. to the value of £_____ or debit my Access/Diner/American Express card

No. _____ Signature _____

Name _____

Address _____

Postcode _____ Telephone _____

6809 is the registered name of Motorola Ltd.

Expansion port

Hywel Francis previews a new Dragon expansion system

RACE ELECTRONICS latest offering from its armoury of add ons is a "Dragon expansion system". The expansion system comprises two separate parts, an interface cartridge with four LED indicators and the main expansion cartridge housing unit which is referred to in the users guide as the "back-plane unit". The interface is housed in an ABS plastic case with support legs, while the back-plane is manufactured out of steel that has been plastic coated.

The two units are connected by a 50-way ribbon cable. The cable is permanently connected to the back-plane, but is attached to the interface by an indirect edge connector and may be removed if you wish.

The interface cartridge holds the systems buffers and the multiplexer. Since the system is buffered, the unit can change cartridges while the back-plane is switched off, but the computer is on. The back-plane has its own power supply, which is a must. The Dragon's own power supply is totally inadequate to run four separate cartridges at any one time.

The unit uses only one location of the Dragon's memory (&HFEFF). This location is Poked with the number of the slot you wish to invoke (0-3).

6809 interrupts

Interrupts are signals to the CPU to temporarily halt what the CPU is doing and redirect it to another task. The Dragon only makes use of two of the 6809 interrupts, the Fast Interrupt ReQuest (FIRQ) and the Non-Maskable Interrupt (NMI).

The expansion unit handles any cartridge designed for the Dragon using these interrupt lines. However, problems may be encountered in the way that some cartridges handle interrupts. Switching from the slot containing this type of cartridge may result in an interrupt occurring at the switching moment, causing the processor to behave in an unpredictable manner.

To overcome this problem, the designers of the expansion unit recommend that such cartridges should be placed in any slot other than 0. The cartridge may now

be selected in the usual way. When the time comes to exit that cartridge you simply RESET the Dragon, which will default to slot 0.

One cartridge that handles the interrupts in an odd manner is Dragon Data's disk interface. Unfortunately, it holds one of the 6809 interrupt lines in an active low condition during "stand by". But Premier DOS owners will be pleased to know that their interface does not behave in a suspect way.

Figure 2

PROTOTYPE CARD	PINOUTS		
01	+12V	21	Address 2
02	+12V	22	Address 3
03	HALT	23	Address 4
04	NM1	24	Address 5
05	RESET	25	Address 6
06	E(clock)	26	Address 7
07	D(clock)	27	Address 8
08	CART	28	Address 9
09	+5V	29	Address 10
10	DATA 0	30	Address 11
11	DATA 1	31	Address 12
12	DATA 2	32	CTS
13	DATA 3	33	GND
14	DATA 4	34	GND
15	DATA 5	35	ESND
16	DATA 6	36	P2
17	DATA 7	37	Address 13
18	Read/write	38	Address 14
19	Address 0	39	Address 15
20	Address 1	40	Ext mem

One method of removing cartridges from the back-plane is to switch off its power supply while retaining a supply to the computer. However, this will affect either the FIRQ or the NMI lines causing unpredictable behaviour to the 6809 which

usually results in a crash. Race has provided information on three Poke statements within their user guide to overcome this corruption of the interrupt lines.

The 16-page users guide supplied with the system is concise and easily read. Besides containing all the pokes needed to run the system, the guide also gives details on how to utilise the Dragon 64's built-in RS232 as well as using add-on RS232 units for the 32.

Three applications are fully documented in the users guide. File transfer between Dragon DOS and the Premier Delta DOS and vice versa, BASIC and machine code programs from disk to EPROM, which can then be used in the sideways ROM board, and the third application which describes how to download a program via RS232 and store the data in EPROM.

Figure 3

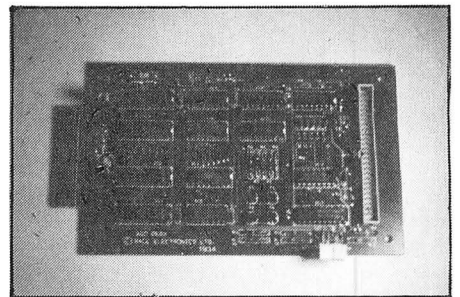

Race also included a hard copy of a relocation utility in BASIC and a 6809 assembler version written in position independent code (PIC). The utility is actually two programs in one — the first is a "keep" utility that takes the BASIC program from its original storage area and then stores it in a free part of RAM. Once the desired cartridge is selected, then the "restore" section of the utility may be invoked, which reverses the process carried out by "keep". You now have a BASIC program in the right position for execution or saving via RS232 to another computer or to EPROM.

Conclusion

This unit is extremely versatile. It really does expand the capabilities of your Dragon, whether you just wish to have four game cartridges at hand, or create a powerful 6809 development system. A great deal of thought and development time has been spent on trying to create a product that could be used with every type of commercially available and home-spun cartridge (even Dragon DOS), and it shows. The cost of the unit had not been finalised at the time of review, but it is expected to sell for around £130, which would make it a worthwhile investment. ■

Figure 1. Expansion system

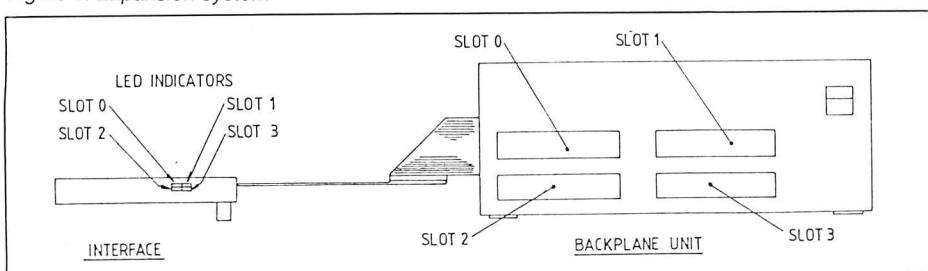

Mastermind!

Xavier Devreker presents a computerised version of the popular board game

THIS VERSION of the popular board game *Mastermind* has been written on a Dragon 32.

You have to find the right colour combination of four different colours (don't enter the same colour twice in the same line). Clues are then given in the form of a "plus" when you have found the right colour, but at the wrong place. A "green spot" is shown for a colour at the right place.

To enter a colour, just press the corresponding number (see left side of the screen). You enter them from left to right.

If, after seven guesses, you have still not found the colour combination, you have lost.

Program Notes:

10- 17: SETS FIRST PAGE
19- 38: GIVES INSTRUCTIONS
42- 89: SETS UP HI-RES SCREEN

91- 97: CHOOSES COLOUR COMBINATION AT RANDOM

99-105: ALLOWS YOU TO ENTER YOUR COLOUR COMBINATION

107-120: PRINTS OUT YOUR CHOICE

122-126: TESTS IF A COLOUR IS WELL PLACED

128-129: LOOKS IF THE FOUR COLOURS ARE WELL PLACED

131-138: LOOKS IF CORRECT COLOURS ARE AT WRONG PLACE

140-144: SETS GREEN SPOTS

146-151: SETS PLUSES

153-162: YOU HAVE LOST

164-172: YOU HAVE WON

```
1 REM *****
2 REM *M A S T E R M I N D*
3 REM *
4 REM *XAVIER DEVREKER (C)*
5 REM *
6 REM * NOVEMBER 1984 *
7 REM *****
8 REM
9 REM*****FIRST PAGE*****
10 CLS0
11 PRINT@226,CHR$(109);:SOUND20,1:PRINTCHR$(128);CHR$(128);CHR$(97);:SOUND40,1:P
RINTCHR$(128);CHR$(128);CHR$(115);:SOUND60,1:PRINTCHR$(128);CHR$(128);CHR$(116);
:SOUND80,1:PRINTCHR$(128);CHR$(128);CHR$(101);:SOUND100,1:PRINTCHR$(128);CHR$(12
8);
12 PRINTCHR$(114);:SOUND120,1:PRINTCHR$(128);CHR$(128);CHR$(109);:SOUND140,1:PRI
NTCHR$(128);CHR$(128);CHR$(105);:SOUND160,1:PRINTCHR$(128);CHR$(128);CHR$(110);:
SOUND180,1:PRINTCHR$(128);CHR$(128);CHR$(100);:SOUND200,1:PRINTCHR$(128);CHR$(12
8);
13 PRINT@431,CHR$(98);:SOUND200,1:PRINTCHR$(121);:SOUND190,1
14 PRINT@459,CHR$(120);:SOUND180,1:PRINTCHR$(128);CHR$(100);:SOUND170,1:PRINTCHR
$(101);:SOUND160,1:PRINTCHR$(118);:SOUND150,1:PRINTCHR$(114);:SOUND140,1:PRINTC
H$(101);:SOUND130,1:PRINTCHR$(107);:SOUND120,1:PRINTCHR$(101);:SOUND110,1:PRINTC
HR$(114);
15 SOUND100,1:PRINT@491,CHR$(123);:SOUND90,1:PRINTCHR$(99);:SOUND80,1:PRINTCHR$(
125);:SOUND70,1:PRINTCHR$(98);:SOUND60,1:PRINTCHR$(101);:SOUND50,1:PRINTCHR$(108
);:SOUND40,1:PRINTCHR$(103);:SOUND30,1:PRINTCHR$(105);:SOUND20,1
16 PRINTCHR$(117);:SOUND10,1:PRINTCHR$(109);:SOUND1,1
17 FOR Z=1 TO 1000:NEXT Z
18 REM*****INSTRUCTIONS*****
19 CLS7
20 PRINT@233,"INSTRUCTIONS ?";STRING$(9,239);
21 A$=INKEY$:IF A$=""THEN 21 ELSE IF A$="N"THEN 40 ELSE IF A$="Y" THEN GOTO 22
22 CLS
23 PRINT@10,"INSTRUCTIONS";
24 PRINT@42,"=====";
25 PRINT:PRINT" THE AIM OF THE GAME IS TO FIND THE RIGHT COLOUR COMBINATION."
26 PRINT:PRINT" THERE ARE SIX DIFFERENT COLOURS OR SIGNS AVAILABLE."
27 PRINT:PRINT" AFTER EACH GUESS, CLUES ARE GIVEN:";PRINT
28 PRINT" ->CORRECT COLOUR AT WRONG PLACE -PLUS-";
29 PRINT" ->CORRECT COLOUR AT RIGHT PLACE -GREEN SPOT-";
30 PRINT@488,"<PRESS SPACEBAR>";
31 A$=INKEY$:IF A$=""THEN 31 ELSE IF A$=" "THEN 32
32 CLS
33 PRINT@10,"INSTRUCTIONS";
```

```

34 PRINT@42, "===== ";
35 PRINT:PRINT" TO ENTER A COLOUR, JUST ENTER THE CORRESPONDING NUMBER.";
36 PRINT:PRINT" THE MAXIMUM NUMBER OF GUESSES IS SEVEN.";
37 PRINT:PRINT:PRINT:PRINT:PRINT" GOOD LUCK...";
38 PRINT@486, "<PRESS SPACEBAR>";
39 A$=INKEY$:IF A$=""THEN 39 ELSE IF A$=" "THEN 40
40 CLEAR 100
41 REM*****SETS SCREEN*****
42 PCLS:PMODE3,1:SCREEN1,1:COLOR6,5:PCLS
43 FLAY"01T255V20AV25AV30T20AV<T<AV<T<AV"A"
44 FOR X=9 TO 93 STEP 28
45 FOR Y=14 TO 182 STEP 28
46 CIRCLE(X,Y),9,7
47 NEXT Y,X
48 DRAW"BM121,21;U10R2F2E2R2D10L2U10D2G2H4F2D8L2"
49 DRAW"BM133,21;U10R8D10L2U4L4D4L2;BM134,16;U4R5D4L5"
50 DRAW"BM153,11;L8D1R8D1L8D4R1U4R1D4R6U1L8U1R8D4L1U4L1D4L6D1R8D1L8"
51 DRAW"BM157,11;R6D1L6D1R6L3D8L1U8L1D8U8"
52 DRAW"BM174,11;L8D1R8D1L8D8R1U8R1D8R7U1L7U1R7L7U2R4U1L4U1R4"
53 DRAW"BM182,11;R6D1L6D1R6D5L1U5L1D5L6U1R6U1L6U5D10L1U10L1D10;BM182,17;D1R1D1F1
D1R1D1R2U1L1U1L1U1L1U1L1R2D1R1D1R1D1R1D1R1"
54 DRAW"BM192,21;U10R2F2E2R2D10L2U10D2G2H4F2D8L2"
55 DRAW"BM204,21;U10R1D10R1U10"
56 DRAW"BM210,21;U10R1D10R1U10F4D2H4U2F1U4D10R1U10R1D10L2U4L2U13"
57 DRAW"BM222,11;D10R1U10R1D10R5U1L5U1R6L1U6R1D6U1R1U4L2U3L5D1R5D1L5"
58 X=200
59 CIRCLE(X,41),9,7
60 CIRCLE(X,69),7,6
61 CIRCLE(X,97),9,7
62 CIRCLE(X,125),9,8
63 CIRCLE(X,153),7,7
64 CIRCLE(X,153),2,7
65 CIRCLE(X,181),9,8
66 CIRCLE(X,181),2,8
67 PAINT(X,41),5,7
68 PAINT(X,69),6,6
69 PAINT(X,97),7,7
70 PAINT(X,125),8,8
71 PAINT(X,153),5,7
72 DRAW"BM223,33;D16R1U16R1D16"
73 DRAW"BM218,65;U4R1D4R1U4R8U1L9U1R8D6L1U6L1D6L2D1R2D1L2D1L2D1R2D1L2D1L2D1R2D1L
2D1L2R1D1L10D1R10"
74 DRAW"BM218,87;R10D1L10D1R10D14R1U14R1D14U1L12D1R10D1L10;BM226,94;L4D1R4D1L4"
75 DRAW"BM218,117;D8R1U8R1D8R10U1L10U1R10L2U3D12L1U12L1D12"
76 DRAW"BM228,144;L10D1R10D1L10D4R1U4R1D4R9U1L9U1R9D10L1U10L1D10L9D1R9D1L9"
77 DRAW"BM228,172;L10D1R10D1L10D14R1U14R1D14R6U1L6U1R6D2R2U10L1D10L1U10D2L8U1R8U
1L8"
78 LINE(120,37)-(152,45),PSET,B
79 LINE(120,65)-(152,73),PSET,B
80 LINE(120,93)-(152,101),PSET,B
81 LINE(128,37)-(136,45),PSET,B:LINE(144,37)-(144,45),PSET
82 LINE(128,65)-(136,73),PSET,B:LINE(144,65)-(144,73),PSET
83 LINE(128,93)-(136,101),PSET,B:LINE(144,93)-(144,101),PSET
84 LINE(120,121)-(152,129),PSET,B
85 LINE(120,149)-(152,157),PSET,B
86 LINE(120,177)-(152,185),PSET,B
87 LINE(128,121)-(136,129),PSET,B:LINE(144,121)-(144,129),PSET
88 LINE(128,149)-(136,157),PSET,B:LINE(144,149)-(144,157),PSET
89 LINE(128,177)-(136,185),PSET,B:LINE(144,177)-(144,185),PSET
90 REM*****COLOUR COMBINATION*****
91 FOR T=1 TO 4
92 C(T)=RND(6)
93 FOR I=1 TO T
94 IF I=T THEN I=I+1
95 IF C(I)=C(T) THEN I=T:NEXT I:GOTO 92
96 NEXT I
97 NEXT T
98 REM*****ENTER COLOURS*****
99 Y=210:SY=209
100 FOR T=1 TO 7
101 X=-19: SX=116

```

Continued on page 17

FLEX OPERATING SYSTEM

for DRAGON or DELTA disk systems
with editor and Assembler **£86.25**
special price with DBASIC **£99.99**

A reliable and easy to use operating system world. It is the ideal operating system for the DRAGON — especially when combined with our DBASIC package. requires DRAGON with 64K RAM

- 48 KBytes FREE USER RAM
- 51 by 24 Hi-Res Screen with true lowercase, autorepeat, redefinable character sets, windows etc . . .
- Supports single and double density for interchange with other FLEX systems
- includes over 30 standard utilities
- Powerful Macro Assembler
- Verstile Text Editor

DBASIC

£30.00

- Standard 32K DRAGON BASIC
- 32 by 16 Screen and 51 by 24 Screen
- Send Commands to FLEX from BASIC
- Use up to 8 sequential or random access files simultaneously
- ERROR GOTO statement to intercept errors
- ERROR command shows you exactly where BASIC detected an error
- Load/Save programa as FLEX disk files
- Includes 5 example programs

DRAGON FLEX UTILITIES

£35.00

An invaluable collection of useful utilities for FLEX on the DRAGON including: DEMON, 6809 disassembler, improved file copy, single sector copy, extend file, extend directory, change memory end, fill, dump, improved list, map binary file, graphics dumps, RS 232 terminal interface — and more.

DYNACALC

£69.95

Full feature spread-sheet system for business and scientific use

RMS

£69.95

Powerful but easy to use general-purpose data management system. Allows you to input and retrieve records by index, sort and produce reports.

EDIT +

for DRAGON FLEX **£19.95**

DYNAFAST

for DRAGON FLEX **£19.95**
with DYNAMISER/DYNAXREF

EXTRAS

DUST COVER **inc p&p £2.99**
PRINTER LEAD **inc p&p £14.99**
MONITOR/SOUND LEAD **inc p&p £3.99**

DISC DRIVE UPGRADE KIT

£120

DRAGON DATA 2nd disk drive with full instructions

FLEX SOFTWARE

For all FLEX systems
X BASIC **POA**
X BASIC PRECOMPILER **POA**
6809 DEBUG **POA**
FLEX DIAGNOSTICS **POA**
PASCAL **POA**
Public Domain Small C **£24.95**
Compiler (includes full source and documentation on disk only)

CROSS ASSEMBLERS

6800/2 6801/3 6301 6805 6502 8080/5
Z80 macros, library file calls — all the features of the FLEX 6809 assembler
£51.75 each all 7 for **£201.25**

DYNAFAST

with DYNAMISER/DYNAXREF
DRAGON BASIC COMPILER

Cartridge **£29.95**
DRAGON DOS disk **£19.95**

Phone/write for availability of DRAGON HARDWARE, OS9 Software, TANDY Colour Software

EDIT +

is a Full Screen Editor and Programmer's Tool Kit. It's an excellent aid for writing programs in BASIC and is easy to use for the novice as well as the experienced programmer. EDIT+ includes all the facilities of HI-RES. Up to 23 lines of your program are displayed on the screen and can be changed by overtyping, inserting, or deleting characters. Functions include: Find String, Change String, Copy Text, Goto Specified Line, Scroll Up Down, Append From Tape and Enter Basic Command. No Dragon is complete without an EDIT+.

Cartridge **£34.50**
Dragon DOS Disk **£24.00**

COLOSSAL CAVE ADVENTURE

NEW!
£9.95

This classic adventure game is now available for the DRAGON. Requires 64K and a DRAGON/DELTA disk.

PROFESSIONAL BUSINESS SOFTWARE

Available now for OS9 — soon for FLEX

Cash and Vat — Stock Recording
Sales Ledger — Purchase Ledger
Invoicing — Labelling
£49.95 each — All six titles £199.95

BOOKS

Introducing Dragon Machine Code by Ian Sinclair **£7.95 p&p £1.00**
Dragon m/c Jones and Causill **£7.95 p&p £1.00**
6809 m/c Leventhal **£14.00 p&p £1.80**

DASM

is a versatile assembler, designed especially for ease of use on the DRAGON and allows you to assemble machine code while still retaining the full use of BASIC. Supports all 6809 instructions and modes. Allows any length for labels (the first 5 and the last characters are used). Full support for output to printer. recommended for the beginner.
Cartridge **£18.95**

DEMON

A powerful machine code monitor which allows you to delve into the internals of your DRAGON as well as helping you to debug your machine code programs (and BASIC programs using PEEK and POKE). Includes: Examine/Change memory, Examine/Change registers, Print screen, Set Breakpoints, Test/Memory. An essential tool for all machine code users.
Cartridge **£18.95**

DASM/DEMON

It has all the features of both DASM and DEMON in one package. DEMON is the natural partner to DASM, complementing each other perfectly. Write, test and use your programs without the bother of reloading. It is extensively featured in the new book by Ian Sinclair on Dragon Machine Code. It is the ideal combination for the machine code user.
Dragon DOS Disk **£19.95**
Cartridge **£30.45**

FAST MAIL ORDER SERVICE 01-882 0681

 **COMPUSENSE LIMITED**



Box 169, 286D Green Lanes, Palmers Green, London N13 5XA
Tel: 01-882 0681/6936 24hr
Telex: 8813271 GECOMS G

PRICES INCLUDE VAT

**POSTAGE AND PACKING —
50p PER ORDER**

```

102 Y=Y-28:SY=SY-28
103 FOR I=1 TO 4
104 X=X+28
105 CH$=INKEY$:IF CH$<"1" OR CH$>"6" THEN 105
106 REM*****SETS COLOURS*****
107 CH(I)=VAL(CH$)
108 IF CH(I)<>1 THEN 110
109 CIRCLE(X,Y),9,7
110 IF CH(I)<>2 THEN 112
111 CIRCLE(X,Y),9,6:PAINT(X,Y),6,6
112 IF CH(I)<>3 THEN 114
113 CIRCLE(X,Y),9,7:PAINT(X,Y),7,7
114 IF CH(I)<>4 THEN 116
115 CIRCLE(X,Y),9,8:PAINT(X,Y),8,8
116 IF CH(I)<>5 THEN 118
117 CIRCLE(X,Y),9,7:CIRCLE(X,Y),2,7
118 IF CH(I)<>6 THEN 120
119 CIRCLE(X,Y),9,8:CIRCLE(X,Y),2,8
120 NEXT I
121 REM*****RIGHT COLOUR*****
122 CR=0
123 FOR P=1 TO 4
124 IF C(P)<>CH(P) THEN 126
125 CR=CR+1
126 NEXT P
127 REM*****END OF GAME?*****
128 IF CR=4 THEN 164 ELSE GOTO 131
129 IF T=7 THEN 151
130 REM*****WRONG PLACE*****
131 RP=0
132 FOR P=1 TO 4
133 FOR N=1 TO 4
134 IF N=P THEN N=N+1
135 IF C(P)<>CH(N) THEN 137
136 RP=RP+1
137 NEXT N
138 NEXT P
139 REM*****SETS GREEN SPOTS*****
140 IF CR=0 THEN 146
141 FOR P=1 TO CR
142 SX=SX+8
143 PAINT(SX,SY),6,6
144 NEXT
145 REM*****SETS PLUS*****
146 IF RP=0 THEN 151
147 FOR P=1 TO RP
148 SX=SX+8
149 CIRCLE(SX,SY),2,6
150 NEXT P
151 NEXT T
152 REM*****YOU LOST*****
153 CLS
154 FOR YL=0 TO 480
155 PRINT@YL,CHR$(128);"Y O U L O S T . . . ";
156 NEXT YL
157 PRINT@384,"*****";
158 PRINT@416,"<P R E S S S P A C E>";
159 PRINT@448,"*****";
160 PLAY"V3101T2L46GL8B-AAGGF#G"
161 Q$=INKEY$:IF Q$=""THEN 161 ELSE IF Q$=" "THEN 40
162 GOTO 40
163 REM*****YOU DID IT*****
164 CLS
165 FOR YD=1 TO 480
166 PRINT@YD-1,CHR$(128);"Y O U D I D I T ! !";
167 NEXT YD
168 PRINT@416,"*****";
169 PRINT@448,"<P R E S S S P A C E>";
170 PRINT@480,"*****";
171 PLAY"Q2V31T5L8GAA#B03C02GAGE01C03C"
172 Q$=INKEY$:IF Q$=""THEN 172 ELSE IF Q$=" "THEN GOTO 40

```

Doodling

John Smith presents a turtle graphics type drawing program

SINCE IT is not too difficult to write a program which allows drawing on the Dragon's hires screen, with the ability to give a screen dump on to the Tandy CGP 115, I decided to dabble with something approaching turtle graphics. The short listing which follows is approximately 2.5K long, and quite easy to enter. Even if you have not got a Tandy (or similar) printer/plotter, you will still get some preliminary insight before investing in a full scale professionally written package.

Only four commands are used and, since this is by no means a full implementation of turtle graphics and the finished drawing often resembles the doodles on the corner of my memo pad, I have corrupted the name to my title — "DOOTLE".

On running the program you are first presented with two introductory screens with instructions for entering data. At start up, the program sets the drawing turtle at the centre, and facing towards the top of the screen (ie, to 12 o'clock on a clock face).

The first request is to ENTER the length of the line that you want the turtle to draw. The units used are single pixels in Pmode 4. This means that a line going in any direction of a length greater than 128 from the centre will give an error message of being off screen. Lengths of 40-50 should be sufficiently large to produce a useful size without producing this error.

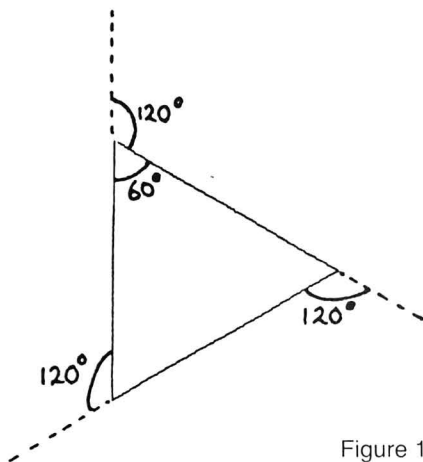

Figure 1

The next request is for an angle. Since the turtle is facing up at the start, an input of 90 means that the first line will be drawn to the right (or 3 o'clock) while an input of 120 will draw to 4 o'clock, and so on. The next command appears as REPEAT,

which refers to the number of times you want the line of the length you have entered to be drawn at the specified angle.

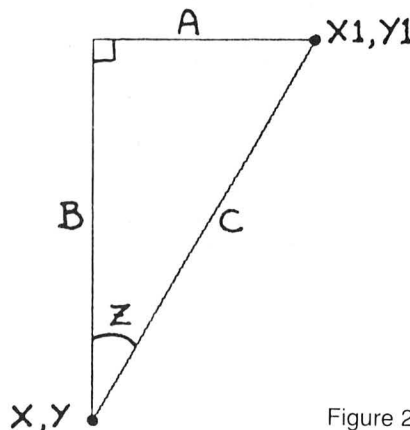

Figure 2

If we take a line of 40 units and an angle of 120 degrees drawn three times, we will end up with the drawing in Fig 1. You will see that the rotation of the line is clockwise (although this can be altered to anticlockwise by entering a negative value for the

angle) and that the angle is on the outside of the triangle ie you do not specify 60 degrees to draw a triangle.

This gives a simple rule for drawing polygons, namely 360/number of sides = the angle to be used for drawing. Thus, a pentagon is drawn by 72 degree angles and an octagon by 45 degrees. With a sufficiently large number of sides, the drawing approaches a circle (try angles of 10 degrees repeated 36 times).

The whole program relies on simple trigonometry to produce its effects and the equations used are at the subroutine on line 3000. Fig 2. helps explain how these equations are derived:

Since $\sin Z = A/C$ and $\cosine Z = B/C$
 $A = C \times \sin Z$ and $B = C \times \cosine Z$.
 Therefore $X1 = X + A$ and $Y1 = Y - B$.

Each time the subroutine is called, X1 and Y1 are recalculated for each increase in angle by Z (Z being the angle converted to radians by dividing by 180/pi, which equals 57.29577951).

The command to vary the line is LENGTH VARIATION. This changes the

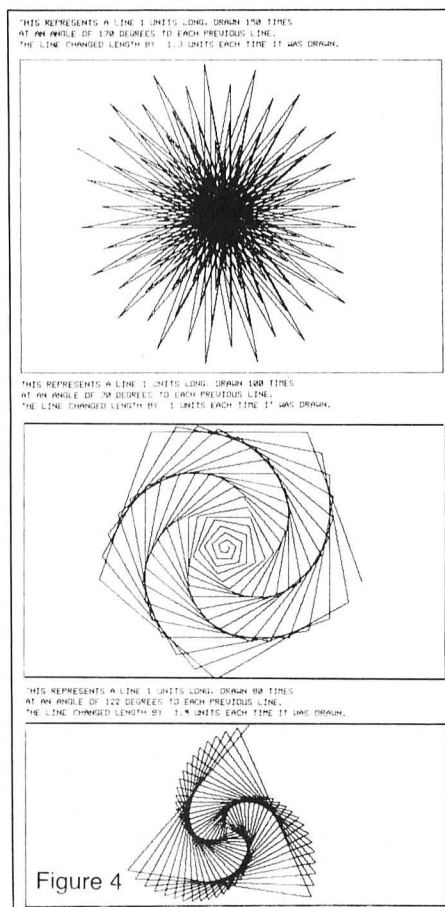

Figure 4

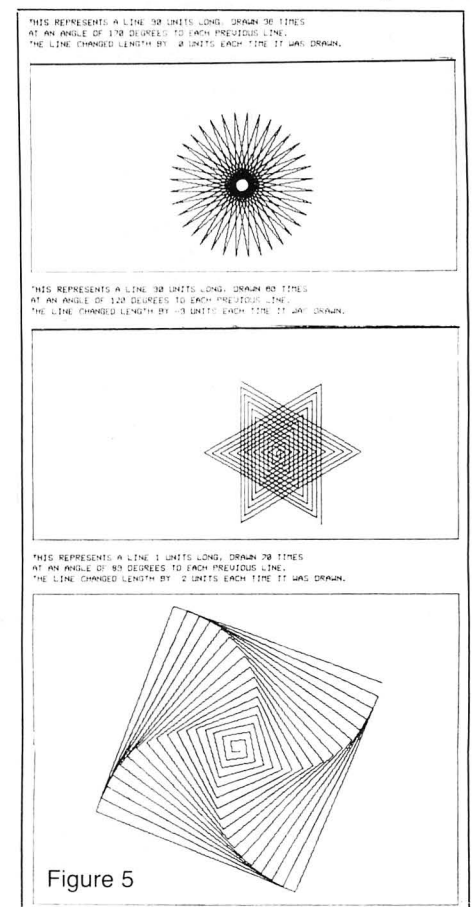

Figure 5

original line length by one unit each time it is drawn (negative values giving a reduction and positive ones an increase). To take the triangle again, if the line is drawn six times reducing it by two units each time we end up with Fig 3.

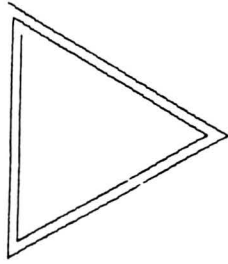

Figure 3

These are just some suggestions and you will find that with experimentation some very interesting results can be obtained. Try the values given in the accompanying table.

Length	:Angle	:Repeat	:Variation
1	170	150	1.3
1	70	100	1
1	83	50	1
60	100	18	0
90	170	36	0

Having entered your values the program then draws, in high resolution. If, however, any of the values are such that the drawing will go outside the screen area, then an error message to that effect will appear. You are then returned to the values entry stage again. Note that the previously entered four values always remain on screen, so you can adjust one or more of these to try to bring the drawing back on to the screen again.

If the drawing is completed, it remains on view for a short time and then you are returned to the text screen with three choices: 1) View the drawing again by pressing the spacebar (and return to text screen by pressing any key). 2) Start a new drawing (again the previous values remain to give you something to work from

to obtain any particular effect). 3) Dump the drawing to the Tandy CGP 115 printer/plotter.

If you do not have a printer/plotter then you can make the screen output more interesting by changing program lines 70 and 190 as follows:

PROGRAM LISTING

Numeric Variables

P = Print position for input of data.
 U = Print position for error and help messages.
 C = Length of line.
 S = Angle to draw line.
 T = Number of lines to draw line.
 C1 = Change in length of line.
 C2 = Temporary storage for length variable (C), to allow trigonometry functions to be calculated.
 X,Y = Starting point for drawing each line.
 A,B = Relevant variation in X and Y for each

```
70 X=128:Y=96:RR=0:Pmode3,1:
PCLS5
190 COLORRND(3)+1:LINE(X,Y)-(X1,Y
PSET
```

This gives a random coloured design which is even more effective. Happy Doodling. ■

direction change.

X1,Y1 = End point for drawing each line.
 RR = Starting direction for each line.
 R = New angle for next calculation (=S+RR).
 Z = Angle R in radians.
 D = Loop variables.
String Variables
 P\$ = Inverse space character.
 PR\$ = Inverse "PRESS" (to save program space).
 Q\$ = Reads key pressed for continuing with the various program functions.

PROGRAM STRUCTURE.

10-50	Introductory screens with instructions.	
60	Set variables and clear text screen to black.	220
70	Set up Hires screen and start-point at centre, with initial direction towards 12 o'clock.	230
80-110	Enter data for program to carry out drawing (subroutine 5000 blanks out previous values).	240
120	Gosub 6000 — clear screen and print drawing parameters.	250
130	Store length in a separate variable to allow calculation of trig. functions without altering starting length.	260
140	Make Hires screen visible.	270
150	Draw limits of usable screen area.	Subroutines
160-210	Set up loop to draw lines the required number of times.	500
170	Gosub 3000 — Set old line direction (RR) to new direction (R) by adding angle parameter (S) and convert this to radians (Z). Using Z calculate changes in position for drawing to X1 and Y1	2000
180	If drawing goes off screen, put up error message (subroutine 1000).	2010
190	Where all the action takes place. This draws each new line.	2020
200	Subroutine 4000 — change all drawing end points to the next start points and change length of line if so required.	2040
		2050
		2060
		2080/2090
		2100
		2110
		8000

```
1 '*****
2 '**** DOOTLE ****
3 '**** BY ****
4 '****J.A. SMITH****
5 '**** 11/10/84 ****
6 '*****
10 CLS
20 PRINT@13,"DOOTLE"
30 PRINT@99,"THIS IS A DEMONSTRATION OF
DRAWING USING SEMI-TURTLE COM
MANDS, WITH THE ABILITY TO OUTPUT H
ARD COPY..... if a printer is con
nected.":PRINT:PRINT:PRINT:PRINT:PRINT"
PRESS SPACEBAR TO CONTINUE":GOSUB8000:
GOSUB500:CLS
40 PRINT@64,"YOU WILL BE ASKED TO enter
FIRSTTHE length OF LINE AND THEN THE ang
le AT WHICH SUBSEQUENT LINES ARE TO BE D
RAWN.THE NEXT REQUEST IS FOR THE NUMBER O
F TIMES YOU WISH TO repeat THIS ACTION.
```

THE FINAL INPUT IS HOW MUCH YOU WANTTHE LINE TO";

```
50 PRINT" vary BY EACH TIME ITIS DRAWN.
( USE NEGATIVE VALUESTO DECREASE.)":PRI
NT:PRINT:PRINT" PRESS SPACEBAR TO CONT
INUE":GOSUB8000:GOSUB500
60 P$=CHR$(128):P=96:U=352:PR$="press":C
LS0
70 X=128:Y=96:RR=0:Pmode4,1:PCLS5:COLOR0
,5
80 GOSUB5000:INPUT"length";C
90 GOSUB5000:GOSUB500:INPUT"angle";S
100 GOSUB5000:GOSUB500:INPUT"repeat";T
110 GOSUB5000:GOSUB500:PRINT"length";P$;
"variation";:INPUTC1
120 GOSUB6000
130 C2=C
140 SCREEN1,1
150 LINE(0,0)-(255,191),PSET,B
160 FORD=1 TOT
```

Figure 6

Continued on page 21

Designed and produced by qualified professional educationalists

EDUCATIONAL SOFTWARE

Physics (O level/CSE Revision)
Biology (O level/CSE Revision)
Computer Studies (O level/CSE)
Maths (O level Revision)
Maths (CSE Revision)
Science (Revision 12/14 years)
Chemistry (O level/CSE Revision)

Maths (Revision 12/14 years)
English (Revision 12/14 years)
Reasoning (11+ Revision)
English Practice (8/11 years)
Mathematics Practice (8/11 years)
Arithmetic Practice (7/10 years)

Tables (Practice 7/11 years)
Spelling (Improver 9/99 years)
Knowledge Quiz (9/99 years)
Sports Quiz (9/99 years)
Typing (Improve your speed and accuracy — timed tests in upper and lower case letters — 100% high res.)

UNBEATABLE VALUE AT £4.95 EACH POST FREE

O LEVEL/CSE COMPUTER STUDIES

A set of four cassettes jam-packed with up to date knowledge covering the O level/CSE syllabuses. Full tutorial with revision questions. Subject areas include:

Data Coding, Data Storage, Computer Arithmetic, Computer Logic, Processing Information, Society and Computers, Computer Structure, Backing Storage.

And much, much more.

Also suitable as a general introduction to the computing world (Mums and Dads please note).

FANTASTIC VALUE AT £14.50 PER SET POST FREE.

PRO-FILE ©

The original and best cassette-based filing system. Use your Dragon as a data filing and retrieval system. Hundreds of uses throughout the home and small business — used by doctors, dentists, farmers, etc.

Output to screen or printer.

56-page easy-to-use manual with full instructions.

"Profile does everything it claims and does it well (*Which Micro?* November 1983).

"One of the best manuals of its type I have seen, ideal for the novice" (*PCW* December 1983).

£5 less than our nearest rival.

£9.95 post free

MICRO DE-BUG CONSULTANCY

Dept U, 60 Sir Johns Rd, Selly Park

Birmingham B29 7ER. Tel: 021-472 7610

Also suitable for Tandy CoCo Computer



of the hill!

The *RAINBOW* is the biggest and best magazine available for the TRS-80® Color, TDP-100, MC-10 and Dragon-32 Computers.

And no wonder! It's over 300 pages thick each month . . . pages brimming with programs, product reviews, tutorials, columns, hints and tips about *your* computer. Yes, it is considered "the" Color Computer magazine to buy.

Don't delay. For only \$28 you can get the *Rainbow* every month of the year. Then *your* CoCo will be Kong of the Hill too!

**U.K. Subscription rates
U.S. \$65 surface rate
U.S. \$100 air rate**

the *Rainbow* 9529 U.S. Highway 42
502/228-4492 PO Box 209
Prospect, Ky 40059

YES! Sign me up for a year (12 issues) of the *RAINBOW*.

Name _____
Address _____
City _____ State _____ Zip _____
Payment Enclosed _____
Charge VISA MasterCard American Express
My Account# _____ Interbank# (MC only)
Signature _____ Card Expiration Date _____



Subscriptions to the *RAINBOW* are \$28 a year in the United States Canadian and Mexican rate U.S. \$35, surface rate to other countries U.S. \$65, air rate U.S. \$100. All subscriptions begin with the current issue. Please allow up to 5-6 weeks for first copy.

Just for your
TRS-80® COLOR
TDP System 100
Dragon-32
MC-10

```

170 GOSUB3000
180 IFX1>255ORX1<0ORY1<0ORY1>191 THENGOS
UB1000:GOSUB6000:GOTO70
190 LINE(X,Y)-(X1,Y1),PSET
200 GOSUB4000
210 NEXTD
220 FORK=1 TO5000:NEXT
230 PRINT@U,"to";P$;"view";P$;"again";P$
;PR$;P$;"SPACEBAR";P$;P$;P$;P$;"then";P$
;"any";P$;"key";P$;"to";P$;"return";STRI
NG$(10,128);"to";P$;"use";P$;"printer";P
$;PR$;P$;"P";STRING$(10,128);"to";P$;"dr
aw";P$;"again";P$;PR$;P$;"D";STRING$(11,
128);
240 Q$=INKEY$
250 IFQ$="P" THENGOSUB500:GOSUB2000
260 IFQ$=" " THENGOSUB500:GOSUB7000
270 IFQ$="D" THENGOSUB500:GOTO70ELSE240
500 PLAY"05L50C":RETURN
1000 SCREEN0,1:PRINT@U,"outside";P$;"ava
ilable";P$;"screen";P$;"area";STRING$(3,
128);"reduce";P$;"value";P$;"of";P$;"one
";P$;"or";P$;"more";STRING$(5,128);"entr
ies";:FORK=1 TO5000:NEXT:PCLS5:RETURN
2000 C2=1.8*C:C1=1.8*C1:X=230:Y=172:RR=0
2010 PRINT#-2,CHR$(18):PRINT#-2,"S0":PRI
NT#-2,"A"
2020 PRINT#-2,"THIS REPRESENTS A LINE";C
;"UNITS LONG, DRAWN";T;"TIMES":PRINT#-2,
"AT AN ANGLE OF";S;"DEGREES TO EACH PREV

```

```

IOUS LINE.":PRINT#-2,"THE LINE CHANGED L
ENGTH BY ";C1/1.8;"UNITS EACH TIME IT WA
S DRAWN."
2030 PRINT#-2,CHR$(18):PRINT#-2,"M230,-1
72":PRINT#-2,"D230,-172"
2040 FORD=1 TO 1:GOSUB3000
2050 PRINT#-2,"D";X1,"";-Y1
2060 GOSUB4000
2070 NEXTD
2080 PRINT#-2,"M0,-350"
2090 PRINT#-2,"D480,-350,480,0,0,0,0,-35
0"
2100 PRINT#-2,"A"
2110 C1=C1/1.8:RETURN
3000 R=S+RR:Z=R/57.29577951:A=INT((C2*S1
N(Z))+.5):B=INT((C2*COS(Z))+.5):X1=X+A:Y
1=Y-B:RETURN
4000 RR=R:X=X1:Y=Y1:C2=C2+C1:RETURN
5000 PRINT@P,STRING$(32,128);-PRINT@P,"
";:RETURN
6000 CLS0:GOSUB500:PRINT@0,"length";C,"a
ngle";P$;P$;P$;P$;S,"repeat";T,"variatio
n";C1:RETURN
7000 SCREEN1,1:Q$=INKEY$:IFQ$=" " THEN7000
ELSESCREEN0,0:RETURN
8000 Q$=INKEY$:IFQ$<>" " THEN8000ELSERETU
RN
Please note that lower case lettering
represents inverse characters on the
DRAGON, i.e. SHIFT key with 0.

```

PRICES
SLASHED

Action-packed
100% machine code
arcade software

all **£3.95**

GUARANTEED
same-day despatch

TASKSHIP

This game in the Scramble series has two great innovations. The first is that YOU can design your own scenario (with rockets, mountains, buildings and radar dishes where you want), or use the ready designed format. The second is the black holes which pull you off course. If you are unfortunate enough to disappear into a black hole, you get time warped to another part of the landscape. Brilliant graphics.

£3.95



MAURICE MINOR. Out for a quiet drive in your Morris Minor you inadvertently wander on to a race track and find yourself in the middle of a Grand Prix!

£3.95

MISSION XK1: Penetrate the asteroid belt to land on the planet Zyphon and collect liquid Zyphonium fuel. **£3.95**

DROIDS: Stop the Droids removing lead shields to release the bombs which will destroy the world. **£3.95**

DRAGON 2: Snakes, Lander and Invaders. 3 games for **£3.95**

DRAGON 4: Pterodactyl, Torpedo Run and Hornets. 3 games for **£3.95**

CHESS: 8 selectable levels of skill, cursor control of moves, supports Castling and En Passant. **£3.95**

VULTURES: Galaxian-type game in which a flock of vultures guard their eggs. Just when you think you've killed them all, the eggs hatch! **£3.95**

BONKA: Climb the ladders and dig holes to trap the "Meanies" before they kill you. **£3.95**

POGO-JO

Q-Bert type game with amazing sound and graphics, unlike anything seen before on the Dragon. The player can choose to start on any one of 15 completely different screens, and select one of the 4 skill levels. Features include Hall of Fame, return to last screen on which killed for next game, positive joystick control.

£3.95

SKYJOUST: Fight for the supremacy of the sky from the back of your battle ostrich, specially trained to joust. **£3.95**

STARFIGHTER: The hostile landscape scrolls beneath your starfighter. You bob and weave under joystick control and you seek and destroy the enemy fighters and ground installations. **£3.95**

LASERGATES: Can you escape the robot guardians who pursue you relentlessly through the maze of ancient passages. **£3.95**

MICROS Crusader



CRUSADER: In quest of the Holy Grail you, our intrepid hero, have to overcome seven increasingly difficult stages to reach your goal. No one has yet made it!

£3.95

COPTER PATROL

Fly your helicopter over hostile territory to rescue your stranded troops from the enemy. Your men will wave to you to attract your attention and then run to the helicopter when you land. Unfortunately, the enemy fighter planes and battleship guns home in on you to give you very little time for a safe pick up.

RIVER OF FIRE: An adventure. Superb machine code animated graphical scenes make this probably the best adventure yet for the Dragon. The volcano erupts on your island. Can you save yourself and help the hospital patients to safety. You'll need cunning and perseverance. **£3.95**

EDITOR/ASSEMBLER + DISASSEMBLER + MONITOR

Two pass global type. Supports labels of six characters. Directives. ORG, RMB, FCB, FDB, FCC, REM. Hexadecimal Arithmetic. Powerful debug Monitor includes 14 commands plus set break points, selection of useful sub-routines and Disassembler. Altogether a powerful program package with information for the serious user or interested beginner. Supplied on cassette.

NOW ONLY £7.95

Add 50p P&P for orders under £5.00

J. Morrison (Micros) Ltd
Dept DU385, 4 REIN GARDENS,
TINGLEY, WEST YORKSHIRE WF3 1JR



ORDER NOW!
Telephone (0532) 537507
and use your Access card
Guaranteed same day despatch.



Sequential files on tape

Robin Hamilton explains how sequential file techniques can be used to create a 200K database on tape

THERE ARE numerous data-base programs in existence for the Dragon 32, from the simplest to the most complicated, both commercial tapes and listings published in magazines. Unfortunately, most that rely on cassette rather than disk for data-storage have a radical limitation — they accept the 32K memory of the Dragon as an upper limit for the total amount of data which the program can deal with.

For simplicity's sake, "32K" is used as shorthand for whatever amount of memory is left for string-data, after the Basic program has taken its byte, and the memory has been further used up by

dimensioning arrays, assigning variables, and so on. This will obviously be less, often much less, than the notional 32K available initially after PCLEAR1 has been executed.

The following sort routine is a standard version of the Shell sort, but it makes use of the Dragon's VARPTR function. It can be between five and 10 times faster than a sort program which directly switches arrays rather than (as this does) switching the array pointers (N = number of items to be sorted and D\$(number) is the array holding these items).

Next, you should examine the LOAD

and SAVE routines. These come in two forms. The simpler reads or writes a number at the start which gives the number of items in the array to be saved or loaded. This number is then used when reading or writing data to or from tape, to indicate when to stop loading or saving. For our purposes, this is quite useless as it effectively prevents a file on tape from being appended to one already in the computer. The routine to use, more complicated but more elegant, is the one which employs the Dragon EOF function.

There are a number of techniques which can be used to extend this limit to the maximum amount of data which can be held on cassette rather than in Ram. Conceivably, a two-hour audio-cassette could be used to hold the data, but there is an overhead in terms of time — accessing the final item of data on a two-hour cassette, however you go about it, does take two hours. But, using the techniques described here, it should be possible to create a database of about 200K on a C20 cassette, and access it relatively easily.

Original database

There are certain features your original database program should have. These are:

- Routines to create files
- Routines to insert, amend, and delete records
- Routines to load and save data to tape
- Routines to search for records
- A sort routine to arrange the records in order

All these routines are fairly standard. The only one which is sometimes omitted from database programs is the sort routine. If you are buying a database program, or building one from scratch, make sure you pick one with a sort routine. If you have a database program without a sort routine, write one in as a subroutine.

Here are the bad and the good versions (Figs 2 and 3) — if you have the former, simply replace it by the latter. Both versions presuppose a variable N in the program which holds the number of items currently in the file, and an array D\$(large number greater than N) created by the program to hold the records.

The purpose of the variables in line

```
7500 REM *** SORT SUBROUTINE ***
7505 N=N-1
7510 CLS: PRINT "SORTING ... PLEASE WAIT"
7520 Y=1
7530 Y=2*Y
7540 IF Y<N THEN 7530
7550 Y=INT((Y-1)/2)
7650 IF Y=0 THEN 7730
7660 IT=N-Y
7670 FOR I=1 TO IT
7680 J=1
7690 W=J+Y
7700 IF D$(W)<D$(J) THEN 7740
7710 NEXT I
7720 GOTO 7550
7725 CLS: PRINT "SORT COMPLETED"
7730 N=N+1: RETURN
7740 FOR C=0 TO 2
7750 B=C: IF B>0 THEN B=B+1
7760 Y1=PEEK(VARPTR(D$(W))+B)
7770 Y2=PEEK(VARPTR(D$(J))+B)
7780 POKE(VARPTR(D$(W))+B),Y2
7790 POKE(VARPTR(D$(J))+B),Y1
7800 NEXT C
7805 J=J-Y
7810 IF J>0 THEN 7690
7820 GOTO 7710
```

Fig 1

1005, and their use in line 1020, rather than the more obvious 1 TO N, will emerge in due course. This part of the routine is actually simpler than the earlier version, since you don't have to print the number to the tape to start with!

This routine is at once more elegant and less easy to understand than the earlier version. What it does is read the tape and, if the end-of-file marker is encountered, return from whence it was called. Otherwise, it increments the variable counter holding the number of items in the file by one, reads one data item from the tape into the array set up in the program to hold the records, and then repeats the process until the end-of-file marker is found. At this stage, it will return to the main program with N set to the number of items currently in the file. If there is no data in the program to start with, then N will equal the number of items loaded; if the program already holds data, then N equals the number of items held plus the number of items loaded.

```

1000 REM *** BAD SAVE ROUTINE ***
1010 OPEN "O", #-1, "DATA"
1020 PRINT #-1, N
1030 FOR A=1 TO N
1040 PRINT #-1, D$(A)
1050 NEXT A
1060 CLOSE #-1
1070 RETURN

1200 REM *** BAD LOAD ROUTINE ***
1210 OPEN "I", #-1, "DATA"
1220 INPUT #-1, N
1230 FOR A=1 TO N
1240 INPUT #-1, D$(A)
1250 NEXT A
1260 CLOSE #-1
1270 RETURN

```

Fig 2

Incidentally, if you want to save a string beginning with double quotes, simply replace INPUT by LINE INPUT. This follows the same syntax and has the same constraints as LINE INPUT taking data from the keyboard.

With a SORT routine included, and the EOF version of the LOAD/SAVE routine, we now have the program running and can work within the 32K limit. Now we add the frills.

```

1000 REM *** GOOD SAVE ROUTINE ***
1005 B=1 : E=N
1010 OPEN "O", #-1, "DATA"
1020 FOR A=B TO E
1030 PRINT #-1, D$(A)
1040 NEXT A
1050 CLOSE #-1
1060 RETURN

1200 REM *** GOOD LOAD ROUTINE ***
1210 OPEN "I", #-1, "DATA"
1220 IF EOF(-1) THEN CLOSE #-1: RETURN
1230 N=N+1
1240 INPUT D$(N)
1240 GOTO 1220

```

Fig 3

The first frill is the ability to APPEND files from tape, which will be essential later. This will enable you to create two separate files, add them together, and

merge them using the SORT routine (assuming, that is, that the files are in the same form — for example, simple strings held as part of a string array). Even this by itself can be useful, if you can imagine five separate Dragon programmers each putting some items into a database on their individual computers, then getting together to combine the files. In certain situations,

with the second part of the original file and the second part of the new file. Save this file on the same tape that you saved the combined part one, immediately after it. If this is done correctly, you will now have a cassette containing approximately 60K of data in an ordered sequence.

The purpose of the variables B and E should now have emerged — they allow us

```

2000 REM *** SPLIT FILE IN TWO ***
2010 INPUT "BREAK FILE AT WHICH LETTER"; L$
2020 M=1
2030 IF LEFT$(D$(M))>L$ THEN 2050
2040 M=M+1 : GOTO 2030
2050 INPUT "PRESS ANY KEY TO SAVE FIRST FILE"; K$
2060 B=1 : E=M-1
2070 GOSUB 1010
2080 INPUT "PRESS ANY KEY TO SAVE SECOND FILE"; K$
2090 B=M : E=N
2100 GOSUB 1010
2110 PRINT "SAVE COMPLETED"
2120 RETURN

```

Fig 4

this would spread the misery of data-entry five ways.

When the program is first run, N is set to 1. This is because the program creates an end-of-tape marker when it is set up, which will always come at the end of the final file in a series on tape. The main menu will present an option "3. LOAD FILES FROM TAPE". When option 3 is chosen, you're sent to the LOAD subroutine at line 1200, the file is loaded from tape, and N is now set to the current number of items in the file. To append a further file, simply use the same option as it stands.

As the new file is loaded, N is incremented by 1 as each record is input, and when the file has finished loading, you're returned to the main menu with N now reset to the number of items in the file currently held by the program. You can now carry on adding files up to the limit of the computer memory, and merge these files into one by means of SORT.

Assuming that we have now created a data file which takes up the whole of the available computer memory, and wish to add to this, what do we do? This is the second frill, the reverse of APPENDING files. We break the file into two parts (Fig 4).

By the use of this routine, we can create two separate files, each of which (ideally) will take up approximately half of the available computer memory. Further items can now be loaded into the file.

First, start a completely fresh file and insert records up to the limit of available memory, or until you reach a convenient point to process this file. SORT this new file into order, and divide it into two at the same point that you divided your original file. Clear the program, and load in the first part of the original file, then append the first part of the new file to this, sort the result, and save the new, large sorted file on a fresh tape.

Next clear the program and do the same

to break into the SAVE routine and specify which parts of the file currently in the program are to be saved. They would originally be set up as part of an initialisation routine something like the example in Fig 5.

The process of splitting files, adding to them, and recombining, can be done indefinitely, up to the limit of data that the cassette can hold. The problem with this is that only part of the data can be held in the Dragon's memory at any one time.

```

100 PCLEAR1 : CLEAR 20000
110 DIM D$(300)
120 N=1 : B=1 : E=1
130 D$(N)="ZZZZZ"

```

Fig 5

```

10 CLS
100 PCLEAR1: CLEAR 20000
110 DIM D$(300): DIM T$(30)
120 N=1 : B=1 : E=1: CT=1
130 D$(N)="ZZZZZ"

```

Fig 6

To get round this problem, we create a routine to search each of the files on tape one after the other, and to store the results of this search in an array which has been created specially to hold them. At the moment, our initialisation routine has created an array D\$(x) to hold our records, and sets N=1 : B=1 : E=1. We now add T\$(30), to create an array of 30 elements to hold items found by the search program, and a variable flag CT, which will signal whether the search routine is to simply scan the file currently in memory, or is to load further files and scan these too. The beginning of our program will now read something like Fig 6.

A very primitive search routine, which would search through a complete file for

Tim Love's

CRICKET

Dragon 32 — £8.95

"BETTER THAN THE REAL THING!" — Central TV

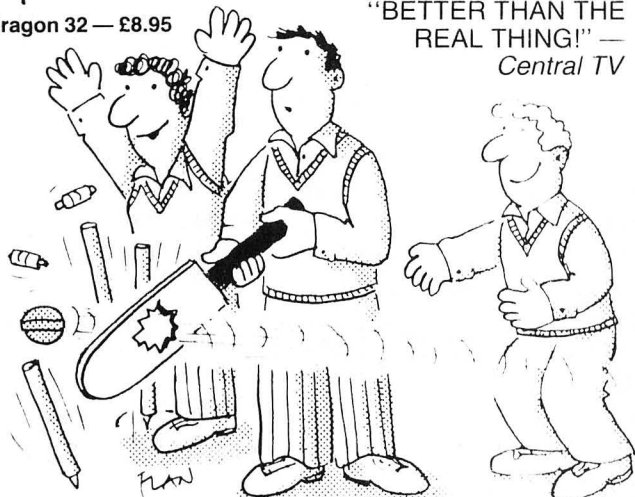

"INGENIOUS . . . BRILLIANT" — *Personal Computer Games*

"REMARKABLE . . . FANTASTIC DETAIL . . . GRAPHICS 100% . . . VALUE 100%" —

Home Computing Weekly

"Superb — Many other computer owners will wish they had bought a Dragon" — *IG*

"I would not hesitate to say that this is the best game I have" — *MB*

"Best of my 50 games" — *SF*

"Brilliant — I've been playing it for 2 weeks, and I still can hardly believe it's possible!" — *DV*

You have to see it to believe it! Bowling, batting and fielding under total joystick control, with batting and bowling action in BIG, ANIMATED GRAPHICS. Guaranteed to make a Spectrum owner as sick as a parrot! If you couldn't care less about cricket, you'll be hooked. If you're a fan, you'll be playing all night!

CHAMPIONS!

Take your team from the 4th Division to the European Cup! Features 4 divisions, promotion, relegation, goal highlights, transfers, injuries, suspensions, weekly results and league tables, reserve team, crowd trouble, and all the fun, drama and frustration of managing a league club. One of the most popular Dragon games of all time — over 18,000 satisfied customers — £6.95.



PHOTO-FINISH: Superb horse-race action. Terrific graphics, authentic race cards, odds based on actual form, REAL TIME races from 5f to 2 miles, 'Sporting Life' result cards with distances, times, etc, and an incredible photo-finish feature. 1-4 players. £7.95

All titles available for Tandy Color 32K

No need to wait! Check with your retailer, clip the coupon, or phone your Access/Visa number. Orders received before noon despatched same day by first-class post.

PEAKSOFT, 48 QUEEN STREET, BALDERTON, NEWARK, NOTTS. Tel: 0636 705230 (24-hour answering)

I enclose a cheque or PO, post me the following programs the day my order arrives:

I have a Dragon 32/64/Tandy (Please delete)

Name

Address

MONEYBOX PERSONAL ACCOUNTS PROGRAM FOR DRAGON 32/64

MONEYBOX is a new program for personal accounts. It can analyse your income and expenses, control your bank account, credit card, building society etc, forecast your bank balance, estimate your taxable income, and much more.

CASSETTE VERSION: features large capacity, user-defined periods, password protection, automatic date-sorting, user-defined account names, multiple reports to screen or printer, friendly operation and comprehensive instructions.

CASSETTE VERSION price £9.99

DRAGONDOS DISK VERSION: prints 42 by 24 legible characters on Hi-Res screen, with true lower-case, £-sign etc. All the features of the cassette version PLUS:

- ★ Fast, easy direct access filing
- ★ Files can be as big as the disk
- ★ More accounts — up to 80
- ★ Monthly Budgeting facility
- ★ Option to have VAT analysis, for business use

"presents itself as a powerful and versatile package" — *"Home Computing Weekly"*

"an easy to use program that builds in a range of powerful facilities" — *"Which Micro"*

DISK VERSION price £14.99

Cheques/POs/Further details/Dealer enquiries to:

HARRIS MICRO SOFTWARE
49 Alexandra Road, Hounslow, Middlesex TW3 4HP
Tel: (01) 570 8335

MAKE THE MOST OF YOUR DRAGON 32

Two great books to help you tap the power of your Dragon 32.

MAKING THE MOST OF YOUR DRAGON, by Clive Gifford, leads you through programming the Dragon from first principles, and includes more than 150 complete programs, including major arcade games. £5.95.

DYNAMIC GAMES FOR THE DRAGON 32 — Tim Hartnell and Robert Young. Thirty magnificent games for the Dragon are lurking in this 180 page book, to make your computer behave just as you hoped it would when you bought it. Programs include MAGIC CASTLE, SNARK ATTACK, SPACE RESCUE, REVERSI/OTHELLO, CHECKERS and CUBIK'S RUBE. Just £4.95.



Interface Publications, Dept. DU, 9-11 Kensington High St. London W8 5NP.
I enclose £ Please send me the books indicated.

- Dynamic Games for the Dragon 32
 Making the most of your Dragon.

Name

Address

the occurrence of a specified string, and store the results of this search in a temporary file, is contained in Fig 7.

Lines 3060 and 3070 mean that if the CT flag is set to 1, or if the last record in the current file is "zzzzz" (the end-of-tape marker), then the search will be terminated after the current file in memory has been searched. Otherwise, the computer will automatically load a further file from tape, search it, and store the results of the search in T\$. Lines 3080, 3090, and 3100 blank the array without destroying the contents of the variables, call the LOAD subroutine, and start the SEARCH routine once more on the new file just loaded.

Automatic scanning

If you want to simplify the process, or make the scanning of multiple files automatic, simply omit lines 3005, 3006 and 3060.

Assuming that the files to be searched are stored one after the other on a single tape, then the computer will get on with the job of searching without needing any attention till the search has been completed. The process may be time-consuming, but as it is automatic, you can busy yourself at other pursuits (or trying to work out where to get the money to buy a disk drive, and make such expedients as this unnecessary) until the search has been finished. Possibilities here would be to make the computer set off a repeated beep when the search is finished to draw your attention to it, or have the search output its results to the printer rather than

```

3000 REM *** SEARCH SUBROUTINE ***
3005 CLS: INPUT "SEARCH MULTIPLE FILES (Y/N)"; S$
3006 IF S$="Y" THEN CT=0 ELSE CT=1
3010 INPUT "TYPE IN WORD TO BE SEARCHED FOR"; W$
3020 T=0
3030 FOR A=1 TO N
3040 IF INSTR(D$(A),W$)<>0 THEN T=T+1: T$(T)=D$(A)
3050 NEXT A
3060 IF CT=1 THEN 3500
3070 IF D$(N)="ZZZZ" THEN 3500
3080 FOR A=1 TO N : D$(A)="": NEXT A: N=1
3090 GOSUB 1210
3100 GOTO 3030
3500 PRINT "SEARCH COMPLETE"
3510 RETURN
  
```

Fig 7

storing them in a temporary array in the computer memory.

With these various fairly simple routines implemented as part of your database program, this program will now be able to deal with a much greater amount of material, both in terms of storing this material and processing it. The examples given in this article are, obviously, as close to the bare bones as can be, but this is no reason why the same techniques — of appending files, splitting files, merging separate files, and searching through a multiple set of files on tape, can't be incorporated into the routines of much more sophisticated database programs.

The most difficult technique to imple-

ment is probably the routine to search through a series of files, but even this is fairly straightforward if you recognise what is being done — rather than terminating the search when the file in memory has been examined, a fresh file is loaded and the search routine is simply rerun on this new file. The price paid for using the cassette in this fashion, as if it were a sequential disk-drive, is not so much the programming involved, since the Dragon cassette routines are very much the same as certain disk routines, but the time it takes to access data. However, even this is partly compensated for since such access is automatic, and the computer can be left to attend to this by itself. ■

COMPUTERWARE

Present:

QUALITY SOFTWARE..... FOR THE DRAGON 32/64 AT BARGAIN PRICES!!

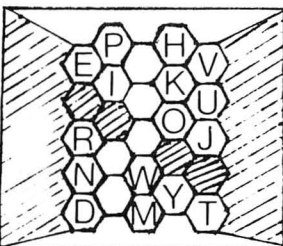
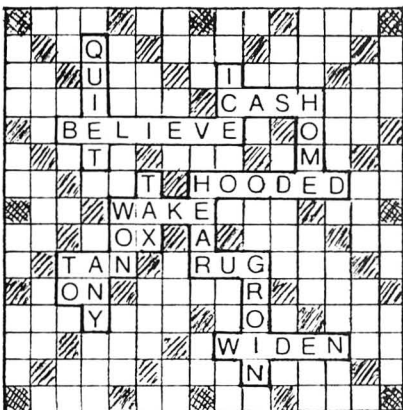

BLOCKBUSTER QUIZ

All the fun of the T.V. game adapted for 2 players. The game contains 500 questions covering a wide range of topics and varying in difficulty from easy to hard. Colourful, high resolution graphics are used to display the board, from which a player makes his letter choices and plots his winning path!

Only £5.50

LINKWORD

The game is for 2 to 4 players, the object being to score points by forming words on the board using only the letters randomly provided in your personalised 'rack'. The computer automatically calculates all scores, for both direct and indirect word formations, including double and triple word scores, 50 bonus etc. Full cursor control is provided so that letters may be easily placed anywhere on the board. The game features bright, colourful graphics, with facilities for correcting mistaken spelling or exchanging 'difficult' letters from your rack.

A Bargain Game at £5.50

Also: THE PUZZLER £3.50

CONNECT 4 (New Edition) £3.50

"USEFUL PEEKS & POKES"

The booklet describing how to disable BREAK, LIST, CSAVE, etc, etc, £1 post paid or free on request with all orders over £3

All prices include postage.

Cheque/POs payable to.

COMPUTERWARE

PO Box 318, Stoke-on-Trent, ST6 6UX

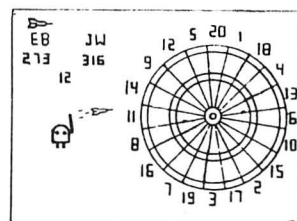

DARTS

An entirely original idea is used to produce a near approximation to the actual game. This fast game is for 2 players, and keyboard skill is needed to aim and fire the darts so that they hit any chosen part of the board. (YES even 180 may be achieved!!). The personalised scoreboards are continually up-dated by the computer, and standard rules apply, including the requirement of having to finish each game with a 'double' or 'bulls-eye'!

Only £5.50

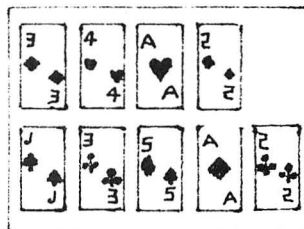

PONTOON

Full-colour high-resolution graphics. Ace counts 1 or 11 and special combination of 3 x 7's, 6, 7, 8 etc taken into account.

£3.50

Task Master

John Nash looks at some of the mysteries of the interrupt routine

MULTI-TASKING IS common on larger computers and refers to the operation of two or more procedures or programs at the 'same' time. Actually, the programs are interleaved so that, for example, the processor can update the video display while waiting for the operator to press the next key. One way of achieving this is by using interrupts.

Interrupts are signals sent to the processor, for example a peripheral is ready to donate or accept data. They cause the processor to stack enough information to remember where it was working, then jump to the interrupt service routine. When the service routine is finished, the processor can return to its previous task. The effect is rather like being called to dinner while you are reading your programmer's manual: you mark the place, then go to

dinner (service the interrupt). Afterwards, you carry on from the place you marked.

How does this apply to the Dragon? You may have noticed that the Dragon becomes totally unresponsive while printing programs or data on to paper. This is because the processor waits in a loop, constantly checking a flag for printer 'not busy'. As soon as the flag is clear, the next character is sent to the printer (to see how this works, inspect your ROM contents from \$BCF5 to \$BD08). This loop wastes a lot of time, as the printer is very slow compared with the processor.

There is an alternative method that can be used — the printer has an acknowledge 'ACK' line which is connected to the FIRO (fast interrupt) input, and can be used from machine code. The Dragon operating system does not use it. Two examples of

programs using this interrupt are described below.

1) A Basic program lister (Fig 1), which first copies an expanded (ie de-tokenised) version of the listing into upper memory. This is necessary to isolate the Basic program (and especially current line buffer) from the listing so that you can actually do something useful while the program is listing. You will find that you can now use the Basic system to edit, calculate or even program while the printer is working. There is a limit on program length of about 8K bytes, but you could fit in a longer program by doing a PCLEAR N operation with N<4. The program will alert you if the expanded version is too long to fit into the top half of memory.

```

00090 *BASLIST: BASIC LISTING WITH
00100 *INTERRUPTED PRINTING ON THE DRAGON
3F00 0010 00110 ORG $3F00
0019 00120 BASBEG EQU $19 /START OF BASIC PROG.
001B 00130 VARBEG EQU $1B /START OF VARS
7FFF 00140 MEMEND EQU $7FFF /$7FFF FOR DELTA DISK SYSTEM USE
00E6 00150 PRIEND EQU $E6 /TEMP. STORE
02DD 00160 BUFFER EQU $2DD /USED BY LINE EXPAND
BA5F 00170 CLS EQU $BA5F
957A 00180 PRINO EQU $957A /PRINTS NUMBER ON SCREEN
8F08 00190 LINEXP EQU $8F08 /LINE EXPAND
BCF5 00200 CHPRIN EQU $BCF5 /LINE PRINTER
800C 00210 SCREEN EQU $800C
3F00 00220 NEXTLI RMB 2 /NEXT LINE START
3F02 00230 POSITN RMB 2 /USED BY INT. HANDLER
3F04 1A 10 00240 START ORCC $S10 /IRQ OFF
3F06 9E 1B 00250 LDX VARBEG
3F08 8C 3EPE 00260 CMPX $S3EPE
3F0B 1024 0095 00270 LBHS ERROR /TOO LONG
3F0F 9E 19 00280 LDX BASBEG
3F11 108E 3FD3 00290 LDY $STORE
3F15 86 0D 00300 LDA #13
3F17 A7 A0 00310 STA ,Y+ /C.R.
3F19 EC 81 00320 LINE LDD ,X++
3F1B FD 3F00 00330 STD NEXTLI
3F1E 34 30 00340 PSHS X,Y
3F20 4F 00350 CLRA
3F21 BD BA5F 00360 JSR CLS
3F24 35 30 00370 PULS X,Y
3F26 EC 84 00380 LDD ,X
3F28 1E 12 00390 EXG X,Y
3F2A 34 30 00400 PSHS X,Y
3F2C BD 957A 00410 JSR PRINO /PUT NUMBER ON SCREEN
3F2F 35 20 00420 PULS Y
3F31 BE 0400 00430 LDX $S400
3F34 A6 80 00440 LOOP1 LDA ,X+
3F36 80 40 00450 SUBA $S400 /CORRECT & STORE IT
3F38 A7 A0 00460 STA ,Y+
3F3A 8C 0404 00470 CMPX $S404
3F3D 23 F5 00480 BLS LOOP1
3F3F 86 20 00490 LDA #32 /SPACE
3F41 A7 A0 00500 STA ,Y+
3F43 35 10 00510 PULS X
3F45 30 1E 00520 LEAX -2,X
3F47 34 30 00530 PSHS X,Y
3F49 BD 8F08 00540 JSR LINEXP /EXPAND LINE
3F4C 35 30 00550 PULS X,Y
3F4E 8E 02DD 00560 LDX $BUFFER
3F51 A6 80 00570 LDA ,X+
3F53 27 04 00580 BEQ LINDON
3F55 A7 A0 00590 STA ,Y+ /COPY BUFFER
3F57 20 F8 00600 BRA LOOP2
3F59 BE 3F00 00610 LINDON LDX NEXTLI
3F5C A6 84 00620 LDA ,X
3F5E 27 07 00630 BEQ OUT /SECOND ZERO = FINISHED
3F60 86 0D 00640 LDA #13
3F62 A7 A0 00650 STA ,Y+
3F64 16 FFB2 00660 LBRA LINE
3F67 86 0D 00670 OUT LDA #13
3F69 A7 A0 00680 STA ,Y+
3F6B A7 A4 00690 STA ,Y
3F6D 108C 7FFF 00700 CMPY $MEMEND
3F71 22 31 00710 BHI ERROR /OVERSHOT!
3F73 109F E6 00720 STY PRIEND
3F76 CC 3FD3 00730 LDD $STORE
3F79 FD 3F02 00740 STD POSITN /GET READY TO PRINT
3F7C CC 3F8D 00750 *INTERRUPT ENABLE
3F7F FD 0110 00760 LDD $INSTAR
3F82 86 35 00770 STD $110 /VECTOR
3F84 B7 FF21 00780 LDA $S35
3F87 86 0D 00790 STA $FF21 /ENABLE FIRO
3F89 BD BCF5 00800 LDA #13
3F8C 39 00810 JSR CHPRIN /START PRINTER TO GENERATE 'ACK'
3F8D 39 00820 RTS /RETURN FROM S/R WITH INTERRUPTS
3F8B 34 16 00830 *INTERRUPT HANDLER
3F8F B6 FF20 00840 INSTAR PSHS D,X
3F92 HE 3F02 00850 LDX $FF20 /CLEAR FLAG
3F95 A6 80 00860 LDA ,X+
3F97 BF 3F02 00870 STX POSITN
3F9A 9C E6 00880 CMPX PRIEND
3F9C 22 18 00890 BHI INACT1 /I.E. FINISHED
3F9E BD BCF5 00900 JSR CHPRIN
3FA1 35 16 00910 PULS D,X
3FA3 3B 00920 INACT2 RTI
3FA4 8E 3FC2 00930 ERROR LDA $MESSAG
3FA7 A6 80 00940 LOOP3 LDA ,X+
3FA9 81 25 00950 CMPA #'$
3FAB 27 12 00960 BEQ ERRRET
3FAD 34 10 00970 PSHS X
3FAF BD 800C 00980 JSR SCREEN
3FB2 35 10 00990 PULS X
3FB4 20 F1 01000 BRA LOOP3
3FB6 86 34 01010 INACT1 LDA $S34
3FB8 B7 FF21 01020 STA $FF21
3FBB 1C EF 01030 ANDCC $SEF /IRQ ON
3FBD 20 E2 01040 BRA INACT2
3FBF 1C EF 01050 ERRRET ANDCC $SEF
3FC1 39 01060 RTS
3FC2 50 01070 PCC /PROGRAM TOO LONG*/
52 01080 MESSAG
4F 52
4F 47
52 41
4D 40
20 20
54 4F
4F 4F
4C 4E
25 47
3FD3 01090 STORE EQU
0000 01100 END
00000 TOTAL ERRORS

```

Fig 1

2) This is an interrupted printing routine (Fig 2) which can be used with a word processor. It assumes that the text will start at address 135000 decimal, and the following codes are used:

```

CHRS(91) NEW LINE.
CHRS(93) NEW PARAGRAPH.
CHR(94) DOUBLE SIZE.
CHRS(95) SINGLE SIZE.

```

These could be altered to suit text from any word processor. Both routines are intended as illustra-

tions of the interrupt control method, to encourage you to experiment. Please use any parts of them that seem useful in your own programs.

To load these programs, first clear the memory space:

```

CLEAR 200,&H3EFF for BASLIST
CLEAR 200,&H2EDF for WPINT.

```

Next load the hex dump into DATA statements (one program at a time). The left hand column holds the addresses while, the remaining 16 columns add the

data (instructions). Do not, therefore, load the left hand column. Your first DATA line for BASLIST should start:

```
10 DATA 1A,10,9E,1B,8C etc.
```

When you have loaded all the DATA into lines 10 onwards, enter the following:

```

5 INPUT "START,FINISH";S,F
6 FOR N=S TO F
7 READ A$:POKEN,VAL("&H"+A$):NEXT N
8 END

```

and RUN it. START is &H3F04 and FIN-

ISH is &H3FD3 for BASLIST. START is &H2EE0 for WPRINT (extra bytes in last line of dump not needed).

When the program has finished running, immediately save it on tape with:
CSAVEM"BASLIST",S,F,1.

Do the same for WPINT. In future, you will only need to CLEAR the memory space, and CLOADM the programs to use them. They are used by typing EXEC &H3F04 instead of LLIST and EXEC &H2EE0 to print out the word processor

file.

NOTE: The IRQ is intentionally disabled during the running of these programs, so TIMER, PLAY etc will not work concurrently.

```

00090 *WPINT
00100 *WORD PROCESSOR INTERRUPTED PRINTING FOR DRAGON
2E00 00110 ORG 12000
2E01 1A 10 00115 ORCC #510
2E02 8E 34BC 00120 START LDX #13500 /IRQ OFF
2E03 BF 2F5C 00130 STX POSN /TEXT START
2E04 8E 2EFA 00140 LDX #INSTAR
2E05 BF 0110 00150 STX $110 /VECTOR
2E06 86 35 00160 LDA #S35
2E07 B7 FF21 00170 STA SFF21 /ENABLE INTERRUPT
2E08 86 0D 00180 LDA #13 /C.R.
2E09 C6 01 00190 LDB #1
2E0A 8D 4F 00200 BSR PRINT /START UP PRINTER
2E0B 39 00210 RTS
00220 *INTERRUPT ROUTINE
2E0C B6 FF20 00240 INSTAR LDA SFF20 /CLEAR FLAG
2E0D 34 10 00250 PSHS X
2E0E BE 2F5C 00260 LDX POSN
2E0F A6 80 00270 LDA ,X+
2E10 BF 2F5C 00280 STX POSN
2E11 9C 2F5E 00290 CMPX TEXEND
2E12 24 47 00300 BHS INTOPF
2E13 81 5B 00310 CMPA #91
2E14 27 13 00320 BEQ NL /NEW LINE
2E15 81 5D 00330 CMPA #93
2E16 27 22 00340 BEQ PARA /PARAGRAPH
2E17 81 5E 00350 CMPA #94
2E18 27 12 00360 BEQ LARGE /DOUBLE SIZE
2E19 81 5F 00370 CMPA #95
2E20 27 14 00380 BEQ SMALL /SINGLE
2E21 C6 01 00390 LDB #1
2E22 8D 28 00400 COMMON BSR PRINT
2E23 35 10 00420 FINISH PULS X
00000 TOTAL ERRORS
00000 00000 00730 END

```

Fig 2

HEX. DUMP FOR BASLIST

```

3F04 1A 10 9E 1B 8C 3E FE 10 24 0 95 9E 19 10 8E 3F
3F14 D3 86 D A7 A0 EC 81 FD 3F 0 34 30 4F BD BA 5F
3F24 35 30 EC 84 1E 12 34 30 BD 95 7A 35 20 8E 4 0
3F34 A6 80 80 40 A7 A0 8C 4 4 23 F5 86 20 A7 A0 35
3F44 10 30 1E 34 30 BD 8F 8 35 30 8E 2 DD A6 80 27
3F54 4 A7 A0 20 F8 BE 3F 0 A6 84 27 7 86 D A7 A0
3F64 16 FF B2 86 D A7 A0 A7 A4 10 8C 7F FF 22 31 10
3F74 9F E6 CC 3F D3 FD 3F 2 CC 3F 8D FD 1 10 86 35
3F84 B7 FF 21 86 D BD BC F5 39 34 16 B6 FF 20 BE 3F
3F94 2 A6 80 BF 3F 2 9C E6 22 18 BD BC F5 35 16 3B
3FA4 8E 3F C2 A6 80 81 25 27 12 34 10 BD 80 C 35 10
3FB4 20 F1 86 34 B7 FF 21 1C EF 20 E2 1C EF 39 50 52
3FC4 4F 47 52 41 4D 20 54 4F 4F 20 4C 4F 4E 47 25 4

```

HEX. DUMP FOR WPINT-

INTERRUPTED TEXT PRINTING FOR WORD PROCESSOR

```

2E00 1A 10 8E 34 BC BF 2F 5C 8E 2E FA BF 1 10 86 35
2E0F B7 FF 21 86 D C6 1 8D 4F 39 B6 FF 20 34 10 BE
2F00 2F 5C A6 80 BF 2F 5C BC 2F 5E 24 47 81 5B 27 13
2F10 81 5D 27 22 81 5E 27 12 81 5F 27 14 C6 1 8D 28
2F20 35 10 3B 86 D F6 2F 60 20 F4 86 E C6 1 20 EE
2F30 86 14 C6 1 20 E8 86 D F6 2F 60 8D B F6 2F 60
2F40 8D 6 86 20 C6 5 20 D6 34 15 BD 80 F 35 15 5A
2F50 26 F6 39 86 34 B7 FF 21 1C EF 20 C4 0 0 0 0
2F60 F1 D1 D5 D5 F5 F5 F5 F5 F5 F5 F5 F5 F5 F5 F5

```

Datapen

A QUALITY LIGHTPEN

for the DRAGON 32 microcomputer

Datapen

£25

inclusive of VAT, P&P. Two different drawing programs provided free with each lightpen. "SKETCH" and "SHAPE-CREATE". SKETCH is a superb high resolution colour drawing program allowing both precise drawing and freehand sketching, painting etc. SHAPE-CREATE is a high resolution library shape drawing program.

SUPERIOR PROGRAMS

- * Tape storage of your work
- * Good documentation
- * User routines provided on tape and on printout

Also available for:- VIC-20, CBM-64 or BBC B. Please state your micro when ordering.

Send cheque or P.O. for £25 to:-

D.U.3 Datapen Microtechnology Limited,
Kingsclere Road, Overton, Hants. RG25 3JB

Or send S.A.E. for details. Now available from good computer shops.

SUPERIOR PERFORMANCE

- * Insensitive to ambient lighting
- * Responds to different colours
- * Program accessible LED lamp readout
- * Switch for program control

"It differs from all other lightpens available for the Dragon in that it is a far more sophisticated beast... This program (Sketch)... clearly demonstrates the superiority of the Datapen"

Popular computing Weekly, Dec. 15th

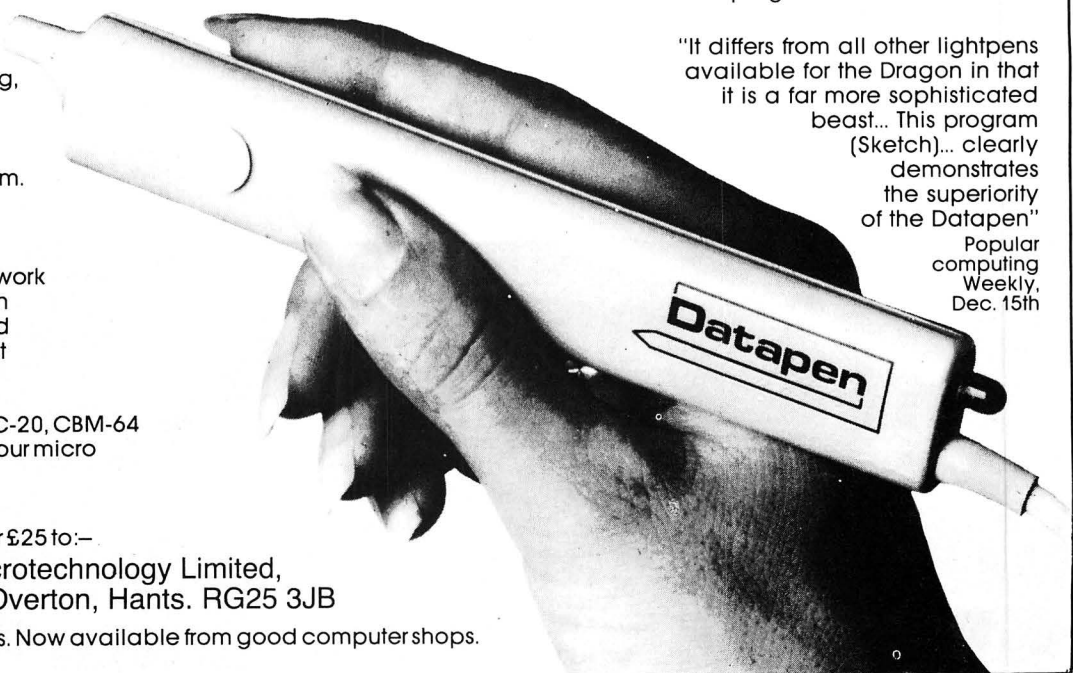

DRAGON OPEN FILE

Send us your Dragon programs, beginning with a general description and then explaining how the program is constructed. Take care that the listings are all bug free, enclosing a cassette and, if possible, a printout. We pay £6 for each original bug-free program published, double for the program of the month. If you have any problems with the listings, please send your queries to the appropriate author, *Dragon User*, 12-13 Little Newport Street, London WC2H 7PP.

Brick

From *Iolo ap Gwynn in Aberystwyth*
BRICK is yet another version of an old

favourite, which seems to originate in a certain orchard. In this one the bat is mobile in two directions and a degree of skill is required in order to master this game. A word of warning though, it can be mildly addictive. Apart from asking for another game, all control is by means of the right-hand joystick and its fire button.

All of the game is played between lines

250 and 460. Directions of travel after a rebound is determined by a set of sub-routines, lines 580-630, which are called according to the flag set in line 270.

Should you stop the game by pressing the "BREAK" key then be sure to press the RESET button before you attempt to load or save from tape because the I/O is upset by the higher speed set in line 10.

```

10 POKE 84#FD6,0: SET HIGH SPEED
20 CLS: RE=0
30 PRINT@ (832)+10, "BRICK - MALL
40 PRINT@ (832)+5, "TO PLAY THIS GAME YOU WILL NEED TO FLIP
   IN A JOYSTICK. CONTROL INTO THE
   RH SOCKET"
50 PRINT@ (832)+5, "THE MOVEMENT OF THE BAT IS
   CONTROLLED BY THE LEFT JOY
   MOVEMENT OF THE JOYSTICK"
60 PRINT@ (15432), "© IAP GWYN: 1983
70 FOR I=0 TO 10000: NEXT I
80 CLS: HD=JOYSTK(0): BF=(INT(JOYSTK(1)/4)+32)*INT(D
   2): DU=JOYSTK(2)
90 PRINT@ (832)+3, "PRESS BUTTON TO START GAME"
100 IF PEEK(8528)=128 OR PEEK(8528)=154 THEN GOSUB 400
   ELSE GOTO 90
110 BE=0
120 * STAFF BALL
130 R=RND(1)/D1=0
140 PE=(8132)/(22+R)+3*PND(0)
150 PDE=1024+PC,128
160 GOSUB 250
170 CLS
180 PRINT@ (832)+5, "YOUR SCORE WAS: 150
190 IF SC RE THEN PRINT@ (832)+5, "THIS IS A RECORD"
   : RE=SC: FOR I=0 TO 20: SOUND 100,2: NEXT I
200 PRINT@ (1032)+5, "ANOTHER GAME Y/N: "
210 Q=INKEY: IF Q="N" THEN 100
220 IF Q="Y" THEN 30
230 POKE 84#FD6,0: RESET SPEED TO NORMAL
240 END
250 F=1024+PC:1024 OR 1024+PC 1535 THEN RETURN ELSE
   DU=JOYSTK(0): BN=(INT(JOYSTK(1)/4)+32)*INT(D
   U/2): DU=JOYSTK(2): DU=JOYSTK(3)
260 POKE 1024+BF,143: BF=BN: PDE=1024+BF,149
270 ON FL GOSUB 580,590,600,610,620,630
280 IF DT=0 THEN 390
290 IF PEEF(1024+PND)+201 THEN SC=SC+1: SOUND 100,2: GOTO 360
300 IF PND AND PND 31 THEN FL=3: GOTO 350
310 IF PND 15432 AND PND(15432)+1 THEN FL=1: GOTO 300
320 FOR X=51 TO 51: STEP 32
330 IF PND X THEN 170
340 NEXT X
350 PDE=1024+PC,143: PC=PN: PDE=1024+PC,128: GOTO 250
360 PDE=1024+PC,143: PC=PN: PDE=1024+PC,128
370 FL=3+RND(5)/D1=0
380 GOTO 250
390 IF PEEF(1024+PND)+201 THEN SC=SC+1: SOUND 100,2: GOTO 480
400 IF PND AND PND 31 THEN FL=4: GOTO 450
410 IF PND 15432 AND PND(15432)+1 THEN FL=2: GOTO 450
420 IF PEEF(1024+PND)+149 THEN FL=7: DT=1: SOUND 80,2: GOTO 500
430 FOR Y=0 TO 15
440 IF PND Y:32 THEN RETURN ELSE NEXT Y
450 PDE=1024+PC,143: PC=PN: PDE=1024+PC,128: GOTO 250
460 PDE=1024+PC,143: PC=PN: PDE=1024+PC,128: GOTO 400
470 * DRAW FIELD
480 CLS
490 FOR I=0 TO 15
500 POKE 1024+(1832)+23,201
510 POKE 1024+(1832)+25,201
520 POKE 1024+(1832)+27,201
530 POKE 1024+(1832)+29,201
540 POKE 1024+(1832)+31,201
550 NEXT I
560 RETURN
570 * DIRECTIONS
580 PN=PC-31: RETURN
590 PN=PC-1: RETURN
600 PN=PC+33: RETURN
610 PN=PC+31: RETURN
620 PN=PC-1: RETURN
630 PN=PC+33: RETURN

```

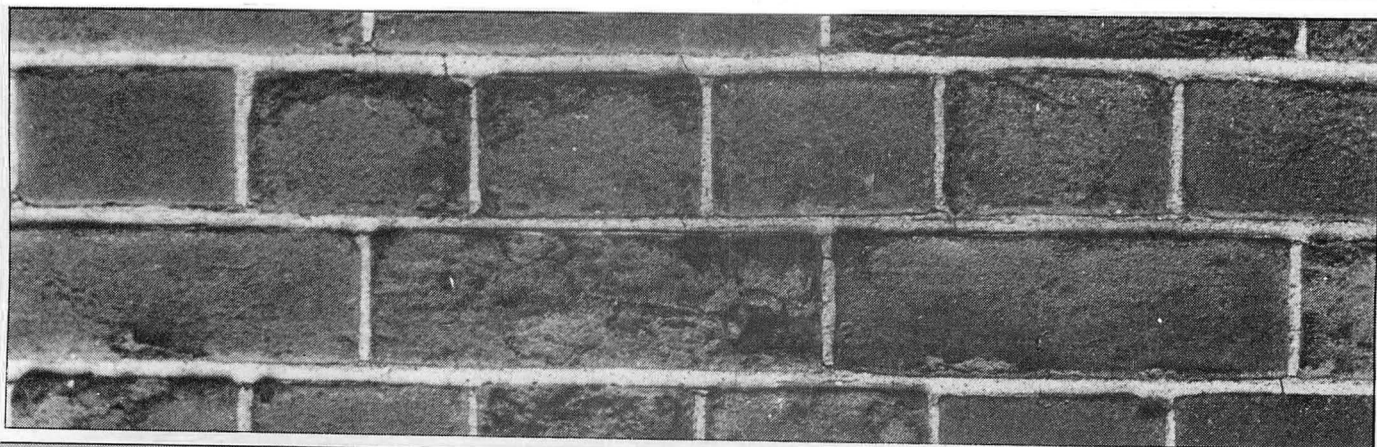

Mantukan Pyramid

From A. Daniel in *Sevenoaks*

THE MANTUKAN PYRAMID is a game which sets an interesting puzzle to determine how to achieve the highest possible score. Try the game first at about level 3 to get the idea and then try some of the deeper levels (for example 20 or 30).

The score is made up of treasure points, a screen bonus and a time bonus and you have to contend with a man-eating Mantukan bat and a limited supply of fresh air.

There are rem lines, instructions and various methods of play as well as a tape saving routine, but to make it all as clear as possible here are a few extra notes.

The essential lines of the program are 30-1180 followed by 1340-1770 which determine the type of game and the final score. The remainder are sound effects, title page and detailed instructions.

The Pyramid scoring sequence may be tested on its own by temporarily writing GOTO 700 instead of the rem in line 80.

The variable MT (line 150) gives the amount of air available. BB and B relate to the level of play. Line 560 determines the number of treasure points you can pick up and this is related to the level of play. It takes some working out but is meant to be subtle. The time bonus is created by MC (line 1570) and the formula in line 1670.

You can easily get a negative time bonus but if you don't like this then increase the value of MC.

You may go over a treasure square several times but as you leave a black trail behind you, you may lose track of where you are and get eaten by the spider. The movements of the spider are deliberately made fairly predictable to make avoiding it a matter of skill and not luck.

It would, I think, take another computer program to work out which level of play is likely to produce the highest scores, bearing in mind that you must reach the summit of the pyramid to earn the bonuses so the best thing you can do is to start playing the game.

To save your typing on tape turn on the recorder and type RUN10000. You can save up to four times.

```

10 GOSUB1850: ' TITLE SEQUENCE - THE MAN
TUKAN PYRAMID - BY A. DANIEL (13/12/84)
20 ' INTIAL VALUES
30 DIMSF(10),SG(10),HT(512)
40 FOR F=1 TO 8
50 READ SF(F),SG(F)
80 NEXT F
70 SP=480
80 ' TO TEST SCORE PYRAMID TYPE THIS LIN
E AS GOTO700
90 GOSUB1190
100 ' NEW GAME SEQUENCE
110 GOSUB1340
120 TIMER=0
130 ' MAIN SEQUENCE
140 CLS:X=511: SD=0: TT=500: N1=100
150 MT=6000/B: IF MT>555 THEN MT=555
160 K1=RND(8)
170 K2=RND(8): IF K2=K1 THEN 170
180 K3=RND(8): IF K3=K2 OR K3=K1 THEN 18
0
190 FOR A=1 TO 510
200 F=RND(B): IF F>3 THEN F=3
210 IF F=1 THEN K4=K1*16
220 IF F=2 THEN K4=K2*16
230 IF F=3 THEN K4=K3*16
240 HT(A)=F
250 PRINT@A,CHR$(127+K4);
260 NEXT
270 ' PLAY SEQUENCE
280 POKE1024+X,128
290 MT=MT-1
300 PRINT@480,INT(MT);
310 IF MT<0 THEN CLS: PRINT:PRINT:PRINT"
THE AIR HAS BECOME POISONOUS": PRINT"STA
RT AGAIN": FOR J=1 TO 5000: NEXT: GOTO14
0
320 IF HT(X)=3 THEN SD=SD-1
330 IF HT(X)=2 THEN GOSUB550
340 IF X=511 THEN SD=SD-1
350 IF PEEK(344)=223 THEN X=X+1: GOSUB51
0: BH=0
360 IF PEEK(343)=223 THEN X=X-1: GOSUB51
0: BH=0
370 IF PEEK(342)=223 THEN X=X+32: GOSUB5
10: BH=0
380 IF PEEK(341)=223 THEN X=X-32: GOSUB5
10: BH=0
390 ' THE MANTUKAN BAT SEQUENCE
400 POKE1024+Y,W: Y=Y-RND(20): IF Y<1 TH
EN Y=510
410 W=PEEK(1024+Y): PRINT@Y,"W";
420 IF X=0 THEN PRINT@X,"*": GOTO430 EI
SE 440
430 IF ZX=1 THEN 590 ELSE 650
440 IF X=Y THEN CLS: PRINT@99,"YOU ARE
IN THE MANTUKAN BAT'S BELLY, SO YOU HAD
BETTER START AGAIN":PLAY"ET4EFT2ET4GF#F
#EED#T2E":GOTO 140:FI SE 460
450 PLAY"ET4P60EP60T8ET2P60ET4GF#F#EED#T
2E"
460 N=SD+N1: IF N<2 THEN N1=N1+100: GOTO
460
470 IF N>254 THEN N1=N1-100: GOTO460
480 IF BN<>N THEN 490 ELSE 270
490 SOUNDN,1: BN=N
500 GOTO270
510 ' POINT ADDING SEQUENCE
520 IF X<0 THEN X=X+32: GOTO520
530 IF X>511 THEN X=X-32: GOTO530
540 RETURN
550 BH=BH+1
560 IF BH>RND(20) THEN A=-1 ELSE A=RND(I
NT(B/10)+1)
570 SD=SD+A
580 RETURN
590 FOR X=0 TO 63 STEP2
600 FOR Y=0 TO 31 STEP2
610 IF POINT(X,Y)=K2 THEN CLS:PRINT:PRIN
T: PRINT"YOU CHEATED - THERE'S A TREASUR
E SQUARE LEFT SO GO BACK TO THE START
": FOR J=1 TO 5000: NEXT: GOTO140
620 NEXT Y
630 NEXT X
640 GOTO660
650 FOR GG=1 TO 1000: NEXT
660 GOSUB740
670 IF ZX=1 THEN ZX=0: GOTO100
680 FOR JJ=1 TO 2000: NEXT
690 GOSUB1480: GOTO140
700 ' SCORE TEST
710 SD=300
720 GOSUB740
730 SD=20: GOTO720
740 ' SCORING SEQUENCE
750 CLS3
760 FOR G=352 TO 511
770 POKE1024+G,159
780 NEXT
790 NX=78: PX=2
800 FOR LX=1 TO 14
810 FOR MX=NX TO (NX+PX)

```

Continued on page 31

SIMPLY

The best value for money software
you will ever buy for your
DRAGON 32...and that's not just our opinion...
9 superb full length games
on one cassette
for only **£3.95**

Dear Sir,
After purchasing your games cassette for my Dragon 32 I felt I had to write and say you are crazy! I have purchased many good games for my Dragon and have been pleased with them but your games tape is absolutely amazing value. I can honestly say that I would be happy to pay £3.95 for any one of these games, especially, Interplanetary Trader, Empire and Execution. They are extremely addictive.
I want to wish your company the very best with this cassette, it deserves to be a No. 1 seller.

Yours sincerely
Mr C Davis
W. Midlands

INTERPLANETARY TRADER

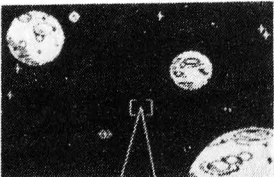

Pirate Attack! Just one of the many hazards encountered as you strive to become first ever GALACTIC MEGABILLIONAIRE! Success depends on ability to make lightning decisions, accurate forward planning. Should you brave the Meteor Storm to save precious time? Pay the outrageous protection demanded by Space Pirates? This massive 28K game provides compelling entertainment.

EXECUTION

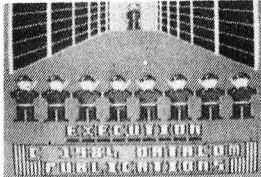

Are you cool, level headed? You need nerves of steel to play EXECUTION. Standing before the awesome firing squad you realise this is your last chance to receive a pardon, but time is fast running out. Features full high res moving graphics and sound. Hours of fun guaranteed in this massive 30K game.

WUMPUS MANSION

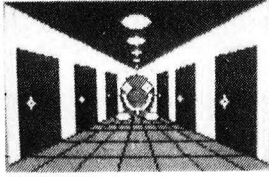

Only a crazy person would go near WUMPUS MANSION. You however, have ventured INSIDE it!!! Tempted by hoards of priceless treasures your mission is to raid the mansion and leave through the maze of tunnels. Will you outwit the dreaded WUMPI?? Can you avoid the time bombs?? Incredible fun!! Uses 29K.

WIPEOUT

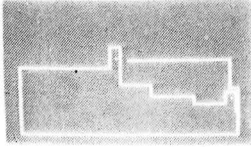

BE WARNED - THIS IS NOT EASY!! A challenging multilevel graphic game demanding fast, accurate reaction. It begins easily enough, but gets progressively more difficult. Features 4 colour high resolution graphics, sound, bonus points and high score.

HILO



Is it skill or luck? Can you turn your humble £50 stake into £1,000,000?? This simple yet highly compelling game supported by excellent colour graphics and brilliant sound effects. Over 20K of clever programming!

SNAIL PACE

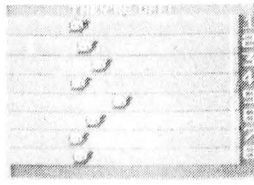

The excitement is almost unbearable as you watch 1-8 thoroughbred racing snails thrash it out on the racecourse!! Game features sensible odds and form guide to assist you. This superb piece of complex programming supported by magnificent graphics will ensure hours of excitement. A massive 26K!!

ATOM HUNT

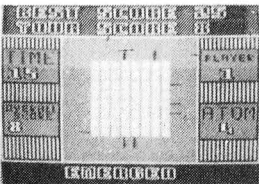

A superb feat of programming to make your brain ache and stretch your Dragon's memory chips to the absolute limit!! This game is played almost entirely in the 4 colour graphic modes and features a unique repeat game facility, individual ratings, and 1-4 players. Uses over 20K!!

AIR ASSAULT

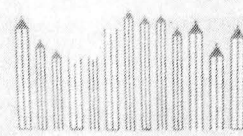

MAYDAY! MAYDAY! Your crippled helicopter is rapidly losing altitude and face certain death unless you blast a landing space in the deserted city of Kroywen. Total concentration and precision required if you intend to stay alive. A super addictive game supported with exceptional sound and graphics!!

EMPIRE



From a knight to a KING! Can you build up your empire in the face of stiff opposition? Will you keep your subjects happy and balance the economy. This is an exciting multilevel game of strategy for up to 4 players. Includes a save game facility.

DATAKOM PUBLICATIONS DEPT D3, 407F Hockley Centre, Birmingham B18 6NF Tel: 021 233 1800

9 SUPERB FULL LENGTH PROGRAMS ON ONE CASSETTE. AN INCREDIBLE 220K OF IMPRESSIVE PROGRAMMING, SPECTACULAR COLOUR GRAPHICS AND SOUND EFFECTS!!!

Send Cheques or P.O. to: DATAKOM PUBLICATIONS DEPT D3, 407F Hockley Centre, Birmingham

Name Quantity Required

Address Please find enclosed my cheque/P.O. for
..... £

..... Post Code Signed

Telephone: Cheque/P.O. No.

DEALER ENQUIRIES WELCOMED: TELEPHONE: 021 233 1800
DATAKOM PUBLICATIONS DEPT. D

```

820 POKE1024+MX,128
830 NEXT MX
840 NX=NX+31: PX=PX+2
850 NEXT LX
860 SD=SD+SQ
870 SN=480-INT(SD/32)*32:
880 IF SN=SP THEN SL=SP: GOTO920
890 IF SN<SP THEN SH=-32 ELSE SH=32
900 IF SH>0 THEN RE=0
910 FOR SL=SP TO SN STEP SH
920 SE=SL+15: IF SE>495 THEN SE=495
930 FOR F=1 TO 8
940 POKE1024+SE-SF(F),SG(F)
950 NEXT F
960 FOR GG=1 TO 200: NEXT
970 IF SL=SN THEN PRINT0,"SCORE ";SD;
980 IF SL<89 THEN PRINT0,"SCORE-";SD;:P
RINT0450,"WELL DONE! YOU HAVE REACHED";:
PRINT0492,"THE TOP";: FOR GG=1 TO 1000:
NEXT: GOTO 1620
990 IF (495-SD)>(SE+6) THEN GOSUB1130: G
OTO1100
1000 IF (495-SD)<(SE-6) THEN POKE990+SE,
220:POKE958+SE,210:SOUND89+RE,1
1010 FOR GG=1 TO 200: NEXT
1020 IF (495-SD)<(SE-12) THEN POKE1023+S
E,200: POKE1022+SE,204:SOUND101+RE,1
1030 FOR GG=1 TO 200: NEXT
1040 IF (495-SD)<(SE-18) THEN POKE993+SE
,220: POKE961+SE,209:SOUND97+RE,1
1050 FOR GG=1 TO 200: NEXT
1060 IF (495-SD)<(SE-24) THEN POKE1024+S
E,196: POKE1025+SE,204:SOUND105+RE,1
1070 FOR GG=1 TO 200: NEXT
1080 IF (495-SD)<(SE-31) THEN GOSUB1130
1090 IF SN=SP THEN SL110
1100 RE=RE+8:NEXT SL
1110 SP=SN: FOR GG=1 TO 500: NEXT
1120 SQ=SD:RETURN
1130 FOR SM=1 TO 4
1140 POKE1021+SE+SM,128
1150 POKE989+SE+SM,128
1160 POKE957+SE+SM,128
1170 NEXT
1180 RETURN
1190 ' INSTRUCTIONS
1200 CLS: PRINTTAB(5)"YOU ARE EXPLORING
INSIDE THE MIGHTY MYSTERY PYRAMID OF
MANTUKAN. IT IS DECORATED IN 3 MAGIC C
OLOURS, WHICH VARY FROM ";
1210 PRINT"LEVEL TO LEVEL. ONE COLOUR IS
CURSED BY THE ANCIENT KINGS (YOULOSE
POINTS); A 2ND COLOUR HAS THE PEACE OF
THE GODS (NO SCORE HERE); AND ON THE 3RD
COLOUR YOU ";
1220 PRINTTAB(0)"CAN COLLECT TREASURE -
BUT TAKE CARE, FOR THE CURSE MAY STILL
BREAK THROUGH IF YOU SPEND TOO LONG THE
RE."
1230 PRINT:PRINT:PRINT"PRESS ANY KEY TO
CONTINUE";
1240 IF INKEY$="" THEN 1240
1250 CLS: PRINTTAB(5)"EXPLORE USING ARRO
W KEYS FROM BOTTOM RIGHT TO TOP LEFT:
THEN SEE IF YOU HAVE REACHED THE TOP OF
THE PYRAMID. THE DEEPER THE LEVEL YOU S
TART AT THE MORE DIFFICULT IT IS TO SCOR
E POINTS AND REACH THE TOP."
1260 PRINTTAB(5)"BEWARE OF RUNNING OUT O
F AIR (AMOUNT IS PRINTED LOWER LEFT
). BEWARE ALSO THE DREADED MANTUKAN BAT
-IF HE LANDS ON YOUHE WILL SWALLOW YOU
WHOLE."
1270 PRINT:PRINT:PRINT"PRESS ANY KEY TO
CONTINUE";
1280 IF INKEY$="" THEN 1280
1290 CLS: PRINTTAB(4)"A RISING MUSICAL S
CALE MEANSYOU ARE GAINING POINTS AND VIC
E VERSA. WHEN YOU HAVE COLLECTED SUFFIC
IENT TREASURE POINTS YOU WILL REACH THE
PINNACLE OF THE PYRAMID."
1300 PRINTTAB(4)"THE CHALLENGE OF THE GA
ME ISTO FIND THE DEEPEST LEVEL OF EXP
LORATION FROM WHICH YOU CAN STILL REACH
THE TOP IN ONE OR MORE GOES."
1310 PRINT:PRINT:PRINT"PRESS ANY KEY TO
CONTINUE";
1320 IF INKEY$="" THEN 1320
1330 RETURN
1340 ' LEVELS OF PLAY
1350 CLS:PRINT"WHAT LEVEL WILL YOU EXPLO
RE"
1360 PRINT"0=EASY - 100=IMPOSSIBLE"
1370 INPUTBB
1380 CLS
1390 PRINT"DO YOU WANT TO PLAY ON:-"
1400 PRINT"A CONSTANT LEVEL":PRINT"ENTER
1"
1410 PRINT"A RANDOM LEVEL BETWEEN 0 AND
THELEVEL ENTERED ABOVE":PRINT"ENTER
2"
1420 PRINT"A PROGRESSIVELY EASIER LEVEL"
:PRINT"ENTER 3"
1430 PRINT"AN INCREASINGLY DIFFICULT LEV
EL":PRINT"ENTER 4"
1440 PRINT"(SCORE BONUS= 10*LEVEL OF PLA
Y -";
1450 PRINT"DEEPER LEVELS HAVE MORE VALUA
BLETREASURE BUT THERE IS MUCH LESS OF IT
)"
1460 INPUTAA: IF AA<1 OR AA>4 THEN 1460
1470 A1=1
1480 ON AA GOTO1490,1500,1510,1530
1490 B=BB+3: GOTO1550
1500 B=RND(BB+1)+3: GOTO1550
1510 IF BB<8 THEN BE=1 ELSE BE=5
1520 B=BB: BB=BB-BE: IF B<3 THEN B=3:BB=
3: GOTO1550
1530 IF BB>4 THEN BE=5 ELSE BE=1
1540 B=BB: BB=BB+BE: IF B<3 THEN B=3: BB
=4
1550 IF A1=1 THEN A1=0: GOTO 1560: ELSE
1590
1560 CLS: PRINT:PRINT:PRINT:PRINT" IF YO
U WANT A REALLY HARD GAME IN WHICH YOU H
AVE TO VISIT ALL THE TREASURE SQUARES T
O QUALIFY ENTER '1'": PRINT" EXTRA TIME
POINTS ALLOWED FOR THIS TYPE OF GAME"
1570 INPUT ZX: IF ZX=1 THEN MC=60000 ELS
E MC=40000
1580 AB$="GOOD LUCK": GOSUB1780
1590 TD=TD+B*10
1600 RETURN
1610 DATA0,197,1,202,31,221,32,223,33,22
3,34,222,64,194,65,193
1620 ' SCORE TOTALS
1630 SQ=SD

```

Continued on page 33

What's your best source of information on color computing?



Now you can improve your color computing skills... and it's easy to do. **HOT CoCo** gives you more *practical* information on the Dragon* than any other publication. Nearly 150 pages a month!

Every issue is packed with exciting new things for you to do. We won't waste your time with filler stories. You'll get instructive columns:

- **Elmer's Arcade**—enjoy old-fashioned arcade style games on *your* computer
- **The Basic Beat**—learn everything you need to program in Basic
- **The Educated Guest**—discover how to use your computer as a teaching tool
- **Doctor ASCII**—get answers to your technical questions
- **Graphically Speaking**—create eye-catching designs that add appeal to your programs

You also get a dozen easy-to-understand articles every month. Games... utilities... programming techniques... tutorials... graphics... education... hardware projects. They'll help you expand what you can do. And complete program listings show you how to use what you learn.

That's not all. **HOT CoCo** saves you money too:

- Candid reviews help you make every purchase a sound investment.
- Informative ads let you comparison-shop from home.
- New-product announcements tell you what's available *before* it reaches the stores.

With all this at your fingertips, your subscription could pay for itself with one wise purchase.

And **HOT CoCo** is risk-free. If you don't like your first issue, just write "cancel" across the invoice and return it to us. You won't owe a thing.

Subscribe to **HOT CoCo** today. Twelve big issues are only \$44.97 (US funds drawn on a US bank). Simply fill out the coupon below and return it right now to: **HOT CoCo Subscription Dept.**, PO Box 975, Farmingdale, NY 11737, USA.



* Dragon is a registered trademark of Dragon Data Ltd.

YES! Help me improve my computing skills. Send me 12 issues of **HOT CoCo** for \$44.97 (US). I understand that with payment enclosed or credit card order I will receive a **FREE** issue, making a total of 13 issues for \$44.97 (US).

Get a 13th issue **FREE** when you enclose payment or charge it on your Mastercard, Visa, or American Express.

CHECK/MO MC VISA AE

CARD # _____ EXP. DATE _____

SIGNATURE _____

NAME _____

ADDRESS _____

POST CODE _____ COUNTRY _____

HOT CoCo • 80 Pine Street • Peterborough, NH 03458 • USA

73DFDU

```

1640 IF A2=1 THEN TD=0
1650 CLS2: PRINT@96,"SCORE      "; SQ
1660 PRINT"SCREEN BONUS      ";TD
1670 MB=INT((MC-TIMER)/20)
1680 IF A2=1 THEN A2=0: MB=0
1690 PRINT"TIME BONUS      ";MB
1700 TT=SD+TD+MB
1710 PRINT"TOTAL      ";TT
1720 GOSUB1830
1730 PRINT:PRINT"PRESS CLEAR FOR ANOTHER
GAME"
1740 HA$=INKEY$: IF HA$="" THEN 1740
1750 IF HA$=CHR$(12) THEN 1760 ELSE 1740
1760 SQ=0: TD=0: MB=0: TT=0: ZZ=1: SP=48
0: RE=0
1770 RETURN
1780 ' ADDITIONAL INSTRUCTIONS
1790 CLS8:PRINT@32,"      SCREEN BONUS IS
WORTH MOST POINTS; THEN THERE IS A TIME
BONUS WHICH CAN COUNT AGAINST YOU
IF YOU SPEND TOO LONG. YOU CANNOT GET A
SCREEN BONUS UNLESS";
1800 PRINT"YOU REACH THE TOP OF THE PYRA
MID"
1810 '
1820 PRINT@298,AB$;
1830 PLAY"T8B04CD03B04C03ABGAF#T4GBT7DP6
T804CDECD03B04C03ABGT4F#AT7DP6T8EF#GDEF#
GEF#G#AEF#G#AG#AB04C03B04CDECO3AF#GDGBT4
G"
1840 RETURN
1850 A$="U6E2R2F2D6U4L6"
1860 D$="U8L1R5F1D6G1L5"

```

```

1870 E$="U8R5L5D4R4L4D4R5"
1880 H$="U8D4R6U4D8"
1890 I$="BR3R2L1U8R1L2"
1900 K$="U8D5E5G4F4"
1910 M$="U8F3E3D8"
1920 N$="U8D1F6D1U8"
1930 P$="U8R6D4L6"
1940 R$="U8R5F1D2G1L5R1D1F4"
1950 T$="BU8R6L3D8"
1960 U$="BU1U7BR6D7G1L4H1"
1970 Y$="BU8F3D5U5E3"
1980 PMODE3,1:SCREEN1,0:PCLS2
1990 DRAW"S15;C1;BM85,40;" +T$:DRAW"BM115
,40;" +H$:DRAW"BM145,40" +E$
2000 DRAW"BM25,80;" +M$:DRAW"BM55,80;" +A$
:DRAW"BM85,80;" +T$:DRAW"BM115,80;" +U$:DR
AW"BM145,80;" +K$:DRAW"BM175,80;" +A$:DRAW
"BM205,80;" +N$
2010 DRAW"S4;C4BM77,140;E50F50L100"
2020 PAINT(110,120),4,4
2030 DRAW"S15;C1;BM25,180;" +P$:DRAW"BM55
,180;" +Y$:DRAW"BM85,180;" +R$:DRAW"BM115,
180;" +A$:DRAW"BM150,180;" +M$:DRAW"BM175,
180;" +I$:DRAW"BM205,180;" +D$
2040 FOR U=1 TO 1000:NEXT
2050 RETURN
10000 FOR AH=1 TO 10000: NEXTAH
10010 FOR A2= 1 TO 4
10020 CLS3:PRINTAZ: CSAVE "PYRAMID"
10030 MOTOR ON:CLS4
10040 IF A2=4 THEN STOP
10050 FOR AJ=1 TO 3000: NEXTAJ
10060 NEXT A2

```

Wizard Software



TRACE CHASE

£4.95

A colourful 100% machine code game presented in high resolution graphics. Move your man around the lines of the grids but beware of the chasers unless you can 'STOP' them. Nine grids are provided. Number of lives, STOPS, and score are continuously displayed. One joystick required.

STARTING FRACTIONS

£5.95

A teaching program designed by teachers, for primary school children, which presents and teaches the concept of a fraction. There are four units contained in the program, the first three deal respectively with HALF, QUARTER and THIRD, the fourth unit deals with the concept of "Fractions of Numbers" consolidating the material learned in the first three units. After each unit there is a test to assess readiness to proceed with the next stage.

TIME PORT — The Staff of Life

£6.45

The second adult strategy adventure game in the Time Port series, containing a complex lexical and logic analyser that allows instructions to be input as sentences containing articles, nouns, verbs, adjectives etc. A game of logic and manipulation structured to exercise your powers of deduction, observation and association. Contains a game save facility.

COMPUTA FRUITA

£5.95

A de-luxe fruit machine simulation presented in colourful high resolution graphics featuring: 4 drums, Spin, Respin, Hold, Gamble, Collect, Nudge, Bounce, Blind, Cancel, Jackpot, Hi-Lo, Bonus, Roller, and Auto-Win. New drums manufactured for each game.

TIME PORT 1	£6.45	EVICTOR	£4.95	SMASM	£3.95
DRAGON STARTREK	£6.45	RED ALERT	£4.95	DISMON	£3.95
STRATEGY	£6.45	ALIENS +	£4.95	STARWORD	£2.95
DECATHLON	£5.95	CLOWNS	£3.95	TRIPLET	£2.95
TOUCHDOWN	£5.95	CRAZI PLUMBER	£3.95	SIRIUS IV	£2.95
		WIZARD	£2.95		

All prices inclusive, mail order, cheques or postal orders to:

**WIZARD SOFTWARE, DEPT. DU, PO BOX 23
DUNFERMLINE, FIFE KY11 5RW**

Send large SAE (7in x 5in) for full program catalogue.
Royalties paid for machine code DRAGON software.

R & P International

Programs for the Dragon 32/64

INSTANT GRAPH PLOTTER 1

Want to know more about the place of graphs in everyday life? Want a handy tool for instant display of many kinds of data for school, work or hobbies? Want a package to enter, display and manipulate all kinds of graph-style data for professional, technical or scientific use?

Whichever your need you will find that this program meets it
Up to six graphs continuously displayed on high-res screen

Input data and call up numerous functions and display aids by superbly clear graphics-text prompts

Cassette file storage and retrieval of data

Readily accessible Basic — adding your own functions easy

★ Comprehensive 28-page Manual provided free. From beginner to expert. Over two dozen examples

★ R & P will give advice on program use or modification to any user at any level of expertise. Free on request

... package is amply supported by ... manual, and half an hour spent with this, and using the excellent screen prompts, will make its use simplicity itself ... education value ...
Gordon Lee (Dragon User January 1985)

*** Awarded Four Dragons in review ***
— highest rating yet for non-games program

INSTANT GRAPH PLOTTER 2

An extension of the popular "Instant Graph Plotter 1" IGP2 has the additional facilities of text graphics anywhere on screen (horizontal or vertical text, numbers, arrows, etc.) Highly display-orientated, a few of the additional functions of IGP1 have had to be taken out of this version

Prices: Instant Graph Plotter 1 Cassette with 28-page Manual £7.50 incl. p&p

IGP1 and IGP2 28-page Manual Manual appendix for IGP2 £14.50 incl. p&p

IGP2 not available separately

NEW

ENDLESS NOUGHTS AND CROSSES

On a screen-wide grid

Get five noughts or crosses in a row to win (up, down or diagonal). Game for two, or play against the computer with Hint and Take-back facilities. Not for those with and I.Q. of less than 32k — especially if you don't like the idea of losing to a computer at noughts and crosses! Price £5.50 incl. p&p.

SPECIAL OFFER

IGP1+IGP2+Endless noughts and crosses for just £18.00 incl. p&p. For orders received by 30th April 1985. Cheque crossed P.O. to: R & P International, P.O. Box 129, Wembley, Middlesex HA0 2UG.

ANDTEK

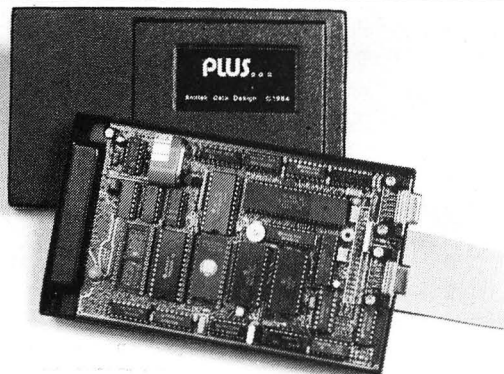

DRAGON 32/64 or TANDY COLOUR TRS80 FLEX THE TOTAL CONCEPT

TRANSFORM your DRAGON or TANDY home computer into a full 6809/Flex based system. ADD quality software support that only an established Disk Operating System can offer. Plus... consists of 6 separate peripheral units all within one completed interface, without requiring an expansion BUS. Connects directly into the cartridge socket. The internal features of the computer are unimpaired and can be returned to at any time. Accepts any standard Flex formatted disk.

FEATURES:

- ★ **DISC INTERFACE**, address compatible with DRAGON or TANDY controllers. Up to 4 single or double sided 40 or 80 track 5" drives, either single or double density working. Call for advice regarding other drive sizes.
- ★ **4K DEBUG MONITOR** with 25 user routines supports :- Full FLEX MON command, ROM BOOT for unconfigured FLEX disks, Enhanced keyboard routine, Communication to VDU terminal for 80 x 24 display.
- ★ **BATTERY BACKED REAL TIME CLOCK** and 50 bytes of RAM. Price — £129.00
Supplied with a full user manual and utilities disk The modular construction of Plus... allows extra facilities to be added as required.
- ★ **8K bytes of RAM** allows FLEX to run on 32K computers Price — £28.00
- ★ **Two serial RS232C ports** inc. Dual software programmable Baud Rate generators. Price — £38.00
- ★ **Flex DOS** (with HiRes., windows) including Editor and Macro Assembler. (Flex is a trade mark of Technical Systems Consultants inc.) Price — £75.00

OEM options allowing up to 96K of on card ROM, please contact us.

Prices include postage within the UK.
VAT must be added. Cheques or PO to:

**Andtek Data Design, 41 Pebworth Road,
Harrow HA1 3UD**

MICROBYTE TOP TEN BEST SELLERS

- | | |
|---------------------------|--------|
| 1 MANIC MINER..... | £7.95 |
| 2 RETURN OF THE RING..... | £9.95 |
| 3 TIM LOVES CRICKET | £8.95 |
| 4 BACK TRACK | £6.50 |
| 5 BUZZARD BAIT | £9.95 |
| 6 CHUCKIE EGG | £7.90 |
| 7 HUNCHBACK | £7.90 |
| 8 SPRITE MAGIC | £17.25 |
| 9 MR DIG | £7.95 |
| 10 SPEED RACER | £7.95 |

This chart is produced from actual counter sales (ie, tapes bought after the customer has tried them). If you are lucky enough to live near Microbyte pop in and test any software before you buy it. If you have to rely on mail order join hundreds of other satisfied customers by becoming a member of the MONSTER SOFTWARE CLUB.

Benefits include: ★FREE life membership when you buy one tape. ★Software for hire. ★All software at discount prices (at least 10%). ★All the latest titles. ★Up to date Top Ten lists sent to members.

Send Cheque/PO to:

MIRCOBYTE COMPUTER SHOP
19A Lower Warrengate
Wakefield WF1 1SA

Discount Software
Up to 50% off RRP

TITLE	PUBLISHER	MEDIUM	RRP	OUR PRICE
Advanced Basic Tutor	Ampsoft	Cass.	£14.95	£7.49
Area Radar Controller	SFA	Cass.	£7.95	£3.99
Back Track	Incentive	Cass.	£6.50	£5.20
Buzzard	Microdeal	Cass.	£9.95	£7.95
Data Base	MST	Disk	£24.95	£12.47
Dungeon Raid	Microdeal	Cass.	£8.00	£6.40
Eight Ball	Microdeal	Cass.	£7.95	£6.36
Frogger	Microdeal	Cass.	£7.95	£3.99
Hunchback	Ocean	Cass.	£6.90	£3.45
Infant Pack	Shards	Cass.	£3.95	£1.99
Learn Basic	Logic 3	Cass.	£12.95	£6.49
Leggit	Imagine	Cass.	£5.50	£2.75
Mr. Dig	Microdeal	Cass.	£8.00	£6.40
'O' Level Maths	Ampsoft	Cass.	£19.95	£9.99
Teleforth	Microdeal	Cass.	£19.95	£9.95
Wizzard War	Salamander	Cass.	£7.95	£3.99

These are just some examples of the discounts that we can offer.

Our price list covers over 100 titles and 27 books for the Dragon 32. To obtain a copy of our complete price list send SAE to the address below. If you wish to order any of the titles in this advertisement write to us giving the title, medium and our price + 50p P&P per order.

*Extra discount is available on orders of 10 or more titles.
Please allow up to 28 days delivery on all orders.*

JOHN PENN SERVICES
DISCOUNT SOFTWARE
Dean Farm, Kingsley, Nr Bordon, Hants GU35 9NG
Tel: 042 03-5970

MASTERSTROKE II

6K of finest machine-code which adds over 30 new basic commands to your Dragon 32/64 including:

- New Hi-res modes in all 9 colours
- Scroll in any direction
- Mix text/graphics
- Draw, move lines, boxes, triangles etc.
- 10 x 64 character function-keys
- Killrems
- advanced trace and list commands
- merge programs . . .

MASTERSTROKE II makes it possible for beginners and experts to program spectacular displays efficiently without having to use m/c. Price includes full instructions and free demonstration game: "Hyper-break".



PikaDee Software
35 Parker St., Preston
Lancs PR2 2AH

DUPLICAS 3 For use in making security back-ups for most of your software collection. Extremely easy to use. "Of the numerous back-up programs I have used this is the best" — D. M. Warrington. £7.95. Overseas add £1.00.

DICKIES DEN. Wander through the many rooms and dodge the nasties. But will you be able to rebuild the staircase and escape!! £7.95

DICKIE SPACE MAN. Our hero is in trouble again, but this time on another planet. Your job to help him re-build his space ship and escape. Pure machine code action. £7.95

TERROR CASTLE. A classic adventure where you have to rescue the princess. £5.95

THE SHRUNKEN SCIENTIST. You are only 1" tall will you get to the antidote and regain your height. £5.95

TOMBSTONE AND COD CREEK. Two classic games on one cassette. Excellent value for all the family. £5.95

Please send SAE for further details.
Add 30p P&P to all orders over £1.00
See us at the 6809 show

Available from **QUICKBEAM**
67 Old Nazing Road,
Broxbourne, Herts EN10 6RN

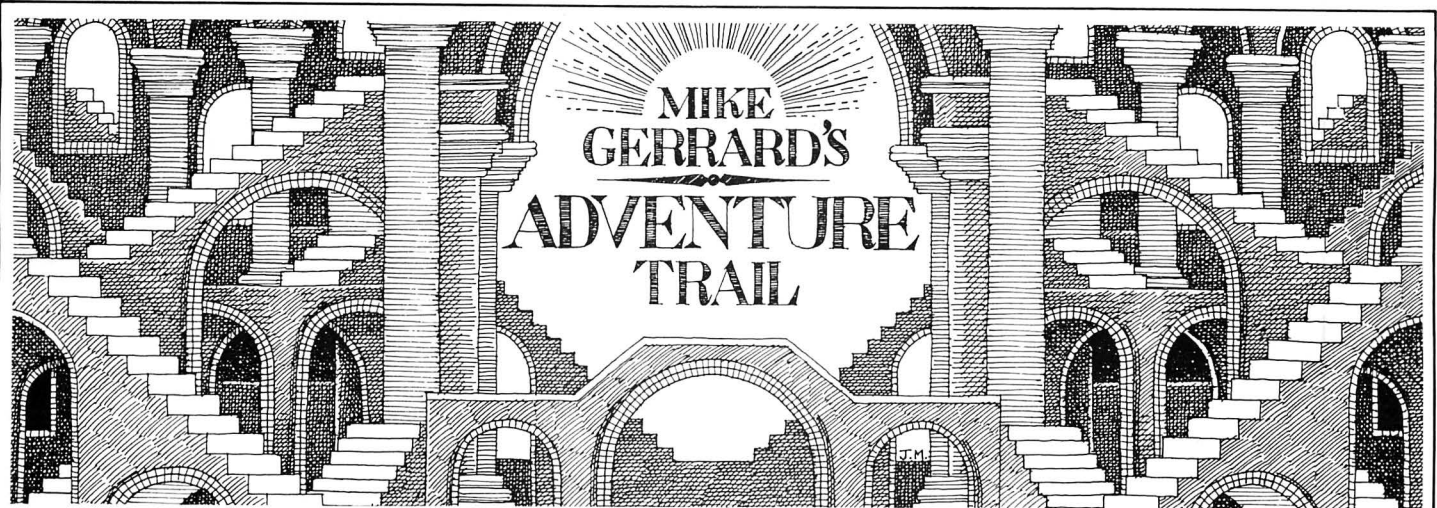

WHEN I WAS in Wigan at Christmas I noticed a distinct lack of Samurai around the town, but that doesn't stop a company from calling itself Samurai Software. If you send £7.95 to their offices at 4/6 Library Street, Wigan, you will receive in return a copy of their adventure, *Castle of the Skull Lord*, along with a free Dragon dust cover, which is a generous additional touch. I wish I could be equally generous about the adventure, but your ruthless reviewer has to be honest and say it's not the best he has ever seen.

The Skull Lord is a necromancer, who once attacked and defeated a race of noble dwarves, and now it's your duty to get into the Skull Lord's castle and retrieve a fabled crown for the dwarves, which was among the treasure stolen by the evil Skull Lord. The game is text-only, as are all the adventures this month, and accepts the usual two-word commands. For some reason there is no SAVE routine, which is a glaring omission as the BASIC program leaves quite a chunk of memory to play with in the Dragon. Once you've worked out the solutions to the first few problems, you don't want to continually go through them every time you load the tape, or encounter an unexpected death while you're playing.

The game begins with you on a barren plain, signs of war visible all around you, as indeed are exits, and you can also see a saw. Head north and there's a withered tree, and if you SAW TREE (having first taken the precaution of climbing it) you miraculously produce a stump and an oar! Amazing stuff. I'd have expected a stump and a felled tree, myself, but this is not an adventure for the realist.

Armed with an oar, you seek a boat and, having found one, you discover the limitations of the inputs allowed for in the program. Type ROW or ROW SOUTH (you're on the north bank of a river) and you're told "You can't do that yet," which is misleading as the command which works is ROW BOAT. The word "Yet" implies you need another object or to perform another task, not simply that the command is wrong.

Other examples of careless programming include a sequence in the mountains where your progress is blocked by an avalanche, and having found a spade to DIG SNOW, the avalanche reap-

pears every time you pass the location. The need for a SAVE routine is emphasised by the fact that if you reach the castle entrance hall and go WEST, you find "You are in a cell. There are no exits but the south wall looks very unstable". Ignoring the question of how you suddenly got in there if there are no exits, and that you shouldn't be imprisoned without warning, you obviously need a SAVE routine to experiment with problems like that. The tasks aren't difficult, and even with a free dust cover I can't really recommend this one.

Nor am I wildly enthusiastic about *Franklin in Wonderland* from Salamander, the first of what would have been a trilogy had the company not decided the Dragon adventure market was too risky. As it is, *Franklin in Wonderland* is available for just a fiver, without cover and instructions, but including the plastic wallet the cassette comes in. Before I go ahead with my grouchy comments, bear in mind that I didn't think much of Dan Diamond either, which I know puts me in a minority as far as Dragon adventurers go.

My major complaint is that whichever way you go at the start, you are in a maze, with no way of plotting a route through.

Drop your sweeties and that's the last you'll see of them. The first time I played I got through by fluke, and didn't bother saving a game so I could start beyond the maze, but several times after that I spent a fruitless 10 minutes at the keyboard travelling around, seeing the same location description literally hundreds of times, before giving up in frustration. Breaking into the program (it's in BASIC and unprotected) showed that there seems to be a random element at play in this first location, dictating whether you're able to get out of it or not. I'm prepared to be corrected on that, as it's hard to be certain without a full program listing, but it's not my idea of adventure playing.

Getting into the game has you falling down a deep dark hole into Wonderland, leading to illogical encounters with the Mad Hatter, March Hare, Cheshire Cat and so on. But, I was disappointed with this, and with Salamander's other "no-frills" adventure, *White Cliffs*, which gave me an OUT OF MEMORY error when loaded. That's taking no-frills too far!

Best of this month's batch (which isn't difficult) is *The Shrunken Scientist*, a bargain at £5.95 from a company new to me, Quickbeam Software, of 67 Old Nazeing Road, Broxbourne, Herts EN10 6RN. The title sets the story, as due to a slip-up in your lab you find yourself only one-inch tall, only able to regain your full height by getting to the top of the lab table and eating some of the crystals that are there. If being shrunken in size teaches you nothing else, it shows you what an untidy slob you are around the lab. On your travels you find rusty screws, bits of walnut shell, darning needles, even fingernails. I'd sack the cleaner myself. Great fun is had with the new perspective you've got: puddles become lakes, insects become monsters (and there are plenty of those, though DDT works wonders).

I've been having great fun with this adventure, discovering how to deal with the spider, the frog, and how to get out onto the window ledge without becoming a raven's breakfast, but I haven't yet figured out how to avoid composititis to enable me to get at the shirt button safely. The game has glaring faults, like no SAVE feature and sound effects which lock the machine forcing you to RESET (this happens in two places), but despite that it's enjoyable. ■

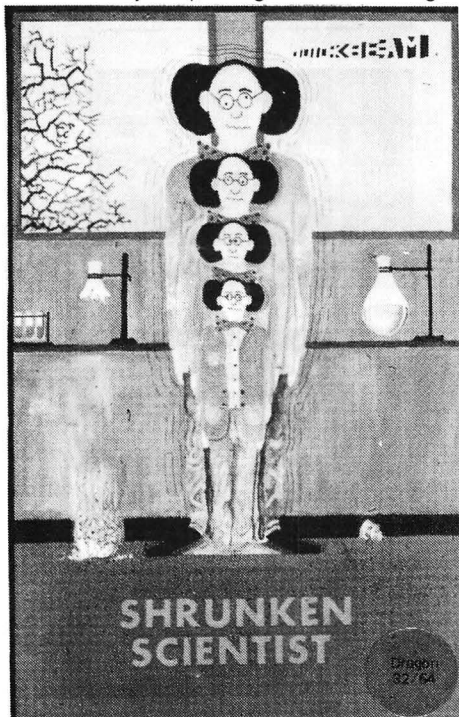

delta 14b handset.

The complete Dragon joystick system

Voltmace, the UK's largest computer joystick manufacturer has done it again... The delta 14b handset and interface for the Dragon 32 or 64 microcomputers.

Voltmace's well known delta shaped joysticks can now be found with more buttons, 11 more buttons, individually programmable for more action, more control, more glory. These additions have not however let us lose sight of why we are the UK's largest manufacturer, our design.

Super sensitive fingertip control with fast, centre sprung return action, means you always know where you are.

Tough, solid steel shaft, encased in a smooth nylon sleeve, handles even the roughest treatment and ensures hours of easy, fatigue free use.

New analogue potentiometers give corner to corner control, and total compatibility with all software currently available on the market. Switch joysticks as the word suggests can either be 'on' or 'off' and therefore cannot be used with programs that require analogue control, like flight simulators and computer aided design programs (C.A.D. 32).

Connection of the delta 14b handset to your Dragon micro-computer is made via the delta 14d interface. This plugs into the cartridge port of the Dragon with an external lead running to one of the joystick ports. No soldering or special technical

knowledge is needed to install either the handset or interface as everything simply plugs in.

Utilise the full potential of your delta 14b, (14 button handset), with our

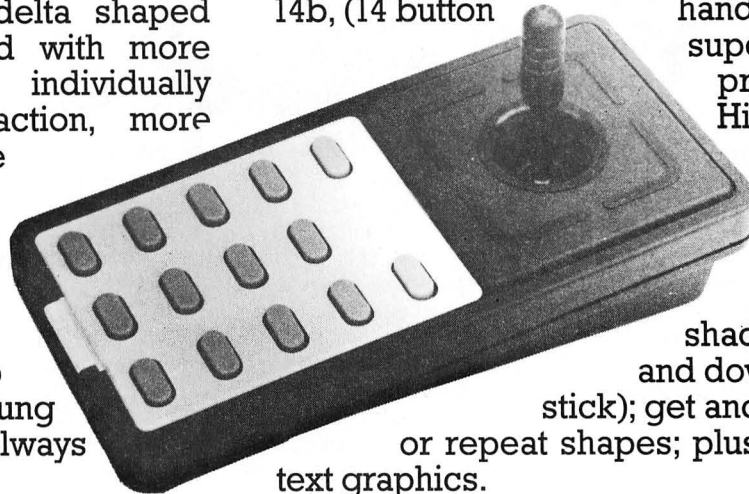

superb C.A.D. 32 program, using HiRes graphics draw: lines; circles; ellipses; boxes; fill in areas in four shades; scroll up and down (using joystick); get and put, to move or repeat shapes; plus two sizes of text graphics.

Unlike ordinary computer aided design programs C.A.D. 32 is really easy to use. The program is supplied on cassette with a printed overlay card for the 14b handset. Because the design functions are labelled and controlled from the handset, there is no

requirement for an on-screen menu which allows full use of the screen area for design work, you can now sit back and relax while your Dragon does the hard work. The screen dumps shown here were all produced with C.A.D. 32 using the delta 14b handset and interface. (Project X was designed and produced within 90 minutes). Finished or part finished designs can be saved to tape or disk and reloaded for printing or amendment. There is insufficient space here to describe fully everything C.A.D. 32 can do, so why not come along to the next 6809 show and see it for yourself.

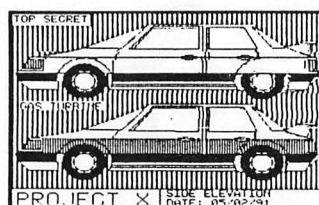
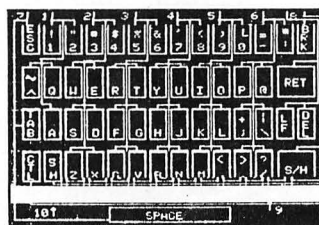
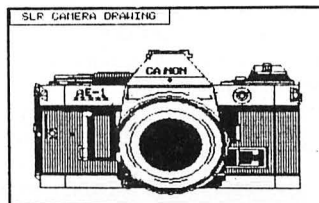

Voltmace Limited

Park Drive, Baldock, Herts. SG7 6ED. Telephone (0462) 894410

Callers welcome at the factory—Monday to Friday



Delta 14b handset & interface £29.95

C.A.D. 32 (on cassette)

£4.95

Access and Visa accepted

Prices include VAT and P&P

Bookbytes

Send books for review to *Dragon User*,
12-13 Little Newport Street, London
WC2H 7PP.

Book: *The Penguin Book of Personal Computing*
Author: John Graham
Publisher: Penguin
Price: £3.95

THIS WILL be a very short review — this book is absolutely superb and I really have no faults to point out. Not written for the ignoramus, it will, however, provide the educated reader with the ideal introduction to computing up to a standard somewhere around that of O-level Computer Science (the syllabus of which assumes that its student does not own a computer).

Within its pages are covered the development of the micro and personal computer, computer architecture, I/O, program development, programming languages, software, networking, system selection and a comprehensive contents list, Index, and five appendices, as well as a list of every illustration.

The computer book has matured and come down in price. Three years ago, had a book of this quality been available, it would have cost many more pounds than this excellent tome. The author is an experienced ICL programmer, and it shows! His text is precise, well written, and very well documented.

This book stands proud upon my bookshelf. I have nothing more to say.

Jason Orbaum

Book: *Forward 100*
Author: Ray Hammond
Publisher: Viking
Price: £12.95

MUCH HAS been said in the media recently about the turtle-graphics based language LOGO — the successor to Basic and Pascal in the "every-computer-should-provide-it-as-standard" argument. This book does not set out to continue the argument, nor does it try to teach the LOGO language, rather it sets out to explain what all the fuss is about. Hammond suggests that LOGO has tremendous value in the educational field because it teaches children to think logically and creatively, whilst at the same time being

fun. The theme of the book is neatly explained by Hammond in the first chapter:

"It is easy to motivate a child to learn LOGO; the problem is to explain its importance to adults."

The point of LOGO, according to the author, is not the syntax and power of the language itself, but the new approach to education that it allows. Hammond sees it as paving the way for an education revolution:

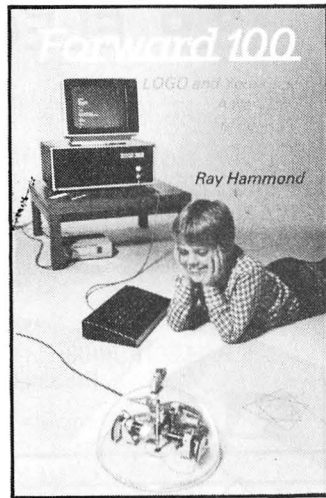

"Schools of the future will be centres of exploration with computers and databases providing information. Teachers will become guides rather than instructors."

If all this sounds mind-numbingly boring, well, it isn't. The author's obvious enthusiasm for the subject is infectious, and I found it hard to put the book down. Although at £12.50 it's rather expensive to buy, it's definitely worth going to your local library and ordering a copy.

David Rowntree

Book: *FORTH for Micros*
Author: Steve Oakey
Publisher: Newnes
Price: £6.50

BY NOW, every Dragon user must be aware that he or she is not stuck with the limitations of Basic as supplied with the machine. If program speed is the problem, the solution is either to buy a Basic compiler, or use another language altogether. Assembly language, the fastest of all, is

very fiddly to use and debug, so many people turn to intermediate languages like FORTH.

FORTH for Micros attempts to teach the language to those with programming experience in either Basic or Pascal, and points out that it is not an introduction to the subject of programming itself.

The book starts by introducing concepts such as stacks and reverse polish notation (the mathematical notation used by FORTH), and quickly moves on to simple programs. The early examples are given in Basic, Pascal and FORTH to make it easier to see what's going on. All of the usual topics are then introduced: selection statements; looping constructs; arithmetic; data types; input/output, ending up with a look at implementing large programs. The example programs shown include a multi-dimensional array implementor — a facility not available in standard FORTH. At the end of each chapter there are a selection of self-test exercises.

FORTH for Micros is a well written book that covers the main points of the language in an easy style, but there are a lot of FORTH tutors on the market about which one could say the same thing. There is nothing that makes this book stand head and shoulders above the rest.

David Rowntree

Book: *Arcade Games in BASIC*
Author: Bruce King Bell
Publisher: Reston
Price: £14.95

THIS IS a thinly disguised "15 super games for your..." type of book. Not much more need be said. If this is your type of book, then this one is excellent in its field offering competent versions of Break-out, Snake, Scramble (which has machine code in it — a fact which makes the title of the book somewhat dubious!), et al.

The programs are of a standard slightly above those you would find in computer magazines and they are very well documented, but almost every

one relies on the speed poke for one reason or another, and they are in BASIC, which is not a good language for arcade games.

The book is well written and I was pleased to see that it does not talk down to its readers. It credits its reader with a fair amount of intelligence at times, although the game introductions leave a lot to be desired, eg: "Nobody remembers why the war began. All that is known is that in the nuclear age the earth has quickly become war ravaged." All it needs is an "It was cold, too cold", and it will be a best seller!

The book's appendices are fairly competent and complete, giving Color Basic versions of the games for those with a Co-Co and no Extended Basic Cartridge (the Dragon comes with Extended Basic as standard), an "Index" of the major tutorial topics covered in each chapter, ie keyboard rollover table, joystick zoning and the like, and a final appendix of useful pokes and peeks not all of which seem to work (this could be because the book was quite obviously written for a Co-Co and re-covered).

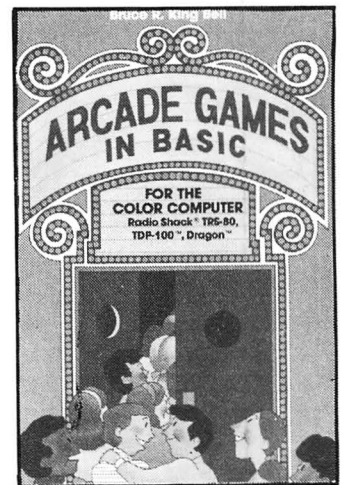

Overall then, a superior member of an inferior genre of book, but, as I have said, if the "Zap Pow and Bang with 30 games for your..." is your scene, then this is your book. And if not, it may still be worth a look by programmers as it does present some great examples of good programming (emphasis is on the word good, for the programs, by task definition, are not structured!).

Jason Orbaum

NEW LOWER PRICES

**MAGIC
MIDNIGHT**

DEFEAT HIS EVIL CREATURES AND
GAIN THE SPELL TO FIND
LACHLAN!

YOUR TROUBLES ARE ONLY JUST STARTING
FOR 1 OR 2 ADVENTURERS

INVEST IN THE STOCK MARKET,
BUY PROPERTY OR JUST GAMBLE
IT AWAY IN
RAT RACE

WILL YOU BE THE FIRST TO MAKE A MILLION
FOR 1-4 BUDDING BUSINESSMEN

PLAYABILITY IS THE NAME OF THE GAME

GAMES AVAILABLE MAIL ORDER ONLY
REDUCED PRICE NOW ONLY £5.00 EACH INC. P&P

MAGIC MIDNIGHT

30 HANDEL CLOSE, BASINGSTOKE,
HANTS. RG22 4DJ

48HR. DISPATCH
QUALITY PROGRAMS ALWAYS NEEDED

**DRAGON
IN FARNBOROUGH**

WE SPECIALISE ONLY IN DRAGON COMPUTERS
Approved Dragon Service Agent

Lots of software always in stock. Try before you buy

Latest titles available include: World of Flight,
Manic Miner, Backtrack, Cashman, Time Bandit,
Fury, Speedracer and Cuthbert in The Cooler

★ Books ★ Cassette Recorders ★ Printers and Printer Leads

Come and see us at:

165 Lynchford Road
Farnborough, Hampshire
Telephone: Farnborough (0252) 540125

S.P. ELECTRONICS

GP.....	£99.95
NEC 8023	£199.00
CP80A Dot Matrix Printer inc Cables	£230.00
PRINTER CABLE (Centronics).....	£12.90
CANON PRINTER 160CPS	£350.00

Large selection of new Salamander and Microdeal software
SAE for free list

All prices include VAT, carriage extra

S.P. ELECTRONICS, 48 Limby Road, Hucknall, Notts
(Nottingham 640377)



Complete repair service

DRAGON/32 BBC MODEL/B ATARI 400/800 TRS80 C/C 32K ELECTRON

747 FLIGHT SIMULATOR

Superbly realistic instrumentation and pilot's view in lifelike simulation which includes emergencies such as engine fires and systems failures. This program uses high resolution graphics to the full to produce the most realistic flight-deck display yet seen on a home computer. There are 21 real dials and 25 other indicators (see diagram). Your controls operate throttle, ailerons, elevators, flaps, slats, spoilers, landing gear, reverse thrust, brakes, etc. You see the runway in true perspective. Uses joysticks and includes options to start with take-off or random landing approach. "A real simulation, not just another game" (*Your Computer*, April 19 '83).

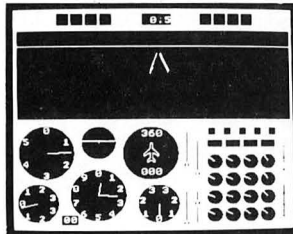

Cassette £9.95 (p&p and VAT included):

DACC Ltd (Dept. DU)

23 Waverley Road, Hindley,
Greater Manchester WN2 3BN.
(Despatch within 48 hours)

★★★ SPECIAL OFFER ★★★

High Quality PVC dust cover for your Dragon, worth £2.95, yours absolutely FREE when ordering 747 flight simulator.

New!! — Hardware for robotics, artificial intelligence, speech recognition, microprocessor control, etc.

ANALOG CONTROL INTERFACE

An Analog and Digital Control Board for Process Control and Data Acquisition for hobbyists, schools, colleges and industry. 8-bit A-to-D and D-to-A converters, bipolar buffered amplifiers, nine lines of TTL I/O, led status indicators, relay control.

SPECIAL PRICE £27.00 (+98p p&p)

Detailed Manual with full instructions and numerous application notes, along with Basic programs and machine code routines for use. Available mail order only from:

**ELECTROANALYTICAL TECHNOLOGY
COMPUTER DIVISION**

8 Access Road, West Derby, Liverpool L12 4YN



**ACE HIGH
(MK2)**
Machine gun warfare in the sky £6.95

TIME ATTACK
The armed TIME MACHINE
£6.95



Send £10.00 only for both of these full 32K games:
Telephone: 021-557 9286. Personal callers welcome

TUDOR WILLIAMS

15 Summerhill Road, Bilston, West Midlands WV14 8RD

GROSVENOR SOFTWARE

DREAM — DREAMBUG — ALLDREAM — DSKDREAM

FOR EASIER MACHINE CODE DEVELOPMENT

DREAM — Editor-Assembler — the most powerful and easiest to use package for writing machine code routines and programs. "Lives up to its name — a dream to use" — M. James "Language of the Dragon".

Full screen test editor, auto keyboard repeat. Forwards and backwards scrolling. Full symbolic assembler. Supports every aspect of the 6809.

DREAMBUG — Monitor, disassembler, tracer. For use with DREAM. Examine/change memory or registers. Dynamic/single/multiple step machine code instruction tracing through RAM or ROM. Supports up to 10 breakpoints. Conditional stop facilities with history command to show the path by which an error occurred. Disassemble/dump. Printer support. Converts DREAM to ALLDREAM. Tape £7.95.

ALLDREAM (DREAM + DREAMBUG) — Cassette £14.95. Cartridge £24.95.

DSKDREAM — Dragon DOS version of ALLDREAM. Supports text files on disk and direct disk to memory assembly. Disk £19.95.

UPGRADES available to convert from DREAM or ALLDREAM to DSKDREAM.

TEAM — Version of ALLDREAM for extended Tandy Color. Cartridge £29.95.

DREAMPRINT — Letter writing print adaptor for any version of DREAM. Tape £4.50.

All supplied with full manuals. Please add 40p P&P.

RADIO SOFTWARE BY G4BMK. RTTY — AMTOR — MORSE — BASICODE

Send SAE for full details

22 GROSVENOR ROAD, SEAFORD, EAST SUSSEX BN25 2BS
Telephone: (0323) 893378

If you've got a technical question write to Brian Cadge. Please do not send a SAE as Brian cannot guarantee to answer individual inquiries.

Dragon Answers

Switching to map 1

I HAVE an awkward question which I hope you can answer. I recently acquired a copy of a program (quite accidentally) which has the capability of switching to map1 and copying whatever you want into the upper 16K of RAM. Since I have been toying with the idea of reassembling the Basic to get rid of the bugs and improve its capabilities, I found this interesting and, although I haven't solved all the problems, one particular piece of the puzzle is still evasive.

A great deal of information was provided by the article in the January issue about map type 1. My question is — Under map type one does the SAM chip still access the interrupt vectors from \$BFF0-BFFF or are they mapped from \$FEF0-FEFF or do they revert to \$FFF0-FFFF?

*Robin Telkman
18 Arksey Terrace
Leeds*

THE DRAGON'S hardware is permanently configured so that the 6809 reads the contents of locations BFF2 to BFFF of the ROM for the interrupt and reset vectors, no matter whether you are in map 0 (ROM) or map 1 (RAM). Don't forget, however, that these interrupts have vectors which themselves point at vectors in RAM between 256 and 273 which you can change yourself.

Negative offset - a complement

WHEN USING the CLOADM command, it is possible to relocate your m/c program at a different address by using an offset. This is all well and good, but how do you get around the problem of relocating to a lower address? I have tried entering a negative integer, but the only result is an F/C error.

*Bill Lees
29 Athlone Ave
Bury
Lancs*

THIS PROBLEM with the CLOADM command comes up frequently, and is worth another mention. To achieve a negative offset you need to give the two's complement value of the negative number. That is 65536-N.

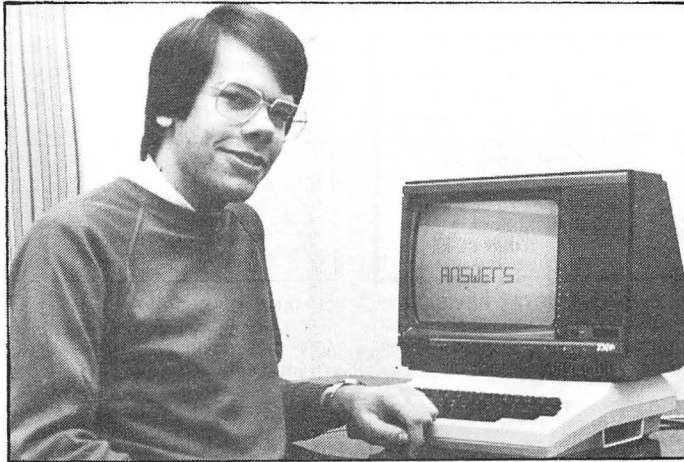

So, to do what should be: CLOADM''', -1000 you would type instead: CLOADM''', 65536-1000. This is just one of those bugs in the Microsoft Basic.

A skip in time saves . . . ?

TIMER=0: SkipF "Program": Print Timer/50. This would seem to provide a means of timing a program on a SAVE routine, but the value printed seems to indicate that the Timer stops while "SkipF" is taking place.

If this is so, surely the Timer will stop while any other operation takes place and therefore will never return an accurate value?

However, "Timer=0: For DL=1 to 100: Next: Print Timer/50" returns a value about one tenth of "Timer=0: For DL=1 to 1000: Next: Print Timer/50". What, therefore, are the limitations of Timer?

*P Crooke
Honeybank
Brittens Hill
Paulton
Bristol*

THE TIMER function can be used to accurately time any operation. It does not stop for normal basic commands, only those which use the cassette, such as CLOAD and CSAVE. This is necessary as interrupts must be disabled when reading or writing to cassette because of the critical timings involved.

As the timer function is updated by the interrupt routine, the value will not change during cassette operations. The same applies to disk reading and writing, but is less noticeable because of the speed of a disk drive. These are the only limitations of the Timer function.

Don't press the reset button

IS IT possible for me to make my Dragon crash on pressing the reset button? Also, is there any way in which I can use variables instead of program names when

Unplug your DOS cartridge

WITH THE reduction in prices of the Dragon disk drives, many more users now have access to a disk system. Sooner or later you realise that some games will not work with the DOS cartridge installed when loaded from tape as both the game and the DOS want to use the same RAM. The only option seems to be to unplug the cartridge. Doing this frequently will put the edge connector under a lot of stress and could damage the cartridge or your Dragon.

In the November issue of *Dragon User* I mentioned that it is

loading machine code from a Dragondos disk drive? I have tried the following routine, but so far have been unsuccessful:

```
10 INPUT AS
20 LOAD AS ".BIN"
```

*Richard Stevens
Heathercombe
Rosemary Avenue
Newton Abbot
Devon*

IT IS possible to make the Dragon freeze up when Reset is pressed. The only way out is to turn off and on again, so use these pokes with care, as you cannot regain the program in RAM. To make the Dragon freeze up on reset include these pokes in your program: POKE 114, &HAC : POKE 115, &HOF.

On your second point, it is possible to use variable names as dragondos filenames by using the "+" sign, your program should read:

```
10 INPUT AS
20 LOAD AS+".BIN"
```

possible to unplug the DOS cartridge using software. In response to the letters from Philip Ellis, Adam Caole, R Ruxton and many others here is such a program. Type the program in and save it on disk as, for example: SAVE "DETACH".

When you want to "unplug" the DOS, type RUN "DETACH" and press reset when requested. The program copies the basic cold start procedure from ROM and modifies it to ignore the DOS cartridge. To get the DOS back, just type POKE 113,0 and press reset.

The program should effectively detach any dos or similar cartridge, including Dragondos, Delta Dos, Ultra Drive Dos, etc.

```
10 ' DOS SOFTWARE DETACH V.1.1
20 CLS 1:PCLEAR 4
30 POKE 1541,2
40 FOR I=0 TO 146:POKE 3073+I,PEEK(45010+I):NEXT
50 POKE 3072,18
60 POKE 3197,0
70 FOR I=1 TO 3:READ S,F:FOR J=S TO F:READ A#
80 POKE 3072+J,VAL("&H"+A#)
90 NEXT J,I
100 DATA 148,156,8E,0C,9C,8D,90,E5,7E,83,71,157,188
110 DATA 44,4F,53,20,44,45,54,41,43,48,20,28,43,29,20,31,
39,38,35,20,44,52,41,47,4F,4E,20,55,53,45,52,00
120 DATA 13,17,8E,7F,FE,20,0E
130 POKE 114,12:POKE 115,0
140 PRINT@224,STRING$(32,140))
150 PRINT@256," PRESS RESET TO DETACH D.O.S."
160 PRINT@288,STRING$(32,131))
170 SCREEN 0,1
180 GOTO 180
```

Classified

DUST COVERS

★ DRAGON 32 & 64 ★

made-to-measure in quality natural vinyl with cut-outs for terminals and leads. Just send £2.95 (no stamp required) to:

ALLEN ENTERPRISES
Freeport, Luton LU2 8BR
Trade enquiries welcome

MEDIA CALC SPREADSHEET

AMAZING VALUE
 + - × % Average
 Plus all Dragon functions supported 756 cells plus overlay feature.
 Full instructions included all for only £9.99 inc

MEDIA MAGNETICS, Freeport
West Bromwich, West Midlands B70 6BR
 Agents required in countries other than Sp., S.A. & U.K.

SOFTWARE: Microdeal Games £2.50. S.A.E. P. McLean, Ridlands, Limp-saeld, Chart, Oxted, Surrey.

ALL SALAMANDER GAMES at discount prices, up to 60% off! Telephone: Nick 0628 26867.

DRAGON 64 disk drive, soft compusense flex, ed, asm, basic, 2 months old, worth £399 accept £350. Acounis evenings 0235 25055.

NEW DRAGON GAME, Iron Horse, can you drive your train across old west in record time fighting off Indians as you go? For 1 or 2 players, send £2.99 to K. Rose, 48 Roman Way, Felixstowe, Suffolk IP11 9NR.

DRAGON 32 screen enhancer gives your display easily operated new dimensions. 100% machine code with functions including: free mixing of text and graphics, upper and lower case redefinable characters, extended screen (32 × 24), works with unchanged basic programs, full documentation and tape plus free character redefiner program. Send £4.50 to New Dimensions, A. Watson, 28a Upwell Road, March, Cambridgeshire PE15 9DT.

CANOE

How far can you paddle up river. First negotiate the gates. If you succeed the river runs free, with rocks to challenge your paddle power. Unique paddle action, in 100% m/c with hi-res graphics and sound. Only £3.99. Cheques to:

CROUCHER COMPUTER SERVICES,
 14 Hiltbury Road, Havant, Hampshire.
 PO9 5SE.

DRAGON SOFTWARE. Discount Prices. S.A.E. for lists. Quantec, 87 Station Road, Ashington, Northumberland. Telephone 0670 854431. Agents for OKI Microline Printers

KANU 1000 New game for 1985. 4-event challenge. Bowling, Darts, Cricket, Soccer. Joystick required £3 D. Lockheart, 54 Shelley Road, East Grinstead, Sussex, RH19 1SY.

AMERICAN COLOUR Computer magazines, some back issues left, S.A.E. lists. Elkan Electronics, 11 Bury New Road, Prestwich, Manchester, M25 8JZ. Telephone 061-798 7613.

SIX EDUCATIONAL PROGRAMS. "O" level, prep, maths, business and more. Send £15. Professional Ed-Assoc., Suite 201-68, 6546 Hollywood Blvd., Hollywood, California 90028 USA.

OUTPUT PORT

Simply plugs into printer port and is easy to use from BASIC or M/C. Features Open-Collector outputs to drive relays, led's etc. Supplied with detailed information.

£14.95 inc. to:

NCJ Electronics
13 Binfield Square
Ella Street
Hull HU5 3AP

O LEVEL CHEMISTRY REVISION for Dragon and Compusense Hi-res, two cassettes £6 including p&p. Pensoft, PO Box 1, Penicuik, Midlothian.

CHRISTMAS OFFER! SooperFrooter (PMode 3) £2.99 cash. Vandervorst Wancourstraat 16, B-8410 Wenduine, Belgium. Free extras!!!

JOYSTICKS

Now with "ACCUTRAK" analogue movements for GAMES/CAD/CAM applications. Still best value at £12.95 per pair. Send now to PERITRON, Dept DU, 21 Woodhouse Road, London, N12 9EN

CUMANA DISK DRIVE, Delta interface, used one month only, warranty April 1985, £200 ono. 0491 34115 (Oxfordshire).

DRAWCASTER SCORE-DRAW FORECASTING SYSTEM

For serious Pools investors. Uses current form. Rates every team on the coupon and Homes-in on those elusive Draws.

Australian or British £6.50 (both versions £9.50)

Acepak Software
3 Brooks Road, Formby
Merseyside L37 2JL

LEADING SOFTWARE HOUSE offers definite commissions for specific machine language programs, with cash on completion plus royalties. Peaksoft, 48 Queen Street, Balderton, Newark, Notts. Tel 0636 705230.

DOWN-TIME, the Dragon cassette magazine, packed with arcade, utility, adventure programs. Over 90K loadable in 3 parts. Send £3.50 made payable to Mr M. Jefferson to Down-Time, 704 Bitterne Road, Bitterne, Southampton SO2 5QY.

SOFTWARE SAVERS. Top 50. Educational titles. Reductions. SAE for extensive list, 10 Fairways Crescent, Fairwater, Cardiff CF5 3EA, mail only.

DRAGON HITEXT. Place text on the hi-res screen with this machine language utility, features full upper, lower case, reverse field and double height characters, 448 definable characters, 51 × 24, 32 × 24 displays, 16 cls colours, 6 display modes, £4.95. Super basic, a machine language utility adding 58 commands to basic. Features 4 channel sound, alarm clock, function keys, procedures, error trapping, 33 colours, autorun on loading, plus lots more, £4.95 to: R. Thompson, 7 Brindley Way, Southall, Middlesex UB1 3JN. Tel: 01-571 3610.

JOURNEY TO THE CENTRE OF PHOBOS. A challenge for the skilled adventurer. Also ANTI-GRAVITY. Send £2.00 to: R. Kent, 39 Long Elms, Abbots Langley, Herts, WD5 0PF.

DRAGON PIRATE, can you become a successful pirate captain in one year, high resolution graphics, action with sound, strategy play. Only £2.95 inclusive from P. Mullin, 45 Forsyte Road, Saxonfields, Fenton, Stoke-on-Trent ST3 5SG.

DRAGON SYSTEM 32 with 64K Ram, upgrade plus Dragon drive, manuals, etc, £220 ono. Telephone 01-628 7217 (03745 58569 evenings.)

DRAGON HITEXT. Place text on the hi-res screen with this machine language utility. Features full upper/lower case. Reverse field and double height characters, 448 definable characters, 51 × 24, 32 × 24 displays, 16 cls colours, 6 display modes £4.95. Super basic. A machine language utility adding 58 commands to basic. Features 4 channel sound, alarm clock, function keys, procedures, error trapping, 33 colours, autorun on loading plus lots more! £4.95 to: R. Thompson, 7 Brindley Way, Southall, Middlesex UB1 3JN. Telephone: 01-571 3610.

The only figures that count

The circulation of this magazine is certified independently to professional standards administered by the Audit Bureau of Circulations

January-June 1984

35,379

ABC

The Hallmark of Audited Circulation

SUPER DRAGON WRITER II word processor (cartridge and tutorial) and Gemini database (cassette and guide). Duplicate Christmas presents, £35 complete. Telephone Belper 2193.

THE GAMES USER'S GROUP
 Join us and receive a 32 page magazine, "DRAGON SOFTWARE", which includes over thirty reviews. Exchange tips with other members. PLUS 15-25% off all software. Only £5.00 per year (six issues) or £3.00 for 6 months (3 issues). **ORON SOFTWARE, 64 PRINCE STREET, ROCHDALE, LANCs. OL16 5LJ.**
 Software houses — send software for review!

TANDY TP-10 PRINTER, very reliable, £40. Tel. (091) 2651944.

THEY'RE HERE! Unique softwares, Dragon 32 titles. 1: The Canal game, £4.95, P mode 4 graphics and excellent sound; 2: Colour screen copier for CGP-115 or compatible plotter, £1.95. Coming soon! Buzzin' Bertie, a multi level game. Make cheque/PO payable to Unique Software, 5 Milton Drive, Poynton, Cheshire SK12 1EZ.

H.R.G. SCREEN DUMP to Seikosha printer, or any similar seven wire head printer. Dumps from all graphics modes, choice of dump size and inverse option. Only £5. Cheques to: Croucher Computer Services, 14 Hiltbury Road, Havant, Hampshire. PO9 5SE.

WANTED. Dragon game cartridges. Tel: Blaby Computer Games, 0533-773641.

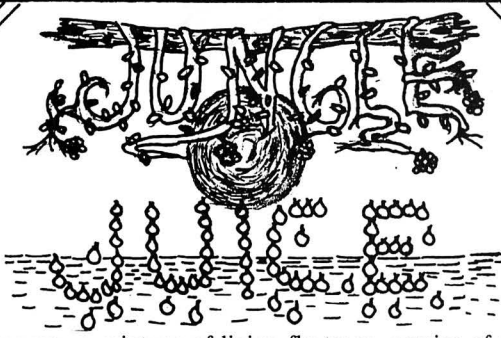

NEW

NEW

... gives you a mixture of living fly traps, armies of ants, and killer bees, that make this addictive game, graphically superior. Help guide 'WEE WILLIE' through nine increasing in difficulty waves. By tossing his pancake from one end of the room to the other, avoiding all obstacles.

JUNGLE JUICE - is a taste of things to come.
JUNGLE JUICE - is a computer game for the Dragon 32, with 1 joystick.

(Written in full 100% machine code).

special price **£5.95**



FANTASY SOFTWARE,
 22 WINSTOW AVE., STOCKSBRIDGE, SHEFFIELD, S30 5LA.



DRAGON 32

DRAGON 32 MODEM PACKAGE

- Comprising:
- ★ RS232 Interface
 - ★ Buzz Box Modem
 - ★ Cassette Software, gives a 40 character x 24 line screen display with upper and lower case text and an option of data printout, operates at 300/300 and 1200/1200
 - ★ Cable

Only £169.00 inc delivery

Free 9-page UK bulletin board directory with each purchase
 All Dragon Software available

COMPUTER SERVICE AND REPAIR CENTRE

COTSWOLD COMPUTERS
 6 MIDDLE ROW, CHIPPING NORTON, OXON
 Telephone (0608) 41232

Computape

27 COOMBE ROAD
 SOUTHMINSTER, ESSEX CM0 7AH
 Tel: MALDON 772589

Computape's new catalogue has over 260 Software Titles on Tape, Cartridge and Disk. Arcade Games/Adventure/Educational/Board Games/Utilities

MICRODEAL Crash Crazy Painter Morocco Grand Prix Pengon	TOM MIX Buzzard Bait RSP £9.95 OUR PRICE £8.95	CABLE SOFTWARE Quazimodo Super Bowl Zak-son RSP £6.95 OUR PRICE £5.95	A&F SOFTWARE Chuckie Egg RSP £7.90 OUR PRICE £6.90
NEW PROGRAMS ★ Cashman ★ Demon Seed ★ Downland ★ Fury ★ Time Bandit RSP £8.00 OUR PRICE £6.95	SALAMANDER Red Meanies RSP £7.95 OUR PRICE £6.95	PEAKSOFT Tim Love's Cricket RSP £8.95 OUR PRICE £7.25	HEWSON CONSULTANTS 3D Luna Attack 3D Seiddad Attack 3D Space Wars RSP £7.95 OUR PRICE £6.95
	SHARDS Pettigrews Diary Operation Safras RSP £7.95 OUR PRICE £6.95	OCEAN/Hunchback RSP £6.90 OUR PRICE £5.90	Hungry Horace Horace Goes Skiing RSP £5.95 OUR PRICE £4.95

Order from the above sending Cheque or Postal Order made payable to Computape and we'll send our Catalogue free of charge. For catalogue only send SAE.

Computape THE ONLY SOFTWARE COMPANY TO MAKE YOUR DRAGON CHIPS FRY NOT CRY.

Here's my classified ad.

(Please write your copy in capital letters on the lines below.)

£0.20	£0.40
£0.60	£0.80
£1.00	£1.20
£1.40	£1.60
£1.80	£2.00
£2.20	£2.40
£2.60	£2.80
£3.00	£3.20
£3.40	£3.60
£3.80	£4.00

Please continue on a separate sheet of paper

I make this words, at 20p per word (so I enclose £.....)

Name

Address.....

.....

.....

Telephone

Please cut out and send this form to: Classified Department, Dragon User, 12-13 Little Newport Street, London WC2H 7PP

ADVERTISERS INDEX

A	Microbyte..... 34
Andtek Data..... 34	J. Morrison (Micros)..... 21
B	O
Blaby Computers..... 9	Oasis Software..... 4
C	P
Commercial & General 38	Peaksoft 24
Compusense 16	John Penn Services..... 34
Computape..... 41	Pickadee Software 34
Computer Marketplace 12	
Computerware..... 25	Q
Cotswold Computers..... 41	Quick Beam..... 34
D	
DACC..... 38	R
Datacom Publications..... 30	R&P International 33
Datapen..... 27	Rainbow 20
E	S
Electronanalytical Technology..... 38	S.P. Electronics 38
F	Salamander Software..... 2
Fantasy Software 41	
G	T
Grosvenor Software 38	Touchmaster 8
H	Trojan Products 9
Harris Micro Software 24	Tudor Williams..... 38
Hot Co-Co 32	
I	V
Interface 24	Voltmace 36 & 44
M	W
Magic Midnight 38	Wintersoft 43
Microdeal..... 6	Wizzard Software 33
Micro-De-Bug 20	

RETURN OF THE RING

THE RING
OF
DARKNESS
PART II

At last the saga continues...

The Guardian of Shedir is defeated, the Hell spawned hordes of the Evil Sage lie at bay. Now Ringbearer, wielder of the Four Bright Rings, must face the greatest challenge: to return the Ring Of Darkness to its creators on the hidden planet Ringworld... And somewhere at the ends of time the forces of evil are preparing their revenge.

After one year of development, Wintersoft are proud to present the most sophisticated game ever created for the Dragon 32. Written 100% in machine code, RETURN OF THE RING is an astounding multi program blend of superb high resolution colour graphics and advanced routines that allow you to communicate with your computer in complete sentences. You will face challenge and excitement as you and your Ringworld companions travel a mysterious planet and brave the dangers of an amazing three-dimensional forest moon. An epic adventure unrivalled for its wealth of detail and diversity.

May luck travel your path.

Please note: RETURN OF THE RING is a complete adventure. You need not buy THE RING OF DARKNESS to play it.



WINTERSOFT
SOFTWARE

DEALERS PHONE
01-367 5720

WINTERSOFT
SOFTWARE

30 UPLANDS PARK ROAD,
ENFIELD, MIDDLESEX,
EN2 7PT

ALSO AVAILABLE:-

DRAGON 32

Return of the Ring £9.95
The Ring of Darkness £9.95
Dragon Trek £6.95

SPECTRUM 48K

The Ring of Darkness £9.95

ORIC-1 48K

The Ring of Darkness £9.95
Operation Gremlin £6.95

PRICES INCLUDE P&P, VAT, AND OUR LIFETIME
GUARANTEE.

SELECTED TITLES AVAILABLE FROM
LARGER BRANCHES OF



PLEASE RUSH ME:-

QUANTITY	TITLE	COMPUTER

I ENCLOSE MY CHEQUE/P.O. FOR £.....

NAME: _____ ADDRESS: _____

St. George now has two choices!

Red or green will slay the Dragon

- ▲ Nylon encased-Steel shafted joystick with ball and socket joint.
- ▲ Fast sprung return to centre.
- ▲ Graphite wiper linear potentiometers.
- ▲ 12 Months Guarantee.
- ▲ 7 day Money back Guarantee.

Complete control at your fingertips

The smooth control of the Voltmace delta sprung return joystick is now available to Dragon owners. Each joystick has been individually tested before it leaves our factory, following extensive robot testing to prove the design (we tested it more than a million times). This means that not only will your joystick be strong, tough and reliable, but it ensures long life, accurate control and with the choice of red or green fire buttons, gives instant recognition between the left and right joysticks.

If you are not completely satisfied with the delta 3d, return it to us within seven days for a full refund.



Dragon dealers come out of your caverns!

More stockists required in some areas.



Made in England

DELTA 3d JOYSTICK £10.00
TWO DELTA 3d JOYSTICKS £19.50
PLEASE STATE COLOURS REQUIRED

Prices include VAT and P&P.

Voltmace delta 3d

Callers welcome at the factory - Monday to Friday.

VOLTMACE LTD
PARK DRIVE
BALDOCK
HERTS
SG7 6ED
Tel: (0462) 894410

