

MAY/JUNE, 1980

ISSUE 4.

\$2.00

COMPUTE.

The Journal for Progressive Computing™



INTRODUCING THE
AMAZING!
 XYMEC HY-Q1000™

THE WORLD'S MOST INTELLIGENT PRINTER.

With more features than any other machine-
 regardless of price- it turns mild-mannered
 personal computers into super-powered word processors.

• **FASTER THAN A SPEEDING PRINT BALL.**
 Letter quality daisy print wheel lets you
 change type styles in seconds.
 • **MORE POWERFUL THAN COSTLY SOFTWARE.**
 5 built-in micro processors eliminate the need.
 • **RIGHT JUSTIFIES.**
 With 4 pitches plus proportional spacing.
 • **ABLE TO TYPE IN REVERSE**
 • **BOLD AS THEY COME.**
 Types in **Bold** face, underlines, centers titles,
 sets columns... all automatically.
 • **THE MASTER OF 6 LANGUAGES.**
 English, Italian, Spanish, French, German and
 Portuguese.

It's the most amazing printer on this or any other planet.
 Find out more at your computer store or call us from any phone booth.

SWTPC
 ALPHA MICRO
 OHIO SCIENTIFIC
 FAIRCHILD
 HEATH
 PET
 ATARI
 CROMEMCO
 APPLE
 NORTH STAR
 TRS-80
 BALLY
 TEXAS INSTRUMENTS
 EXIDY

Xymec

17791 Sky Park Circle, Suite H, Irvine, Ca. (714) 557-8501

Available at the best computer dealers or direct from Xymec. Dealers inquiries invited.

©1980 XYMEC

METAMORPHOSIS!

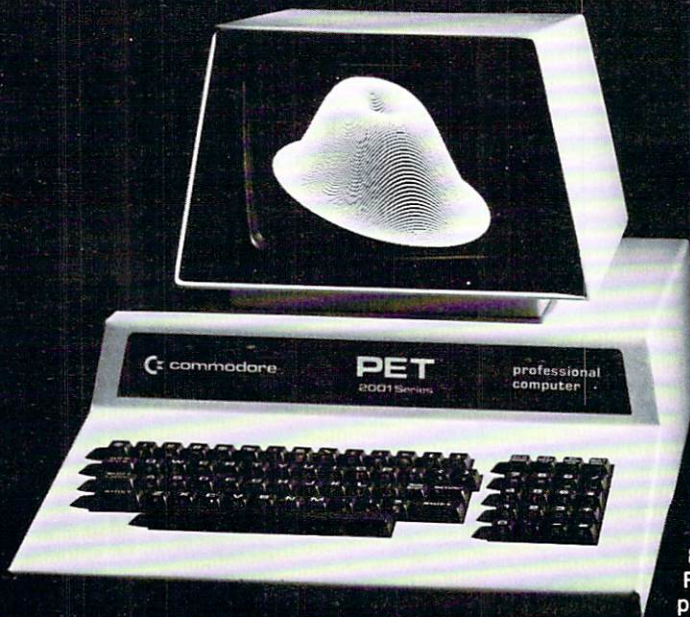

OLD OR NEW PETS CAN NOW HAVE HIGH RESOLUTION GRAPHICS

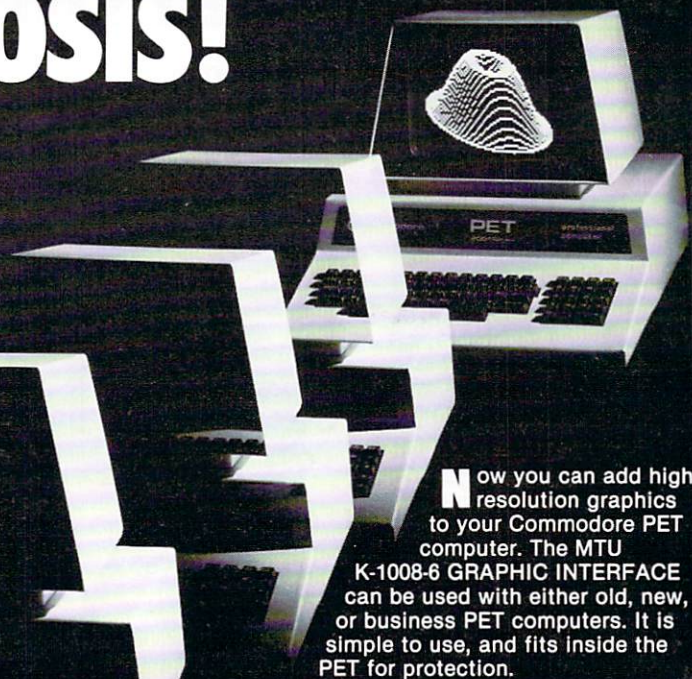
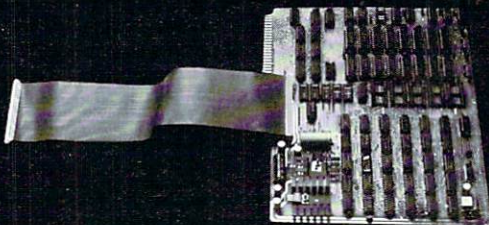

Now you can add high resolution graphics to your Commodore PET computer. The MTU K-1008-6 GRAPHIC INTERFACE can be used with either old, new, or business PET computers. It is simple to use, and fits inside the PET for protection.

The GRAPHIC INTERFACE gives you easy control over each dot in a matrix which is 320 wide by 200 high for a total of 64,000 dots. Because each dot can be controlled, either graphic images, text lines, or any mixture of the two can be displayed.

Since each dot is controlled by software you can even design your own special character font or graphic image set (logic, chemical, architectural).

INTERFACE TO ALL PETS - With separate connector boards for each style PET (K-1007-2 for OLD PETS, K-1007-3 for NEW). The K-1008-6 can be used with either.

THREE TYPES OF VIDEO - You can select either normal PET video, graphic video, or the COMBINED image of both video signals simultaneously!

8K RAM MEMORY EXPANSION - The graphic matrix requires 8K RAM which is supplied onboard. This memory can be used for program or data storage when not being used for graphics (or see your program in binary on the display!).

FLEXIBLY ADDRESSED ROM SOCKETS - Five ROM sockets are included on the board. They can be set *at the same* or different addresses, with you controlling which sockets are enabled at any time through software control. You also choose the sockets to be enabled when the PET is turned on.

EXTERNAL EXPANSION - This board also creates the KIM memory expansion bus supported by all MTU products. This allows insertion into our K-1005-P card file for expansion up to 4 other boards outside the PET case.

LIGHT PEN - The board has been designed to work with an optional light pen which MTU will be announcing soon.

SOFTWARE INTERFACED TO BASIC - MTU also has available machine language software to allow you to plot points, draw lines, and display characters at high speed.

Call or write for our full line catalog of products.

MICRO TECHNOLOGY UNLIMITED
P.O. Box 12106
2806 Hillsborough Street
Raleigh, N.C. 27605
(603) 627-1464

MTU
Micro Technology Unlimited
P.O. Box 12106
2806 Hillsborough Street
Raleigh, N.C. 27605
As of June 1, 1980

Professional Business Software

For The Commodore 32K Microcomputer System
With 2040 Dual Drive Disk & 2022 Tractor Feed Printer

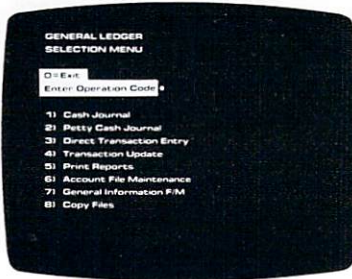

General Ledger

- Holds Up To 300 Accounts.
- Accepts Up To 3000 Transactions Per Month.
- Cash Disbursements Journal, Cash Receipts Journal, and Petty Cash Journal for simplified data entry.
- Maintains Account Balances For Present Month, Present Quarter, Present Year, Three Previous Quarters, And Previous Year.
- Complete Financial Reports Including Trial Balance, Balance Sheet, Profit & Loss Statement, Cash Receipts Journal, Cash Disbursements Journal, Petty Cash Journal and more.
- Accepts Postings From External Sources Such As Accounts Payable, Accounts Receivable, Payroll, Etc. **\$295.00**

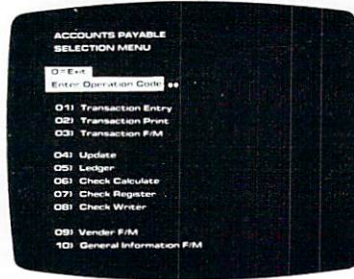

Accounts Payable

- Interactive Data Entry With Verified Input And Complete Operator Prompting.
- Automatic Application Of Credit And Debit Memos.
- Maintains Complete Purchase Records For Up To 200 Vendors.
- Invoice File Accepts Up To 400 Invoices.
- Random Access File Organization Allows Fast Individual Record Updating.
- Multiple Reports Provide A Complete Audit Trail.
- Check Printing With Full Invoice Detail.
- Full Invoice Aging.
- Automatic Posting To General Ledger ... **\$195.00**

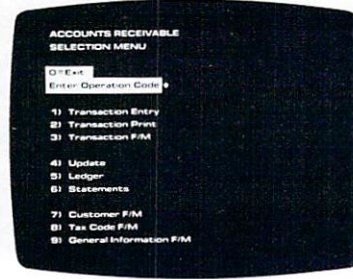

Accounts Receivable

- Maintains Invoice File For Up To 300 Invoices.
- Accomodates Full Or Partial Invoice Payments.
- Customer File Maintains Purchase Information For Up To 1000 Customers.
- Allows For Automatic Progress Billing.
- Provides For Credit And Debit Memos As Well As Invoices.
- Prints Individualized Customer Statements.
- Interactive Data Entry With Full Operator Prompting.
- Complete Data Input Verification And Formatting.
- Automatic Posting To General Ledger ... **\$195.00**

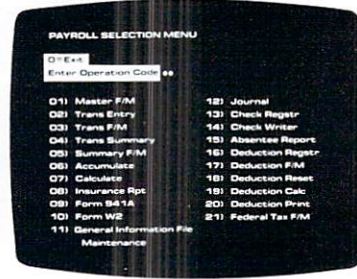

Payroll

- Maintains Monthly, Quarterly, And Yearly Cumulative Totals For Each Employee.
- Payroll Check Printing With Full Deduction And Pay Detail.
- Sixteen Different Reports Including W2 And 941.
- Interactive Data Entry With Easy Correction Of Entry Errors.
- Automatic Data Verification.
- Complete Job Costing Option With Cumulative Totals And Overhead Calculations.
- Random Access File Organization For Fast Updating Of Individual Records.
- Automatic Posting To General Ledger ... **\$350.00**

Structured around the time tested and reliability proven series of business software systems developed by Osborne and Associates, these programs have been designed to fill the need of a comprehensive accounting package for the new Commodore PET micro computer system. Each program can either stand alone, or be integrated with the others in a total software system.

Designed with the first time user in mind, these programs lead the operator through step by step, verified data entry. It is impossible to 'crash' a program due to operator error or invalid data input. Design consistency has been maintained from program to program to greatly increase operator familiarity and confidence.

Documentation, normally a problem for small systems users, is provided by the comprehensive series of Osborne

and Associates user manuals. These three manuals together total over 800 pages of detailed step by step instructions written at three levels for DP Department Managers, Data Entry Operators, and Programmers. You don't have to worry about getting 'promises' instead of documentation because the documentation was written before the programs were developed. A second set of manuals details any changes required during conversion. Each program provided on disk with complete documentation. Packaged in a handsome three ring binder with pockets and twelve monthly dividers for convenient storage of reports.

See your nearest Commodore dealer for a demonstration of this outstanding business software system.

CMS Software Systems

5115 MENEFFEE DRIVE • DALLAS, TX 75227 • 214-381-0690

Table of Contents

The Editor's Notes *Robert Lock*, 6
 Computers and Society *David D. Thornburg and Betty J. Burr*, 8
 Microcomputers and the Handicapped: The Delmarva Computer Club Column *Susan Semancik*, 13
 Product Feature: The Commodore 8032 ... *Larry Isaacs and Robert Lock*, 14
 Keeping Up the Payments: Basically Useful BASIC *Marvin L. DeJong and Robert Lock*, 19
 6502 Software Design (New Book Excerpt) *Leo J. Scanlon*, 21
 Computers: Boring, Boring, Boring *Ron Kushnier*, 27
 Inside Atari Basic *Larry Isaacs*, 31
 Book Review: Pet and the IEEE-488 (GPIB) Bus *Jim Butterfield*, 37
 Book Review: 6502 Software Design *Jim Butterfield*, 40
 Big Files on a Small Computer *Elizabeth Deal*, 42
 Using Pet's Second Cassette Buffer to Increase Memory Space *Chuck Stuart*, 48
 Enhancing Commodore's Word Pro III *Larry Isaacs*, 53
 Machine Language Tools *Jim Butterfield*, 57
 Algebraic Input For the Pet *Harvey Davis*, 58
 Pet Data Copier *Ron Straley*, 59
 Cross Reference for the Pet *Jim Butterfield*, 63
 Review: Digiclocks Printer *David Bosteel and Chuck London*, 66
 The Learning Lab *Marlene Pratto*, 69
 Structured Gaming in High School Computer Science *J.M. Moshell, G.W. Amann, and W.E. Baird*, 72
 A Pet "Answer-Box" Program *Thorwald Esbensen*, 74
 Pet-GET with Flashing Cursor *Gary Greenburg*, 77
 Two "mini" Reviews: Atari Basic Cards (Micronotions) Mailing List (Dr. Daley) *Robert Lock*, 79
 The Consumer Computer *Len Lindsay*, 83
 Review: D&R Cassette System *Robert Baker*, 86
 PETting With A Joystick *Harvey Herman*, 89
The Apple Gazette 91
 Appetivities at the West Coast Computer Faire *Joe Budge*, 91
 The Apple Pi Trading Library *Terry Taylor*, 93
 Interview with Taylor Pohlman, Apple's Product Marketing Manager *Michael S. Tomczyk*, 95
The Atari Gazette 97
 Introduction to "Three-Dimensional" Graphics for your Atari *David D. Thornburg*, 97
 Atari Tape Data Files: A Consumer Oriented Approach *Al Baker*, 99
 "Enter" with Atari *Len Lindsay*, 103
 Atari Program Saving, Part II *Len Lindsay*, 103
The Pet Gazette 104
 BAM- Block Access Map for Commodore Drives *Tom Conrad*, 104
 Rambling *Roy O'Brien*, 109
 Cheep Print, Part II *C.A. McCarthy*, 111
 Relocate Pet Monitor Almost Anywhere *Roy Busdiecker*, 115
 Pet Programs on Tape Exchange *Gene Beals*, 119
 Capute: Our Corrections Page *Robert Lock*, 120
 Pet Program Listing Explanation 120

Subscription Information:
 U.S. \$9.00/6 issue year
 CANADA \$12.00/6 issue year (U.S. funds)
 Europe: Air Subscription \$22.50 U.S./6 issue year
 Other areas: Inquire for air rates.

Address all articles, circulation questions and other inquiries to:
COMPUTE,
 P.O. Box 5406
 Greensboro, NC 27403
 (919) 272-4867

Dealers in Canada should contact:
Micron Distributing
 409 Queen Street West
 Toronto, Ontario M5V 2A5
 (416) 363-6058

In the United Kingdom and Europe, new subscribers and dealers should contact:

L.P. Enterprises **Ing. W. Hofacker GMBH**
 8-11 Cambridge House 8 Munchen 75
 Cambridge Road Postfach 437
 Barking, Essex West Germany
 England IG1 18NT (Germany, Switzerland,
 (United Kingdom and and Austria)
 Northern Europe)

Staff of COMPUTE:

Robert C. Lock, Editor/Publisher
 Carol Holmquist Lock, Circulation Manager.
 Larry Isaacs, Software/Hardware Lab.
 Joretta Klepler, Editorial Assistant.
 Marlene Pratto, Educational Assistant.

COMPUTE. receives continuing assistance from the following persons:
 Harvey B. Herman, University of North Carolina at Greensboro, Dept. of Chemistry. Editorial Assistance.
 David Gibbs, The Design Group, Greensboro, N.C., Art Direction/Design Consultation.
 Jim Butterfield, Toronto. Editorial Assistance.

The following writers contribute on a regular basis as Associate Editors:
 Gene Beals, 115 E. Stump Road, Montgomeryville, Pennsylvania 18936.
 Len Lindsay, 1929 Northport Drive #6, Madison, Wisconsin 53704.
 Roy O'Brien, Post Office Box 426, Beaumont, California 92223.
 Eric Rehnke, # 61, 540 S. Ranchview Circle, Anaheim Hills, California 92807.

Application to mail at controlled circulation postage rates is pending at Greensboro, North Carolina. Postmaster: Send change of address to COMPUTE, Post Office Box 5406, Greensboro, NC 27403.

COMPUTE is published by Small System Services, Inc., 900-902 Spring Garden Street, Greensboro, North Carolina 27403. Telephone: (919) 272-4867. COMPUTE is published six times each year on a bimonthly schedule. Subscription cost for one year is \$9.00. COMPUTE is available by subscription or through retail dealer sales. Subscription prices higher outside the US. (See below)

Address all manuscripts and correspondence to COMPUTE. Post Office Box 5406, Greensboro, N.C. 27403. Materials (advertising art work, hardware, etc.) should be addressed to COMPUTE., 900 Spring Garden Street, Greensboro, N.C. 27403.

Entire contents copyright © 1980 by Small System Services. Inc. All rights reserved, "COMPUTE. The Journal for Progressive Computing" is a trademark of Small System Services, Inc. ISSN 0194-357X.

COMPUTE. assumes no liability for errors in articles or advertisements. Opinions expressed by authors are not necessarily those of COMPUTE.

Authors of manuscripts warrant that all materials submitted to COMPUTE. are original materials with full ownership rights resident in said authors. By submitting articles to COMPUTE. authors acknowledge that such materials, upon acceptance for publication, become the exclusive property of Small System Services, Inc. Unsolicited manuscripts not accepted for publication by COMPUTE. will be returned if author provides a self-addressed, stamped envelope. Program listings should be provided in printed form as well as machine readable form. Articles should be furnished as typed copy with double spacing. Each page of your article should bear the title of the article, date and name of the author.

PET is a trademark of Commodore Business Machines, Inc. Apple is a trademark of Apple Computer Company. Atari is a trademark of Atari, Inc.

Advertisers Index

AB Computers 26	Instant Software 80,81
Abacus Software 24	International Technical Systems 108,117
Automated Simulations 85	Iridis 102
BYTE 9	Lemdata Products 39
CGRS Microtech 22,110	Micro Mini Computer World 38
CMS Software 2,108	Micro Computer Industries 50
Cognitive Products 71	Micro-Ed 60,61,DMC
Commodore Business Machines 15,16,17,18,52,BC	Micro Technology Unlimited 1,IBC,DMC
Competitive Software 118	Micromedia 78
COMPUTE's Book Corner DMC	Microphys 66,68,78
Computer Center of South Bend 87	NCE/Compumart 43
Computer House Div., 51,92,114	NEECO 4,5
FLC 51,92,114	Optimized Data Systems 50
Computhink 25	Osborne/McGraw Hill 36
Connecticut Microcomputer 28,29,62,117,120	Petted Micro Systems 108
Creative Computing 82	Programma International 88
Cursor 12	RAYGAM 35
Data Equipment Supply 55	Sawyer Software 46
Dr. Daley 11,86	Sebree's Computing 98
Eastern House Software 96,110,113,120	Silver Spur 62
Electronic Specialists 34	Skyles Electric Works 49,56,107,DMC
ETC Corporation 76	Softside Publications 94
Fantasy Games Software 114	Softside Software 65
G.E. Enterprises 110	Systems Formulate Corporation 41
GPA Electronics 79,96	Thesis 98
Hardside 30	TIS 37
Harry Briley 27	United Software of America 67
Hayden 20	Xymec IFC
House of Computers 78	Zeigler Electronic Products 47

*DMC = Direct Mail Card

NEECO

Microcomputer Systems Division

**PROUDLY ANNOUNCES THE NEWEST
HARDWARE AND SOFTWARE FOR YOUR PET!**

The PET is now a truly sophisticated
Business System with the announcement
of these peripherals and software packages.



**FREE
SOFTWARE
& PET DUST
COVER!**
(Offer ends
2/28/80)

NEW

NEW

NEW

PRODUCT	DESCRIPTION	PRICE	AVAILABILITY
PET 2001—8KN (Large Keys)	8K RAM	\$ 795	IMMEDIATE
PET 2001—8K	8K RAM	\$ 795	IMMEDIATE
PET 2001—16KN (Large Keys)	16K RAM*	\$ 995	IMMEDIATE
PET 2001—32KN (Large Keys)	32K RAM	\$1295	IMMEDIATE
PET 2023 PRINTER	ROLL FEED	\$ 695	IMMEDIATE
PET 2022 PRINTER	TRACTOR/ROLL	\$ 795	IMMEDIATE
ROMRETRO KIT	UPDATED O/S	\$ 90	IMMEDIATE
PET 2040	DUAL FLOPPY*	\$1295	IMMEDIATE
PET C2N	2nd Cassette	\$ 95	IMMEDIATE

*The 16K/32K (large keyboard) units do not include a cassette drive. Order C2N Cassette. 2040 Floppy Drive requires a 16K or 32K unit. 8K RAM Retrofit available July.

ALL PETS ARE FULLY TESTED BY NEECO BEFORE SHIPMENT. NEECO IS A FULL CUSTOMER-ORIENTED COMPANY. CALL FOR OUR FREE CATALOG. ALL ORDERS OVER \$795 WILL RECEIVE A FREE NEECO PET DUST COVER AND \$100 OF SOFTWARE FROM OUR CATALOG IF YOU MENTION YOU SAW THIS AD.

EDUCATORS TAKE NOTICE !

2 Commodore Computers **NOW = 3** Commodore (At least until Aug. 15th, 1980) Computers

Neeco is pleased to announce a Special Educational Program from Commodore Business Machines. Any bona fide school or educational institution will receive one CBM/PET Computer absolutely ★ Free ★ (direct from Commodore) for every two CBM/PET Computers Purchased at retail!

Contact NEECO for details and ordering information

EDUCATORS TAKE NOTICE !

PRODUCTS ARE AVAILABLE TO DEALERS VIA MICROAMERICA DISTRIBUTING (617-449-4310)



FOR WORD PROCESSING NEC IS BEST!

- * 55 characters per second output speed
- * Changeable thimble for different typesets
- * Less than 1% warranty malfunction rate
- * IBM quality letter output
- * Dealer inquiries invited

\$2995

*Price includes IEEE interface to PET. IEEE Port is available for use with 2040 Dual Disk.

THE NEC SPINWRITER
MODEL 5530-P (Centronics I/O modified for PET)

*The NEC 5530-P is the output printer recommended by Commodore for their Word Processing System.

NEECO

679 Highland Ave.
Needham, MA
02194

Mon-Fri 9:30-5:30

MasterCharge &

Visa Accepted

(617) 449-1760

Telex: 951021

MICROAMERICA DISTRIBUTING

"Nationwide distributors of Computer Equipment"

21 Putnam Street

Needham, MA

02194

(617) 449-4310



**NEECO
PROUDLY
INTRODUCES**

MULTI-CLUSTER

*"Multi User Management System for
Commodore CBM/PET* Computers"*

UP TO 8 CBM/PETS MAY NOW SIMULTANEOUSLY ACCESS ONE 2040!



Channel Module
CM-800



Multi-Cluster
Model MC-800A
Standard 3 Channels)

\$995

- Up to 8 Channel (3 Standard) for CBM/PET Computers.
- Up to 8 CBM/PETS can multi-use one Commodore 2040 dual disk drive simultaneously with equal access.
- Multi-Cluster supports all 2040 disk O/S commands including sequential, random access, and user files.
- Multi-Cluster does not utilize any RAM or ROM from the 2040 or host CBM/PET units.
- Multi-Cluster is compatible with all known software that utilize the IEEE port.
- Multi-Cluster can be fully implemented on 8 PETS, completely ready to use, in less than 15 minutes.
- Simply plug the Multi-Cluster unit into the IEEE port of the 2040 Disk Drive, then attach a Channel Module, #CM800, (3 Channel Modules are standard with unit), to the IEEE port of each PET.

THE MULTI-CLUSTER SYSTEM HAS BEEN USED AND FULLY-TESTED BY NEECO

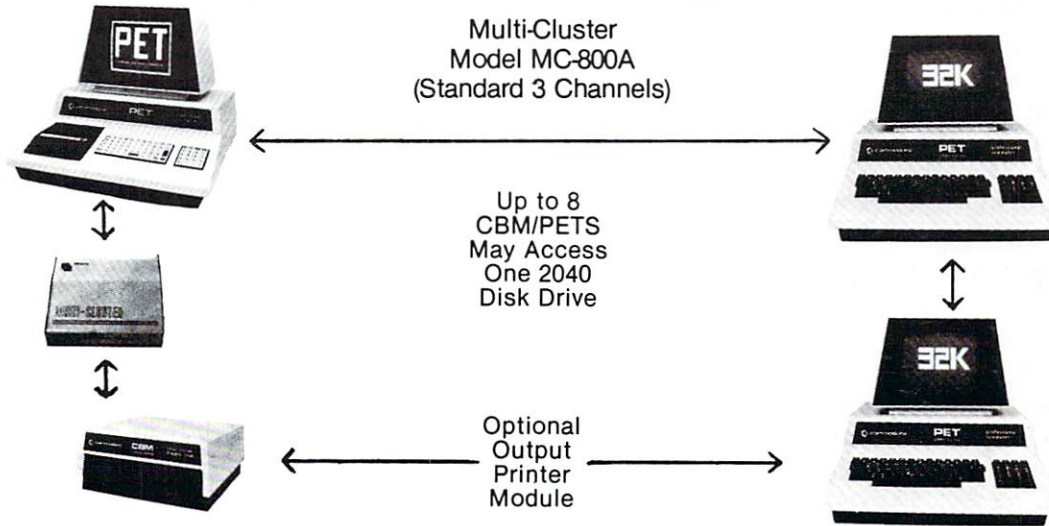

Multi-Cluster is ideal for industrial, OEM, Vertical Markets, and Educational Institutions. Multi-Cluster allows you to make full use of the Commodore 3 units for the price of 2 educational programs.

Output Printer Module allows 1 CBM/PET to scan 2040 Disk and print flagged files.

Standard Components:

- 1 Multi-Cluster #MC800A
- 3 Channel Modules #CM-100
- 3 6' Ribbon Cables #RC6

Optional Component Prices:

- Each additional CM-100 \$250
- Each 12' Ribbon Cable (RC12) \$ 40
- Each 18' Ribbon Cable (RC18) \$ 60
- Output Printer Module (PM200) \$200
(For Centronics Protocol Printers)

*PET is a registered trademark of Commodore Business Machines. Small Keyboard PETS require a ROM Retrofit Kit for Multi-Cluster system operation.

Multi-Cluster is available in Canada from BMB Compu Science, Milton, Ontario, (416) 878-7277



NEECO
679 Highland Ave.
Needham, MA
02194

Dealer Sales:
Microamerica Distributing
21 Putnum St., Needham, MA 02194
(617) 449-4310 **Telex: 951021**

Customer Sales:
NEECO
679 Highland Ave., Needham, MA 02194
(617) 449-1760

The Editor's Notes

Robert Lock

The Fifth West Coast Computer Faire San Francisco, California March 14, 15 and 16

A wonderful show! I guess I enjoyed it partially because it was our first West Coast show, and we got to meet many people we'd only talked to on the phone.

The show broke it's own attendance projections with close to 19,000 people. . . most of them computer user/consumers. One interesting point: Apple, Commodore, and Atari didn't show, deciding (I assume) to hold off for the NCC in Anaheim. Instead, large regional dealers were there, frequently receiving corporate staff support. On Saturday and Sunday, for example, Commodore corporate staff were assisting the Mr. Calculator people, and Atari retail training staff and support personnel were assisting several dealers.

An Apple Breakthru

Microsoft Consumer Products (the new end-user/dealer branch of Microsoft) introduced their first piece of hardware. Called the "Z-80 Softcard", it's simply a Z-80 board that plugs into your Apple, comes with Microsoft Disk Basic and CP/M operating system, and opens up a whole new world for you Apple owners. At a package price of \$349.00 (with June deliveries) they're being inundated. For the full details, read The Apple Gazette in this issue.

PET Owners Take Heart

Since the show, I've talked to both Commodore and Microsoft about the possibility of a Z-80 softcard for the PET. At this point, it hasn't been ruled out, so I'd like a show of interest. You'll find a direct mail response card in the center of the magazine to assist in the survey, and since I'm doing this on my own initiative, at my own expense, I've added a few other choices as well. I'll keep you posted on the results.

Other Highlights of the Show

Systems Formulate Corporation demonstrating their new line of "heavy-duty" business printers for the PET/CBM line.

Harry Saal of Nestar Systems demonstrating the Cluster-One System for the Apple.

Bob Skyles of Skyles Electric Works showing off his current line of PET products, including Macrotea, which started shipping a week before we sent you Issue 3's with a review indicating he still wasn't shipping. Oh well.

David Cox and Micro Technology Unlimited demonstrating their new 6502 DOS with a 20 KB transfer rate (!!!).

Atari reps trying to balance machine displays between new business software and Star Raiders, only

to keep finding them mysteriously returning (in mass) to Star Raiders.

Professional business software vendors emerging, with a lot of interest in **Word Pro III** at the Commodore/Mr. Calculator booth; **Compumax** and **Grass Valley** were also exhibiting/demonstrating their respective business software offerings.

Infoworld (the new weekly newspaper of micro-computing) had a nice touch supporting their time-liness. On Sunday morning they handed out a special Faire edition covering the Faire. Unfortunately, **COMPUTE.** didn't win the Apple they gave away.

Programma showing off their newest software offerings for PET, Apple and Atari, complete with a wide-screen TV so we could all watch.

Enough of this... on with Issue 4. Thanks, California, for an exciting show.

On Commodore's new ROMs and the 80 Column CBM

I've received a bit of flack for treating the new ROM introduction rather matter-of-factly. What can I say? I do feel the new 80 column machine can have a substantial impact on the emerging small business market, and I like the design of the unit. It makes sense to bring it out with the new Basic 4.0 as standard (e.g. built-in DOS). For the market it's designed for (small business, etc.) a built-in DOS is ideal (if not crucial). It presents a pain for those of you software vendors who are dilligently trying to keep up with Commodore, but at the same time, we can't encourage or expect them to take a no-growth position. There have been valid reasons (improvements) for each new set of ROM releases. I do think it's time to slow things down a bit. Certainly they must continue to support all existing units as they continue to introduce new ones. I will try to keep you posted as we find out what's what.

The IEEE-488 Acoustic Coupler

COMPUTE is still coupler-less. I appreciate your calls and letters asking for preview information, but I still don't have it. Our coupler should have arrived by now but hasn't. I promise (with Commodore's help) I'll have a review for new issue.

Good News for Apple and Atari Owners

Al Baker (of Al Baker's Game Corner in Interface Age and Image Computer Products) will be joining us with a column. Al Baker's Programming Hints will begin in Issue number 5 of **COMPUTE.**, providing helpful information to Apple and Atari owners. Look for his excellent article in this issue on Atari basic. **COMPUTE** grows on!

The Editor's Feedback

I mentioned earlier in this column my personal survey of your feelings on a Z-80 softcard for the PET. I've added other information to the card as well, and if you respond, will try to continue this process. The cards are a good way to get feedback to me in a concen-

trated form, and will help me keep the magazine on target. I feel that many of you won't write without some easy to use method such as this one. For those of you who want to take the time to write, please do. Eventually (note the eventually), I read all letters that come through here. Even when I don't have time to respond, the message is received. Here (with name removed) is a "wish-list" that one reader sent me. It was not intended for publication, but for my own information... that's why I've removed the name of the author. I'm printing excerpts from it because it's an excellent example of mail that's extremely valuable to me:

A Reader's Shopping List

1. Devote last page to corrections checklist. Herman's fantastic article in issue 2 has a typo in line 205; it should be POKE 53, 16 and not 24.

Okay, it's done. The last page is now reserved for previous goofs. Several readers have suggested a clearly defined location for fixes. From my end, I'll work on keeping the last page blank.

2. Provide clear diagrams of any hardware type articles. RESET button is a good example. My dealer is overworked and it is a crime for me to bug him about the location of one pin.

3. A tutorial on sys and usr functions. I have similar problems to Mr. Wachtel (HELP, Issue 2), and though I have given him a solution to one of his problems, others remain. The manual is of no help whatsoever.

Watch Issue 5 for this one...

4. Provide tapes of longer programs...

This request shows up on the Editor's Feedback card. I'll be curious to see what you think. Thanks, anonymous reader, for your input. I enjoyed the chat. Perhaps we'll call the last page "Capute!"

Writers

COMPUTE currently pays for unsolicited material (that we accept for publication) at a page rate of \$25.00 per published page. We also pay for little things, short program hints, three-liners, etc.

We expect to raise our rates as we grow, so stick with us. When you write for COMPUTE, you can expect three things: 1. You'll help other machine owners; 2. Your material won't sit around for six months; and 3. You'll appear in a young, growing magazine that now is distributed in the US, Canada, Great Britain, Europe, Australia, Japan, and a lot of places in between. Follow the directions on the title page for submitting your material to COMPUTE. When and if we ever publish your work again, as for example in "Best of COMPUTE." or "COMPUTE's Book of Atari", you'll be paid again, the second time at our then current page rate.

Business Software

HELP! I've added a spot on the Editor's Feedback card in an attempt to entice you business user's to provide some help. I know you're out there, so write.

Product Complaints/Problems

If you have a problem or complaint that involves a product in the micro industry, I'd like to offer the following guidelines:

1. Write (or call) the manufacturer/supplier. Most will cheerfully replace a defective product, or refund your money if you're not satisfied with the performance of the product.
2. Be fair with the supplier. Hostility, while understandable, is frequently not justified. A simple letter, stating the problem, should be as effective (or more so) than a threatening one.
3. If none of this produces results, drop me a note at the address below, and I'll look into it. I've had several "chats" with manufacturers recently as a result of reader complaints.

One final point: Don't jump to the worst conclusion. I think our industry is maturing. Magazines are certainly more alert to "scams", as are their readers. With good communications between readers, magazines, and advertisers, we'll resolve some of the problems of the past.

Articles, Programming Notes, New Product Announcements.

Material submitted for possible publication in COMPUTE should be addressed to:

Robert Lock, Editor
COMPUTE
P.O. Box 5406
Greensboro, NC 27403

©

Program Listings

For an explanation of COMPUTE's PET/CBM program listing codes, see page 120.



Computers and Society

David D. Thornburg
and Betty J. Burr
Innovision

P.O. Box 1317, Los Altos, CA 94022

Assuming that you are a personal computer enthusiast, you have no doubt noted that your approach to computers is different from that of some of your neighbors. We have spent many hours with people who are afraid that computers are responsible for all that is wrong with the world. While there is no one cause for this attitude, the following perceived characteristics of the computer world seem to be instrumental in perpetuating a fear of technology in some people:

1. Computers are only understood by "strange" genius level people who would rather hide out with machines than interact with other humans.
2. Computer technology will cost people their jobs.
3. Increased reliance on computer technology will make our society vulnerable to collapse from technological failure. (The New York blackout of some years back is often cited as an example of future woes in this regard).
4. Any small computer which fits in the home budget is little more than a toy - a glorified video game; the "real" computers are buried in the cellars of banks and large corporations.

Despite computer-phobic statements like these, the phenomenal revolutionary growth of computer technology will soon reach out to touch us all - computer users and non-users alike. The computer will soon be like the automobile. While we do not all need to drive cars to be functioning members of society, we do need to know enough about them to not walk out in the street without looking both ways. We would like to encourage you to take part in discussions with your friends to let them know more about the realities and promise of this technology, and we would like to make some suggestions that you might find helpful.

The remainder of this column will be devoted to background material you might find interesting yourself, and that you might want to share with those friends who engage you in discussions about computers. Books and movies are the principal media for information about computers, and the ways they may be used in the future. As we promised in the last column, we will present reviews of books in this column from time to time, and we will on occasion review relevant movies as well.

These are two types of books that lend themselves to inclusion in this column. The first is the "Role of the Computer in Society" book, and the second is the "I Don't Know Anything At All

About Computers But I Wish I Did" book. The first of these is typically quite philosophical in content, and is conducive to being read with furrowed brow and heightened social awareness. The second type of book is devoted to cutting through the mystery of computers and getting you to flex your fingers and start writing programs. In suggesting books of each type, we leave it to you to decide (after reading the books yourselves) which type might be appropriate for those of your friends who want to know more about this technology.

We must confess that our reason for suggesting that books be used to help you interact with your friends on this issue is based on a problem that one of us (DT) often has when giving a demonstration of a computer. As a professional in the personal computer field, he finds it all too tempting to start off at the right level and then to "show off" by running some zippy program written in half-BASIC half-machine code, all the time suggesting that the guest could generate programs twice as exciting in half the time. Trying, in the span of a few minutes, to demonstrate a complex system while trying "6 CTRL K RETURN", tossing out jargon left and right, and bringing up a super dazzling demo has turned off several people who would have much benefited from a softer approach. And, let's face it, you too really are a computer enthusiast, or you wouldn't be reading this magazine. Your enthusiasm for personal computers requires that you exercise tremendous restraint when demonstrating your system to someone who has never sat at a keyboard before. Good books can help build a buffer between your expertise and your neighbor's unfamiliarity and apprehension.

While there are many books we can write about, we thought that the following sampler should get you started towards building a library to share with your friends.

One of the better books on the social impact of computers is *Computer Power and Human Reason: From Judgment to Calculation*, by Joseph Weizenbaum (W. H. Freeman and Company, San Francisco, ISBN 0-7167-9463-3, \$5.95). Dr. Weizenbaum is a Professor of Computer Science at MIT who is widely known for his development of ELIZA, a natural language processing system. This system was used to create a script that made the system behave similarly to a Rogerian psychotherapist conducting an initial interview. The user would sit at a computer terminal keyboard and take part in a "discussion" with the computer in which it appeared that the computer "understood" what was going on. In fact, the program was looking for certain words in the user's responses and was using these words in later interactions. Of concern to Weizenbaum was that several psychoanalysts looked forward to this program paving the way to automated psychotherapy - something the author neither believed in nor intended.

Take the mystery out of programming

with the latest from *BYTE Books*tm

The BYTE Book of Pascal

Edited by Blaise W. Liffick

Based on the growing popularity of Pascal as a programming language, numerous articles, language forums and letters from past issues of *BYTE* magazine have been compiled to provide this general introduction to Pascal. In addition, this book contains several important pieces of software including two versions of a Pascal compiler - one written in BASIC and the other in 8080 assembly language; a p-code interpreter written in both Pascal and 8080 assembly languages; a chess playing program; and an APL interpreter written in Pascal. **\$25.00 Hardcover pp. 342 ISBN 0-07-037823-1**

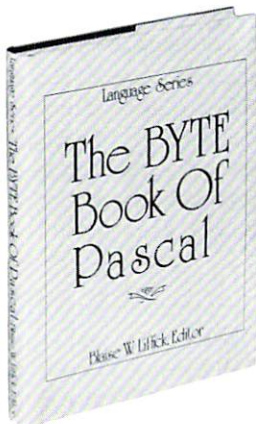

Beginners Guide for the UCSD Pascal System

by Kenneth Bowles

Written by the originator of the UCSD Pascal System, this highly informative book is designed as an orientation guide for learning to use the UCSD Pascal System. For the novice, this book steps through the System bringing the user to a sophisticated level of expertise. Once familiar with the System, you will find the guide an invaluable reference tool for creating advanced applications. This book features tutorial examples of programming tasks in the form of self-study quiz programs. The UCSD Pascal Software Systems, available from SofTech Microsystems Inc, 9494 Black Mountain Road, San Diego CA 92126, is a complete general purpose software package for users of microcomputers and minicomputers. The package offers several interesting features including:

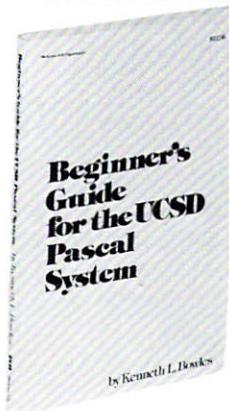

- Programs which may be run without alteration on the General Automation or DEC PDP-11 minicomputers, or an 8080, 8085, Z80, 6502, 6800, or 9900 based microcomputers.
 - Ease of use on a small, single-user computer with display screen and one or more floppy disk drives.
- \$11.95 ISBN 0-07-006745-7**

These and other *BYTE/McGraw-Hill* books are available from *BYTE Books* or your local computer store.



YOU JUST BOUGHT A PERSONAL WHAT?

by Thomas Dwyer and Margot Critchfield

Whether you are a novice programmer or an experienced computer user, this book is filled with practical ideas for using a personal computer at home or work. It will take you through the steps necessary to write your own computer programs, and then show you how to use structured design techniques to tackle a variety of larger projects. The book contains over 60 ready-to-use programs written in Microsoft and Level II BASIC in the areas of educational games, financial record keeping, business transactions, disk-based data file and word processing. **\$11.95 pp. 256 ISBN 0-07-018492-5**

Please send

- _____ copies of *The BYTE Book of Pascal*
 _____ copies of *You Just Bought a Personal What?*
 _____ copies of *Beginner's Guide for the UCSD Pascal System*
- Add 75¢ per book to cover postage and handling.

Name _____ Title _____ Company _____

Street _____ City _____ State/Province _____ Code _____

- Check enclosed in the amount of \$ _____
 Bill Visa Bill Master Charge
 Card No. _____ Exp. Date. _____

BYTE BOOKS

BYTE BOOKS Division • 70 Main Street
 Peterborough, NH 03458 Dept. V05



His book, then, is a discussion of the computer world from the standpoint of its potential and actual impact on society. Written to the level of the educated layman, this book shows what computers actually do, and then goes on to describe his concerns for a technology which has the power to radically change society. He suggests that the changes to come from the invention of the computer will be as profound as those which took place with the invention of the clock - that society will be irreversibly changed, for better or for worse, by computers.

When this book was published in 1976 it caused quite a stir in the computer science community. One of the topics discussed widely was Weizenbaum's description of the prototypical computer enthusiast, functioning as a "compulsive gambler" in a self-made universe: "Their rumpled clothes, their unwashed and unshaven faces, and their uncombed hair all testify that they are oblivious to their bodies and to the world in which they move. They exist, at least when so engaged, only through and for the computers. These are computers bums, compulsive programmers. They are an international 'phenomenon.'"

Hmmm!

While Weizenbaum's book preceded the advent of personal computers, it stands as a powerful work certain to stimulate much thought and conversation between you and your friends.

A more recent book, which concentrates on the personal computer revolution, is *Running Wild, The Next Industrial Revolution*, by Adam Osborne (Osborne/McGraw-Hill, Berkeley, CA, ISBN-0-931988-28-4). This book gives an exciting glimpse of the roots of the personal computer revolution and is concerned with the following major idea: the microprocessor was so radical an invention that established computer companies could not respond quickly to bring small distributed computing power to the public. It took new ideas and new lean companies to see the potential which lay in this technology.

Osborne goes on to suggest that if the big companies couldn't see the potential for this technology, then how can the bulk of the people in society understand and cope with its implications. His message is that the microprocessor has spawned a revolution, rather than it being part of an evolutionary development. A result of this thinking is Osborne's fear that blue collar workers will be displaced by robots soon, and that half of today's jobs will change drastically within the decade. The microelectronics revolution carries with it both promise and danger. This fast moving book is written for the layman and is fun to read.

Leaving the heavy stuff aside, we now come to a couple of books for those who want to learn to do some programming with no prior exposure to computers whatsoever.

One book we had to have for its title alone was *Computer Programming for the Complete Idiot*, by Donald McCunn (Design Enterprises of S.F., San Francisco, CA, ISBN-0-932538-04, \$5.95). This book was written by someone who only recently became involved with personal computers, and who realized the need for a book to help other neophytes cope with the idiosyncracies of sending instructions to a machine. Written from the standpoint of a TRS-80 user, most of his material is of relevance to users of the various 6502-based machines as well. He carefully illustrates the importance of proper syntax in communicating with computers and then goes on to illustrate the creation of a program by carefully constructing a small payroll program step-by-step. The choice of a mundane topic like payroll may not seem as exciting to you as a program to play Space Wars, but a large number of potential computer users seem to be concerned with having these machines do something "useful"; so from their standpoint, the choice seems pretty good. This is the type of book you can leave beside your computer to let your friends explore computer programming for themselves. If you can't find this book locally, it can be ordered from the publisher (P.O. Box 27677, San Francisco, CA 94127) for \$5.95 plus \$1.00 for shipping and handling.

Another fairly recent book that is very well written is *Basic and the Personal Computer*, by Thomas Dwyer and Margot Critchfield (Addison-Wesley Publishing Company, Reading Massachusetts, ISBN-0-2-1-01589-7). This book is published as part of Addison-Wesley's "Joy of Computing Series" and it assumes no prior computer experience on the part of the reader. Starting off with a straightforward description of computer jargon, along with a brief overview of the components which make up a computer, the book quickly moves to its main thrust: software. Rather than use one large program to illustrate various programming techniques, Dwyer and Critchfield create a large number of small programs which not only help to get various programming ideas across, but which are of interest in their own right. This is an exceptionally readable book which is made all the more enjoyable by the whimsical illustrations sprinkled throughout the text.

We could go on and on and perhaps we should publish a bibliography next time - what do you think? Anyway, we hope that these books are of interest to you.

Next time we might talk about the relation between Goedel's Incompleteness Theorem, Star Trek - The Movie, and the proof that machines cannot "think". How about it? If this sounds interesting, let us know. We welcome suggestions for topics, and more importantly, we want you to tell us how you feel. As we said before, this is your column as much as it is ours.

An Introduction to Small Business Software for the PET*. II.

Can DR. DALEY's offer a better Mailing List Maintenance System?

You've seen them all! Every software supplier offers a mailing list system of some sort or another. Each of them has some advantages and some disadvantages over the others.

So when DR. DALEY's decided to offer a mailing list we felt that it had to offer some other advantages over all of the others. We have offered—and sold some—mailing list systems before, but these offer few things that makes them unique.

SERIOUS BUSINESS

When you wish to purchase a software system for any business purpose you need to give it serious and thorough consideration. What do you wish to accomplish with the software? What are your needs? How can a computer assist you in filling these needs? We have asked these questions numerous times to people who do mailings with lists in the size range of 500 to 15,000 names. The result was unanimous: everyone has different information needs. This, of course, means that everyone who buys a mailing list system, or any other business software, must find a program that comes closest to his needs. This is a time consuming, expensive task. We've talked with businessmen who have become frustrated with this process and are ready to throw in the towel. Another option is to hire a programmer to write the software for you or to write your own. This can cost more than the cost of the computer.

The last option is to find prepackaged software which each individual user can easily configure to his own needs. This would allow each business to customize its own computer maintained mailing list files to, as closely as is possible, parallel the current mailing list operation. Until now, this option has been virtually impossible to fulfill, from any software publisher.

IMPLEMENTATION

Our computerized mailing list system is designed to be easy for you, the user, to be able to easily configure your files to contain information in much the same way as you currently are doing. This means less of the pain and anguish that frequently accompanies computerization.

During the programming the author was in frequent contact with potential end users. The main thought during the development phase was to make the operation easy to understand, yet powerful enough to handle the job. Give the user as many options as is feasible, with the flexibility to make the greatest possible use of the file information. Finally, be sure that

the capacity of the system is sufficient to allow most any business to make use of it.

The final version will allow records of 117 USABLE characters in length with a maximum of 15 fields within each record. It also allows reasonably large capacity with multiple diskette (maximum of 100 diskettes on a 32K PET or CBM) files and up to 1340 records per diskette.

WHAT ABOUT SORTING?

We hear this question most frequently from you. This is because sorting is the operation that divides the MAILING LIST system from any mailing list system. Why sorting? Well it is the way that the user can do such things as selective mailings to groups with common characteristics. This could include regional mailings, mailings to customers of a particular product, mailings to purchasers or to prospective customers, etc., etc. Or you might wish to make any possible combination of these categories.

Try to do this on most ordinary mailing list programs. You simply can't do it with most of the offerings on the market today.

This sorting is done by a "wild card" type of sort. This means that you can specify the contents of any portion of a field for a match and the computer will take any match for the rest of the field. This type of sort is best illustrated with the following examples:

A sort key can be: **R**1
Matches with FORT#1
and T4R321
and %/R@31

Our system allows this type of sorting using up to three fields within each record. Thus you should be able to retrieve almost any conceivable subset of the files.

File organization is done using two of the fields as sort keys. This again is user selectable. You could, for example, specify that you wish the file to be in ZIP CODE sequence or in alphabetical sequence and all records within the file will be sequenced with that field. There is also a second sort field which is used to sequence the file where the first field is the same.

WHAT ABOUT LABELS?

We hear this one almost as often as the

sorting. Well, here this is up to you. You can, at the time you print labels, choose the layout of the labels, you can also choose the number of labels per line. If you wish to have a four line address and printed four records wide you can do it.

WHAT ABOUT EDITING?

Editing is accomplished at several points in the program. These are at the time of entry, before saving the records to the file and from the disk file. You can easily modify any record at any of these points.

This does not really cover all of the operations on the files. Space simply does not allow a more complete description of the user oriented approach of the program.

We asked the question: Can we offer a better mailing list system? You bet we can! It's here now.

HARDWARE REQUIREMENTS

At present this requires a Commodore PET or CBM computer with a dual disk drive and a printer. It is set up to work with the Commodore printer or with most any other printer. Watch for these programs to be introduced for use with other types of popular microcomputers. The APPLE II version will be available about June 1, 1980. Watch for it!

ORDERING

At the present time many Commodore dealers do not carry our software. Thus you will most likely need to either persuade them to order for you or calling us directly at (616) 471-5514 anytime between noon and 9 p.m. Eastern time Sunday through Thursday. For only \$99.95 plus four percent tax in the state of Michigan, you get this powerful, field tested, fully documented program packaged in a convenient three-ringed binder.

INVENTORY

We must add this note. There is too little space to allow us to describe the INVENTORY system adequately here. It offers the same flexibility as does the MAILING LIST described above, but we can't tell you much more. Write or call for details. It also is priced at \$99.95.

Charge to
your
MC/VISA



DR. DALEY's Software
425 Grove Ave., Berrien Springs, MI 49103
Phone (616) 471-5514
Sun.-Thurs. noon to 9 p.m., Eastern Time

WHY IS CURSOR™ SO GOOD?

A Special Thanks to Our Talented Authors:

Howard Arrington
 Gary Bainbridge
 Chuck Bond
 Chuck Cares
 Hal Carey
 Art Carpet
 Sheila Dolgovich
 Ralph Dufour
 Greg Erker
 Glen Fisher
 Gary Flynn
 John Fox
 John Grove
 Julia Hallford
 Mike Hamilton
 Mark Heaney
 James Hinds
 Ken Kasmar
 George Leotti
 Randall Lockwood
 Martin Mabee
 David Malmberg
 Tom Marazita
 John Matarella
 Ken Matthews
 John Melissa
 Malcolm Michael
 Ken Morley
 Christopher Nadovich
 Norman Parron
 Mark Pelczarski
 Larry Phillips
 David Platten
 Donald Ross
 Herb Sandy
 Brian Sawyer
 Tony Schettino
 Larry Stevens
 Theodor Wagner

Maybe it's because we've always had high standards. Beginning with our first issue in July, 1978, we've published some 80 programs in our first 16 issues. Plus 16 animated graphic "Front Cover" programs. That's a lot of programs, a lot of code. Each program has been extensively edited by Glen Fisher, our Editorial Director. The result is obvious: Cursor programs reflect professional standards. We're proud of every program we publish.

But there's something else, too.

It's imagination. Our subscribers continue to be delighted with the new, fresh programming ideas that Cursor provides. Some of the best graphic animations for the Pet have appeared in Cursor. Teachers love us! They use Cursor as an example of what can be done on a Pet, with some skill and imagination.

Finally, there's service. Orders for single issues are almost always shipped within 24 hours. New subscriptions are processed within five working days. Should you get one of our rare defective tapes, just return it for an immediate replacement. And of course you can cancel your subscription at any time and we'll gladly refund all remaining issues.

Cursor: Quality. Imagination. Service.

For only \$3.95 you can buy a sample issue and judge for yourself. Or send \$20 for a six-issue subscription. You'll get six C-30 cassettes, each with five programs and a Front Cover ready to LOAD and RUN. With each issue you also get our Cursor NOTES, a lively commentary on the industry, as well as documentation for the programs.



Pet is a trademark of
Commodore Business Machines, Inc.

ORDER FORM

_____ Sample Copy of Cursor \$3.95 (California residents add 6% tax)

_____ 6 issues for \$20 (US & Canada. US Funds.)

Name _____

Address _____

City _____ State _____ Zip _____

VISA MasterCharge Expires: _____

Card Number: _____ Signature: _____

CURSOR
 Box 550
 Goleta, CA 93017
 Phone: 805-967-0905

**The Code
 Works™**

Formation of a COMPUTE Column for the Handicapped

Susan Semancik,
The Delmarva Computer Club

The Delmarva Computer Club is thankful for the many encouraging and enthusiastic letters we have received from people all over the country concerning our activities. We apologize for the length of time it is taking us to respond to some of the letters, but we are working on answering each letter on an individual basis. At the rate mail has been coming in lately, however, we will soon be spending more time answering letters than working on those programs for which the Club was formed!

The Editor of COMPUTE magazine has provided us with an opportunity to answer some of the common requests of these letters through his magazine and at the same time to provide a much needed "clearing-house" for information concerning help for the handicapped. In doing this, we are not trying to discourage correspondence, but are hopeful that answers to many similar requests can be quickly given through the magazine and that people needing special resources for the handicapped can be matched with those people who possess the programs, equipment, or innovative ideas to help the handicapped.

We encourage people and organizations to write to us concerning either their specific needs or their specific resources available. Even people with ideas that they themselves cannot implement should write in about them, and perhaps other people with either the needed ability or capital can join together to help make the ideas into a working reality to improve the quality of life for the handicapped. We would appreciate your including in your letters permission to publish in this column the information you give, for we will only make public those requests and offers for which permission has been granted.

We also plan, through this column to keep interested people informed of the progress we are making in specific program developments in the Club. Thank you again for your interest. We hope that you will all continue to respond, and will welcome this opportunity to openly exchange information.

Response to requests for the Manual Alphabet Tutorial Program on a PET

Our recent article on the PET Manual Alphabet Tutorial in COMPUTE's issue #3 resulted in many requests for obtaining the program. It is currently being updated and expanded, and will be available for purchase in approximately 6 weeks. We anticipate the selling price to be \$49.95, with discount prices for those buying in quantity. If you wish to order this program, please advise us so we can place your name on our waiting list. We really want to attempt to make this as effective a program as possible and are considering a novel approach to encourage feedback on the usefulness of the program: If through use of this program, you are the first to make a particular suggestion to us for its improvement and we incorporate your ideas in a revised edition of the program, we will update your copy of the program accordingly at no extra charge.

Response to Delmarva Computer Club Membership and Newsletter Requests

Our membership is currently restricted in our By-Laws to the Delmarva Peninsula, and our newsletter is an "in-house" publication, not meant for outside distribution. We are currently publishing articles and announcements about the Club's activities in COMPUTE magazine, and would suggest that interested people can follow the development of specific areas of interest through COMPUTE. We would appreciate correspondence with anyone wishing to share ideas and insights with us.

Response to Requests for a Computer Program Exchange

Since we are a small club that has only recently formed, our program library is rather limited at this date. We will forward letters requesting program exchanges for particular computers to those members who have the same equipment, and an exchange on an individual basis may be possible. We would appreciate people sending us listings of programs they have available for exchange, and we will keep them informed as our library grows.

The Delmarva Computer Club
P.O. Box 36
Wallops Island, VA 23337

©

One of the more positive experiences of getting this magazine started and rolling has been the chance to plug into the "mainstream" of microcomputing activity. The mainstream, I've found, isn't by implication the most well known activity... it's simply individuals or groups working hard to develop new uses for their micros. The non-profit Delmarva group may feel geographically isolated, at times, from the "mainstream"; personally I think they're at its forefront. I'm pleased we've found each other, and especially pleased at their relationship with COMPUTE.

Robert Lock, Editor/Publisher

PRODUCT FEATURE

The CBM 8032

Larry Isaacs, COMPUTE Staff
Robert Lock, Editor

When Commodore introduced the CBM and Professional computers, we were introduced to an upgraded BASIC and an upgraded machine that was more convenient to use. The same can be said for the introduction of the new 80 column machine called the CBM 8000 Business Computer. There will be two models, the 8016 (16K of memory), and the 8032 (32K of memory). Both models come with the business style keyboard.

The CBM 8000 series comes with BASIC 4.0. This BASIC has the disk commands built in. (For a good description of these commands, see Chuck Stuart's article on BASIC 4.0 in the March/April COMPUTE.)

The major external difference is the 12 inch monitor. Case size is adjusted appropriately, and the now familiar green CRT is standard. Resolution is good, especially when combined with the TEXT and GRAPHIC functions described below. Internally, the new version of the Main Logic Board has moved the second cassette port to the right side of the board (near the rear memory expansion header). You can now plug in a second cassette without opening the case.

Since line wrap-around for the screen is no longer needed in the operating system, a number of new screen editor functions have been added. Here is a brief description of each of these.

First of all, the REPEAT, TAB, and ESC keys are functional on the CBM 8000. Holding down the REPEAT key in conjunction with another will cause that key to be entered repeatedly. Cursor controls, insert and delete, and the spacebar repeat automatically. The TAB key causes the cursor to skip to the next tab stop. Shift-TAB is used to set or clear the current cursor position as a tab stop. The ESC key functions when the screen editor is in quote mode, or there are outstanding inserts. Hitting the ESC key will exit the insert and quote modes.

In addition, there are 11 new functions available. These are BELL, TEXT, GRAPHIC, INSERT LINE, DEL LINE, SCROLL UP, SCROLL DOWN, ERASE BEGIN, ERASE END, SET TOP, and SET BOTTOM. The CBM 8000 won't have keys corresponding to these functions, but with some additional software they can be accessed from the keyboard using a sequence of keystrokes. Also,

each of these functions has an assigned character value so they can be accessed under program control.

The BELL function uses CB2 sound, so you must add an external speaker if you want to use this one. Printing the appropriate character will sound the bell, as will reaching the 75th column when typing on the screen. The TEXT and GRAPHIC functions set the corresponding display mode. This involves more than selecting the character set. In text mode the lines are separated slightly to make them more readable. In graphic mode the lines are brought together so the graphics characters will touch.

The INSERT LINE, DEL LINE, SCROLL UP, and SCROLL DOWN functions operate as their name implies. When scrolling, blank lines are scrolled onto the screen, and lines scrolled off the screen are lost.

ERASE BEGIN erases, from the beginning of the line occupied by the cursor, up to and including the cursor position. The rest of the line and the cursor position are left unchanged. ERASE END erases from the cursor position to the end of the line, again leaving the rest of the line and cursor position unchanged.

SET TOP and SET BOTTOM are two functions which greatly enhance the usefulness of the 80 column screen. They allow you to define a portion of the 80 X 25 screen as a window. All screen editor and display functions operate only within this window, with screen contents outside the window left untouched. SET TOP sets the top left corner of the window to the current cursor position. SET BOTTOM sets the bottom right corner of the window to the current cursor position. After defining a window, you return to use of the full screen by hitting the HOME key twice.

These functions, when coupled with the 80 column screen, make the CBM 8000 series an aggressive entry into the small business market. Word Pro IV, the version developed for the 80 column machine, apparently includes the software necessary to interface with many of the Spinwriter special characters.

We expect commodore dealers to have units in the June/July time frame. Our word is that production is well along.

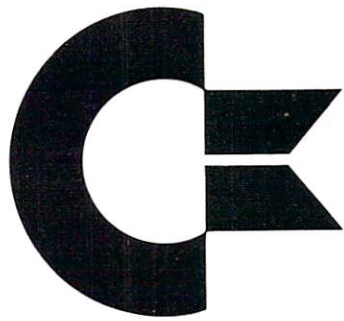

Commodore Authorized Dealers

APRIL, 1980

ALABAMA

ANDERSON
3156 University Dr. NW
Huntsville 35805
205-539-3444

BERNEY OFFICE EQUIPMENT
1718 Vaughn Rd.
Montgomery 36109
205-277-1601

COMPUTERLAND
3020 University Dr. NW
Huntsville 35805
205-539-1200

SC CORPORATION
246 South Court St.
Montgomery 36104
205-262-1961

THE LOGIC STORE
Lagoon Prk. Shopping Vlge.
Montgomery 36117
205-979-9797

RICKLES ELECTRONICS
2800 Meighan Blvd.
Gadsden 35904
205-547-2534

ALASKA

KLOPF WORKS
SR 51367
Fairbanks 99701
907-452-8502

T & A SALES
2600 Denali St. # 101
Anchorage 99503
907-276-6911

ARIZONA

ANCRONA
4518 E. Broadway
Tucson 85711
602-881-2348

COMMERCIAL & HOME SYSTEMS
7840 E. Broadway # 113
Tucson 85710
602-886-6850

EVANS NEWTON
7335 E. Butherus Dr. # P
Scottsdale 85260
602-998-2777

INTERPORT ASSOCIATION
5801 E. 22nd Street
Tucson 85711
602-747-5773

MICRO COMPUTER BROKERS
6819-P North 21st Ave.
Phoenix 85015
602-242-9961

MILLET'S ELECTRONICS
621 E. Broadway
Mesa 85204
602-964-1600

ARKANSAS

ABACUS, INC.
10 Smith Bldg. PO Box D
Conway 72032
501-329-9050

COMPUTERLAND
11121 Rodney Parham Rd.
Little Rock 72212
501-224-4508

COMPUTER PRODUCTS UNLIMITED
2412 Broadway
Little Rock 72201
501-371-0449

DATA SHOPPE
238 Central Mall
Ft. Smith 72903
501-452-4948

DATA SHOPPE
1000-C E. Maine
Van Buren 72956
501-474-8891

S.I.S., INC.
2201 Washington Ave.
Conway 72032
501-327-4471

CALIFORNIA

ACTIVE BUSINESS MCHN. INC.
23 Beta Court
San Ramon 94583
415-837-1167

ADVANCED COMPUTER PRODUCTS
1310-B E. Edinger
Santa Ana 92705
714-558-8813

ANCRONA
11080 Jefferson Blvd.
Culver City 90230
213-390-3595

ANCRONA
6060 Manchester Ave.
Los Angeles 90045
213-641-9322

ANCRONA
1300 E. Edinger Ave.
Santa Ana 92705
714-547-8424

ANCRONA
1054 El Camino Real
Sunnyvale 94087
408-243-4121

APPLE TV
2606 S. Robertson Blvd.
Los Angeles 90034
213-559-4261

AWARD ASSOCIATES, INC.
127 First Street
Ripon 95366
209-527-0206

BALDWIN MUSIC
1515 S. Broadway
Santa Maria 93454
805-922-8265

BUSINESS ENHANCEMENT CORP.
1711 E. Valley Pkwy # 109
Escondido 92027
714-741-6335

BYTE SHOP
6041 Greenback Lane
Citrus Heights 95610
916-961-2983

BYTE SHOP
1122 "B" Street
Hayward 94541
415-537-2983

BYTE SHOP
16508 Hawthorne Blvd.
Lawndale 90260
213-371-2421

BYTE SHOP
5453 E. Stearns St.
Long Beach 90815
213-597-7771

BYTE SHOP
11611 San Vicente Blvd.
Los Angeles 90049
213-820-1524

BYTE SHOP
1415 El Camino Real
Mt. View 94040
415-969-5465

BYTE SHOP
2233 El Camino Real
Palo Alto 94306
415-327-8080

BYTE SHOP
123 Yorba Linda Blvd.
Placentia 92670
714-524-5390

BYTE SHOP
8038 Clairemont Mesa Blvd.
San Diego 92111
714-565-8008

BYTE SHOP
986 Monterey St.
San Luis Obispo 93401
805-543-9310

BYTE SHOP
3400 El Camino Real
Santa Clara 95051
408-249-4221

BYTE SHOP
1555 Morse Ave.
Ventura 93003
805-647-8945

BYTE SHOP
2989 N. Main St.
Walnut Creek 94596
415-933-6252

CHANNEL DATA SYSTEMS
5950 Mandarin Ave.
Goleta 93017
805-964-6695

CITATION SYSTEMS, INC.
260 Sheridan Ave.
Palo Alto 94306
415-328-5630

COMPUTER CONNECTION
214 California St.
San Francisco 94104
415-781-0200

COMPUTER AGE, INC.
4688 Conroy St. # 105
San Diego 92111
714-565-4042

THE COMPUTER CORNER
1317 McHenry Ave.
Modesto 95351
209-529-9967

COMPUTER FORUM
14052 E. Firestone Blvd.
Santa Fe Springs 90670
213-921-2111

COMPUTERLAND
1625 El Camino Real
Belmont 94002
415-595-4232

COMPUTERLAND
6743 Dublin Blvd.
Dublin 94566
415-828-8090

COMPUTERLAND
2992 Navajo Road
El Cajon 92020
741-464-5656

COMPUTERLAND
11074 San Pablo Ave.
El Cerrito 94530
415-233-5010

COMPUTERLAND
22634 Foothill Blvd.
Hayward 94542
415-538-8080

COMPUTERLAND
6840 La Cienega Blvd.
Inglewood 90302
213-776-8080

COMPUTERLAND
4546 El Camino Real
Los Altos 94022
415-941-8154

COMPUTERLAND
24001 Via Fabricante
Mission Viejo 92691
714-770-0131

COMPUTERLAND
81 North Lake St.
Pasadena 91101
213-449-3205

COMPUTERLAND
1537 Howe Ave. # 106
Sacramento 95825
916-920-8981

COMPUTERLAND
289 E. Highlands Ave.
San Bernardino 92404
714-886-6838

COMPUTERLAND
4233 Conroy St.
San Diego 92111
714-560-9912

COMPUTERLAND
2272 Market St.
San Francisco 94114
415-864-8080

COMPUTERLAND
117 Fremont St.
San Francisco 94105
415-546-1592

COMPUTERLAND
1077 Saratoga-Sunnyvale Rd.
San Jose 95129
408-253-8080

COMPUTERLAND
1930 4th Street
San Rafael 94901
415-459-1767

COMPUTERLAND
223 S. Broadway # 332
Santa Maria 93454
805-928-1919

COMPUTERLAND
611 Fifth St.
Santa Rosa 95404
707-528-1775

COMPUTERLAND
171 E. Thousand Oaks Blvd.
Thousand Oaks 91360
805-495-3554

COMPUTERLAND
104 W. First St.
Tustin 92680
714-544-0542

COMPUTERLAND
1815 Yanacio Valley Rd.
Walnut Creek 94598
415-935-6502

COMPUTER PATHWAYS
12050 Nevada Cty. Hwy # 100
Grass Valley 95945
916-273-8474

COMPUTER PLACE
2539 W. Sepulveda Blvd.
Torrance 90505
213-325-4754

THE COMPUTER ROOM
1500 Graham Hill Rd.
Santa Cruz 95018
408-426-9473

COMPUTER TIMESHARING CORP.
5560 Ruffin Rd.
San Diego 92123
714-565-0505

COMPUTER WORLD, INC.
3808 W. Verdugo Ave.
Burbank 91505
213-848-5521

COMPUTER WORLD
15818 Hawthorne
Lawndale 90260
213-370-4842

COMPUTER WORLD, INC.
5848 Sepulveda Blvd.
Van Nuys 91411
213-786-7411

COMPUTER WORLD, INC.
6789 Westminster Ave.
Westminster 92683
714-898-8330

DATA EQUIPMENT SUPPLY
8315 Firestone Blvd.
Downey 90241
213-923-9361

EDUCATIONAL MICRO SYSTEMS
1527 28th St.
Sacramento 95816
916-452-3609

GRASS VALLEY COMPUTER
18430 Jayhawk Dr.
Smartville 95977
916-272-2793

INTL INST. OF NATL HEALTH
7422 Mountjoy
Huntington Beach 92647
714-848-0774

JAY-KERN ELECTRONICS
1135 Columbus
Bakersfield 93305
805-871-5800

K. SMITH ASSOCIATES
11 Mast Court
Sacramento 95831
916-392-0317

LANTOR, INC.
8055 Manchester Ave.
Playa del Rey 90291
213-821-0642

LYON TV
19515 Village Dr.
Sonora 95370
209-532-4894

MATTHEWS TV & STEREO
6040 Mission St.
Daly City 94014
415-992-5400

MR. CALCULATOR
160 E. El Camino Real
Mt. View 94040
415-962-0335

MR. CALCULATOR
55 Third St.
San Francisco 94108
415-543-1541

MR. CALCULATOR
318 Town & Country Village
San Jose 95128
408-246-5710

MICRO COMPUTER WAREHOUSE
3620 LaHabra Way
Sacramento 95825
916-322-3290

MICRO DISTRIBUTORS
2737 Croddy Wy. Unit E
Santa Ana 92704
714-641-0205

PARADYME CONSUMER ELECTRONICS
404 Second St.
Davis 95616
916-785-5210

PASCO SCIENTIFIC
1933 Republic Ave.
San Leandro 94577
415-351-1501

PC COMPUTERS
10166 San Pablo Ave.
El Cerrito 94530
415-527-6657

PROGRAMMABLE ELECTRONICS
1748 W. Chapman Ave.
Orange 92668
714-978-6587

RADIO MART
1075 Cypress Ave.
Redding 96001
916-241-3000

* Denotes dealer buying directly from Commodore

Authorized Dealers

- SYSTEMS FORMULATE CORP.**
39 Town & Country Village
Palo Alto 94301
415-326-9100
- COLORADO**
- AMPTEC**
2310 Providence Circle
Colorado Springs 80909
303-597-5384
- AMPTEC**
5975 No. Broadway
Denver 80216
303-571-0833
- BYTE SHOP**
3101 Walnut St.
Boulder 80301
303-444-6550
- BYTE SHOP**
300 E. Foothills Pkwy
Ft. Collins 80525
303-223-4000
- BYTE SHOP**
970 So. Oneida
Denver 80224
303-399-8995
- COMPUTERLAND**
8749 Wadsworth Blvd.
Arvada 80005
303-420-1877
- COMPUTERLAND**
4543 Templeton Gap Rd.
Colorado Springs 80909
393-574-4150
- COMPUTERLAND**
2422 S. Colorado Blvd.
Denver 80222
303-759-4685
- MICRO COMPUTER INDUSTRIES**
1520 E. Mulberry, Suite 240
Ft. Collins 80524
303-221-1955
- MICRO WORLD ELECTRONIX**
6340 W. Mississippi
Lakewood 80226
303-936-4407
- NEIGHBORHOOD COMPUTER STORE**
13045 W. Alameda Pkwy.
Lakewood 80215
303-988-9140
- CONNECTICUT**
- COLONIAL ENTERPRISES**
360 Broad Street
New London 06320
203-442-2798
- COMPUTERLAND**
1700 Post Rd. Heritage Sq.
Fairfield 06430
203-255-9252
- COMPUTERLAND**
55 Pratt Street
Hartford 06103
203-727-1857
- CONNECTICUT MICROCOMPUTER**
150 Pocono Road
Brookfield 06804
203-775-9659
- HAASE OFFICE MACHINES**
908 Washington Blvd.
Stamford 06901
203-359-4680
- MULTI BUSINESS COMPUTER SYSTEMS**
28 Marlborough St.
Portland 06480
203-342-2747
- DELAWARE**
- COMPUTERLAND**
Astro Shopping Center
Newark 19771
302-738-9656
- DISTRICT OF COLUMBIA**
- COMPUTER EMPORIUM**
1990 K Street NW
Washington DC 20006
202-466-3367
- FLORIDA**
- ACCURATE COMPUTING SERVICE**
785 N. Lake Blvd.
North Palm Beach 33408
305-842-4900
- COMPUTER CENTER**
6578 Central Ave.
St. Petersburg 33707
813-343-1396
- COMPUTERLAND**
500 E. Spanish River Blvd.
Boca Raton 33432
305-368-1122
- COMPUTERLAND**
274 Alhambra Circle
Coral Gables 33134
305-442-4112
- COMPUTERLAND**
3963 N. Federal Hwy
Ft. Lauderdale 33308
305-566-0776
- COMPUTERLAND**
2777-6 University Blvd.
Jacksonville 32217
904-731-2471
- COMPUTERLAND**
7374 S. Tamiami Trail
Sarasota 33581
813-921-7800
- COMPUTERLAND**
1520 E. Fowler Ave.
Tampa 33612
813-971-1680
- COMPUTERLAND**
4275 Okeechobee Blvd.
West Palm Beach 33409
305-684-3338
- COMPUTER SPECIALTY**
3820 Minton Road
Melbourne 32901
305-727-5147
- COMPUTERS FOR YOU**
3608 W. Broward Blvd.
Ft. Lauderdale 33312
305-581-8945
- CREATIVE EQUIPMENT**
50 NW 68th Ave.
Miami 33126
305-261-7866
- FLORIDA BOOK STORE**
1614 W. University Ave.
Gainesville 32604
904-376-6066
- FOCUS SCIENTIFIC**
224 N. Federal Hwy
Ft. Lauderdale 33301
305-462-1010
- FOCUS SCIENTIFIC**
1601 Biscayne Blvd.
Miami 33132
305-358-3948
- MIDWEST CORP.**
3341 NW 82nd Ave.
Miami 33122
305-592-5355
- MONEY MANAGEMENT**
904 Oakview Ave.
Clearwater 33516
813-443-5073
- ORLANDO ELECTRONICS CO.**
2356 W. Oak Ridge Road
Orlando 32809
305-855-1010
- PROFIT CONCEPTS, INC.**
3300 University Dr.
Coral Springs 33065
305-753-8303
- UNITED SYSTEMS & SOFTWARE**
P. O. Box 117
Winter Park 32789
305-647-2251
- GEORGIA**
- ACTION BUSINESS MACHINES**
1684 N. Atwood Drive
Macon 31204
912-474-3333
- ANCRONA**
3330 Piedmont Rd.
Atlanta 30305
404-261-7100
- ATLANTA COMPUTER MART**
5091-B Buford Hwy
Atlanta 30340
404-455-0647
- COMPUTERLAND**
2423 Cobb Parkway
Smyrna 30080
404-953-0406
- THE LOGIC STORE**
3050 Macon Road
Columbus 31906
404-568-0197
- MERCHANT'S BUSINESS MACHINES**
18 Executive Dr. NE
Atlanta 30329
404-633-1027
- PERIMETER OFFICE SUPPLY & EQUIP. INC.**
6950 Peachtree Ind. Blvd., Suite F
Norcross 30071
404-449-5832
- HAWAII**
- COMPUTERLAND**
567 S. King St.
Honolulu 96813
808-521-8002
- IDAHO**
- ELECTRONIC SPECIALTIES**
8411 Fairview Ave.
Boise 83704
208-376-5040
- WORLD TOY & HOBBY CRAFT**
7820 Fairview Ave.
Boise 83704
208-376-3561
- ILLINOIS**
- APPLETREE STEREO**
1022 W. Lincoln Hwy
DeKalb 60115
815-758-2442
- APPLETREE STEREO**
117-119 E. Beaufort St.
Normal 61761
309-452-4215
- APPLETREE STEREO**
1645 N. Alpine
Rockford 61107
815-226-9826
- ARPHAX CORPORATION**
1422 N. E. Adams
Peoria 61603
309-676-1047
- BLACKHAWK OFFICE SUPPLIES**
420 First St.
Dixon 61021
815-288-3311
- BYTE SHOP**
1602 S. Neil St.
Champaign 61820
217-352-2323
- BYTE SHOP**
5 S. LaGrange Road
LaGrange 60525
312-579-0920
- BYTE SHOP**
3361 W. Dempster St.
Skokie 60076
312-673-3550
- CHICAGO SYSTEMS, INC.**
2200 Lawrence Ave.
Chicago 60625
312-561-6137
- COMPUTERLAND**
50 E. Rand Rd.
Arlington Heights 60004
312-255-6488
- COMPUTERLAND**
136 W. Ogden Ave.
Downers Grove 60515
312-964-7762
- COMPUTERLAND**
1500 S. Lake St.
Mundelein 60060
312-949-1300
- COMPUTERLAND**
9511 Milwaukee Ave.
Niles 60648
312-967-1714
- COMPUTERLAND**
10935 S. Cicero Ave.
Oak Lawn 60453
312-422-8080
- COMPUTERLAND**
4507 N. Sterling
Peoria 61614
309-688-6252
- FINANCIAL DYNAMICS**
530 Park Ave.
River Forest 60305
312-771-5441
- KAPPEL'S COMPUTER STORE**
125 E. Main St.
Belleville 62220
618-277-2354
- LILLIPUTE COMPUTER MART**
4446 Oakton St.
Skokie 60076
312-674-1383
- MICROBUS**
6146 N. Lincoln Ave.
Chicago 60645
312-583-8358
- ORCUTT BUSINESS MACHINES**
431 First Street
LaSalle 61301
815-224-2774
- RUHL & ASSOCIATES**
24 W. Stevenson
Freeport 61032
815-235-7800
- SCHAFF SYSTEMS & ENGINEERS**
Rts. 25 & 62
Algonquin 60102
312-658-5013
- STEREOTRONIC INDUSTRIES**
Wadsworth Rd. & North Ave.
Zion 60099
312-336-2222
- SYSTEMS, INC.**
2200 W. Lawrence Ave.
Chicago 60625
312-561-6137
- INDIANA**
- AUDIO SPECIALISTS**
405 N. Michigan
South Bend 46601
219-234-5001
- COMMUNICATIONS ELECTRONICS**
2204 Grand Ave.
Connersville 47331
317-825-6893
- THE COMPUTER CENTER**
51591 U.S. 31 North
South Bend 46637
219-277-4655
- COMPUTERLAND**
19 W. 80th Place
Merrillville 46410
219-769-8020
- FT. WAYNE ELECTRONICS**
3606 Maumee Ave.
Ft. Wayne 46803
219-423-3422
- GRAHAM ELECTRONIC SUPPLY**
23rd and Columbia
Anderson 46014
317-644-3381
- GRAHAM ELECTRONIC SUPPLY**
133 S. Pennsylvania St.
Indianapolis 46204
317-634-8202
- GRAHAM ELECTRONIC SUPPLY**
408 North Street
Lafayette 47902
317-423-5564
- STEWART BUSINESS MACHINES**
4778 Broadway
Gary 46408
219-884-9474
- IOWA**
- THE COMPUTER CENTER**
302 Commercial
Waterloo 50701
319-232-9504
- CYBERIA, INC.**
2330 Lincoln Way
Ames 50010
515-292-7634
- THE MEMORY BANK**
4128 Brady St.
Davenport 52806
319-386-3330
- KANSAS**
- CENTRAL KANSAS OFFICE SYS**
234 W. 4th St.,
Hutchinson 67501
316-662-0513
- COMPUTERLAND**
10049 Santa Fe Drive
Overland Park 66212
913-492-8882
- COMPUTER SYSTEMS DESIGN**
906 N. Main
Wichita 67214
316-265-1120
- COMPUTER VIDEO ROOM**
7105 W. 105th St.
Overland Park 66212
913-648-7105
- MAIN ELECTRONICS**
225 Ida
Wichita 67211
316-267-3581
- PERSONAL COMPUTING CENTER**
3819 W. 95th St.
Overland Park 66212
913-649-5942
- KENTUCKY**
- BARNEY MILLER'S INC.**
232 E. Main St.
Lexington 40507
606-252-2216
- COMPUTERLAND**
10414 Shelbyville Rd.
Louisville 40223
502-245-8288
- MICROTECH, INC.**
1127 S. 6th St.
Louisville 40203
502-587-8099
- LOUISIANA**
- COMPUTER PLACE**
3340 Highland Road
Baton Rouge 70812
504-387-0072
- COMPUTER PLACE**
1904 Pinook Rd. # 202
Lafayette 70508
318-232-4097
- COMPUTER SHOPPE**
12-A W. Bank Expressway
Gretna 70053
504-366-0687
- COMPUTER SHOPPE**
3225 Danny Park
Metairie 70002
504-454-6600
- EXPANDED TECHNOLOGIES, INC.**
3883 Greenway Place
Shreveport 71105
318-868-5144
- FREEMAN ELECTRONICS**
708 N. 7th St.
West Monroe 71291
318-388-2312
- VIDEO SPECTRIUM**
6601 Veterans Memorial Blvd.
Metairie 70003
504-885-6527
- MAINE**
- C.N.A.**
37 High St.
Lewiston 04240
207-784-6961
- MARYLAND**
- COMPUTERLAND**
16065 Frederick Road
Rockville 20855
301-948-7676
- COMPUTERS, ETC.**
13-A Allegheny Ave.
Towson 21204
301-296-0520
- MAC'S MERCHANDISE MART**
7140 Fairbrook Rd.
Baltimore 21207
301-298-0473
- THE MATH BOX, INC.**
2621 University Blvd. W.
Wheaton 20902
301-933-8770
- YOUR OWN COMPUTER, LTD.**
10678 Campus Way South
Largo 20870
301-350-6680
- MASSACHUSETTS**
- COMPUTART CORP.**
270 Third St.
Cambridge 02142
617-491-2700
- COMPUTER CITY**
5 Dexter Row
Charleston 02129
617-242-3350
- COMPUTERLAND**
214 Worcester St.
Wellesley 02181
617-235-6252
- COMPUTER SHOP 11000011**
288 Norfolk St.
Cambridge 02139
617-661-2670
- COMPUTER VILLAGE**
65 Myron St.
West Springfield 01089
413-739-3809

* Denotes dealer buying directly from Commodore



Authorized Dealers

- * NEECO (New England Electronics)
679 Highland Ave.
Needham 02192
617-449-1760
- * RETAIL COMPUTER CENTER
455 Center St.
Ludlow 01056
413-589-0106
THE SOUND COMPANY
Fairfield Mall
Chicopee 01020
413-593-5330
THE SOUND COMPANY
447 Sumner Avenue
Springfield 01108
413-736-3626
THE SOUND COMPANY
The Westfield Shops
423 E. Main St.
Westfield 01085
413-568-1160
- MICHIGAN**
THE COMPUTER CENTER
28251 Ford Rd.
Garden City 48135
313-422-2570
* COMPUTER HOUSE
1407 Clinton Road
Jackson 49202
517-783-5343
COMPUTERLAND
2927 28th St. SE
Kentwood 49508
616-942-2931
COMPUTERLAND
301 S. Livernois
Rochester 48063
313-652-9000
COMPUTERLAND
29673 Northwestern Hwy
Southfield 48034
313-356-8111
* COMPUTERMART OF ROYAL OAK
560 W. 14 Mile Road
Clawson 48017
313-288-0040
* COMPUTRONIX
423 Saginaw Rd.
Midland 48640
517-631-8060
HILTON FROST, INC.
162 Apple Ave.
Muskegon 49442
616-722-6757
INTERLINK
101 North Maplewood
Berrin Springs 49103
616-471-2144
616-471-3126
* MAIN SYSTEMS, INC.
1161 N. Ballenger Hwy # 8
Flint 48504
313-232-3130
MAIN SYSTEMS, INC.
1324 Lake Drive, SE
Grand Rapids 49506
616-454-0298
MAIN SYSTEMS, INC.
2929 Covington Court
Lansing 48912
517-485-3910
MATRIX, INC.
1241 N. Main
Ann Arbor 48104
313-663-6677
NATIONAL MICRO
1094 Third St.
Muskegon 49440
616-722-2929
* NEWMAN COMPUTER EXCHANGE
1250 N. Main Street
Ann Arbor 48107
313-994-3200
- MINNESOTA**
* COMPUTER DEPOT
3615 W. 70th St.
Minneapolis 55436
612-927-5601
* COMPUTER DEPOT
7625 Bush Lake Rd.
Minneapolis 55435
612-831-2088
COMPUTERLAND
8070 Morgan Circle Dr.
Bloomington 55431
612-884-1474
- * DIGITAL DEN
2138 Burnsville Center
Burnsville 55337
612-770-3424
* DIGITAL DEN
1009 Maplewood Mall
Maplewood 55109
612-770-3975
* MINNESOTA MICRO SYSTEMS
514 Cedar Ave. South
Minneapolis 55454
612-338-5604
* SCHAACK ELECTRONICS
1415 Mendota Heights Rd.
St. Paul 55120
612-454-6830
ZIM COMPUTERS
5717 Xeres Ave.
Brooklyn Center 55429
612-560-0336
- MISSISSIPPI**
MISSISSIPPI MICROS INC.
Mart 51-1700 Terry Rd.
Jackson 39204
601-948-7846
- MISSOURI**
* COMPUTER COUNTRY
235 Dunn Road
Florissant 63031
314-921-4433
* COMPUTER COUNTRY
4479 Lemay Ferry Rd.
St. Louis 63129
314-487-2033
* COMPUTER COUNTRY
808 Oliver St.
St. Louis 63101
314-231-1101
COMPUTERLAND
1214 S. Noland Road
Independence 64055
816-461-6502
COMPUTERLAND
11990 Dorset Road
Maryland Heights 63043
314-567-3291
* COMPUTER MART
1915 Noland Road
Independence 64055
816-461-5005
COMPUTER VIDEO ROOM
1811 W. 43rd
Kansas City 64111
816-531-1050
GATEWAY OFFICE MACHINES
9505 Gravois
Affton 63123
314-631-0110
PARSONS ELECTRONICS
1059 Venture Dr.
St. Charles 63301
314-723-2227
- MONTANA**
BYTE SHOP
1201 Grand Ave. Suite 3
Billings 59102
406-252-2299
* THE COMPUTER STORE
1216 16th St. W. # 35
Billings 59102
406-245-0092
- NEBRASKA**
AMERICAN COMPUTERS
4442 S. 84th
Omaha 68127
402-592-1518
COMPUTERLAND
11031 Elm St.
Omaha 68144
402-391-6716
DOUBLE E ELECTRONICS
280 N. 115th St.
Omaha 68154
402-334-7870
* MIDWEST COMPUTER
8625 "I" Street
Omaha 68127
402-592-3590
- NEVADA**
BYTE SHOP
4104 S. Keitzke Lane
Reno 89502
702-826-8080
* HOME COMPUTERS
1775 Tropicana
Las Vegas 89109
702-736-6363
INGENUITY, INC.
1562 Linda Way
Sparks 89431
702-359-6671
SUPER SOUND
1727-C E. Charleston
Las Vegas 89104
702-384-1512
- NEW HAMPSHIRE**
COMPUTERLAND
419 Amherst
Nashua 03060
603-889-5238
L. D. ENTERPRISES
736 Third Ave.
Berlin 03570
603-752-1942
STILLGATE COMPUTER SYSTEMS
1 West Street
Keene 03431
603-357-3981
- NEW JERSEY**
COMPUTERLAND
Highway E65 Route 4
Paramus 07652
201-845-9303
COMPUTERLAND
74 Elm St.
Morristown 07960
201-539-4077
COMPUTERLAND
1442 E. Route 70
Cherry Hill 08034
609-795-5900
* THE COMPUTER NOOK
Pinebrook Plaza, Rt. 46
Pinebrook 07058
201-575-9468
GARDEN STATE COMPUTERS
922 South Avenue
Warfield 07090
201-232-0511
LURI INDUSTRIES
12 Overlook Road
Rochelle Place 07662
201-843-0020
MEDIA SOFTWARE
372 Highcrest Dr.
West Milford 07480
201-682-3341
MELAD ASSOCIATES
P. O. Box 159
Milltown 08850
201-828-3682
S. M. I.
600 Washington Ave.
Carlstadt 07072
201-939-4800
* S.S. COMPUTER ENTERPRISES
224 E. Madison Ave.
Cresskill 07626
201-567-8076
STONEHENGE COMPUTER CO.
89 Summit Avenue
Summit 07901
201-277-1020
THOR ELECTRONICS CORP.
321 Pennsylvania Ave.
Linden 07036
201-486-3300
- NEW MEXICO**
MICROCOMPUTER SERVICES
2201 E. 11th Street
Farmington 84701
505-327-6825
* OMEGA BUSINESS PROD. INC.
3100 Richmond NE
Albuquerque 87107
505-345-4545
- NEW YORK**
AMERICAN PERIPHERALS
3 Bangor Street
Lindenhurst 11747
516-226-5849
* A. S. D. OFFICE SYSTEMS
Van Wyck Plaza
Poughkeepsie 12603
914-473-9400
* ASI CELESTIAL COMPUTERS
N.Y. ASTROLOGY CENTER
127 Madison Avenue
New York City 10016
212-679-5676
* BC COMMUNICATIONS
207 Depot Road
Huntington Stn. 11746
516-549-8833
THE BINARY ORCHARD, INC.
S-5854 Camp Road
Hamburg 14075
716-648-7167
BITS & BYTES
2800 Straight Rd.
Fredonia 14063
716-673-1682
BITS COMPUTERS
418 W. Dominic St.
Rome 13440
315-336-0266
COMPUCIRCUIT
222 E. Amherst St.
Buffalo 14214
716-838-2442
* THE COMPUTER FACTORY
485 Lexington Ave.
New York City 10017
212-687-5001
* COMPUTER GENERAL STORE
103 Atlantic Ave.
Lynbrook 11563
516-887-1500
* COMPUTER HOUSE, INC.
721 Atlantic Ave.
Rochester 14609
716-654-9238
COMPUTERLAND
1612 Niagra Falls Blvd.
Buffalo 14150
716-836-6511
COMPUTERLAND
79 Westbury Ave.
Carle Place Long Island 11514
516-742-2262
* COMPUTER MICROSYSTEMS
1311 Northern Blvd.
Manhasset 11030
516-627-3640
COMPUTER SHOP OF SYRACUSE
3470 E. Erie Blvd.
DeWitt 13214
315-446-1284
* COMPUTER STRATEGIES, INC.
300 N. Main St.
Spring Valley 10977
914-356-7770
COMPUTER WORD, INC.
422 Northern Blvd.
Great Neck 11021
516-487-7830
* COMPUTER WORLD
519 Boston Post Rd.
Port Chester 10573
914-937-6662
COMTEK ELECTRONICS
2666 Coney Island
Brooklyn 11235
212-332-5933
DEJ VIDEO SERVICE, INC.
840 Wellwood Avenue
North Lindenhurst 11757
516-957-8932
EXCEL COMPUTER SERVICES
3636 Holland Ave.
Bronx 10467
212-652-4028
HONDERS COMPUTER EMPORIUM
57 North Street
Middletown 10940
914-343-4880
LOGICAL PLAYBACK
10 Grace Ave.
Great Neck 11021
212-624-9075
* MEIZNER BUSINESS MACHINES
4771 Boston Post Rd.
Pelham 10803
914-738-6000
MR. COMPUTER
Imperial Plaza
Wappingers Falls 12590
914-297-1223
- * JOHN D. OWENS ASSOC.
12 Schubert Ave.
Staten Island 10305
212-448-6283
SECURITY SYSTEMS INSTALLERS
86 Fair Street
Carmel 10512
914-225-5321
UNITED PHOTOCOPIY CO.
41 Union Square
New York City 10003
212-929-4826
* UPSTATE COMPUTER SHOP
629 French Rd., Campus Plaza
New Hartford 13413
315-733-9139
- NORTH CAROLINA**
BYTE SHOP
218 N. Elm St.
Greenboro 27401
919-275-2983
CAROLINA INFORMATION SYSTEMS
1213 Hillsborough St.
Raleigh 27605
919-833-0210
COMPUTERLAND
3915 E. Independence Blvd.
Charlotte 28205
704-536-8500
DATA HELP
2716 Stewart Lane
Rocky Mtn. 27801
919-977-5517
NIBLOCK TYPEWRITER CO.
675 W. 4th Street
Winston Salem 27101
919-722-7013
- OHIO**
ASTRO VIDEO ELECTRONICS
504 E. Main St.
Lancaster 43130
614-687-0629
BYTE SHOP
21162 Lorraine Rd.
Fairfield Park 44126
216-333-3261
* COMP OHO
6500 Busch Blvd.
Columbus 43229
614-436-8442
COMPUTERLAND
6429 Busch Road
Columbus 43229
614-888-2215
COMPUTERLAND
1288 Som Center Rd.
Mayfield Heights 44124
216-461-1200
COMPUTERLAND
4579 Great Northern Blvd.
North Olmsted 44070
216-777-1433
* GRAHAM ELECTRONIC SUPPLY
239 Northland Blvd.
Cincinnati 45215
513-772-1661
* INDUCTIVE COMPONENTS
1200 Ferris Rd.
Amelia 45102
513-752-4731
* McSHANE
123 W. Washington
Medina 44256
216-725-4568
* MICRO MINI COMPUTER WORLD
74 Robinwood Ave.
Columbus 43213
614-235-5813
OMICRON COMPUTER SYSTEMS
873 N. Monroe Drive
Xenia 45385
513-372-1612
RADIO COMMUNICATIONS
1995 Marion-Bucyrus Rd.
Marion 43302
614-382-4126
* UNIVERSAL AMATEUR RADIO
1280 Aida Dr.
Reynoldsburg 43068
614-866-4267

Authorized Dealers

OKLAHOMA

- * AUDIO HORIZONS
3707 E. Frank Phillips
Bartlesville 74003
918-333-7748
- * BRADFORD BROTHERS
507 S. Main
Tulsa 74103
918-584-4558
- COMPUTERLAND
10621 North May Ave.
Oklahoma City 73120
405-755-5200
- COMPUTER SYSTEMS & SOFTWARE
928 N. York # 19
Muskogee 74401
918-667-3161
- * TEL-COM, INC.
727 N. Brauer Ave.
Oklahoma City 73106
405-232-2035

OREGON

- * ANCRONA
1125 NE 82nd Ave.
Portland 97220
503-254-5541
- COMPUTERLAND
12020 SW Main St.
Tigard 97223
503-620-6170
- * COMPUTER PATHWAYS
831 Lancaster Dr. NE
Salem 97301
503-399-0534
- * COMPUTER PATHWAYS UNLTD.
2151 Davcor SE
Salem 97302
503-363-8929

PENNSYLVANIA

- * A. B. COMPUTERS
115 E. Stump Road
Montgomeryville 18936
215-699-8386
- * CARR ELECTRONICS
Main & Reliance
Telford 18969
215-723-3831
- CENTURY SYSTEMS, INC.
5711 Sixth Ave.
Altona 15602
814-946-4361
- * CHIPS 'N' DIP
4820 Anne Lane
Sharpshville 16150
412-962-9682
- THE COMPUTER HOUSE
1000 Greentree Road
Pittsburgh 15220
412-921-1333
- COMPUTERLAND
4644 Carlisle Pike
Mechanicsburg 17055
717-763-1116
- COMPUTERLAND
81 E. Lancaster Ave.
Paoli 19301
215-296-0210

COMPUTERLAND
1457 MacArthur Rd.
Whitehall 18052
215-776-0202

GLOSSER BROS.
Franklin & Locust Sts.
Johnstown 15901
814-536-6633

* MARKETLINE SYSTEMS
2337 Philmont Ave.
Huntingdon Valley 19006
215-947-6670

* MICRO COMPUTER APPLICATIONS
806 Penn Avenue
Sinking Spring 19608
215-670-1300

* MIGHTY BYTE COMPUTER CENTER
537 Easton Rd-Horsham Pl.
Horsham 19044
215-348-4848

PUERTO RICO

* MICRO COMPUTER STORE
1568 Avenue Central
Caparra Terrace, Rio Piedras
Puerto Rico 00921
809-781-0350

SOUTH CAROLINA

BYTE SHOP
1920 Blossom, Box 1544
Columbia 29205
803-771-7824

SOUTH DAKOTA

* COMPUTER PLACE, INC.
419 E. Railroad Ave.
Aberdeen 57401
605-226-2667

ULTRA SYSTEMS
210 East Kemp
Watertown 57201
605-882-2239

TENNESSEE

L. E. SAUNDERS & SON
1418 Church St.
Nashville 37203
615-329-1001

COMMUNICATIONS MARKETING, INC.
2979 Sandbrook Ave.
Memphis 38116
901-332-0242

MICROSYSTEMS, INC.
5100 Poplar Ave.
Memphis 38137
901-685-9400

TEXAS

* ANCRONA
2649 Richmond Ave.
Houston 77098
713-529-3489

APPLICATIONS PLUS
8585 N. Stemmons Fwy.
Suite 1136
Dallas 75247
214-637-5410

BORDER ELECTRONIC SERVICE
P. O. Box 3804
El Paso 79923
915-532-2524

COMPUTERLAND
3300 Anderson Lane
Austin 78757
512-452-5701

COMPUTERLAND
8061 Walnut Hill Ln. # 912
Dallas 75231
214-363-2223

COMPUTERLAND
6439 Westheimer
Houston 77057
713-977-0909

COMPUTERLAND
17647 El Camino Real
Houston 77058
713-488-8153

COMPUTERLAND
1535 Promenade Center
Richardson 75080
214-235-1285

THE COMPUTER SHOP
917 N. Judge Ely Blvd.
Abilene 79601
915-677-4210

COMPUTER SOLUTIONS
5135 Fredericksburg Rd.
San Antonio 78229
512-341-8851

COMPUTER SOLUTIONS
711 Lake Aire
Waco 76710
817-776-7655

DAL WORTH MICRO COMPUTERS
3103 Woodside Dr.
Arlington 76016
817-429-7988

DATA MATRIX
7401 Gulf Freeway, # 107
Houston 77017
713-641-6138

* ECLECTIC SYSTEMS CORP.
P. O. Box 1166
Addison 75001
214-661-1370

FNI SYSTEMS
7407 Brentfield
Dallas 75248

FNS COMPUTER SERVICES, INC.
1911 N. Robison Rd.
Texarkana 75501
214-832-5666

* FOLEY S
1110 Maine
Houston 77023
713-651-7038

MICRO MART
1015 Navarro
San Antonio 78205
512-222-1426

SORT-DATA CORP.
104 S. Texas Ave. Suite A
Bryan 77801
713-822-7080

UTAH

- BYTE SHOP
3616 W. 2100 South
Salt Lake City 84120
801-355-1041
- COMPUTER DATA SYSTEMS
695 E. 1000 North
Logan 84321
801-753-6990
- COMPUTER HUB
5899 S. State
Murray 84107
801-262-5416
- COMPUTERLAND
161 E. 2nd South
Salt Lake City 84111
801-364-4416
- THE COMPUTER WORKS
735 S. State St.
Provo 84601
801-374-0204
- * THE HI-FI SHOP
2236 Washington Blvd.
Ogden 84401
801-621-5244
- * THE HI-FI SHOP
4680 Holladay Blvd.
Salt Lake City 84117
801-277-2629

VIRGINIA

- COMPUTERLAND
8411 Old Courthouse Rd.
Vienna 22180
703-893-0424
- MIKROTRONICS
2864 Hartland Rd.
Falls Church 22043
703-698-5050
- * RMS TECHNOLOGY, INC.
706 Industry Drive
Hampton 23661
804-838-2458
- SCIENTIFIC TRADING, INC.
2990 Telestar Court, # 115
Falls Church 22042
703-573-8787
- * TYSONS COMPUTER EMPORIUM
1984 Chain Bridge Rd.
McLean 22101
703-821-8333

WASHINGTON

- * AMERICAN MERCANTILE CO.
2418 First Avenue South
Seattle 98134
206-624-6141
- COMPUTERLAND
14340 NE 20th
Bellevue 98007
206-746-2070
- COMPUTERLAND
1500 S. 336th St. # 12
Federal Way 98003
206-838-9363

COMPUTERLAND
8791 S. Tacoma Way
Tacoma 98449
206-581-0388

COMPUTER SYSTEMS DESIGN, INC.
1105 W. Lincoln, P. O. Box 735
Yakima 98907
509-453-2956

* MICRO COMPUTER CENTER
11822 NE 8th St.
Bellevue 98005
206-455-3710

* OMEGA NORTHWEST, INC.
839 106th Ave. NE
Bellevue 98004
206-455-1138

* OMEGA NORTHWEST, INC.
5421 196th SW
Lynnwood 98036
206-775-7585

* OMEGA NORTHWEST, INC.
1032 NE 65th
Seattle 98004
206-522-0220

PERSONAL COMPUTERS, INC.
South 104 Freya
Spokane 99202
509-534-3955

PRITCHARD INSURANCE
180 S. Woodland Beach Rd.
Camano Island 98292
800-426-2303

WEST VIRGINIA

WISCONSIN

- BYTE SHOP
6019 W. Layton Ave.
Greenfield 53220
414-281-7004
- * COLORTRON
2111 Lathrop Ave.
Racine 53405
414-637-2003
- COMPUTERLAND
690 S. Whitney Way
Madison 53711
608-273-2020
- COMPUTERLAND
10111 W. Capitol Dr.
Milwaukee 53222
414-466-8990
- * MADISON COMPUTER STORE
1825 Monroe St.
Madison 53711
608-255-5552
- PETTED
4265 W. Loomis Road
P. O. Box 21851
Milwaukee 53221
414-282-4181
- * WYOMING
- COMPUTER CONCEPTS
1104 Logan Ave.
Cheyenne 82001
307-632-9132

* Denotes dealer buying directly from Commodore



District Sales Offices

Western District
2955 N. Airway Avenue
Costa Mesa, California 92626
714-979-6307

Northwest District
3330 Scott Boulevard
Santa Clara, California 95051
408-727-1130

Midwest District
790 Maple Lane
Bensenville, Illinois 60106
312-595-5990

Northeast District
950 Rittenhouse Road
Norristown, Pennsylvania 19401
215-666-7950

South Central District
4350 Beltwood Parkway South
Dallas, Texas 75234
214-387-0006

Southeast District
5360 Snapfinger Woods Drive
Decatur, Georgia 30035
404-987-3311

USA Sales Office

Commodore Business Machines, Inc.
Computer Sales Division
950 Rittenhouse Road
Norristown, Pennsylvania 19401
215-666-7950

COMMODORE BUSINESS MACHINES, INC.

Keeping Up The Payments

Robert Lock

Basically Useful BASIC

Programs furnished by Marvin L. DeJong, School of The Ozarks

I decided to use this highly useful set of programs furnished by Dr. Marvin L. DeJong to illustrate some points to you beginning Atari/Apple/PET Owners. Much of the Basic software we provide in this magazine is easily transferred for use on your own machine, even though it may be presented by a PET owner, an Atari owner, etc. These programs, developed on (I assume) the AIM-65, will run without revision on your Apple, Atari, or PET. Your results will differ slightly, a variation caused by your particular Basic interpreter, but the program code itself is transparent. In future issues, we hope to solicit the help of you readers in maintaining the flow of software for various machines. Thus, when we print an extensive program for PET that one of you sits down and modifies to run on your Apple, please send me a copy (at least the mods), so we can update in a later issue for Apple owners. I'd like to devote a section of the magazine to "listing reruns" if the demand warrants. One option, I suppose, would be to simply cover techniques for conversion, with occasional routines that provide some

```

10 REM PROGRAM 1- CALCULATES THE BALANCE OF
  A LOAN AFTER N PAYMENTS.
20 PRINT "ENTER YOUR CURRENT BALANCE."
30 INPUT BAL0
40 PRINT "ENTER THE NUMBER OF PAYMENTS."
50 INPUT N
60 PRINT "ENTER YOUR MONTHLY PAYMENT."
70 INPUT PMT
80 PRINT "ENTER YOUR ANNUAL INTEREST RATE
  IN PERCENT."
90 INPUT APR
100 I=APR/1200
120 DUMY=BAL0
130 FOR J=1 TO N
140 BAL0=BAL0*(1+I)-PMT
150 NEXT J
160 NT=N*PMT-(DUMY-BAL0)
170 PRINT "YOUR BALANCE AFTER ";N;" PAYMENTS
  IS $";BAL0
180 PRINT "YOU PAID $";NT;" IN INTEREST."
190 END
ENTER YOUR CURRENT BALANCE.
?3000
ENTER THE NUMBER OF PAYMENTS.
?23
ENTER YOUR MONTHLY PAYMENT.
?143.79
ENTER YOUR ANNUAL INTEREST RATE IN PERCENT.
?10.8
YOUR BALANCE AFTER 23 PAYMENTS IS $30.3651184
YOU PAID $337.535119 IN INTEREST.

```

equivalency across machines. Please take the time to note your thoughts on this on the Editor's Feedback card in the center of the magazine. My thanks to Marvin for the programs.

A bit of "editorial license": When I keyed in these programs for reproduction, I tried to preserve their original flavor. You should note that I took the liberty of nudging lines that were too long over into a non-existent continuation line. If you're just starting out, don't try to enter the program that way... you'll have blanks in your output (or worse).

Example: Program 2, Line 60.

My line shows:

```
60 PRINT "ENTER YOUR INTEREST RATE IN
  PERCENT."
```

When you're keying in the program, you should type it like this:

```
60 PRINT "ENTER YOUR INTEREST RATE IN
  PERCENT."(press carriage return)
```

Clear enough?

```

10 REM PROGRAM 2- CALCULATES THE MONTHLY
  PAYMENT TO AMORTIZE A LOAN
20 PRINT "ENTER THE NUMBER OF PAYMENTS."
30 INPUT N
40 PRINT "ENTER THE BALANCE OF THE LOAN."
50 INPUT BAL0
60 PRINT "ENTER YOUR ANNUAL INTEREST RATE IN
  PERCENT."
70 INPUT APR
80 I=APR/1200
90 PMT=BAL0*I*(1/(1-(1+I)^(-N)))
100 PRINT "YOUR PAYMENTS ARE $";PMT
110 NT=N*PMT-BAL0
120 PRINT "YOU PAY $";NT;" IN INTEREST."
130 END

```

```

ENTER THE NUMBER OF PAYMENTS.
?23
ENTER THE BALANCE OF THE LOAN.
?3000
ENTER YOUR ANNUAL INTEREST RATE IN PERCENT.
?10.8
YOUR PAYMENTS ARE $144.984191
YOU PAY $334.636391 IN INTEREST.

```

```

10 REM PROGRAM 3- CALCULATES THE NUMBER OF
  PAYMENTS TO AMORTIZE A LOAN
20 PRINT "ENTER THE CURRENT BALANCE."
30 INPUT BAL0
40 PRINT "ENTER YOUR MONTHLY PAYMENT."
50 INPUT PMT
60 PRINT "ENTER YOUR ANNUAL INTEREST RATE
  IN PERCENT."
70 INPUT APR
80 I=APR/1200
90 N=- (LOG(1-BAL0/PMT*I))/LOG(I+1)
100 PRINT "YOU HAVE ";N;" PAYMENTS TO MAKE."
110 NT=N*PMT-BAL0
120 PRINT "YOU WILL PAY $";NT;" IN INTEREST."
130 END

```

```

?ENTER THE CURRENT BALANCE.
?3000
ENTER YOUR MONTHLY PAYMENT.
?143.79
ENTER YOUR ANNUAL INTEREST RATE IN PERCENT.
?10.8
YOU HAVE 23.2123282 PAYMENTS TO MAKE.
YOU WILL PAY $337.700665 IN INTEREST.

```

“When you have eliminated the impossible, whatever remains, however improbable, must be the truth.” — Sherlock Holmes



**...and
the truth is, Hayden
publishes the finest
software available!**

SARGON II (Spracklens) Winner of the recent European Microchess Tournament. "Buy this program when it becomes available — ... an evaluation routine that enabled it to beat the giants!...unequaled in the end game..." Personal Computing. #03403, TRS-80 Level II; #03404, Apple II; each \$29.95. #03409, Apple II Disk Version, \$34.95.

MAYDAY (Breitenbach)
An exciting and fastmoving airplane flight simulation. It takes concentration, judgment, and agility to avoid crashing. #02601, PET, \$9.95

GRIDIRON: A Microfootball Game (Microflair Associates) Be both offensive and defensive quarterbacks. Includes time-outs, penalties, a complete kicking game, and the two-point conversion used in college football. #03003, TRS-80 Level II, \$12.95.

BIOCURVE (Microflair Associates) Will chart your biorythms against another person's and suggest when you will be in a state of instability and therefore vulnerability. #03103, TRS-80 Level II, \$9.95.

**Available at your
local computer store!**

 **Hayden Book Company, Inc.**
50 Essex Street, Rochelle Park, NJ 07662

COMPLEX MATHEMATICS (Gilder)
8 programs that give the user the ability to perform computations of complex numbers in BASIC rather than in FORTRAN. #01201, PET; #01203, TRS-80 Level II; #01204, Apple II; each \$14.95.

ENGINEERING MATHEMATICS-1 (Gilder)
Contains 8 programs useful to the engineer such as: Integration by Simpson's Rule, Quadratic Equations (covering all 3 root cases), etc. #01301, PET; #01303, TRS-80 Level II; #01304, Apple II; each \$14.95.

GENERAL MATHEMATICS-1 (Gilder)
Provides 15 programs useful to anyone who wishes to improve their math skills and accelerate their computations. #01101, PET; #01103, TRS-80 Level II; #01104, Apple II; **New! #01105, Sorcerer Version; each \$14.95**

CROSSBOW (Breitenbach)
Features a target game, that besides offering hours of fun, teaches fractions in an exciting and competitive environment. Includes 3 levels of display. #02701, PET, \$9.95

SKETCHMODE (Walton) Create computer graphics, modify them, save them, and read them from tape. #03203, TRS-80 Level II \$11.95.

New! MICROCOMPUTER AIDED DESIGN OF ACTIVE FILTERS (Gilder)
8 programs that simplify the design of active filters and will calculate the component values needed for various bandpass, low pass, and notch type filters. #01401, PET; #01403, TRS-80 Level II; #01404, Apple II; each \$16.95.

Or call (201) 843-0550, ext. 307
**TO CHARGE YOUR ORDER TO
Master Charge or BankAmericard!**
Minimum order is \$10.00; customer pays postage and handling.

6502 SOFTWARE DESIGN

Leo J. Scanlon
Rockwell International

Editor's Note: At \$10.50, this 270 page new release from Sams & Co. represents the first move into the 6502 by the Blacksburg group. My thanks to Leo for permission to reprint these interesting first chapter overviews. RCL

WHY THE 6502?

To understand where the 6502 fits in the microprocessor spectrum, a brief look must be taken at the evolution of 8-bit microprocessors. The first 8-bit microprocessor to make a significant impact on the industry was the 8008 produced by Intel Corporation. Fabricated with p-channel metal-oxide semiconductor (PMOS) technology, the 8008 is considered the foremost "first-generation" 8-bit microprocessor. The 8008 was designed with a calculator-like architecture, and had six scratch-pad registers, an internal stack register, and special instructions to perform input and output. In 1973, Intel Corporation introduced a "second-generation," silicongate, NMOS version of the 8008 microprocessor, and called it the 8080.

The 8080 is essentially an improved 8008, with more addressing, more instructions, and faster instruction times. The internal organization is better too, but the overall 8008 is historically the second-generation de facto standard in microprocessors; the circuit that many people think of first when microcomputers are mentioned. Intel Corporation got a head start on the industry with the 8008, and preserved it with the 8080 through the early 1970s. Until Motorola, Inc. introduced the 6800 microprocessor in 1974, Intel Corporation had virtually no competition.

Motorola, Inc. saw the tremendous microprocessor market potential evolving, and decided to make an entry of their own. They had essentially two ways to go: (1) they could challenge Intel Corporation on their own ground, by producing a new and improved 8080 (as Zilog, Inc. did in 1976 with the Z80), or (2) they could ignore that approach and design a more advanced microprocessor. Realizing that it would be extremely difficult to establish a strong market position (not to mention a leading position) by going after Intel Corporation with a "me too" product, Motorola, Inc. decided to challenge with a superior product.

The resulting product, the 6800 microprocessor, was organized along the lines of classic computer architectural concepts, with input and output devices accessed as memory. In the 6800 microprocessor, the load and store instructions used to access memory are the same instructions used to perform input (read) and output (write) operations on peripheral devices.

This technique, called memory-mapped I/O, eliminates the performance bottlenecks that are associated with having to pass all the data handling and manipulation through a working register, as in the register-based architecture of the 8080.

The preceding brief overview was necessary in order to set the stage for introducing our subject microprocessor, the 6502. The 6502 device was designed by eight ex-employees of Motorola who saw that advances in processes, coupled with a few architectural and software changes, could result in a potentially highly marketable 6800-like microprocessor. They joined a calculator-chip company called MOS Technology.

The MOS Technology design team had two objectives in mind for their next-generation¹ microprocessor—low cost and high performance. Since there is a direct correlation between the manufacturing cost and the die size (the size of the piece of silicon that contains the transistors and resistors which make up the microprocessor), they reduced the complexity of the basic 6800 design as much as possible to minimize the amount of silicon required. Other design decisions included eliminating one of the two accumulators in the 6800 and its tri-state address output buffers. They also replaced the 16-bit index register of the 6800 microprocessor with two separate 8-bit index registers, and they discarded some of the lesser-used instructions of the 6800.

The elimination of instructions opened up some instruction-decode space and permitted the designers to provide the 6502 microprocessor with 13 addressing modes, 7 more modes than the 6800 device has. These modes give the 6502 device capabilities that are normally found only in larger computers. Additionally, the design team realized that although computers are binary machines, man is inherently a decimal-thinking animal, so they added a mode-selection instruction and control bit that allows the 6502 microprocessor to operate on either binary or decimal data. This means that the programmer does not have to remember to write in "decimal adjust" instructions after addition or subtraction operations. For electrical efficiency, the design team employed the newer depletion-load technology, which gives the 6502 clean switching characteristics, low-power

NEED MORE ROM ROOM?

The Spacemaker

\$27.00

Now a Product of CGRS Microtech

The Spacemaker family provides expansion ROM capability for owners of new Commodore PETs and CBMs.

The Spacemakers' Present:

Switch Between Your Toolkit and Word Pro II ROM
Add the Computhink Option and switch between
your Toolkit and Computhinks new ROM DOS

Dealers as of

February, 1980

A B Computers
115 E. Stump Rd.
Montgomeryville, PA 18936

Active Business Machines
23 Beta Court
San Ramon, CA 94583
415-837-4421

ACT/Petsoft
Radcliffe House
66-68 Hagley Rd.
Edgbaston, Birmingham
England B16 8PF

American Peripherals
3 Bangor St.
Lindenhurst, N.Y. 11757
516-226-0552

Bits & Bytes
2800 Straight Rd.
Fredonia, NY 14063
716-673-1682

Computer Center of South Bend
51591 US 31 North
South Bend, IN 46637

Computer Factory, Inc.
485 Lexington Ave.
New York, NY 10017
212-687-5001

Computer Innovations, Ltd.
171 Slater St.
Ottawa, Ontario
Canada K1P 5H7

Computer Nook
Rt. 46 Pinebrook Plaza
Pinebrook, NJ 07058
201-575-9468

Computer Specialties
3820 Minton Rd.
Melbourne, FL 32901
305-724-7314

Computer Systems & Software
Bland Office Bldg.
928 N. York - Suite 19
Muskogee, Okla. 74401
918-687-3161

Computershop janal
#12 coursHerbouville
Lyon, France 69004

Conti Electronics
5656 Fraser
Vancouver, British Columbia
Canada V5W 2Z4

Data Equipment Supply
8315 Firestone Blvd.
Downey, CA 90241
213-923-9361

Dialog Computer
5003 Rick Dr.
Santa Rosa, CA 95405
707-538-0643

Future Distribution, Inc.
Trimex Bldg., Rt. 11
Moers, NY 12958

The Hi-Fi Shop
4680 Holladay Blvd.
Salt Lake City, Utah 84117
801-277-2629

Home Computers
1775 E. Tropicana Unit 2
Las Vegas, Nevada 89109
702-736-6363

K-Smith Associates
11 Mast Court
Sacramento, CA 95831

MBC Systems
28 Marlboro St.
Portland, CT 06480

Melad Associates
1 Perry Rd.
E. Brunswick, NJ 08816
201-828-3682

Micro Mini Computer World
74 Robinwood Ave.
Columbus, OH 43213

MiniComp Systems Ltd.
5666 Stanley St.
Halifax, Nova Scotia
Canada B3K 2G1

Mr. Calculator
160 E. El Camino Real
Mt. View, CA 94040
NCE/Compumart
270 Third St.
Cambridge, MA 02142

New England Electronics Co.
679 Highland Ave.
Needham, MA
Orlando Electronic Co.
2356 W. Oak Ridge Rd.
Orlando, FL 32809

PC Computers
10166 San Pablo Ave.
El Cerrito, Ca 94530
415-527-6657

Programmable Electronic Calculators,
Ltd.
1746-48 W. Chapman
Orange, CA 92668
714-978-6587

Television Elect. Dist.
P.O. Box 10525
Johannesburg 2000 South Africa

Tyson's Computer Emporium
1984 Chain Bridge Rd.
McLean, VA 22101
703-821-8333

The Spacemakers' Future:

While it looks as if Commodore's Word Pro III ROM may move to \$A000 (thus avoiding the conflict with the current version of the Toolkit), three U.S. software vendors (that we know of) are currently working on ROM based software packages. Look out conflicts!

Start with Spacemaker as your ROM switching device, and it can grow as your problems do. Spacemaker and its family of optional devices allow you to:

Select one of two ROMs at the same address space...

Use two Spacemakers to select one of each of two pairs of ROMs at adjoining address spaces... (Spacemaker is designed vertically, so you can plug them into empty sockets, side by side!)

Add our software control option and you can Daisy-chain Spacemakers together (with simple little jumpers- the pins you plug into are already built into every Spacemaker) and you can switch select between one of four ROMs at the same address space.

Daisy-chain more and keep selecting...

Don't get left behind in the ROM Race. Spacemaker can grow as your switching problems do. Visit your local dealer to get the full story.

MICROTECH,
the PEDISK Company.

P.O. Box 102
Langhorne, PA 19047
215-757-0284

PET is a trademark of Commodore Business Machines
Spacemaker (formerly a product of Small System
Services, Inc.) is a trademark of CGRS Microtech.
The BASIC Programmer's Toolkit is a trademark of
Palo Alto ICs.

dissipation (250 mW typical for the 6502 versus 600 mW typical for the 6800), and good noise immunity.

The 6502 device is one of 10 software-compatible microprocessors that MOS Technology introduced in 1975 as the 6500 Series. Through second-source agreements, the 6500 Series is also produced by Rockwell International and Synertek. All 10 microprocessors have the same instruction set and the same basic architecture, varying only in size and hardware options. The 6500 Series has been very popular since its introduction, and by the end of 1978, more 6500-Series microprocessors were being shipped than all other 8-bit microprocessors, including the 8080 and 6800.

Today, the best-selling 8-bit microprocessors are divided into two distinct families²—the 8080/Z80 family, with its register-oriented architecture, and the 6500/6800 family, with its memory-mapped architecture. Which architecture will be the more favored in the 1980s? It is impossible to know which at this time, but the manufacturers of the 6800 and 6500 devices are banking solidly on their opinion that the more minicomputer-like architecture holds the greatest potential for advanced circuits. Intel Corporation has not yet shown signs of sharing this opinion, but it may be significant to note that the latest 16-bit microprocessor from Zilog, Inc., the Z8000, represents a solid break with the 8080/Z80 design concept by including memory-mapped I/O.

THE 6502 MICROPROCESSOR

The 6502 microprocessor can be combined with memory and input/output integrated circuits to form a microcomputer. As the "heart" of the microcomputer, the 6502 regulates all operations of the microcomputer, based on the sequence of instructions (the program) that it is executing. The 6502 can execute 56 different types of instructions. The various combinations of addressing that are available for use by individual instruction types give the microprocessor a total of 151 executable instructions. The 6502 instruction set is described in detail in subsequent chapters of this book; for now, let us focus our attention on the internal organization (the architecture) of the 6502 and find out how it operates.

Fig. 1-1 is a block diagram of the internal architecture of the 6502. It shows the elements of the microprocessor and the buses by which they communicate with each other and with external circuits. The 6502 contains most of the control and decision-making logic, so only a few additional circuits are required to configure a small microcomputer system. One of the functions of this additional control logic is to provide the 6502 microprocessor with a clock signal that the internal clock generator will use to generate its two-phase system clock. The 6502 also requires a single +5-volt dc power supply.

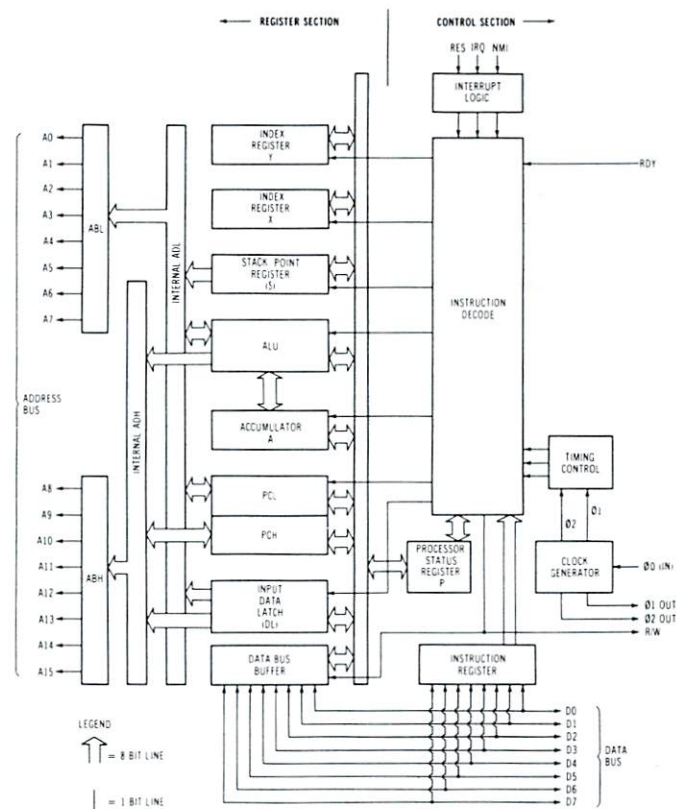

Fig. 1-1. Block diagram of the 6502 microprocessor.

All of the other inputs and outputs of the 6502 integrated circuit are compatible with standard transistor-transistor-logic (TTL).

MACHINE CODE AND ASSEMBLY LANGUAGE

For the 6502 microprocessor to perform a specific task, it must be programmed to do so. A program is nothing more than a sequence of instructions stored in sequential memory locations. The 6502 executes the program, one instruction at a time. It fetches an instruction from memory, decodes it, performs the decoded command, and then fetches the next instruction. This cycle is repeated until all instructions in the program have been executed.

What do these instructions look like? Since the 6502 microprocessor is simply a collection of electronic circuits (albeit in microscopic form), the instructions are composed of binary numbers (1's and 0's) that cause some internal electrical signals to be turned on, others to be turned off. The 6502 is an 8-bit microprocessor, so these binary instructions are comprised of multiples of 8 binary bits.

In early computers, all programming was done in the binary form, normally with switches controlling the individual bits—to set a bit to "1," turn the switch on; to reset a bit to "0," turn the switch off. But a string of 1's and 0's presents such a confusing mess that the computer industry soon realized the need for decimal loaders, which allowed

the instructions to be written in decimal form. Decimal loaders were eventually replaced by hexadecimal loaders, which allowed the instructions to be written in hexadecimal form. Example 1-1 shows both binary and hexadecimal forms of typical program instructions.

Example 1-1. A Typical 6502 Program, in Binary and Hexadecimal Notation

Binary	Hexadecimal
10100101	A5
00100001	21
11000101	C5
00100000	20
10110000	B0
00101011	2B
10100110	A6
00101100	2C

Hexadecimal representation is some help to the programmer because it frees him from using all those error-prone 8-bit binary numbers. Further, hex instructions do not contain quite so many digits in them, making them somewhat easier to memorize. Unfortunately, though, a hexadecimal number gives no hint as to the function of an instruction. Does a "C5" instruction perform an addition, a subtraction, store a value in memory, or none of these? Even when using hexadecimal numbers, it is still difficult to program the 6502 microprocessor. Before you enter a hexadecimal number into the microcomputer, you would first have to find the instructions, that you want to store in the memory of the 6502, on a list provided by the microcomputer manufacturer. The appropriate hexadecimal number (op code) can then be found next to the instruction. The time spent in looking up the instructions and op codes could be very costly in developing a program, not to mention the possibilities of errors.

The next higher level of programming permits the programmer to write instructions in an abbreviated form, something closer to a human language, using abbreviations called mnemonics that can be correlated directly to the function of the instruction. A computer program can then be executed so that these mnemonics are actually converted to the sequence of 1's and 0's that the 6502 can execute. The program that converts these abbreviations into machine code (1's and 0's) is called an assembler, so this form of programming is called assembly language programming. An instruction that increments the X register by one has a hexadecimal form of E8 and an assembly language mnemonic of INX. Which do you think is easier to remember? Table 1-1 lists the assembly language mnemonics for several 6502 instructions.

How does the assembler translate instruction mnemonics to binary codes that the 6502 can execute? The assembler contains a large table

(the permanent symbol table) that contains all the mnemonics (represented by strings of ASCII characters) and their binary equivalents. The assembler compares the mnemonic in your program (a string of ASCII characters) to each ASCII character string in the permanent symbol table. When a "match" occurs, the assembler fetches the binary code associated with the mnemonic, and uses this value during the assembly process. Therefore, the assembler translates the mnemonic INX (Increment X by 1) to E8, and the mnemonic CLC (Clear Carry flag) to 18. In this book, all example programs will be written using the standard mnemonics;

Table 1-1. Some 6502 Mnemonics

Mnemonic	Instruction
ADC	Add memory to accumulator with Carry
CLC	Clear Carry flag
INX	Increment index X by 1
LDA	Load accumulator with memory
TAX	Transfer accumulator to index X

these are the mnemonics that are defined in the literature of the manufacturers. ©

PET' MACHINE LANGUAGE GUIDE

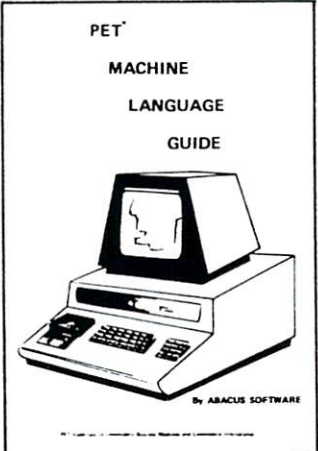

PET'
MACHINE
LANGUAGE
GUIDE

By ABACUS SOFTWARE

Contents include sections on:

- Input and output routines.
- Fixed point, floating point, and Ascii number conversion.
- Clocks and timers.
- Built-in arithmetic functions.
- Programming hints and suggestions.
- Many sample programs.

If you are interested in or are already into machine language programming on the PET, then this invaluable guide is for you. More than 30 of the PET's built-in routines are fully detailed so that the reader can immediately put them to good use.

Available for \$6.95 + .75 postage. Michigan residents please include 4% state sales tax. VISA and Mastercharge cards accepted - give card number and expiration date. Quantity discounts are available.

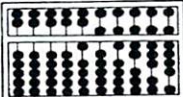

ABACUS SOFTWARE
P. O. Box 7211
Grand Rapids, Michigan 49510

THANKS FOR THE MEMORIES.

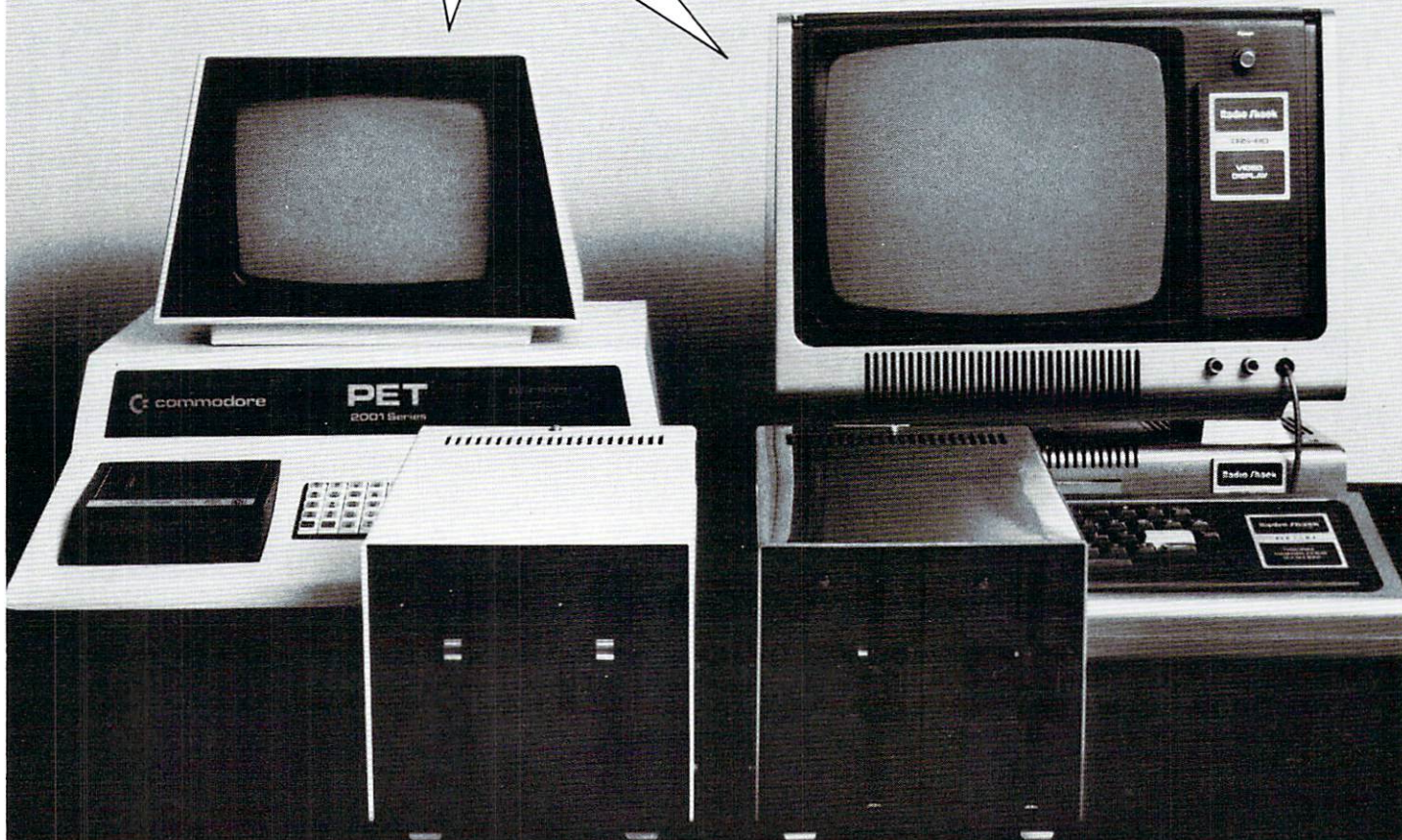

Thanks to these inexpensive Pet and TRS-80 memories and disk drives you can instantly increase your personal computer's capacity, capability and versatility.

Expand your Pet.

Disk Drives: Choose either double density 400k or dual head double density 800k on-line disk drive. Both with DOS operating system including 17 additional BASIC commands and random or indexed sequential access.

Exceptionally fast 5,000 bytes per second (including verify) transfer speed lets you load 20k program in just 3 seconds. Model 8k must have Expandamem™ to operate disk drives. All other models are plug compatible.

400k only \$1295. 800k only \$1695.

Expandamem™: Lets you expand the size and scope of your programs. 16k, 24k, and 32k internal memory boards give you 8k of assembly language subroutines accessed via the USR command.

16k only \$425. 24k only \$525. 32k only \$615.

Software: Complete library available. Write for details.

Expand your TRS-80.

Disk Drive: Single density dual head 400k on-line disk drive is completely compatible with TRS-80 DOS and uses own controller. Only \$1295.

IMMEDIATE DELIVERY! ORDER TODAY!

COMPUTHINK

965 W Maude, Sunnyvale, CA 94086.
(408) 245-4033.

Please send me the following:

- Pet Disk Drive 400k 800k
- Pet Expandamem™ 16k 24k 32k
- Pet Software (Info only)
- TRS-80 400k Disk Drive
- Name of my nearest Computhink dealer

Total enclosed: \$ _____

Check or Money Order only Calif. Res. add 6% tax.
Freight pre-paid in continental U.S.

Dealer Inquiries Invited.

Name _____

Address _____

City _____ State _____ Zip _____

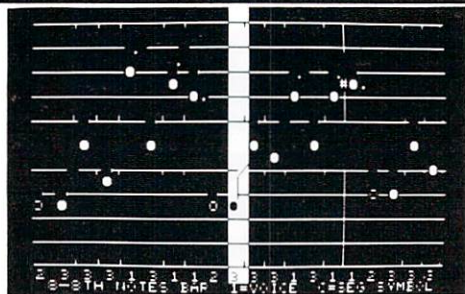

FOUR PART HARMONY FOR THE PET

A-B Computers announces a combination system consisting of the KL-4M DAC Board and the Visible Music Monitor for Commodore PET-CBM computers. The package enables PET users to easily create and play musical compositions of up to 4 parts.

The KL-4M Board includes an 8-bit Digital to Analog Converter, a low pass filter to eliminate high frequency computer generated hiss, and an on-board audio amplifier. An RCA-type jack is also included for quick attachment of your speaker. Amplification of the 6522 CB2 generated single note sound is incorporated as well, so that no additional hardware (other than a speaker) is required. Connection is made via the parallel and cassette ports. Both ports are extended with duplicate connectors (with keyways) so I/O capabilities are not reduced in any way. Board orientation is parallel to the back of the PET so additional table space is not required. The KL-4M is compatible with any of the 4 part music monitors, for which a number of precoded songs are available.

The visible Music Monitor is intended to support 4-part harmony systems such as the KL-4M. Visible Music Monitor is written entirely in 6502 machine language. VMM provides an easy way to enter 4-part music. The user can see the notes on the screen as they are entered, and can make changes both with the insert and delete keys, and by using cursor up and down to "move" notes on the screen. Other features include "record changer" mode to load successive songs without intervention, user definable keyboard, and entry of whole notes through 64ths including dotted and triplet notes. Additionally, you can specify or change tempo, set key signature, and transpose at any time. Wave form modification makes it possible to create new instrument sounds. Voices can switch from one instrument to another or gang up on one instrument during the course of the song. Music can be played either with note display (useful for debugging songs), or with no display.

KL-4M Music Board & Visible Music Monitor Program \$59.90

PAPER-MATE 60 COMMAND WORD PROCESSOR



by Michael Riley

Paper-Mate is a full-featured word processor for \$29.00 by Michael Riley. Paper-Mate incorporates 60 commands to give you full screen editing with graphics for all 16k or 32K PETs, all printers, and disk or tape drives. It also includes most features of the CBM WordPro III, plus many additional features.

For writing text, Paper-Mate has a definable keyboard so you can use either Business or Graphics machines. Shift lock on letters only, or use keyboard shift lock. All keys repeat.

Paper-Mate text editing includes floating cursor, scroll up or down, page forward or back, and repeating insert and delete keys. Text Block handling includes transfer, delete, append, save, load, and insert.

All formatting commands are imbedded in text for complete control. Commands include margin control and release, column adjust, 9 tab settings, variable line spacing, justify text, center text, and auto print form letter (variable block). Files can be linked so that one command prints an entire manuscript. Auto page, page headers, page numbers, pause at end of page, and hyphenation pauses are included.

Unlike most word processors, PET graphics as well as text can be used. Paper-Mate can send any ASCII code over any secondary address to any printer.

Paper-Mate works on 16K or 32K PETs with any ROM, cassette or disk, and CBM or non-CBM printers. An 8K version is in the planning.

To order Paper-Mate, specify machine and ROM type.

On Tape (with manual): \$29.95
On Disk (with manual): \$32.95
Manual Separate: \$ 1.00

BET YOU CAN'T BEAT IT! MICROHELLO

by Mike Riley

There are five levels of play in this PET machine language program. Level four is for experts only and is designed for tournament level play. So far no one has been able to beat level four. Level five takes several minutes to move and is used for exhaustive analysis of specific moves.

There are several features to help in the analysis of a game. Any position on the board can be recalled and replayed. Both the level of difficulty and the position of the pieces can be changed at any time. You can play against the machine, against another person, or watch the machine play itself. You and the machine can switch sides during the game. Moves are selected with the cursor rather than by coordinates.

For all PETS: \$9.95

TUNNEL VISION & KAT AND MOUSE NOW IN MACHINE LANGUAGE

By Riley and Levinson

This program was so popular that several other versions have appeared on the market. In order to keep ahead of the competition, the program has been re-written in machine language for fast graphics.

The program includes two excellent maze games. In Tunnel Vision, you view the maze from inside in perspective. If you get lost, the program provides a map showing your trail. In Kat and Mouse, you must find your way through the maze before the hungry Kat finds you. Each maze has only one solution, and each is unique.

For all PETS: \$7.95



FREE! Up to \$170 in merchandise with purchase of one of following PET-CBM items !!!

Axiom EX-801 PET Printer (with graphics) \$ 475.00
Axiom EX-820 PET Plotter \$ 749.00
Anderson Jacobson 841 Selectric \$1015.00
Leedex Video 100 12" Monitor \$ 119.00
Heath WH19 Terminal (factory asm.) ... \$ 770.00
Heath WH14 Printer (factory asm.) ... \$ 735.00
IEEE-RS 232 Printer Adaptor for PET ... \$ 88.00

BETSI PET to S-100 Interface \$ 119.00
PET Connectors-Parallel or IEEE \$ 1.95
Cassette Port \$ 1.45
Hands on Basic with a PET \$ 10.15
Programming the 6502 (Zaks) \$ 10.45
6502 Applications Book (Zaks) \$ 10.45
6500 Manuals (MOS Technology) \$ 6.50
Programming a Microcomputer: 6502 .. \$ 7.75
6502 Assembly Language
(Osborne) NEW! \$ 9.90

KIM-1 \$159 (add \$30 for power supply) SYM-1 \$209
BAS-1 Microsoft ROM Basic for SYM \$ 85
Memory Plus (KIM, SYM, AIM) \$195
SYM Assembler in ROM \$ 85
KIM 16K Static RAM \$284
Seawell Motherboard - 4K RAM Space ... \$139
KTM-2/80 Synertek Video Board \$349
S-100 16K Static RAM Kit **SALE** \$198
TIS PET Workbooks - set of 6 \$ 21.50
Dust Cover for PET \$ 7.45

All Book and Software Prices are Discounted
PET Personal Computer Guide (Osborne) ... \$ 12.75
PET and the IEEE-488 Bus (Osborne) \$ 12.75
6502 Software Cookbook (Scelbi) \$ 9.45
Cassettes (all tapes guaranteed) AGFA PE611
Premium quality, high out put low noise in 5 screw
housing with labels:
C-10 10/5.65 50/25.00 100/48.00
C-30 10/6.90 50/30.00 100/57.00

PET SPECIALS

*FREE

PET 16N 16K full size graphics keyboard \$ 995 **\$130**
PET 16B 16K full size business keyboard \$ 995 **\$130**
PET 32N 32K full size graphics keyboard \$1295 **\$170**
PET 32B 32K full size business keyboard \$1295 **\$170**
PET 8N 8K full size graphics keyboard \$ 795 **\$100**
PET 2040 DUAL DISK DRIVE-343,000 bytes \$1295 **\$170**
PET 2022 Tractor Feed Printer \$ 795 **\$100**
PET 2023 Pressure Feed Printer \$ 695 **\$ 70**
PET C2N External Cassette Deck \$ 95 **\$ 12**
Used 8K PETs (limited quantities) \$ 495

★ **EDUCATIONAL DISCOUNTS** ★
Buy 2 PET Computers, get 1 FREE

*Free Merchandise with Purchase of PET-CBM Item.

2716 EPROM (5 volt) \$29.00 5 @ 27.00 10 @ 25.00
4116 RAM 16K x 1 \$7.50 8 @ 7.10
2114 L 450 \$5.35 20 @ 4.95 80 @ 4.45
2114 L 300 \$6.10 20 @ 5.65 80 @ 5.05
6502 \$8.35 10 @ 7.85 40 @ 7.35
6522 \$7.15 10 @ 6.95 40 @ 6.45
6520 \$5.15 10 @ 4.90 40 @ 4.45
6532 \$7.90 10 @ 7.40 40 @ 6.85
6502A \$9.50
6504 \$7.95
21L02 \$ 90
6550 RAM (PET 8K) \$12.70
S-100 Wire Wrap \$2.85 10 @ 2.65
S-100 Solder Tail \$2.35 10 @ 2.15

ATARI - INTRODUCTORY SPECIAL

ATARI 400, Atari 800 and all Atari Modules 20% OFF.

Programmers Toolkit - PET ROM Utilities \$ 44.90
Sargon II (TRS-80 or Apple) NEW! \$ 24.90
Microchess for PET (Peter Jennings) \$ 17.90
Visible Music Monitor (4 Voice) for PET \$ 29.90
KL-4M 4 Voice Music Board (PET) \$ 34.90
CmC Word Processor (8K \$25) (16K \$34)
Adventures by Scott Adams 15% Off

SALE

(write for quantity prices)



Scotch 8" Disks 10/\$31.00
Scotch 5 1/4" Disks 10/\$31.50
Verbatim 5 1/4" Disks 10/\$26.50
Diskette Storage Pages 10/\$ 3.95
Disk Library Cases 8" - \$2.95 5" - \$2.15
BASF 5 1/4" Disks 10/\$28.00
BASF 8" Disks 10/\$29.00



MINIMAX by COMPU/THINK

MINIMAX I (8 Megabyte Disks) \$3395
MINIMAX II (24 Megabyte Disks) \$4495

SPECIAL - MINIMAX prices include Compu/

Think PAGEMATE Database and Report Writer at no charge.

115 E. Stump Road
Montgomeryville, PA 18936

(215) 699-8386
699-5826

A B Computers

WRITE FOR COMPLETE CATALOG

Add \$1.00 per order for shipping.
We pay balance of UPS surface charges on all prepaid orders.

COMPUTERS Boring, Boring, Boring

**Ron Kushnier
25 Wendy Way
Richboro, PA 18954**

Sure, everyone knows how exciting it is to play Space Invaders or some similar game on their home computer!

But perhaps the real utility in our machines is derived from uses that are less dramatic. After all, one of the primary uses for any machine is to free us from the drudgery and mundane routine that burden us in our daily lives; so that we can go off and think lofty thoughts and delve into the esoteric.

Such an application resulted from a problem with the heating system of our new home last winter. I knew that the heating contractor and the builder were less than cooperative and that if I were to get anywhere with them I would have to produce *cold, hard facts*. I also knew that according to Murphy, on the day they would come to inspect the system, it would be sunny and warm and the heater would exhibit absolutely no sign of improper design or malfunction. I needed data- lots of data to substantiate my claim.

I turned to my Pet. Fortunately at work, I had all the peripherals I needed to turn my computer into a digital recording thermometer. I had previously ordered a DAM system (now called micro Mac) from Conn. MicroComputer Corp. This set of devices is designed to provide an analog-to-digital conversion system which interfaces to the Pet. It came with a Tempsens which has two temperature probes good to within a degree Fahrenheit. As an output device, I used an HP model 5150A Thermal Printer.

The program shown gave me a readout of the time every 15 minutes, the temperature at the floor, and the temperature at the five foot level.

I left the Pet on 24 hours a day over the next several days, annotating the data tapes by hand as required with such things as the date, average outdoor temperature, etc. The time period provided enough diverse weather conditions to manifest a fairly comprehensive variety of heating system problems.

My long rolls of data tapes convinced the builder and heating contractor that I was serious. And my impressive collection of equipment could not be challenged.

The computer's function was boring-sit there hour after hour and print out numbers. This certainly could not compare with shooting down a Klingon. Yet, it provided my family and I with a needed and useful utility for which there was no substitute.

Program Listing

```

5 PRINT"ñ
10 OPEN4,4
15 INPUT"HR,MN,SC";HR$,MN$,SC$
17 PRINT"ñ
20 TI$=HR$+MN$+SC$
30 M$=MID$(TI$,3,2)
31 PRINT"ñ
32 PRINT"TIME";"      5 FEET";"      ñ
      -FLOOR"
33 GOSUB500
35 PRINT"ñ";TI$,HIGH,LOW
36 IFF$=M$THEN GOTO30
40 IFM$="00"ORM$="15"ORM$="30"ORM$="45" ñ
      -THEN F$=M$:GOTO90
50 GOTO30
90 GOSUB500
130 PRINT#4,TI$,HIGH,LOW
135 GOTO30
500 POKE59426,0: POKE59426,255: ñ
      -HIGH=PEEK(59471)-20
510 POKE59426,1: POKE59426,255: ñ
      -LOW=PEEK(59471)-20
520 RETURN
59468 ,12
  
```

©

NEW !!

Programs for Commodore's PET®

- **Business Research** **\$50**
Make better decisions with this high power MBA business tool. 16k.
- **Home & Small Business** **\$15-\$40**
● Addresser. ● Inventory
● Shopper ● Dinner's On!
Each has a built-in printer option.
- **Games & Simulations** **\$15ea.**
● Fur Trapper ● High Seas
● Mansion! ● Pentagon! ● Museum!
- **Education Pack** **\$15**
High School sampler with geometry, algebra & chemistry.

Send for full catalog!



HARRY H. BRILEY

P.O. Box 2913
Livermore, CA 94550
(415) 455-9139

MICROCOMPUTER MEASUREMENT and

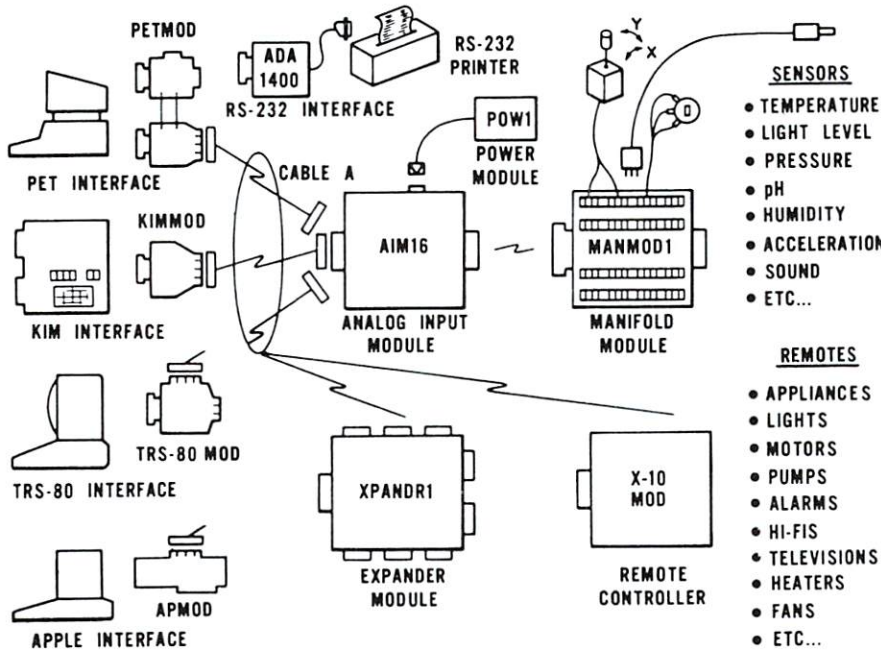

The world we live in is full of variables we want to measure. These include weight, temperature, pressure, humidity, speed and fluid level. These variables are continuous and their values may be represented by a voltage. This voltage is the analog of the physical variable. A device which converts a physical, mechanical or chemical quantity to a voltage is called a sensor.

Computers do not understand voltages: They understand bits. Bits are digital signals. A device which converts voltages to bits is an analog-to-digital converter.

Our AIM 16 (Analog Input Module) is a 16 input analog-to-digital converter.

The goal of Connecticut microComputer in designing the uMAC SYSTEMS is to produce easy to use, low cost data acquisition and control modules for small computers. These acquisition and control modules will include digital input sensing (e.g. switches), analog input sensing (e.g. temperature, humidity), digital output control (e.g. lamps, motors, alarms), and analog output control (e.g. X-Y plotters, or oscilloscopes).

Analog Input Module

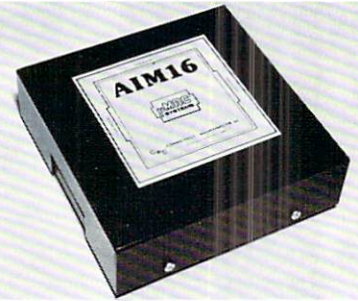

The AIM 16 is a 16 channel analog to digital converter designed to work with most microcomputers. The AIM16 is connected to the host computer through the computer's 8 bit input port and 8 bit output port, or through one of the uMAC SYSTEMS special interfaces.

The input voltage range is 0 to 5.12 volts. The input voltage is converted to a count between 0 and 255 (00 and FF hex). Resolution is 20 millivolts per count. Accuracy is 0.5% ± 1 bit. Conversion time is less than 100 microseconds per channel. All 16 channels can be scanned in less than 1.5 milliseconds.

Power requirements are 12 volts DC at 60 ma.

The POW1 is the power module for the AIM16. One POW1 supplies enough power for one AIM16, one MANMOD1, sixteen sensors, one XPANDR1 and one computer interface. The POW1 comes in an American version (POW1a) for 110 VAC and in a European version (POW1e) for 230 VAC.

Connectors

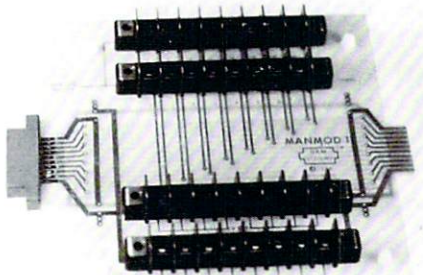

The AIM 16 requires connections to its input port (analog inputs) and its output port (computer interface). The ICON (Input CONnector) is a 20 pin, solder eyelet, edge connector for connecting inputs to each of the AIM16's 16 channels. The OCON (Output CONnector) is a 20 pin, solder eyelet edge connector for connecting the computer's input and output ports to the AIM16.

The MANMOD1 (MANifold MODule) replaces the ICON. It has screw terminals and barrier strips for all 16 inputs for connecting pots, joysticks, voltage sources, etc.

CABLE A24 (24 inch interconnect cable) has an interface connector on one end and an OCON equivalent on the other. This cable provides connections between the uMACSYSTEMS computer interfaces and the AIM 16 or XPANDR1 and between the XPANDR1 and up to eight AIM 16s.

TEMPSENS

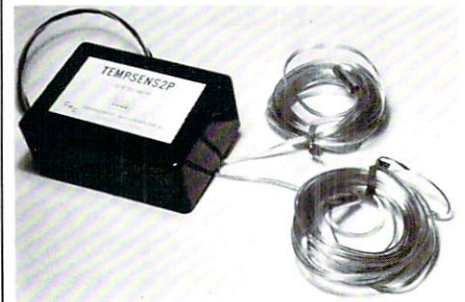

This module provides two temperature probes for use by the AIM16. This module should be used with the MANMOD1 for ease of hookup. The MANMOD1 will support up to 16 probes (eight TEMPSENS modules).

Resolution for each probe is 1°F.

XPANDR1

The XPANDR1 allows up to eight Input/Output modules to be connected to a computer at one time. The XPANDR1 is connected to the computer in place of the AIM16. Up to eight AIM16 modules are then connected to each of the eight ports provided using a CABLE A24 for each module. Power for the XPANDR1 is derived from the AIM16 connected to the first port.

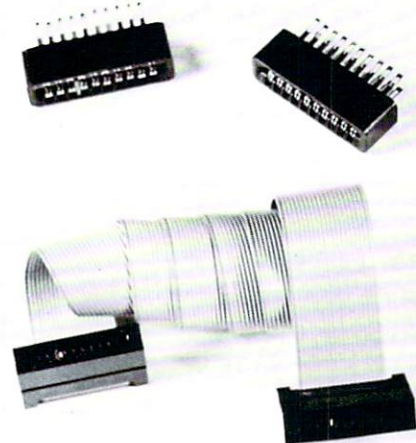
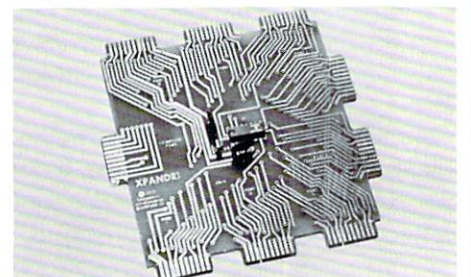

CONTROL for PET, Apple, KIM, and AIM



Computer Interfaces and Sets

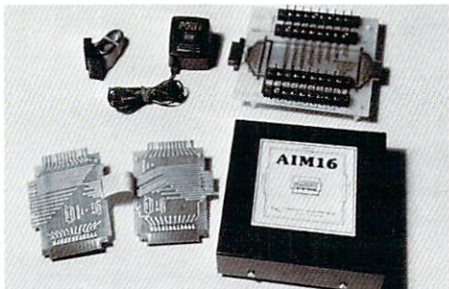

For your convenience the AIM16 comes as part of a number of sets. The minimum configuration for a usable system is the AIM16, one POW1, one ICON and one OCON. The AIM16 Starter Set 2 includes a MANMOD1 in place of the ICON. Both of these sets require that you have a hardware knowledge of your computer and of computer interfacing.

For simple plug compatible systems we also offer computer interfaces and sets for several home computers.

INTRODUCING SUPER X-10 MODULE

Open a door or window and turn on a light, tape recorder, alarm!

Control lab equipment. CLOSE THE LOOP on the real world.

AN INEXPENSIVE CONTROL SOLUTION FOR

HOME SECURITY
ENERGY CONSERVATION
GREENHOUSES
ENVIRONMENTAL CONTROL
INDUSTRIAL CONTROL
LABORATORIES

SUPER X-10 MOD SPECS

- Remote controller**
Controls up to 256 different remote devices by sending signals over the house wiring to remote modules. Uses BSR remote modules available all over the USA (Sears, Radio Shack, etc.). Does not require BSR control module. Does not use sonic link.
- Clock/calendar**
Time of day - hours, minutes, seconds
Date - month, day - automatically corrects for 28,29,30 and 31 day months.
Day of the week.
- Digital inputs/outputs**
8 inputs - TTL levels or switch closures.
Can be used as triggers for stored sequences.
8 outputs - TTL levels



PLUS: CLOCK, CALENDAR,
REMOTE SEQUENCE TRIGGERS



- Computer interfaces**
S-100: Requires one 8-bit input port and one 8-bit output port.
Requires cable assembly.
PET, APPLE, TRS-80, KIM, SYM, AIM65: Plug-in sets available - no cable assembly required.
Other: same as S-100
- Self-contained module in metal case with its own power supply. Physical size approximately 5X6X2.**

Price (until April 30, 1980): \$199.00 (S-100), \$249.00 (other)

All prices and specifications subject to change without notice. Our 30-day money back guarantee applies.

AIM16 (16 channel-8 bit Analog Input Module)	179.00
POW1a (POWER module-110 VAC)	14.95
POW1e (POWER module-230 VAC)	24.95
ICON (Input CONnector)	9.95
OCON (Output CONnector)	9.95
MANMOD1 (MANifold MODule)	59.95
CABLE A24 (24 inch interconnect cable)	19.95
XPANDR1 (allows up to 8 Input or Output modules to be connected to a computer at one time)	59.95
TEMPSENS2P1 (two temperature probes, -10°F to 160°F)	49.95
LIGHTSENS1P1 (light level probe)	59.95

The following sets include one AIM16, one POW1, one OCON and one ICON.
AIM16 Starter Set 1a (110 VAC) 189.00
AIM16 Starter Set 1e (230 VAC) 199.00

The following sets include one AIM16, one POW1, one OCON and one MANMOD1.
AIM16 Starter Set 2a (110 VAC) 239.00
AIM16 Starter Set 2e (230 VAC) 249.00

The following modules plug into their respective computers and, when used with a CABLE A24, eliminate the need for custom wiring of the computer interface.
PETMOD (Commodore PET) 49.95
KIMMOD (KIM, SYM, AIM65) 39.95
APMOD (APPLE II) 59.95
TRS-80 MOD (Radio Shack TRS-80) 59.95

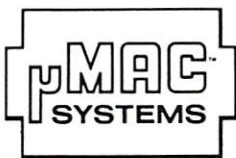

Order Form

CONNECTICUT microCOMPUTER, Inc.
150 POCONO ROAD
BROOKFIELD, CONNECTICUT 06804
TEL: (203) 775-9659 TWX: 710-456-0052

The following sets include one AIM16, one POW1, one MANMOD1, one CABLE A24 and one computer interface module
PETSET1a (Commodore PET - 110 VAC) 295.00
PETSET1e (Commodore PET - 230 VAC) 305.00
KIMSET1a (KIM, SYM, AIM65 - 110 VAC) 285.00
KIMSET1e (KIM, SYM, AIM65 - 230 VAC) 295.00
APSET1a (APPLE II - 110 VAC) 295.00
APSET1e (APPLE II - 230 VAC) 305.00
TRS-80 SET1a (Radio Shack TRS-80 - 110 VAC) 295.00
TRS-80 SET1e (Radio Shack TRS-80 - 230 VAC) 305.00

QUANTITY	DESCRIPTION	PRICE	TOTAL

SUBTOTAL
Handling and shipping — add per order \$3.00
Foreign orders add 10% for AIR postage
add 7% sales tax
TOTAL ENCLOSED

NAME _____
COMPANY _____
ADDRESS _____
CITY _____
STATE _____ ZIP _____
VISA M/C Expiration date _____
Card number _____

new from...
HARDSIDE

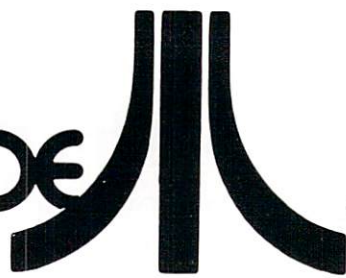

6 SOUTH ST., MILFORD, NH 03055

ATARI®

A Warner Communications Company 



HARDSIDE

TO ORDER TOLL-FREE
1-800-258-1790

(In N.H. call 673-5144)

- ATARI 800 (list 1080.00) 875.00
- ATARI 400 (list 630.00) 515.00
- 810 DISK DRIVE (699.95) 565.00
- 820 40-COLUMN PRINTER
(list 599.95) 470.00
- 410 PROGRAM RECORDER
(list 89.95) 65.00
- JOYSTICK CONTROLLERS . . 18.95
- PADDLE CONTROLLERS . . . 18.95
- ATARI 850 INTERFACE . . to be announced
- ATARI 830 MODEM to be announced
- ATARI 825 PRINTER to be announced

INSIDE ATARI BASIC

Larry Isaacs,
COMPUTE. staff

This article will present information on how the ATARI BASIC stores programs in memory. If you are new to the field of microcomputer programming, this information should help increase your awareness of what your ATARI is doing, making its behavior a little more understandable.

The following information is based solely on what I have been able to observe while working with an ATARI 800. I believe the information to be accurate. However, it is hard to know how complete the information is.

Also for those new to microcomputer programming, the next section gives some preliminary information which should help make the rest of the article more understandable.

PRELIMINARY INFORMATION

One very important term in the field of micro-computing is the term "byte". For purposes of this article, it can be considered a number which can have a value ranging from 0 to 255. The memory in your ATARI consists of groups of bytes, each byte of which can be referenced by a unique address. The part of memory which is changeable, called RAM, starts with a byte at address 0 and continues with bytes at increasing sequential addresses until the top of RAM is reached. The top of RAM is determined by the type and number of memory modules you have in your ATARI.

Bytes, or combinations of bytes, can be used to represent anything you want. Some common uses for bytes include representing memory addresses, characters, numbers, and instructions for the CPU in your ATARI. You will be exposed to several different uses for bytes in this article. Some of these uses will make reference to "two byte binary numbers." This is where two bytes are used to represent a number whose value ranges from 0 to 65535. The decimal value of a two byte binary number can be computed using the formula: **FIRST BYTE + (SECOND BYTE*256)**.

Also in this article, reference will be made to "page zero". Page zero simply refers to the first 256 bytes of memory, i.e. addresses 0 through 255. This part of memory differs from the rest of memory by the fact that these bytes can be referenced using a single byte address. The rest of memory requires two byte addresses.

THE CONVERSION

After typing in a BASIC line, hitting RETURN causes the line to be passed to the programs found in the ATARI BASIC cartridge. Here the line will undergo a certain amount of conversion before it is

stored in memory. One part of this conversion involves converting all of the BASIC reserved words and symbols to a one byte number called a **token**.

Another part of the conversion involves replacing each variable name in the line with an assigned number which will range from 128 to 255. If a variable name has been previously used, it will be replaced by the number previously assigned. If it hasn't been used before, it will be assigned the lowest unused number, starting with 128 for the first variable name. Also, numbers in the BASIC line must be converted into the form which the ATARI BASIC uses before they can be stored in memory.

After the conversion is finished, the line is stored in memory. If the BASIC line does not have a line number, it will be stored after the last statement of your BASIC program, and executed immediately. If it does contain a line number, the converted line will be inserted in the proper place in your program. After the line has been executed or stored, your ATARI will wait for you to type in another line. Even though the line undergoes this conversion, the order in which the reserved words, variables, and symbols occur in the line isn't changed when it is stored in memory.

THE MEMORY FORMAT FOR A BASIC LINE

Let's begin with the general format of how a BASIC line is stored. Once a BASIC line has been converted and stored, the line number is found in the first two bytes of the memory containing the BASIC line. These bytes form a two byte binary number which has the value of the line number. The value of this number can range from 0 to 32767.

The third byte contains the total number of bytes in this BASIC line. This means you can find the first byte of the next line using the following formula: **ADDRESS OF FIRST BYTE OF NEXT LINE = ADDRESS OF FIRST BYTE OF CURRENT LINE + NUMBER IN THIRD BYTE OF CURRENT LINE**.

The fourth byte contains the number of bytes in the first statement in the line, including the first four bytes. If the BASIC line contained only one statement, the third and fourth bytes will contain the same value. If the line had more than one statement, these bytes will be different.

Next come the bytes which represent the first statement in the line. If there is more than one statement, the next byte following the first statement contains the number of bytes in the first two statements. Naturally, if there is another statement after the second one, the first byte after the end of the second statement contains the number of bytes in the first three statements, etc.

This completes the format of a BASIC line as it is found in memory. Before going on, let's put this information to use in a short program which lists out its own line numbers along with the beginning

address of each line. To do this we must first find out where the first byte of the first line is found. It turns out there is a two byte binary number found in page zero which contains the beginning address of the first line. This number is contained in bytes 136 and 137. Also, we will know when we've reached the end of the program when we find a line number of 32768, which is one more than the maximum allowed by ATARI BASIC. The program to print the line numbers and their beginning addresses is shown in Listing 1.

TOKENS

In order to conserve memory, all of the BASIC reserved words, operators, and various punctuation symbols are converted into a one byte number called a token. This conversion also makes execution simpler and faster. The tokens can be divided into two groups. One group contains the tokens which occur only at the beginning of a BASIC statement, and the other group contains the tokens which occur elsewhere in a BASIC statement.

Let's first take a look at the tokens which occur at the beginning of a BASIC statement. It turns out that all statements will begin with one of these tokens. After some investigation, I found that these tokens will range in value from 0 to 54.

The procedure for listing the tokens is fairly simple, though the actual implementation is a bit more involved than the brief explanation which follows. The idea is to put "1 REM" as the first statement of the program. Then use POKES to change the line number and token of this REM statement. By setting the line number and token to the same number, listing the line will print the token and corresponding BASIC reserved word. Fortunately the programs in the BASIC cartridge which do the listing tolerate the incomplete BASIC statements. The program for displaying these tokens is shown in Listing 2. Notice when you run this program, no reserved word is printed for token 54. This is the invisible LET token which is used for assignment statements which don't begin with LET.

A similar procedure can be used to list the other tokens as well. The main differences are to make the first statement "1 REM A", POKE 54 (the invisible LET token) into the first byte of the statement, and make the changes for the token to the second byte of the statement. The values for the tokens which occur after the beginning of a statement range from 20 to 84. The program for printing these tokens is given in Listing 3.

After running this program, you will notice there is no reserved word or symbol printed for token 22. Token 22 is the terminator token found at the end of each BASIC line, except those whose last statement is a REM or DATA statement. Also, tokens 56 and 57 didn't print a reserved word or symbol. Both of these tokens represent the "(" symbol. The "(" doesn't print because these two tokens are

associated with array names, and the "(" symbol is kept with the associated variable name, as will be seen in the next section.

Of course you noticed that most of the symbols occur more than once. There is a different token for each of the different uses of the symbol. For example, the word "=" has four different tokens. Token 45 calls for an arithmetic assignment operation as in $A = A + 1$. Token 46 calls for a string assignment as in $A\$ = "ABC"$. Token 34 is used in arithmetic testing as in $IF A = 1 THEN STOP$. And finally, token 52 is the same as token 34 except that it's for testing strings.

One more token, found after the ones listed in the previous program: token 14, which indicates a constant is stored in the following 6 bytes.

```

10 REM PROGRAM TO PRINT LINE NUMBERS
20 REM AND THEIR ADDRESSES
30 REM
40 REM GET ADDRESS OF FIRST LINE
50 ADDRESS=PEEK(136)+PEEK(137)*256
60 REM GET THE LINE NUMBER
70 LNUM=PEEK(ADDRESS)+PEEK(ADDRESS+1)*256
80 REM TEST FOR END OF PROGRAM
90 IF LNUM=32768 THEN END
100 REM PRINT LINE NUMBER AND ADDRESS
110 ? "LINE # ";LNUM;
120 ? " STARTS AT ADDRESS ";ADDRESS
130 REM GET ADDRESS OF NEXT LINE
140 ADDRESS=ADDRESS+PEEK(ADDRESS+2)
150 GOTO 70

```

```

1 REM
100 REM PROGRAM TO PRINT THE TOKENS
110 REM WHICH BEGIN BASIC STATEMENTS
120 REM GET BEGINNING OF PROGRAM
130 BASE=PEEK(136)+PEEK(137)*256
140 REM CHANGE STATEMENT TERMINATOR
150 POKE BASE+5,22
160 ? CHR$(125): REM CLEAR SCREEN
170 REM PRINT TOKENS
180 FOR I=0 TO 54
190 REM CHANGE LINE NUMBER AND TOKEN
200 POKE BASE,I:POKE BASE+4,I
210 LIST I: REM PRINT TOKEN
220 REM UNDO LINE FEED IF NEEDED
230 IF I>1 THEN ? CHR$(28);
240 REM CHANGE LEFT MARGIN FOR COLUMNS
250 IF I=19 THEN POKE 82,12:POSITION 12,1
260 IF I=39 THEN POKE 82,24:POSITION 24,1
270 NEXT I
280 REM PUT PROGRAM BACK TO NORMAL
290 POKE BASE,1:POKE BASE+4,0
300 POKE BASE+5,155
310 POKE 82,2:POSITION 2,22

```

```

1 REM A
100 BASE=PEEK(136)+PEEK(137)*256
110 REM CHANGE BEGINNING TOKEN
120 POKE BASE+4,54:POKE BASE+6,22
130 REM PRINT OPERATOR AND FUNCTION TOKENS
140 ? CHR$(125)
150 FOR I=20 TO 84
160 POKE BASE,I:POKE BASE+5,I
170 LIST I
180 REM UNDO LINE FEEDS
190 ? CHR$(28);:IF I=22 THEN ? CHR$(28);
200 IF I=39 THEN POKE82,11:POSITION11,1
210 IF I=59 THEN POKE82,19:POSITION19,1
220 IF I=79 THEN POKE82,28:POSITION28,1
230 NEXT I
240 POKE BASE,1:POKE BASE+4,0
250 POKE BASE+5,65:POKE BASE+6,155
260 POKE 82,2:POSITION 2,22

```

VARIABLE NAMES AND CONSTANTS

As each new variable is encountered, it is assigned a number. These numbers begin with 128 and are assigned sequentially up to 255. Notice these numbers will fit into one byte. Also, as each new variable is encountered, the variable name is added to a variable name list, and 8 bytes of memory are reserved for that variable. In the case of undimensioned variables, these 8 bytes will contain the value of the variable. For strings and arrays, these 8 bytes will contain parameters, with the actual values and characters stored elsewhere.

This method of handling variables has some advantages. One advantage is that it keeps usage to a minimum. The variable name is only stored once, and each time that name is referenced in a BASIC statement, it occupies only one byte in the stored program. Another advantage is that the address where the value for a variable is stored can be computed from the assigned number. This isn't true of the BASIC found in some other microcomputers where values must be searched for.

There are also some disadvantages as well. First, it limits you to 128 different variable names. However, the great majority of programs won't need more than 128 variable names. One other disadvantage is that should a variable name be no longer needed, or accidentally entered due to a typo, there is no quick way to remove that variable from the variable name list and reuse the 8 bytes reserved for it.

Apparently, the only way to get rid of unwanted variables is to LIST the program to cassette or disk. For example, LIST "C will list the program to cassette. Once the program is saved, use the NEW command to clear the old program. Then use the ENTER command to reload the program. For cassette this would be ENTER "C. Using the LIST command saves the program in character form. ENTERing the program then causes each line to be converted again as was done when you first typed it in. Now only the variables found in the program will be placed in the variable name list, and space reserved for their value. Using CSAVE and CLOAD won't do this because these save and load a copy of the memory where the program is stored. Unwanted variables are saved and loaded with the rest of the program.

Constants are stored in the BASIC statements along with the rest of the line. The constant will be preceded by a "14" token as mentioned previously. Explaining how ATARI BASIC represents the numbers used as constants and as variable values will require some explanation about BCD (Binary Coded Decimal) numbers. I will save this information for a later article.

To give an example of using the information in this section, let's take a look at the variable name list. Fortunately bytes 130 and 131 contain the address of the beginning of the variable name

list. The list will consist of a string of characters, each character occupying one byte of memory. To indicate the last character of a name, ATARI BASIC adds 128 to the value representing that character. Since the values representing the characters won't exceed 127, the new value will still fit into one byte. To indicate the end of the list, a 0 is placed in the byte following the last character of the last name. The program which prints the variable name list is given in Listing 4. Notice when you run this program, that the "(" is saved as part of a array name, and the "\$" as part of a string name.

MEMORY ORGANIZATION

Finally, let's look at how the memory storage is organized for a BASIC program. The order in which the various parts of a program are found in memory is shown in Figure 1. The only part whose beginning is fixed is the variable name list which begins at address 2048. The beginning of the other parts will move appropriately, as the program grows. There are addresses in page zero which can be used to find each of the parts shown in Figure 1. These addresses, usually called pointers, are shown in Table I. This table includes the two pointers which were used in the previous programs.

Figure 1. MEMORY ORGANIZATION

Increasing	
Addresses	
????	End of Array Storage Area
????	Beginning of Array Storage Area
????	End of Program
????	Beginning of Program
????	End of Variable Storage Area
????	Beginning of Variable Storage Area
????	End of Variable Name List
2048	Beginning of Variable Name List

TABLE 1

ADDRESSES	NAME	CONTENTS POINT TO
130 & 131	BON	Beginning Of variable Names list
132 & 133	EON	End Of variable Name list
134 & 135	BOV	Beginning Of Variable storage area
136 & 137	BOP	Beginning Of Program
138 & 139	CEL	Beginning Of Currently Executing Line
140 & 141	BOA	Beginning Of Array storage area
142 & 143	EOA	End of Array storage area

```

100 REM PROGRAM TO PRINT THE VARIABLE NAME LIST
110 DIM ARRAYNAME(1), STRINGNAME$(1)
120 REM GET THE BEGINNING OF THE LIST
130 ADDRESS=PEEK(130)+PEEK(131)*256
140 ? CHR$(125);"VARIABLE NAME LIST"
150 REM GET CHARACTER AND TEST FOR END
160 A=PEEK(ADDRESS):IF A=0 THEN END
170 REM PRINT CHARACTER
180 IF A<128 THEN ? CHR$(A);:GOTO 210
190 ? CHR$(A-128)
200 REM GET NEXT ADDRESS AND REPEAT
210 ADDRESS=ADDRESS+1:GOTO 160

```

APPLICATION

For those who are interested in putting this information to use, I will present one example here. I will try to give more examples in future issues of COMPUTE.

At some time you may find it useful to be able to "undimension" some arrays of strings, and reuse the memory for some other arrays and strings. It turns out that the CLR function only clears the variables found between the **BOA** (Beginning Of Variables) pointer and the **BOP** (Beginning Of Program) pointer. By temporarily changing the BOP pointer, we can keep some of the variables from being cleared. The array storage area is cleared by setting the **EOA** (End Of Arrays) pointer equal to the **BOA** (Beginning Of Arrays) pointer. We can save some of the array storage area by temporarily changing the BOA pointer.

The listing for this UNDIMENSION routine is shown in Listing 5. The listing also includes a small demo program to illustrate its use. Note that all of the names of variables which are to be cleared should occur in the program prior to any of the names of variables which are to be saved. This puts the storage for the variables to be cleared at the beginning of the variable storage area. Also note that a dummy string which can be cleared is needed by the UNDIMENSION routine. In your main program, this dummy string should be dimensioned just before dimensioning the strings and arrays

```

1 REM DIMENSION THE DUMMY STRING
2 DIM DUMMY$(1)
3 REM DIMENSION THE ARRAYS AND STRINGS
4 REM WHICH WILL NEED CLEARING
5 DIM A1(1),A2(1)
6 CLR: REM CLEAR THESE VARIABLES
7 N=3: REM N= # OF VARIABLES JUST DIMENSIONED
8 REM INCLUDING DUMMY$
9 REM YOUR PROGRAM MAY BEGIN HERE
100 REM HERE IS AN EXAMPLE OF HOW TO
110 REM USE THE UNDIMENSION ROUTINE
120 DIM TEST$(20):TEST$="I'M STILL HERE"
130 DIM DUMMY$(1),A1(50,10)
140 A1(50,10)=1:? A1(50,10),TEST$
150 REM EXECUTE UNDIMENSION ROUTINE
160 LINE=170:GOTO 1020
170 DIM DUMMY$(1),A2(500)
180 A2(500)=2:? A2(500),TEST$
190 END
200 REM
1000 REM UNDIMENSION ROUTINE
1010 REM SAVE CURRENT POINTER VALUES
1020 S136=PEEK(136):S137=PEEK(137)
1030 S140=PEEK(140):S141=PEEK(141)
1040 REM MOVE END OF VARIABLES
1050 T1=PEEK(134)+8*N:T2=PEEK(135)
1060 IF T1>255 THEN T2=T2+1:T1=T1-256:GOTO 1060
1070 POKE136,T1:POKE137,T2
1080 REM MOVE BEGINNING OF ARRAYS
1090 T2=INT(ADR(DUMMY$)/256)
1100 T1=ADR(DUMMY$)-T2*256
1110 POKE140,T1:POKE141,T2
1120 CLR: REM CLEAR THE ARRAYS
1130 REM RESTORE POINTERS AND RETURN
1140 POKE136,S136:POKE137,S137
1150 POKE140,S140:POKE141,S141
1160 GOTO LINE

```

that you will later clear, as was done in statements 120 and 150. This allows the use of the ADR function to find the end of the array area to be saved.

The reason the UNDIMENSION routine is not executed by a GOSUB is that the return line number is lost in the clearing process. Loop parameters will also be lost, so the routine shouldn't be executed while in a FOR..NEXT loop.

CONCLUSION

Hopefully you found the information in this article understandable, and will find it useful at some point in the future. The information does show that ATARI BASIC is fairly efficient in using memory to store programs. Also, there is very little penalty in memory usage when using long variable names. If you have any questions please send them to COMPUTE. ©

DISK DRIVE WOES? PRINTER INTERACTION? MEMORY LOSS? ERRATIC OPERATION? DON'T BLAME THE SOFTWARE!



ISO-1



ISO-2

Power Line Spikes, Surges & Hash could be the culprit!
Floppies, printers, memory & processor often interact!
Our unique ISOLATORS eliminate equipment interaction
AND curb damaging Power Line Spikes, Surges and Hash.

- *ISOLATOR (ISO-1A) 3 filter isolated 3-prong sockets;
integral Surge/Spike Suppression; 1875 W Maximum load,
1 KW load any socket \$56.95
- *ISOLATOR (ISO-2) 2 filter isolated 3-prong socket banks;
(6 sockets total); integral Spike/Surge Suppression;
1875 W Max load, 1 KW either bank \$56.95
- *SUPER ISOLATOR (ISO-3), similar to ISO-1A
except double filtering & Suppression \$85.95
- *ISOLATOR (ISO-4), similar to ISO-1A except
unit has 6 individually filtered sockets \$96.95
- *ISOLATOR (ISO-5), similar to ISO-2 except
unit has 3 socket banks, 9 sockets total \$79.95
- *CIRCUIT BREAKER, any model (add-CB) Add \$ 7.00
- *CKT BRKR/SWITCH/PILOT any model
(-CBS) Add \$14.00



PHONE ORDERS 1-617-655-1532



171 South Main Street, Natick, Mass. 01760

Dept. 2C

JOIN RAYGAMCO NOW!

Become a member of RAYGAMCO Computer Discount Club.



BIG SAVINGS ON EVERY ITEM!



By being a RAYGAMCO Member you receive substantial discounts on every item you purchase, including all hardware, software, accessories, even books and paper! You will also receive a monthly newsletter with all the latest available for your particular computer system, and much, much more — exclusive to RAYGAMCO Members only!

All the famous brand names, including:

- | | | | |
|----------------|-------------|-----------|-------------------|
| APPLE | Alpha Micro | Soroc | Lear Siegler |
| ATARI | Alpha Pro | Hazeltine | Shugart |
| EXIDY/Sorcerer | Cromemco | Sektor | Texas Instruments |
| Kim/Commodore | Xerox | PET | |

Here's how to join.

Fill out the information, and mail. That's all there is to it. Nothing to buy. I want to be a RAYGAMCO Computer Discount Club Member. Please send my RAYGAMCO Membership card to:

Name _____

Address _____

City _____ State _____ Zip _____

Computer (Brand Name) _____

I would like information on (please specify system, part, accessory, book, program, etc.) _____

WE HONOR VISA, MASTERCHARGE, BANKAMERICARD.

TOLL FREE, EXCEPT CA

Store Hours: Sat 10-6, Sun 12-4, Tu-Fri 11-8

800-854-6455

RAYGAM, INC.

6791 WESTMINSTER AVENUE WESTMINSTER, CA 92683
TELEX 182274 (714) 891-2587

Something New for your PET



PET Personal Computer Guide

by C. Donahue and J. Enger

Everything you always wanted to know about PET but Commodore didn't tell you. A practical guide to PET programming techniques, graphics, operation, and how to cope with those* & \$! PET peculiarities.

#30-6. \$15.00

NEW this Winter

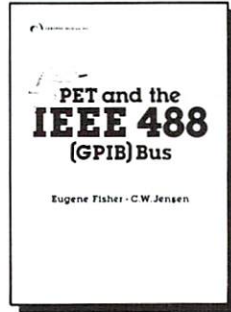

PET and the IEEE 488 (GPIB) Bus

by C. Fisher and C. W. Jensen

This is the only complete guide available on interfacing PET to GPIB. Learn how to program the PET interface to control power supplies, signal sources, signal analyzers and other instruments. It's full of practical information, as one of its authors assisted in the original design of the PET GPIB interface.

#31-4. \$15.00

NEW this Winter

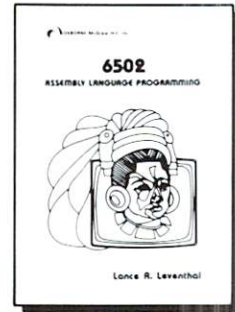

6502 Assembly Language Programming

by L. Leventhal

For the advanced programmer: increase the capabilities and performance of PET (and other 6502-based computers) by learning to program in assembly language.

#27-6. \$12.50

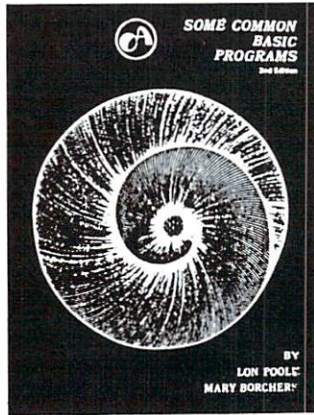

Some Common BASIC Programs

By L. Poole and M. Borchers

This book was designed for people who can use a variety of practical BASIC programs — 76 programs in all that cover a wide variety of personal finance, math, statistics, and general interest topics. The documentation in the book is complete so that you can run the programs even if you aren't an experienced programmer.

#06-3. \$12.50

PET owners can purchase the programs ready-to-run on cassette or disk, using the book as a manual for program descriptions, operating instructions and programming options.

Disk #33-0. \$22.50

Cassette #25-X. \$15.00



Book/Cassette/Disk	Price	Quantity	Amount
27-6 6502 Assembly Language Programming	\$12.50		
30-6 PET Personal Computer Guide	\$15.00		
31-4 PET and the IEEE 488 (GPIB) Bus	\$15.00		
06-3 Some Common BASIC Programs (book)	\$12.50		
25-X Some Common BASIC Programs PET Cassette	\$15.00		
33-0 Some Common BASIC Programs PET Disk	\$22.50		
California resident tax			
S.F. BART residents add 6 1/2% sales tax.			
Shipping			
Total Amount Enclosed			

Shipping: (Shipping for large orders to be arranged)

- All foreign orders \$4.00 per book for airmail
- \$0.45 per book 4th class in the U. S. (allow 3-4 weeks)
- \$0.75 per book UPS in the U. S. (allow 10 days)
- \$1.50 per book special rush shipment by air in the U. S.

Cassettes and Disk.

- No additional charge in the U.S.
- \$1.50 each foreign airmail



Name: _____
 Address: _____
 City: _____
 State: _____ ZIP: _____
 Phone: _____

OSBORNE/McGraw-Hill
 630 Bancroft Way, Dept. G
 Berkeley, California 94710
 (415) 548-2805 • TWX 910-366-7277



Review:

PET AND THE IEEE 488 Bus (GPIB),

by Eugene Fisher and C. W. Jensen.
Osborne/McGraw Hill, 233 pp. \$15.00

Review by
Jim Butterfield

The IEEE-488 bus may be a small part of the overall PET/CBM system, but there's enough in it to fill a book - and then some. One gets the impression that Fisher and Jensen could have gone on for another 200 pages or so without exhausting the subject.

It's a very thorough book, and it documents the IEEE-488 bus and PET's role in considerable detail: line by line, command by command. The book is primarily aimed at hardware enthusiasts and engineering types; but even the casual user who just plugs in and hopes it works will find useful information here. There are general descriptions of what goes on, with liberal sketches depicting the interaction in a somewhat whimsical form. There are extensive lists of compatible equipment and descriptions of applications. There's even a short diagnostic test which may help pinpoint trouble on the bus.

For those who need to plunge into technical detail, it's all there: from connector pin designations to signal sequences, everything is spelled out in detail. Chapter 5, "Execution and Timing Sequences", is the longest chapter in the book. It contains step-by-step outlines of everything that happens on the bus for every relevant PET Basic command.

There are a few things the authors didn't tackle. Chapter 6 deals with interfacing non-standard devices. The interface described is for a receive-only device which responds to everything the PET sends. A schematic is given, and a subsequent chapter details a similar interface to the Centronics P1 printer. But the design of a selecting interface, which can be called in as needed by the PET, is not touched upon. Even a brief outline here would have been useful.

Similarly, the authors stay away from the question of multiple PETs communicating with each other or with a common device over the GPIB bus. It's a tricky subject and laced with pitfalls; users would have been grateful for any hints they might have been given.

Even so, the book has a wealth of detail on all levels. There's hardly a page without a diagram, chart, illustration or photograph. Timing questions and logic sequences are described meticulously.

The book is remarkably free from errors. A few creep in: table 5-12 seems to have omitted the "unlisten" signal; page 72 should show an EOI on the last E of GENE; page 109 seems to show the CR and EOI coming from the PET rather than the external device. The sequence given on page 83: OPEN 5,5 "TEST" doesn't seem to work on my

PET: it gives a syntax error. The authors might have mentioned the one-character delay that PET introduces in the output (so that it can append the EOI signal at the right time).

I would have liked to see more attention given to multiple devices. At first glance, it appears that since PET only works one device at a time, the single-talker, single-listener description is adequate. But all devices are on-line during the selection sequences; and it seems to be important to emphasize that any device can pull a line to true and all devices must release the line to false. That's the whole point behind the three-wire handshake; yet I couldn't find the information in the introductory section.

But what the book is missing is minor compared to what it's got. It's a gold mine of both conceptual information and hard facts. It covers hardware, software, mechanical assemblies, and standards. It lists numerous devices and gives copious references.

In short, it's virtually everything you wanted to know about the IEEE-488 bus .. or are likely to want to know in the future. ©

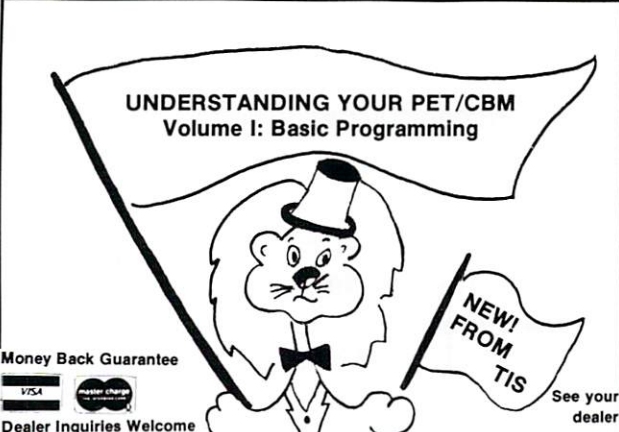

UNDERSTANDING YOUR PET/CBM
Volume I: Basic Programming

Money Back Guarantee

1974

Dealer Inquiries Welcome

See your dealer

New 248-page book includes all the former TIS workbooks except "PET Graphics." Provides information for both ROMs and a comprehensive index. Only \$14.95.

Also from TIS

WB-3 PET Graphics	\$4.95
-------------------	--------

Software products on cassette or floppy disk with complete instruction manual. Each \$24.95 (cassette), \$29.95 (diskette).

- SW-1 MAIL B mailing list system
- SW-2 CHECKBOOK record
- SW-3 ACCOUNTS keep track of who owes you how much
- SW-4 MEDIT create and maintain date files
- SW-5 CALENDAR appointments, meetings at-a-glance

TIS

P.O. Box 921, Dept. C
Los Alamos, NM 87544

Add \$2 (\$5 foreign orders)
shipping and handling

PET and CBM are trademarks of Commodore Business Machines

INTRODUCING B.E.C. FOR THE C.B.M.

Micro Mini Computer World Inc. is an exclusive distributor for the BUSINESS SOFTWARE developed by Business Enhancement Compuservice of Escondido, California.

If you are selling or using the COMMODORE BUSINESS MACHINES (CBM) computer systems, then you should provide yourself or your customers with the BEST and MOST COST EFFECTIVE software for the CBM business computer system.

CURRENT B.E.C. SOFTWARE:

- General Ledger--Master File 500 accounts
Journal File 3000 entries
- Accounts Receivable--Master File 800 customers
Invoice File 800 invoices
- Accounts Payable--Master File 800 customers
Invoice File 800 invoices
- Payroll--300 Employees
- Job Cost--800 Items
- Inventory--800 Items per disk
- Mail List/Customer Info--600 customers

B.E.C. SOFTWARE FEATURES:

- Complete and Total documentation (over 150 pages)
- Step by Step walk through on every program operation, with examples.
- Each package is Menu driven and uses dynamic load and overlay once Master Menu is booted.
- Examples are provided for all Reports and other Printed Forms.

- All Input/Output operations in regard to file accesses use the CBM random access method.
- Sorts are machine language.
- All packages are interactive with each other.

B.E.C. VALUE ADDED BENEFITS

- Total concentration to the development of software for the CBM computer systems.
- Programs can be easily modified by dealers and/or end users.
- At reasonable rates, B.E.C. will modify their software to meet customer requirements. (Complete specifications must be submitted in writing)

DEALERS and INTERESTED PARTIES may obtain a copy of the B.E.C. software documentation for \$25. If after review you are not interested send the documentation back for a full refund or you can apply the \$25 toward the first software purchase. Suggested retail for each software package is \$120. When purchasing all seven packages, the suggested retail is \$795.

DEALERS send us your letter head and proof of a legitimate computer business operation and we will forward wholesale prices that will give you DECENT PROFITS.



74 ROBINWOOD AVE. COLUMBUS, OHIO 43213
(614) 235-5813 (614) 235-6058

TREAT YOUR PET/CBM TO A

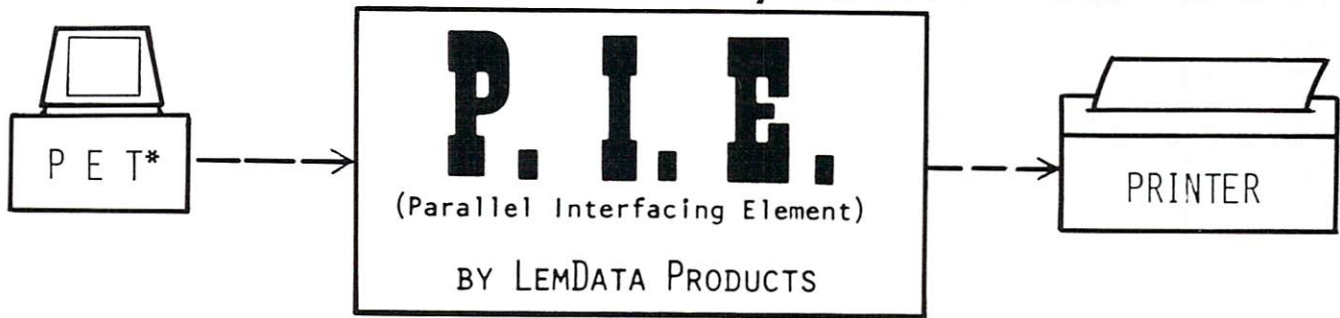

Now your 80 column CBM (or any PET/CBM) can drive your choice of high quality printers for word processing. The NEC Spinwriter and Anderson-Jacobson AJ841 can be driven as well as any other ASCII Parallel-input printer such as Centronics, Integral Data and Anadex. It's a major step in making your PET/CBM the most useful office or home appliance you have.

A printer is required for any business system and is the most desirable peripheral for any hobbyist. You know what printer you want and can think of a thousand things to do with it--

automatically type invoices and end-of-the-month statements, print all of your mailing labels or even the envelopes, make advertisements or write letters, make hard copies of those important programs for permanent back-up, print your favorite recipe for a friend, print personal telephone listings or Christmas card lists-- but you haven't found an easy way to connect it to your PET. Well, your search is over! You've found THE way to connect your printer to your PET. Treat your PET to a PIE!

The P.I.E. is an interface to connect any parallel-input printer to your PET using the IEEE-488 bus. You connect the P.I.E. to the PET and the printer to the P.I.E. It's as easy as PIE! The P.I.E. has selectable addressing and provides extension of the IEEE-488 bus to be compatible with all the other peripherals you have or may acquire.

Because the P.I.E. transfers information 8 bits at a time, it's faster than serial interfaces. And because many printers only provide serial interfaces optionally, you can save money using the P.I.E. Serial interfaces require +12v and -12v from a power supply while the P.I.E. uses only +5v which can be supplied by most printers themselves. No tangle of wires to contend with and you save again. If your printer can't supply power, the P.I.E. can also be connected to a power supply using the power cable provided on the P.I.E.

The P.I.E. uses the IEEE-488 bus of your PET

and the 488 Basic commands such as PRINT#, CMD, etc. You don't need to load software routines, which also slows the printing down, because the 488 commands are always available in Basic.

Because the PET in lower case mode outputs the wrong ASCII codes, the P.I.E. provides for the use of an optional, switch selectable, Code Converter ROM to output the correct ASCII codes to match all the ASCII characters displayed on the PET screen.

The P.I.E. provides 8 latched TTL data bits and 2 TTL handshaking lines (both positive and negative handshaking supported) so any parallel-input device can be driven. This could include devices other than printers, such as plotters or even AC relay control devices.

Documentation includes instructions for using OPEN, PRINT#, CMD and CLOSE commands, how to set the device# of the P.I.E. and the set-up and test procedures.

The P.I.E. is fully assembled and ready to use. Cables are optionally available for most printers (with both connectors or connector for P.I.E. only). For FULL-CABLE please specify printer model, type of connector and pin/signal designation.

SO STOP SEARCHING AND START ENJOYING.

P.I.E. -----\$89.95
FULL-CABLE-----\$39.95

PLACE YOUR ORDER FOR A P.I.E. TODAY!!
CODE CONVERTER -----\$14.95
SEMI-CABLE-----\$19.95

Prices include shipping and handling for checks and money orders. COD add \$5. Md. res. add 5% tax. Allow 4 to 6 weeks delivery.

**LemData Products, P.O. Box 1080,
Columbia, MD. 21044 Phone (301) 730-3257**
***PET is a trademark of Commodore
Business Machines**

Review:

6502 Software Design,

Review by
Jim Butterfield

by **Leo J. Scanlon**
Howard W. Sams & Co., Inc.,
270 pp. \$10.50

This is quite a pleasant book; it makes good reading. The title is misleading: the book deals with 6502 programming rather than software design. In fact, I rather missed the software design elements: planning memory, designing data structures, and testing/debugging methodology are important concepts for beginning programmers. The book expends its main efforts on the subjects of writing code and handling interrupts and input/output devices.

The book is oriented towards the Rockwell AIM 65 microcomputer, but not too heavily. Users of other systems will find it a worthwhile reference of text. The book appears ideal for a programming course textbook; it is well organized and gets into serious programming quite quickly.

Chapter 1 is partly historical, partly an overview of popular microprocessors and partly a brief plug for the AIM 65. There's a minor problem where the author describes the 6800/6502 family as characterized by novel memory-mapped architecture: in fact, all microprocessors including the 8080 and Z-80 can and do use memory mapped I/O. And I rather wish that the introduction to the 6502 had mentioned its remarkable speed due to pipelining techniques - a factor that sets it clearly ahead of the earlier 6800.

Chapter 2 gets into the 6502 instruction set. Similar op codes are grouped and discussed together, which helps to develop intuitive ideas of the machine's capabilities. Numerous examples of coding are included. The style is generally easy and straightforward, but beginners will still find it slow going: there's a lot of material to get through.

Subroutines are covered in chapter 4, mostly in terms of their mechanistic characteristics. A couple of time delay subroutines are given, and it's nice to see timing questions being worked through meticulously.

Chapters 4, 5 and 6 get heavily into coding questions: list and lookups, mathematical routines, and number-base conversion. Coding is given throughout, but the emphasis is on algorithms: the author is concerned with the methods behind a particular kind of computation. A rather unusual algorithm is given for calculating the square root of an integer; it's rather slow compared to standard methods, but readers may find it an interesting curiosity.

Chapter 7 discusses interrupts. In sixteen pages, it's hard to come to grips with the whole question,

and coding examples are cursory. Chapter 8 goes into considerable detail on two input/output chips: the 6520 and 6522.

There are two appendices and an index. I found the index rather sparse: for example, "relative addressing" points you to page 40, but a more useful discussion can be found on page 55.

Coding examples are written almost entirely in assembly language. This is quite readable, but I would have preferred to see early coding examples complete with their machine language equivalents.

The overall organization of the book is good, although there are inconsistencies within chapters: some have summaries, some have references, and some have neither. Chapter 2 has a section entitled "How this chapter is arranged"; it appears on the sixth page of the chapter, which seems odd.

The coding is good, but there are a few errors. On page 68, the author suggests that when shifting signed numbers to the left, the programmer should arrange to restore the sign bit in case it's shifted out; in fact, a change in the sign bit would be an overflow situation and there would be no repairing the damaged number. Example 5-14 on page 139 should add a value of two to location 22 rather than the value of one shown; most alert readers will pick this kind of thing up. Hardware purists may wince at some of the terminology, such as use of the term "grounded" instead of "logic zero" or "low", but everybody will understand what is meant.

The author has a conversational style and avoids jargon. Occasionally, there's a lapse: I'm sure that there's an easier explanation of immediate addressing than "the operand resides in the second byte of the instruction".

The author covers a lot of material in 231 pages of text. It's not light reading, but it is well presented. 6502 programmers and beginners will find it useful. ©

Grand Opening... Systems Formulate Corporation.

Your microcomputer information center.



We welcome you to visit our first consumer/commercial sales center in the United States. Located in Palo Alto in the Town and Country Village Shopping Center, Systems Formulate features a full range of microcomputer systems and peripherals for home or commercial use.

During the past few years since our founding in 1978, we have opened three retail stores in Japan stocking premiere American-made microsystems and innovative Japanese systems.

Our new Palo Alto location will feature some exciting surprises for the American interested in microprocessing.

Miplot, The Intelligent Plotter. . .Only \$1,200

Usable even by those with no plotter experience, the Miplot is an ideal graphic output device for the personal and small business computer. It's light, compact, and uses ordinary, hard-tip felt pens. (Interface and cable available)

Special features Include:

- * Separate pulse motor drives for x and y axis
- * Full range of intelligent functions such as line generator and character generator
- * Self-test mode to verify plotter results
- * Printer mode for easy interface testing and data dumping

For research, development and management planning, or use by the personal hobbyist. . . Miplot is the intelligent plotter worth your attention.

Now on display at Systems Formulate.

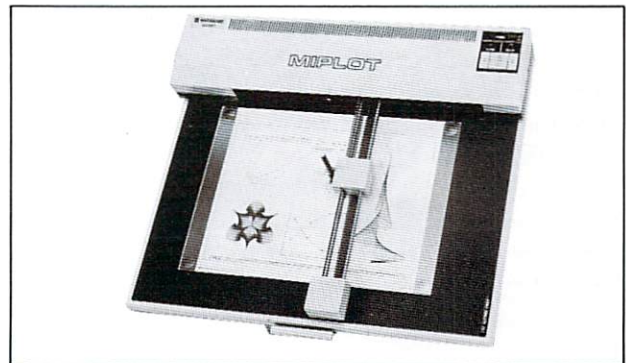

Rugged, continuous-feed printers . . .Only \$1,995.

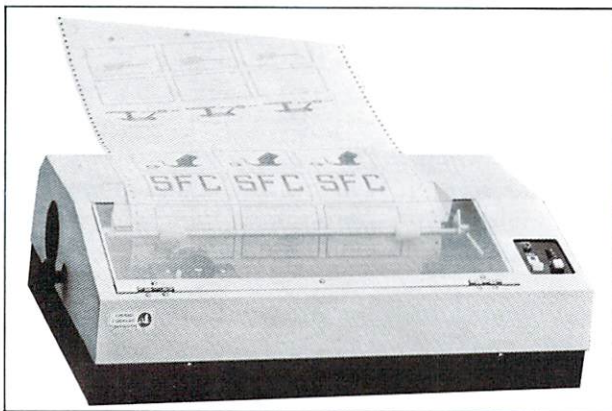

Systems Formulate presents two, new continuous feed printers designed to withstand all the heavy duty use your invoices, statements and statistical analyses can dish out.

Both the SFC-080 and the SFC-136 combine Japanese craftsmanship with many of America's finest components. Like the UMI 8 dot high matrix head, for example.

But that's just the beginning:

- * Superior data editing ability
- * Your choice of paper size
- * Sharp, clear printouts
- * Bold double-size characters
- * Graphics
- * Versatile line spacing
- * Paper-saver tractor feed
- * Innovative space saving design

Call Systems Formulate and we'll be happy to send you detailed specs or, better yet, drop by for a personal demonstration.

SYSTEMS FORMULATE CORPORATION



39 Town & Country Village
Palo Alto, California 94301
(415) 326-9100

Store Hours: Monday-Saturday, 10-7
Sunday, 12-6

BIG FILES ON A SMALL COMPUTER

Elizabeth Deal
337 W. First Ave.
Malvern, Pa. 19355

The program described here demonstrates a way of reducing data storage requirements by a factor of eight. It is written in Microsoft Basic for a PET computer.

I have seen several programs that create and use cross-index files for library search, statistical surveys and similar applications. They usually require large computers, such as a 48K system with two disk drives. A very thorough file handling system has been described recently by Dr. Sanger in the November, 1979, issue of **Microcomputing**. In his article each attribute is coded as two letters and six attributes are permitted for each record. This requires twelve letters and, therefore, twelve bytes.

In the method described here, each attribute is coded as yes or no and the user can have as many attributes as he desires. If the application lends itself to such coding into a list of keys or attributes, then this system will permit the handling of large amounts of data in core at one time. It also permits the use of logical AND, OR or NOT operators in retrieval with any combination of attributes.

By way of illustration, a library search requires quick access to those entries that contain desired subject matter. Two, three, or six byte coding of each key is very core consuming, and limits the number of records that can be in core at one time.

The solution I propose is twofold: (1) set up a smart coding procedure for classification of subjects described in an article into keys that can be scored yes or no, and (2) "pack" the data for storing it in core, on tape or on disk, and then "unpack" it, one record at a time, during the search for the applicable attributes. This paper describes an efficient way to "pack" and "unpack" the data so that a larger file can be searched on a small computer without the use of accessory memory devices, such as disks. Of course, if one has a system with a disk the method described here would permit use of an even larger file. We are aware that the first part of the solution (setting up the coding procedure) is challenging. It is the real problem and the performance of the system depends on how logical and meaningful the selected keys are.

Each logical record consists of the text part and the data part. The text part must be adequate for positive identification of the articles being searched, but the length should be kept to a minimum. Name, date, and page might be enough. The data part is what we can compress. The yes-no or 1-0 codes are entered in groups of fifteen ones and zeros.

These, in turn, are packed into the two byte integer variable S%.

Fifteen attributes require two bytes, thirty attributes require four bytes, and so on. A user of the system need not concern himself with what the program does with binary numbers. He only needs to know that there will be as many S% values per record as there are groups of fifteen keys. The user then needs to provide a decision for retrieving the records of interest to him. The decision is written as a statement at the beginning of a program and is immediately edited for syntax-type errors. Logical operators AND, OR, NOT, as well as arithmetic ones (=, <>, <, >) are used. The decision can be written on one or more lines leading to a combining variable TR. TR is set to one if true, and all records meeting TR condition are then displayed. Complete instructions for writing TR lines are listed in lines 2970 to 3420.

How is it done? For once those long tables of powers of two, that are a part of every book on programming, come in handy. The program is set up in such a way that the user thinks of the list of fifteen keys from left to right, 1 to 15. The program sees them as being numbered from right to left, 0 to 14. Like this:

```
-Key numbers B%(k)k = 1 2 3 4 5 6 7 8 9 10 11 12
13 14 15
-Program sees as m = 14 13 12 11 10 9 8 7 6 5 4 3
2 1 0
-Input key values 1 0 0 0 1 1 1 1 1 1 0 0 0 0 0
```

The program now takes key values and wherever it finds a "1" it raises 2 to the m-th power. The sum of all this is then stored in integer variable S%(record number, sum number)*. The bytes are used instead of at least 15. During the process of retrieval the opposite procedure takes place - the sum is "unpacked" into working storage of 15 values. The same values are, of course, reused by all records. The lines of the program that drive this system are 1470 to 1510 and 1920 to 1990 the other way. It seems like a lot of hassle, but the core saving is tremendous. The loops that do the packing and unpacking take from 0.2 second to 0.9 second, the latter representing all fifteen bits on. (These times could be reduced by rewriting these two loops as machine code subroutines.) Another way to save time would be to set up the most frequently used keys next to one another as this will leave the loop sooner. In the example shown above, the program will loop ten times. Had a "1" been in position 4 or 11 the loop would be executed five times.

The program now has two sections. One packs the data, the other unpacks it. In between, the values should be stored on tape. And at the beginning, routines for creating and updating files should be provided. As listed, the program works as if it were a file system. It can be used as a training ground in writing decision lines. It should be used as a part of a larger system.

Buy Direct From CompuMart

COMPUMART NOW OFFERS THE ENTIRE DEC LSI-11 PRODUCT LINE - CALL FOR PRICES & DELIVERY.



Buy Direct from the Largest Commodore Dealer in the Country — NCE/CompuMart.

- 8K-Keyboard N \$795
- 16K-Keyboard B \$995
- 16K-Keyboard N \$995
- 32K-Keyboard B \$1,295
- 32K-Keyboard N \$1,295
- B — large keyboard (graphics not on keys)
- N — large keyboard with graphics symbols

SUPER SAVER. Thanks to Commodore their printer prices have been drastically reduced:

- Commodore Printer (tractor feed) was \$995 **NOW \$795**
- Commodore Printer (friction feed) was \$849 **NOW \$695**

2 Good reasons for buying your PET™ from CompuMart:

(1) \$100 IN FREE ACCESSORIES WITH 16K or 32K PET.
When you buy a 16K or 32K PET, apply \$100 toward PET accessories. FREE. Choose from the accessories listed below and indicate on your order that you have reduced the cost of your accessories by \$100.

(2) FREE WITH PURCHASE OF ANY PET (Offer extended until May 15, 1980)

A Texas Instruments' Hex/Octal Calculator (\$60 Value), and a set of 6 PET Workbooks (Worth \$36).

PET Accessories

- Commodore Dual Floppy Disk Drive \$1,295.00
- Second Cassette—from Commodore \$95.00
- Commodore PET Service Kit \$30.00
- Beeper—Tells when tape is loaded \$24.95
- Petunia—Play music from PET \$29.95
- Video Buffer—Attach another CRT \$29.95
- Combo—Petunia and Video Buffer \$49.95
- TNW Bi-Dir RS-232 printer S-face \$229.00
- KIM 1 (A Single Board Computer from Commodore) \$179.00
- PET to IEEE Cable \$39.95
- IEEE to IEEE Cable \$49.95
- KIM1 & Power Supply Package Special \$200.00



We have a complete inventory of Apple computers, peripherals, & software In-Stock for immediate delivery —

\$200 in FREE accessories with the purchase of a 48K Apple II reg. or Apple II plus.

- 16K Apple reg. or plus — \$1,195 (\$100 in free acces.)
- 32K Apple reg. or plus — \$1,395 (\$150 in free acces.)
- 48K Apple reg. or plus — \$1,495 (\$200 in free acces.)

Apple Accessories

- PASCAL \$495
- Micromodem \$379
- VisiCalc \$150
- The Controller (Business Package) SALE! \$550
- The Cashier (POS System) SALE! \$200
- Integer BASIC ROM Card \$200
- Centronics Printer Interface \$225
- Disk and Controller \$595
- Parallel Printer Card \$180
- Communications Card \$225
- Hi-Speed Serial Card \$195
- Firmware Card \$200
- NEW! AppleWriter Text Editor \$75

NOVATION CAT™ ACCOUSTIC MODEM

- Answer Originate • Bell 108
- 300 Baud • Low Profile Design

Looks good, works great! **\$179.00**



NEW FROM EXIDY

THE SORCERER II 48K COMPUTER

Z-80 Microprocessor, Full-sized keyboard • ROM PAC Programs • Microsoft BASIC • Powerful Graphics • Serial and Parallel I/O • Dual Cassette I/O Memory Internally Expandable • S-100 Expansion Options.
48K Sorcerer II \$1,395

Commodore's 3 for 2 is Back! SPECIAL OFFER TO EDUCATORS - GET A FREE PET COMPUTER

For a limited time only, when your school buys any 2 PET's at the regular list (see our PET™ prices listed above), Commodore will include another PET in the deal, absolutely FREE! Call CompuMart TOLL-FREE for complete details.

CENTRONICS PRINTERS



The 779-2 is a tractor feed printer designed for small business systems. Uses a 5x7 dot matrix to produce all 64 upper case ASCII characters. Centronics is the biggest name in printers and this is their most popular model.
List. \$1,245 **SALE! \$1,079**

The New 730-1 parallel matrix printer is ideally suited for all personal and microcomputer systems. Standard Features include: 100 cps • 80 char./line • 3-way paper handling system • 7x7 dot matrix • 96 character ASCII • List \$995 **SALE! \$839**

To meet our Centronics' quotas we are offering these great specials on their printers!
753-9 9 x 9 Data Processing Printer. List: \$2,995 **SALE! \$2,395**

- 704-9 9 x 9 180 CPS. List: \$1,995 **SALE! \$1,750**
- 701-9 9 x 9 Matrix. List: \$1,595 **SALE! \$1,395**
- 730-3 Serial 730. List: \$895 **SALE! \$745**

Brand New. Centronics Model 737, the first printer in its class capable of offering print quality suitable for text processing, plus the performance & application flexibility required for data processing. Unbelievable quality of type.

- 737-3 Serial Word Processor Printer \$1,045
- 737-1 Parallel Word Processor Printer \$995

The Perfect Printer for Small Business Systems

The Paper Tiger Printer From Integral Data

ROAR!

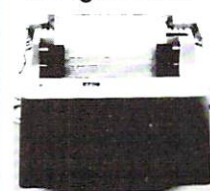

Standard features include: 4 character 8.3 to 16.5 cpi • 56 cps at 10 char. per in. • Selectable line spacing • 8 switch-selectable form sizes.

The IDS Graphics Option for the Paper Tiger allows full dot pattern control and includes an expanded 2048-byte buffer (a 256-byte buffer is standard).

- IDS Paper Tiger Printer \$995
- IDS Graphics Paper Tiger Printer \$1,094

SANYO MONITORS

- 9-inch reg. \$199 **SALE! \$169**
- 15-inch reg. \$299 **SALE! \$269**

Perfect for Apple users ... Sanyo Cassette Recorder \$55



ZENITH

EXCLUSIVE FROM COMPUMART!

COLOR VIDEO MONITOR

Beautiful Display Capabilities. Excellent for use with Apple, Atari, & Sorcerer Computers. This 13-inch monitor is Zenith's first color video display designed specifically for computers. Features include color and degaussing circuits.
Zenith Color Monitor \$499.00

HAZELTINE TERMINALS AT SPECTACULAR SAVINGS!

Hazeltine 1410-TTY-style keyboard, 8 baud rates from 110 to 9600, 12" screen, 24x80 display, 5x7 dot Matrix Upper Case ASCII character set, 12-key numeric keypad. List Price \$895 **SALE! \$779**
Hazeltine 1500 — 8 baud rates from 110 to 19,200, and ANSI Standard Keyboard, EIA RS-232, All 94 Upper/Lower Case characters in a high resolution 7x10 matrix display. Much more.
List Price \$1,145 **SALE! \$995**
Hazeltine 1520 — Take advantage of this \$310 savings while it lasts! The Hazeltine 1520 is a powerful multi-processor terminal.
List Price \$1,585 **SALE! \$1,275**



THE SINGLE BOARD DEVELOPMENT SYSTEM ROCKWELL AIM 65

6502 Microprocessor • 20-character, alpha-numeric LED display • Full-size 54-key keyboard with 3 user-defined functions • Fast, on-board 20-column thermal printer • 8K Advanced Interactive Monitor program • Dual cassette interface board • On-board timer • On-board ROM expansion to 12K • 4K on-board RAM • On-board TTY interface • 16 parallel I/O lines • One serial I/O port • KIM-compatible edge connectors for even further memory or I/O expansion.

The CompuMart AIM System combines all of our options for the AIM to give you the capabilities of development systems costing 5 to 10 times as much. This system includes a 4K AIM 65 with BASIC and Assembler, an MTU power supply, a Sanyo tape recorder and an EGI Enclosure for the AIM.

- CompuMart AIM System \$785.00
- 4K AIM-65 \$450.00
- Paper for the AIM \$4.75

CompuMart

We've Had a Reputation for Dependability Since 1971.

Dept. K, 270 THIRD ST., CAMBRIDGE, MA. 02142

To Order: 1 (800) 343-5504

In Mass: 1 (617) 491-2700

Member Computer Dealers Assoc.



To customize the program for your system (1) delete lines 2770 on to reduce core from 10K to 5.2K, (2) in line 1020 insert the maximum number of records that will fit, (3) modify G if you wish in lines 1020 and 1340 (G = 1 or 2 is now permitted), and (4) insert your machine size in line 2450.

As written, the program takes about 5.2K after removal of all REM lines that are at the end. A search type program that would contain a dictionary of keys should take no more than 6K. How many records can various systems handle? If we assume that each record has 26 bytes of text plus 30 yes-no attributes, an 8K system could search 66 records, a 16K system could search 330 records, and a 32K system could search 866 records. A 100K disk would add 3,333 records and a half-megabyte disk would add 16,500 records.

$$* S\%(nr,g) = 2^5 + 2^6 + 2^7 + 2^8 + 2^{10} + 2^{14} = 18,400$$

Credits: Ken Brossoie

Microcomputing, November, 1979, page 44.

Neil Harris, A-B Computers, Montgomeryville, Pa.

```

1000 C0=0:C1=1:C2=2:C3=3:C5=5:C6=6:
      -CA=10:CE=14:CF=15:D$=""
1010 REM ELIZABETH DEAL,MALVERN,PA
1020 R= 200:G=2:DIM HD$(R),S%(R,G),
      -WA$(15),V$(G),B%(15*G),QQ%(15)
1030 FORJ=C1TOCF:READWA$(J):NEXTJ
1040 FORK=0TOCE:QQ%(K)=C2^K:NEXT
1050 :
1060 :
1070 REM RENUMBER 1000,10 WHEN NEEDED
1080 :
1090 REM>>>> R E A D   T H I S   <<<<
1100 REM           INSERT DECISION
1110 REM   KEEP LST-TR-RTRN SEQUENCE
1120 :
1130 LIST-1280
1140 DX=ABS(B%(1)ORB%(2)):
1141 DY=ABS(B%(3)ORB%(4)):
1142 DZ=ABS(NOT(B%(5)ANDB%(6))):
1143 TR=ABS(DXANDDYANDDZ):
1150 RETURN
1160 :
1170 REM>>>>> ':' MUST END EACH LINE
1180 :
1210 REM TR=ABS((B%(1)ANDNOTB%(2)) //
1220 REM TR=ABS(S%(N,2)>512)WILL DIS-
1230 REM PLAY RECS MEETING STMT TR.
1240 :
1250 REM >> TYPE 'RUN', VERIFY, THEN
1255 REM   TYPE 'GOTO1300' TO CONT.
1260 REM   (OR ~ ~ THIS LINE#)
1270 :
1280 REM ===== SECTION 1 =====
1290 :
1300 A=TI:REM //CHOSE SEC.1/2 HERE ///
1310 GOSUB2420:REM // SUBR 1 ///
1320 PRINT"n":N=1:LT=0
1330 PRINT"HOW MANY GROUPS OF 15 KEYS -
      -?":PRINTTAB(9)"ENTER 1 OR 2"
1340 INPUTG:PRINT:IFG<1ORG>2GOTO1330
1350 PRINT:PRINT:PRINT"ENTER TEXT,
      - OR 'XX' TO END INPUT"
1360 PRINTTAB(2)"!";TAB(27)"!"

```

```

1370 INPUTHD$(N):IFLEFT$(HD$(N),
      -2)="XX"THEN1550
1380 HL=LEN(HD$(N)):E=0
1390 REM // INPUT15 BITS,FLAG ERRORS
1400 :FORJ=C1TOG:PRINT:PRINT"15 KEYS";
1410 PRINT"!!!!!!!!!!!!!!!!!" :PRINTTAB(
      -7);:INPUTV$(J)
1420 :FORLL=C1TOCF:S$=MID$(V$(J),LL,1)
1430 IF(S$<>"0"ANDS$<>"1")THENE=E+1:
      -GOTO1450
1440 :NEXT
1450 :NEXTJ
1460 IFE>0THENPRINT:PRINT"rERROR DO -
      -AGAIN":GOTO1350
1470 TX=TI :FORJ=C1TOG:S%(N,J)=C0
1480 :FORL=C0TOCE:PQ=VAL(MID$(V$(J),
      -CF-L,C1)):IFPQ=0THEN1500
1490 S%(N,J)=S%(N,J)+QQ%(L)
1500 :NEXTL:PRINTTAB(14)"SUM="S%(N,J)
1510 :NEXTJ:TY=TI
1520 PRINT(" ;INT((TY-TX)/C6)/CA;"SEC");
      -:PRINTTAB(25)"OK";N;"OF";R
1530 N=N+C1:LT=LT+HL:IFN<=RGOTO1350
1540 PRINT:PRINT:PRINTTAB(6):PRINT"*****
      -** NO MORE ROOM *****"
1550 PRINT:PRINT:PRINT:PRINT"# OF -
      -RECORDS PUT IN";N-1:PRINT
1560 PRINT"# OF BYTES USED BY TEXT";LT
1570 PRINT"# OF BYTES USED BY KEYS";
      -2*G*(N-C1):PRINT:PRINT"BYTES -
      -LEFT";FRE(0)
1580 PRINT:PRINT:PRINT
1590 PRINT"HIT 'S' TO STOP":PRINT"ANY -
      -KEY TO CONTINUE"
1600 GETA$:IFA$=""THEN1600
1610 IF A$="S"THENSTOP:REM/CHANGE/
1620 :
1630 REM // STORE DATA ON TAPE HERE
1640 :
1650 REM ===== SECTION 2 =====
1660 REM
1670 REM >> # OF RECORDS (NR), TEXT
1680 REM REC (HD$(NR)) AND G-SUMS
1690 REM S%(R,G) ARE USED IN THIS
1700 REM SECTION; BITS ARE COMPUTED
1710 REM AND ASSIGNED TO KEYS ARRAY
1720 REM           B%(G*15)
1730 REM >> B% OR S% ARE CHECKED FOR
1740 REM COMPLIANCE WITH TR STMT.
1830 REM
1840 REM =====
1850 REM
1860 PRINT"n":NR=N-1
1880 :FORN=C1TONR:K=C0:JA=TI
1890 IFKS>C0THEN2000
1910 FORK=C1TOG*CF:B%(K)=0:NEXT
1920 JS=TI:FORJ=C1TOG:TP=S%(N,J):
      -JJ= J-C1
1930 IFTP=C0THEN1990
1940 Q=INT(LOG(TP)/LOG(C2)):U=CF-Q
1950 :FORM=C0TOQ:BP=QQ%(Q-M)
1960 IF(TP)>=BPTHENB%(CF*JJ+U+M)=C1:
      -TP=TP-BP
1970 IFTP=C0THEN1990
1980 :NEXTM
1990 :NEXTJ:JE=TI
2000 FORM=1TO4:PRINT"===== ";:NEXT

```

```

2005 PRINT:PRINTHD$(N)
2010 GOSUB1140:IFTR<>1THENPRINT:
    -PRINT"*** NO MATCH ***":GOTO2030
2020 PRINT:PRINT"THIS RECORD MATCHES:"
2030 PRINT:PRINTTR$
2040 :FORJ=C1TOG:
2050 PRINT"GROUP";J;"SUM=";S%(N,J):
    -NEXTJ:PRINT
2070 IFKS>C0THEN2130
2080 K=C1:PRINT:FORJ=C1TOG
2090 PRINT"BIT";(J-C1)*(K-C1)+C1;:
    -PRINTTAB(7);" -> ";:PRINTTAB(12);
2100 :FORK=C1TOCF:PRINTRIGHT$(STR$(B%(CF
    -* (J-C1)+K)),1);
2110 :NEXTK:PRINT" <- ";J*(K-C1)
2120 :NEXTJ
2130 PRINT:PRINT:PRINT"(TIME IN BIT -
    -LOOP";INT((JE-JS)/6)/10;"SEC)"
2140 PRINT"(TOTAL TIME:";INT((TI-JA)/6)/
    -10;"SEC)"
2150 :FORM=1TOCA:PRINT"====";:NEXT
2160 PRINT:PRINTTAB(11)"HIT ANY KEY FOR -
    -MORE"
2170 PRINTTAB(6)"'Q' TO QUIT AND RERUN -
    -OPTIONS"
2180 GET A$:IFA$=""GOTO2180
2190 IFA$="Q"GOTO2210
2200 :NEXTN:REM // END REC LOOP /
2210 PRINT"â†•â†•"TAB(16)"OPTIONS":PRINT
2220 PRINT"1. SAME TR, NEW DATA -
    -STARTING AT REC";NR+C1
2230 PRINT"2. RERUN: SAME TR AND DATA"
2240 PRINT"3. Q U I T"
2250 GETD$:IFD$<"1"ORD$>"3"GOTO2250
2260 ONVAL(D$)GOTO2270,1880,2280
2270 N=NR+C1:GOTO1350
2280 PRINT"â†•â†•SURE?"
2290 GETA$:IFA$=""N"GOTO2210
2300 IFA$="Y"THEN END:REM /PROG END/
2310 GOTO2290
2320 REM === DATA=FOR SUBR.1 =====
2330 :
2340 DATA"NOT","","+","-","*","/","","
    -"AND"
2350 DATA"OR",">","=","<","","","ABS"
2360 :
2370 REM =====
2380 :
2390 REM SUBROUTINE 1
2400 REM FIND AND EDIT TR STATEMENT
2410 :
2420 TR$="":LX=0:KB=0:KS=0:P=0:J1=1:
    -KC=0:L1=0:R1=0:SB=0:JA=0:JZ=0
2440 PRINT"â†•FOUND 'LIST' AT";
2450 :FORJ=1350TO32000-FRE(0):IFPEEK(J)=
    -155THENPRINT" ***";J:JA=J
2460 IFPEEK(J)=142THENJZ=J:PRINT"FOUND -
    -'RETURN' AT ***";JZ:GOTO2475
2470 :NEXTJ
2475 IFJA=0ORJZ=0THENPRINT"CAN'T FIND -
    -DECISIONS; SEE SUB1 LISTING ":STOP
2480 :FORJJ=JA+11TOJZ:LL=PEEK(JJ)
2490 IFLL=58THENJJ=JJ+5:LP$=CHR$(13):
    -GOTO2540
2500 IFLL<128THENLP$=CHR$(LL):GOTO2540
2510 :FORM=168TO182:IFLL=MTHENLP$=WA$(M-
    -167):LX=LX+LEN(LP$):GOTO2530
2520 :NEXTM
2530 IFM=182THENSB=SB+1
2540 LX=LX+1
2550 IFLX>255THENPRINT"STRING TOO -
    -LONG-LIMIT 255":E5=1:GOTO2700
2560 TR$=TR$+LP$
2570 :NEXTJJ
2580 :FORJJ=J1TOLX+1
2590 M$=MID$(TR$,JJ,1):KB=KB-(M$="B"):
    -KS=KS-(M$="S"):P=P-(M$="%")
2600 KC=KC-(M$=""):L1=L1-(M$=""):
    -R1=R1-(M$="")
2610 NEXTJJ
2620 PRINT" B ";" S ";" % ";" , ";" ( ";"
    -" ) ";"ABS";" L "
2630 KB=KB-SB:KS=KS-SB
2640 PRINTKB;KS;P;KC;L1;R1;SB;LX
2650 PRINT:PRINTTAB(5)"YOUR DECISION IS:
    -":PRINT:PRINTTR$:PRINT
2660 E1=(KB>0)AND(KB<>P):E2=(KS>0)AND(KS
    -<>P):E3=(KS>0)AND(KS<>KC):
    -E4=(L1<>R1)
2670 IFE1ORE2THENPRINT"* USE % -(B% OR -
    -S%) !!":PRINT" USE NO OTHER B, S,
    - %"
2680 IFE3THENPRINT"* USE S%(N,#)FOR -
    -2-DIM ARRAY"
2690 IFE4THENPRINT"* ( ) DON'T MATCH:
    -";L1;"LEFT, AND";R1;"RIGHT"
2700 IFE1ORE2ORE3ORE4ORE5THENPRINT:
    -PRINT"TYPE 'RUN' TO FIX":STOP
2710 PRINTTAB(5)"HIT ANY KEY TO -
    -CONTINUE"
2720 PRINTTAB(3)"OR 'STOP' TO CORRECT/CH
    -ANGE"
2730 PRINT:PRINTTAB(5)"THEN TYPE 'RUN' -
    - TO FIX"
2740 PRINT:PRINT"(EDITING AND RE-RUN -
    -WIPE OUT DATA)"
2750 GETA$:IFA$=""THEN2750
2760 RETURN
2770 REM =====
2780 REM EXAMPLE OF INPUT FOR ONE
2790 REM LOGICAL RECORD WITH TEXT
2800 REM AND 2 GROUPS OF 15 ATTRI-
2810 REM BUTES EACH, STORED AS
2820 REM 25+4 BYTES.
2830 REM
2840 REM >TEXT:
2850 REM ! !
2860 REM 1.MAG.NAME/11-78/ /P.106
2870 REM >FIRST 15KEYS
2880 REM 111010000001011
2890 REM >SECOND 15KEYS
2900 REM 001001000100010
2910 REM >END OF DATA
2920 REM ! !
2930 REM XXXX
2940 REM
2950 REM =====
2960 REM
2970 REM POSSIBLE USES OF TR LINE(S)
2980 REM
2990 REM 1.DECISION IS WRITTEN AT THE
3000 REM START OF A RUN AND CANNOT BE
3001 REM CHANGED DURING THE RUN.
3005 REM

```

Computer Supplies for Small Computer Systems

Commodore Printer Ribbons

IN STOCK

Our full line
of supplies includes:
Diskettes (3M, BASF)
Diskette retrieval devices
Tractor printer paper
Tractor printer labels
Computer ribbons
Dust covers
Adapters
Uncrashers
Computer desks
NEC Spinwriters
Xymec intelligent printers
New dealer kits

ZEIGLER ELECTRONIC PRODUCTS

DEALERS:

We no longer market COMMODORE
Equipment, (Jerry Zeigler is with
Commodore) but Connie and I have the
computer supplies you need to support
Commodore System Sales.

Give us a call:

Trudie Zeigler

or

Connie Rittenberry

(404) 289-1596 or 289-2265

3661 CALUMET RD.

DECATUR, GEORGIA, 33034

Using The PET's Second Cassette Buffer To Increase Available Memory Space

Chuck Stuart, President
CMS Software Systems, Inc.
5115 Menefee Drive, Dallas, TX 75227

If you have tried all the known memory saving tricks to reduce the size of your new super program to save mankind and it still won't fit into your PET's available memory, you might be able to save the day by storing part of the program in the PET's second cassette buffer.

The second cassette buffer begins at address 826 and extends through address 1023. If your program does not use the second cassette then you can use this 197 bytes for program storage. Granted, 197 bytes may not seem like a lot of extra space, but used correctly it can save you several times that much space in the PET's regular memory.

Suppose, for instance, your program requires a deck of 52 cards to be stored in memory. Such a deck would normally contain the values 1 through 52 and be stored in an integer array referenced by a name like D%. Since each element in an integer array requires two bytes of memory and there are 52 elements in our array, we can see that, stored as a normal integer array, our deck of cards would require 104 bytes of storage space plus at least another 7 bytes and probably more to properly dimension the array.

Since no array element value exceeds 255, this array could easily be stored in the second cassette buffer with each element requiring only one byte for storage. By moving our deck of cards into the second cassette buffer we have saved a minimum of 111 bytes of main memory while using only 52 bytes of the 197 available to us in the second cassette buffer. This same method works equally well for single element integer variables and strings.

If you simply use this extra space for temporary storage of information during program operation then no special problems are created. If you make full use of the second cassette buffer for permanent storage of program data such as operator prompts, suit symbols for your card deck, or other values normally stored in DATA statements, etc., then the second cassette buffer must be stored along with the main program. Since the SAVE command begins saving at location 1024, any data stored below that address in the second cassette buffer would not be saved by using the standard SAVE command.

Fortunately by using the PET's built-in ROM Monitor we can specify the exact beginning and ending addresses we want to save. If you still have the old ROM set without a Monitor don't panic. I'll show you how to save the buffer a little later.

The first thing you have to do is determine the address range you want to save in hexadecimal. As we pointed out before, the second cassette buffer begins at location 826 decimal or 033A in hex so we know that we want to start saving at location 033A hex. To determine the ending address you must first save your program onto tape using the normal SAVE command, and then load it back into memory with the LOAD command. Data stored in the second cassette buffer will not be affected by this operation. Now type PRINT PEEK(43)*256 + PEEK(42). The answer you get will be the address in decimal where your program ends and which you must now convert to hex. (If you've never taken the time to learn how to convert decimal to hex and vice versa because you figured you would never need to know then you were wrong.)

Now that you know the memory range you want to save, enter the Monitor by typing SYS1024 and pressing RETURN. To save your program including the data stored in the second cassette buffer, type the following line exactly, substituting the ending address for XXXX and filling in your own program name, and press RETURN:

S "PROGRAM NAME",01,033A,XXXX

PET will display the standard PRESS PLAY AND RECORD message and then save your program on tape in the normal manner except it will begin saving at location 826 instead of the usual location 1024 where your BASIC program begins. You can LOAD and use the program in the normal manner except that you must always use the Monitor to save the program or else you will lose any data stored in the second cassette buffer. This means that no one else will be able to copy your program unless they know the secret. There is one other thing to remember. If you make any changes to your program, don't forget to redetermine the new ending address before using the Monitor to resave the program.

If you have the old ROM set without a Monitor then you can accomplish the same result in the following manner:

- A) Save the program with the SAVE command and then reload it with the LOAD command.
- B) Type POKE247,58:POKE248,3 and press RETURN.
- C) Type SYS63153 and press RETURN.

PET will display the standard PRESS PLAY AND RECORD message and save the program beginning



Skyles Electric Works

PAL-80™

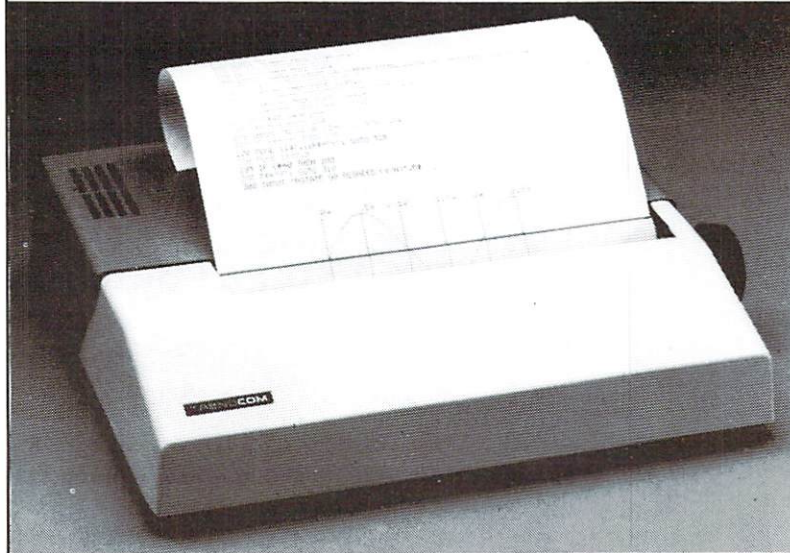

- 80 characters per line
- 8½ inch wide thermal paper
- Full graphics at 60 dots/inch
- Interfaced to PET
- Works with all PET peripherals
- 40 character per second rate
- Microprocessor controlled
- Bidirectional look-ahead printing
- Quiet operation
- No external power supplies
- Only two driven parts
- High reliability
- Clear 5 x 7 characters
- Attractive metal and plastic case

The Skyles PAL-80™ is a high speed thermal printer offering the combination of text printing at 80 characters per line and continuous graphics at 60 dots per inch. In the text mode, upper and lower case data are printed at 40 characters per second. The 5 x 7 characters provide clear readable copy on white paper; no hard to find, hard to read aluminized paper.

In the graphics mode, seven bits of each byte correspond to the seven dots in each of the 480 print positions per line. Since the computer driving the printer has full control over every print position, it can print graphs, bar charts, line drawings, even special and foreign language symbols. Despite its low cost, the Skyles PAL-80 is a

true intelligent printer with full line buffering and bidirectional look-ahead printing.

High reliability is designed in: The thick film thermal print head has a life expectancy of 100,000,000 characters. Two DC stepping motors provide positive control of the print head and the paper drive.

The Skyles PAL-80 operates directly from a 115V 60 Hz line (230V 50 Hz available). No external power supplies are required.

It comes complete with an interface for the PET: a two and a half foot cable plugs into the IEEE interface at the back of your PET. Works with all PET models and PET or Skyles peripherals.

Please send me _____ Skyles PAL-80 printer(s) complete with 2½ foot interface cable to attach to my PET at \$675.00 each* (Plus \$10.00 shipping and handling). I also will receive a test and graphics demonstration tape at no additional charge and over 150 feet of 8½ inch wide black on white thermal paper \$ _____

I would also like to order _____ rolls of 8½ inch wide by 85 ft. long thermal paper (black ink) at \$5.00 each \$ _____

_____ 10 roll cartons at \$45.00 \$ _____

VISA, Mastercharge orders call (800) 538-3083
California orders call (408) 257-9140

*California residents add 6 to 6½% sales tax where applicable.

PAL-80 SPECIFICATIONS

TEXT

Format 80 characters per eight inch line
6 lines per inch nominal

Print speed 40 characters per second

Line Feed 50 milliseconds nominal

Character Set 96 Characters, including upper and lower case, numerals, and symbols

GRAPHICS

Format 480 print positions per line

Print Speed 240 print positions per second

COMMON

Paper 8½ inch wide thermal paper, available in 85 foot folls, black image on white

Dimensions 12"W x 10"D x 2¾"H

Weight 8 lbs (3.6 kg)

Skyles Electric Works

**231 E. South Whisman Road
Mountain View, CA 94041
(408) 735-7891**

at location 826. If you want your program to have a tape name, then in addition to step B above you must execute the following steps between step A and step B.

- B1) POKE the ASCII value of each letter of the name into the buffer beginning at location 826.
- B2) POKE238,N where N equals the number of letters in the name and press RETURN.
- B3) POKE249,58:POKE250,3 and press RETURN.

Now execute step C and your saved program will have a name. (You old ROMers got out light by not even having to perform hex/decimal conversion.)

If you stayed with me all the way through then you should have learned three new things about your PET. How to use the second cassette buffer for data storage, how to save programs using the Monitor, and how to protect your programs from being copied. There is one final hint about reducing program memory requirements I would like to pass along to those using the PROGRAMMER'S TOOLKIT. Before saving the final version RENUMBER the program in increments of 1 beginning at line 0. This will save you an average of two bytes for every line number referenced in any type of GOTO or GOSUB statement.

I'll be glad to answer any questions concerning your PET if you will include a SASE with your request. ©

P³ = Powerful PET Products

from

OPTIMIZED DATA SYSTEMS!

— AVAILABLE NOW —
(Prices include Shipping)

- WORD PROCESSOR \$16.95
Makes documents a snap
- MAILING LIST \$16.95
Throw away your address book
- SPACE EATER \$ 7.95
Gobbles spaces in BASIC programs
- CATALOG \$16.95
File stamp/coin collections
- SATELLITE TRACKER \$24.95
Tracks OSCAR Ham Satellite
- MORSE CODE KEYS \$14.95
Sends code for real or practice

— IN THE PIPELINE —

- More REAL WORLD SOFTWARE
- 2114 RAM ADAPTER
- LOW-COST MASS STORAGE
- INTELLIGENT KEYBOARD

WRITE FOR DETAILS — NOW!
P.O. Box 595, Placentia, CA 92670

(PET is a trademark of Commodore Business Machines)

MICRO COMPUTER INDUSTRIES, LTD.

INVENTORY CONTROL WITH POINT OF SALE FOR CBM AND PET 32K

DISK VERSION INCLUDES: Storage of 2500 items per diskette, Accounts Receivable, Writes Purchase Orders, Invoices, Summaries, Post Income and will Sort by 10 fields.

\$100.00

INVENTORY CONTROL 8K

CASSETTE VERSION INCLUDES:
Purchase Order program and Printing functions.

\$ 39.00

GENERAL LEDGER

DISK VERSION INCLUDES: The total functions of the Inventory Control programs plus; Accounts Payable, Notes Payable, Purchases, Expenses, it also issues complete Reports, Statements and Summaries.

\$350.00

Instruction Manual \$10.00 refundable with purchase.

MICRO COMPUTER INDUSTRIES, LTD.

1520 East Mulberry Suite 240
Fort Collins, Colorado 80524
1-303-221-1955

Computer House Div.

Announces

Programing Tools For the Commodore/Disk "SOF-BKUP"

Faster & Error Free Disk Copy
or Disks may be Merged

"FET/RECOVER"

File Editing Tool; Examine Data Files, Fix Destroyed
Pointers, Sectors may be Read, Modified, Displayed or
Written — Also Files may be Re-chained

"SUPER RAM"

Diagnostic Routine Checks Every Possible RAM
Address on 8K, 16K & 32K Commodore Computers

Available on Diskette right now.....

All for only \$105.00 retail

SOF-BKUP	\$40.00
FET/Recover	\$65.00
Super RAM.....	\$20.00

1407 Clinton Rd. Jackson, Mich. 49202
Telephone: (517) 782-2132

WORDPRO

BY

commodore

Typewriters have come a long way since they were first introduced into offices. They've evolved from heavy-handed apparatus into the time saving electrics first used in the Fifties. Now the typewriter is the center of sophisticated, and often costly, office information systems.

Today, Commodore Business Machines, Inc., a leader in personal business systems, provides you with a cost-effective alternative to complex, cumbersome and expensive information systems. The Commodore

WordPro system — convenient, simple word processing — meets the needs of the business office of the Eighties.

With Commodore's versatile WordPro system, the time and effort saving benefits of word processing are a proven reality. The affordable Commodore WordPro system incorporates many user-suggested features to make operation as simple — and enjoyable — as possible.

And, WordPro grows with your changing business and paperwork

demands, allowing you to add other functions as your business expands. All without extensive hardware investments.

WordPro by Commodore offers the same features as large word processing systems ... instant editing, global search and replace, full document retention up to 170 pages on-line and much more!

WORDPRO WORKS FOR YOU



commodore

See Your Authorized Commodore Dealer today for a WORDPRO Demonstration.

ENHANCING COMMODORE'S WORD PRO III

Larry Isaacs, COMPUTE Staff

This article will deal with enhancing WordPro III, as was done for WordPro II in the previous issue of COMPUTE. The enhancement is designed for those who are using WordPro III on a CBM, and are using the NEC Spinwriter for output. Most Spinwriter print thimbles have nine characters which normally can't be printed by WordPro III. The enhancement will allow you to embed special characters in your text that will print as one of the Spinwriter characters not accessible by WordPro III alone.

The special characters are entered in your text by hitting the ESC key followed by a number from 1 to 9. If some other key is struck following the ESC key, the normal character is entered. Also, the ESC key must be struck for each special character you wish to enter. The section on ASCII output shows the ASCII data which is output for each of the nine special characters. This section also shows the characters printed for two of the available print thimbles.

This article also has a section which discusses how to make modifications. This section will cover both the enhancement presented in this article as well as the enhancement presented in the previous COMPUTE. for WordPro II. One of the areas discussed is the modification necessary to use the enhancements on PETs with graphics keyboards. These PETs don't have an ESC key (or the REPEAT key used by the WordPro II enhancements).

The Upgrade Procedure

The two machine code patches presented here are for WP3 (FEB 5), the current production version of WordPro III. These patches will be entered using the machine language monitor in the PET. Commands in this section for the machine language monitor begin with a period. This period is a prompt character printed by the monitor. To execute one of these commands, just type the rest of the command and hit RETURN.

Before entering the patches, first place the work copy of your WordPro diskette in drive 0 and initialize the diskette. Now type SYS1024 plus carriage return to get into the machine language monitor. Execute Command 1, and enter the first patch using the PET's screen editor to change the displayed memory to what is shown beneath the command. Be sure to hit a carriage return when you reach the end of each line. The carriage return causes the changes to be

placed in memory. Once you have finished the first patch, enter the second patch using the same procedure for Command #2. Now execute Commands #3 and #4 to save the patches on disk.

Command #1. **M 05C0 064C**

```
.
.: 05C0 00 00 00 00 00 00 20 CC
.: 05C8 05 4C 02 06 BA BD 06 01
.: 05D0 8D C2 05 09 04 9D 06 01
.: 05D8 BD 07 01 8D C0 05 BD 08
.: 05E0 01 8D C1 05 18 68 69 01
.: 05E8 9D 07 01 68 69 00 9D 08
.: 05F0 01 4C 55 E4 AD C2 05 48
.: 05F8 AD C3 05 AE C4 05 28 6C
.: 0600 C0 05 8D C3 05 8E C4 05
.: 0608 A6 9E F0 E8 BD 6E 02 C9
.: 0610 1B F0 14 4E C5 05 90 DC
.: 0618 C9 3A B0 D8 C9 31 90 D4
.: 0620 09 80 9D 6E 02 D0 CD CA
.: 0628 A9 01 8D C5 05 86 9E D0
.: 0630 C3 78 A9 C6 85 90 A9 05
.: 0638 85 91 A9 4C 8D E3 36 A9
.: 0640 E0 8D E4 36 A9 43 8D E5
.: 0648 36 58 4C D7 14 AA AA AA
```

Command #2. **.M 43E0 442F**

```
.
.: 43E0 C9 5B 10 03 4C E7 36 C9
.: 43E8 71 90 37 C9 7A B0 33 A6
.: 43F0 27 F0 0C 48 A9 5F 20 3D
.: 43F8 2E A9 08 20 3D 2E 68 29
.: 4400 0F AA E0 08 10 09 BD 25
.: 4408 44 20 3D 2E 4C 35 37 A9
.: 4410 0E 20 3D 2E BD 25 44 20
.: 4418 3D 2E A9 0F 20 3D 2E 4C
.: 4420 35 37 4C F3 36 00 5E 5C
.: 4428 60 7B 7D 7C 7E 58 5A 00
```

Command #3 **.S "0:PATCH 1",08,05C0,064D**

Command #4 **.S "0:PATCH 2",08,43E0,4430**

This completes the upgrade procedure. If you want to return to BASIC, type "x" plus carriage return. To run an upgraded WordPro III, place the diskette containing the patches in drive 0, and execute Commands #5 through #9 in sequence. If you find that your enhanced WordPro won't come up or operates improperly, it's likely you've made an error in the first patch (the one with Command #1). If it runs and you are able to enter the special characters, but fouls up when you try to print something, you've likely made an error in the second patch.

Command #5 **OPEN1,8,15,"I0"**

Command #6 **LOAD "WP3(FEB 5)",8**

Command #7 **LOAD "PATCH 1",8**

Command #8 **LOAD "PATCH 2",8**

Command #9 **SYS1585**

The ASCII Output

Table 1 shows the ASCII data that is output for each of the special characters. Notice the Spinwriter requires a three code sequence for two of the characters on the print thimble. Also given in the table are the characters printed for two of the thimbles. One is the Courier 10, which has a standard ASCII character set. The other is the Courier Legal 10B, which has some legal symbols substituted for some of the standard ASCII characters.

Modifying The Patches

Though the machine code patches are different, the enhancements for WordPro II and III operate almost identically. To cover modification of both enhancements, I will reference WordPro III modifications directly and put the corresponding reference for WordPro II in brackets.

First let's look at what needs to be changed to use the enhancement with a graphics keyboard. At one point in the patch code the last keystroke in the keyboard input buffer is checked to see if it is \$1B [\$7F for WP2], which is the code for the ESC [REPEAT] key. To change the key just change the byte used in the comparison. This byte is the first byte in the line that begins at address \$0610 [third byte of the line that begins at address \$028A]. Changing this byte to \$DE will allow you to use a shifted uparrow instead.

Next, let's look at changing the ASCII data output for the special characters. This will allow you to use a different printer and possibly change the function of the enhancement. The patch code that handles the output checks each character to be printed if it is in the range \$71 to \$79. Only the special characters used by the enhancement will be in this range. If a special character is found, the most significant four bits are discarded, and the least significant four bits used as an index to a table. The table begins with the sixth byte of the line with address \$4420 [first byte of the line with address \$3FD5]. The first byte would be output for a special character with the value \$70. Currently this value isn't used so the byte is \$00. The next byte would be output for a character with the value \$71, and so forth up to \$79. The data in this table may be changed to whatever you require.

It may be necessary to also change which special characters output the three code sequence. Once a special character has been detected and its index obtained, that index is compared with the third byte of the line with address \$43F8 [second byte of the line with address \$3FBD]. If the index is equal to or greater than this byte, the three code sequence is used. Changing this byte to \$0A would cause all the special characters to output only the data byte in the table. To change the first and third characters used in the sequence, set the first byte of the line with address \$4410 [seventh byte of line with address

\$3FC5] to the first character of your sequence, and the fourth byte of the line with address \$4418 [second character of line with address \$3FD5] to the third character of your sequence.

One other modification is to add a special character for the 0 key. To do this, change the sixth byte of the line with address \$0618 [last byte of the line with address \$0292] to \$30, and the first byte of the line with address \$43e8 [seventh byte of the line with address \$3fad] to \$70. Then put the byte you want to be output in the first byte of the table.

The above extension was prompted by feedback from readers wanting to adapt the WordPro II enhancement for use with a different printer. Hopefully the discussion will be sufficient for most situations. If you do make mods for another printer, please send them to COMPUTE. so we can pass along to other readers.

TABLE 1

Special Character	ASCII Characters	Thimble Character Printed	
	(Hex) Output	Courier 10	Courier Legal 10B
1	5E	^	⊙
2	5C	\	⊙
3	60	`	⊙
4	7C		¶
5	7D	{	§
6	7B	}	†
7	7E	~	™
8	0E,58,0F	⌞	⌞
9	0E,5A,0F	£	⌞

Reproduce and Attach Above Numeric Pad

7=˘	8=⌞	9=£
4=	5={	6=}
1=^	2=\	3=`

7=™	8=⌞	9=
4=¶	5=§	6=†
1=⊙	2=⊙	3=⊙

CBM CERTIFIED
In-House Maintenance

DOWNEY, CA.
(213) 923-9361

ALL UNDER ONE ROOF
29 years
Serving Computer Centers

FAMILY OWNED & OPERATED
(even "no-relation" associates are family)

DES

Data Equipment Supply Corp.
8315 Firestone Blvd., Downey, CA 90241



\$OLID GOLD \$SOFTWARE®

DES's own—2 years preparation! Writing, testing and updating to be sure our software deserves this label.

- **FULL ACC'T. PACKAGE** \$1600.00
ACC/SYS GA 104 (32K) 9 DISKS
For accountants & small businesses
(Sold locally only for now—to give customer full support)
- **LAWYERS Package #1** (32K) Disk... \$1200.00
63 Attorneys, 5200 clients (200 matters ea)
Prelim & Final Statements, Aging, Mgmt Rpts
- **CHEMISTRY PROFILE** (16K) \$350.00
A blood analysis program that yields a diagnosis based on 29 blood tests (high-normal-low)
- **MLS** (32K min.) Disk \$1200.00
(Property avail, sold, by city & zone, mg'mt analyst rpts, buyer & seller rpts, etc.)

"GOLD PLATED \$SOFTWARE®"

SPORTS

- **HOCKEY #1** (Disk) \$29.95
Compiler for hockey statistics—excellent for team and league managers. (When tested on a 17 team league SAVED 20 hours a week of record keeping)
- **BASEBALL #1** (see Hockey) (Disk) \$29.95

BUSINESS

- **MAILING LIST 1.0** (16K min.) \$29.95
Maintains file and printout
- **MAILING LIST 2.0** (16K min.) \$49.95
More powerful plus file merging
- **SUPER LIST** (8K min.) \$19.95
(Advanced listing features)
- **CALENDAR** (8K min.) \$19.95
(Perpetual calendar with printout)
- **PHONE MAIL SYSTEM** (16K min.)... \$49.95
CBM Printer (Word processing plus phone book)

EDUCATIONAL

- **FLASH CARDS** (16K min.) \$24.95
Multi "user input" quiz - great study aid
- **MATHEMATICS** (8K min.) \$7.95 ea
A) Add B) Subt C) Multi D) Div
- **"BRANDI'S SPELLING BEE"** (8K min)... \$9.95
(SUPERB Aid Pre-School - 2nd)
- **VISUAL PERCEPTION** (8K min) \$7.95
Shapes & Sizes
- **CONSONANT BLENDS** (8K min) \$7.95
2 letter sound combinations
- **COUNTING 1 to 9** (8K min) \$7.95
Visual - tutorial

GAMES

- **MAY 1941** (8K min.) \$24.95
Simulated tracking & sinking of the Bismarck
- **SIMON** (8K min.) \$7.95
Duplicates the numbers & sounds selected
- **GUESS??** (8K min.) \$7.95
Full graphic sound, guessing game

★ "The Finest Software Crew in the World" ★

Mike Richter/Norm & Brad Hanscom/Sy Elsayess
David Schwartz/Donna Schlieper/Bob Johnson
Dave Lundberg/Murat Kalinyaprak/Henry Kluka

SUPPLIES

(WE PLAN, WITH OUR PRICES, TO CORNER THE MARKET!)
DISKETTES (FLOPPIES)

- BASF (5¼" & 8") \$2.90 ea.
- MEMOREX (5¼" & 8") 2.90 ea.
- WABASH (8") 2.65 ea.
- DYSAN (5¼" & 8") 4.90 ea.

CASSETTES (Digital & Audio)

- BASF (C30 - .90¢; C60 - \$1.20; C90 - \$1.50; C120 - \$1.75)
- KEYLINE (Digital Only) \$5.75

RIBBONS

- CENTRONICS**
- 101 & 301 \$6.15
- TALLY (2100 & 2200) \$3.95
- DIABLO

- Hy Type I \$4.00 & up
- Hy Type II \$5.00 & up
- TELETYPE #2, #13 (use on CBM) \$2.95
- QUME \$3.95
- PRINTRONICS \$10.25
- DEC LA30 - \$4.25 / LA180 \$5.25

PRINTER PAPER (✓ us for case prices)

- 9½ x 11 (perfs to 8½ x 11) 500 shts. \$7.95
- 14¾ x 11 500 shts \$9.95

Your Complete
Computer Center

—SEND FOR DESCRIPTIVE BROCHURES—
ALL AVAILABLE ENGLISH/ARABIC

DES DATA EQUIPMENT SUPPLY CORP.
8315 Firestone Blvd., Downey, CA 90241
(213) 923-9361

PAYMENT (Calif. Residents add 6% Sales Tax)

CHECK # _____

VISA

MASTERCARGE Exp. Date _____

Acct. # _____

Name _____

Address _____

City _____

State _____ Zip _____



Skyles Electric Works

Presenting the Skyles MacroTeA

The Software Development System For the Professional Programmer and The Serious Amateur Software Hobbyist

...and for anyone who needs to automate dedicated industrial measurement and control applications.

The Macro TeA, designed for use with the Commodore PET to create a remarkable synergism: a complete, integrated software development system for the 6502...the only 6502 system not requiring a separate disk drive. With over 60 commands for your complete machine language programming.

...a lightning fast...fast...fast.....
....machine language assembler with true macro capabilities. Assemble 16K source text in less than ten seconds! A single name indentifies a whole body of lines. Macro and conditional assembly support. Automatic line numbering. Labels up to ten characters long; 10¹⁶ different labels.

```
ASSEMBLE LIST
0100 .MOVE TBL 1 TO TBL2
0110 .BA $400
0400 - A0 0B 0120 LOOP LDY #00
0402 - B9 0B 04 0130 LDA TBL1.Y
0405 - 89 0B 05 0140 STA TBL2.Y
0408 - C0 0150 INY
0409 D0 F7 0160 BNE LOOP
0170
040B 0180 TBL1 DS 256
050B 0190 TBL2 DS 256
0200
0210 EN
LABEL FILE 1 = EXTERNAL
START = 0400 LOOP = 0402 TBL1 = 040B
TBL2 = 050B
110000,060B,060B
```

Install permanently without tools and in less time than it takes to load an equivalent sized assembler/text editor program from tape. No tape loading ever. And no occupying of RAM memory space: the MacroTeA puts 10K of executable machine language code in ROM(9800 to BFFF) and 2K in RAM (9000 to 97FF).

...a super powerful text editor. 26 commands with string search and replace capability. Manuscript feature. Test loading and storage on tape or disks. Supports tape drives, disks, CRT, printers and keyboard.

...an enhanced monitor with 11 powerful commands for program debugging and final polishing.

...with a warm-start button, on a 12 inch cable. Reset the PET but not the 1792 bytes of object code in the Macro TeA RAM memory.

...a completely solid state firmware system ...all in ROM and RAM. No tapes to load. The system is available from the time you turn on your PET to the time you shut it off.

15 chips on a single high quality printed circuit board; interfaces with PET's parallel address and data bus or with Skyles Memory Adapter. A comprehensive 170 page manual is included

Truly, there is simply no other system of this magnitude at anywhere near this price. **\$395.00 ***

(With any Skyles Memory Expansion System, \$375.00)

**California residents: please add 6% or 6.5% sales tax as required*

VISA, MASTERCARD ORDERS CALL (800) 538-3083 (except California residents)
CALIFORNIA ORDERS PLEASE CALL (408) 257-9140



Skyles Electric Works

231 E South Whisman Road
Mountain View, CA 94041
(408) 735-7891

Machine Language Tools

Jim Butterfield

The newcomer to machine language programming will need to provide himself with certain tools before he gets started.

It's important to have the right computer. The original ROM which came with early PETs can be used with machine language, but it's clumsy for this kind of use. If you haven't done so already, make the switch to upgrade ROM: you'll get a built-in Machine Language Monitor and the capability to dig your way out of a program crash.

Get the official reference: **6502 Programming Manual**. It may be obtained from Commodore (MOS Technology), Synertek or Rockwell, who are the three manufacturers of 6502 microprocessors. It's not a teaching book, but a reference - although many of the early chapters are set out in tutorial style.

If you see other books that seem to suit your needs, you may buy them, of course. Avoid books that deal with "somebody else's" machine - you won't learn much about the PET from books on KIM, SYM, Apple, OSI, AIM or Atari. At a later stage, you might like to buy such books in order to try your hand at converting the programs to PET - or just to get an idea as to what's in other machines.

General books on the 6502 are good. Remember that you'll have to fit what these books say into the framework of the PET architecture. Leventhal's **6502 Assembly Language Programming** (Osborne/McGraw Hill, Inc.) is full of programming examples; but they will all need to be trimmed up to fit the PET. Don't let that worry you - it's not hard, and it's good practice.

You have very little need for hardware unless you have a special project in mind. If your machine has upgrade ROM, try building or buying an un-crashing connector (see COMPUTE, issue 1, page 89). Your early programs will certainly "crash" and you'll save a lot of reloading or retyping if you can re-awaken your machine. Most non-PET machines have a Reset button that will do the same job, which is very convenient except when you hit it accidentally.

The Machine Language Monitor is very useful. It's built into upgrade ROMs. Original ROM machines can load a MLM from tape, but this is much less convenient especially since it uses up memory space that you might want for your own purposes. You may enhance the usefulness of your MLM by obtaining more elaborate versions. Many of these are available from the PET Programs On Tape Exchange (P.O. Box 516, Montgomeryville, PA 18936). (*Editor's Note: See Table of Contents. RCL*)

If you're staying with original ROM, you might like Bill Seiler's NEWMON which has many

extra functions including a tiny assembler. Another useful package is Jim Russo's high monitor with machine language single-step; this is sometimes called MT6671 and sometimes DISS/STEP.

The upgrade ROM monitor is built in, but there are a couple of enhancement packages that add extra functions: SUPERMON and EXTRAMON. Both of these contain powerful extras: disassembler, tiny assembler, memory hunt, and single-stepping.

If you get deeply into machine language programming, you'll want to obtain a full assembler. These are available from commercial sources. Don't get an assembler right away, especially if you're thinking of adding memory or a disk system. Your beginning programs will be quite small, and easy to hand assemble; what's more, you'll get a better feel for how the machine works by doing it all yourself. Later, as your programs start to exceed thirty lines of code or so, you'll find that an assembler will be a big help. This is especially true when you want to make changes to a previously written program. Since few of us write perfect programs every time, the capability of making changes easily is a major advantage that assemblers give you.

The most important tool you need for machine language programming is one you've already got: your brain. Remember that each machine language instruction is simple and logical; a program gets complex only when you put many instructions together. Be prepared to change your style when you go to machine language; a lot of thinking and planning should take place before you write your first line of code.

If bits and logical operations are not familiar to you, you'll need to do some advance brushing up. Learn why you can store values only from 0 to 255 in a memory location; how a negative number is represented in binary; how to relate binary, hexadecimal and decimal numbers; and how the logical functions (AND, OR, and EOR) work. There are plenty of introductory texts around to help. ©

Algebraic Input for the PET

Harvey Davis
Department of Mathematics
Michigan State University

One of the first experiments that I made when I started using the PET was to input the character "π" as a numeric value. Of course it failed. But the possibility of inputting general expressions such as $2*\pi*A$ and $SQR(2 + A*B)$ has always been a dream of mine. The following program allows one to do just that.

The heart of the program is the subroutine beginning at line 20. After an algebraic expression has been inputted as X\$, line 30 clears the screen and prints a line such as

$$X = \text{SIN}(A*B + \pi)$$

at the top of the display. Lines 35 and 36 print the command CONT at the beginning of the 4th and 5th lines on the screen. If after this was done the user would STOP the program from the keyboard and then type the sequence [HOME], [RETURN], [RETURN] the computer would evaluate the expression and then continue the program where it had left off. (The second CONT is there in case the expression overflowed onto the second line.)

Many users have noticed that stopping a program causes the PET to print the contents of the key stroke buffer onto the screen. See, for example the article "Dynamic Keyboard" by Mike Louder dated July 7, 1978 and appearing on page 7 of the Pet User's Group Newsletter volume 0, number 4.

Mr. Louder writes: "The decimal addresses for the keyboard buffer are 527 through 536. The buffer counter address is 525.

"If a BASIC program is interrupted with a STOP or END the keyboard monitor searches the keyboard buffer and executes any 'ASCII' instruction that may have been typed in while the program was running."

Mr. Louder goes on to explain how this characteristic of the PET may be used to modify programs and add a computed GOTO to the user's arsenal of techniques. The following technique is similar to his computed GOTO except that it causes an expression to be evaluated and a continue to be executed.

Line 40 sets the buffer counter index at 3 which tells the computer that there are three characters in the buffer. Line 45 loads the ASCII values of the commands [HOME] (= 19) and [RETURN] (= 13) into the keyboard buffer. When the program is stopped at line 50 these commands are executed, forcing an evaluation of the expression at the top of the display and then the execution of the CONT command. The computer then continues running and all variables, including the new value for X are intact. A simple pro-

gram is provided at line 100 calling this subroutine so that the reader may experiment with it.

Finally a word of caution. If the expression has a syntax error in it, the program must be run from the beginning and all variables will be lost.

As a postscript I would like to post the following questions:

1. Can the above process be done without the disconcerting writing to the screen, possibly by momentarily convincing the PET that the screen is somewhere else?
2. As mentioned above, programs can be dynamically updated. Can they be updated in such a way as to leave the variables undisturbed? This would be quite useful in programs that work on functions such as plotters and integrators.

PROGRAM LISTING

```

10 Q$=CHR$(34):GOTO100
20 PRINT"[CLR][DN][DN][DN]";
21 PRINT"X MAY BE ANY EXPRESSION"
25 INPUT"[HM]X=";X$
30 PRINT"[CLR]X=";X$
35 PRINT"[HM][DN][DN][DN]CONT"
36 PRINT"CONT"
40 POKE525,3
45 POKE527,19:POKE528,13:POKE529,13
50 STOP:RETURN
60 PRINT"[CLR][DN][DN][DN]";
61 PRINT"A,B AND C MUST BE NUMBERS"
65 INPUT"[HM]A,B,C=";A,B,C:RETURN
100 REM SAMPLE MAIN PROGRAM
110 GOSUB60:GOSUB20
120 PRINT"[CLR]"
125 PRINT"IF X=";X$:PRINT
130 PRINT"    AND A=";A
131 PRINT"    B=";B
132 PRINT"    C=";C:PRINT
133 PRINT"    THEN X=";X:PRINT
135 PRINT"TYPE ";Q$;"N";Q$;
136 PRINT"FOR NEW VALUES OF A,B,C"
137 PRINT"    ";Q$;"X";Q$;
138 PRINT"FOR A NEW EXPRESSION"
139 PRINT"    ";Q$;"B";Q$;
140 PRINT"FOR BOTH"
141 PRINT"    ";Q$;"E";Q$;
142 PRINT"TO END THE PROGRAM"
150 GET A$:IF A$=""GOTO150
155 IF A$<>"N"GOTO160
156 GOSUB60:GOSUB30:GOTO120
160 IF A$="X"THENGOSUB20:GOTO120
165 IF A$="B"THENGOTO100
170 IF A$="E"THEN END
190 GOTO120

```

PET DATA COPIER

Ron Straley
1868 Grade Ave.
Ft. Myers, Fla 33901

Having written and used many programs that use data files, I know the value of having backup tapes in case of an accident.

Here is a program I wrote to solve my problem, and maybe it will help others in their line of program running save time and trouble.

It is a data tape copier for the 'PET' computer that will copy any 'PET' data file or data tape so you will have a backup data copy.

```

20 REM          BY
30 REM          RON STRALEY
40 REM          1868 GRACE AVE.
50 REM          FT.MYERS,FLA.33901
60 REM
100 PRINT"ÂTHIS IS A DATA TAPE COPY -
    -PROGRAM."
110 PRINT:PRINT"IT WILL COPY UP TO 450 -
    -STRINGS.":PRINT
120 PRINT"TO CHANGE, REDIMINSION'DS'IN -
    -LINE 170":PRINT:PRINT"AND'M'IN -
    -LINE190.
130 PRINT:PRINT:PRINT"****INSERT DATA -
    -TAPE TO BE COPIED****"
140 :
150 REM**READ IN DATA TAPE**
160 :
170 CLR
180 DIMD$(450)
190 T=128:F=64
200 M=450
210 PRINT:PRINT:PRINT"DOES DATA TAPE -
    -HAVE FILE NAME?(Y OR N)"
220 GETA2$:IFA2$=""GOTO220
230 IFA2$="Y"GOTO260
240 IFA2$="N"GOTO280
250 GOTO210
260 PRINT:INPUT"DATA TAPE FILE NAME?";
    -A1$
270 OPEN1,1,0,A1$
280 OPEN1,1,0
290 A=0:PRINT"Â"
300 INPUT#1,D$(A)
310 IF(ST=T)ORST=FTHEN370
320 A=A+1
330 D$(A)=A$
340 PRINT"Â          WORKING"
350 IFA<MTHEN300
360 :
370 REM*END OF FILE (64) OR TAPE (128)*
380 CLOSE1
390 :
400 REM**WRITE NEW DATA TAPE**
410 :
420 PRINT"ÂREMOVE TAPE TO BE COPIED."
430 PRINT:PRINT"NOW INSERT CASSETTE TO -
    -COPY TO IN DRIVE#1"
440 PRINT:PRINT"PRESS ANY KEY"
450 GETB$:IFB$=""GOTO450
460 IFA2$="Y"GOTO480
470 IFA2$="N"GOTO490
480 OPEN1,1,1,A1$:GOTO500
490 OPEN1,1,1
500 IFA=0THEN570
510 FORI=1TOA
520 A1$=D$(I)
530 :
540 GOSUB830:REM**WRITE ROUTINE**

```

It has provisions in it to input a file name if your tape has one or else just copy a plain data file or tape.

The program has full prompts on the screen. There is also a routine to let you look at what is written on your new data tape. It can display all of your data on the screen. This is an operator selected routine.

Line 100 is start of data tape to copy load routine.

Line 430 is start of new data tape write routine.

Line 630 is start of read and display of new data tape routine.

Line 960 is cassette advance routine for space between blocks.

```

550 :
560 NEXTI
570 CLOSE1
580 PRINT"ÂDATA TAPE NOW COPIED"
590 :
600 REM*READ NEW DATA TAPE TO VERIFY*
610 :
620 CLR:PRINT
630 PRINT"DO YOU WISH TO READ AND -
    -DISPLAY NEW DATA";:PRINT
640 PRINT"TAPE? (Y OR N)"
650 GETB$:IFB$=""GOTO650
660 IFB$="N"GOTO1020
670 IFB$<>"Y"GOTO600
680 PRINT"ÂREWIND TAPE,THEN PRESS ANY -
    -KEY"
690 GETB$:IFB$=""GOTO690
700 DIMD$(450):T=128:F=64
710 OPEN1,1,0
720 A=0
730 INPUT#1,A$
740 PRINTA$:FORJ=1TO150:NEXTJ
750 IF(ST=T)ORST=FTHEN780
760 A=A+1
770 GOTO730
780 CLOSE1
790 PRINT"THATS ALL THE DATA I CAN -
    -FIND."
800 PRINT:PRINT"PRESS ANY KEY TO COPY -
    -NEXT FILE OR DATA TAPE"
810 GETA$:IFA$=""GOTO810
820 GOTO100
830 REM**WRITE ROUTINE**
840 :
850 T1=TI:IFLEN(A1$)<190THEN900
860 PRINT#1,LEFT$(A1$,189);
870 IFTI-T1>120THENGOSUB940
880 T1=TI:PRINT#1,RIGHT$(A1$,LEN(A1$)-18
    -9)
890 GOTO910
900 PRINT#1,A1$
910 IFTI-T1>120THENGOSUB940
920 RETURN
930 :
940 REM**CASSETTE ADVANCE**
950 :
960 POKE59411,53:T1=TI
970 IFTI-T1<6THEN970
980 POKE59411,61:RETURN
990 :
1000 REM** ANY MORE COPIES? " **
1010 :
1020 PRINT:PRINT"ÂDOYOU WISH TO COPY -
    -ANY MORE DATA FILES"
1030 PRINT:PRINT"OR DATA TAPES? (Y OR -
    -N)"
1040 GETB$:IFB$=""GOTO1040
1050 IFB$="Y"GOTO100
1060 IFB$<>"N"GOTO1020
1070 END

```

LOOK at all the MICRO-ED programs for the PET!

A Major Drill and Practice SPELLING SERIES

To Supplement Regular Classroom
Instruction

Five levels—A, B, C, D, E—cover grades 2 through 6. Complete set consists of 35 tapes with a total of 180 lessons. Each level has seven tapes containing thirty-six lessons.

LEVEL A

7 tapes, 36 lessons, grade 2. . \$49.95

LEVEL B

7 tapes, 36 lessons, grade 3. . \$49.95

LEVEL C

7 tapes, 36 lessons, grade 4. . \$49.95

LEVEL D

7 tapes, 36 lessons, grade 5. . \$49.95

LEVEL E

7 tapes, 36 lessons, grade 6. . \$49.95

ENTIRE SPELLING SERIES

\$225.00

A SAVINGS OF \$24.00.

WORD DEMONS

2 tapes—\$14.95

Tape one: There-Their-They're. Tape two: To-Too-Two

USAGE BONERS

15 tapes—\$99.00

This drill and practice series focuses on common mistakes in usage, such as agreement between subject and verb, double negatives, etc.

ANY INDIVIDUAL TAPE CAN BE
PURCHASED FOR \$7.95.

MICRO-ED's
main author is
Thorwald Esbensen
named in 1980 as
one of North
America's top school
executives by
*Executive Educator
Magazine.*

*"I have seen
programs by Mr.
Esbensen, and he
does a wonderful
job of making them
both instructional and
interesting for children."*

—Len Lindsay,
Microcomputer
Author

SEND FOR FREE BROCHURES FROM
**MICRO-ED
INC.**

P.O. Box 24156
Minneapolis, MN 55424

MICRO-DOZEN ONE

- **COUNT 'EM** (Kindergarten and 1st grade) The learner counts from one to ten steam locomotives on the computer screen.
- **Story Problems in Addition and Subtraction** (Elementary) An assortment of story problems in addition and subtraction, many of which involve lords and knights and a great castle.
- **What Number is Missing?** (Kindergarten, 1st grade) Digits from one to nine appear in sequence. But one digit is always missing. Which one?
- **Tachistoscope** (Elementary) Groups of words are flashed on the screen. The student must reproduce them correctly at the computer keyboard.
- **Identifying Complete Sentences** (Elementary) Groups of words are presented on the screen. Which ones are complete sentences?
- **Lines and Spaces of the Treble Clef** (Elementary and up) Using whole notes with sound, the computer teaches the student the names of the lines and spaces that make up the treble clef.
- **Matching Capital Letters** (Pre-school and kindergarten) Large capital letters appear on the screen. What letters on the computer keyboard match them?
- **Which Letter Comes Next?** (Primary) A large capital letter appears on the screen. What letter comes next in alphabetical order?
- **Haiku** (Elementary and up) The computer writes poetry which it revises, line by line, upon request. This program can be used to help students write creatively.
- **Trail West** (Elementary) A journey to the goldfields of the Old West.
- **Direction and Distance** (Elementary) A game to teach the directions of North, Northeast, Southwest, etc.
- **Math Bid** (Elementary) An achievement motivation game, involving practice in addition, subtraction, multiplication, and division.

12 TAPES—\$84.00

Plus! ALL NEW from MICRO-ED! MICRO-DOZEN TWO

- **AGREEMENT OF SUBJECT AND VERB (Elementary and up)**
Problems consist of sentences with missing verbs. Two verb choices (singular and plural) are provided for each problem. The learner types the correct form of the verb.
- **RUN-ON SENTENCES (Elementary)**
Each problem consists of a group of words that should be divided into two sentences. Using the space bar, the learner moves an arrow across the screen and places it after the word that should end the first sentence.
- **MAKE A SENTENCE (First Grade)**
Some scrambled words appear on the screen. The learner must use some of these words (but only these words) to type a complete sentence.
- **MORE WORD DEMONS: ITS-IT'S-YOUR-YOURE (Elementary and up)**
Each lesson consists of twenty problems. There are sentences with blanks to be filled by the appropriate homonyms. At the end of the lesson, the learner's performance is summarized. Among other things, this summary lists the specific homonyms that may have given the learner trouble during the lesson.
- **HIGHER, SAME, LOWER (Elementary Music)**
Each lesson consists of ten problems in which two notes are played. Is the second note higher than, lower than, or the same as the first note? Each pair of notes is randomly selected from a bank of sixty-seven pairs.
- **MATCHING RHYTHMS (Elementary Music)**
The computer randomly selects one of ten rhythmic patterns and plays this as it displays matching quarter notes and eighth notes on the screen. The learner attempts to match the rhythm by pressing the space bar.
- **TARGET MATH (Elementary)**
The learner selects problems in addition, subtraction, multiplication, or division at a difficulty level of his/her choice. A target area appears at the bottom of the screen, along with a math problem. When the learner types an answer, a plane flies over and a parachute jumper floats down over the landing strip. If the jumper hits the target area, the next problem is presented.
- **WORKING WITH BASIC MULTIPLICATION FACTS (Elementary)**
Each lesson consists of fifteen problems. If the learner wishes, he/she may practice multiplying by a certain number. Problems are posed at random and are not repeated unless they are missed.
- **WORKING WITH BASIC ADDITION FACTS (Primary Grades)**
Each lesson consists of fifteen problems. If the learner wishes, he/she may practice adding only a certain number. Problems are posed at random and are not repeated unless they are missed.
- **ADDING OR SUBTRACTING TWO-AND-THREE-PLACE NUMBERS IN COLUMNS (Elementary)**
This program presents addition or subtraction problems using two-and-three-place numbers in columns. The learner works with each problem beginning with the units column on the right, (as would be done with paper and pencil) and moving left as guided by an arrow displayed under the appropriate column.
- **SUBTRACTING WITH OBJECTS (Primary Grades)**
Each lesson presents ten randomly generated subtraction problems with numbers from one to ten being subtracted from each other. Small arrows and diamond shapes represent this operation.
- **ADDING WITH OBJECTS (Primary Grades)**
Each lesson presents ten randomly generated addition problems with sums up to twenty. Small diamond shapes representing the numbers to be added appear on the screen.

All 12 Tapes for \$84.00

AVAILABLE this SUMMER

- Synonym Series
- Punctuation Series
- Reading Racer Series
- Vocabulary Series

Details concerning these new series available upon request.
We welcome suggestions for educational programs.

PET TWO-WAY RS-232 and PARALLEL OUTPUT INTERFACE

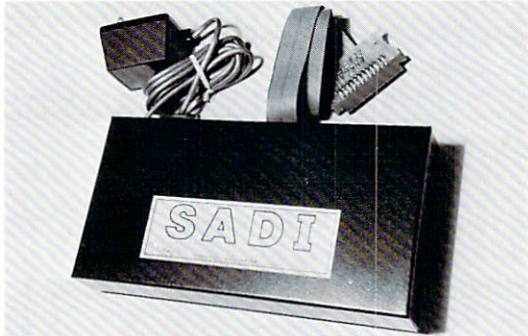

SADI - The microprocessor based serial and parallel interface for the Commodore PET. SADI allows you to connect your PET to parallel and serial printers, CRT's, modems, acoustic couplers, hard copy terminals and other computers. The serial and parallel ports are independent allowing the PET to communicate with both peripheral devices simultaneously or one at a time. In addition, the RS-232 device can communicate with the parallel device.

Special Features for the PET interface include:

- Conversion to true ASCII both in and out
- Cursor controls and function characters specially printed
- Selectable reversal of upper and lower case
- PET IEEE connector for daisy chaining
- Addressable - works with other devices

Special Features for the serial interface include:

- Baud rate selectable from 75 to 9600
- Half or full duplex
- 32 character buffer
- X-ON, X-OFF automatically sent
- Selectable carriage return delay

Special Features for the parallel interface include:

- Data strobe - either polarity
- Device ready - either polarity
- Centronics compatible

Complete with power supply, PET IEEE cable, RS-232 connector, parallel port connector and case. Assembled and tested.

SAD1a (110VAC) \$295
SAD1e (230VAC) \$325

Order direct or contact your local computer store.

CONNECTICUT microCOMPUTER, Inc.
150 POCONO ROAD
BROOKFIELD, CONNECTICUT 06804
TEL: (203) 775-9659 TWX: 710-456-0052

VISA AND M/C ACCEPTED - SEND ACCOUNT NUMBER, EXPIRATION DATE AND SIGN ORDER.
ADD \$3 PER ORDER FOR SHIPPING & HANDLING - FOREIGN ORDERS ADD 10% FOR AIR POSTAGE.

OHIO SCIENTIFIC EXPANSION INFORMATION

Conversion of C1P (Cassette) to 52x26 display. Detailed step-by-step instructions for doubling the C1P speed and display size!
Order Bulletin 1105 **\$12.00**

Conversion of C1P (Minifloppy) to 52x26 display. Same as above but includes display driver for disk operating system.
Order Bulletin 1105MF **\$20.00**

Conversion of C2-4P or C2-8P to 8 in. or 5-1/4 in. floppy. Instructions and schematics for converting cassette-based units into floppy systems.
Order Bulletin 1106F **\$20.00**

OHIO SCIENTIFIC EXPANSION ACCESSORIES

We have Ohio Scientific boards, cables, schematics, and documentation. Hard-to-find items:

Most Bare Boards **\$39.00**
430 Super I/O Board (Bare) **\$69.00**
Data Separator for MPI Minifloppy **\$25.00**
470 Universal Disk and Real-Time Clock Board (Tested) **\$295.00**
Dual Mini-Floppy Breakout Cable **\$34.50**
CP1 to S-44E Bus Converter **\$39.95**
Ohio Scientific Price List **FREE**

TRS-80 DISK EXPANSION

New do-it-yourself TRS-80 expansion board has floppy controllers, quiet 32K RAM, serial RS-232, parallel printer ports, active termination. Super documentation. Software compatible, by LNW Research.

Bare Board and Manual **\$89.95**
Manual Only **\$ 6.95**

New Book: "TRS-80 Disk and Other Mysteries" by IIG Computer Services. Essential reference manual for TRS-80!
130 pages. **\$22.50**

ELPACK

Components and Kits for Electronics and Science

ELPACK "STAR WARS" SOUND EFFECTS BOARD

A universal circuit board that uses the TI SN76477 Sound Effects Generator IC. Birds, dogs, space sounds, etc.
Bare Board and Manual **\$ 8.95**
Kit and Manual **\$24.95**
Manual Only **\$ 1.00**
ELCOMP Book: "Complex Sound Generation Using TISN76477," by Texas Instruments. **\$6.95**

ELPACK PRINTER CONTROLLER BOARD

A universal circuit board that uses the CY-480 Printer Controller IC to drive most 40 and 80-column printer mechanisms! Includes power supply. RS-232 input.
Bare Board and Manual **\$69.50**
Manual Only **\$ 5.95**

ELPACK S-BAND TV CONVERTER BOARD

Allows reception of microwave TV on ordinary TV sets. Comes with antenna construction plans.
Bare Board and Manual **\$21.00**
Manual Only **\$ 3.95**

ELPACK VHF/UHF AMPLIFIER BOARD

This board uses the popular "CA" package wideband hybrid amplifiers, including such TRW types as CA2800 through CA2880, and others. Large choice of modules to 1000 MHz and 2 watts.
Bare Board and Data **\$10.95**
Data Only **\$ 1.00**

ELPACK MPI DATA SEPARATOR BOARD

Required for OSI minifloppy systems, this data separator plugs into MPI 51/52 drives to provide read data and read clock on separate lines. Improves inner track disk performance.
Bare Board and Data **\$ 6.95**
Assembled Board and Data **\$25.00**

ELCOMP

Publications

Order No.	Price	Title
150	\$11.00	Care and Feeding of The Commodore PET
151	\$ 9.95	8K Microsoft BASIC Reference Manual
152	\$ 9.95	Expansion Handbook for 6502 and 6802 (S-44 Card Manual)
153	\$14.90	Microcomputer Application Notes
154	\$ 6.95	Complex Sound Generation
156	\$14.90	Small Business Programs

REDYSOFT

Software and Firmware for Popular Computers

"MONJANA/1 CBM Monitor ROM" — A well documented, powerful new monitor ROM that any Commodore CBM user can plug into one of the free ROM sockets.

Order Number 2001 **\$98.00**

NEW: Our REDYSOFT Cassette Software

Order No.	Price	Title
3475	\$49.00	Assembler for CBM
3999	\$34.50	BASIC with I/O for TRS-80
8094	\$ 1.10	Blank Cassette (Quantity 1)
8095	\$ 7.99	Blank Cassettes (Quantity 10)
8096	\$69.00	Blank Cassettes (Quantity 100)

Available direct from us NOW. Soon at local dealers. Dealers please contact us for starter stock.

Silver Spur

ELECTRONIC COMMUNICATIONS CO.

USA:

P.O. Box 365
Chino, CA 91710
Tel.: (714) 627-9366

Europe Distributor:
(Request DM-Preis Order Form)
HOFACKER VERLAG
Tegernseerstr. 18
D-8150 Holzkirchen/Obb.
Tel.: 08024/7331

Payment: COD or prepaid

Check, Visa, Mastercharge
POSTPAID IN USA.
California add 6% tax

Cross-Reference for the PET

Jim Butterfield

One of the handy things about the 2040 disk system is that it allows you to read programs - or write them, for that matter - as if they were data files.

The possibilities are endless: you can analyze or cross-reference programs; renumber them; repack them into the minimum number of lines, deleting spaces, comments, etc.; or even create a program-writing program that is tailor-made for a particular job.

This program does cross-referencing of a Basic program. It's written in Basic: that means that it won't run too fast (all those GET statements) but you can read what it's doing fairly easily.

There are two types of cross-references normally needed for a Basic program. One is the variable cross-reference: where do I use B\$? The other is a line number cross-reference: when do I go to line 360? This program does either. An example of both types is shown - the program in this case did the cross-references of itself.

Reading a Basic Program as a File.

To read a Basic program, you must open it as a file, using type P for program. Line 170 of the cross-reference program does this.

If you read a zero character from the program (that's CHR\$(0), not ASCII zero which has a binary value of 48), the GET command gives you a small problem: it will give you a null string instead of the CHR\$(0) you might normally expect. You need to watch for this condition and correct it where necessary: you'll see this type of coding in lines 260, 270 and 300.

The first thing to do when you open the file is to get the first two bytes. These represent the program start address, and should be CHR\$(1) and CHR\$(4) for a normal Basic program starting at hexadecimal 0401. (See line 180).

Now you're ready to start work on a line of Basic. The first two bytes are the forward chain. If they are both zero (null string) we have reached the end of the Basic program; otherwise, we don't need them for this job. (See line 240).

Continuing on the Basic line: the next pair of bytes represent the line number, coded in binary. We're likely to need this, so we calculate it as L (lines 260 to 280) and also create its spring equivalent. L\$. We take an extra moment to right-justify the string by putting spaces at the front so that it will sort into proper numeric order.

From this point on, we are looking at the text of the Basic line until we reach a zero which flags end-of-line. At that time, we go back and grab the next line.

Detailed syntax analysis.

When digging out variables or line numbers, we have several jobs to do. As we look through Basic text, we must find out where the variable or line number starts. For a variable, that's an alphabetic character; for a line number, it's the preceding keyword GOTO, GOSUB, THEN or RUN followed by an ASCII numeric.

Once we've "acquired" the variable or line number, we must pick up its following characters and tack them on. For line numbers, it's strictly numeric digits. For variables, things are more complex. Both alphabetic and numeric digits are allowed, but we should throw away all after the first two, since GRUMP and GROAN are the same variable (GR) in PET Basic. We must also pick up a type identifier - % for integer variables or \$ for strings - if present. Finally, we have to spot the left bracket that tells us we have an array variable.

To help us do this rather complex job, we construct a character type table. Each entry in the table represents an ASCII character, and classifies it according to its type. Numeric characters are type 6. If we're looking for variables, alphabetic characters are type 5, identifiers (% and \$) are type 7, and the left bracket is type 8.

To help us in scanning the Basic line, we define the end-of-line character as type 0; the quotation mark as type 2; the REM token as type 3; and the DATA token as type 4.

Every time we get a new character from Basic, we get its type from table C as variable C9. If we're looking for a new variable or line number, we see if it matches C - alphabetic for variables, numeric for line numbers. Once we find the new item, we kick C out of range and start searching based on the value of C1. This mechanism means that we can search for a variable starting with an alphabetic, and then allow the variable to continue with alphabets, numerics or whatever.

To summarize variables in this area: A is the identity of the character we have obtained from the Basic program, and C9 is its type. If we're searching, C is the type we are looking for; otherwise it's kicked out of range, to -1 or 9. C1 tells us we're collecting characters and what types we're allowed to collect. C2 is our variables/line numbers flag; it tells us what we're looking for. M\$ is the string we've assembled.

The routine from 480 to 520 scans ahead to skip over strings in quotes and DATA and REM statements.

Collecting the results.

For each line of the Basic program we are analyzing, we collect and sort any items we find, eliminating duplicates. They are staged in array A\$ in lines 320 to 370. If they are line numbers, they will be left justified so that the sort will be a little odd - line 100 will come before line 20 since we

use a string comparison.

When we're ready to start a new line, we add this table to our main results table, array X\$, in lines 200 to 220. To save sorting time, we merge these pre-sorted values into the main table. At this point, our data has the line number stuck on the end; this way, we're handling two values within a single array.

Because the merging of the two tables must start at the top so that we can make room for the new items, the items are handled in reverse alphabetic order. We print this to the screen so that you can watch things working. At Basic speed, this program can take quite a while to run; it's nice to confirm that the computer is doing something during this period.

Final Output.

We finish the job starting at line 530. It's mostly a question of breaking the stuck-together strings apart again and then checking to see if we need to start a new line.

Do your own thing.

The size of array X\$ determines how large a program you can handle. The given value of 500 is about right for 16K machines; on 32K you can raise it to 1500 or so.

If you're squeezed for space, change array C to an interger array C%. As you can see from the cross-reference listing, you'll need to change lines 100,140,150,160, and 310 - see how handy the program is?

As mentioned before, run time is slow. A machine language program - or even a Basic program with machine language inserts - would speed things up dramatically.

```

100 DIM A$(15),B$(3),X$(500),C(255)
110 PRINT"CROSS-REF      JIM BUTTERFIELD"
120 Q$=CHR$(34):S$="      ":B$(1)=Q$:
      -B$(3)=CHR$(58)
130 INPUT"VARIABLES OR LINES";Z$:C2=5:
      -IFASC(Z$)=76THENC2=6
140 FORJ=1TO255:C(J)=4:NEXTJ:FORJ=48TO57:
      -C(J)=6:NEXTJ
150 IFC2=5THENFORJ=65TO90:C(J)=5:NEXTJ:
      -FORJ=36TO38:C(J)=7:NEXTJ:C(40)=8
160 C(34)=1:C(143)=2:C(131)=3
170 INPUT"PROGRAM NAME";P$:OPEN1,8,3,"0:
      -"+P$+"",P,R"
180 GET#1,A$,B$:IFASC(B$)<>4THENCLOSE1:
      -STOP
190 IFB=0GOTO240
200 PRINTL$;:K=X:FORJ=BTO1STEP-1:PRINT" ";
      -A$(J);:X$=A$(J)+L$
210 IFX$(K)>=X$THENX$(K+J)=X$(K):K=K-1:
      -GOTO210
220 X$(K+J)=X$:NEXTJ:X=X+B:PRINT:B=0
230 REM: GET NEXT LINE, TEST END
240 GET#1,A$,B$:IFLEN(A$)+LEN(B$)=0GOTO530
250 REM GET LINE NUMBER
260 GET#1,A$:L=LEN(A$):IFL=1THENL=ASC(A$)
270 GET#1,A$:A=LEN(A$):IFA=1THENA=ASC(A$)
280 C=C2:C1=-1:L=A*256+L:L$=STR$(L):
      -IFLEN(L$)<6THENL$=LEFT$(S$,6-LEN(L$)
      -)+L$
290 REM GET BASIC STUFF
300 GET#1,A$:A=LEN(A$):IFA=1THENA=ASC(A$)
310 C9=C(A):IFC9>C1GOTO380
320 K=0:IFB=0GOTO360
330 FORJ=1TOB:IFA$(J)=M$GOTO370
340 IFA$(J)<M$THENNEXTJ:K=B:GOTO360
350 FORK=BTOJSTEP-1:A$(K+1)=A$(K):NEXTK
360 B=B+1:A$(K+1)=M$
370 C=C2:C1=-1:M$=""
380 IFC2=5GOTO420
390 IFA=137ORA=138ORA=141ORA=167THENC=6:
      -GOTO470
400 IFA=44ORA=32GOTO470
410 IFC9<>6THENC=9:GOTO470
420 IFC9=CTHENC=-1:C1=4
430 IFC>6GOTO470
440 IFC<0ANDC9>C1ANDC9>6THENC1=C9:GOTO460
450 IFC2=5THENIFLEN(M$)>2ORC>0GOTO470
460 M$=M$+A$
470 ONC9+1GOTO190,480,480,480:GOTO300
480 B$=B$(C9):C$=""
490 GET#1,A$:IFA$=""GOTO190
500 IFA$=B$GOTO300
510 IFA$=<>Q$GOTO490
520 A$=B$:B$=C$:C$=A$:GOTO490
530 CLOSE1:INPUT"PRINTER";Z$
540 C=3:Z=6:IFASC(Z$)=89THENC=4:Z=12
550 OPEN2,C:PRINT#2:PRINT#2,"CROSS -
      -REFERENCE - PROGRAM ";P$
560 X$="":FORJ=1TOX:A$=X$(J)
570 FORK=1TOLEN(A$):IFMID$(A$,K,1)<>" -
      -"THENNEXTK:STOP
580 B$=LEFT$(A$,K-1):C$=MID$(A$,K+1):
      -IFX$=B$GOTO600
590 PRINT#2:Y=0:X$=B$:PRINT#2,X$;LEFT$(S$,
      -5-LEN(X$));
600 Y=Y+1:IFY<ZGOTO620
610 Y=1:PRINT#2:PRINT#2,S$;
620 PRINT#2,LEFT$(S$,6-LEN(C$));C$;
630 NEXTJ:PRINT#2:CLOSE2

```

softside software 9.95 **PET**



DRIVING ACE

★ ☆ 2 ACTION PACKED VIDEO GAMES ☆ ★

©1979

softside software **PET**

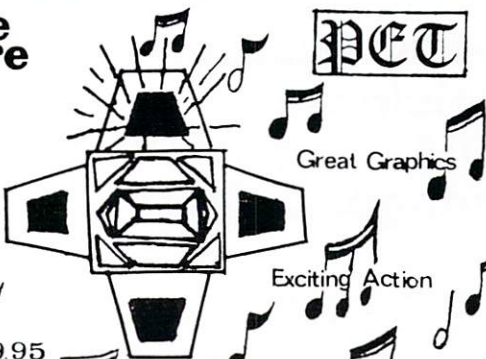

Repeat The Computers Tune as it Grows

Solo or Multi-Player

9.95

Great Graphics

Exciting Action

MUSIC MANIA

ATTENTION! ALL PET OWNERS

Softside Software INC

presents

ASSEMBLY SYSTEM II

Assembly System II is the most **affordable** and most **comprehensive mnemonic assembler** package available for your PET personal computer or CBM professional computer. This package consists of two programs. The Assembler is the most **sophisticated** assembler available in Basic. One program allows the input, editing, saving, recalling, and listing of **standard MOS** machine language programs. A user proof entry system makes mistakes almost impossible. Relative branches are **automatically computed** by the program; minimizing user error. Fast and efficient, this one program does it all. You do **not** have to go through a 3 program process to compile your code. All coding is assem-

bled directly into memory for easy testing and access via the built-in TIM monitor. Code can be executed via both the SYS and USR calls. Operands are accepted in both **decimal and hexadecimal** format. Assembly System II is **compatible** with all 6502 programming manuals and books. The **Disassembler** can unload from memory and directly from tape or disk. A program does not have to be in memory for a complete disassembly to screen or printer. Now you can take a look at those machine language routines that have been hiding from view. Assembly System II is available for **disk or cassette** (specify) based Commodore PET/CBM computers for an introductory price of **\$25.95**. (NEEDS AT LEAST 16K)

ASSEMBLER 2001 FOR 8K PETs STILL AVAILABLE FOR \$15.95

- **AUTOMATICALLY**
- **ANOTHER PET**
- **MOS MNEMONICS**
- **COMPUTES BRANCHES**
- **PROGRAMMING**
- **FULL DISASSEMBLY**
- **FASTEST ASSEMBLER**
- **BREAKTHROUGH**
- **HEX/DECIMAL OPERANDS**

305 RIVERSIDE DRIVE, NEW YORK, NEW YORK 10025

Review

M-100 Microprinter (\$390) Digiclocks 3016 Oceanview Avenue Orange, California 92665

David L. Bosteel
Professor of Architecture
University of Washington
Seattle, WA. 98105

Chuck A. London
Systems Engineer
Boeing Computer Services Company
Seattle, WA. 98124

The M-100 Microprinter is designed for connection to the IEEE-488 port of the Commodore PET, uses 4.75 inch aluminized paper (40 characters/line), and prints approximately 70-150 lines/minute. The unit comes fully assembled in a 10 x 7 x 5 inch high cabinet with built-in interface and power supply. A 22 inch cable is included, and the plugs are easily reversible on the cable so that the printer can be located either to right or left of the PET computer. The unit works with either "old" or "new" ROM's.

The M-100 Microprinter uses a Sharp DC-4002 electro-sensitive printing mechanism with a 8 by 8 dot matrix to print *all* the PET characters and graphic symbols, including cursor control symbols and reverse field printing, as they would appear on the PET monitor for program listings or programmed output. See sample below of printed output and commands. A "Graphics" switch sets (shifted) characters to print graphics symbols as shown on the PET keyboard. A "Line Feed" switch allows one to independently advance the paper one or more lines. The paper is friction-fed and the printer platen is gear driven so that line spacing is fixed at 5 lines/inch with a character height of .115 inches (for lower case or graphics symbols). Thus drawings or

diagrams do not appear exactly as they would on the PET monitor as there is some space between each line.

The M-100 Microprinter very nicely reproduces the PET keyboard symbols, including descenders for lower case letters. The output has more nearly the size and appearance of typed text than is sometimes the case with other printers. The aluminized paper might be seen as a deterrent for record purposes to some, but, for purposes of reproduction, it can be mounted (one or two columns/page) on backing sheets and a xerox copier will provide clean copy without edges or greyness.

The principal uses of a 40 character/line printer are probably to provide listings for development or debugging of programs too long to remember as the lines scroll from the PET monitor screen, and to provide "hard copy" of program output for later use. The PET operating system has commands that make it very easy and these are summarized below as they apply to the M-100 Microprinter. In most cases monitor and printer output are identical but the "TAB" function and use of commas in PRINT# statements for printer output give different (and sometimes unpredicted) results from those seen on the monitor. The use of the "SPC" function and semi-colon separator for same-line printing may be used instead. The use of the semi-colon, when combining a sequence of operations over several lines of a program for same-line printing, appears to confuse the operating system printing firmware, or printer functioning, or maybe only this programmer. Anyhow, the results are different for monitor than for printer. Also, it is inadvisable to leave "open" files lying around in the system--appears to sometimes cause all sorts of puzzling conditions, including a "stuck" cursor (usually recoverable) and unintended programmed input/output formatting.

It is useful, in any case, to organize printer output separately from that for monitor. The PET monitor has the annoying characteristic of flashing (goes dark, then screen image returns) as each print line is output to printer. Much better practice is to organize hard copy output in a subroutine that first

SOFTWARE SPECIALISTS

MICROPHYS PROGRAMS

SCIENCE AND EDUCATION

2048 FORD STREET
BROOKLYN, NEW YORK 11229
(212) 646-0140

M_p

Dear Educator:

Microphys has released two utility programs which have been designed to permit instructors in every academic area to establish an unlimited number of source files in which questions used on exams and homework assignments may be conveniently stored. These questions may then be accessed by students as a means of review and may also serve as the basis for individualized exams and homework assignments.

QUESLO enables the instructor to readily create source files. The text of each question is merely typed into the computer and stored on the disk file designated by the instructor. Additional questions may be added to a given file at any time.

QUEGEN can access any source file and generate an individualized exam or assignment for each student using a subset or the entire group of questions previously entered. QUEGEN will either provide the correct answers so that a student may assess his performance or QUEGEN will request the student to enter his answers into the computer. QUEGEN will then grade the assignment, displaying the correct answers to those questions missed. A percent score is indicated and a brief comment, reflecting an overall evaluation, is also given.

QUESLO and QUEGEN have been designed for exclusive use on the Commodore 16/32K PET microcomputer. The 2040 dual disk drive peripheral is also required. The two programs are accompanied by complete instructions and sell as a set for \$40. Source files containing questions in virtually every academic discipline will soon be made available.

The programs are obtainable from your local computer dealers or, if unavailable, they may be purchased directly from Microphys.

NOTE: A free, educational software catalogue is available upon request from Microphys. This catalogue describes over 140 programs currently available.

clears the screen of previous messages, then outputs new information to printer, and subsequently prints the same messages/information to monitor screen. The result is a stable image which minimizes the impact of printer output on monitor screen.

A brief note on hardware. The unit is attractively housed, solidly constructed, and appears to use good quality components. We say "appears" as the manufacturer recommends very careful disassembly (necessary to expose logic board and electronic components) so as not to tear the ribbon cable linking the printer base and the printing head. As a number of PET owners may be electronic buffs and could test/replace components, it might be better if the board were more readily accessible. We decided a working printer was preferable to a more complete inspection and can only note that electronic components are soldered, not socketed. The stated nominal life for the printer mechanism (40 million characters MTBF; 1 million strokes minimum, 3 million usual) is reassuring given present usage of one roll of paper per month (130 feet = 7500 lines or approximately 200,000 characters).

The M-100 Microprinter arrived promptly (4 days) via UPS, was easily connected, and worked immediately. Some two rolls of paper later (\$6/roll, Radio Shack) it continues to work. That brief period of six weeks is not a fair test of longevity, or even the warranty, but it is long enough to explore potential capabilities and to learn to use the printer effectively in programming. The Digiclocks unit was purchased because it was/is the most inexpensive printer available that provides all the PET characters and graphic symbols. When the principal uses will be program listings and programmed hard copy, the Digiclocks printer would appear to be an excellent choice. For extensive text processing it is a personal view that only IBM Selectric or Daisywheel type output is satisfactory and those alternatives are beyond present means. While the M-100 Microprinter lacks some of the programmable features of the "intelligent" Commodore printer, the PET operating system makes it easy to obtain formatted printer output for most uses.

M-100 Microprinter

```

OPEN6,5:CMD6
listing- LIST
PRINT# - PRINT#6,'ANYTHING'
CLOSE6
program output- 10 OPEN6,5:CMD6
                20 PRINT#6,'ANYTHING'
                30 CLOSE6
GRAPHICS (OFF)= lower case(if 'SHIFT'ed)
              (ON) = graphics symbol
ABCDEFGHIJKLMN OPQRSTUVWXYZ /#%&? \
abcdefghijklmnopqrstuvwxy z
⊕|—| | k v l v m n o p q r s t u v w x y z
1234567890123456789012345678901234567890
    
```

GREAT PET SOFTWARE!



"Precise, humanized, well documented an excellent value" are the applauds now being given to United Software's line of software. These are sophisticated programs designed to meet the most stringent needs of individuals and business professionals. Every package is fully documented and includes easy to understand operator instructions.

KRAM - Keyed Random Access Method - The new, ultra-fast access method for the PET Disk, provides keyed retrieval/storage of data, in either direct or sequential mode, by either full or partial key values. Written by United Software in 6502 machine code, and designed with the PET in mind, it exploits all the benefits of the PET Disk, allowing full optimization of your system. Eliminates the need for "Sort" routines! KRAM provides flexibility never seen on a micro before. KRAM is modeled after a very powerful access method used on large-scale IBM Virtual Storage mainframes. So "KRAM" all you can into your PET - it will love you for it. ... **COST \$79.95**

ACCOUNTS RECEIVABLE/PAYABLE - A complete, yet simple to use accounting system designed with the small businessman in mind. The United Software system generates and tracks purchase orders and invoices all the way through posting "controlled" accounts payable and accounts receivable subsystems. Keyed Random Access file methods makes data access almost instantaneous. The low-cost solution for the first time computer user with up to 500 active accounts. Requirements - 32K PET, Dual Disk, any 80-column printer. ... **COST \$175**

CASH RECEIPTS & DISBURSEMENTS - Makes it a breeze to track all outgoing payments made by any type of business operation. Checks are tracked by number and categorized by type of expense. Sorting, summary, and audit trails make it easy to post to general ledger. This system also categorizes incoming receipts. Uses KRAM file access method. Requirements - 32K PET, Dual Disk (printer optional). ... **COST \$99.95**

DATABASE MANAGEMENT SYSTEM - A comprehensive, interactive system like those run on mainframes! Six modules comprising 42K of programming allow you to: create, edit, delete, display, print, sort, merge, etc., etc. - databases of up to 10,000 records. Printer routines automatically generate reports and labels on demand. 60 pages of concise documentation are included. Requirements - 16-32K PET and 2040 Dual Disk (printer optional). ... **COST \$125**
(Sublicenses available to software houses.)

PROGRAMS FOR ENTERTAINMENT	Super Startrek 14.95
Space Intruders	PET Music Box 29.95
("Best Game of 1979") .. \$19.95	UNITED SOFTWARE PROGRAMS FOR BUSINESS
Jury/Hostage 12.50	Checkbook \$15.95
Kentucky Derby/Roulette 9.95	Mortgage 15.95
Alien I.Q./Tank 9.95	Finance 12.95
Tunnelvision/Maze Chase 14.95	Bonds 12.95
Submarine Attack 9.95	Stock Analyzer 22.95
Battle of Midway 7.95	Stock Options 24.95
Laser Tank Battle 9.95	6502 Macro Assembler ... 49.95
Swarm 14.95	

Look for the RED-WHITE-BLUE United Software Display at your local computer dealer, or send check or moneyorder, plus \$1.00 shipping to:

UNITED SOFTWARE OF AMERICA
750 Third Ave. **DEALER ORDERS INVITED**
New York, N.Y. 10017 **(212) 682-0347**

Microphys Programs

Dear Educator:

Microphys is pleased to introduce its series of computer programs which have been specifically designed for use on the Commodore 8K PET and 1632K CBM microcomputers. These programs have readily enabled instructors to provide their students with an opportunity to review, in an interesting and effective manner, the important concepts encountered in introductory courses in chemistry, physics, mathematics, vocabulary, and spelling.

Please note that the vast array of software programs, which have been **uniquely** designed for use on the PET microcomputer, will readily enable you to use the microsystem in your courses as soon as it arrives. The programs are available on cassette tapes and arrive complete with full instructions for their immediate use even by those who have little, if any, experience with the use of the computer itself.

There are three types of programs in the Microphys series:

- I. **Computer-Assisted Instruction Programs** guide the student through a series of quantitative questions; the student interacts with the computer and receives immediate evaluation of his responses and/or assistance when needed. Each time a particular program is run, a different set of numerical data is generated. In most instances, an entirely new problem is presented.
- II. **Individualized-Instruction Programs** generate a unique set of problems for each student. The essential information needed to solve each problem is recorded and, when he is ready to do so, the student may obtain the computer's answers and compare his results. These answers may be suppressed by deleting line number 8500 in any program. When now run, a unique set of problems is produced for each student who records the essential information along with his code number which is generated by the computer. When his work is completed, the student enters his code number and answers into the program which had given him his assignment. The computer will then grade his work, displaying the answers to those problems which were

incorrectly solved; a percent score and a brief comment reflecting an overall evaluation are also given.

- III. **Utility Programs** are designed to provide solutions to time consuming problems often given on exams or homework assignments. Problems in calorimetry, stoichiometry, projective motion, vector analysis, etc. require tedious computation. These utility programs free teachers from the time required to obtain the correct solutions. Students may also be permitted access to these programs in order to check their own work.

Please note that each physics and chemistry program has both the computer-assisted instruction and individualized instruction versions recorded on opposite sides of the cassette. The vocabulary programs are similarly designed; the computer assistance being rendered by providing the student with a sentence in which the word to be defined is used properly. With this contextual clue, the student is again asked to correctly select the proper definition. The math cassettes have only an individualized-instruction mode.

Microphys has released its educational software on floppy diskettes designed for use on the Commodore 2040 dual drive floppy disk unit. Each diskette is accompanied by complete instructions for those programs recorded upon it. Write for details.

Microphys programs are available from local computer dealers. If your dealer does not carry the programs, you should encourage him to contact Microphys directly, or the Microphys distributor serving the geographic area. You may of course order software directly from Microphys if programs are not obtainable locally.

An educational software catalogue, describing the nature of the various programs listed below, is available from Microphys.

Note: Please indicate whether you desire the 8K or 16K version of a given program when placing an order.

The cost of each cassette is \$20.

Chemistry and Physics Cassettes

1. Linear Kinematics
2. Projectile Motion*
3. Momentum and Energy*
4. Energy and the Inclined Plane
5. Inelastic Collisions
6. Centripetal Force
7. Pulley Systems — Machines*
8. Specific Heat Capacity
9. Calorimetry
10. Heats of Fusion/Vaporization
11. Specific Gas Laws
12. General Gas Law
13. Thermodynamics I
14. Thermodynamics II
15. Transverse Standing Waves
16. Longitudinal Standing Waves
17. Lenses and Mirrors*
18. Refraction of Light
19. Series Circuit Analysis
20. Parallel Circuit Analysis I
- 20A. Parallel Circuit Analysis II
21. Series/Parallel Circuit Analysis*
22. Faraday's Law
23. Gram-Molecular Mass
24. The Mole Concept*
25. The Molarity Concept*
26. The Normality Concept
27. The Molality Concept
28. Stoichiometry: Mass/Mass
29. Stoichiometry: Mass/Volume
30. Stoichiometry: Volume/Volume
31. Stoichiometry: General*
32. Percent Concentration
33. pH Concept
34. EMF of Electrochemical Cells
35. Electric Field Analysis
36. Photoelectric Effect
37. Symbols and Valence Drill
38. Formulas of Compounds Drill*
40. Total Internal Reflection

DEALER INQUIRIES INVITED

Vocabulary Cassettes

401. 12th Grade I
402. 12th Grade II
403. 12th Grade III
404. 12th Grade IV
405. 12th Grade V
406. 11th Grade I
407. 11th Grade II
408. 11th Grade III
409. 11th Grade IV
410. 11th Grade V
411. 10th Grade I
412. 10th Grade II
413. 10th Grade III
414. 10th Grade IV
415. 10th Grade V
416. 9th Grade I
417. 9th Grade II
418. 9th Grade III
419. 9th Grade IV
420. 9th Grade V
421. 8th Grade I
422. 8th Grade II
423. 8th Grade III
424. 8th Grade IV
425. 8th Grade V
426. 7th Grade I
427. 7th Grade II
428. 7th Grade III
429. 7th Grade IV
430. 7th Grade V

Spelling Cassettes

601. Spelling I Grade 12
602. Spelling II Grade 12
606. Spelling I Grade 11
607. Spelling II Grade 11
611. Spelling I Grade 10
612. Spelling II Grade 10

Math Cassettes Senior High School

701. Quadratic Equations
702. Trigonometry I
703. Simultaneous Equations (2x2)
704. Simultaneous Equations (3x3)
705. Geometrical Areas
706. Trigonometry II
707. Verbal Problems I — Numbers
708. Verbal Problems II — Coins
709. Verbal Problems III — Ages
710. Verbal Problems IV — Interest
711. Verbal Problems V — Mixtures
712. Verbal Problems VI — Geometry
713. Verbal Problems VII — Rates
714. Verbal Problems VIII — Digits
715. Verbal Problems IX — Work
716. Arithmetic Progressions I
717. Arithmetic Progressions II
718. Geometric Progressions I
719. Geometric Progressions II
720. Types of Variation
721. Linear Equations
722. Formula Evaluation
723. Coordinate Geometry I
724. Exponents and Logarithms
725. Verbal Problems — General

Math Cassettes Junior High School

801. Magic Squares
802. Multiplication
803. Division
804. Modular Arithmetic
805. Proportion Problems
806. Percent Problems
807. Addition of Fractions
808. Subtraction of Fractions
809. Multiplication of Fractions
810. Division of Fractions
811. Mode, Median, and Mean
812. Bar Graph Analysis
813. Decimals I
814. Decimals II
815. Verbal Problems I

Utility Cassettes

301. Vector Analysis I
302. Vector Analysis II
303. Gas Law Analysis
304. Optics Analysis
305. Projectile Analysis
306. Calorimetry Analysis
307. Chemistry I Analysis
308. Chemistry II Analysis
309. Stoichiometry Analysis

NEW 350. Cryptogram Generator/Decoder

Microphys Programs
2048 Ford Street
Brooklyn, New York 11229
(212) 646-0140

In this issue, Marlene Pratto continues her presentation of the grading program shown in Issue 3's column. This time tape and disk data storage options are added. RCL

The Learning Lab

Marlene Pratto

This grading program originated on a 32K PET without a printer. Its major idea was to maintain the information in the machine in arrays for easy reviewing and recording of the results by hand. Options are now provided for storing and retrieving the partial or full term data on tape or disk (tape refers to cassette tape I/O and disk refers to the CBM 2040 disk drive I/O, while I/O refers to input/output operations).

The user is asked how the data will be entered (statements 2905-2907) and there is a new item in the menu (statements 27620-27640) allowing the data to be saved. Of the numeric data, only the raw student grades are stored. When the data is read from tape or disk the user may choose to add grades if the total number of grades will not exceed the maximum in 2150. The averages, z scores, and frequencies are then recalculated and the menu presented.

As the average are calculated, the user is asked the average is "okay". If a change is needed and the input came from tape or disk, all of the current scores are printed to refresh the user's memory (statements 13200-13560). If the user wants to review the grades, he/she may ask to change one grade and merely input the same value. Note that a change of input method was made here in order to speed up the program (13250). If you prefer using the return key, do not make this change.

The instructions concerning grade changes have been modified. For each student the user may change all grades or one grade at a time (13600-14000).

Since the scores may come from more than one input source, two variables are needed to keep track of the number of grades from each. A new variable NN is used for the number of grades entered initially and NP is the number of grades added on a subsequent run. In the first case $N = NN$ and in the second case $N = NN + NP$.

Writing the Data File

Observe statements 36010-36097. RV is a variable which points to where the program should continue if there is an I/O problem and IT refers to disk or tape. The filename and an indicator for tape or the disk drive number are requested.

The form of the OPEN statement is *OPEN parm1, parm2, parm3, parm4* where parm1 is the logical file number, parm 2 is the device number (DV), parm3 is the secondary address (SA), and parm4 is the filename and/or commands. The variables, DV and SA, are assigned differently for tape or disk (36024 & 36028). The disk filename is modified as

shown in 36028. The fourth parameter consists of the drive number (either 0 or 1) followed by a : (colon), the name provided by the user and finally indicators for SEQuential file type and WRITE mode of operation.

In addition, for disk I/O, we OPEN the com-error channel in order to check for disk errors. We *choose* to use file number 2 and we *must* use Secondary Address 15. Some form of initialization of the disk drive must occur. It is included in the OPEN command by using "I" + H\$ as the fourth parameter where H\$ is the disk drive number provided by the user. (We are assuming that the diskette has been formatted at this point.)

Tape file writing is indicated by a Secondary Address of 1. Disk file writing is indicated by file type (SEQ) and mode (WRITE) which are part of the fourth parameter in the OPEN statement. In either case, the first parameter is the file number which will later appear after the # in the PRINT# statements.

IT is checked in 36032. If the user has not responded with T or 0 or 1, the program returns to 36022 to elicit the proper response.

Information is written to the external medium in the following order: 1) file identifier (32 characters or less of information), 2) number of students, 3) number of grades per student, and 4) a character (D\$) to indicate whether identifiers have been provided by the user or if sequence numbers will be written as identifiers.

For each student an identifier or sequence number and the student's grades are written. After the last(Jth) student's data, DONE is written. The user is informed when the file writing is completed and is returned to the menu.

Reading the Data File

The program asks how data is to be read (2905-2907). If the data comes from tape or disk, the filename is entered (2925), and the DeVice number and Secondary Address are set (2930-2935).

Tape file reading is indicated by a Secondary Address of 0. For disk, the fourth parameter is similar to that for writing, except that the mode is replaced by READ. The error channel is opened and the disk drive is initialized (this may occur twice in the program since the read and write portions are independent of each other and the user may choose any of several combinations of I/O options.) File 1 is opened for either disk or tape reading. Student data are read in 10250 and 11560.

Data as Character Strings

The data are written as character strings. On input the data are read as character strings and converted to numeric data as needed. Microsoft BASIC provides two functions for converting data from numeric to character and character to numeric. STR\$(numeric variable) will convert a number to a string, while VAL(string variable) will convert a string to a number.

If the string variable does not consist of numerals, VAL returns a value of 0.

ERROR TESTING

Disk errors are checked in the subroutine at 36610 and tape errors in the subroutine at 36710. It is not possible to make the program super smart concerning error recovery, but an attempt is made rather than simply stopping the program.

Please make the following correction to the listing. 36095 CLOSE 1: IF DV = 8 THEN CLOSE 2

REFERENCES

Commodore Business Machines, *CBM Users Manual*, 1979

Commodore Business Machines, *CBM Floppy Disk User Manual*, 1979

Total Information Services, *TIS Workbook 4*, 1978

```

1450 REM K$ FILE IDENTIFIER
1470 REM E$ ERROR CHANNEL MESSAGES
1500 REM J NUMBER OF STUDENTS
1600 REM NN NUMBER OF GRADES PER
1700 REM STUDENT INITIALLY, NP GRADES
1710 REM ADDED, N=NN+NP
1720 REM MN=MAXIMUM # OF STUDENTS
1730 REM MG=MAXIMUM # OF GRADES PER -
      -STUDENT
1740 REM RV RETURN TO INPUT OR OUTPUT
1750 REM IT=1 FOR DISK, IT=2 FOR TAPE

2100 DIM N$(50), E$(4), Z(50)

2100 DIM N$(50), E$(4), Z(50)
2150 MN=50 :MG=10 :RV=1
2200 PRINT"[CLR]"
2300 PRINT"THIS PROGRAM ASSUMES THAT ";
2400 PRINT"YOU DO NOT HAVE MORE THAN ";
2500 PRINT"50 STUDENTS AND 10 ";
2600 PRINT"GRADES PER STUDENT. IF ";
2700 PRINT"YOU DO, CHANGE THE DIM ";
2800 PRINT"STATEMENTS AND 2150."
2900 PRINT
2905 PRINT"INDICATE ENTRY OF DATA BY -
      -K$ KEYBOARD, R$ TAPE, DRIVE R$ "
2907 PRINT" OR DRIVE R$. "
2910 INPUT M$:M$=LEFT$(M$,1)
2920 IF M$="K" THEN DV=0:NP=0:GOTO 3000
2925 INPUT"ENTER FILENAME ";F$
2930 IF M$="T" THEN DV=1:SA=0:IT=2:
      -GOTO2950
2935 IF M$="0" OR M$="1" THEN DV=8:SA=5:
      -IT=1: F$=M$+"":+F$+", SEQ, READ"
2937 IF IT=1 THEN OPEN 2, DV, 15, "I"+M$:
      -GOSUB 36610:GOTO 2950
2940 PRINT"ENTER K, T, 0, OR 1.":GOTO 2910
2950 OPEN 1, DV, SA, F$:IF IT=1 THEN GOSUB -
      -36610
2952 INPUT#1, K$:ON IT GOSUB 36610, 36710
2954 PRINT"FILE IDENTIFIER IS ";K$
2956 INPUT#1, H$:ON IT GOSUB 36610, 36710
2958 JT=VAL(H$):IF JT=0 THEN PRINT"# OF -
      -STUDENTS IS 0":GOTO 2905
2960 INPUT#1, H$: ON IT GOSUB 36610, 36710
2962 NN=VAL(H$):IF NN=0 THEN PRINT"# OF -
      -GRADES IS 0":GOTO 2905
2964 INPUT#1, D$: ON IT GOSUB 36610,
      -36710:D$=LEFT$(D$,1)

```

```

2975 PRINT"NUMBER OF STUDENTS IS ";JT
2980 PRINT"NUMBER OF GRADES IS ";NN
2985 IF D$="Y" THEN PRINT"THESE ARE -
      -IDENTIFIERS."
2990 IF N<MG THEN INPUT"HOW MANY GRADES -
      -WILL YOU BE ADDING ";NP
2995 IF NN+NP >MG THEN PRINT"TOO MANY":
      -GOTO 2990
2999 N=NN+NP

4550 IF DV>0 THEN 6200

10200 IF D$="N" AND DV=0 THEN 10700
10250 IF DV>0 THEN INPUT#1, N$(J+1):
      -ONITGOSUB36610, 36710:PRINTN$(J+1):
      -GOTO10500

11300 IF DV=0 THEN PRINT"ENTER";N;
      -"GRADES FOR ";
11350 IF DV>0 THEN PRINT "ENTER";NP;
      -" GRADES FOR ";
11400 PRINT"STUDENT ";J
11500 FOR I=1TON
11520 IF DV=0 THEN 11600
11540 IF I>NN THEN 11600
11560 INPUT#1, H$:ON IT GOSUB36610, 36710
11580 STUDENT(J, I)=VAL(H$):GOTO11800
11600 PRINT "GRADE #";I;

13200 PRINT"OKAY?";
13250 GET C$:IF C$="" THEN 13250
13400 PRINT C$
13500 IF C$="Y" THEN 10200
13530 IF DV=0 THEN 13600
13540 PRINT"CURRENT GRADES:"
13550 FOR P=1TON:PRINT STUDENT(J, P);
13560 NEXT P:PRINT
13600 PRINT"WHICH GRADE (IF MORE THAN ";
13700 PRINT"ONE GRADE NEEDS CHANGING, ";
13800 PRINT"YOU MAY CHANGE ONE AT ";
13900 PRINT"A TIME OR CHANGE ALL BY ";
14000 PRINT"ENTERING ";

16699 REM IF OPEN FILES, THEN CLOSE
16700 IF DV=1 THEN CLOSE 1
16710 IF DV=8 THEN CLOSE 1:CLOSE 2
16720 PRINT:PRINT"WHEN YOU ARE READY ";

23200 IF Q<10 OR C$="N" THEN GOTO 23700

27620 PRINT CHR$(18);"7";CHR$(146);
27640 PRINT"WRITE FILE"

36010 REM WRITE FILE OF PERTINENT INFO
36012 REM AND RAW STUDENT GRADES
36020 RV=2:IT=0
36021 INPUT"FILENAME_";F$
36022 INPUT"R$ TAPE OR THE DRIVE NUMBER -
      -FOR DISK ";H$:H$=LEFT$(H$,1)
36024 IF H$="T" THEN IT=2:DV=1:SA=1:
      -GOTO36050
36028 IF H$="0" OR H$="1" THEN IT=1:
      -DV=8:SA=6:F$=H$+"":+F$+", SEQ,
      -WRITE"
36030 IF IT=1 THEN OPEN 2, DV, 15, "I"+H$:
      -GOSUB 36610
36032 IF IT=0 THEN 36022
36050 OPEN 1, DV, SA, F$:IF IT=1 THEN -
      -GOSUB 36610

```



```

36054 INPUT"ENTER AN IDENTIFIER FOR →
      →THIS SET OF STUDENTS ";H$
36058 PRINT#1,H$:IF IT=1THEN GOSUB 36610
36062 H$=STR$(J):PRINT#1,H$:IF IT=1 →
      →THEN GOSUB 36610
36066 H$=STR$(N):PRINT#1,H$:IF IT=1 →
      →THEN GOSUB 36610
36070 PRINT#1,D$:IF IT=1 THEN GOSUB36610
36080 FOR H=1TOJ
36081 IF D$="Y" THEN PRINT#1,N$(H):
      → GOTO 36084
36082 REM ELSE PRINT SEQUENCE #
36083 PRINT#1,STR$(H)
36084 IF IT=1THEN GOSUB 36610
36086 FOR L=1 TO N
36088 H$=STR$(STUDENT(H,L)):PRINT#1,H$
36089 IF IT=1 THEN GOSUB 36610
36090 NEXT L: NEXT H
36092 PRINT#1,"DONE":IF IT=1 THEN GOSUB →
      →36610
36095 CLOSE 1:IF IT=2 THEN CLOSE 2
36097 PRINT"FILE WRITTEN. RETURN TO →
      →MENU.": RETURN
36610 REM ERROR CHECKING ROUTINE FOR →
      →DISK IO
36620 INPUT#2,E$(1),E$(2),E$(3),E$(4):
      →IF E$(1)="00" THEN RETURN
36630 REM ELSE THERE IS AN ERROR
36640 FOR P=1TO4: PRINT E$(P): NEXT P
36650 PRINT"CORRECT THE ERROR, IF →
      →POSSIBLE. TO CONTINUE THE PROGRAM"
36660 PRINT"PRESS ANY KEY.":CLOSE 1:
      →CLOSE 2
36670 GET Y$: IF Y$="" THEN 36670
36680 ON RV GOTO 2905, 36020
36690 RETURN
36700 REM ERROR ROUTINE FOR TAPE
36710 IF ST=0 THEN RETURN
36720 IF ST<64 THEN PRINT"STATUS IS ";
      →ST;". TRY AGAIN.":GOTO 37740
36730 IF ST=64 THEN PRINT"EOF ON TAPE."
36740 PRINT"PRESS ANY KEY TO CONTINUE."
36750 GET H$:IF H$=""THEN 36750
36760 RETURN

```

©

Hard Working Software for PET/CBM™ Micros

MATRIC™

MATRIC expands Commodore BASIC with fourteen new commands for handling arrays.

Display a matrix on the screen and change its values. Transfer data between matrices or fill a matrix with a constant. Transpose. Transfer diagonals between matrices, or from a matrix to a vector, or from a vector to a matrix, or fill a diagonal with a constant. Do vector or matrix addition, subtraction, multiplication; elementwise multiplication, division, squares, and square roots. Inversion. Determinant. Eigenvalues and eigenvectors of a square, symmetric matrix.

Algebraic style syntax, checks for conformability, extended error messages.

The 5K machine language program comes on tape or disk with a 32-page manual. Specify size and ROM set of your machine. Price: \$125.

PRO-GRESS™

This multiple regression program reads data from tapes or CBM disk. Concatenates files. Selects records. Deletes cases with missing data. Transforms variables. Generates new variables. Allows keyboard input of means, standard deviations, correlations. Names variables.

Provides means, standard deviations, correlations; R, R-square, F, degrees of freedom; constant and coefficients, betas, Student's t's. Output to screen, or to ASCII or CBM printer.

Analyzes 10 predictors in 8K; 25 in 16K; 45 in 32K. No limit on number of records. Approximate timing: ¼ minute per 100 records with one predictor; 30 minutes per 100 records with 45 predictors.

You get two programs and a manual. Program I has elaborated instructions, requires 16K or 32K. Program II has abbreviated instructions, runs in 8K or more. Cassette tape: \$45. Disk: \$50.

TEXTCAST II™

A word processor for 8K and larger machines, old or new ROMs. All in machine language.

Edit with tapes or disks in any combination. Produces ASCII files that can be used by other programs.

Unfinished words at the end of a line leap to the next line while you type. Powerful screen editor with full control over visible cursor. Repeat action on all keys and commands.

Use printer in typewriter mode. Prints files with centering (enhance on PET printer), underlining (reverse on PET printer), right justification, page numbers at top or bottom. Set left margin and line length. Transmits all NEC Spinwriter[®] characters and commands.

You get old and new ROM versions of the program, and revised manual. On tape: \$75; on diskette, \$80.

Order your WorkerWare from:

COGNITIVE PRODUCTS,[®] P.O. Box 2592, Chapel Hill, NC 27514

STRUCTURED GAMING: Play and Work in High School Computer Science

J. M. Moshell, G. W. Amann (The University of Tennessee)

W. E. Baird (West High School) Knoxville, Tennessee

Excerpted with permission from a paper to be presented at the National Educational Computing Conference in Norfolk, VA., June 23-25. © Copyright 1980, University of Iowa. All Rights Reserved.

Prologue:

Question 1: When is a computer game not a game? When is it "ok" class-activity?

Question 2: So what's wrong with games, anyway?

Exasperated answer to 2:

Students won't work on programs when they have access to games. Games are fun and programs are work.

Reflective answer to 2:

The "usual" computer games are either hand-eye (with occasionally some small amount of brain) - coordination contests, such as "Lunar Lander", or fantasy-land interactive do-it-yourself storybooks such as "Dungeons and Dragons". These activities partake of the allure of broadcast television: namely, they involve the student kinetically and emotionally, but they do not have a "cumulative" component. You can walk in on television, (or computer games like PONG or SPACE WAR) anytime; there are no prerequisites, no logical-deductive skills are required. (For an excellent exploration of this theme, see (Postman, 1979).)

We cannot call this kind of attention "passive" - observe any kid watching an action TV show, or playing a video game. Nevertheless the interaction is "non-analytical" - it has more in common with baseball than with reading; more of recess to it than of curriculum. No wonder teachers of computing have "game trouble" whenever interactive terminals or mini-micros become available.

The problem this paper explores is the development of an introductory computing curriculum built around a kind of "structured gaming". The computing community has begun to understand that carefully-chosen programming language features can guide our thought in ways that make code "work across time": remain adaptable, comprehensible, repairable. We propose that a similar choice of **gaming**-features can foster the development of logical problem-solving skills, while retaining the kinetic/esthetic motivational structure of video games. (We have all known "programming hacks" who have made the game/program connection.) We want to use microcomputer color graphics to make computing more like color-crayons, and less like arithmetic.

Having said that much, we will answer Question 1, and then flesh out our answer with a description of the curriculum we are developing, based on our answer.

Question 1: When is a "computer game" an "ok" class activity?

Answer:

- 1) The game must be designed with a set of concepts and skills in mind, and a plan for how the games teaches them;
- 2) The things learned in the activity must contribute toward a cumulative body of knowledge, a "toolkit" that the student can perceive and make use of, as toys and toy-making tools; and
- 3) The game must be superceded by a more interesting, more interactive game, chosen with extreme care to be unplayable unless the student has mastered the skills taught in the previous lesson/game.

Challenge:

Our basic mission, in the University of Tennessee/NSF High School Computer Science Curriculum Project (HSCS), is to make computer skills available to "average" students. Computers may indeed become as ubiquitous as telephones and televisions, and we consider that the introduction of another technology as soporific and captivating and, well, anti-thinking as television could be a major social disaster. We hope, rather, that computers will become "convivial tools" like the telephone; "convivial" means that their use is determined by the user, not by some central least-common-denominator such as a broadcaster. We haven't really got utopian ideas as to what future generations will do with computers (who could have predicted in 1915 what we'd do with automobiles?). We do, however, have a strong feeling that the question of whether individuals will be able to program their computers, or merely buy programs, is an open and important question. The challenge is this, then: to give every citizen who can dial the telephone, some ability to program a computer.

Method:

This section will be brief; we have published elsewhere (Aiken, Hughes, Moshell, 1980) the "nuts and bolts" description of HSCS. We are using a cartoon-animation software system called RASCAL (Moshell & Hughes, 1980), which runs as part of UCSD PASCAL on the APPLE microcomputer. The basic installation costs about \$3200, including a single floppy disk, color television and 100 character-per-second printer. Each lesson in a one-semester (eighteen week) course consists of approximately a week of work, divided into these parts:

- Introductory activities;
- Exploration project;
- Skill-building projects;
- Buttoning-up activities;

A class consists of about fifteen students per computer (our collaborating schools have only one APPLE each; we hope to try the curriculum in multi-computer classes later.) Five groups of three students alternate computer use with planning work using graph paper and marker pens. The off-line students are planning their strategies, doing hand-simulations, and observing the online students; for to graduate to the next activity, a group must successfully predict the outcome of an assigned "seed" (geometric pattern, algorithm, program, etc.) The activities develop during eighteen weeks, from a non-linguistic color-pattern process called "quilting" through immediate-mode and straight-line-code entry of TURTLEGRAPHICS (Papert, 1970) commands, the introduction of PASCAL control structures such as REPEAT. . . UNTIL and IF. . . THEN, to the creation of cartoon characters and their animation with complex programs using the RASCAL animation system. The output is always color graphics and music; the curriculum steadily increases its "interactivity" as students learn how to use joystick input to control various types of motion. There is always an underlying lesson about how programs work. All code is in a completely structured language (PASCAL), and is taught "from the inside out" - only at later stages do "environmental details" such as declarations become of concern. A PASCAL interpreter is used which scrolls the source-program being executed on the bottom of the screen (at a controllable rate) while the program produces its output on the top part of the screen. A working system will be on exhibit at NECC/80.

The cognitive style of the HSCS Curriculum

The central common fact that unifies our program/lessons Quilting, Turtlegraphics and more traditional interactive games is that they sell themselves. No one has to compel students to do their assignments.

The point at which our curriculum diverges from "closed" games is in the fact that the only real opponent in traditional games is a pseudo-random number generator, or perhaps another human. In a cognitive game the opponent is the rich structure of our own ignorance. . . The excitement of being able to create pattern and order is as old as the wall-paintings in the caves of France. It is an essentially human activity, one at which all players can win. It is also a 'meta-game', in which an infinite number of specific games and traditional games is analogous to that between a set of blocks and a preassembled toy. A different order of learning becomes possible.

The design style of the HSCS Curriculum

The fundamental design principle we have followed is to attempt to make each lesson augment the student's skills in three areas: discovery, control, and design. We allow students to "play" with the system as each new feature is introduced, but they have "discovery questions" whose answers

they seek as they "mess around", in more or less structured ways. They need to find the answers to be allowed access to the next level of the system. Students develop discovery skills by experimentally answering questions like "what does this command do?"

We ask students to undertake a specific "challenge", such as the "shoot-the-dot" game, to develop their ability to control the computer by selecting the correct command and providing correct values for its operands. Their understanding of the system is built by simulation exercises, which allow them to predict the behavior of a command, thus to choose the right command.

Later in the semester, students will begin writing programs; but even at early stages there is the impetus to design input sequences to produce the desired pattern. Students must be able to produce a sequence of commands which produces the predicted output on first submission, to graduate to the next level of the system.

Another principle we have followed can be summed up in the phrase "design from the first experience". We believe that computer science (or anything else) should be taught "from the inside out". That is, first experiences must incorporate the heart of the matter at hand, with as little extraneous matter as possible. For instance, quilting teaches the fundamental core of the computing experience: in repetition of a controlled process, there is great power. The Quilting lesson is taught without introducing a word of jargon, previous assignments, or complex command sequences. Quilting, and its fundamental message, can be taught to illiterates. The second lesson similarly teaches the relationship between operands, operators and results. Only after students have firm operational skill with a given tool, do we introduce terminology, written reference materials and the ultimately necessary environmental details such as data declarations and control statements. We are excited by the prospect of transforming gaming, a traditional problem area for computing teachers, into one of their primary tools.

The authors acknowledge and appreciate the assistance of their collaborators: R. M. Aiken, C. E. Hughes, C. R. Gregory and J. A. Ross (University of Tennessee); L. Demarotta (H. C. Maynard High School); E. Miner (Alcoa High School).

References

- Aiken, R. M.; Hughes, C. E.; and Moshell, J. M., "Computer Science Curriculum For High School Students", Proceedings ACM/SIGCSE Conference, Kansas City, Montana, February 25, 1980
- Moshell, J. M. and Hughes, C. E. "RASCAL: Microcomputer cartoon animation with PASCAL", Proceedings ACM/SIGGRAPH Conference, Seattle, Washington, August 1980
- Papert, S., "Teaching Children Thinking", Proceedings IFIP World Congress on Computers and Education, Amsterdam, 1970.
- Postman, Neil, "The First Curriculum: Comparing School and Television", Phi Delta Kappan, 61:3, November 1979.

This work is partially supported by NSF Grant SED-79-18991 ©

A PET "ANSWER BOX" PROGRAM FOR TEACHERS

THORWALD ESBENSEN
Coordinator of Elementary Curriculum
and Instruction, Edina Public Schools
Edina, Minnesota 55435

Lack of appropriate software has been a persistent problem for educators interested in using microcomputers to assist classroom instruction. This difficulty is one that is not likely to go away soon.

A great many companies are currently rushing in to fill the gap. But it will probably take several years before supply catches up with demand in this burgeoning new area of educational technology. Meanwhile, those of us who are promoting the use of micros for instruction can help teachers integrate their regular classroom materials with computer hardware in ways that will be immediately useful to students and teachers alike. This article briefly describes one such approach.

The public schools of Edina, Minnesota, make considerable use of microcomputers for instruction, particularly at the elementary level. Indeed, demand for these machines has been so great that by the fall of 1980 more than eighty computers (most of them PET micros) will be helping students improve their skills in the areas of capitalization, punctuation, spelling, language usage, and mathematics.

To assist in the accomplishment of this, the Edina system regularly offers its teachers opportunities to become participants in microcomputer workshops designed to integrate the use of printed instructional materials with micros. In particular, the author, who serves as an instructor at these workshops, has written a simple program called ANSWER BOX which has turned out to be both popular and effective.

ANSWER BOX assumes that students will bring printed instructional materials to the micro and type in their answers to problems at the computer keyboard. The computer then becomes a sophisticated response device, providing immediate reinforcement, keeping track of student progress, and summarizing learning results at the end of each lesson, including time on task.

In order to prepare ANSWER BOX programs, teachers need to have only the ability to type answers on data lines. No questions of copyright are involved. Nothing in the original printed material is copied or altered in any way. The answers to problems are simply entered into the computer on the appropriate data lines. The computer does the rest.

Let's see how this works. Look at Figures 1 and 2 below.

Figure 1 is a sample instructional exercise. It consists of fifteen problems. Each problem presents a group of words. Is the group of words a complete sentence? If so, the student types **YES** (and

presses the **RETURN** key). If not, the student types **NO** (and presses the **RETURN** key). If the student's answer is right, a smiling ANSWER BOX face appears while the student's name flashes on and off underneath it. If the student's answer is wrong, a frowning ANSWER BOX face appears with the word **WRONG**. Meanwhile, underneath the ANSWER BOX, the right answer flashes on and off. The student must then type the right answer before the computer will go to the next problem.

If the student does not know the answer to a problem, he/she may type the question mark (and press the **RETURN** key). The computer will then print the right answer. However, the student must also type the right answer before the computer will go to the next problem.

IDENTIFYING COMPLETE SENTENCES

Lesson 23

For each group of words, answer YES if the group forms a complete sentence. Answer NO if the group does not form a complete sentence.

1. Beyond the highest mountain that we could see
2. If there is the slightest doubt in your mind when you think about it
3. I will see him tomorrow
4. Last night under a yellow moon
5. She has seen enough trouble already
6. Although I did not know them well
7. In case you are ever interested in the results
8. Plan to go with me to the store
9. That sounds sensible
10. There is no point in talking about it
11. Overhead in the bright sunshine
12. When the last car raced across the finish line
13. After he received the mysterious letter in the mail
14. Don't tell me what to do
15. After she ate, she felt better

FIGURE 1

Figure 2 is a listing of the ANSWER BOX program. Let's examine it. The REM statements on Lines 10-60 explain how the answers to a printed exercise are to be entered on the appropriate data lines. Note that Lines 7000-7998 are to be used to enter the data.

It should be emphasized that a single ANSWER BOX program can be used to accommodate a multiplicity of printed exercises. Indeed, the author has more than once entered into one program the answers to all the exercises in a given workbook. As the REM statements indicate, the various groups of exercise answers must be separated by lesson numbers also

PET GET WITH FLASHING CURSOR

Gary Greenberg
35-63 80th St.
Jackson Hts., NY 11372

There are many reasons why some programmers prefer to use the GET statement for keyboard input rather than the INPUT statement. One reason of interest to many beginners is that the GET statement can help prevent falling out of the program when the wrong response is made. For example, pressing RETURN as a response to INPUT causes you to fall out of the program. Similarly if you call for a numeric variable and type an alphabetic character, again you are in trouble.

The GET statement works by checking the keyboard input buffer for the next character. However, without the benefit of appropriate software routines, the GET statement collects only one character, does not provide a cursor for a prompt, does not print the character on the screen and does not permit you to erase the result before entering the data. Additionally, the statement is executed so rapidly you will probably not be able to enter it in time to get it accepted. You do not use a carriage return to signal the end of the entry.

A number of magazines have provided software pieces to enable you to use the GET but they do not permit you to delete and correct the entry before entering it into the program. The following program permits you to use the GET statement instead of the INPUT statement. It will permit you to have a flashing cursor and it will permit you to delete and correct entries before committing them to the computer. You use the carriage return to signal the end of your entry. You will not fall out of your program if you respond with a carriage return.

Program Listing

```
100 PRINT "WHAT IS ANSWER?";GOSUB 1000
110 PRINT Z1$:Z1 = VAL(Z1$):PRINT Z1
1000 REM GET WITH FLASHING CURSOR
1010 Z$ = " ":Z1$ = ""
1020 PRINT "R rel";:FOR I = 1 TO 35:NEXT I
1030 PRINT "d";:FOR I = 1 TO 35:NEXT I
1040 GET Z$:IF Z$ = "" THEN 1020
1050 REM ERASE ENTRY CHECK
1060 IF Z$ <> CHR$(20) THEN 1110
1070 IF Z$ = "" THEN 1020
1080 ZZ = LEN(Z1$):IF ZZ < 1 THEN 1020
1090 Z1$ = LEFT$(Z1$,ZZ-1):PRINT "d";
1100 GOTO 1020
1110 IF Z$ = CHR$(13) OR Z$ = CHR$(14) THEN 1150
1120 PRINT Z$;
1130 Z1$ = Z1$ + Z$
1140 GOTO 1020
1150 GET Z$:IF Z$ = "" THEN 1150
1160 RETURN
```

The program is a subroutine that can be called in place of any INPUT statements. Here's how it works.

LINE 100: The print message is used as a prompt. GET does not provide a question mark and you will have to put it into the PRINT statement if you want it. After the prompt is printed the program jumps to the subroutine.

LINE 110: This line is the line after the subroutine is executed. You can use any program statements you want. The one here is just an illustration. The PRINT Z1\$ is redundant since it is printed out in the subroutine. The VAL statement is used to convert the STRING to a NUMERIC. You should note that the subroutine leaves the cursor immediately after the entry. If you want a linefeed you will have to insert a "PRINT:" in line 110.

LINE 1000: The subroutine starts here.

LINE 1010: Z\$ will be used to collect the data typed in. Z1\$ will be used to build a string out of the data entered. This line initializes both strings as Nulls (empty).

LINES 1020-1030: These lines simulate the cursor. The two FOR-NEXT routines are time delays. To speed up the flashing cursor, shorten the loops. To slow down the cursor, increase the number of loops. The PRINT statements produce a REVERSE FIELD, SPACE (becomes a solid block in Reverse field), REVERSE OFF, CURSOR LEFT. This is followed by the delay and then PRINT SPACE and CURSOR LEFT again followed by a delay. By using different characters instead of the space character you can create some interesting cursors. This produces an interesting wig-wag effect.

LINE 1040: The GET checks the keyboard buffer. If it is empty (null string) it starts the cursor flashing again while it waits for data. Once a character has been entered the program moves on to the next line where it begins to examine the nature of the character entered.

LINE 1050-1060: These lines check for a "delete".

LINE 1070: If "delete" is entered and there is no data entered the program returns to the flashing cursor.

LINE 1080: If data has been entered this line checks to see how long the data is. This check is to make sure that the "delete" does not go past the beginning entry point on the screen.

LINE 1090: The last character in the string is deleted. You can continue to delete characters until you have erased the whole string, and the program keeps checking for the delete every time you make an entry.

LINE 1100: You return to the flashing cursor waiting for the next entry.

LINES 1110-1140: These lines first check to see if you have hit "carriage return" or shifted "carriage return". If not, then the program adds Z\$ to Z1\$ to

keep building the string entry. After each character is added to Z1\$ the program returns to the flashing cursor. When the carriage return is pressed it is the signal that the entry is complete and you branch to 1150.

LINE 1150: This line is used to empty the buffer. Sometimes, when you enter data rapidly, there is information retained in the buffer that you haven't accessed. If you don't clear it out then the next time you call the routine, the old unused data will be entered in response to the GET command before you have a chance to use your own input.

LINE 1160: This returns control to the main body of the program at line 110. ©

COMPUTE'S BOOK CORNER

We Now Have One of the Best Collections of 6502 Resource Materials Around:

See our direct mail response card in this issue.

DUST COVERS

PET	\$11.95
DISK DRIVE	\$9.95
TRACTOR FEED PRINTERS	\$9.95
ALL THREE COVERS ONLY	\$28.95

HOUSE OF COMPUTERS inc.

368 EGLINTON AVE. W. (at Avenue Rd.)
TORONTO, ONTARIO M5N 1A2 (416) 482-4336

NAME: _____
 ADDRESS: _____
 CITY: _____ PROVINCE: _____ PC: _____
 CHARGE#: _____
 MASTER CHARGE#: _____
 EXPIRY DATE: _____

HOW MANY	DESCRIPTION	PRICE EACH	TOTAL

TOTAL MERCHANDISE _____
 ONTARIO SALES TAX 7% _____
 SHIPPING & HANDLING 5% _____
 TOTAL ENCLOSED _____

MicroMedia Micro-Computer Software

PROGRAMS IN • VARIABLE SPEED READING •
 WORD RECOGNITION • LIBRARY SKILLS •
 MATHEMATICS • SPELLING

EDUCATIONAL PROGRAMS FOR THE PET^{T.M.}

MULTI-LEVEL, MULTI-DISCIPLINE PROGRAMS TO BE USED WITH SINGLE STUDENTS OR WITH GROUPS..... PERSONALIZED PROGRAMS WHICH CAN BE TAILORED TO INDIVIDUAL STUDENT NEEDS..... PROGRAMS PRICED FROM \$7.95!!
 MICRO PROGRAMS FOR EDUCATORS... BY EDUCATORS

SEND FOR YOUR FREE COPY OF OUR CATALOG:

Micro Media P. O. Box 59..... Vicksburg, Michigan 49097

SOFTWARE SPECIALISTS

MICROPHYS PROGRAMS

SCIENCE AND EDUCATION

2048 FORD STREET

Mp

BROOKLYN, NEW YORK 11229 (212) 646-0140

Microphys has designed a program to create cryptograms from various lines of text which are entered by the user. The enclosed cryptogram is then displayed along with its unique cryptogram code number. To decode the cryptogram, the program is run from line 9000 as described below.

The message to be encoded should be entered by user #1. The computer will then generate the cryptogram which should be deciphered by user #2.

To receive assistance in decoding, or to have the entire cryptogram deciphered, user #2 should run the program from line 9000. The computer will request the entry of the cryptogram code number and then the entry of the lines to be decoded. User #2 may enter a single letter, a word, or the complete text to be decoded. The computer will respond by displaying the corresponding deciphered letter, word, or text.

The program will permit user #1 to create an encoded message which he may mail or transmit to user #2, assuming both users have access to the cryptogram program. The code number should also be included with the message in order to permit user #2 to have his computer decode the message if he encounters difficulty.

The cryptogram program is designed for use with either 8K or 16/32K PET computers. It is provided on cassette tape; comes with complete instructions; and sells for \$20. It may be obtained from your local computer dealer or, if unavailable, it may be purchased directly from Microphys.

Note: A free, educational software catalogue is available upon request from Microphys. This catalog describes over 140 programs currently available.

PUT YOUR PET ABOVE THE CROWD!

Link it with GPA ELECTRONICS'
Programmable, Intelligent I/O.



Not just a
telecommunications
I/O. Not just an
intelligent hard copy
interface. GPA's
Intelligent I/O is a
**COMPLETE
MICROCOMPUTER**
on a 4½"x7" card!

*Programmable via Resident Monitor in PROM,
the Intelligent I/O puts your PET
in communication with the real world,
or with other computers, large or small.*

FEATURES:

- ★ 6502 Microprocessor.
- ★ 2K E-PROM; 1K RAM as buffer.
- ★ Fully IEEE-488 compatible and addressable.
- ★ Serial and parallel I/O through four ports. Device can communicate with two peripherals simultaneously; RS-232 devices can communicate with parallel devices.
- ★ Hard copy interfacing with either RS-232 or 20mA devices (Please specify.)
- ★ Accommodates all baud rates to 9600.
- ★ Selectable line feed, carriage return delay and characters per line.
- ★ Supports standard EIA modem-control signals.
- ★ Handshaking, of course.
- ★ Functions as Data Channel, SPOOLER or Programmable Filter.
- ★ Remote access to Basic.
- ★ Fully disk compatible.
- ★ Will provide secure, encrypted telecommunications with optional programming.
- ★ Complete dial-up and time sharing functions.
- ★ Allows ganging of microcomputers for multi-processing.
- ★ Accesses and controls servos, sensors, articulated devices or transducers (with appropriate firmware, available from GPA.)
- ★ Functions as disk controller, resident assembler, E-PROM burner (with optional firmware.)
- ★ Integral power supply (5VDC @ 350mA.) Completely portable, stand-alone computer.
- ★ Fully documented, tested and guaranteed.

See your dealer today, or order direct from GPA.

Just \$259.95 (110VAC) or \$279.95 (250VAC)



P. O. Box 931
Laytonville, CA 95454
(707) 984-6270



* PET is a registered trade mark of Commodore Business Machines.

Two "Mini" Reviews:
Robert Lock, Editor

ATARI BASIC CARDS 24 pages, \$4.95 **Micronotions** **1929 Northport Drive #6** **Madison, Wisconsin 53704**

Len Lindsay's Atari Basic Cards are simply that. . . a comprehensive heavy-paper booklet covering the commands and syntax of Atari BASIC. The preliminary copy I read was a handy size, 4¼" by 11" with four commands per page. The back of each page is left blank so the user may jot in his or her own helpful hints. The command sections are identical in size and are arranged so you can cut them out, if you prefer, and use a small card file for reference.

Each command is presented with syntax, an example of use and brief definition. Best of all for beginners— and aren't we all at this point— is the "see also" cross reference presented with most of the commands.

Although the booklet isn't typeset, the reproduced printer output is extremely clear and easy to read. At \$4.95 (approximately) Atari Basic Cards is a recommended addition to the small (but growing) amount of Atari information available.

A Pre-review Review. . .

Mailing List \$99.95 **Dr. Daley's Software** **425 Grove Ave.,** **Berrien Springs, MI 49103**

I haven't time this issue to give a real review of Mailing List, but felt it was important enough to comment on. Richard Daley is adopting a style of programming that I think is important. His mailing list program is designed so we, the users, have a great deal to say in structuring our files and defining how we want our data base to look. You can define your own sort keys, pull out subsets, etc. We are currently using it, with some in-house output modifications, to maintain our whole dealer data base on a 32K CBM with attached disk drives and NEC Spinwriter.

I asked Joretta Klepfer to look over my comments and here are hers:

You might add that it is easy to do editing, updating, maintenance and back-up of data files.

You can store an output format file on disk.

Even more, you can create your own format of the data for printing.

Okay. Thanks, Jo. We'll look forward to your review next time.

©

Get a load of this . . . Instant Software™

Ask for Instant Software at a computer store near you.

PET UTILITY I You're working under a serious handicap if you can't write programs in machine language. The PET Utility I package gives you the tools you need:

- **Monitr**—The Monitr program lets you write, edit, save, and verify any machine language and/or BASIC program. Just load and run the Monitr program and then load the program you want to edit.
- **Programmer's Calculator**—This program will convert numbers into the binary, octal, decimal, and hexadecimal systems and function as a floating point calculator. It will also display all four numbering systems simultaneously and allow you to handle large numbers limited only by the size of your screen. For the 8K PET. Order No. 0105P. \$9.95.

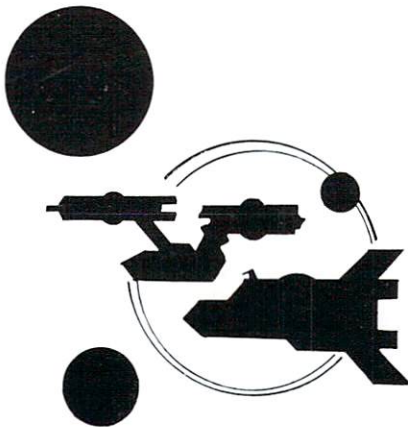

SPACE WARS You must protect your planet against a wide variety of alien attacks. Included are:

- **Space War**—One or two players can pilot their saucers and duel with laser beams or shoot stars.
- **Star Ship Attack**—Your mission is to protect the food station satellites from destruction by the enemy star ship. You must capture, destroy, or drive off the attacking ship.
- **Battlefield**—Guess the location of the four enemy divisions and destroy them before your forces are wiped out.

Engaging in battle requires the Apple 8K and Integer BASIC. Order No. 0096A \$7.95.

ACCOUNTING ASSISTANT This package will help any businessman solve many of those day-to-day financial problems. Included are:

- **Loan Amortization Schedule**—This program will give you a complete breakdown of any loan or investment.
- **Depreciation Schedule**—You can get a depreciation schedule using any one of the following methods: straight line, sum of years-digits, declining balance, units of production, or machine hours.

This package is available for both the PET and Apple. It requires the Apple 16K and Apple-soft II BASIC. Order No. 0088A \$7.95 or the PET 8K. Order no. 0048P \$7.95.

MIMIC Test your memory and reflexes with the five different versions of this game. You must match the sequence and location of signals displayed by your Apple. You'll need an Apple with 24K and Integer BASIC. Order No. 0025A \$7.95.

HAM PACKAGE I This versatile package lets you solve many of the problems commonly encountered in electronics design. With your 8K PET, you have a choice of:

- **Basic Electronics with Voltage Divider**—Solve problems involving Ohm's Law, voltage dividers, and RC time constants.
- **Dipole and Yagi Antennas**—Design antennas easily, without tedious calculations. This is the perfect package for any ham or technician. Order No. 0054P \$7.95.

SAHARA WARRIORS Enjoy all the gritty realism of desert warfare:

- **Commando**—You must send your commandoes to trap a German general and cut him off from his troops.
- **French Foreign Legion**—The battalions of the French Foreign Legion are in a race with the Arabs. Which side will get its battalions into the oasis in the shortest time? You and a friend can find out.

Both programs in this package require an Apple 8K and Integer BASIC. Order No. 0080A \$7.95.

MORTGAGE WITH PREPAYMENT OPTION/ FINANCIER These two programs will more than pay for themselves if you mortgage a home or make investments:

- **Mortgage with Prepayment Option**—Calculate mortgage payment schedules and save money with prepayments.
- **Financier**—Calculate which investment will pay you the most, figure annual depreciation, and compute the cost of borrowing, *easily and quickly*.

All you need to become a financial wizard with a 16K Apple and Integer BASIC. Order No. 0094A \$7.95.



CODE NAME: CIPHER Enjoy that same feeling of intrigue and discovery with the Code Name: Cipher package. Included are:

- **Memory Game**—Would you like to match your memory against the computer's? You can with the Memory Game.
- **Codemaster**—One player types in a word, phrase, or sentence, and the PET translates that message into a cryptogram. The other player must break the code and solve the cryptogram in the shortest time possible.
- **Deceitful Mindmaster**—This isn't your ordinary Mastermind-type game. You must guess the five letters in the hidden code word.

• **Code Breaker**—Cracking this code won't be as easy as cracking walnuts. You'll need to flex your mental muscles to win this game.

If you want a mental challenge, then Code Name: Cipher is for you. For the 8K PET. Order No. 0112P. \$7.95.

TO ORDER:

Look for these programs at the dealer nearest you (See the list on the next page). If your store does not stock Instant Software send your order with payment to:

Instant Software Inc.
Order Dept.
Peterborough, N.H. 03458
(Add \$1.00 for handling)

or call toll-free 1-800-258-5473 (VISA, Master Charge and American Express accepted).

Ask your local dealer for the latest Instant Software catalog or write: Instant Software Catalog Dept., Peterborough, N.H. 03458

Copyright 1980 by Instant Software Inc.
Peterborough, New Hampshire 03458

All Rights Reserved

Instant Software™ Inc.

Peterborough, New Hampshire 03458 603-924-7296

Ask for Instant Software at a computer store near you.

Alabama

Anderson Computers
3156 University Dr., Huntsville
Computerland of Huntsville
3020 University Dr., Huntsville
Olensky Bros.
3763 Airport Blvd., Mobile

Arizona

Ham Shack
450 6-A N. 16th St., Phoenix
Millets TV & Radio
621 East Broadway, Mesa

California

Byte Shop of Fairfield
87 Marina Center St., Suisun City
Byte Shop
8038 Clairmont Mesa Blvd.,
San Diego
Byte Shop of Mt. View
1415 West El Camino Real, Mt. View
Byte Shop of Sacramento
6041 Greenback Ln., Citrus Heights
Capital Computer Systems
3396 El Camino Ave., Sacramento
Computers Made Easy
819 East Ave. Q-9, Palmdale
Computer Store of San Leandro
701 MacArthur Blvd., San Leandro
Computer World
6791 Westminster Ave., Westminster
Computerland
16720 S. Hawthorne, Lawndale
Computerland of W. LA
6840 La Cienega Blvd., Inglewood
Coast Electronics
3118 No. Main St., Morro Bay
Computerland
24001 via Fabricante No 904,
Mission Viejo
Hobbytronics
1378 So. Bascom Ave., San Jose
Hobby World
19511 Business Ctr. Dr., Unit 6
Bortheridge
I.C.E. House Inc.
398 North E. St., San Bernardino
Jade Computer Products
4901 W. Rosecrans, Hawthorne
Opamp/Technical Books
1033 N. Sycamore Ave., Los Angeles
Q.I. Computers, Inc.
15818 Hawthorne Blvd., Lawndale
Radio Shack Dealer
8250 Mira Mesa Blvd., San Diego
Radio Shack Dealer
50 N. Cabrillo Hwy., Half Moon Bay
Santa Rosa Computer Center
604 7th St., Santa Rosa
Silver Spur Elect. Comm.
13552 Central Ave., Chino
The Computer Store
820 Broadway, Santa Monica

Colorado

Byte Shop
3464 S. Acoma St., Englewood
Colorado Computer Systems
311 W. 74th Ave., Westminster
Computerland of North Denver
8749 Wadsworth Blvd., Arvada
Computer Shack
1635 South Prairie, Pueblo
The Computer Store
2300 Welton St., Denver

Connecticut

American Business Computers
454 Thames St., Groton
Computerlab
130 Jefferson, New London
Computerland
1700 Post Rd., Fairfield
Computer Works
1439 Post Rd. E., Liberty Plaza,
Westport

D.C.

The Program Store
4200 Wisconsin Ave., N.W.,
Washington, D.C.

Florida

Adventure International
200 Bald Cypress Ct., Longwood
AMF Electronics
11146 N. 30th St., Tampa
Boyd-Ebert Corporation
1328 West 15th St., Panama City
Computer Center
6578 Central Ave., St. Petersburg
Computerland of Ft. Lauderdale
3963 N. Federal Hwy., Ft. Lauderdale

Georgia

Atlanta Computer Mart
Atlanta
Computerland of Atlanta
2423 Cobb Parkway, Smyrna
Hawaii
Computerland of Hawaii
567 N. Federal Hwy., Honolulu
Radio Shack Assoc. Store
1712 S. King St., Honolulu

Idaho

Electronic Specialists
8411 Fairview Ave., Boise
Illinois
Computerland
4507 North Sterling, Peoria
Computerland
9511 N. Milwaukee Ave., Niles
Computer Station
3659 Nameoki Rd., Granite City
Midwest Micro Computers, Inc.
708 S. Main St., Lombard

Indiana

Computer Center of South Bend
51591 US 31 North, South Bend
Data Domain
221 W. Dodds, Bloomington
Fall Creek Electronics Store
732 Center St., Pendleton
Iowa
Memory Bank
4128 Brady St., Davenport
Kansas
Central Kansas Computers
6 S. Broadway, Herington
Louisiana
Computer Shoppe Inc.
3225 Danny Park, Suite 222, Metairie

Maine

Radio Shack
315 Main Mall Rd., Portland
Maryland
Jack Fives Electronics
4608 Deblen Circle, Pikesville
The Comm Center
9624 Ft. Meade Rd., Laurel
Massachusetts
ComputerCity
175 Main St., Charlestown
ComputerCity
50 Worcester Rd., Framingham
Computerland of Boston
214 Worcester Rd., Wellesley
Computer Packages Unlimited
244 W. Boylston St., West Boylston
Lighthouse Computer Software
14 Fall River Ave., Rehoboth
New England Electronics Co.
679 Highland Ave., Needham
The Computer Store
120 Cambridge St., Burlington
Tufts Radio & Electronics
206 Mystic Ave., Medford

Michigan

Computer Center
28251 Ford Rd., Garden City
Computer Connections
38437 Grand River, Farmington Hills
Computerland of Grand Rapids
2927 28th St. S.E., Kentwood
Computerland of Rochester
301 S. Livernois, Rochester
Computerland of Southfield
29673 Northwestern Hwy., Southfield
Computer Mart
560 W. 14 Mile Rd., Clawson
Hobby House
1035 W. Territorial Rd., Battle Creek

Minnesota

The Alternate Source
1806 Ada, Lansing
Ye Olde Teacher Shoppe
1823 Wilmyre St., Ypsilanti
Computerland of Hopkins
11319 Hwy F., Hopkins
Digital Den
Burnsville Center
Minnesota Software Inc.
5422 Fisher St., White Bear Lake
Zim Computers
5717 Xerxes Ave., N. Brooklin Center
Mississippi
Dyer's, Inc.
200 E. Main St., West Point
W. Vernon Foster Inc.
816 Foley St., Jackson
Missouri
Computervan, Inc.
51 Florissant Oaks Shopping Center
Florissant
Consolidated Software
16501 Greenwald Court, Belton
Missouri
Computerland of Hopkins
11319 Hwy F., Hopkins
Digital Den
Burnsville Center
Minnesota Software Inc.
5422 Fisher St., White Bear Lake
Zim Computers
5717 Xerxes Ave., N. Brooklin Center

Nebraska

Computerland of Omaha
11031 Elm St., Omaha
Midwest Computer Co. Inc.
86251 St., Omaha
Midwest Computer Co. Inc.
4442 S. 84th St., Omaha
Midwest Computer Co. Inc.
4403 S. 87th St., Omaha
Nevada
Century 23
4566 Spring Mountain Rd., Las Vegas
New Hampshire
Bitsbytes Computer Center
568 Pleasant St., Concord
ComputerCity
1525 S. Willow, Manchester
Paul's TV
Main St., Fremont
Portsmouth Computer Center
31 Raynes Ave., Portsmouth
Radio Shack Assoc. Store
Fairbanks Plaza, Keene
New Jersey
Computer Encounter
2 Nassau St., Princeton
Computerland
35 Plaza Rte. #4, W. Paramus
Computer Mart of NJ
501 Rte. 27, Iselin
Dave's Electronics
Pennsville Shopping Ctr., Pennsville
Personal Computing Inc.
51 Central Sq., Linwood
Radio Shack/J&J Electronic
Mansfield Shopping Ctr.
Rt. 57 Allen Rd., Hackettstown
The Bargain Brothers
Glen Roc Shopping Center
216 Scotch Road, Trenton
The Computer Emporium
Bldg. 103, Avenues of Commerce
2428 Rte. 38, Cherry Hill
New Mexico
Antel Electronics Co.
232 Wisconsin N.E., Albuquerque
Legay and Associates
2908 Tahiti Ct. N.E., Albuquerque
Mitchell's Music (Radio Shack)
407 W. Church, Carlsbad
South West Computer Center
121 Wyatt Drive, Suite 7, Las Cruces
New York
Aristo Craft
314 Fifth Ave., NYC
Bits & Bytes
2800 Straight Rd., Fredonia
Computer Corner
200 Hamilton Ave., White Plains
Computer Era Corp.
1570 3rd Ave., New York
Computer Factory
485 Lexington Ave., NYC
Computer House, Inc.
721 Atlantic Ave., Rochester

North Carolina

Byte Shop of Raleigh
1213 Hillsborough St., Raleigh
Ohio
Altair Business Systems, Inc.
5252 North Dixie Dr., Dayton
Astro Video Electronics
504 E. Main St., Lancaster
Cincinnati Computer Store
4816 Interstate Dr., Cincinnati
Computerland
4579 Great Northern Blvd.,
N. Olmstead
Computerland
6429 Busch Blvd., Columbus
Computerland
1288 Som Rd., Mayfield Heights
Computer Store of Toledo
18 Hillwyck Dr., Toledo
Forbes Microsystems Inc.
35 N. Broad, Fairborn
Microcomputer Center
7900 Paragon Rd., Dayton
Micro-Mini Computer World
74 Robinwood, Columbus
Universal Amateur Radio, Inc.
1280 Aida Dr., Columbus
Oklahoma
Sounds, Etc.
Hwy. 33, Watonga
Vern Street Products
Radio Shack Dealer
114 W. Taft St., Sapulpa
Oregon
Computerland of Portland
12020 S.W. Main St., Tigard
Computer Pathways Unlimited, Inc.
2151 Davcor St. S.E., Salem
Pennsylvania
Audio Mart
518 Fifth Ave., New Brighton
Artco Elect.
302 Wyoming Ave., Kingston
Artco Elect.
Back Mountain Shop. Ctr.
Shavertown
Computer Workshope
3848 William Penn Hwy, Monroeville
Computerland of Harrisburg
4644 Carlisle Pike, Mechanicsburg
Erie Computer Co.
2127 West 8th St., Erie
Mighty Byte Computer Center
537 Easton Rd., Hersham
Personal Computer Corp.
24-26 West Lancaster Ave., Paoli
Personal Computer Corp.
Frazier Mall, Lancaster Ave., Frazier
Rhode Island
Computer City
165 Angell St., Providence
South Dakota
CB Radio Shack
2121 and Broadway, Yankton
Tennessee
Computerlab
671 S. Menden Hall Rd., Memphis
H & H Electronics Inc.
509 N. Jackson St., Tullahoma
Texas
Computer Port
926 N. Collig, Arlington
Houston Microcomputer Tech.
5313 Bissonnet, Bellaire
K.A. Elect.
9090 Stemmons Frwy., Dallas

Pan American Elect. Inc.

1117 Conway, Mission
Radio Shack Dealer
21969 Katy Freeway, Katy
Ram Micro Systems
6353 Camp Bowie Blvd., Ft. Worth
Utah
Quality Technology
470 E. 2nd So., Salt Lake City
Virginia
Home Computer Center
2927 Virginia Beach Blvd.
Virginia Beach
Southside Radio Comm.
135 Pickwick Ave., Colonial Heights
Washington
American Mercantile Co. Inc.
2418 1st Ave. S., Seattle
Byte Shop of Bellevue
14701 N.E. 20th St., Bellevue
Computerland of South King Co.
1500 S. 336 St., Suite 12
Federal Way
Magnolia Micro Systems
2812 Thornndyke Ave., Seattle
Personal Computers
S 104 Freya, Spokane
Ye Old Computer Shop
1301 G. Washington, Richland
West Virginia
The Computer Corner Inc.
22 Beechurst Ave., Morgantown
The Computer Store
Municipal Parking Bldg., Charleston
Wisconsin
Byte Shop Of Milwaukee
6019 West Layton Ave., Greenfield
Computerland
690 S. Whitney Way, Madison
Petted Microsystems
4265 W. Loomis Rd., Milwaukee

Puerto Rico

The Microcomputer Store
1568 Ave. Jesus T. Pinero
Caparra Terrace
Canada
CANADIAN DISTRIBUTORS:
Micron Distributing
409 Queen St., W. Toronto, Ont.
M5V 2A5
Computerland of Winnipeg
715 Portage Ave., Winnipeg, Man.
Compumart
411 Roosevelt Ave., Ottawa, Ontario
Computer Mart. Ltd.
1055 Yonge St., Suite 208
Toronto, Ontario
Galactia Computers
103rd Ave., Edmonton, Alberta
Micromatic Systems Inc.
101 8136 Park Rd., Richmond, B.C.
Micro Shack of W. Canada
333 Park Street, Regina, Sask.
Orthon Holdings Ltd.
12411 Stony Plain Road
Edmonton, Alberta
Total Computer Systems
Ajax, Ontario
England
Tamays & Farr Ltd.
4 Morgan St., London
France
Sided
45 Rue de la Chapelle, Paris
Sivea s.a.
20, Rue de Leningrad, Paris
Italy
HOMIC s.r.l.
Piazza De Angeli 1, Milano
West Germany
Electronic Hobby Shop
Kaiserstr. 20, Bonn
MicroShop Bodensee
Markstr. 3, 7778 Markdorf
Australia
Computerware
62 Paisley St., Footscray VIC
Deforest Software
36 Glen Tower Drive
Glen Waverly, VIC.
Softronics Micro Systems
Lindfield
Sure-Load Software
P.O. Box 26, Weston, A.C.T.

South Africa

Eddie Talberg
P.O. Box 745, Johannesburg

Instant Software Inc.

Peterborough, New Hampshire 03458 603-924-7296

Have You Been Bitten By The Computer Bug?

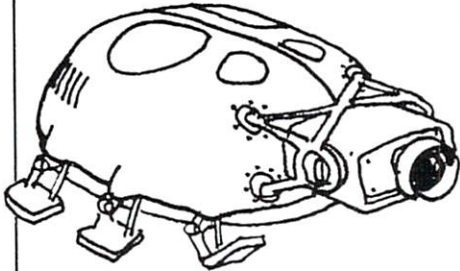

Be A Computer Literate

A first introduction to the computer world for children age 10 to 14. Full color diagrams, drawings, photos and large type make this book easy to read and understand. Written by Marion J. Ball and Sylvia Charp. This informative 62-page book is used in many school systems. Softbound [6H] \$3.95.

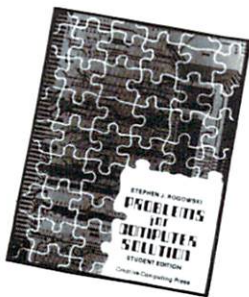

Problems for Computer Solution

Problems for Computer Solution by Stephen J. Rogowski is an excellent source of exercises in research and problem solving for students and self-learners. Problems like the Faulty Speedometer Spotter make learning fun and easy. 104 pages, softbound, [9Z] \$4.95.



Creative Computing Magazine

Creative Computing has long been Number 1 in applications and software for micros, minis, and time-sharing systems for homes, schools and small businesses. Loads of applications every issue: text editing, graphics, communications, artificial intelligence, simulations, data base and file systems, music synthesis, analog control. Complete programs with sample runs. Programming techniques: sort algorithms, file structures, shuffling, etc. Coverage of electronic and video games and other related consumer electronics products, too.

Just getting started? Then turn to our technology tutorials, learning activities, short programs, and problem solving pages. No-nonsense book reviews, too. Even some fiction and foolishness.

Subscriptions: 1 year \$15, 3 years \$40. Foreign, add \$9/year surface postage, \$26/year air.

Basic Computer Games

Edited by David Ahl, this book contains 101 imaginative and challenging games for one, two, or more players — Basketball, Craps, Gomoko, Blackjack, Even Wins, Super Star Trek, Bombs Away, Horserace. Simulate lunar landings. Play the stock market. Write poetry. Draw pictures.

All programs are complete with listing in Microsoft Basic, sample run and description. Basic conversion table included. 125,000 copies in print. 192 pages softbound. [6C] \$7.50.



More Basic Computer Games

Contains 84 fascinating and entertaining games for solo and group play — evade a man-eating rabbit, crack a safe, tame a wild horse, become a millionaire, race your Ferrari, joust with a knight, trek across the desert on your camel, navigate in deep space.

All games come complete with program listing in Microsoft Basic, sample run and description. 192 pages softbound. [6C2] \$7.50.



The Best of Creative Computing

The first two years of **Creative Computing** magazine have been edited into two big blockbuster books. **American Vocational Journal** said of Volume 1, "This book is the 'Whole Earth Catalog' of computers." [6A] Volume 2 continues in the same tradition. "Non-technical in approach, its pages are filled with information, articles, games and activities. Fun layout." —**American Libraries**. [6B] Each volume \$8.95.

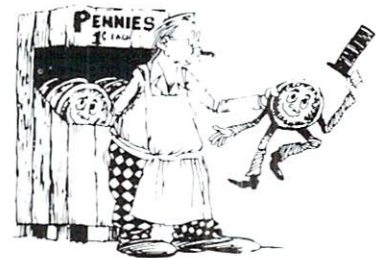

Computer Coin Games

Computer Coin Games by Joe Weisbecker aids newcomers to the field of computers by simplifying the concepts of computer circuitry through games which can be played with a few pennies and full sized playing boards in the book. Enhanced by outrageous cartoons, teachers, students and self-learners of all ages will enjoy this 96 page softbound book. [10R] \$3.95.

How To Order

Send order and payment to **Creative Computing**, P.O. Box 789-M, Morristown, NJ 07960. Add \$1.00 shipping and handling per order (foreign, \$2.50) N.J. residents add 5% sales tax. Visa, MasterCard and American Express orders welcome. For faster service, call in your bank card order toll free to: 800-631-8112. (In NJ, call (201) 540-0445.)

creative computing

THE CONSUMER COMPUTER

Len Lindsay
1929 Northport Drive #6
Madison, WI 53704

Summer is almost upon us. Watch for a burst of activity in the software and computer accessories markets. Read the new ads & announcements with care.

A review will help put a perspective on the product, but the best thing is to see it operating before you buy it. That's one good reason to buy from your local computer store.

IRIDIS #1

The first issue of IRIDIS has now been shipped by THE CODE WORKS (Box 550, Goleta, CA 93017). I have a copy and enjoyed it very much. IRIDIS is a set of four programs on tape (or disk) accompanied by a booklet containing the complete listings for the programs as well as a line by line explanation of how the programs work. The best way to learn how to write your own programs is to look at other good programs. IRIDIS is an excellent way to do this, since the programs are well done, and fully explained. The IRIDIS booklet also features short articles explaining various aspects of your ATARI computer.

The first four programs may not be earth shattering, but they show some of the things that can be accomplished with an ATARI computer. The first program, **CLOCK**, illustrates how to use ATARI timer functions. It makes use of sound and fine graphics to create a chiming clock. The time is not shown with digital letters, but with the old fashioned hour, minute, and second hands.

LOGO illustrates how to use ATARI graphic commands to plot, draw and fill. It shows you how fast the color of any area can change due to ATARI's method of using Registers to store color information.

POLYGONS draws some very beautiful and intricate patterns on your screen. You watch it as it draws the pattern, then a few seconds after it is complete, it is erased and a new and different pattern is drawn. This is a good demonstration of high resolution graphics.

ZAP is the only program that allows participation. You use a joystick in this game to control a worm which constantly keeps moving around the screen. Target squares appear randomly. You try to maneuver your worm to hit the targets before they disappear. You get points for each target you "eat", and your worm grows longer as well. If your worm ever bumps into itself in its travels, the round is ended. The game is over after 5 rounds.

That's IRIDIS #1. It is available for \$9.95 on cassette or \$12.95 on diskette. It is a good way to learn about your computer, and add 4 good programs to your program library.

ATARI BASIC CARDS

Another aid to ATARI users who are hoping to learn how to program in BASIC is ATARI BASIC CARDS. Since I was the author of this booklet, I can't give you an unbiased review, but COMPUTE was given a copy for review. It is available from MicroNotions, (1929 Northport Drive, Room 6, Madison, WI 53704) for \$5.

PROGRAMMA Emerges

PROGRAMMA INTERNATIONAL (3400 Wilshire Blvd, Los Angeles, CA 90010) is one of the largest personal computer software houses. They strive for quality programs and customer satisfaction. They now are supposed to have ATARI programs ready for release. Plus some very exciting programs for the PET/CBM. This includes "TALKING CALCULATOR" for the PET. PET users may be in for some more excitement very soon.

AUTOMATED SIMULATIONS

Automated Simulations (1902 Old Middlefield Way, Suite 15, Mountain View, CA 94043) has some new additions to its excellent line-up of programs for the PET and APPLE. COMPUTE #1 provided a full page review of their DUNJONQUEST program Temple of Apshai. Now they are offering LOWER REACHES OF APSHAI, a data tape (disk) for use with the Temple of Apshai program. Computer Role Playing addicts will rejoice with this extension of a great simulation.

If you aren't familiar with Role Playing, and want to ease into it (instead of taking on the full blown Temple of Apshai) I have reviewed their two MICROQUEST games, Datestones of Ryn and Morlocs Tower. They now are almost finished with a science fiction adventure, Rescue at Rigel. I will keep you posted about these sophisticated simulation games.

The Word Is Out

Dymax is coordinating a series of more than 10 books for PET, ATARI, APPLE and RADIO SHACK. The books are user oriented and should be a good source of information. Each book is written by a TEAM of authors, usually 3 or 4. This provides feedback for each co-author as well as several perspectives on the books content. I am familiar with this because I am a co-author for the **ATARI GAMES AND RECREATIONS** book and lead author for the **PET GAMES AND RECREATIONS** book. Both books should be available this winter, along with some of the other Dymax books. (Editors Note: Watch COMPUTE for preliminary reviews. RCL)

ATARI CHESS

The ATARI CHESS cartridge for the ATARI 400 or 800 computers is now available, and I have used one in my system at home. The chess board is a green and gold checkerboard with a maroon border. The pieces are black and white, and make use of ATARI's high resolution graphics for easily identifiable pieces. A blue box or "cursor" is used to show where on the board you are. That makes 6 different colors displayed at once on the screen - quite amazing, considering that there are only 5 color registers. (NOTE: exact colors vary from TV to TV).

You use a joystick to move your pieces. This may sound weird, but it is very easy, and reliable. (Just sit back in a comfortable chair with the joystick, and challenge the ATARI.) I have played the other chess games, and communicating grid locations to the computer is a chore. The ATARI method is so simple, even a young child can play. And there are 8 levels of difficulty, to satisfy all ranges of players, even those just learning to play. As the level goes up, the ATARI thinks longer about its move. According to the documentation, the lowest level (level 0) averages about 15 seconds per move. The next level (level 1) averages 30 seconds per move. Level two averages 45 seconds, level 3 - 2½ minutes, level 4 - 3 minutes, and level 5 about 10 minutes. The two remaining levels take quite a bit of thinking time, and would be only for the very serious player. Level 6 takes about 9 hours per move, and level 7 about 10 hours per move. The skill level can be changed at any time during the game if desired. In my games at level 1 it took about 10 seconds per move - at level 2 about 15 seconds - about 3 times faster than stated in the documentation.

Moving a piece is a very simple matter. You simply move the "cursor" to the top of the piece you wish to move. The cursor moves box by box, controlled by a joystick. When the cursor is on top of any piece it blinks, alternating box and piece to allow you to see both the cursor and the piece on the square. The cursor will continue moving from square to square until you hit the red controller button. If the cursor is over one of your pieces, the piece will go into blink mode. You now move the piece by joystick control while the cursor remains in the original location for reference. When the piece is where you want it, simply hit the red controller button again and the move is made, unless it is an illegal move. The ATARI will not allow you to make an illegal move, but beeps to tell you to try again.

ATARI CHESS includes many polishing touches that make playing enjoyable, and less frustrating. If you are put into check, your king begins flipping around, inside its square, softly beeping (you will not be able to miss it). Anytime you move a piece that would leave your king in check the word CHECK appears in the top corner advising you of this situation.

Perhaps the nicest feature of ATARI CHESS is that you can leave to get a sandwich while the ATARI is thinking about its move, and when you come back you will know just what piece it moved. It puts the "cursor" in the piece's original location and blinks the piece in its new location. The cursor and blinking remain on until you move the joystick (then the piece remains in its new location and the cursor follows your control).

You can play the white or black pieces, with white going first. If you wish to set up a particular chess situation, simply hit the "S" key on the keyboard, and place or delete pieces anywhere on the board, again under joystick control. Hit any other key when the set-up is as you like it. This is nice, if you would like to redo a move (after you saw how ATARI clobbered you) - simply put ATARI's piece back, and replace yours. Castling and En Passant capturing are allowed and explained in the documentation.

ATARI CHESS plays a fairly good game in its lower levels. I leave testing the top levels to someone with more time, since it takes so long to make its moves. At the easiest levels it would be a good way to learn how to play chess, for it will not let you make an illegal move, and it doesn't think too long about its own moves.

ATARI CHESS vs SARGON 2

I took my ATARI computer (and ATARI CHESS) over to a friend's and challenged his TRS-80 SARGON 2. We played two games. The first game was SARGON 2 at level 0 and ATARI CHESS at level 1. This seemed to be an even match - both took about 6 seconds per move, until the end when ATARI took about 20 seconds each for a few moves. After 17 moves, each side had 13 pieces left. Move 18 was very bad for ATARI - it missed taking SARGON's queen with a pawn (and no threat afterwards either). After 68 moves the winner was ATARI CHESS.

That called for a rematch. SARGON 2 was set to level 1 and ATARI CHESS at level 2. This time the difference in thinking times was noticeable. The first 20 moves ATARI CHESS took only about 7 seconds per move, while SARGON took about 26 seconds. The rest of the game, SARGON generally took a bit longer thinking time. The extra thinking time must have paid off, since SARGON 2 won after 60 moves. They traded queens on the eighth move.

This match pointed out some of the cosmetic advantages of ATARI CHESS. Its graphics were far superior, and easy to follow. My friend would use my ATARI CHESS moves as input for his move against SARGON 2. I in turn would take SARGON's move as input to ATARI CHESS. The ease of entering moves with a joystick for ATARI CHESS was quite evident - I was relaxing on the floor 6 feet from the 25 inch color TV with my joystick, while my friend sat next to the TRS-80 continually calculating the pieces starting and ending grid positions. ©

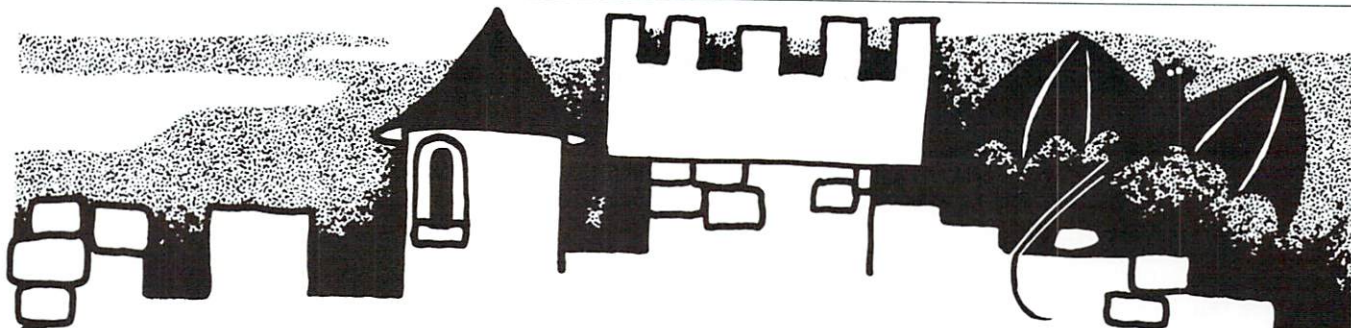

Did you read about the Dungeonmaster who became so enchanted playing a real life version of Dungeons and Dragons that he disappeared for a month?

You'll be able to hold on to reality just a little better when you play the Dunjonquest™ computer version, the greatest of all the role-playing fantasies.

But don't bet on it.

Sit at your computer. You're the hero. Enter the Dunjonquest "Temple of Apschai" and into the greatest fantasy adventure you've ever experienced. The Temple has over 200 rooms and catacombs in which lurk more than 30 kinds of monsters and beasts ready to do you in—in real time—before you can reach any of the 70 or so treasures waiting for the hero. You may spend days, weeks, months... the rest of your life... striking at the forces of evil, or running from them, or calling on powers you can never completely understand. Always, always demonstrating in varying degrees your strength, constitution, dexterity, intelligence, intuition, the force of your ego.



Unlike chess or bridge or monopoly, this role-playing game—like other good role-playing games—is an **experience** rather than a game: it is not played so much as it's lived or experienced. Your alter ego goes forth into the world of demons and darkness, dragons and dwarves. Your character will do whatever you want him (or her or it) to do.

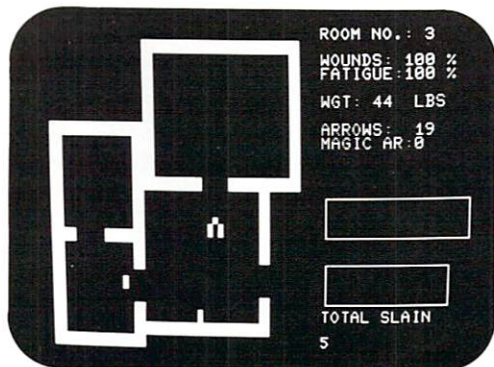

Actual photo of screen during a Dunjonquest game. In Room 3 in the Temple of Apschai, our hero observes two treasures unattended by dragons, monsters or demons... for the moment. He is completely free of wounds; he is not at all fatigued. He carries 44 pounds of armor and 19 arrows in his quiver. He has already slain five demons. Will he capture the treasures before moving on... or before the forces of darkness intercept him?

"The Temple..." comes complete with a superbly illustrated 56-page rule book and cassette program, designed to operate with the Level II 16K TRS 80, the PET 32K or the Apple II 48K (Applesoft) computer. Only \$24.95 complete, **including** shipping and handling on orders placed within the next 30 days. (Apple or TRS 80 disk available for \$29.95).

Dunjonquest's "The Temple of Apschai" is **guaranteed** to be the best version of Dungeons and Dragons/ Dragons and Dungeons. It's a product of the two guys who **are** Automated Simulations: Jim Connelley and Jon Freeman. Jim is a Dungeon Master, running continuous D & D campaigns. He's been a data processing professional with Westinghouse, GTE Sylvania, Logisticon... an expert in computer-based math-modeling and in simulation of complex phenomena. Jon is a game player, designer and author. He's a frequent contributor to *Games* magazine; his book, "The Playboy Winner's Guide to Board Games" is a paperback best-seller.

As we said, **guaranteed**: Guaranteed to be the best version; guaranteed that you'll be happy with it. Order now, use it for two weeks. If you don't enjoy completely this fantasy adventure experience that goes beyond all others, send it back to us. We'll refund your money in full; no questions asked.

Master Charge or Visa card holders: charge "The Temple of Apschai" to your credit card. Just call our toll free number: (800) 824-7888, operator 861 (In California, call operator 861 (800) 852-7777. In Hawaii and Alaska, operator 861 (800) 824-7919) and you can begin enjoying your Dunjonquest game in days. Or send your check for \$24.95* (or \$29.95)* to



**Automated
Simulations**

Dept. K
P.O. Box 4232
Mountain View,
CA 94040



*California residents, please add 6.5% tax.

D & R CASSETTE SYSTEM

Robert W. Baker,
15 Windsor Drive,
Atco, NJ 08004

Here's something that should be of interest to anyone considering adding another cassette drive to their PET system. D&R Creative Systems, PO Box 402B, St. Clair Shores, MI 48080 is now producing a cassette drive with a built in counter and several other features at a selling price that is less than the Commodore C2N cassette drive. The D&R S2545 Cassette System consists of a self contained, epoxy potted interface module and a Sanyo M2545A recorder. The recorder is specially modified to sense when the recorder buttons are pressed and operates identically to the PET cassette drive with full program control. The cassette recorder is still fully warranted by Sanyo, even with the slight modification.

The interface module plugs directly into the cassette port at the rear of any model PET and fits flat against the back panel. Because of the physical size of the interface module, it cannot be used with the cassette interface that is located inside the PET. There are four separate cables from the interface module which connect to the recorder REM, EAR, MIC, and added sense connectors. The sense connector is located inside the unused battery compartment which requires removing the battery compartment cover in order to make the connection.

Besides the digital counter for normal program indexing, the D&R Cassette system can locate programs audibly using the Fast Forward Cueing feature of the Sanyo recorder. While the recorder is in the Play mode, the Fast Forward button can be depressed and you can hear the programs pass by the recording head at the Fast Forward Cueing speed. It is very

easy to hear the 10 second leader at the start of each program and simply count the programs as they pass by to get to the desired program.

I recently tested a sample D&R Cassette system on an older 8K PET and a new 32K PET. I found no compatibility problems with tapes switched between the D&R Cassette system and three different Commodore C2N drives. D&R Creative systems does, however, warn of possible incompatibilities due to head alignments of the Commodore drives since Commodore has changed their cassette unit several times since the PET was introduced. Another point of interest is that the D&R Cassette system operates with the volume and tone controls of the Sanyo recorder all the way up and does not require any intermediate, special settings.

The only disadvantage of the D&R Cassette system is that the MIC and EAR cables cannot both be connected to the recorder at the same time. You must switch the cables to the Sanyo recorder whenever you switch between reading or writing a tape. This slight inconvenience seems a small price to pay when one considering the digital counter and Fast Forward Cueing features provided. Also, the Sanyo recorder can still be used as a standard recorder with a built in microphone and automatic level control for recording. Thus, the recorder could be used to take notes while working on a new program. All in all, the unit is very reliable and should be quite attractive considering the features provided at the current price of \$83 plus \$3 shipping. ©

DR. DALEY presents

Software for the PET and the APPLE

Dr. Daley's software is proud to announce the release of a package of our best selling programs.

These programs, regularly retailing for over \$400, have been assembled into a single

package for only \$69.95. Included is our best selling TREK3, CHECKBOOK, and a mailing list, tutorials, games and puzzles for every member of the family. All attractively packaged in an album.

50 PROGRAMS ONLY \$69.95*

Your order will be shipped within four business days from receipt.

Charge your order to
MC/VISA



* Disk version
\$10 extra.

DR. DALEY, 425 Grove Avenue, Berrien Springs, Michigan 49103

Phone (616) 471-5514 Sun. thru Thurs., noon to 9 p.m. eastern time.

Personal Computer Breakthrough

The Ohio Scientific Challenger 1 is a Dramatic Demonstration of Price and Performance in a Single Package

Announcing the microcomputer that scored a dramatic breakthrough in price and performance at a terrific system price!

Price/Performance Leader

The development of the Ohio Scientific Challenger 1P marked a price revolution for microcomputers. Consider the following features:

- (1) Microsoft 8K Basic-in-ROM
- (2) 4K RAM--Expandable to 8K on board
- (3) Full 53 Key keyboard with upper and lower case
- (4) Elaborate graphic display capability
- (5) Uses a standard cassette for input
- (6) Uses a standard television with an RF modulator for video output

All of these features makes the Challenger 1P a best buy for a beginner or hobbyist on a limited budget wishing to get involved with microcomputer, such as students & their educators, and various other professionals.

Already Looking Ahead??

Of course, we are not beginners forever (hopefully!!). What happens to the C1P then? Is it obsolete? That answer is a definite no!!

Consider the specification facts on the **expandability** of the Challenger 1P:

- (1) A fully expanded Challenger 1P can support:
 - (a) Basic-in-ROM
 - (b) 32K of RAM memory
 - (c) Dual Mini-floppies
 - (d) cassette
 - (e) printer
 - (f) modem
 - (g) full BUS expansion capability via the OSI 48 line BUS through which over 40 accessories can be added (A/D,D/A, voice output, I/O re memory, etc.)

As you can see, the Challenger 1P leaves more than adequate room for expansion. Thus, the system is not one you will have to 'get rid' of as you progress to more sophisticated computer functions.

Interested??

Here are the specifics for ordering the systems:

- (1) Freight and insurance are added to the cost of each package. Add \$6 for #1 and \$9 for #2 for delivery anywhere in the continental US. Overseas deliveries are available at a higher freight rate.
- (2) Funds transfers are handled easiest by money order or certified check, as this insures the quickest turnaround. Personal checks require 10-14 days to clear. Also, Visa & Mastercharge are accepted for your convenience.
- (3) All deliveries are made via UPS.
- (4) Warranty: A standard 60-day parts and labor warranty is in effect when purchased. After this period, parts are guaranteed for 1 year from purchase. Service work is done in-house whenever possible for a quick turnaround.
- (5) Want more information? Write for our OSI catalogs. Enclose \$2.00 for brochures & handling.

Challenger 1P with Disk Capabilities

If you are familiar enough with computers to realize the importance of disk storage, then the Challenger 1P Mini Floppy is a prime consideration.

At \$995, it is the first microcomputer system to offer disk storage capacity under \$1000, another breakthrough. The C1P MF offers the advantage of using either Basic-in-Rom or Pico-Dos, a compact DOS. The unit comes standard with 12K of RAM.

Additional memory can be added anytime by simply plugging in additional RAM into the socketed memory board. Upon adding 8K additional RAM to get to 20K, you may run OS65DV3.1, a full-fledged DOS allowing named program and data files as well as random and sequential access capabilities to these files.

Why System Packages?

Microcomputers are sophisticated devices that require more than the initial purchase. Once the purchase is made, a quick second, third, and even fourth trip is necessary to secure the accessories necessary to operate properly. To save you the additional trips, we have made two system packages available to the public at great savings.

System Package #1: Challenger 1P

- | | |
|----------------------------------|--------|
| (1) Challenger 1P w/4KRAM | 349.00 |
| (2) Additional 4K RAM(installed) | 69.00 |
| (3) Challenger 1P workbook | 7.00 |
| (4) Howard Sams schematics | 8.00 |
| (5) 3 Software tapes | 22.00 |
| (6) 10 blank data cassettes | 15.00 |
| Total List price | 470.00 |

CCSB System 1 Price 399.00

System Package #2: Challenger 1P MF

- | | |
|----------------------------------|---------|
| (1) Challenger 1P MF w/12K RAM | 995.00 |
| (2) Additional 8K RAM(installed) | 138.00 |
| (3) Challenger 1P workbook | 7.00 |
| (4) Howard Sams schematics | 8.00 |
| (5) OS65D V3.1 operating system | 50.00 |
| (6) 3 Software Tapes | 22.00 |
| (7) 10 blank diskettes | 35.00 |
| Total List Price | 1255.00 |

CCSB System 2 Price 1088.00

You will notice the system price reflects a **15% savings** over typical list price.

COMPUTER CENTER OF SOUTH BEND

51591 US 31 NORTH SOUTH BEND IN 46637 (219) 277-4655

Store Hours Mon-Saturday 12-8

Software for the PET

PROGRAMMA

Software Program Products



DOMINOES \$ 6.95

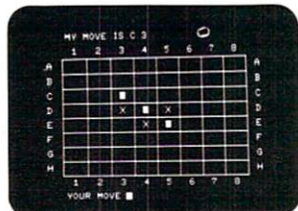

OTHELLO \$ 9.95



LETTER SQUARES \$ 6.95

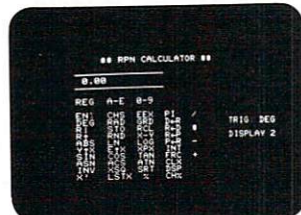

RPN MATHPACK \$19.95

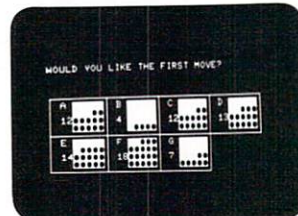

SUPER NIM \$ 6.95

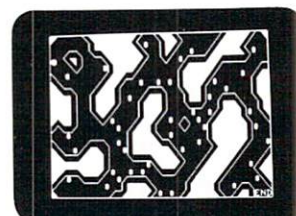

DIR/REF \$ 6.95

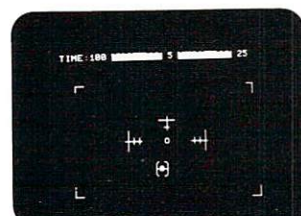

SPACE WARS \$ 9.95

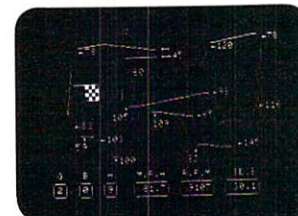

GRAND PRIX \$ 6.95

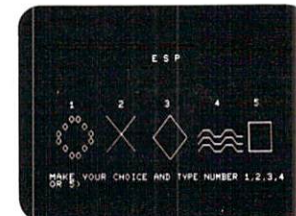

E.S.P. \$ 9.95

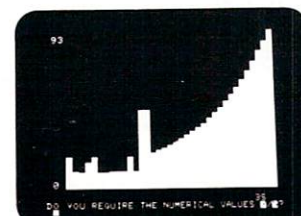

FORECAST \$ 9.95



\$ 6.95



BLOCKADE \$ 9.95

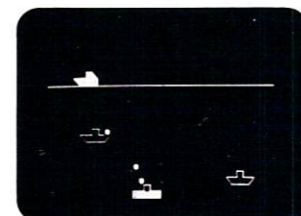

DEPTH CHARGE \$ 9.95

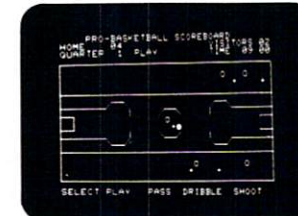

BASKETBALL \$ 9.95

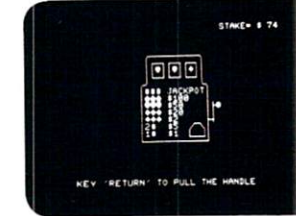

SLOT MACHINE \$ 6.95



HOME ACCOUNTING \$ 9.95

All orders include 3% postage and handling with a minimum of \$1.00. California residents include 6% Sales Tax.

VISA

MASTERCARD

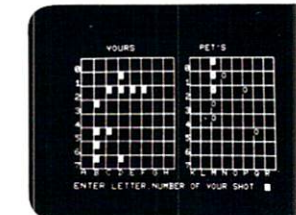

BATTLE SHIP \$ 9.95



SHOOTING GALLERY \$ 9.95

PROGRAMMA INTERNATIONAL, Inc.
3400 Wilshire Blvd.
Los Angeles, CA 90010
(213) 384-0579
384-1116
384-1117

Dealer Inquiries Invited



ZAP \$ 6.95

For your convenience in making use of the following article, I've reprinted a portion of Chuck Johnson's excellent article in *Best of the PET Gazette*, p.42. RCL

PET ting WITH A JOYSTICK

Harvey B. Herman
Chemistry Department
University of North Carolina
at Greensboro
Greensboro, N.C. 27412

My older style PET keyboard gets banged around quite a bit when my kids play games which use the number pad. A recent PET-Pourri column in Kilo-baud (1) prompted me to install a joystick on my PET in order to save my keytops from further wear. This article is intended to share my experiences with this project and to encourage other fumble-thumbs like myself to try it.

I purchased the Atari-joysticks from Sears as suggested in the above column (catalog #6C99835) for \$9.95 each. Since I could not find a mating connector, I cut off each end and attached them to a User Port connector as per the instructions (see also refs 2 and 3). The latter connector can be purchased from any number of companies (e.g., AB Computers). Four signal diodes (1N662), whose specifications I believe are not critical, are also used in this super simple interface circuit which can be constructed in about 1/2 hour. Check to make sure that the diode cathodes are connected as shown in the circuit diagram (1) and the color coded wires of the joystick are connected to the proper pins of the User Port connector. Otherwise no special precautions are necessary. I did it right the first time (yes brag!)

This neat hardware would, of course, be useless without software to work it. *Cursor* magazine (4) has supplied several programs which have a joystick option. I tried these first (Demon, Canyon, Pickup and Nab) with happy success. These programs are written to work with various model joysticks wired and oriented in different ways. Since my configuration was fixed I modified the joystick subroutine in each *Cursor* program to skip the test step. That procedure can be tedious if a program is run repeatedly. The following changes in the *Cursor* joystick subroutine should work for all Atari-type joysticks wired according to the circuit diagram in reference 1:

```
61030 PRINT: FOR I = 0 to 5: READ T, P:
      GOSUB 61120:
      T (I) = T: J(T) = P: NEXT I
61120 T = INT (T/16) AND T: RETURN
61250 DATA 255, 5, 223, 4, 239, 6 127, 8, 191, 2,
      63, 0.7, 1, 9, 3
```

I ran the original program once to find the values in the T array and used data statements in the modified program in order to skip the test step. This considerably speeds up the beginning of a game. I have deliberately ignored the rationale behind the bit manipulations in statement 61120. It is not necessary to understand that in order to use joysticks. I emphasize this point because I hope it will encourage PET users who may strain at bits to attempt projects such as described here. In a future article I may try my hand at a tutorial for those who wish to delve into this mystery further.

If a program was not written with a joystick in mind another modification procedure must be used to convert it away from number pad use. As an example I modified the program *Obstacle* (5) which utilizes the full keyboard as two pseudo-joysticks. Each player manipulates his piece (screen character) with the now standard keyboard patterns, "W, X, A and D" and "8, 2, 4, 6". The object is to keep from running into the screen trail left by the other player - the first to do so loses. As with many games it is easier to use than to describe. The following statements in the original program are used to sense a keypress by a player and change direction if necessary:

```
260 GET R$
265 IF R$ = "W" THEN AD = 1
      ●
      ●
      ●
300 IF R$ = "8" THEN BD = 1
      ●
      ●
      ●
```

If W is pressed the direction of the player on the left's piece is changed to up. If 8 is pressed the direction of the player on the right's piece is also changed to up. Player and direction are determined by the above keyboard pattern which can be learned quickly by new players.

Converting a program like this to joystick use is very easy. The following statements will do this:

```
260 M = PEEK (59471)
265 IF (M OR 240) = 247 THEN AD = 1
      ●
      ●
      ●
300 IF (M OR 15) = 127 THEN BD = 1
      ●
      ●
      ●
```

The elipsis can be fleshed out with the help of the table below. A peek at the User Port gives a unique value for each position of the joystick as long as only one is being used. It is necessary to "mask" with 15 or 240 if the possibility exists of both being used at the same time. If only one joystick is used and it doesn't matter which, a further opera-

tion with the peeked value generates simpler numbers (shown in the last column of the table). This "trick" was used in statement 61120 in the cursor subroutine and the resulting values used in the main body of the program.

In summary, I feel this is an excellent project for a beginner. The interface is quickly and easily put together. It is not difficult to modify existing programs for joystick use. "Old" PET owners with disappearing keytops will appreciate the saving on wear and tear. To be fair I should say that every program is not suitable for conversion. When fine control of movement is required joysticks may be difficult to use. Some players with poor hand-eye coordination may still prefer the keyboard. As for me it seems quite natural to chase and catch some seemingly elusive demon with my movements under reflex control by a joystick.

REFERENCES

1. *Kilobaud Microcomputing*, Robert W. Baker, January 1980, p.14
2. *PET User's Group Newsletter*, Vol. 0, No. 3, p.6, 1978
3. *Best of PET Gazette*, Chuck Johnston, p.42, 1979
4. *Cursor Magazine*, P.O. Box 550, Goleta, CA 93017
5. *Dilithium Press*, P.O. Box 92, Forest Grove, OR 97116

TABLE

T = PEEK (59471)

POSITION	Joystick 1	Joystick 2	T = INT (T/16) AND T
center	255	255	15
left	223	253	13
right	239	254	14
up	127	247	7
down	191	251	11
button	63	243	3
left up	95	245	5
right up	111	246	6
left down	159	249	9
right down	175	250	10
mask	T OR 15	T OR 240	

©

From: PET AND THE DUAL JOYSTICKS

Chuck Johnson

JOYSTICK ATTACHMENT STANDARD

The Atari Joystick terminates with a DB-9 connector; six of the nine circuits are used as follows:

	DB-9PIN	FUNCTION
	1	Up Switch
	2	Down Switch
5 4 3 2 1	3	Left Switch
.....	4	Right Switch
	5	Not Used
.....	6	Push-Button Switch
9 8 7 6	7	Not Used
	8	Ground (common)
	9	Not Used

Pin numbers for the DB-25P are marked on the connector. User Port pins are on the bottom row of a 12 position edge connector. Proper polarization of the edge connector is strongly recommended.

Note that the buttons are wired through diodes to both the UP and DOWN functions of their joysticks (pins E and F and pins K & L). When a button is pressed, the PET data lines react as though the joysticks were pushed up and down simultaneously (an impossible condition for the position switches to generate). The decoding standard will, as we shall see, interpret this condition as a button movement. The diodes act as "one-way streets" for current flow and prevent the real UP and DOWN switches from closing both circuits.

Orientation of the diodes is very important. We want current to flow from the data lines to ground. When soldering the diodes in place, orient them with their cathodes ("banded" ends) connected to the joystick buttons (pins 14 and 22 on the DB-25P). If the user is not interested in using the buttons, the button lines may be left unconnected and the diodes omitted.

A DB-25P connector will accept two joystick connectors; the DB-25 may then be wired to a User Port edge connector, according to the following table:

JOYSTICK	DB-9S PIN	DB-25P PIN	USER PORT PIN	USER PORT FUNCTION
1. UP	1	9	F	PA3
DOWN	2	10	E	PA2
LEFT	3	11	D	PA1
RIGHT	4	12	C	PA0
BUTTON	6	22	Diodes to E and F	PA2 and PA3
GROUND	8	24	A	GROUND
2. UP	1	1	L	PA7
DOWN	2	2	K	PA6
LEFT	3	3	J	PA5
RIGHT	4	4	H	PA4
BUTTON	6	14	Diodes to K and L	PA6 and PA7
GROUND	8	16	N	GROUND

©

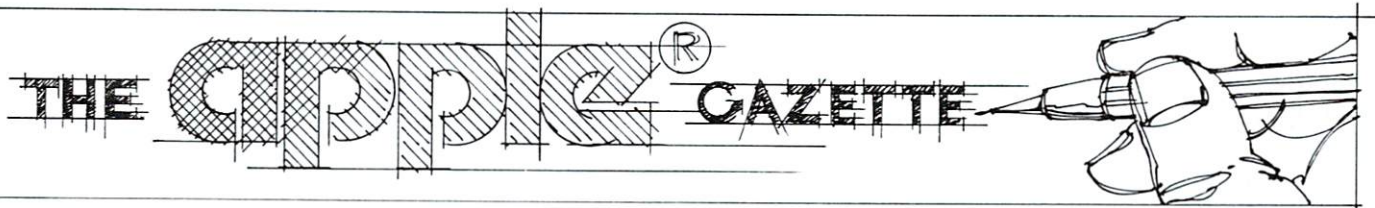

APPLETIVITES AT THE WEST COAST COMPUTER FAIRE

Joe Budge
2507 Elderwood Lane
Burlington, N.C. 27215

The West Coast Computer Faire, held March 14-16 this year, was the focal point for many Apple Computer developments. Several companies introduced significant new software and hardware. These new introductions should greatly enhance the Apple's capabilities. User groups from all over the world convened at the Faire to start an international user's group. The group then sponsored a full day of seminars on the Apple, with subjects ranging from the Apple's invention to its application in music and foreign language instruction.

On March 13 representatives of 60 member clubs met in San Francisco to formally initiate the International Apple Core. Directors were elected, lengthy discussions were held, and policies were worked out. Directors and officers met for the following two days arranging quite a few important details.

The International Apple Core (IAC) will be a non-profit organization dedicated to the exchange of information among Apple Computer users. This will be broadly interpreted to include technical information, software, programming information, and anything else which can benefit Apple users throughout the world. In addition the IAC will provide for communications between members and the various product manufacturers. The International Apple Core will not be affiliated with Apple Computer or any other manufacturer. Specific areas of IAC activity will include publication of the "Orchard", maintenance of a public-domain software library, support of special interest groups, support of software and hardware standards, technical support, promulgation of ethics, and organization of annual Apple - faires.

The IAC does not intend to have individual memberships. Only non-profit Apple user groups may be members. Educational institutions and other interested non-profit organizations may become associate members. They will be entitled to all the free printed information the IAC provides its members, but can not vote for directors. Commercial enterprises may become sponsors, entitled to information and participation in standards establishment. They, too, would be non-voting, but would receive preferential

advertising treatment in IAC publications. Dues for members and sponsors will be \$50 and \$200, respectively. They will be collected every January First. Associate members pay no dues.

The "Apple Orchard" will be the IAC's official magazine. It will be published quarterly, starting September First. The "Apple Orchard" will replace future editions of "Contact." "Contact" had been sent by Apple Computer to all registered users. Unlike "Contact," the "Orchard" will be available either by subscription or by sale through clubs or stores. Apple Computer Company intends to purchase some "Orchards" from the IAC. One copy will be sent to each newly - registered Apple owner to tell them about user groups.

A number of committees and special interest groups were established to deal with specific subjects. The IAC will try to establish a hot-line for technical and software problems. Until permanent arrangements can be made, Apple owners will have to continue using current lines provided by various clubs and Apple Computer, Inc. Neil Lipson's software committee will be collecting, documenting, and distributing a diskette a month to the member clubs. These will contain public domain software and will be distributed free of charge. The IAC will also distribute to members application notes from Apple Computer and other suppliers. Special interest support includes educational and legal application groups, a handicapped usage group, and a ham radio net. Anyone wishing to contact the International Apple Core may write them at P.O. Box 976, Daly City, Ca. 94017.

The International Apple Core sponsored a series of Apple seminars during the second day of the Faire. The subjects covered a variety of fronts, from the workings of graphics and the disk operating system to applications of different languages such as Forth and Pascal. The most interest was shown in a pair of lectures by Steve Jobs and Steve Wozniak, the inventors of the Apple. They told how the Apple started as a video terminal used to play games on telecommunications networks. Being members of the Homebrew Computer Club, they became interested

in microprocessors. With that, Jobs and Wozniak started to add processing and memory to the video terminal, added a hand - assembled Basic interpreter, and so on. Before they knew it, they had a microcomputer on their hands. The new machine was so popular at the meetings that Jobs and Wozniak decided to print up a circuit board. That way their friends could build the new micro too, while they were freed from supervising everyone's assembly and debugging. To recoup costs the two began selling computer boards with a set of instructions and a parts list. That worked fine for a few months. Then one store owner decided to take 50 boards, but only pre-assembled and tested. Thus was born Apple Computer Company.

Apple Computer has, obviously, grown considerably from those meagre beginnings in 1975. Upon realizing the advantage of the single-board computer over the buss machines, Apple made a few improvements to smooth out the rough edges. They added I/O decoding to the peripheral slots, a cassette interface, dynamic RAM, and better video. This created the Apple II. The Apple II has been so successful and so versatile that Apple has determined not to obsolete it. New equipment will allow Apple to easily specialize in certain areas. For example rumors abound of a new business machine similar to Radio Shack's Model II, as well as of a new Pascal teaching machine. Whether these rumors are true remains anyone's guess. Nevertheless Apple is trying to solve the problem of making a computer that is at once sophisticated and yet doesn't require high intelligence to operate.

Many fascinating new products introduced at the Faire demonstrate the Apple II's potential and versatility. The show - stopper was Microsoft's new Z-80 board. This board, which plugs into one of the Apple's peripheral slots, can supress the 6502 microprocessor and turn on its own Z-80. It uses the regular Apple memory and I/O devices. Priced at \$350, the board comes complete with two diskettes containing CP/M and Advanced Microsoft Basic. Production and distribution should start in May. Fortran, Cobol, and other advanced languages should become available for the Z-80 card during the summer. On the applications side of the fence an equally significant development was Programma International's unveiling of a general accounting package. Priced around \$200, it appears every bit as capable as IBM's package for the 5110. IBM's software sells at 10 times the price. Three manufacturers introduced eighty - column video boards for the Apple's text display. These are for tele-communications, word processing, and use with the Pascal editor. The boards were priced from \$200 to \$400, and should be available in most retail outlets at press time. With all these new developments, the next year looks to be extremely interesting for Apple users everywhere.

Computer House Div.

Announces

Programs for Apple

"Legal Accounting"	\$1200.00
"Retail Accounts Receivable"	400.00
"Political Party Mailing List"	150.00

Programing Tools For the Commodore/Disk

"SOF-BKUP" — \$40.00

Faster & Error Free Disk Copy

"FET/RECOVER" — \$65.00

File Editing Tool; Examine Data Files, Fix Destroyed Pointers, Sectors may be Read, Modified, Displayed or Written — Also Files may be Re-chained

"SUPER RAM" — \$20.00

Diagnostic Routine Checks Every Possible RAM Address on 8K, 16K & 32K Commodore Computers

Available on Diskette right now.....

All 3 above only \$105.00 retail

ENGINEERING & MACHINE SHOP

Programs for Commodore System

"Machine Part Quoting"	\$280.00
"Trig & Circle Tangent"	70.00
"Bolt Circle"	25.00
"Spur Gears"	35.00
"Beams; Stress & Deflection"	145.00
"Tank Thickness" For Filament Winding	85.00

All 6 for only \$495.00

And many others coming soon — including RPG for Commodore — Ask for Catalog #80-C2.

COMPUTER HOUSE DIV.

1407 Clinton Road
Jackson, Michigan 49202
Phone: (517) 782-2132

The APPLE PI Trading Library

Terry N. Taylor
Club Librarian

We have well over 3500 public domain programs on 148 disc sides in our Apple PI library. Copies of our November catalogue (showing 2780 programs) are still available for \$1 plus 50 cents postage from our newsletter editor:

Rodney Nelsen
9711 Josephine St.
Thornton, CO 80229 Ph. (303) 451-7577

Later arrivals are shown in our monthly newsletters, available at \$1.00 each.

While most of the approximately 800 plus programs on our Apple PI slices #1 to 20 and 178 to 200 are either original efforts by our members (both local and out-of-state) or have been modified for the Apple II from a magazine listing, there are probably a few donations that originally came from other sources. Copyrighted programs are not supposed to be in our trading library out of respect to the commercial copyright holders. So if a copyrighted version of a program appears in error, please let us know so that it can be removed. Also, since many of our members belong to several Apple user groups, if they have accidentally donated someone else's program that they did not have permission to donate to our group; and we listed it unknowingly, we are sorry again. Please inform us. The approximately 2400 programs that we have received in trade from 21 other Apple user groups are listed on our Apple PI slices #21 to 126.

Our programs were originally cataloged on a 32K Apple without the Applesoft ROM card. All of the programs on our disc slices (i.e. from 1 to 20 and 179 to 200) should have been converted to the A.S. ROM card and should now work on a 48K Apple. (In fact, some programs require 48K to operate.) To convert an Applesoft program for non-ROM use; load the program, call 3314. Then either save it or run it. To convert a program from a non-ROM card source to ROM, call 54514. This is not needed if you have either DOS 3. 2. or 3.2.1.

The Hello programs on our disc sides (i.e., Apple PI slice XXX (YYYYYYYY)) identify the type of programs on the disc (i.e. the word 'Games', 'Finance', 'Utilities', etc. will appear where the Y's are shown in brackets). The Hello program on the disk slices that we have received from other clubs is formatted the same way, except the club name or location is shown in place of the Y's when the Hello program is booted. Their name is also shown on the screen so that the donating groups receive credit for their programs.

If you have a bombout, or see possible improvements, please either note the circumstances (including the configuration of your computer) of the bombout on a card to us so that we can fix the program if

needed--or improve it yourself and resubmit it as your donation. Either way, someone else will then not have to wrestle with the same bugs you did. The reason we need your configuration is that not all programs will run on every Apple (you might not have a needed accessory). As a side note, if the hires page from a previous program is still on, then (1) press CTRL-C to stop the program, (2) Poke -16298,0 to turn off the hires page, and (3) type run to start the program again. That should fix that problem. All lores Graphic programs should automatically turn off the hires page as one of their first statements. But some don't.

TO TRADE (FINALLY!!!)

FOR NON-LOCAL MEMBERS. Other Apple user groups, or individuals who just want to trade. Please either send your discs or cassettes of programs to me:

Terry N. Taylor
12319 E. Bates Circle
Aurora, Colo 80014 Ph. (303) 750-5813

I will copy your programs and return your choice of our slices on your discs and mail them right back to you. If you are a brand-new Apple user group, we will trade you two sides for one to help you get started, or even advance some programs on the understanding that you will later send some of your own programs back to us. Fair enough?

When you donate programs, please take a minute to jot down on a 3 by 5 card the following:

- 1) Name of the program (exactly as it will be on the disk).
- 2) What language the program is in.
- 3) What type of program it is (i.e., Music, Finance, Game, Hires, Etc.)
- 4) Author's name and, if different, who actually listed the program into the Apple.
- 5) Source of program (i.e., original program, or the Title, Page, and Issue # of the magazine copied from)
- 6) Length of program (if known) Also the starting address if it is a Binary program.
- 7) Whether the program calls up any other programs, and, if so, their names
- 8) What accessories, if any, are needed. (i.e., programmers aid, 48K, type of printer, disc or cassette based, etc.)
- 9) Finally, a short description (say 25 words or so) of what the program does.

If you don't know one of the areas, just leave it blank. Unfortunately, with over 3000 programs, not too many people can remember exactly what each program does just by looking at the title; so any help here is deeply appreciated. Still, don't let it stop you from donating your program if you feel it is a hindrance. It won't be the only one that needs some documentation.

Thanks for reading this far and happy programming.



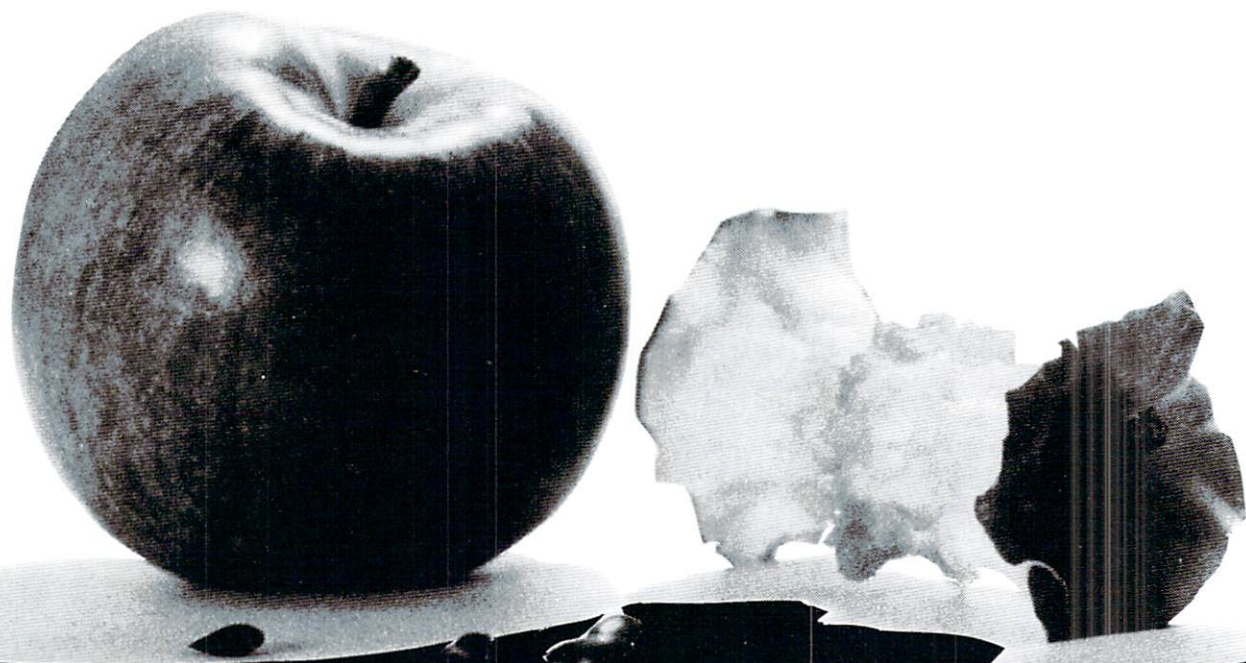

Introducing AppleSeed, our newest publication to whet your Apple* appetite!

We invite you to subscribe to AppleSeed - the magazine that is to the Apple II* what SoftSide is to the TRS-80**. It offers the newest in software programming hints and ideas tailored especially for your computer. AppleSeed features challenging programs for both the do-it-yourselfer and the individual interested in pre-packaged programs and games . . . your own preview of the best available on the market today. A typical slice of AppleSeed consists of one major (new 16K) commercial level program (completely listed for your keying pleasure), accompanied by two or three applications for practical use or fun, supplemented by informative articles to polish your Apple*. Get right to the core of your Apple* needs and order AppleSeed today! 12 issues, 1 year, \$15.00. AppleSeed is the newest member of . . .

SoftSide™

PUBLICATIONS

6 South Street, Millford, NH 03055
(603) 673-5144

Editor's Note: In future issues, we'll present interviews with Marketing personnel from Atari and Commodore.

An Interview With Taylor Pohlman Apple's Product Marketing Manager

Michael
S. Tomczyk

Recently, I had an opportunity to talk with Taylor Pohlman, Apple Computer's Product Marketing Manager. Taylor is 33 years old and came to Apple less than a year ago from Hewlett Packard, where he was educational marketing manager. During our interview, he discussed two important areas -- computer dealers and consumers.

He described two basic types of dealers, noting that dealers are first of all businessmen and secondly, tend to operate in those markets they are most comfortable or experienced in.

The first type of dealer is the *hobbyist who becomes a businessman*. For these dealers, technology is the key. Since the first-round hobbyist market is pretty much saturated, Pohlman feels these dealers have to start moving from hardware -- their original orientation -- to software, and the application problems of non-hobbyist users.

The second type of dealer is the *retail businessman*. To them, selling computers is much like selling hi-fi stereo systems. A fair amount of retail audio-visual and electronics outlets are personal computer dealers, he said, and many have already developed the expertise needed to reach the computer market. A-V stores may already be dealing with schools, for example, and the educational market is a natural for them. Small stores also relate well to small businessmen because the dealers, as businessmen, have themselves encountered problems in general ledger keeping, manufacturing, accounting, etc.

"The personal computer market is emphasizing solution-oriented merchandizing as opposed to hardware-oriented merchandizing," Pohlman said, and this poses important challenges for all types of computer dealers. He said Apple has 600 to 700 computer dealers, all with different interests, sales and facilities. Some sell a single line and others a complete line, from small games to minicomputers.

"The question they all have to ask is, who are those hungry people outside the store who have problems to be solved by a personal computer? At Apple, we try to turn the dealers on to those markets --

and solutions -- whatever the dealer's 'focus'. By 'focus' I mean hobbyist, businessman, educator, home entertainment user. . . .but whatever its focus, a good Apple store doesn't confuse the customer.

"For example, the businessman doesn't want to know this microprocessor runs 20 percent faster than that one. He wants to know will it solve his problem? On the other hand, the store that just has a bunch of hardware sitting around may respond well to the hobbyist by making the hardware available on the floor and letting him look inside." (Incidentally, Taylor Pohlman's definition of a computer hobbyist is, "the individual who's interested in the man-machine interface.")

He kept emphasizing that the key to the overall personal computer market is problem-solving. In this regard, Apple's magazines and other literature are designed to trigger people's problem-solving approaches and stimulate their imagination. He also called attention to the company's seminar program, which encourages dealers to get out and give seminars where the people are -- at Rotary Clubs or real estate groups, for example. Apple provides instructional and advertising materials to dealers for this purpose.

"For the dealer to survive in the new marketplace, he's also going to have to provide service and support -- not just sales," he said. Consequently, Apple has a modular design and can be field-repaired at over 500 dealer-based repair centers, in 24 hours. If the dealer can't repair it, he can simply replace the failed part and send it to Apple for repair. This is especially important to the businessman, who can't afford to have his general ledger or other system go down for a week.

Turning his attention to consumers, he guessed that there are "tens of thousands" of Apples in homes, schools, and companies. "We're the one personal computer vendor that has achieved a truly disk-based population -- as opposed to those who are still out there hyping cassettes. Disk-based software is more sophisticated and makes the Apple more useful and powerful as a problem-solving tool.

"What I, as a consumer, want is a computer that allows me to define a problem and allows the machine to solve it in language and terms that I can understand. If the problem is solved I could care less what the machine is doing." He added that the level of computer awareness is very high but the level of computer *literacy* is not nearly high enough to create the "home computer revolution," mostly because right now using a computer means you have to:

- define a problem
- create an algorithm to solve the problem
- write programs to express the algorithm
- put the program in the computer
- run and debug the program

"A lot of time is wasted trying to *translate* information, and this wasted time is directly related to the reluctance -- or lack of reluctance -- of customers to get

involved with a personal computer," he said. He went on to say that the home computer revolution will not truly arrive until you can more effectively separate the user from the intricacies of hardware and software, so he doesn't have to understand the inside of the machine or the inside of the software in order to use it.

He also spoke of a "vast dumping ground" where a lot of people who buy computers encounter so many stumbling blocks to using them (language, interface, hardware) that they wind up juking them, and said Apple is working hard to solve this and other problems not only through product development and dealer support, but also by encouraging such vocal forums as the International Apple Core.

He concluded by saying that he doesn't think Apple II is a mature product after two years and indicated that future Apples will maintain compatibility, as opposed to some companies which have come out with new machines which weren't compatible with earlier versions. He said, "If people think Apple is going to somehow change it's product or it's way of doing business, they're wrong."

©

6502 MACRO ASSEMBLER AND TEXT EDITOR

- Versions for PET, APPLE II, SYM, KIM and ATARI I (1st quarter 1980)
- Written entirely in **machine language**
- Occupies 8K of memory starting at \$2000 — Apple version with disk occupies just over 9K
- **Macro** and conditional assembly
- 36 error codes, 26 commands, 22 pseudo ops
- Labels up to 10 characters
- Auto line numbering and renumber command
- String search and string search and replace
- Copy, move, delete, load, save, and append commands

Cassette and Manual \$49.95
(including U. S. postage)

Eastern House Software

3239 Linda Dr.

Winston-Salem, N. C. 27106

GIVE YOUR APPLE A BYTE OF THIS...

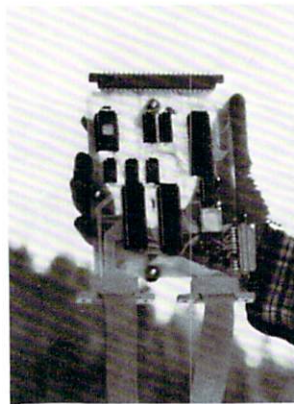

GPA ELECTRONICS'
Programmable,
Intelligent I/O.
More than a
telecommunications
I/O. More than an
intelligent hard copy
interface. GPA's
Intelligent I/O is a
COMPLETE
MICROCOMPUTER
on a 4 1/2 "x7" card!

Completely programmable via Resident Monitor in PROM, the Intelligent I/O lets you select the operation you desire, then helps you complete the task.

FEATURES:

- ★ 6502 Microprocessor.
- ★ 2K E-PROM; 1K RAM as buffer.
- ★ Serial and parallel I/O through four ports. Device can communicate with two peripherals simultaneously; RS-232 devices can communicate with parallel devices.
- ★ Hard copy interfacing with either RS-232 or 20mA devices (Please specify.)
- ★ Accommodates all baud rates to 9600.
- ★ Selectable line feed, carriage return delay and characters per line.
- ★ Supports standard EIA modem-control signals.
- ★ Handshaking, of course.
- ★ Functions as Data Channel, SPOOLER or Programmable Filter.
- ★ Remote access to Basic.
- ★ Fully disk compatible.
- ★ Will provide secure, encrypted telecommunications with optional programming.
- ★ Complete dial-up and time sharing functions.
- ★ Allows ganging of microcomputers for multiprocessing.
- ★ Accesses and controls servos, sensors, articulated devices or transducers (with appropriate firmware, available from GPA.)
- ★ Functions as disk controller, resident assembler, E-PROM burner (with optional firmware.)
- ★ Integral power supply (5VDC @ 350mA.) Completely portable, stand-alone computer.
- ★ Fully documented, tested and guaranteed.

See your dealer today, or order direct from GPA.

Just \$299.95 (110VAC) or \$320.95 (250VAC)



* Apple is a registered trade mark of Apple Computer, Inc.

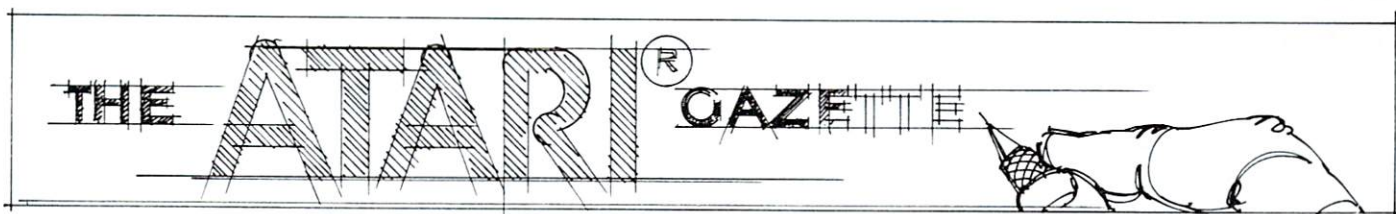

MADE IN THE SHADE: AN INTRODUCTION TO "THREE- DIMENSIONAL" GRAPHICS ON THE ATARI COMPUTERS

David D. Thornburg
Innovation
P.O. Box 1317, Los Altos, CA 94022

If you know anything at all about the Atari 400 and 800, you probably know that these machines give you access to 256 colors. What you may *not* realize is that these colors are specified with two independent parameters which allow you to create "three-dimensional" objects on the display.

The two parameters of interest are *hue* and *luminosity*. Atari gives you access to sixteen colors (the hues), each of which can be darkened or lightened by setting the luminance to one of eight levels. Traditionally, computers that offer limited colors (sixteen total, for example) pre-select different hues *and* luminosities for each color so that inter-color contrast is always apparent, even when the picture is shown on a black and white display. If two colors have the same luminosity, you will not see any difference between the colors when they are shown on a black and white display - a phenomenon you should demonstrate to yourself sometime.

The beauty of the Atari scheme is that the wide range of available colors leads to the ability to create some pretty pictures, even though only four colors can be displayed at one time. The program presented here illustrates a common graphics task - the representation of a solid three-dimensional object through shading.

Since we can display three colors plus the background in a moderate resolution graphics mode, this lets us represent a shaded cube. After all, you can only see a maximum of three faces of a cube at any given time. The function of the program, then, is to create a two-dimensional representation of a cube in which the "realism" results from the control of the shading on each visible face.

In case you are not familiar with Atari graphics, a short digression is in order. Displayed colors are established by the **SETCOLOR** command which takes the form **SETCOLOR A, B, C** in which **A** is the color register (0-4), **B** is the hue (0-15) and **C** is the luminosity (an even number from 0 to 14). (I don't know why luminosity isn't set with numbers

between 0 and 7, but the use of even numbers doesn't present too much of a problem, as you will see.) The hues (see Table I) are the various basic colors you can use to draw your pictures, and the luminosities control the brightness from 0 (very dark) to 14 (almost white). Once you have set the color registers, you need to indicate which register should be used for the various plotting commands. This function is performed with the **COLOR** statement. This statement has the form **COLOR D** in which **D** refers to the color register in which the desired color is located. Now for reasons that I don't understand, the value of **D** is generally larger than the color register number by one. In other words, $D = A + 1$.

PROGRAM LISTING

```
10 REM ** SHADING DEMO
20 GRAPHICS 23
30 OPEN #1,4,0,"K:"
40 FOR I=0 TO 4: SETCOLOR I,9,4 : NEXT I
50 X0 = 48 : Y0 = 36
60 COLOR 1
70 FOR I=0 TO 40
80 PLOT X0,Y0 + I : DRAWTO X0 + 40,Y0 + I
90 NEXT I
100 COLOR 2
110 FOR I=1 TO 24
120 PLOT X0 + I,Y0-I : DRAWTO X0 + I + 40,Y0-I
130 NEXT I
140 COLOR 3
150 FOR I=1 TO 24
160 PLOT X0 + 40 + I,Y0-I : DRAWTO X0 + 40 + I,
170 NEXT I                                     Y0 + 40-I
180 FOR I=0 TO 2
190 GET #1,A
200 IF A<48 THEN A = 48
210 SETCOLOR I,1,2*(A-48)
220 NEXT I
230 GOTO 180
```

Now that these tips on Atari color are under your belt, it is time to try out the program.

The listing starts out by setting a moderately high resolution full-frame graphics mode in statement 20. This mode allows the display of four colors and contains 160 x 96 picture elements - plenty for our need. The **OPEN** statement lets us use a **GET** statement to receive data from the keyboard without having to press **RETURN**. Note that the Atari version of **GET** is very different from the version you may be accustomed to from Microsoft BASIC. Next, the color registers are all set at the same color value so that when the cube is first drawn you cannot see it. The front face of the cube is drawn in **COLOR 1** (from **SETCOLOR** register 0) in lines 70-90, and the other two faces are drawn in **COLOR 2** and **COLOR 3** in lines 110-130 and 150-170 respectively. At this point the computer waits in line 190 until a key is typed. (Note that in Microsoft BASIC the program would not stay at a **GET** command, but would look once and be on its way.) Since I expect to be **GET**-ting a keystroke from keys 0 through 7 (which have the Atari-ASCII values 48 through 55), lines 200 and 210 convert the keystroke to an even number between 0 and 14 for use in the **SETCOLOR** command. This program looks for three keystrokes - one for each face of the cube. As each key is typed (try 5, 6 and 7, for example) a cube face will become visible. The result is that a "three-dimensional" representation of a cube is now nicely displayed on your TV screen.

If you want to change the shadings, type three more numbers between 0 and 7 and see what happens. Next, for some more excitement, type J, K and L. Once again you will see the shaded cube, but the color will have changed from gold to more of a magenta. As you can see, luminance values greater than 14 cause the hue to change.

Now that you know about shading, you should be able to make some truly beautiful pictures on the Atari computers!

Table 1. Hue Values For The Atari Computers

COLOR	HUE VALUE
GRAY	0
LIGHT ORANGE	1
ORANGE	2
RED-ORANGE	3
PINK	4
PURPLE	5
PURPLE-BLUE	6
BLUE	7
ANOTHER BLUE	8
LIGHT BLUE	9
TURQUOISE	10
GREEN-BLUE	11
GREEN	12
YELLOW-GREEN	13
ORANGE-GREEN	14
LIGHT ORANGE	15

©

INTRODUCING FOR THE ATARI™

GUESSWORD — Based on the TV show Password, the computer gives clues to the 'secret' word. The faster you guess the word, the higher your score. For one or two players (grades 6+) cass. \$15.00

FISHING FOR HOMONYMS — Play the popular game of Fish with the computer. This time ask for the homonyms to the word-cards that appear in your hand. (grades 3-6) cass \$15.00

WANTED — Be a detective and track down the words that have escaped your vocabulary. Clues appear on the screen in the form of a 'Wanted' poster. (grades 4-8) cass \$15.00

WORD-MATE — Build compound words with the words that have been dealt to you. Try to make more compound words than the computer. Don't get stuck with the last card (grades 3-6) cass \$15.00

WORD-SCRAMBLE — Unscramble the words that appear on the screen. Five different levels to choose from. Contains the most frequently used words in Primary Readers. (grades 1-4) cass \$15.00

COMING SOON . . .
PRESCHOOL FUN
MATH FACTS I
CRIBBAGE

R.H.E.S.I.S
P.O. Box 147
Garden City, MI 48135

Write for Free Flyer
**DEALER ORDERS
WELCOME**

Or Call: (313) 595-4722

ATARI 800 3-DIMENSIONAL GRAPHICS

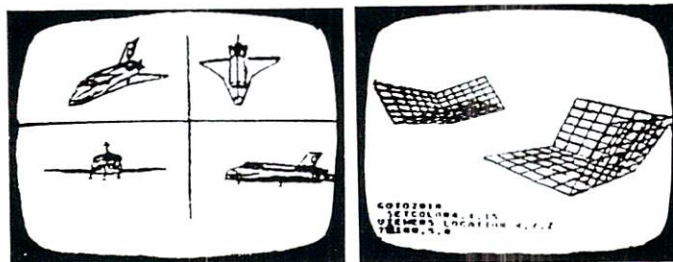

Imagine, being able to put in memory any 3-D object, and view it from any location and degree of rotation, underneath, inside of! This is a set of 4 programs W/listings that will run in 8K! 16K min. for HI RES. Programmed in Basic but executes very fast, and program is easy to expand. Multiple color control, software selectable resolution, Multiple color control, software selectable resolution, line clipping & pushing, telephoto/wide angle, etc. Manual covers given examples for user-input of scenes.
\$29.95 + 1.50 P&H

WUMPUS ADVENTURE

Combined Super Wumpus & Adventure with color graphics, sound, and more player interaction than any other Wumpus-type game available. User can control the way his arrows fly graphically, and use strategy in running away from the Wumpus.
16K W/instruction manual
\$14.95 + 1.50 P&H

SEBREE'S COMPUTING

456 Granite Ave.
Monrovia, Ca 91016

We also carry a complete line of BALLY ARCADE software.

Atari Tape Data Files

A Consumer Oriented Approach

Al Baker
2327 S. Westminster
Wheaton, IL 60187

Introduction

This article is based on a major axiom of consumer computing:

Easier is Better

The specific corollary when writing a program which saves data between program runs is:

Use only one tape. Program and data should be on the same tape. They should, in fact, be the same thing.

A consumer should be able to load his program, run it to update his checkbook and balance his budget, and then save the program on tape when done. The next day, he can load his program and all data changes from the previous day should be there.

"Impossible", you say? Well, perhaps. It is certainly impossible on some of the computers on the market. But it is not impossible on the Atari. The trick is to fool Atari Basic into saving all dimensioned variables when a program is saved to tape. We won't try to save the simple variables. Since I am not a revered expert, I won't make the mistake of saying this is impossible. (But, I think it's impossible.) Saving the dimensioned variables with a program is relatively easy.

Write your program

Listing 1 is a simple program. Nothing tricky. But notice that I print the dimensioned variables in Lines 70-130 and then assign values to them in Lines 140-190. I am assuming the variables have valid contents before changing them! The only important restriction here is to type the line containing the DIM statement first. It doesn't have to be the first line in the program. Just make sure it is the first line typed.

The Atari Basic variable symbol table is constructed when each line is typed in, not when the program is run. Later we will need to find the locations of the string variables in the table. This is easier if they are the first variables present. For a more complete discussion of the symbol table, see the text in the box.

```
50 DIM A$(10),B(2,3)
70 ? A$
80 FOR I=0 TO 2
90 FOR J=0 TO 3
100 PRINT B(I,J),
110 NEXT J
120 PRINT
130 NEXT I
140 ? "STRING=";:INPUT A$
150 ? "I=";:INPUT I
160 IF I=9 THEN 200
170 ? "J=";:INPUT A:B(I,J)=A
190 GOTO 150
200 END
```

Suppose the program is already written and you didn't type the DIM statement first. Write your program to tape using the command LIST"C". Type NEW. Now type the DIM statement from your program with the string variables first. Finally, reload the program from tape with the command ENTER "C". Now the string variables are at the beginning of the variable tables.

Protect the Dimensioned Variables

The next step is to fool Basic into treating the dimensioned variables as part of the program. Also, you have to add the code to let the program save itself to tape. In an application, saving the program to tape will be the final program option selected by the user. In Listing 2 this is added to the program in lines 200 through 230.

```
50 DIM A$(10),B(2,3)
70 ? A$
80 FOR I=0 TO 2
90 FOR J=0 TO 3
100 PRINT B(I,J),
110 NEXT J
120 PRINT
130 NEXT I
140 ? "STRING=";:INPUT A$
150 ? "I=";:INPUT I
160 IF I=9 THEN 200
170 ? "J=";:INPUT A:B(I,J)=A
190 GOTO 150
200 A=PEEK(140)+PEEK(141)*256
210 A=A+82
220 POKE 141,INT(A/256):POKE 140,A-PEEK(141)*256
230 CSAVE
```

Locations 140 and 141 contain the address of the end of the computer program. Program line 200 places this address in the variable A. In line 210 we add the size of the dimensioned variables. Each string variable contains as many bytes as its dimension. Each numeric array contains 6 times the number of members of the array. The B array is $6 \times (2 + 1) \times (3 + 1) = 6 \times 3 \times 4 = 72$ bytes. Thus we had to add $10 + 72$ or 82 to the end of the program in the example.

Now run the program and let the internal CSAVE create a tape. Turn the computer off and then on. Now reload the newly created program from tape. For some reason this step is important. (I don't know why.) If you do not use the new tape, this procedure won't work.

Finish the program

We now have a program in memory which has an invalid program - end pointer. See the third listing. Add lines 10 through 40 to your program. Make sure that you use the correct number instead of "-82"

in line 10. Remember that this number is the size of your dimensioned variables.

Refer to Table 1. Locations 140 and 141 form the program-end address. Locations 142 and 143 form the stack address and locations 144 and 145 form the pointer to the end of memory used by the program. The RUN command sets all of them equal to the incorrect end-of-program pointer. Lines 10 through 40 correct them.

Here comes the only hard part. You are going to have to peek around in memory. The RUN command sets the length of all strings to zero. You must repair their lengths if you want to save string data.

Table 1.

These two byte addresses point to important areas used by Atari Basic.

Use this	To get the location of this
PEEK(130) + PEEK(131)*256	Variable name table
PEEK(134) + PEEK(135)*256	Variable value table
PEEK(136) + PEEK(137)*256	Beginning of program

Use these only when program running

PEEK(140) + PEEK(141)*256	End of program and beginning of dimensioned variables
PEEK(142) + PEEK(143)*256	End of dimensioned variables and beginning of stack
PEEK(144) + PEEK(145)*256	End of memory used by program

Look at Table 3. The third entry in the variable value table is the string ALPHA\$. Its current length is 5 + 0*256 or 5. These two bytes must be set to the correct length of the string. Type the command: PRINT PEEK(134) + PEEK(135)*256. Now you know where the variable value table is. If you have been writing the program in the listings, you should get the answer 2056. Assume the string is the first entry in the table. The locations of the length is

Table 3

The variable value table: Each entry is eight bytes.

Variable	Contents	Table Entry								Meaning
		1	2	3	4	5	6	7	8	
AB1	5	0/	0/64	5,0,	0,0,	0				First byte is 0: this is a number. Second byte is 0: this is the first entry. 64 is the exponent. 5 is the binary coded decimal value.
AR(3,4)	doesn't matter	64 +	1/1/0,	0/4,	0/5,0					64 makes this an array. +1 means that it has been dimensioned. 0 + 0*256 is the displacement into the array area. 4 + 0*256 is the size of the first dimension and 5 + 0*256 is the size of the second dimension.
CDOG(17)	doesn't matter	64 +	1/2/120,	0/18,	0/1, 0					This array is displaced 120 bytes into the array area, and it is dimensioned 18 + 0*256 by 1 + 0*256.
ALPHA\$(10)	"12345"	128 +	1/3/228,	0/5,	0/10, 0					128 makes this a string. +1 means that it has been dimensioned. It starts 228 + 0*256 bytes into the array area. The current length of the string is 5 + 0*256. The maximum size of the string is 10 + 0*256.
E	.05	0/	4/63	5,0,	0,0, 0					This is a number. The exponent is now 63 so the number is only 1/100 of its integer value, or .05.
FIG	-5	0/	5/64 +	128/5,	0,0, 0					This is a minus number (+128 on exponent)

Table 2

The variable name table: Entry lengths are different. Box symbolizes that 128 is added to ASCII value of last character to show the name's end.

Variable	Variable name	
AB1	AB 1	3 character number name
AR(3,4)	AR 	2 character array name
CDOG(17)	CDOG 	4 character array name
ALPHA\$(10)	ALPHA \$	6 character string name
E	E	1 character number name
FIG	FI G	3 character number name

Note: Variable names can be up to 120 characters long and are completely unique. Variable ABC is different from variable ABCD. Variable names DO NOT appear in the program in memory. Only a 1 byte pointer to the variable name in the variable name table appears.

2060 and 2061. Since the length of the string of data being saved in the example is 10, I set location 2060 to a 10 in line 60 of the program.

Try it out

The program is complete. Save it. Now Run it. You will probably get garbage in the print out. Put a 10 character string in the string variable. Now put numbers in various entries in the B array. Typing a 9 for the I subscript will end the program with a CSAVE. Do this CSAVE onto a new tape. Turn the computer off and on. Now load this new copy of the program and run it. Viola! The data is still there! Now load this new copy of the program and run it. Viola! The data is still there! Now just imagine that this was your budget information, address book or other files. You have a no-hassle one-tape system.

Conclusion

I have provided more information about this internals of the Atari than is really necessary to solve this problem. If you are interested in this kind of information, study it. If not, skip it. If you have any questions, I would be glad to answer them. One warning. Do not press break while the program is running and then type RUN. Always use the CONT

command after pressing BREAK. Otherwise the statements in lines 10-40 will destroy the program data. This can be prevented if you know what the correct value of A should be in line 10. Replace line 10 with 10A = n, where n is this number. Do this for your finished product.

```

10 A=PEEK(140)+PEEK(141)*256-82
20 POKE 141,INT(A/256):POKE 140,A-PEEK(141)*256
30 POKE 143,INT(A/256):POKE 142,A-PEEK(143)*256
40 POKE 145,INT(A/256):POKE 144,A-PEEK(145)*256
50 DIM A$(10),B(2,3)
70 ? A$
80 FOR I=0 TO 2
90 FOR J=0 TO 3
100 PRINT B(I,J),
110 NEXT J
120 PRINT
130 NEXT I
140 ? "STRING=";:INPUT A$
150 ? "I=";:INPUT I
160 IF I=9 THEN 200
170 ? "J=";:INPUT J:A=B(I,J)=A
190 GOTO 150
200 A=PEEK(140)+PEEK(141)*256
210 A=A+82
220 POKE 141,INT(A/256):POKE 140,A-PEEK(141)*256
230 CSAVE

```

The Atari Basic Symbol Table

Most Basic interpreters assign values to the symbol table as the program is run. Not true with the Atari. New variables are placed in the symbol table when the program line they are contained in is first typed.

If you later change variable names, the old variable names are not removed from the table. They stay forever! Even the CLR command does not remove them. They continue to take up room. How much room? 8 bytes plus the length of the name. Add another byte if the variable is an array.

Fortunately, it is possible to clean up the variable table. Write the program to cassette using the command LIST"C", type NEW, and then reload the program from tape with the command ENTER"C".

A program can often be made to run faster by placing selected variable at the beginning of the variable table. This decreases the time it takes to find variables which are used in time-critical routines.

To place these variables at the beginning of the variable table, write the program to cassette using the command LIST"C" and then type NEW. Now use those variables. For example, if the variable A must be the first variable in the table, type A = 0. If the string B\$ must be used, type DIM B\$(1). You are "ordering" the variable table. When you have finished placing as many variables in their correct order as you want, load the program you saved to tape with the command ENTER"C". This does not interfere with the contents of the variable table.

Changing Atari program to save the dimensioned variables.

- Get the program working.
- Place the string variables at the beginning of the variable table.
- Change the program so that it internally points the program-end address past the dimensioned variables and then saves itself to tape.
- Run the program, creating a copy on tape.
- Turn the computer off, on, and then reload the program.
- Add the statements to the beginning of the program to correct the program-end pointer, stack pointer, and end-of-memory pointer.
- Add the code to restore the actual string variable lengths to the variable value table.
- Save your finished program to tape.

Figure 1:
Basic Program Memory Layout

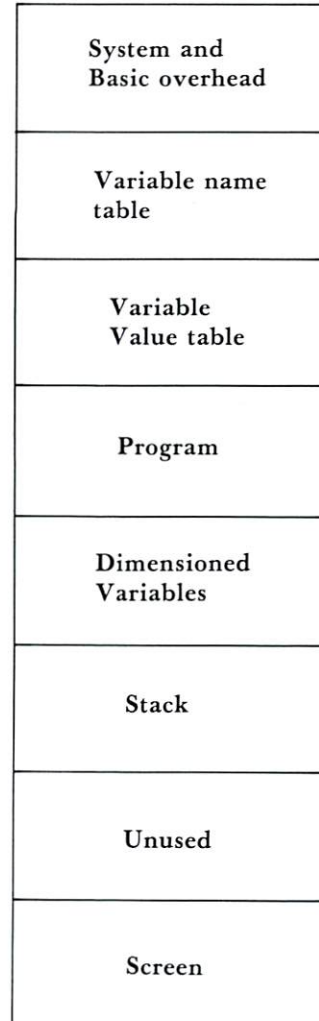

IRIDIS™

FOUR EXCELLENT PROGRAMS FOR YOUR ATARI™ 800

CLOCK

No—this isn't another digital clock! It's an old-fashioned wall clock, with chimes to charm you. And it keeps on ticking . . .

ZAP

Grab a joystick and try to zap the targets. Has an "attract" mode when you don't want to play. You'll also learn how to use the **ATARI** **START** button in your Basic programs.

LOGO

A flashy demo that shows off the **ATARI** color registers.

POLYGONS

Your **ATARI** constructs beautiful geometric patterns.

IRIDIS #1 is available now. You get a C-30 cassette or a high-quality diskette with four excellent programs for your **ATARI** 800. The programs are ready to "Load" and "Run". You also receive the 24 page **IRIDIS** GUIDE which provides clear instructions for the programs, as well as important information about how to get more out of your **ATARI**.

Our programs are written to be studied as well as used. The GUIDE will have complete source listings of selected **IRIDIS** programs. Not just listings, but an explanation of what's going on. If you are new to programming, **IRIDIS** is one of the easiest ways you can learn advanced techniques. If you're an old hand, you'll still find **IRIDIS** to be a rich source of ideas and **ATARI** techniques.

ATARI is a trademark of **ATARI, Inc.**

Please send me **IRIDIS** #1 for my **ATARI** 800 immediately.

- \$9.95 Cassette \$12.95 Disk

Name _____

Address _____

City _____

State/Zip _____

VISA Card Number _____

MasterCharge Expires _____

Signature _____

Published By:



Box 550
Goleta, CA 93017
805-967-0905
Dealer Inquiries Invited.

"ENTER" WITH ATARI

Len Lindsay

The power to insert or append program segments is built right into your ATARI computer, even though it is not mentioned in the ATARI documentation.

Here is an example of how this capability can be utilized. Let's say you just finished writing a program called FASTTRAP. You have it saved either on tape (CLOAD) or an disk (SAVE "D:FASTTRAP"). Now you are developing another program called NEWPROG. There are several routines in FASTTRAP that you would like to include in NEWPROG. The hard way to do this, of course, is to type them in again. The easy way is to enter them from FASTTRAP, and here is how to do it.

Any program sections that you wish to merge into another program should be recorded on tape or disk using the LIST command. The format for tape is:

```
LIST "C:",sssss,eeee
```

The format for disk is:

```
LIST "D:FILENAME",sssss,eeee
```

The sssss should be replaced by the starting line number of the section, and the eeeee should be replaced by the ending line number. If you wish all the lines recorded you may leave off the line numbers.

There are two routines in FASTTRAP that you would like to use in NEWPROG. Lines 2000 to 20099 are a routine that allows the ATARI to determine which plug your joystick is attached to. With the program FASTTRAP in memory save the routine to tape like this:

```
LIST "C:",20000,20099
```

or to disk like this:

```
LIST "D:IDENTIJST.SUB",20000,20099
```

The other routine in FASTTRAP you would like to reuse is one that allows the user to easily choose what color his piece will be. It is in lines 20300 to 20399. Save this routine to tape like this:

```
LIST "C:",20300,20399
```

or to disk like this:

```
LIST "D:COLORSET.SUB",20300,20399
```

You still have your program FASTTRAP saved on tape or disk. In addition you now have two other tapes or two other disk files, as created above. Now type NEW and enter your new program, NEWPROG, as usual. At any time during your programming you may append the routines previously recorded. Here is how you would insert the routine to set the piece color from tape:

```
ENTER "C:"
```

or from disk:

```
ENTER "D:COLORSET.SUB"
```

Now you might as well insert your other routine like this (from tape):

```
ENTER "C:"
```

or from disk:

```
ENTER "D:IDENTJST.SUB"
```

After you have inserted these, do a LIST and you will see that your program does indeed now include the two routines. Lines ENTERed in this manner will automatically be placed in the appropriate section of the program (by line number). If an identical line number is already used in your program, it will be replaced by the one you are ENTERing. You can insert or append program sections in any order you wish. If you accumulate a library of subroutines in this manner, writing new ATARI programs will be easier, since some of the program is all ready to go, ready to be ENTERed whenever you need it. ©

Atari Program Saving-Part II

Len Lindsay

Last issue I listed some methods of SAVING a program to tape. Here are the updates for disk.

To save a program to disk in the normal way (tokenized form) enter this:

```
SAVE "D:FILENAME.EXT" [RETURN]
```

If you have more than one disk, you can save to disk number two by using D2 in place of the D in all examples.

A program saved in this normal manner can be loaded back by this command:

```
LOAD "D:FILENAME.EXT" [RETURN]
```

You also can save your program onto disk in its untokenized form like this:

```
LIST "D:FILENAME.EXT" [RETURN]
```

It then can be read back using this command:

```
ENTER "D:FILENAME.EXT" [RETURN]
```

Using LIST, you can save the whole program (as above) or just a section of it. To save any section, simply specify the starting and ending line numbers of that section like this:

```
LIST "D:FILENAME.EXT",100-900 [RETURN]
```

This will save just lines 100 through 900. ©

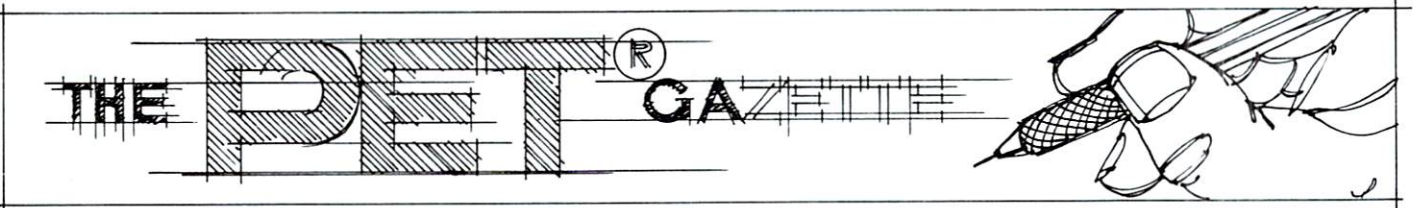

Tom Conrad
7167 Via Lomas
San Jose, Calif. 95136

Block Access Method Map for a Commodore 2040 Disk Drive

Detail Explanation

00 : 12 01 01 00

a	b	c	d
15	FF	FF	1F

- a - Total free sectors for track 1. In this case it is hex 15 or decimal 21. Since track 1 has a maximum of 21 sectors, track 1 is totally empty.
- b - The bit configurations for sectors 0 thru 7. Bit on means empty sector and bit off means allocated sector.

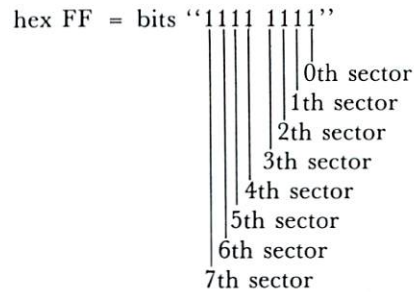

- Therefore all sectors are empty.
- c - bit configurations for sectors 8 thru 15

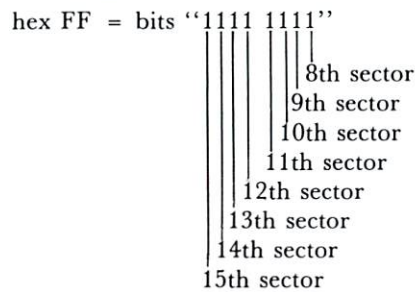

- d - bit configurations for sectors 16 thru 20.
- hex 1F = bits "0001 1111"

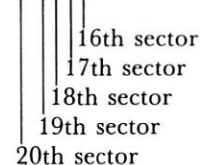

In any empty disk, the 'd' byte changes from 1F, 0F, 03, 01 to compensate for varying number of sectors per track.

- hex 1F is the pattern where there are 21 sectors as in tracks 1 thru 17.
- hex 0F is the pattern where there are 20 sectors as in tracks 18 thru 24.
- hex 1F is the pattern where there are 18 sectors as in tracks 25 thru 30.
- hex 1F is the pattern where there are 17 sectors as in tracks 31 thru 35.

OVERVIEW

The Block Access Method (BAM) map program will allow you to see where your files are allocated. You can save and delete files and observe the allocation technique.

DESCRIPTION

The purpose of the BAM is to protect allocated files so they are not written over and therefore destroyed. The BAM map resides on the directory track 18. The BAM is in the first half of sector 0. The layout looks like this:

BAM Dump

TRACK 18 SECTOR 0

a	b	Track NUMBER								
00 :	<table border="1" style="display: inline-table; vertical-align: middle;"><tr><td>12</td><td>01</td><td>01</td><td>00</td><td>15</td><td>FF</td><td>FF</td><td>1F</td></tr></table>	12	01	01	00	15	FF	FF	1F	1
12	01	01	00	15	FF	FF	1F			
08 :	15 FF FF 1F 15 FF FF 1F	2 3								
10 :	15 FF FF 1F 15 FF FF 1F	4 5								
18 :	15 FF FF 1F 15 FF FF 1F	6 7								
20 :	15 FF FF 1F 15 FF FF 1F	8 9								
28 :	15 FF FF 1F 15 FF FF 1F	10 11								
30 :	15 FF FF 1F 15 FF FF 1F	12 13								
38 :	15 FF FF 1F 15 FF FF 1F	14 15								
40 :	15 FF FF 1F 15 FF FF 1F	16 17								

48 :	12 FC FF 0F 14 FF FF 0F	18 19								
50 :	14 FF FF 0F 14 FF FF 0F	20 21								
58 :	14 FF FF 0F 14 FF FF 0F	22 23								
60 :	14 FF FF 0F -----	24								

	12 FF FF 03	25								
68 :	12 FF FF 03 12 FF FF 03	26 27								
70 :	12 FF FF 03 12 FF FF 03	28 29								
78 :	12 FF FF 03 -----	30								

	11 FF FF 01	31								
80 :	11 FF FF 01 11 FF FF 01	32 33								
82 :	11 FF FF 01 11 FF FF 01	34 35								

- a - Address of the next sector which is where the directory begins.
- b - The start of the BAM map for track 1.

OBSERVATIONS USING THE BAM MAP PROGRAM

The BAM turns off the bits when it allocates a sector. The BAM Map Program looks at these bits and if the bit is on (meaning it is free and has not been allocated) it will print either a "⦿" or a white square. By looking at the map you can determine how full or empty the disk is.

Varying numbers of sectors.

The reason for the varying number of sectors per track is to pack more data on the disk. Using the worse case which is 17 sectors per track and propagate throughout the disk would decrease the number of sectors per track by 95 sectors or 24k.

Sectors not contiguous

The sectors are in 255 byte blocks. A program file, which is stored in 255 bytes, is not written on the disk contiguously but written approximately one-half track apart. Using the BAM program, you can see when you save a program on a empty disk, that DOS will save the first 255 bytes on track 17 sector 0, the second 255 bytes on sector 10, the third 255 bytes on sector 3, and so on. The purpose of these gaps is to speed up the processing by not

waiting for a full rotation of the disk. If the program was written contiguously after each write, DOS would have to wait an entire rotation of the disk to write the next sequential sector. Thus, when one is looking at the BAM Map, one will see where alternating sectors are allocated.

Allocation of sectors

DOS allocates disk space very efficiently. Sectors are allocated around the directory (track 18). This reduces the read/write head movement because it reads the directory first, then reads the file. By having the file close to the directory, head movement is reduced.

Where sectors are allocated

When you delete the first program on a full disk, the BAM Map will show free sectors near the directory. When you save a new program, it will start by allocating those free sectors nearest the directory and will start filling in where you deleted the old file. If the new program is larger than the old program, it will try to allocate sectors further and further from the directory. By using this allocation technique, the need for a disk compress is eliminated.

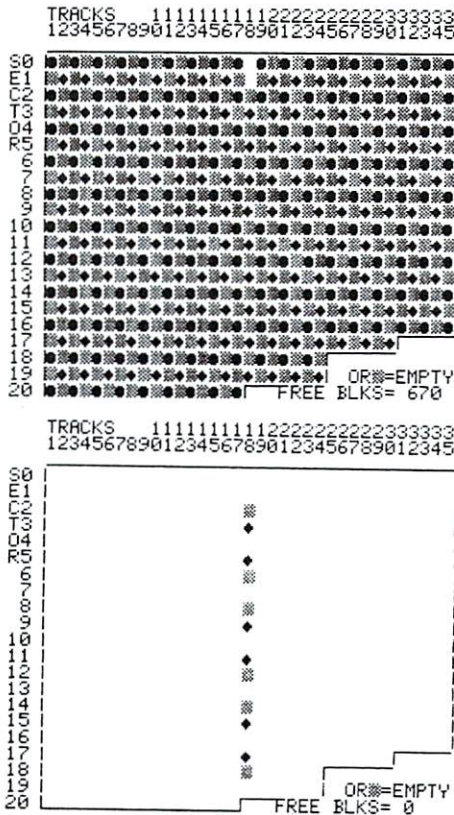

PROGRAM EXPLANATION

```

100-170 Initialization
180-190 Which drive?
200-430 Prints the BAM Map outline.
100 REM* BLOCK ACCESS METHOD DUMP      *
110 REM* WRITTEN BY TOM CONRAD        *
120 REM*
130 REM*
140 REM*      INITIALIZATION          *
150 DIM A(4)
160 NL$=CHR$(0)
170 T=0: REM TOTAL FREE BLOCKS
175 REM* WHICH DRIVE      *
180 PRINT"␣␣␣␣DRIVE?"
190 GET D$: IF D$="" GOTO 190
195 REM* PRINTS THE BAM MAP OUTLINE *
200 PRINT"␣  rTRACKS␣  111111111222222
    -22222333333"
210 PRINT"      123456789012345678901234567
    -89012345"
220 PRINT"$ $$$$$$$$$$$$$$$$$$$$$$$$$$$$$
    -$$$$$$$$"
230 PRINT"rSf0!"
240 PRINT"rEf1!"
250 PRINT"rCf2!"
260 PRINT"rTf3!"
270 PRINT"rOf4!"
280 PRINT"rRf5!"
290 PRINT" 6!"
300 PRINT" 7!"

```

References:

Parsons, James C., "Display Track and Sector", Commodore Newsletter Vol. 1 Number 8, January 1980.
 Commodore Business Machines, Commodore CBM Dual Floppy Disk Model 2040 User Manual, July 1979.

```

440-460 Sets up S$ with 25 cursor downs. Sets up T$ with 40
      cursor rights.
470   Initializes the requested drive & checks for a disk error.
480   Allocates buffer 0 to channel 2 for block commands that
      follow.
490   User command that does a block-read. It reads from the
      requested disk, track 18, sector 0 into the disk buffer
      and checks for a disk error.
500   Set the channel 2 pointer to the 5th byte in the buffer
      where the BAM Map starts.
510   Memory-Read Command sets up the byte pointed to by
      the address 1700.
530-690 Read the BAM and look for empty sectors.
550   The GET# will receive one byte from the buffer via
      channel 15
560   The byte is in character data and if it is null needs to be
      changed to CHR$(0) otherwise statement 570 will
      abend in the conversion to numeric
570   Conversion to numeric
580   This calculates the total free sectors available. A(1) is the
      total free sectors for that particular track. The total is
      calculated by summing all the A(1)'s except Track 18
      which is reserved only for the directory and can not be
      allocated for any files.
610   Prints in the upper left corner a alternating ☒ and
      white squares to show when the program is running.
620   If sector is full (all bits are off) go to next byte.
630-670 Decodes the decimal number into bit pattern and check
      if bit is on.
640   same as 610
650   If the number minus the powers of 2 is greater or
      equal to zero then the bit is on and go to 790 to
      print ☒ on the screen.
700   Program is finished running now clear the square in the
      upper left corner
710   Print the total free blocks
720   Keep map on screen until any key is typed.
730   Close the files
740   Start program again.
750-780 Subroutine to check for disk error
790-850 Prints ☒ or white square for the empty sector.
840   The first LEFT$ is calculating how many cursor down
      (sector no.) are needed and the second one is calculating
      how many cursor LEFT$(track no.) are needed.
310 PRINT " 8!"      ☒
      ☒
320 PRINT " 9!"      ☒
      ☒
330 PRINT "10!"     ☒
      ☒
340 PRINT "11!"     ☒
      ☒
350 PRINT "12!"     ☒
      ☒
360 PRINT "13!"     ☒
      ☒
370 PRINT "14!"     ☒
      ☒
380 PRINT "15!"     ☒
      ☒
390 PRINT "16!"     ☒
      ☒
400 PRINT "17!"     ☒
      ☒
410 PRINT "18!"     ☒
      ☒
420 PRINT "19!"     ☒
      ☒
430 PRINT "20!"     ☒
      ☒
440 S$="": T$=""

450 W$="↓": FOR I=1 TO 25: S$=S$+W$:NEXT
460 V$=">": FOR I=1 TO 40: T$=T$+V$:NEXT
465 REM* INIT DRIVE AND CK FOR ERROR *
470 OPEN 15,8,15,"I"+D$:GOSUB 760
475 REM* ALLOC BUFFER 0 TO CHANNEL 2 *
480 OPEN 2,8,2,"#"+"0": GOSUB 760
485 REM* BLOCK-READ INTO BUFFER *
490 PRINT#15,"U1:2,"D$,18,0: GOSUB 760
495 REM* SET BUFFER POINTER *
500 PRINT#15,"B-P:2,4"
505 REM* MEMORY READ *
510 PRINT#15,"M-R"CHR$(0)CHR$(17)
520 REM* SEARCH FOR EMPTY SECTORS *
530 FOR I=1 TO 35
540 :FOR L=1 TO 4
545 ::REM* GETS A BYTE FROM BUFFER *
550 ::GET#2,A$
560 ::IF A$="" THEN A$=NL$
565 ::REM*CONVERSION FROM CHAR TO ASCI
570 ::A(L)=ASC(A$)
580 ::IF L=1 AND I<>18 THEN T=T+A(1)
590 :NEXT L
600 :FOR J=2 TO 4
605 ::REM* PRINTS ALTERNATING SQUARES *
610 ::PRINT "h&":IF INT(J/2)=J/2 THEN ☒
      ☒
620 ::IF A(J)=ASC(CHR$(0)) THEN GOTO ☒
      ☒
630 ::FOR K=7 TO 0 STEP -1
635 ::REM* PRINTS ALTERNATING SQUARES ☒
      ☒
640 ::PRINT "h&":IF INT(K/2)=K/2 THEN ☒
      ☒
645 ::REM* DECODES DECIMAL TO BIT *
650 ::IF (A(J)-2^K)<0 GOTO 670
660 ::A(J)=A(J)-2^K:GOSUB 790
670 ::NEXT K
680 :NEXT J
690 NEXT I
700 PRINT"h":REM* CLEAR SQUARE *
705 REM* PRINTS TOTAL FREE BLOCKS *
710 PRINT LEFT$(S$,22)LEFT$(T$,23)"FREE ☒
      ☒
715 REM* MAP ON SCREEN UNTIL KEY IS HIT*
720 GET Z$:IF Z$="" GOTO 720
730 CLOSE 2:CLOSE 15
735 REM* START PROGRAM AGAIN *
740 GOTO 170
750 REM* CHECK FOR DISK ERROR *
760 INPUT#15,EN$,EM$,ET,ES: IF EN$="00" ☒
      ☒
770 PRINT "rDISK ERROR:␣ " EM$ " " EN$,
      ☒
780 END
790 REM* PRINT ALTERNATING PATTERN *
800 IF INT(I/2)= I/2 AND INT(K/2)= K/2 ☒
      ☒
810 IF INT(I/2)<>I/2 AND INT(K/2)= K/2 ☒
      ☒
820 IF INT(I/2)= I/2 AND INT(K/2)<>K/2 ☒
      ☒
830 IF INT(I/2)<>I/2 AND INT(K/2)<>K/2 ☒
      ☒
840 PRINT "h" LEFT$(S$,3+((J-2)*8)+K) ☒
      ☒
850 RETURN

```



Said the Toolkit to the Word Processor: "You're in My Space!" Said the Word Processor to the Toolkit: "Let's Share...here's

Socket 2 Me™!"

From the original producer of peripherals exclusively for PET lovers everywhere . . . the device that allows you to select between the BASIC Programmer's Toolkit and the Commodore Word Processor II while they occupy the same address space.

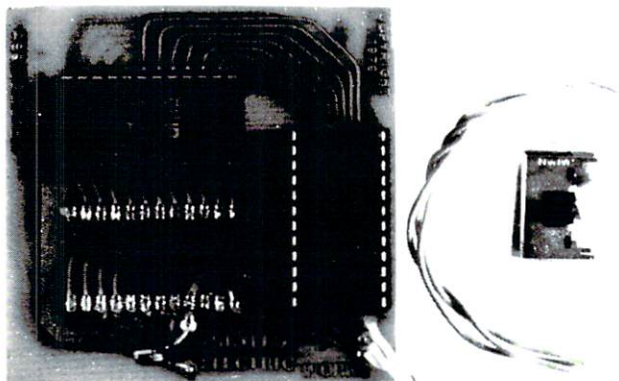

The **Socket 2 ME** . . . doubles your memory expansion in a single socket. It's a 2.5" x 2.75" board that fits neatly into the Toolkit/Word Processor socket on the main logic board of all *new* PETs. Then both the Word Processor and the Toolkit plug into the **Socket 2 ME**.

A miniature slide switch — part of the kit — mounts with double-stick tape (supplied) to the front part of the right side of the PET base, almost hidden by the overhang of the top of the PET cabinet. The slide switch is connected to the **Socket 2 ME** by a special cable (also supplied) . . . and you're up and running.

Up and running; installation took only a minute or so. Flip the switch from Toolkit to Word Processor. And back. No need to open the PET.

ORDER NOW — with Skyles' 10-day money-back guarantee:

Socket 2 ME: \$22.50*

Commodore Word Processor II: \$100.00*

Commodore Word Processor III: \$200.00*

BASIC Programmer's Toolkit

Model TK 80ED \$85.00*

Model TK 160ED \$95.00*†

*Add \$2.50 to each for shipping and handling.

†Note: If Computhink EPROM board is returned, after purchase of TK 160ED, Skyles will refund \$20.00.

"Socket 2 ME" is the trademark of Skyles Electric Works.

California residents: please add 6% or 6.5% sales tax as required

VISA, MASTERCARD ORDERS CALL (800) 538-3083 (except California residents)

CALIFORNIA ORDERS PLEASE CALL (408) 257-9140



Skyles Electric Works

231 E South Whisman Road
Mountain View, CA 94041
(415) 965-1735

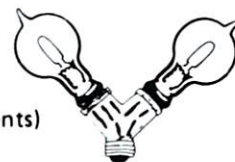

Complete with the first-rate installation and operating instructions you've come to expect from all Skyles documentation.

YOU HAVE AN ORIGINAL 2001-8 PET?

No problem. The **Socket 2 ME** interfaces with the BASIC Programmer's Toolkit model TK 160E or TK 160S connector board, the Word Processor II interfaces with the **Socket 2 ME**, the slide switch is placed on the PET base. Then, as long as the PET 2001-8 has at least 8K of memory expansion, the system is up and running.

YOU HAVE A COMPUTHINK DISK AND YOU WANT A BASIC PROGRAMMER'S TOOLKIT?

How would you like to switch between the Computhink and the Toolkit with a single SYS command?

Just add two small jumpers to the Computhink system and a short program to the DOS diskette. Plug in the BASIC Toolkit TK 80E, enter the **SYS** command and your system is up and running.

NO ROOM ON THE PET 2 COMPUTHINK DISK BOARD?

All your sockets are booked? Fret not; Skyles comes to the rescue. **Skyles Electric Works** now has a modified EPROM board available with sockets for the Toolkit and Computhink ROM chips. Plug in the ROMs, add a jumper (supplied) to the PET 2 Computhink disk board, plug the new EPROM board into the Computhink disk board. Power up and enter a short switching program into the DOS diskette. Switch between the Computhink disk and the Toolkit with a single **SYS** command.

PET SOFTWARE

LAS VEGAS CASINO SERIES:

These four programs were developed both as a tutorial for those planning to visit a Casino and wanting to learn to play correctly, and as a means for the serious gambler to develop and thoroughly test a gambling 'system' under actual Casino conditions. All betting odds and options available in the Casino of the MGM Grand Hotel in Las Vegas have been incorporated into these programs. Full screen graphics have been used to show the cards being dealt, the Roulette Wheel spinning, and the Dice being thrown in order to increase realism and heighten enjoyment.

1. CASINO BLACKJACK:

For 1 to 5 players plus the dealer. Keeps track of winnings or losses for each player plus number of hands won, lost, and tied and the number of times the dealer and each player has busted. Play with 1, 2, or 4 decks. Change decks or reshuffle at any time. Split pairs, Double Down, or place an Insurance bet. Full Casino rules and many other options \$ 7.95

2. CASINO ROULETTE:

Bet on one number, two numbers, odd, even, black, etc. Watch the numbers come up as the wheel spins. \$ 7.95

3. CASINO BACCARAT:

James Bond's favorite game. Two games in one. Casino style and Blackjack style. Includes special features to help in developing a winning 'system' \$ 7.95

4. CASINO CRAPS:

Bet the Dice to Pass or Fall Off. Bet the Hardway or Press with Double Odds. Ten ways to bet \$ 7.95

5. CASINO PACKAGE:

All four Casino Programs above \$24.95

STRATEGIC GAMES:

6. BACKGAMMON:

Play Backgammon against your PET. Excellent graphics and doubling option make for a fast and exciting game \$ 9.95

7. SPACE INVADERS: (with sound)

Written by COMMODORE-JAPAN. Performs exactly like the popular video arcade version being played all over the country. Machine language graphics and sound provide hours of entertainment \$ 9.95

8. CHECKERS:

Play against the PET. PET plays a good, fast game according to International Checker Rules. Excellent graphics show the board and all checkers. Watch your PET move his man around the board. Clock shows elapsed time for each move \$ 7.95

9. QUBIC-4:

This is three dimensional Tic-Tac-Toe played on four, 4 x 4 boards. PET plays a fast exciting game choosing one of three strategies for each game \$ 7.95

10. GO MOKU:

Ancient Chinese board game played on a 9 x 9 board. Get 5 men in a row before your PET. A different strategy for each game \$ 7.95

11. OTHELLO:

English game known as Reversi. Try to capture the PET's men before he captures yours. Play against the PET or against your friends. Fast and fun \$ 7.95

12. CRIBBAGE:

An Excellent version of this favorite card game. All cards are shown using PET's excellent graphics. The PET plays a cool logical game difficult to beat even for the best players \$ 7.95

13. GAME PACKAGE:

Any six of the above programs \$34.95

GUARANTEE: All programs are guaranteed to be free from errors and to load on any PET. Any defective tapes will be replaced free of charge.

Order From: **CMS SOFTWARE**, 5115 Menefee Drive, Dallas, TX 75277



☆ BUSINESS ☆ EXPERIMENTAL ☆ EDUCATIONAL
☆ TELECOMPUTING ☆ PERSONAL ☆ RENTALS

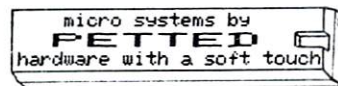

SPECIALIZING IN

Commodore Business Machines

PRODUCTS BY

CmC, NOVATION, TNW CORP., BIZCOMP, MICRO, CENTURY RESEARCH, TAB, POW'R PROTECTR, systems, BASE 2, OSBORN, Eaton, SOURCE, MACTRONICS, MicroNet, Skyles, KILOBAUD, Dr. DALEY'S, INSTANT SOFTWARE, ASCRO, MICRO SOFTWARE SYSTEMS, COMPUTER FORUM, COMPETITIVE SOFTWARE, HAYDEN, ATARI, NEECO, COMPUTE & COMPUTE II, DYSAN, CREATIVE COMPUTING, LIVERMORE RESEARCH, ROBOTICS AGE, SYBEX, KNIGHT ENTERPRISES.

Another Last Minute News Note: Commodore has announced that the three for two educational offer is on again.

Send For Our Free Catalog

Mail Orders To:

PETTED

P. O. BOX 21851
Milwaukee, Wisconsin 53221

PETTED micro systems

is located across from the SURFIN' TURF skate board park.
Highway I-894 & Hwy 36 4265 W. Loomis Rd.

Milwaukee, Wisconsin

VOICE (414) 282-4181 ☆ PBBS (414) 282-8118



TCB687

☆

10041,101



IN Michigan Dial PBBS#1 (313) 484-0732

☆ Vendors Display Your Products With Us. ☆

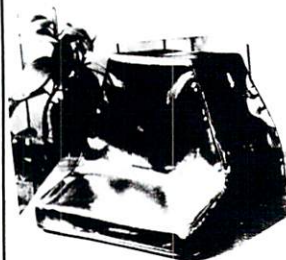

ITS COVERS . . .

**A BEAUTIFUL
COMPLEMENT
TO ANY DECOR!**

- Attractive, Durable, Leather-Grained Vinyl
- Double Stitching for Extra Strength
- Corded Seams Assure Perfect Fit
- Colors - Gold, Chestnut Brown, Olive Green or Black

PET/CBM - \$18.95

Apple II - \$12.95

Apple Disk - \$8.95

OTHER COMPUTER
COVERS AVAILABLE.
WRITE FOR DETAILS

NEW-CURSOR FOR PET 2001 OLD ROM

INSTANT PUSHBUTTON CURSOR RETRIEVAL

- Reviewed in Issue #1 of COMPUTE
- Restart without touching power
- Machine language programs in second cassette buffer not lost.
- Simple, illustrated instructions
- Installed in minutes - no soldering
- Improved mounting - no sticky tape

\$7.95

UNCRASHER for PET/CBM 2001 - New ROM - \$14.95

INTERNATIONAL TECHNICAL SYSTEMS, INC.

Box 264

Woodbridge, Virginia 22194



Phone Orders (804) 262-9709

SHIPPING AND HANDLING ADD \$1.00



RAMBLIN'

HARD COPY WITHOUT A PRINTER...

EVEN IF YOU'RE NOT A PHOTOGRAPHY BUFF, YOU CAN MAKE COPIES OF THE SCREEN CHEAPLY & EASILY WITH A CAMERA, AND IT'S NOT AS IMPRACTICAL AS IT SEEMS AT FIRST. IT COSTS ABOUT A BUCK TO GET A 24- OR 36-EXPOSURE ROLL OF NEGATIVES DEVELOPED, (LOOK FOR A PLACE WITH NEXT-DAY SERVICE), AND YOU CAN READ 'EM VIA A SLIDE PROJECTOR (IF YOU HAVE ONE), OR A HAND VIEWER (ANOTHER BUCK). IT'S CONVENIENT TO MOUNT THE NEGATIVES IN 2x2 SLIDE MOUNTS (AVAILABLE AT ANY PHOTO STORE). WHAT YOU SEE IS WHAT YOU GETS; A GREAT ADVANTAGE OVER MOST PRINTERS, WHICH DON'T HANDLE THE GRAPHICS & CURSOR CONTROLS WELL. (IF AT ALL!).

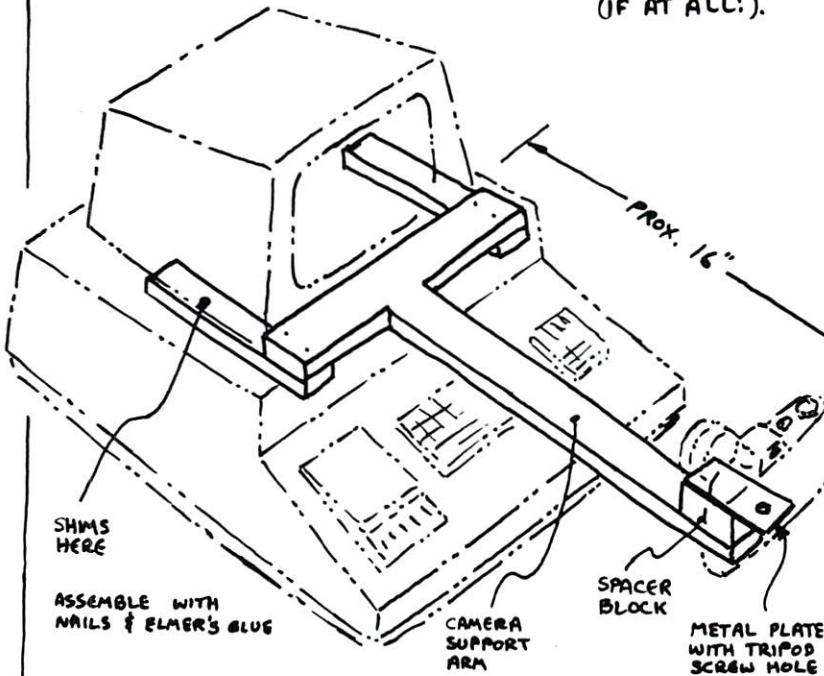

SHIMS
HERE

ASSEMBLE WITH
NAILS & ELMER'S GLUE

CAMERA
SUPPORT
ARM

SPACER
BLOCK

METAL PLATE
WITH TRIPOD
SCREW HOLE

EXPOSURE ~ SET THE SCREEN BRIGHTNESS CONTROL AS DIM AS POSSIBLE (FOR MAXIMUM SHARPNESS), AND USE A SLOW SHUTTER SPEED TO AVOID RASTER SYNCH PROBLEMS. IF YOUR CAMERA HAS AN INTERNAL LIGHT METER, IT WILL OVEREXPOSE, SINCE THE METER TRIES FOR AN AVERAGE DENSITY, OR 50%, AND MOST SCREEN IMAGES ARE 95+% BLACK. USING PLUS-X FILM (A.S.A. 125), TRY ONE SECOND AT f/11; USE A CABLE RELEASE. IF THE CHARACTERS TURN OUT DENSE & FUZZY, THEY'RE OVEREXPOSED; ADJUST ACCORDINGLY. TO USE AN INTERNAL METER, RUN THIS PROGRAM (MY FAVORITE ONE-LINER):

```
1 POKE 32768+1000*RND(1), 256*RND(1): GO TO 1
THE SCREEN WILL FILL TO 50% BRIGHTNESS; TAKE YOUR READING,
AND USE THIS EXPOSURE FOR ALL FUTURE SHOTS.
```

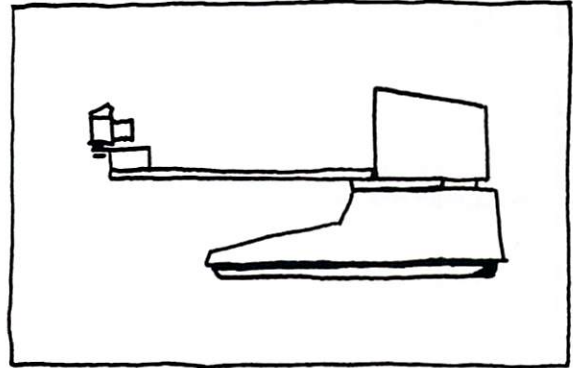

ALMOST ANY CAMERA CAN BE MADE TO WORK, BUT A 35mm SINGLE-LENS-REFLEX (SLR) MAKES THINGS VASTLY EASIER. A NO. 2 CLOSEUP LENS WILL GET YOU CLOSE ENOUGH TO FILL THE FILM AREA WITH THE SCREEN IMAGE. FOR SIMPLE CAMERAS & POLAROID, EXPERIMENT WITH A PIECE OF TRACING PAPER TAPED TO THE OPEN CAMERA BACK TO GET THE RIGHT DISTANCE & FOCUS.

ONCE YOU'VE GOT YOUR DIMENSIONS WORKED OUT, MAKE A FRAME (5/8" PLYWOOD IS FINE), WHICH SLIPS ON & OFF EASILY. IF 5/8" IS TOO SLOPPY, GLUE CARDBOARD &/OR FELT SHIMS TO THE ARMS WHICH GO BETWEEN THE TV & COMPUTER CABINETS. THE SPACER BLOCK HEIGHT WILL DEPEND ON YOUR CAMERA, BUT SHOULD PUT THE LENS ABOUT 3 1/2" ABOVE THE CAMERA SUPPORT ARM.

AN EARLIER COLUMN ABOUT THE CB2 LINE GENERATED SOME MAIL ABOUT MAKING MUSIC ON THE PET. SEND A SASE TO THE ADDRESS BELOW FOR A LISTING OF THE NEIL HARRIS - JIM BUTTERFIELD PROGRAM AND KEYBOARD OVERLAY WHICH WILL TURN PET INTO AN ELECTRONIC ORGAN WITH RECORD/PLAYBACK CAPABILITY.

ROY O'BRIEN, BOX 426, BEAUMONT, CA 92223

FLOPPY DISK FOR PET, KIM, SYM, AIM - S100 EXPANSION

ALL IN ONE

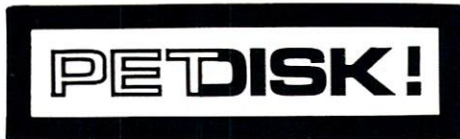

- ADD I/O, VOICE, MEMORY
- LOAD, SAVE INSTANTLY
- PLUG-IN HOOK UP
- UP TO FOUR DISK DRIVES

The **PEDISK SYSTEM** from CGRS Microtech provides both a high speed FLOPPY DISK and an S100 EXPANSION chassis all in one! The FLOPPY DISK provides the PET computer with means to instantly load and save programs and information. Tired of waiting for your cassette? The optional S100 EXPANSION chassis gives the power and versatility of the S100 bus to the PET. The extensive and diverse product offerings on the S100 bus include Memory, I/O, Telephone Interface Cards, IBM Selectric Interface, Analog I/O, Voice Generators and even Voice Input Cards.

The **PEDISK SYSTEM** offers an economical solution to the problem of expanding the PET. It offers complete expansion capability in a single package. The FLOPPY DISK uses the IBM 3740 format to promote compatibility with other systems (Radio Shack). The S100 EXPANSION uses the most widely supported microcomputer bus in the industry. Standard, Economical Expansion - The **PEDISK SYSTEM**

The KM³ Software is furnished with each package and is available with the EXS100 Board. This software allows the user to LOAD, SAVE, RUN, and UPDATE files on the disk. In addition, Rev. 2 software will allow the user to OPEN, CLOSE, INPUT, and PRINT a disk file. The commands will execute directly or from a program.



*PET is a trademark of Commodore.

COMPLETE SYSTEMS.....

PACKAGE 1	EXS100 DISK CONTROLLER MINIFLOPPY DISK DRIVE CABINET & DISK POWER SUPPLY	\$799.95
PACKAGE 2	EXS100 COMBINATION DISK/S100 BOARD MINIFLOPPY DISK DRIVE CABINET & S100/DISK POWER SUPPLY 3 SLOT S100 CHASSIS	\$895.00

PARTS.....

EXS100 BOARD		
	Assembled as an S100 Adaptor only	\$199.95
	Assembled as an Disk Controller only	\$299.95
	Combination Disk/S100 Board	\$349.95

MICROTECH
P.O. Box 368
SOUTHAMPTON, PA. 18966
(215) 757-0284

PET RABBIT



Load, Save, Verify, Execute
8 K in 38 seconds versus
PETs 2 Minute 45 seconds,
plus more!

High-speed Cassette Routines work with 8K, 16K, or 32K new ROM PETs which have the new Commodore cassette deck (like the external version which sells for \$95.00). Note: If you have a new ROM PET with the old style lift-top deck, everything but the high-speed cassette routines will work.

- Auto repeat of any key held down, toggle character set.
- RAM Memory Test, convert #'s to hex and decimal.

12 Rabbit Commands

Note: Rabbit is 2K of machine code at \$1800 for 8K PETS, \$3000 or \$3800 for 16K PETS, or \$7000 or \$7800 for 32K PETS. (Specify one of the 5 versions.)

Cassette and Manual - \$29.95 (Add \$5.00 for foreign)

Eastern House Software

3239 Linda Dr. Winston-Salem, N. C. 27106

Q D S

QUICK & DIRTY MACHINE LANGUAGE SORT FOR PET™ BASIC PROGRAMS

Given one or more arrays A\$(I), B\$(I), C(I), etc., QDS extracts keys of specified length, sorts at machine language speed (30 times BASIC) and generates an array of the indices of the chosen array in order. For example, given the arrays:

A\$(0) = "B"	B(0) = 12
A\$(1) = "C"	B(1) = 10
A\$(2) = "A"	B(2) = 15

Sort on A\$ generates	Sort on B generates
J(1) = 2	J(1) = 1
J(2) = 0	J(2) = 0
J(3) = 1	J(3) = 2

Not elegant Just - FAST - AVAILABLE - USEABLE

Locates in upper memory below DOS 4.0. With Demo and instructions: For new ROMs only.

32K PETs	QDS7C00	\$6.95
8K	QDS1C00	\$7.95
16K	QDS3C00	\$8.95

On disc for 2040 - add \$3.00 CA orders - add 6%

G E Enterprises
1417 11th St. Manhattan Beach, CA 90266

CHEEP PRINT Hard Copy For Soft Cost

C. A. McCarthy
1359 W. Idaho Ave.
St. Paul, MN 55108

CHEEP PRINT SOFTWARE

Cheep Print for PET is written mostly in BASIC; a little bit of machine code is used to insure accuracy in timing the output signals. I have chosen to put the machine code in the second cassette buffer, but the code is completely relocatable and may, for instance, be placed in high memory if you change the top-of-memory pointer and command CLR before trying to run the program (neglecting CLR causes strings to overwrite the machine code; you can guess how I found this out.)

The BASIC part of Cheep Print is designed to live at the beginning of some other program, which I will refer to as the host program, and serves both to list the host program while it is under development and as data output software after the program has been completed. The host program is assumed to have line numbers of 100 and up. I have tried to structure Cheep Print so that it contains subroutines that can be called by the host program. If you look over the listing of Cheep Print, which was produced by Cheep Print itself -- the comments were added afterwards for documentation -- you will see that most of the program is taken up with formatting the output for the printer, and with the details of listing a program.

To use Cheep Print, start by making a master copy of the program that contains all the options that you might ever need; this copy should be saved for future use. Then make a sub-master that has the various parameters and options for the printer that you will be using most. You can simply load the master and delete those options that aren't needed, incidentally gaining more space for the host program. You will probably want to use Cheep Print to list itself a few times, just to make sure that the formatting is satisfactory, and to gain familiarity with the sequence of operations required. When you are about to start developing a new program, enter the sub-master copy of Cheep Print and then key in the host program. As you save your host program, Cheep Print will come along with it. Line 1 of Cheep print is a GOTO to the entry point of your host program, so that a simple RUN command will execute the host program. If you want a listing of any part of the program, simply command RUN 10; you will be prompted to check that your cassette recorder is properly set up -- cables connected and running in record mode -- and then you will be asked which lines you want listed. The options are the same as for the screen listing on PET: hit RETURN only, and get everything; enter A-B (a hyphen must be used as a separator here) and you get lines A through B inclusive; A- gives everything from

A onwards, B- gives everything up through B; and A alone, with no hyphen, lists the single line A. As the program listing proceeds, the line that is currently being processed for the Cheep Print output is listed at the top of the screen. When the message "BREAK IN 80" appears, the listing is done and you can turn off the recorder.

One of the Cheep Print listing options is to put each statement on its own private print line, thus leaving much welcome space for comments. I have used this style for the listing of Cheep Print; I hope that the comments on this listing suffice to explain what is going on, and how to structure the various options for your specific needs. There is, however, one point that must be emphasized. The LIST instruction of line 2 needs to have precisely five characters as argument. The first time that you enter Cheep Print from the keyboard, key in something like 2 LIST-LINES or 2 LIST12345. This is important because eventually line numbers are going to be POKED here by the commands of line 19; we need to leave enough room for the longest possible line numbers of five digits.

The other principal subroutines of Cheep Print, which the host program may find useful, are:

3-4 contains identification information such as the name of the program, date, revision, etc.; I have found this useful also when SAVEing or VERIFYing a program with PET's internal cassette recorder. The command LIST 3 puts this data on the screen, then I type the word "SAVE" and two spaces over the line number and S\$; hit RETURN, and the program gets saved with a title, without the fuss of entering the title by hand.

7 outputs the string P\$, and 8 outputs the single character which has ASCII code P.

39 effects a carriage return and linefeed, and updates the variables PX and PY which give the current print position at the printer.

40-41 checks whether it's time for the printer to go to the next page, and if so, it executes 42-44.

42 linefeeds to the end of the current page,

43 is an option, useful for continuous roll paper; if the initial "RETURN" is deleted, a line of hyphens is printed at regular intervals, so your paper can be cut neatly into single sheets of uniform size. With fan-fold paper, line 43 may be ignored.

44 linefeeds to the top margin of where you want to start printing on the paper.

45-49 format the string S\$ for output: space from the left edge of the paper to the left margin, print S\$ if it fits on the current line; if it doesn't fit, output as much as does fit, and then repeat the process with the portion of S\$ that's left over.

70 is a general purpose start-up routine. It calls

50 to start outputting MARKS, pokes the lower case mode for PET screen output, and then calls 52 for the prompt to check that your cassette is running and 54 to initialize variables and the details of paper size and format that you wish to use.

71 simply outputs the current S\$, then carriage returns and, if required, linefeeds to the next page.

80 cleans up: linefeed to a blank page so that garbage created by turning off the audio doesn't spoil the beautiful page that Cheep Print has just produced, then ding the bell on the printer to announce that it's done, followed by a wait loop for a little trailer on the tape. Then the shift register at 59467 is reset so that the PET tape read and write will operate properly and the graphics mode for screen output is restored.

98 converts the hex string Q(uey)\$ into the equivalent number A(nswer).

99 loads (hex machine) C(ode)\$ into memory locations beginning at MA.

Lines 5 and 6 serve only as an index to the program lines that structure Cheep Print for the printer you use. I have included the most common options in the listing.

Line 23: with the REM, we list the program with extra space for comments. Delete the REM, and the program is listed single spaced, with the print output strung across the whole page. This is useful during development; not only does it execute more quickly, but it is an advantage to have as much as possible of the program in view at once, provided that the details of what is supposed to happen are fresh in your mind.

Lines 50 and 63-66 are involved in setting the baud rate and whether originate or answer mode. In line 50, only the mode needs to be determined, and the two possible choices are snuck in following the REM. Lines 63-66 contain that portion of the machine code which depends upon the baud rate and the mode. The four options given are receive and originate mode at 110 and 300 baud (10 and 30 characters per second), and which one you use is determined by which of the initial REM's isn't there. Table 2 gives the details of getting output at different frequencies and baud rates. The timing parameters MF and SF determine the mark frequency and the space frequency appropriately for you to be in originate or answer mode; the decimal equivalent of MF also needs to be reflected in the initialization at line 50. Usually you will want to be in answer mode when talking to a terminal and in originate mode when talking to a mainframe. The baud rate is determined by the timing loop parameters XR and YR, and the duration of the stop bits by SB. I did some experimenting with these parameters and found that the baud rate could be off by 7 or 8 percent and the mark and space frequencies off by 4 percent and still get solid copy; SB only needs to be sufficiently long. The output can be structured in

any way you wish, of course; for instance, you could generate tapes to Kansas City standards if you wish. The most important thing is that your cassette recorder should run at the same speed at home as it does at your printer, but it doesn't matter what the speed is. If you are forced to use battery operation at your printer, then you should use battery operation at home or else experiment with the timing parameters to compensate for the speed difference that many recorders exhibit between battery and AC line operation.

Lines 85-86 contain the formatting data for the two styles of listing, and lines 87-88 contain two types of carriage return- line feed sequences. These are implemented by LISTing 85-88 on the screen, deleting the line number and REM from the data you wish to use, and then hitting RETURN; the PET screen editor picks up the line number 55 or 56 that remains and inserts these statements into the program. Lines 85-88 remain unchanged for future use. The carriage return-line feed sequence that you need will depend on the printer you use. I've used a DECwriter and a thermal printer in which carriage return (Control-M) does not also give a line feed (Control-J), and a Selectric which includes the line feed with the carriage return whether you like it or not. Further, the DECwriter requires no nulls to waste time while the print head returns to the left side of the paper, the thermal printer sometimes requires as many as four nulls, and the Selectric wants a goodly number of nulls. The Anderson-Jackson Selectric has an 800 character buffer to deal with transmission faster than the print mechanism can keep up with, and the nulls plus the program execution time seem to be enough to keep the buffer from overflowing. If you have a Selectric, one solution is to make every other character a null, which is included in the REM of line 8; if you use these nulls, declarations of P will have to go inside the FOR-NEXT loops of lines 44, 47, 53, 22, and 17. I doubt that the line 8 nulls are a good solution for a Selectric, because there is a mechanical clutch that continually engages and disengages, and probably wears more than it needs to. This clutch is also the reason that the listing output is generated line by line, rather than simply printing individual characters when ready;

As an example of using Cheep Print to serve a host program, I wrote a quick 6502 disassembler in Basic so that Cheep Print could list its own machine code for commenting. The disassembler isn't included here because there's nothing particularly exciting or instructive about it. The disassembly shows that the machine code is only a simple software timing loop, performed with interrupts inhibited (this is important!) so that the timing doesn't get messed up. The machine code outputs the start bit, and then the contents of memory location 1023/03FF low order bit first. All the printers I know ignore the highest

order data bit, so I let programming convenience override generality, and output the highest order bit always as a mark, followed by sufficient marks to act as stop bits and marks until the next data come along.

Table 2 Output parameters

A. The frequency output by the 6522 shift register is given by the formula

$$\text{Frequency} = \frac{\text{System clock frequency}}{4 * (\text{contents of T2 low} + 2)}$$

assuming that the shift register contains 01010101 or 10101010.

The PET system clock appears to be spot on 1 MHz, and we calculate

For frequency	use T2 low
2225 Hz	6E hex = 110 decimal answer mark
2025 Hz	79 hex = 121 decimal answer space
1270 Hz	C3 hex = 195 decimal originate mark
1070 Hz	E8 hex = 232 decimal originate space

If desired, frequencies may be halved by using 00110011 in the shift register, and divided by four by using 00001111.

Depending on the equipment used, a certain amount of inaccuracy can be tolerated. I found no equipment that would give errors in the following ranges:

69 to 71 instead of 6E	B5 to D3 instead of C3
76 to 80 instead of 79	DA to F8 instead of E8

B. The timing loop as given by the present machine code yields

$$\text{Bit time} = 1284 \text{ XR} + \text{YR} - 1257$$

clock cycles between successive loads of 6522 T2 low, give or take one cycle due to the difference in execution times between mark and space caused by the branch at 0347.

With the PET's one microsecond clock period, we have

$$\text{XR} = \frac{\text{INT}(\text{Bit time} + 1257)}{1284}$$

$$\text{YR} = \text{Bit time} + 1257 - 1284 \text{ XR}$$

For baud rate	one data bit time	XR	YR	SB
110	9091 us.	08	OF (= 15)	16 (= 22)
300	3333 us.	03	93 (= 147)	07

4% error seems to be tolerable. For 110 baud, we can range from XR, YR = 07, C0 to 08, 60; for 300 baud we can range from 03, 70 to 03, B8.

```

1 GOTO 1000
2 LIST 99
3 S$="0.03 #14: CHEEP PRINT MASTER WITH -
  -DISASSEMBLER"
4 RETURN
5 LINE FUNCTION: 23 LIST STYLE: 43 ROLL -
  -PAPER:50,63-66 BAUD RATE
6 LINE FUNCTION: 55 PAGE FORMAT FROM -
  -85-86: 56 CRLF FROM 87-88
7 P=LEN(P$):IF P THEN FOR P0=1 TO P:
  -P=ASC(MID$(P$,P0,1)):GOSUB8:
  -NEXT P0:RETURN
8 POKE 1023,P:SYS(M0):RETURN:REM POKE -
  -1023,0:SYS(M0):RETURN:REM FILL -
  -NULLS
10 GOSUB 70:GOSUB 3:PRINT S$:INPUT -
  -"LIST <<<<";A$:GOSUB 58:GOSUB 60:
  -GOSUB 68
11 PY=PV-5:GOSUB41:GOSUB3:GOSUB71:
  -GOSUB39:S$="LIST "+A$:GOSUB71:
  -GOSUB39
12 A$=" "+A$+" ":A=0:B=0:F=1:FOR J=2 TO -
  -LEN(A$)
13 IF ASC(MID$(A$,J))=45 THEN A=VAL(LEFT
  -$(A$,J-1)):B=VAL(MID$(A$,J+1)):F=0
14 NEXT:IF F THEN A=VAL(A$):B=A
15 B=B-63999*(B=0):K=1025:K$="GOTO21"+CH
  -R$(13)
16 N=FNK(K+2):K=FNK(K):IF (K=0)OR(N>B) -
  -GOTO 80
17 IF N<A GOTO 16

```

TRAP 65

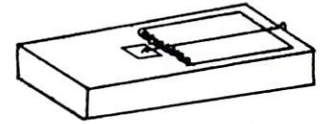

For PET, APPLE, SYM, OSI, etc.
Any 1 mhz 6502!

- Prevents from "hanging up" via execution of **unimplemented opcodes!** Causes your monitor to **display location** of bad op code!
- Our computers have stopped crashing!
- **Debugging easier!**
- **Easy to install** — plugs into 6502's socket.

TRAP 65 is currently being used to insure that there are no bad opcodes in programs before submittal for ROM masks!

We are using TRAP 65 in experiments on extending the 6502's instruction set — PHX, PHY, INCD.

~~\$148.95~~ (Add \$4.00 postage, \$10.00 foreign)
\$112.50 until June 15

Eastern House Software

3239 Linda Dr.

Winston-Salem, N. C. 27106

```

18 GOSUB 40:S$=RIGHT$( " "+STR$(N),5) :
  -FOR J=1 TO 5
19 POKE FNK(1025)+4+J,ASC(MID$(S$,J)):
  -NEXT:PRINT"n"
20 FOR J=1 TO LEN(K$):POKE 526+J,
  -ASC(MID$(K$,J)):NEXT:POKE 525,
  -LEN(K$):GOTO 2
21 Y=32848+LEN(STR$(N)):Z=32647+40*(PEEK
  -(245)-(FNK(K)=0))
22 IF PEEK(Z)=32 THEN Z=Z-1:GOTO 22
23 REM FOR J=Y TO Z:Q=PEEK(J):GOSUB 32:
  -S$=S$+A$:NEXT:GOSUB 71:GOTO 16
24 F=1:C=0:FOR J=Y TO Z:Q=PEEK(J):
  -F=(F+(Q=34))AND1:C=C-(F*Q=58):NEXT
25 IF PY<C>PV-PB THEN GOSUB 41
26 F=1:FOR J=Y TO Z:Q=PEEK(J):F=(F+(Q=34
  -))AND1
27 IF Q*F=58 THEN GOSUB 45:GOSUB 46:
  -GOSUB 39:S$=" ":GOTO 30
28 GOSUB 32:IF PL+LEN(S$)+LEN(A$) >= -
  -PH-PR THEN GOSUB 45:GOSUB 46:
  -GOSUB 39:S$=" "
29 S$=S$+A$
30 NEXT J:GOSUB 45:GOSUB 46:GOSUB 39:
  -GOSUB 39:GOSUB 40:GOTO 16
32 A$="":IF Q>127 THEN A$=CHR$(114):
  -Q=Q-128
33 IF Q>63 THEN A$=A$+CHR$(115):Q=Q-64
34 A$=A$+CHR$(Q-64*(Q<32)):RETURN
39 P$=R$:GOSUB 7:PX=1:PY=PY+1:RETURN
40 IF PY<PV-PB THEN RETURN
41 GOSUB 42:GOSUB 43:GOTO 44
42 FOR PY=PY-PV TO 1:P$=R$:GOSUB 7:NEXT:
  -PX=1:RETURN
43 RETURN:P=45:FOR PX=PX TO PH:GOSUB 8:
  -NEXT:RETURN:REM PAGE SEPARATOR
44 FOR PY=PY TO PT:P$=R$:GOSUB 7:NEXT:
  -PX=1:RETURN
45 IF PX<PL THEN FOR PX=PX TO PL:P=32:
  -GOSUB 8:NEXT:RETURN
46 PQ=PH-PR-PX:IF LEN(S$) <= PQ THEN -
  -PX=PX+LEN(S$):P$=S$:GOTO 7
47 IF PQ=0 THEN GOSUB 39:GOSUB 45:
  -GOTO 46
48 F=PQ:FOR J1=1 TO PQ:IF 32=ASC(MID$(S$
  -,J1)) THEN F=J1
49 S1$=MID$(S$,F+1):S$=LEFT$(S$,F):
  -GOSUB 46:GOSUB 39:S$=S1$:GOSUB 45:
  -GOTO 46

```

```

50 POKE59467,16:POKE59464,110:POKE59466,
  -85:RETURN:REM 59464~195=ORG;
  -110=ANS
52 PRINT "↑↑↑WHEN READY, HIT THE RETURN ↵
  -KEY"
53 INPUT "↑↑↑CHECK! DEVICE READY <<<<"
  -;A$:PRINT "↑↑OK":RETURN
54 S$="":J=0:P=0:PS="":Q=0:QS="":A=0
55 PX=0:PY=1:PH=79:PV=66:PL=12:PR= 3:
  -PT=6:PB=6:REM FOR COMPACT LIST
56 R$=CHR$(0):FOR J=1 TO 4:R$=R$+R$:
  -NEXT:R$=CHR$(13)+R$:RETURN:REM IBM
58 IF ASC(A$)=160 THEN A$=MID$(A$+" ",
  -2):GOTO 58
59 RETURN
60 DEFND(X)=X-40+7*(X>64)
61 DEFNK(X)=256*PEEK(X+1)+PEEK(X)
62 MA=826:M0=MA:C$="780EFF0338B014A2":
  -GOSUB99
63 REM:C$="08A00FA9E89002A9C38D48E888D0F
  -DCAD0FA186EFF03D0E79004A216":
  -REM OR110
64 REM:C$="08A00FA9799002A96E8D48E888D0F
  -DCAD0FA186EFF03D0E79004A216":
  -REM AN110
65 REM:C$="03A093A9E89002A9C38D48E888D0F
  -DCAD0FA186EFF03D0E79004A207":
  -REM OR300
66 C$="03A093A9799002A96E8D48E888D0FDCAD
  -0FA186EFF03D0E79004A207":REM AN300
67 GOSUB99:C$="D0E95860":GOSUB99:RETURN
68 FOR J=1 TO 8000:NEXT J:RETURN
70 GOSUB 50:POKE 59468,14:GOSUB 52:
  -GOTO 54
71 GOSUB 45:GOSUB 46:GOSUB 39:GOTO 40
80 GOSUB 41:P=7:GOSUB 8:GOSUB 68:
  -POKE 59467,0:POKE 59468,12:STOP
85 REM 55 PX=0:PY=1:PH=79:PV=66:PL=12:
  -PR=41:PT=8:PB=8:REM FOR COMMENTED ↵
  -LIST
86 REM 55 PX=0:PY=1:PH=79:PV=66:PL=12:
  -PR= 3:PT=6:PB=6:REM FOR COMPACT ↵
  -LIST
87 REM 56 R$=CHR$(0):R$=CHR$(13)+CHR$(10
  -)+R$+R$+R$+R$:RETURN:REM DEC CRLF
88 REM 56 R$=CHR$(0):FOR J=1 TO 4:
  -R$=R$+R$:NEXT:R$=CHR$(13)+R$:
  -RETURN:REM IBM
98 A=0:FOR J=1 TO LEN(QS):A=16*A+FND(ASC
  -(MID$(QS,J))) :NEXT:RETURN
99 FOR I=1 TO LEN(C$) STEP 2:QS=MID$(C$,
  -I,2):GOSUB 98:POKE MA,A:MA=MA+1:
  -NEXT I:RETURN
  
```

©

WHAT DO THEY SAY?

What do the reviewers say about SWORDQUEST and DEATH PLANET?

SWORDQUEST for the PET

"For those who want the very best."

- Recreational Computing

"The only fantasy simulation I have seen with graphics and animation."

- Pet Gazette

"Challenging and Exciting"

- Kilobaud Microcomputing

"The SWORDQUEST fever is once again at its peak."

- R. Zamora, Editor, Recreational Computing

You seek the jewels and holy sword in the tomb of a long-dead wizard. SWORDQUEST cassette and instruction booklet \$12.95

ESCAPE from the DEATH PLANET (with SOUND) for the PET

"Exciting Game"

- Popular Mechanics

"Fantasy Games Software has done it again... an exciting action game with good graphics, sound effects and real time programming. Graphics include animated laser fire and explosions."

- Kilobaud Microcomputing

Killer Robots and Imperial Stormtroopers search for you. Laser pistol combat inside a giant space station. DEATH PLANET cassette and instruction booklet \$12.95

Programs will run on any 8K or larger PET. Each cassette has both OLD ROM and NEW ROM versions.



Fantasy Games Software
P.O. Box 1683
Madison, Wisconsin 53701



Computer House Div.

Announces

Programing Tools For the Commodore/Disk

"SOF-BKUP" — \$40.00

Faster & Error Free Disk Copy

"FET/RECOVER" — \$65.00

File Editing Tool; Examine Data Files, Fix Destroyed Pointers, Sectors may be Read, Modified, Displayed or Written — Also Files may be Re-chained

"SUPER RAM" — \$20.00

Diagnostic Routine Checks Every Possible RAM Address on 8K, 16K & 32K Commodore Computers

Available on Diskette right now.....

All 3 above only \$105.00 retail

ENGINEERING & MACHINE SHOP Programs for Commodore System

"Machine Part Quoting".....	\$280.00
"Trig & Circle Tangent".....	70.00
"Bolt Circle".....	25.00
"Spur Gears".....	35.00
"Beams; Stress & Deflection".....	145.00
"Tank Thickness".....	
For Filament Winding.....	85.00

All 6 for only \$495.00

Programs for Apple

"Legal Accounting".....	\$1200.00
"Retail Accounts Receivable".....	400.00
"Political Party Mailing List".....	150.00

And many others coming soon — including RPG for Commodore — Ask for Catalog #80-C2.

COMPUTER HOUSE DIV.

1407 Clinton Road
Jackson, Michigan 49202
Phone: (517) 782-2132

Relocate PET Monitor Almost Anywhere

Roy Busdiecker
Micro Software Systems
P.O. Box 1442
Woodbridge, VA 22193

The Monitor program provided on tape to owners of PETs with the old ROMs occupies locations (in hex) \$0400 to \$076B, right where the PET stores BASIC programs! If you're only interested in working with 6502 machine language routines, that location for the Monitor poses no problem.

Unfortunately for me, I wanted to have the Monitor available at the same time as BASIC programs. Despite a variety of attempts, I was unable to find a combination that would allow me to enter and run BASIC programs while having the Monitor available in its original location.

On the other hand, if the Monitor could be moved somewhere very near the highest available memory location with which the PET is equipped, then the end-of-memory pointer could be reset to protect the Monitor. Then a BASIC program could be run, and it would not interfere with the Monitor.

My problem appeared to be solved when I found an article by Professor Harvey B. Herman of the University of North Carolina ("Move It", MICRO, September 1979). Although a critical figure seemed to be missing from the article, it was not too difficult to puzzle out, since the technique was based on an article by Jim Butterfield in the PET User Notes (Issue 1, Vol. 2). Incidentally, Jim has been a key figure in unravelling the secrets of the PET, both publishing information himself and pointing others in the right direction.

Although a relocation technique is summarized in this article, the discovery that got me excited was a simple but powerful extension to make it do many relocations, after the first one was completed.

Why would anyone want to relocate the Monitor to many different locations? The answer lies in the earlier observation that it would be desirable to locate it near the top end of available memory. With a 4k PET, a good location for the Monitor would be starting at the 3k location. On an 8k PET, you would want to locate it from 7k up. If a 4k PET had an 8k memory extension attached, giving a total of 12k, the Monitor should be located at the 11k point. Other combinations of PETs and external memories would lead us to want Monitors located at 15k, 19k, 23k, 27k and 31k.

With the approach described here, all of those Monitors can be created in little more time than it takes to SAVE each one.

First, we must create one working Monitor relocated to a position where it does not conflict with the original. Here's one way to do it:

1. LOAD the Monitor (Print STATUS; PEEK (630) to insure that the LOAD was good ...

PET should print 0 0). Rewind the tape.

2. Type SYS62894, then press RETURN. You will get the message PRESS PLAY ON CASSETTE #1. Insert the Monitor tape and press PLAY. The tape will run until the FOUND MONITOR message appears, then it will report READY. At this point the tape header has been found and loaded into locations 634 through 638, but the Monitor itself has not started loading. Here is the meaning of bytes 635 through 638.

635	636	637	638
lo byte	hi byte	lo byte	hi byte
First location that program tape will load into.		Last location that program tape will load into.	

3. By changing the values in these locations, we can make this second copy load into a different area of memory. For this exercise, let's put it into locations 3k (decimal 3072, hex 0C00) and up. To do that, POKE 636, 12:POKE 638,15:SYS 62403
The tape will run and PET will report LOADING until the Monitor is in. Rewind the tape and set it aside. At this point, you will have two identical copies of the Monitor. One is located from \$04000 to \$076A (\$ indicates a hex value), as shown in Figure 1. The other copy is in locations \$0C00 to \$0C6A (see Figure 2 for the first 128 locations). The second copy, of course, will not work because its addresses point to the wrong locations.
4. In order to make the \$0C00-0C6A copy of the Monitor usable, you must alter (patch) the contents of 84 memory locations. There are several ways to do this, but the straight-forward approach I used (outlined below) is about as easy as any other.
 - a. Type SYS 1039 and press RETURN. This transfers control to the \$0400-\$076B Monitor, which will display
PC SR AC XY YR SP
C6ED 30 33 39 00 FE
 - b. Consult Figure 1 to see which values are to be changed (the circled numbers). A circled value in line 0410 calls for a change in the corresponding position in line 0C10. Line 0500 corresponds to 0D10, 0600 to 0E00, and 0700 to

0F00. If the circled number is 04 in the original Monitor, that value in the copy should be changed to 0C. Likewise, 05 changes to 0D, 06 to 0E, and 07 to 0F. Figure 3 shows the first 128 locations in the copy after changes have been made.

- c. To make the changes, list a section of copy with the M command, as in M 0C00 0C7F

which prints the first 128 bytes in 16 rows. Next, use the cursor controls to position the cursor over the value to be changed, type the corrected value, and press RETURN. Even if several values in a line are changed, you only need to press RETURN once per line. Repeat the procedure until all 84 changes are made.

- d. For insurance, save a copy of your new 3k Monitor before testing it.

S 01,3K MONITOR 3087,0C00,0F6B is the command to use. To be on the safe side, make several copies on the tape. Rewind this tape, mark it "3k Monitor", and set it aside.

- 5. Now test your 3k Monitor, to make sure it works correctly. Type X, then RETURN to get out of the original Monitor. Type SYS 3087, then RETURN, to transfer control to the 3k Monitor. Try out the features described for the Monitor in your manual.

When you are confident that you have created a working Monitor at the 3k point, you are ready to make as many working copies in other locations as you have memory to accommodate. If you have a full 32k, you may use all the procedures below exactly as written. Otherwise, just delete (or ignore) references to locations beyond the end of your RAM. Here is the procedure:

1. LOAD the 3k Monitor. Rewind and remove the cassette.
2. Put the original Monitor tape in the cassette unit, and do step 2 of the earlier process.
3. POKE 636,28:POKE 638,31:SYS 62403. This puts a copy of the original Monitor in memory starting at 7168 (\$1C00).
4. POKE 135,12. This tells your PET that end-of-memory is just below 3k, so the BASIC program described below will not mess up your Monitor.
5. Type NEW and press RETURN. This is very important!
6. Type in and run the following program, which will create working copies of the Monitor at the high end of every 4k increment of memory.

MONITOR MULTIPLE RELOCATOR

```

10 REM MONITOR MULTIPLE RELOCATOR
20 REM COPYRIGHT NOV 1979 BY
30 REM ROY BUSDIECKER
40 REM MICRO SOFTWARE SYSTEMS
50 REM P.O. BOX 1442
60 REM WOODBRIDGE, VA 22193
70 REM ALL RIGHTS RESERVED
80 :
90 X=6
100 K=1024:M1=3072:M2=7168:K4=4*K
110 FORI=0T0875
120 C1=PEEK(M1+I):C2=PEEK(M2+I)
130 MM=0:IFC1<C2THENMM=1:NC=NC+1
140 FORJ=0T0X:POKEM2+I+J*K4,C1+MM*(J+1)*16:NEXTJ,I
150 PRINT"THESE WERE"NC"CHANGES."

```

In line 90, X = 6 sets the program for 32k memory. For each 4k less than 32k in your machine, subtract 1 (for a 16k machine, line 90 should be X = 2).

After the program has finished, you will have X + 1 new working copies of the Monitor. My PET took just under two minutes to do the computations for seven copies. Figure 4 shows the corresponding line from several copies of the Monitor before the run, while figure 5 shows them afterwards. Note the changes made by the program!

All you have to do now is to SAVE the new Monitors the same way you saved the 3k Monitor (step 4d of the first procedure). The table below gives the values to use in the SAVE command (use SYS 3087 to get into the Monitor), and the SYS numbers to use the other copies of the Monitor.

MONITOR LOCATIONS (for SAVE)

VERSION	START	END	SYS	POKE 135,
3k	0C00	0f6B	3087	12
7k	1C00	1F6B	7183	28
11k	2C00	2F6B	11279	44
15K	3C00	3F6B	15375	60
19k	4C00	4F6B	19471	76
23k	5C00	5F6B	23567	92
27k	6C00	6F6B	27663	108
31k	7C00	7F6B	31759	124

When you LOAD any one of the Monitors later on to use with BASIC programs, remember to POKE 135,___ with the number shown in the table, then do a NEW before LOADING or typing in your program.



Figure 1a. Monitor in original location, showing bytes to be changed (part1)



Figure 1b. Monitor in original location, showing bytes to be changed (part 2)



Figure 1c. Monitor in original location, showing bytes to be changed (part 3)



Figure 1d. Monitor in original location, showing bytes to be changed (part 4)



Figure 2. Copy of original monitor, moved to locations \$0C00 - \$0F6B.



Figure 3. Monitor in \$0C00 - \$0F6B, after corrections have been made.



Figure 4. Contents of selected locations before Monitor Multiple Relocator program is run.



Figure 5. Contents of selected locations after Monitor Multiple Relocator has been run.

ADDRESSES WHICH MUST BE MODIFIED

- List of memory addresses: 0C15 0C1A 0C49 0C50 0C61 0C73 0C76 0C79 0C86 0C91 0C95 0C9A 0CC1 0CC6 0CC9 0CD1 0CE0 0CE3 0D0A 0D0B 0D0C 0D0D 0D0E 0D0F 0D10 0D11 0D33 0D36 0D39 0D3E 0D49 0D50 0D53 0D56 0D59 0D5C 0D61 0D64 0D69 0D6C 0D6F 0D74 0D79 0D92 0D97 0D9E 0DA1 0DA4 0DA9 0DAE 0DB1 0DB4 0DB7 0DBC 0DBF 0DC4 0DC7 0DD0 0DD3 0DE5 0DEA 0E11 0E1A 0E21 0E39 0E51 0E58 0E64 0E6B 0E74 0E7D 0E80 0E9B 0E9E 0EA1 0EA6 0EB5 0EDF 0EF8 0F13 0F16 0F30 0F33 0F49

THERE ARE A TOTAL OF 84 ADDRESSES TO CHANGE

Figure 6. Addresses of individual bytes which must be altered to correct first copy of Monitor in \$0C00 - \$0F6B.

PET/CBM UNCRASHER™

WHAT IS IT? — UNCRASHER™ is a two button device that allows PET/CBM users to regain control of a cursor that's been lost due to programming errors. BASIC programs may be recovered. Machine language programs in the second cassette buffer are not disturbed either.

WHICH PETs/CBM's? — UNCRASHER™ is for all PET/CBM computers that use the "NEW" Version 2 ROMs. (Older model PETs should use the ITS NEW-CURSOR™.)

DOES IT WORK? — You bet!!! See the detailed review of the types of crashes and the concept of recovery in the first issue of Compute.

INSTALLATION — Simple, completely illustrated instructions using only a Phillips screwdriver ensure installation in minutes. No soldering or modifications to the computer.

OPERATION — Just follow the simple steps—push the buttons and reset the stack pointer—and PRESTO... recovery!

And all this happens without powering the PET/CBM down and up.

WHY UNCRASHER™? — No first class computer such as the PET/CBM should be without this capability. Whether your fancy be programming, business, education, or hobby, UNCRASHER™ saves you time by uncrashing your slip-ups.

AVAILABILITY — Now in better computer stores, or order direct from ITS, made by the people who brought you NEW-CURSOR™.

INTERNATIONAL TECHNICAL SYSTEMS INC. P.O. BOX 264 WOODBRIDGE, VIRGINIA 22194 CUSTOMER SERVICES - RICHMOND, VIRGINIA (804) 262-9709

\$14.95



PET Printer Adapter



McM's ADA 1400 drives a printer with an RS-232 interface from the Commodore PET IEEE-488 bus. The ADA 1400 is addressable, works with the Commodore disk and prints upper and lower case ASCII.

A PET IEEE type port is provided for daisy-chaining other devices.

A cassette tape is included with programs for plot routines, data formatting and screen dumps. The ADA 1400 sells for \$179.00 and includes a PET IEEE cable, RS-232 cable, power supply, case, instructions and software.

Order direct or contact your local computer store.

VISA AND M/C ACCEPTED—SEND ACCOUNT NUMBER, EXPIRATION DATE AND SIGN ORDER. ADD \$3 PER ORDER FOR SHIPPING & HANDLING—FOREIGN ORDERS ADD 10% FOR AIR POSTAGE.

CONNECTICUT microCOMPUTER, Inc. 150 POCONO ROAD BROOKFIELD, CONNECTICUT 06804 TEL: (203) 775-9659 TWX: 710-456-0052

CAUTION!

USE OF SOFTPAC-1 MAY BE HABIT FORMING

We would like to announce a NEW STANDARD in Software Packaging! With SOFTPAC-1 we are combining QUALITY software with BACK-UP COPIES on all serious programs. There is a sheet describing how to ADD SOUND to your PET or CBM for \$13! Some of the programs include SOUND in them. The Floppy version has a animated DEMO program which allows 1 key loading of any program of your choice. From the programs you can automatically return to the DEMO, to choose a different program! You get 18 Programs on Disc or 17 Programs on Cassette. The difference is you get TWO Discs or TWO Cassettes with the SAME programs for redundancy in PROTECTING YOUR Investment! A clear vinyl page holds the discs and cassettes. This all comes packaged in a Strikingly Silk-Screened, virtually indestructible NOTEBOOK! We Sincerely feel that you will be so impressed with the High Quality Software and package, that we are offering a 10 day Return Privilege! See disclaimer at bottom of Ad. This package will RETAIL in stores at \$34.95, but for a LIMITED time to COMPUTE READERS we will make the following offer:

**FOR \$29.95 + \$1 Shipping
YOU GET ALL THIS!**

Silk-Screened Notebook
Vinyl Pocket Page
18 PGMS on Master & Backup Discs!
or
17 PGMS on Master & Backup Cassettes!
18 Pages Text & PGM Listings!
First Class Delivery From Stock!
10 Day Money Back Return Privilege!
All Our Best Selling Software!

“SOFTPAC-1F” “01

“TANK-16K”	“DEMO”
“QUIZ MASTER DEMO”	“MEMORY TEST”
“QUIZ MASTER PGM”	“CHASE”
“BIORHYTHM”	“BREAKOUT”
“HOME UTIL.V4”	“OTHELLO”
“MPG”	“OTHELLO/2”
“LOANS 1 & 2”	“STRATEGY”
“ELECTRICITY”	“BOUNCE”
“SAVINGS”	“TANK”

Complete listings are provided for the “serious” programs.

These programs run in ALL PET/CBMs! We accept MASTERCARD & VISA. Send Account Number, Interbank Number, Expiration Date and SIGN your order. Please Specify FLOPPY DISC or CASSETTE Version, and which computer you own, and whether you have a Business or Graphics.

COMPETITIVE SOFTWARE
21650 MAPLE GLEN DR.
EDWARDSBURG MI 49112



IMMEDIATE REFUND minus Shipping upon receipt of package within 18 days of shipment. Enclose reason for return in package. Dealer Inquiries Invited.

PET PROGRAMS ON TAPE EXCHANGE

Gene Beals

Box 516
Montgomeryville, PA 18936

The "programs on tape" service and exchange functions as a low cost method for software distribution. The copying cost is \$1 per program. We can put up to 4 programs (8K) on a C-10 tape, or 12 on a C-30 tape. Please add \$1 per tape (either C-10 or C-30) to cover tape cost and postage within U.S. or Canada. If any written documentation is available, a copy will be included with the associated program.

If you have a program to contribute to the list (one which we don't have, or an updated or enhanced version of an existing program), please send it on tape. We will save it for the exchange and return a program of your choice.

Please write to me (Box 516, Montgomeryville, PA 18936) to request or exchange programs, or if you have any comments on the way the exchange is being conducted.

SPACE RACE - Matt Ganis -- guide your spaceship to the top of the box through randomly moving stars.

ACEY DEUCY - Matt Ganis -- you are dealt two cards and then bet whether your next card will be between the first two cards.

BOMBER - Matt Ganis -- destroy the city by dropping bombs on it. Lose points for each bomb and accumulate points for each hit.

MATH DRILL - William C. Anderson -- drill on addition, subtraction, multiplication, and division for numbers 1 through 12.

OPTI-STICKS -- combines optical illusions and graphics demo of sticks rolling down hill - nice demo.

TRACE-OLD ROM - Brett Butler -- self-relocating version

TRACE-NEW ROM - Brett Butler -- self-relocating version

LIFE 64*64 V.2 - Frank Covitz -- maintains symmetry through wrap around. Set for either growth or decay. Excellent machine language program.

FORCES - Everett Lumpkin -- Calculate resultant of vector forces

FORMAT - Elizabeth Deal -- PRINT USING subroutines w/rounding

HISTORY QUIZ - Dave Ray -- Simple CAI program

HORIZON COORD - R. Grockett Jr. -- Calculate altitudes/azimuths of celestial objects

INDEX BOTH - R. Wagner & Wilcox -- Index program modified for all roms

LAYOUT TECHNIQUE - Jill Johnson -- CAI teaches year-book design

NERVES - Ralph Bressler -- Game of guessing random time intervals

NEWMON ISNSTR-OLD - for 2.0ROMs Instructions for newmon program

PATTERNS - R. Grockett -- Screen flashes & cb2 beeps

PARTS OF SPEECH - Laurie Birtalan -- for 2.0 ROMs CAI grammar quiz-WAIT statement used

ACCOUNTING CAI - Janice Klages -- Simple quiz/tutor

BASEBALL TRIVIA - Amy Druschel -- Simple team name-city matching CAI

BIOCOMPAT - Joe Cannata -- Tests bi)orhythm compatibility

BLACK IV - Andy Finkel -- Updated blackjack-Vegas rules Uses up to 4 decks

CASCADE - Ralph Bressler -- Nice graphic bead dropping demo.

CIRCLE - Solves Josephus circle problems

COMPUTER HISTORY - Dave Ray -- CAI quiz on the history of computers

DIAMOND LANE - Brent Weaver -- Great video game-don't hit the maniac.

DIGIT SPAN - Ralph Bressler -- Number sequence memory test.

FLASH - Ralph Bressler -- High-speed word memory test

INDEX - David Wilcox -- for 2.0 ROMs Tape program high-speed indexing program

PARTS OF SPEECH - Laurie Birtalan -- CAI grammar quic

PCKBK - Vanderpool -- Very simple checkbook balancing program

READING TEST - Mariann McElwain -- CAI test of your comprehension

RETURN - Andy Finkel -- Keyboard dexterity reduced to simplest level.

SCREENPRINT PR40 - John Lemkelde -- Screendump for SWTPC PR40 printer

SEA QUIZ - Jackie Bober -- CAI teaches you about the sea

SUPER MASTERMIND - David C. Swaim II -- New improved version of logic game

SUPERMON REL. - Wozniak, Baum, Butterfield -- 3.0 ROMs Relocatable advanced machine language monitor

SUPERMON INSTR'S - Wozniak, Baum, Butterfield -- for 3.0 ROMs How to run supermon

TRACE-NEW - for 3.0 ROMs Trace routine for new ROMs

UNIV. ROM TEST - Jim Butterfield -- Tests out the PET's ROM chips

VOCABULARY - Everett Lumpkin -- Have the PET teach you Latin words

INTELLECTUS - General knowledge college level quiz

MP MATH - Does multiple precision arithmetic operations up to approximately 40 digits or more. Uses machine language

FN MACHINE - Number enters function machine, levers turn, lights flash, a new number appears. Next time enter new number and predict what will appear by determining mathematical function

PIZZA-GRADE 3 - modified by Elizabeth Deal -- Well written quiz program for pre-schoolers. Must give directions over cb radio to pizza truck

Some Exchange guidelines:

1. The Exchange is intended to promote the sharing of user generated software.
2. Be very careful that you submit only your own, original work to the exchange. Matters of copyright remain the sole responsibility of the individuals submitting the program. We accept no liability, express or implied. Do not submit modified (or unmodified) commercial software to the Exchange. It makes their job much harder. We make every effort to screen software; we will appreciate our readers' efforts to do the same.
3. We do not intend to promote the Exchange as a competitor to commercially available software. You'll find that commercial software is generally much more polished and documented than what you'll receive from us.

Robert Lock

Capute

Wherein we acknowledge recent goofs. . .

This page brought to you by Robert Lock, Editor/Publisher and our (sometimes hostile) but always active readers.

It seems appropriate, on this sackcloth and ashes page, to start with a new resolution: I promise to try to avoid continuation articles of the type used last issue. Charlie McCarthy's CHEEP PRINT software is in this issue. Phew. Your comments and letters are hereby officially acknowledged. Ouch. I won't do it anymore. Groan.

Perhaps the biggest blooper in Issue 3 was the accidental deletion of the last part of an OSI software listing. I can report, with some conviction, that the article was read by OSI owners. The corrected listing was printed in Issue #1 of compute II.

Corrections to Issue 3:

Utinsel, page 36.

The program line 780 printed as
780 POKE J,BL:J = J + 1
should read

780 POKE J,B1:J = J + 1

The Learning Lab, pages 52-53.

The copyright symbol shows up in various places in the listing. It should be the up-arrow (exponentiation) symbol instead.

We'll keep you posted in the unlikely event that more errors surface. ©

Program Listings for COMPUTE

Cursor control characters will appear in source listings as shown below:

h=HOME , ĥ=CLEAR SCREEN
 ↓=DOWN CURSOR , ↑=UP CURSOR
 →=RIGHT CURSOR, ←=LEFT CURSOR
 ⤵=REVERSE , ⤴=REVERSE OFF

Graphics (i.e. shifted) characters will appear as the unshifted alphanumeric character with an underline. This does not apply to the cursor control characters. The Spinwriter thimble doesn't have a backarrow symbol, so a "˘" is used instead.

The "˘" is used to indicate the beginning of a continuation line. It is also used to indicate the end of a line which ends with a space. This prevents any spaces from being hidden. ©

PET Word Processor

8K
and
16/32K
PET
versions



This program permits composing and printing letters, flyers, advertisements, manuscripts, etc., using the COMMODORE PET and a printer.

Printing directives include line length, line spacing, left margin, centering and skip. Edit commands allow you to insert lines, delete lines, move lines and paragraphs, change strings, save files onto and load files from cassette (can be modified for disk), move up, move down, print and type.

Added features for the 16/32K version include disk and cassette support written in, string search for editing, keyboard entry during printing for letter salutations, justification, multiple printing, pagination, tabbing, paragraphing, and more.

A thirty page instruction manual is included.

The CmC Word Processor Program for the 8K PET is \$29.50. The 16/32K version is \$39.50.

Order direct or contact your local computer store.

VISA AND M/C ACCEPTED - SEND ACCOUNT NUMBER, EXPIRATION DATE AND SIGN ORDER. ADD \$3 PER ORDER FOR SHIPPING & HANDLING - FOREIGN ORDERS ADD 10% FOR AIR POSTAGE.

CONNECTICUT microCOMPUTER, Inc.
 150 POCONO ROAD
 BROOKFIELD, CONNECTICUT 06804
 TEL: (203) 775-9659 TWX: 710-456-0052

Finally, MAE — A PET DISK-Based MACRO ASSEMBLER/TEXT EDITOR

Works with 32K PET

- Works with 2040 Disk, and can drive 2022/2023 Printer, and/or RS232/20 ma Device thru User Port.
- 100% Disk Based, 100% Machine Language.
- Macros, Conditional Assembly, and a new feature we developed called Interactive Assembly.
- Coexists with Basic, Auto character repeat, Sorted Symbol Table.
- 27 Commands, 26 Pseudo Ops, 5 Conditional Ops, 38 Error Codes.
- Creates relocatable object code on disk.
- Assemble from Memory or Disk.
- String search, search and replace, and inter-line edit.
- Auto line # -ing, move, copy, delete, renumber.
- Labels up to 31 characters — user specifies length.
- Includes extension to PET monitor (disassemble, trace, etc.), Library of PET ROM locations, Relocating Loader, plus more.

Manual, Diskette, U. S. postage — \$169.95
 (Requires completion of License Agreement —
 Write for details)

Eastern House Software

3239 Linda Drive

Winston-Salem, N. C. 27106

- Please enter my 1 year (6 issue) subscription to COMPUTE.
 Please enter my 1 year (6 issue) subscription to compute II.

My computer is: PET _____ APPLE _____ ATARI _____ OSI _____ SYM _____ KIM _____
 AIM _____ Other _____ (Specify) _____

Check One:

_____ \$9.00 (U.S. Mail Order Subscription)

_____ \$12.00 U.S. (Canadian Subscription)

- I want Both!

_____ \$15.00 (U.S. Mail Order Subscription)

_____ \$18.00 U.S. (Canadian Subscription)

My Name, Address: _____

Charge my Visa _____ MC _____

Number _____ Expires ____/____/____

COMPUTE and compute II are publications of Small System Services, Inc., 900-902 Spring Garden St., Greensboro, N.C. 27403 919-272-4867

The Editor's Feedback:

My computer is _____ PET/CBM _____ ATARI _____ APPLE _____ OTHER

My application is (check all that apply):

_____ Home/Personal _____ Business _____ Educational

_____ Industrial _____ Other

Comments:

New Product - Z-80 Softcard _____

Others? _____

Content:

Best Article This Issue (page #, title)

I'd like to see more _____
 articles in COMPUTE.

I'd like to see fewer _____
 articles in COMPUTE.

Other suggestions:

COMPUTE'S BOOK CORNER

Best of The PET Gazette

\$10.00

Collected PET User Notes

Volume 1, Issues 2 - 7

\$9.00

Volume 2, Issue 1

\$1.50

All 7 issues \$10.00

My Name, Address:

Charge my Visa _____ MC _____

Number _____

Expires ____/____/____

**Back issues, when available, \$2.00 each.
 Issue 1, not presently available.**

Add \$2.00 shipping & handling

Place
Stamp
Here

COMPUTE./compute II
Post Office Box 5406
Greensboro, NC 27403

Place
Stamp
Here

COMPUTE./compute II
Post Office Box 5406
Greensboro, NC 27403

Place
Stamp
Here

COMPUTE./compute II
Post Office Box 5406
Greensboro, NC 27403

Dear MICRO-ED:
I would like further information on
your educational programs

Name _____

Address _____

City _____ State _____ Zip _____

PLACE
STAMP
HERE

MICRO-ED, INC.
P.O. Box 24156
Minneapolis, MN 55424



**PET-AIM
KIM-SYM**

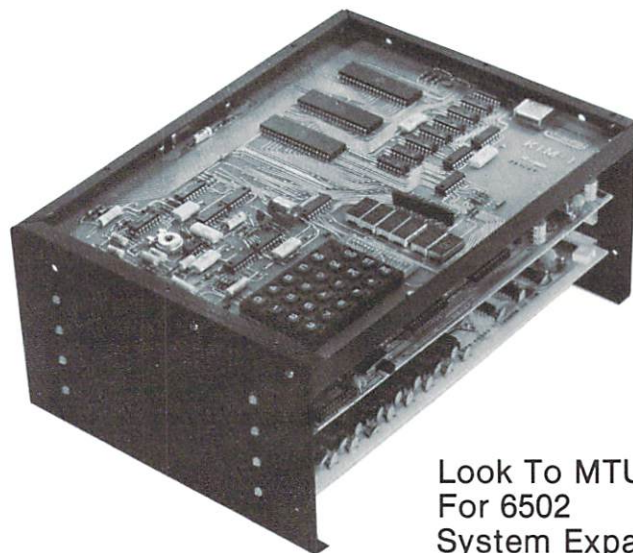

Look To MTU
For 6502
System Expansion



Micro Technology Unlimited

P.O. Box 4596, 841 Galaxy Way
Manchester, N.H. 03108
603-627-1464

Call Or Write For Our Full Line Catalog

The Great American Solution Machine.

More than 50,000 students, teachers and administrators solve problems with this reliable Commodore computer.

You're looking at the Number One computer in education today.

In fact, you've probably already used it.

The Commodore.

You know it teaches.

Guides. Challenges.

Analyzes. Organizes.

Simplifies.

But did you know it has capabilities that are far beyond its price range?

You can accomplish tasks with The Commodore at a price/performance ratio that leads the field.

You can also count on The Commodore showing up for class every day.

It's a remarkably sophisticated, remarkably reliable machine. Around the world in

schools—and businesses too—there are more than 100,000 Commodore computers now at work.

If you sense a snag in the flow of knowledge in your classes, we think you should challenge The Commodore.

Compare it against any computer in—or above—its field.

See if it won't raise the level of interest and accomplishment among your students.

And simplify the complex in your administrative duties.

All at a price that makes it stand alone.

For the name of your nearest authorized Commodore dealer, just write to: Commodore Business Machines, Inc., 3330 Scott Blvd., Santa Clara, CA 95051

Call now toll-free. Ask for operator 973:

800-824-7888

(In Calif., 800-852-7777)

(In Alaska and Hawaii, 800-824-7919)

 **commodore**

COMMODORE

