



NEXT MEETING OF
THE GLENSIDE COLOR COMPUTER CLUB

Thursday, February 11, 1987 - 7:30pm
GLENSIDE PUBLIC LIBRARY
25W. Fullerton Avenue
Glendale Heights, IL.

DIRECTIONS: Glendale Heights is located between Glen Ellyn & Wheaton, IL and Bloomingdale, IL. Fullerton Ave. is West of Bloomingdale Road in Glendale Heights. The Library is about a half a mile down West Fullerton on the Left side from Bloomingdale Road. The meetings are open to all TRS-80 Color Computer 1, 2 & 3 users and owners.

FEBRUARY NEWSLETTER

If I have not wished you a Happy New Year, let me do it now;

HAPPY NEW YEAR!

Here is hoping that 1988 brings to you and your family all the health and prosperity the good lord can give.

In keeping with our promises in last months newsletter, we will be outlining some of the Club's objectives for the coming year. This will be the goals of the club and by no means are they etched in stone. In order for us to grow as a club, planning out objectives is a benchmark, a gauge if you will, to strive for during the coming year. Without planned and well thought out objectives, there is nothing to shoot for but yesterday. So lets get down to business and list some of our 1988 key goals.

1) The number one club objective for 1988 will be to again host the Chicago RAINBOWfest. The benefits we gained from last years event is still being felt. Club exposure and recognition along with the new members we get from this one event far and exceed anything that we say, do, write or build.

GOOD NEWS: We can put this objective into the can for another year. On January 15th, I spoke with Ira Barsky of Rainbow and he informed me that we have been selected to host the '88 Chicago RAINBOWfest. We will be detailing this at the February meeting.

2) The number two club objective for 1988 is new members. It goes without saying (but I'll say it anyways) the existing members are the corner stone of the club. However, with out new members, nothing can be build off of that corner stone! We closed out 1987 with 39 new members, so it should not be too hard to repeat this number +1.

Continued on next page

INSIDE CO CO ~123

- o A \$4.51 DELUXE JOYSTICK
- o TANDY'S HI-RES JOYSTICK INTERFACE MODIFICATION
- o ONE TANDY CENTER

THE GLENSIDE COLOR COMPUTER CLUB
OFFICERS

- PRESIDENT.....Ed Hathaway
462-0694
- VICE PRESIDENTS ELECT.....Rich Ekstrom
885-2573
- Len Zielinski
976-8791
- SECRETARY/TREASURE.....Greg Pietrucha
830-1855
- VICE PRESIDENTS, BBS.....Dave Barnes
307-1516
- Dave Lucas
478-1398

GLENSIDE BULLETIN BOARDS

- CHICAGO.....(312) 463-8932
- ROSELLE.....Down for Repairs

3) The number three club objective for 1988 will be the CoCo II. This may seem a little strange to have as an objective, but not really. In reviewing last years club presentations, it was clear that most of them centered around the CoCo III. This was fine because the CoCo III is still a rather new system. BUT according to our records, that majority of you still have the CoCo I or II as your only computer. So more attention will be placed on the CoCo II in 1988. Yes, the future for the Color Computer is with the CoCo III, yet me must always remember this one key statement; "Today is now, but it was yesterday that got us here..."

4) The number four club objective for 1988 will be Club Socials. With the size of Glenside it is somewhat surprising that we do not have more social activities then we do. How does a pizza night sound? Or maybe an old fashion barbecue cook out. At our monthly meetings there is just not enough time for everyone to talk to one another one-on-one. These socials would afford us this opportunity and to get to know each other that much better. These planned events would be for the WHOLE family. Not just us Byte Heads!

5) The number five club objective for 1988 is communications. We currently do a good job along these lines with the newsletter and the Club BBS, but it could and should be better. One of these areas would be to make up a membership directory. Not just a listing of your 'name, address and phone number' but something a little more involved. Something that says something about you, your family and your computer habits. We will be working on this one as a total club project in the coming months.

The above goals should get Glenside and 1988 started and keep us busy for a few months anyways. If you think of something that might fit as a club goal, let us know. All of the above were products of you letting us know what you wanted and how you wanted it.

Since we are well into the annual Mid-West deep freeze, inside this issue of CoCo-1 2 3 are a few hardware projects to warm up your 'CoCo Lov'en Hearts'. One project was provided by Dave Lucas that converts an IBM PCjr Deluxe Joystick to work on the CoCo. The best part of this hardware project is the cost. Following the article outline you

will be able to put together a Super Deluxe Joystick for about \$14! The other hardware modification project was put together by Dave Barnes. With help from Delphi and Logan Ward of the Memphis Color Computer Club, inside is a detailed design and outline in converting your Tandy High-Res Joysti Interface to work with either ColorMax or CoCoMax III. This project is a little more involved then the joystick modification but will save you a great deal of money if you were to buy it already done. If my math is correct, this modification would save you about 65% by doing it yourself!

There you have it, Club objectives for 1988, good news from Rainbow, a few hardware projects and so much more all in one Glenside publication. Who could ask for more! See you all at the February meeting.

SALE

Tandy 128K Model 4

Comes complete with 2
single sided disk drives,
printer cables and a
wide assortment of
software (VisiCalc, Desk-
Mate, Pascal, Profiles).

Call Ron Steinberg
at (312) 307-0486

\$400.00

* NOTICE: Materials contained herein may be reproduced in whole or in part unless otherwise indicated. Please quote source as
GLENDSIDE COLOR COMPUTER CLUB of ILLINOIS

Editor: Ed Hathaway
Contributing Writers: Floyd

Tony Podraza
David Barnes
Dave Lucas

Graphics & Designs: Second City Software
Staff Artist Thomas Cassell (c)

Glenside Color Computer Club's CoCo-1 2 3 is published monthly. Subscriptions to non-members are available for an annual fee of \$12. Make checks or money orders payable to Edwin C. Hathaway, and mail to 8W. Stevenson Dr. Glendale Hts., IL 60139. All subscriptions will begin with the next available issue.

A \$14.31 DELUXE JOYSTICK?

By: Dave Lucas

Has your Tandy Deluxe Joystick shot down it's last Space Invador? Are you saving up your nickles and dimes to buy a new one? Well don't! At \$29.95 plus tax, Tandy's Deluxe Joystick is really to expensive to be replacing every time you conquer the universe. A few weeks ago I was looking through the December issue of Computer Shopper and on page 232 there was an ad from Mendelson Electronics, Inc. In this ad they are selling an IBM PCjr joystick that looked just like the one that Tandy sells. The big difference was the price, \$10.00 plus \$2.50 for shipping and handling. Having saved up about \$10 worth of loose change I ordered one in hopes that it would work on my CoCo.

No sooner had it arrived, I had it apart comparing it to Tandy's. Much to my pleasant surprise the inside wiring was almost identical. The only real noticeable difference was the 9 pin connector IBM uses to plug this joystick into the PCjr. After doing some experimental wiring, I came up with the right combination and was able to get this \$10 joystick working on my CoCo.

In this article, I have provided for you the before and after wiring designs. Figure #A is how the IBM PCjc joystick looks like

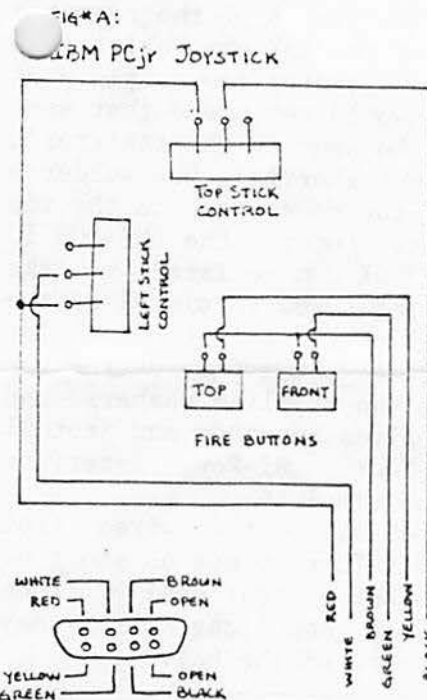

wiring change needed to be made. This involves relocating the RED wire inside the joystick from pins #1 of the joystick controls to pins #3 (currently not used). of the rest of the wires (BLACK, WHITE, GREEN, BROWN & YELLOW) remain as is. After relocating the RED wire, take a piece of

out of the box. Figure #B is the wiring designs you will need to perform to convert it over to the CoCo. You will only need to buy a 6 pin DIN plug (Cat# 274-020) from Radio Shack costing you all of \$1.69 plus tax. Or if your old Tandy Deluxe Joystick is beyond repair, you could take that DIN plug and use it.

For the most part there is only one major

wire and extend the BROWN wire from the TOP FIRE BUTTON over to where the RED wire use to be on pins #1 of the joystick controls. After you have done this, cut off the 9 pin connector at the end of the cable the would plug into the PCjr. Wire up the 6 pin DIN plug you bought as shown in Figure #B. Close up the box, plug it into your CoCo and get back to saving the world for all mankind!

Here is the price breakdown and the savings you will have by doing this really minor conversion yourself;

RS DELUX JOYSTICK
CAT#26-3012

\$29.95+7% TAX=
\$32.05

* IBM-PCjr JOYSTK
from Mendelson
Part #220-500
\$10.00+\$2.50 S/H+
\$1.81 DIN plug=
\$14.31!

By buying mail order and making a few changes you save \$17.74! This is 55% off of the Tandy Deluxe Joystick price. With this kind of \$\$ savings you could get two and still not spend more then the cost of one from Radio Shack... If you are interested in buying these PCjr joysticks, Mendelson Electronics, Inc is located in Ohio and even the phone call is free, 1-800-442-3525. They take all major credit cards and/or personal checks (allow two weeks for check to clear).

FIG. # B : CONVERTED TO CoCo, TWO BUTTON (DELUXE) JOYSTICK

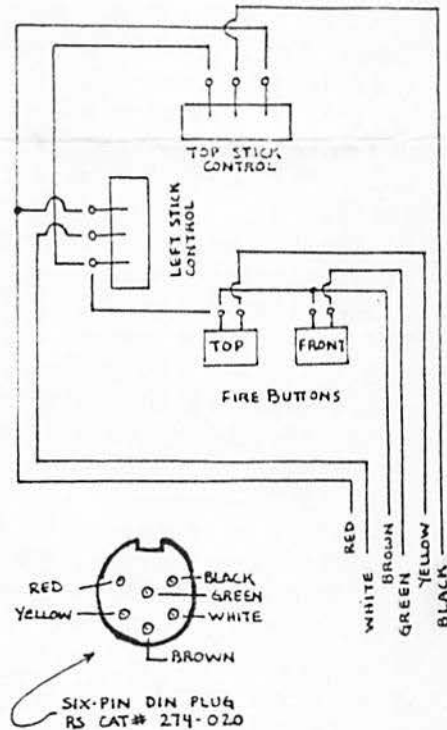

Dave Lucas is SysOp of Glenside's Chicago BBS (463-8932) and Co-Vice President of Telecommunications.



SWITCHABLE HI-RES JOYSTICK INTERFACE

By David W. Barnes

DISCLAIMER: The following modification to the Hi-Res Joystick interface is intended for legitimate owners of CoCo Max III. It is NOT intended for 'pirated' use of a non-purchased program. The Glenside Color Computer Club assumes no responsibility as to how this modification will be used.

This hardware hacking project originally appeared in PMODE 4, the official publication of the Memphis Color Computer Club. The project was originally done by Logan Ward and is reprinted with his permission.

EDITORS NOTE: Dave Barnes re-worked the design and text in order to help simplify this project for you.

Tired of plugging and unplugging your two separate Hi-Res interfaces to accommodate Color Max and CoCo Max III !!! If so, the following 'do-it-yourself' switchable Hi-Res Pac modification article should be of interest to you.

The first thing you will want to do is to acquire the necessary parts to complete the job. A fast trip to Radio Shack and your local electronics shop should supply you with everything you will need to finish this project.

PART LIST -----

- 1 - 15K ohm resistor (RS #271-1337)
- 1 - 560K ohm resistor (not available at RS)
- 1 - 3PDT switch (RS #275-681)
- 1 foot of #22 gauge wire

The next thing you will want to do, is determine where you want the switch to go. There isn't too much room to be fussy here. There are only two logical places that I could see, the top or the side of the unit. I chose to use

the top of the Hi-Res interface for placement of my switch. If you would like placement on the top also, place the unit with the top upward and the cassette and joystick connectors extending to the right. Measure from the left side of the Hi-Res exactly $1 \frac{3}{16}$ " and place a mark there. Now measure exactly $\frac{9}{16}$ " from the bottom of the unit and place another mark. The two marks will provide you with a center point from which you may now drill your hole. The two

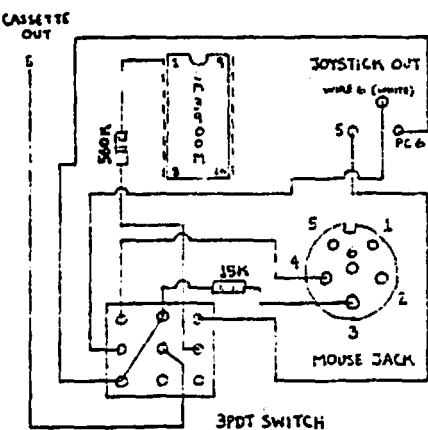

marks should be very close to the 'N' in the Tandy logo. Remove the four screws and separate the two halves. Drill your hole at the marked spot and place the top aside.

Locate and differentiate the cassette and the joystick connectors, the joystick uses a 6 pin DIN plug while the cassette uses a 5 pin DIN. Looking at the bare unit with the wires extending forward and the mouse jack towards you, the cassette feeds into the left side of the unit and the joystick comes through on the right. The trace from pin 6 of the mouse jack needs to be split. Logan recommended to cut the trace, however, I feel that the best thing to do here is to follow the trace to the joystick wire and then de-solder the wire from that point. It should be a white wire marked on the PC board by a number 6. Solder a piece of your wire to the spot where you just removed the white wire from. Holding the switch so that it toggles on/off from top to bottom, rather than side to side, connect the wire that was originally connected to the PC board to bottom lug of the left row. Now connect the newly soldered wire from the PC to the center lug of that same row. Solder a wire from the bottom lug to the top lug of the center row. Solder a wire from the top lug of the left row to pin 4 of the mouse jack. Now solder a wire from the middle lug of the center row to wire 5 of the cassette feed in. Now solder the 15K ohm resistor to the top lug of the center row to pin 3 of the mouse jack. I would recommend that some type of insulation be used on the resistor's bare wires to prevent shorting. Now solder a wire from pin 5 of the mouse jack to the top lug on the right. Locate the LM3900N IC chip. Solder the 560K ohm resistor to the middle lug on the right row to pin #1 of the LM3900N. Test all of the solder points for proper bonds. Install the switch on the top cover, without the two supplied washers, and gently press the halves together and install the screws. Your Hi-Res interface modification is now complete.

Helpful hint: Keep all of the wires from the switch to the solder points as short as possible, there is not a great deal of room inside the Hi-Res, and long wires may prevent proper fitting of the halves.

David Barnes is a self-employed contractor for major department stores. His hobbies are bass fishing, hand-gunning, and Color Computing. He is Vice President of the Glenside Color Computer Club and President of the Illinois Color Computer of Elgin.

ONE TANDY CENTER

By: Ed Hathaway

In reviewing last months ONE TANDY CENTER column, you could almost see the hand writing on the walls. The very week we went to press with this article, Tandy was releasing to retail most if not all of their new CoCo III software that I was calling 'Missing In Action'. It's ironic that this was the third time we ran an article zinging Tandy for their product delays only to find it available at their stores when we went to press. Either we have to step up the release date of our articles or maybe, just maybe, Tandy has placed a spy among us! A cretin among cretins, a shill personified lurking about the halls of the library recording our every word! When this leech gathers enough information he then reports his findings back to B.O.T. (Boys of Tandy) who conduct this covert operation from Billy Bob's Dew Drop Inn in Texas.

Each evening B.O.T. receives invaluable data from their outpost agents while swelling on a few Lone Star brewskes. Using Spectaculator (RomPac version of course), a complete data analysis is done from 'What If' to 'Who Cares'. The out come of all this activity is then compiled and presented to Marketing where they run it up the pole, salute it, wave it past Promotions, check it out with the Legal Eagles and then have their warehouse release it to retail. All this is done (or so it seems) just before our newsletter hits the street. It is indeed truly amazing!

Now that this ever elusive software is available, lets look at it from an 'end users' point of view. NOTE: Along side of the programs name we have used a star type rating (much like the movie critics use when reviewing a movie). However, since this is a daisy wheel printer we will use the '*' as our star(s). For this review a five stars rating will indicate that the program is the 'best of the best'. If a program receives a two star or less rating, 'buyer beware'. The basis of our rating is simple; The program(s) that provide the 'Biggest Bang for the Buck' will receive the higher number of stars. In all fairness, the program listings are in alphabetical order.

CAVE WALKER \$24.95: OS9 Level Two arcade game. Uses PMode4 graphics that supports a Composite or an RGB monitor. RATING: ***

THE COLOR COMPUTER ARTIST \$29.95: OS9 Level Two graphics picture editor. User-friendly

pull down icon menus for limited keyboard use. Supports a Composite or an RGB monitor. RATING: *

DESKMATE 3 \$99.95: OS9 Level Two integrated package of seven commonly used personal applications. Features pull down and point and click icon menus. Supports a Composite or an RGB monitor with switchable 40/80 column display in text. RATING: ****

DONALD DUCK'S PLAYGROUND \$34.95: A child development program for recognizing and matching shapes, colors and letters. RATING: ****

FLIGHT SIMULATOR II \$34.95: OS9 Level Two simulator of a Piper Cherokee plane. 3D graphics provide for the look and feel of real flight. Supports joystick and/or keyboard controls and a Composite or an RGB monitor. RATING: *****

HOME PUBLISHER \$39.95: OS9 Level Two 'print shop' or 'newsroom' type program. Features pull down and point and click menus. Can configure to 128K or 512K of memory. Supports a Composite or an RGB monitor. RATING: **

KORONIS RIFT \$29.95: OS9 Level Two arcade type game with 3D graphic effects. Requires keyboard and joystick user input and supports a Composite or an RGB monitor. RATING: ****

MICROSCOPIC MISSION \$29.95: OS9 Level Two arcade/simulation type program. Probe through the human body as a Microscopic Surgeon (MSS) to save your patient's life. Supports joystick or keyboard controls and a Composite or an RGB monitor. RATING: ***

MULTI-VUE \$49.95: A user-friendly graphics interface for OS9 Level Two programs. Will allow you to custom design your very own DeskMate type environment using Tandy and non-Tandy OS9 software. Features pull down and point and click icon menus. Supports a Composite or an RGB monitor with 32/40/80 column screens. Requires the OS9 Level Two Operating System to configure. RATING: ***

OS9 LEVEL TWO DEVELOPMENT SYSTEM \$99.95: A complete 'tool box' of applications, specialty input/output drivers and an editor assembler. Requires the OS9 Level Two Operating System. RATING: *****

OS9 LEVEL TWO OPERATING SYSTEM \$79.95:

Unleashes the full potential of your CoCo 3. Allows for multitasking operations at twice the speed as Level One. Supports 512K, Composite, Monochrome or an RGB monitor and BASIC-09 is included. RATING: *****

PHANTOMGRAPH \$39.95: OS9 Level Two business program that turns numerical data into graphs and charts. Expects data from software or user input. Pull down point and click menus, supports 128K, 512K, Composite, Monochrome or an RGB monitor. RATING: ****

RESCUE ON FRACTALUS \$29.95: OS9 Level Two arcade type game with 3D graphic effects. Requires keyboard and joystick user input and supports a Composite or an RGB monitor. RATING: ****

ROGUE \$29.95: OS9 Level Two arcade type game with 3D graphic effects. Requires joystick and supports a Composite or an RGB monitor. RATING: *

SHANGHAI \$24.95: RomPac strategy game based on a 3,000 year old game called Mah Jongg. Requires 128K and supports a Composite or an RGB monitor. RATING: ***

SUB BATTLE SIMULATOR \$29.95: OS9 Level Two simulator/strategy type game/adventure. Command either a U.S. Navy Subs or German U-Boats in graphic detailed realistic war simulation. Requires keyboard and joystick user input and supports Composite or an RGB monitor. RATING: *****

THEXDER \$24.95: RomPac shoot'em up arcade type game. Requires either keyboard or joystick user input and supports Composite or an RGB monitor. RATING: ****

WHERE IN THE WORLD IS CARMEN SANDIEGO \$34.95 OS9 Level Two graphic adventure game. Requires either keyboard or joystick user input and supports a Composite or RGB monitor. Software package comes complete with a World Almanac. RATING: *****

WINNIE THE POOH \$34.95: A child development program that enhances their map skills, reading ability and logical thinking. RATING: ****

ZONE RUNNER \$29.95: OS9 Level Two shoot'em up arcade type game. Supports a Composite or an RGB monitor. RATING: *

As we were putting this article together, the program Springster just became

available. None of the reviewers had the opportunity to look at this program for this column. In the months to come, we will be doing a more detail review on each of the above programs. At such time we will outline the program and explain why we took the position we did on rating these programs. If you take exception to the way we rated a particular program or would like to do a review of any CoCo software, please let us know. THIS IS YOUR NEWSLETTER!

JANUARY MEETING REVIEW

For all of you that missed the January meeting, you missed a good one! Club member Mike Kundsén pulled out all the stops in bringing you a most detailed presentation on music hardware and music generating software for the Color Computer. It was without a doubt one of the finest demonstrations Glenside has had the privilege to host. Mike, if I said it once I'll say it a hundred times more, THANKS FOR A SUPER SHOW!

Rust assure that if you missed Mike's performance this time we WILL have him back for a return engagement... BRAVO - BRAVO

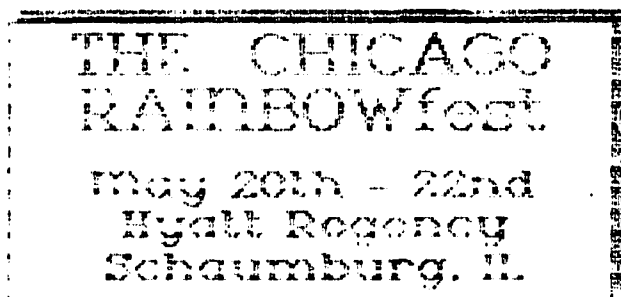

FEBRUARY MEETING REVIEW

For this month's meeting Tony Nowakowski and Dave Barnes will be demonstrating the new Graphic Interface for the OS9 Operating System called, Multi-Vue. Since Tandy is touting Multi-Vue in their '88 Catalog as *user-friendly*, we have asked both Tony and Dave to tell it like it is. We all have either seen or were told just how powerful yet hard OS9 is to use and learn. If in fact Multi-Vue can tame this operating system, then I know a lot of us will be all ears come February.

Special notice to all of you non-OS9 users; DON'T SKIP THIS MEETING JUST BECAUSE SOMETHING OS9 WILL BE DISCUSSED. Multi-Vue is being advertised towards you, the end user of the Color Computer 3. If in fact it is as *user-friendly* as Tandy claims, then it could be that missing link between you and OS9.

THE MINDMASTER'S DOMAIN B.B.S.

(A GLENSIDE SUPPORTED BBS)

SYSOP - DAVID LUCAS

(312)463-8932 300/1200 BAUD 24 HOURS A DAY

First of all I would like to thank David Barnes, Ed Hathaway & Bill Buklis for helping me out with the BBS, now that the credits are done and over with we can get down to business. When you call the BBS you will get a carrier. When you hear this you give an originate signal to my modem. After you connect, you press your enter key twice. Then if you haven't already logged on before you type new. It will then ask you for your name. After entering your name it will move you to the application file in which you enter your correct address, city, state, zip & telephone number. If you do not give correct information you will not receive access to my BBS. Now its time to get a password. The BBS will ask you to pick a three letter password, It takes your password and adds it to a three letter number. The three numbers and the three letter word you chose will form the six character password. Please write this password down & keep it to yourself you are responsible for any messages left under your name. Now that we are through the log on part, we can get down to explaining the BBS. After you enter your password it will go to a new user message telling you the policy of BBS. Once done with that it will do a mail check, this will tell you if you have any new messages and will display them then.next, you will go to the main menu. Here is where you get to choose what you want to do. Below is a copy of my BBS main menu. Now I will explain the BBS commands.

THE MINDMASTER'S DOMAIN TOP MENU ?=HELP

- | | |
|-----------------|-----------------|
| Time: | Online: |
| Min. left | |
| (A)DVERTISE | (C)HAT W. SYSOP |
| (D)EPARTMENTS | (E)XIT BBS |
| (G)AMES | (I)NFORMATION |
| (L)EAVE MESSAGE | (N)AMES |
| | (P)ARAMETERS |
| (H)IGH SCORE | (R)EAD MESSAGE |
| (S)URVEY | (U)PLOAD |
| (Y) NEW MAIL | (Q)UICK EXIT |
| (M)AIL STATUS | (?)HELP |
| (X)PERT MODE | (#)READ CLUB |

(A)dvertise: In this section you are allowed to place an ad free of charge For instance if you have a car or software or anything else you may want to sale. Also please leave a phone number, since all want ads are also posted on the Motorola BBS.

(C)hat w. sysop: Here is where you can get a hold of me if you need help. If I'm not home the chat mode will not page and it will ask you to leave me a message. This way you

won't waste time waiting for it to finish paging me.

(E)xit BBS: This is the way you are suppose to exit this BBS.

(G)ames: This section has a online game. It has a built in timer so you wont hog the BBS all night. It also keeps you from wasting all your time in one section of the BBS.

(I)nformation: This file will tell you about the Colorama BBS. It will also explain a in more detail about the BBS's functions.

(L)ease message: This is where you can leave E-Mail to another person on the BBS. Also you are allowed 10 lines per message & 63 characters per line. If your message is longer than 10 lines the BBS will let you continue your message.

(N)ames: This is where you can find out who else is on the BBS.

(P)arameter: This will let you change your line feed, characters per line, have the BBS slow down, turn the echo on/off and change to and from (X)pert mode.

(H)igh score: This is where you see your score you receive from the online game.

(R)ead message: Here is where you can read your message & all open messages. Also when you read a message left to you please delete it. So it will conserve on disk room.

(S)urvey: Here is where you can leave your comment to all about the BBS.

(U)pload: This is where most of the download will come from. Follow the prompts it gives you,when asked for the file name, enter the name of the file (8 character max.) and do not put an extension down, it does this for you. NOTE: Use (P)rompted upload for non-xmodem uploads, (A)SCII for ASCII files, (B)inary for compressed basic (files not saved in ASCII) files and (M)L for machine language or picture files.

(Y) New mail: Displays any unread messages that are open to all.

(Q)uick Exit: Another way to exit BBS. This option hangs you up with out the message part. When using either exit option you have to hang up on your own. The BBS will not do it for you.

(M)ail status: This lets you know if the messages you left someone have been read or not.

(?)Help: I think this explains it self.

(X)pert mode: If xpert mode is on only the first letter of each word will be displayed. If (X)pert mode is off then the normal menu will be displayed.

(#)Read club: This is the private download section. The files here will be seen by club member's only.

Next month I will explain the department menu. Until then happy modeming !!!!!!!!!!!!!

@

ORKING WITH OS-9

By David Barnes

Welcome to a new series of articles dealing with OS-9 Level II. The title 'Forking with OS-9' came to be over a few cups of coffee and while using Multi-View. Multi-View is the new Tandy 'user friendly' point and click windowing environment for OS-9 Level II. If you have had the chance to experiment with Multi-View, you will know what we mean by 'forking'. Actually, forking is done in OS-9 without the use of Multi-View. Forking is sort of a subroutine that can be called. For example, the command DIR >/P& 'forks' the redirection of the output from the DIR command to the printer and runs it as a background task. Anyway, enough of this 'forking' talk. These articles will hopefully help you to understand OS-9 Level II and to find and fix some of the 'bugs' in the system. The following program listing is a great PD utility written by Kevin Darling. You will notice that it is an RS-DOS program, but when the program is typed in and run it will take a formatted 35 track SSDD diskette and format it to OS-9, and apply a file called SAVE9. SAVE9 is what OS-9 really needs and can only be found in the Development System. You should then copy the new SAVE9 command into your CMDS directory and set the ATTR bits. In the next series of articles, you will hopefully find some MODPATCHes for modules with bugs. There is no way to save a modpatched module under Level II. You must modpatch every time you want the fix installed. The SAVE9 command line uses the following syntax:

SAVE9 /d#/name module-name.

This way the next time you load the module, it will be repaired. Next month I will hopefully have some good modpatches for you to use your new SAVE9 command on. If you don't feel like typing in the program, it has been uploaded to the Mindmaster's BBS, (312) 463-8932, where it may be downloaded. Until then, keep on forking....

```

1 REM * DOWNLOADED FROM DELPHI I
NFORMATIONAL SERVICES
2 REM * RELEASED TO PD BY KEVIN
DARLING *
5 CLEAR3000
10 DIM A$(12)
15 FOR I=0 TO 11 STEP 2
20 READ S
21 PRINT"SECTOR "S" *****
*****"

```

```

25 FOR K=0 TO 1
30 A$(I+K)="
35 FOR J=1 TO 128
40 READ X
41 PRINTX;
45 A$(I+K)=A$(I+K)+CHR$(X)
50 NEXT J
55 NEXT K
60 DSKO$0,0,S,A$(I),A$(I+1)
65 NEXT I
99 DATA 1
100 DATA 0,2,118,18,0,79,0,1,0,0
,2,0,0,255,21,113,2,0,18,0,0,0,0
,0,0,0,88
101 DATA 1,16,23,2,112,100,115,9
7,118,229,0,0,0,0,0,0,0,0,0,0,0,0
,0,0,0,0
102 DATA 0,0,0,0,0,0,0,0,0,0,0,1
,0,3,32,1,0,35,1,0,0,18,0,18,3,8
,0,86,128
103 DATA 0,0,0,0,0,0,0,0,0,0,0,0
,103,45,0,0,0,0,0,0,0,0,0,0,0,0,0
,0,0,0,0
104 DATA 0,0,0,0,0,0,0,0,0,0,0,0
,0,0,0,0,0
200 DATA 0,0,0,0,0,0,0,0,0,0,0,0
,0,0,0,0,0,0,0,0,0,0,0,0,0,0,0,0
,0,0,0,0
201 DATA 0,0,0,0,0,0,0,0,0,0,0,0
,0,0,0,0,0,0,0,0,0,0,0,0,0,0,0,0
,0,0,0,0
202 DATA 0,0,0,0,0,0,0,0,0,0,0,0
,0,0,0,0,0,0,0,0,0,0,0,0,0,0,0,0
,0,0,0,0
203 DATA 0,0,0,0,0,0,0,0,0,0,0,0
,0,0,0,0,0,0,0,0,0,0,0,0,0,0,0,0
,0,0,0,0
299 DATA 2
300 DATA 255,240,0,0,0,0,0,0,0,0,0
,0,0,0,0,0,0,0,0,0,0,0,0,0,0,0,0
,0,0,0,0
301 DATA 0,0,0,0,0,0,0,0,0,0,0,0
,0,0,0,0,0,0,0,0,0,0,0,0,0,0,0,0
,0,0,0,0
302 DATA 0,0,0,0,0,0,0,0,0,0,0,0
,0,0,0,0,3,255,255,255,255,255,2
55,255,255
303 DATA 255,255,255,255,255,255
,255,255,255,255,255,255,255,255
,255,255
304 DATA 255,255,255,255,255,255
,255,255,255,255,255,255,255,255
,255,255
305 DATA 255,255,255,255,255,255
,255,255,255
400 DATA 255,255,255,255,255,255
,255,255,255,255,255,255,255,255
,255,255
401 DATA 255,255,255,255,255,255
,255,255,255,255,255,255,255,255

```

,255,255
402 DATA 255,255,255,255,255,255
,255,255,255,255,255,255,255,255
,255,255
403 DATA 255,255,255,255,255,255
,255,255,255,255,255,255,255,255
,255,255
404 DATA 255,255,255,255,255,255
,255,255,255,255,255,255,255,255
,255,255
405 DATA 255,255,255,255,255,255
,255,255,255,255,255,255,255,255
,255,255
406 DATA 255,255,255,255,255,255
,255,255,255,255,255,255,255,255
,255,255
407 DATA 255,255,255,255,255,255
,255,255,255,255,255,255,255,255
,255,255
499 DATA 3
500 DATA 191,0,0,88,1,16,23,18,2
,0,0,0,96,0,0,0,0,0,3,0,7,0,0,0,
0,0,0,0,0
501 DATA 0,0,0,0,0,0,0,0,0,0,0,0,
,0,0,0,0,0,0,0,0,0,0,0,0,0,0,0,
,0,0,0,0
502 DATA 0,0,0,0,0,0,0,0,0,0,0,0,
,0,0,0,0,0,0,0,0,0,0,0,0,0,0,0,
,0,0,0,0
503 DATA 0,0,0,0,0,0,0,0,0,0,0,0,
,0,0,0,0,0,0,0,0,0,0,0,0,0,0,0,
0,0,0,0
504 DATA 0,0,0
600 DATA 0,0,0,0,0,0,0,0,0,0,0,0,
,0,0,0,0,0,0,0,0,0,0,0,0,0,0,0,
,0,0,0,0
601 DATA 0,0,0,0,0,0,0,0,0,0,0,0,
,0,0,0,0,0,0,0,0,0,0,0,0,0,0,0,
,0,0,0,0
602 DATA 0,0,0,0,0,0,0,0,0,0,0,0,
,0,0,0,0,0,0,0,0,0,0,0,0,0,0,0,
,0,0,0,0
603 DATA 0,0,0,0,0,0,0,0,0,0,0,0,
,0,0,0,0,0,0,0,0,0,0,0,0,0,0,0,
,0,0,0,0
699 DATA 4
700 DATA 46,174,0,0,0,0,0,0,0,0,0,
0,0,0,0,0,0,0,0,0,0,0,0,0,0,0,0,
0,0,0,0,0
701 DATA 2,174,0,0,0,0,0,0,0,0,0,
,0,0,0,0,0,0,0,0,0,0,0,0,0,0,0,
,0,0,0,0
702 DATA 0,2,83,97,118,229,118,2
29,0,0,0,0,0,0,0,0,0,0,0,0,0,0,0,
,0,0,0,0
703 DATA 0,0,0,0,0,0,10,0,0,0,0,0,
0,0,0,0,0,0,0,0,0,0,0,0,0,0,0,0,
,0,0,0
704 DATA 0,0,0,0,0,0,0,0
800 DATA 0,0,0,0,0,0,0,0,0,0,0,0,

,0,0,0,0,0,0,0,0,0,0,0,0,0,0,0,0
,0,0,0,0
801 DATA 0,0,0,0,0,0,0,0,0,0,0,0,
,0,0,0,0,0,0,0,0,0,0,0,0,0,0,0,
,0,0,0,0
802 DATA 0,0,0,0,0,0,0,0,0,0,0,0,
,0,0,0,0,0,0,0,0,0,0,0,0,0,0,0,
,0,0,0,0
803 DATA 0,0,0,0,0,0,0,0,0,0,0,0,
,0,0,0,0,0,0,0,0,0,0,0,0,0,0,0,
,0,0,0,0
899 DATA 11
900 DATA 47,0,0,88,1,16,23,18,1,
0,0,0,123,88,1,16,0,0,11,0,1,0,0,
,0,0,0,0
901 DATA 0,0,0,0,0,0,0,0,0,0,0,0,
,0,0,0,0,0,0,0,0,0,0,0,0,0,0,0,
,0,0,0,0
902 DATA 0,0,0,0,0,0,0,0,0,0,0,0,
,0,0,0,0,0,0,0,0,0,0,0,0,0,0,0,
,0,0,0,0
903 DATA 0,0,0,0,0,0,0,0,0,0,0,0,
,0,0,0,0,0,0,0,0,0,0,0,0,0,0,0,
,0,0,0,0
904 DATA 0,0,0,0,0
1000 DATA 0,0,0,0,0,0,0,0,0,0,0,0,
0,0,0,0,0,0,0,0,0,0,0,0,0,0,0,0,
0,0,0,0,0
1001 DATA 0,0,0,0,0,0,0,0,0,0,0,0,
0,0,0,0,0,0,0,0,0,0,0,0,0,0,0,0,
0,0,0,0,0
1002 DATA 0,0,0,0,0,0,0,0,0,0,0,0,
0,0,0,0,0,0,0,0,0,0,0,0,0,0,0,0,
0,0,0,0,0
1003 DATA 0,0,0,0,0,0,0,0,0,0,0,0,
0,0,0,0,0,0,0,0,0,0,0,0,0,0,0,0,
0,0,0,0,0
1099 DATA 12
1100 DATA 135,205,0,123,0,13,17,
129,83,0,17,0,255,83,97,118,229,
134,2,198
1101 DATA 47,16,63,131,37,50,151
,0,166,128,129,13,39,41,129,44,3
9,246,129
1102 DATA 32,39,242,48,31,159,3,
79,16,63,0,37,40,52,80,31,49,16,
174,2,150
1103 DATA 0,16,63,138,37,10,53,8
0,16,63,2,37,3,32,209,95,16,63,6
,66,97,100
1104 DATA 32,76,105,110,107,32,9
7,116,58,32,52,5,48,141,255,237,
134,2,16
1105 DATA 142,0,13,16,63,138,158
,3,16,142,0,200,16,63,140,53,5,3
2,212,203
1106 DATA 85,129,229,229,229,229
,229
1200 DATA 229,229,229,229,229,22
9,229,229,229,229,229,229,22

9,229,229
1201 DATA 229,229,229,229,229,22
9,229,229,229,229,229,229,229,22
9,229,229
1202 DATA 229,229,229,229,229,22
9,229,229,229,229,229,229,229,22
9,229,229
1203 DATA 229,229,229,229,229,22
9,229,229,229,229,229,229,229,22
9,229,229
1204 DATA 229,229,229,229,229,22
9,229,229,229,229,229,229,229,22
9,229,229
1205 DATA 229,229,229,229,229,22
9,229,229,229,229,229,229,229,22
9,229,229
1206 DATA 229,229,229,229,229,22
9,229,229,229,229,229,229,229,22
9,229,229
1207 DATA 0,0,0,0,0,0,0,0,0,0,0,
0,0,0,0,0

FOR SALE
* 64K COCO 2 * HIGH PROFILE
KEYBOARD * MULTI-PAC INTERFACE *
RS DISK DRIVE 0 WITH FD 501
CONTROLLER * TRS80 CCR 81 * RS
SPEECH/SOUND CART. * DELUXE JOY-
STICKS * PROGRAMMABLE LIGHT
CONTROLLER * SPEECH SYSTEMS COCO
MIDI INTERFACE FOR 'LYRA' *
COCOMAX II * MAX EDIT *
.....PLUS.....
OVER 200 BITS (OR IS IT BYTES)
OF SPURIOUS SOFTWARE THE WHOLE
STICKY GOOEY BALL OF WAX FOR
ONLY \$400. CALL ME NOW.....I'M
WAITING....THE PHONE'S NOT RING-
ING YET....I'M DESPERATE.....
oh, (heh heh) here's the number.
HOME: 312-382-7955
WORK: 312-593-1100
ASK FOR ADAM OLSEN

*****SKYHAWK ENTERPRIZES*****
CUSTOM EPROM BURNING
SUBMIT YOUR BINARY FILE
READABLE BY TRS-80 COCO, TAPE OR
DISK. SPECIFY EPROM TYPE (2716,
2732, 2764, 27128, 27256, 68766)
CALL TONY PODRAZA AT
(312) 428-3576
-FOR CURRENT CHIP PRICES-
IF YOU HAVE YOUR OWN CHIP, WE
WILL ERASE, BURN, AND VERIFY FOR
ONLY.....\$5.00

Monthly meetings every **SECOND THURSDAY**

Information
for more
call: 462-0694

Glenside Public
Library
Fullerton Ave.
Glendale Hts, IL
7:30 to 9:30pm

Location

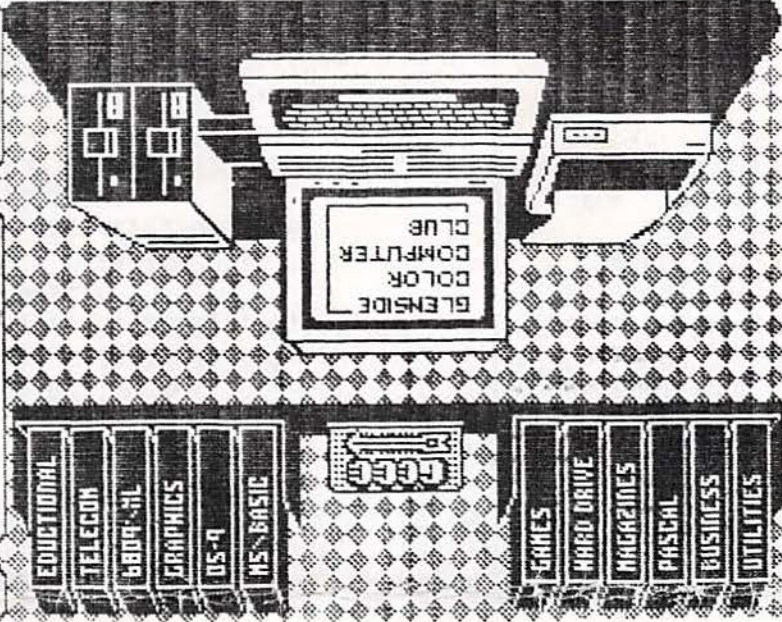

Glenside Color Computer Club



NO. SUBURBAN, IL 601
PM
9 FEB 1981



John (Tony) Podraza
119 Adobe Circle
Carpentersville IL 60110