

# CoCo~123



Glenside Color Computer Club, Inc.

Carpentersville, Illinois

Volume 36, Number 3

Autumn 2016

## CoCo ~ 123 Memory Map

### Routines

### Address

GCCC Officers .....	1
GCCC Information .....	2
GCCC Contributions .....	2
Contributors to this Issue .....	2
GCCC Meetings .....	2
From the President's Platen .....	2
Treasury Notes .....	3
Secretary's Notebook .....	3
Editor's Clipboard .....	3
ARTICLES .....	3
<b>The Hobbit Ported To 6809 Updated</b> .....	3
<b>TRS-80 Model 1</b> .....	4
<b>CoCoNIC</b> .....	5
<b>3D Printed ROM Cartridge</b> .....	5
<b>Dorsett Educational Tapes</b> .....	6
<b>One-Liner Programming Competition</b> .....	6
<b>Using a Receipt Printer with the CoCo/MC-10</b> .....	6
<b>Chicago TI International World Faire</b> .....	8
<b>What is a Battery?</b> .....	8
<b>SEGA Genesis Joypad Adapter for CoCo3</b> .....	9
<b>POP STAR PILOT</b> .....	12
<b>Vintage Computer Festival Midwest</b> .....	13
<b>Odds and Ends</b> .....	17
<b>Wikipedia Plea</b> .....	17
Calendar of Events .....	18
CoCoFEST! 2017 Information - The 5 "W's" .....	18

### Upcoming Events:

The 26<sup>th</sup> Annual "Last" Chicago CoCoFEST! **April 22-23, 2017**  
Regular meetings every 2nd Thursday @ Schaumburg Library

### G.C.C.C. OFFICERS

Here is the list of 2016 club officers and how to contact them.  
If you have questions about the association call one of the officers for the answers.

POSITION	NAME	PHONE	PRIMARY FUNCTION
President	Tony Podraza	847-428-3576	The buck stops here...
Vice-President	Chris Hawks	815-943-4690	Meeting planning, etc.
Treasurer	Geo Schneeweiss	815-832-4441	Dues and Purchasing
Secretary	Bob Swoger	630-589-4692	Records and Reporting
Director	Tony Podraza	847-428-3576	CoCoFEST! Organizer
Librarian	Brian Goers	708-805-1888	Software/Hrdwr Manager
Editor	John Mark Mobley	847-409-8604	Newsletter Production

Copyright ©2016 Glenside Color Computer Club, Inc.



Tony Podraza



Chris Hawks



Robert Swoger



George Schneeweiss



Brian Goers



John Mark Mobley

CoCo~123 - A Glenside Publication Since 1985

## CoCo~123 INFORMATION

CoCo~123 is the newsletter of the Glenside Color Computer Club. Your annual contribution of \$15.00 helps to keep our club going. Send your check to:

George L Schneeweiss, Glenside Treasurer  
13450 N 2700 E Road  
Forrest IL 61741-9629

Our treasury provides newsletters and good times with fellow CoCo users at our Annual "Last" Chicago CoCoFEST! and Annual Glenside Picnic.

## CoCo~123 CONTRIBUTIONS

If you have any suggestions for the newsletter or would like to submit an article, please contact the CoCo~123 Newsletter editor:

John Mark Mobley, Editor  
4104 Wren Lane  
Rolling Meadows IL 60008  
[johnmarkmelanie@gmail.com](mailto:johnmarkmelanie@gmail.com)

## CONTRIBUTORS TO THIS ISSUE

Jim Brain	Salvador Garcia
Chris Hawks	John Linville
Nickolas Marentes	Ian Mavric
John Mark Mobley	Tony Podraza
Kevin Savetz	George Schneeweiss
Lloyd Shotwell	Bob Swoger

## G. C. C. C. MEETINGS

The Glenside Color Computer Club meets the second Thursday of each month at the Schaumburg Township District Library at 7:00 pm. If you need a map, see our Glenside Homepage at:

<http://ncmedals.com/glenside/splmap.html>

A social get-together always follows the meeting at a nearby restaurant we lovingly call, "The Meeting After".

## FROM THE PRESIDENT'S PLATEN

It was a Thursday night in late 1984. There were about 40 people in the meeting room of the Glenside Library in Glendale Heights, IL. At the podium was a thin man with a big smile and dark hair talking to about three or four others. When the clock showed 7:00PM, we all found a chair and the fledgling Glenside Color Computer Club meeting started. It was during these meetings that I first met the big, friendly SysOp of the DECB-based BBS that was the official telecom arm of the club. He and I became staunch friends over the years, traveling to New Jersey for the 1988 Rainbow Fest with Ed Hathaway, learning about Ed's stint as one of the "Three Guys in Blue Jeans" band, and having just a raucous time on the road as well as at the Fest. The big man inspired me to start up the OS9 based operating system and power up my own BBS,

Glenside's "Cup of CoCo" in 1990. He was a musician extraordinaire, though I did not find that out until a few years later. He became good friends with my second son, and was like a big brother to him.

He never lacked for a good joke. His knowledge of OS9 enabled him to perform a feat that left his co-workers in awe when the power went out at one of his places of employment. The firm's computers were UNIX-based and usually took 4 to 6 hours to get everything back online on a cold boot. As UNIX and OS9 are similar, he had the firm up and running in an hour.... no glitches or errors, either.

He has been a past president of Glenside, a past newsletter editor and formatter, and just an all-around fantastic husband, dad, and personal friend. He introduced me to infant hip dysplasia and the way to correct it and to the world of Autism, and the need for more research and understanding of the condition. It was into these worlds that his own children were born, both of whom I love and am privileged to be considered "Uncle Tony" by them.

Over the past two and a half years, he and his family, have been fighting an aggressive form of brain cancer, something that was supposed to have terminated him after 6 months. After the first round of treatments, a second type of treatment was suggested...then a third type.... all seemed to extend his presence, but they did not eliminate the killer.

On October 23, 2016, he passed. Many people stood in line to say, "goodbye". It was one of the hardest things I have ever had to do.

I have heard it said that the measure of a life is a dash between two dates. His was a brilliant one.

David Barnes

1958



2016

Tony Podraza, President  
Glenside Color Computer Club

## TREA\$URY NOTES

As of December 8, 2016 we have \$5978.59 in checking. We have 78 paid members this year. We presently have 17 members lost due to email address changes.

George Schneeweiss, Trea\$urer  
Glenside Color Computer Club

## THE SECRETARY'S NOTEBOOK

We have been successful in obtaining a meeting room at the Schaumburg Township District Library for the second month in a row. Because our numbers have fallen we were no longer eligible for a larger room that we were able to book 3 months in advance. Our present situation is that we must book exactly 2 weeks in advance and we no longer require a library card. We do thank those that came forward to offer theirs when we thought we had the need.

Greatly missed is our vice president Chris Hawks due to Nancy's need for his presence at home to care for her as she recovers from operations required after a fall earlier this year.

**Chris Hawks** writes: Nancy is doing pretty well. Physical Therapy is three times a week. She can walk a few minutes, a couple of times a day with a walker. And she'll start on stairs pretty soon. She's able to move the hip and knee a little more each day with all the exercises. She can get out for church and shopping and stuff, but it's a long process. Keep the prayers and good thoughts coming. Happy Thanksgiving!!

Bob Swoger, Secretary  
Glenside Color Computer Club

## THE EDITOR'S CLIPBOARD

The club holds a business meeting around the second Thursday of the month. You can submit agenda ideas to Bob Swoger, you can attend the meeting in person, or you can join the meeting by way of Google Hangouts.

The club is trying to release 4 newsletters a year. We try to send the newsletter on or before the first day of spring, summer, fall/autumn, and winter. If you have an article or an article idea please let me know.

The club holds a yearly festival called the Chicago CoCoFEST! This is the best way to get to know the Tandy Color Computer community.

Besides all this, the Tandy Color Computer community has a mailing list called the CoCoList, Freenode IRC (Internet Relay Chat) CoCo\_Chat, a Facebook page, The CoCo Crew Podcast, The TRS-80 Trash Talkers Podcast, and The Tandy Assembly Vintage Computer Festival. And there is more besides all that.

So welcome to the Tandy Color Computer community. There is much to see, and many people to meet.

John Mark Mobley, Editor  
Glenside Color Computer Club

## The Hobbit Ported to MC6809 Updated

by John Mark Mobley and Bob Swoger

In our last newsletter we ran an article by Pere Serrat announcing the release of his final version of The Hobbit for the CoCo 3. After checking it out using Vcc and **LogiCall** we discovered it to be fragile – it wouldn't load. The problem was that unless the CoCo was reset after running another program, Hobbit wouldn't load.

The answer to the problem was to add a BASIC loader for the Hobbit on its program disk.

```
10 WIDTH32:CMP
20 CLEAR 100,32668
30 RUNM "H2X"
9999 SAVE "HOBBIT"
```

Now you will see this with these colors:

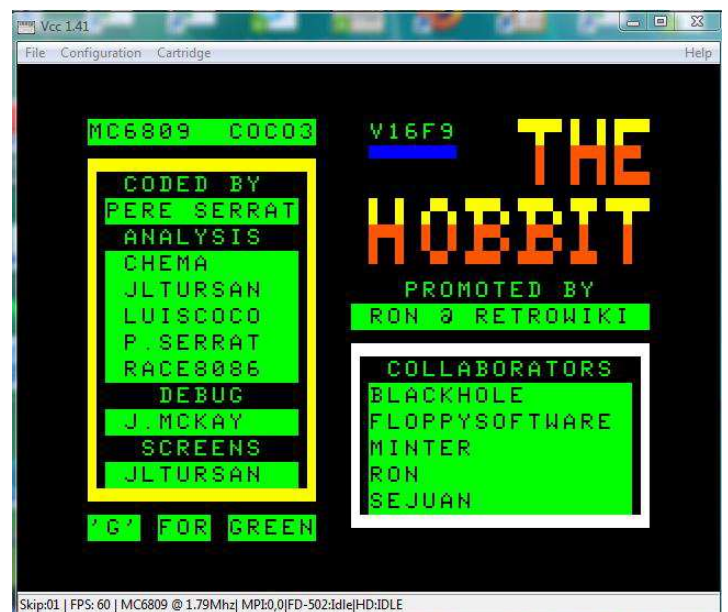
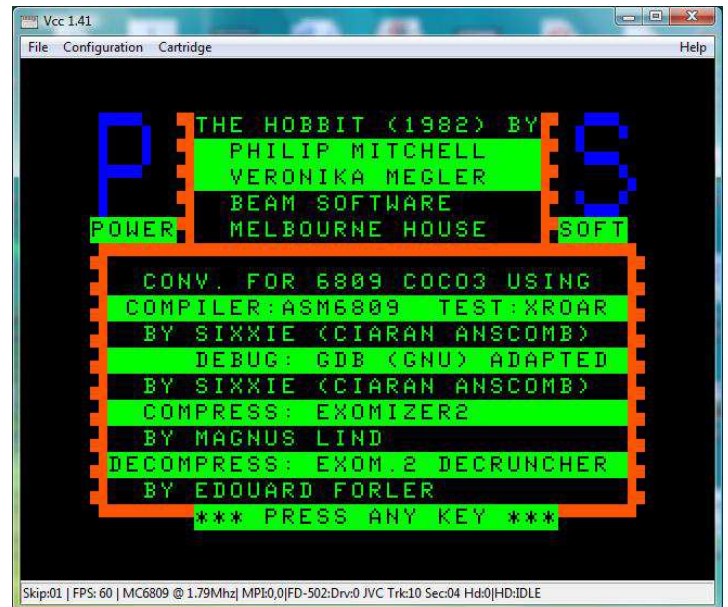



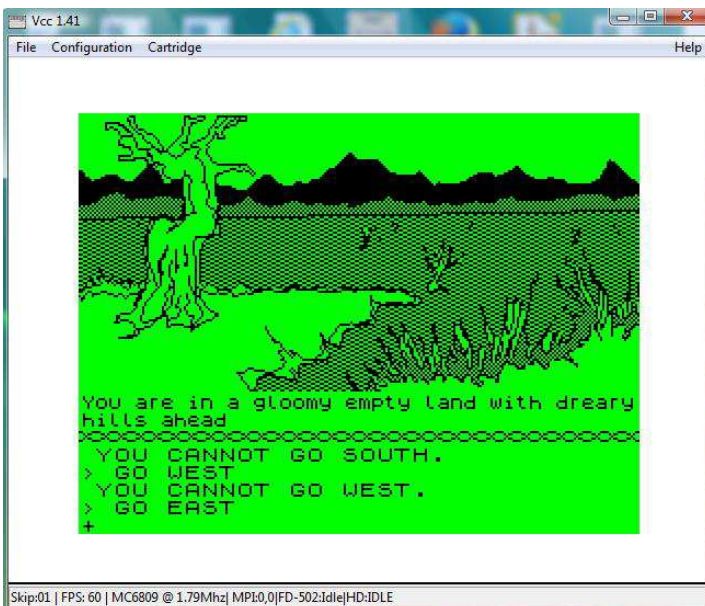

To make the program disk friendlier to **LogiCall**, save the BASIC loader, HOBBIT.BAS, to become the first file on the disk, which will give the disk the name HOBBIT instead of H2X. Now all you will have to do is select HOBBIT.BAS using **LogiCall** and the game will run perfectly.

The quickest way to acquire this fix is to simply update **LogiCall** by downloading LogiCoCo.zip and running LINSTALL.BAT

Since the game was ported from the Sinclair the original programmer never had a RAM problem as the Sinclair gives the programmer all the RAM from 26710 to 65535. Too bad TRS couldn't do the same thing. Pere would not have had to do all the memory manipulation.

## TRS-80 Model 1

by John Mark Mobley

2017 is the 40<sup>th</sup> anniversary of the TRS-80 Model 1. This computer used the Zilog Z80 microprocessor. The TRS-80 computer owners have been invited to the 26<sup>th</sup> Annual "Last" Chicago CoCoFEST! There has never before been a fest for the Tandy / TRS-80 monochrome computers.

**The Tandy / TRS-80 monochrome computers include:**

- TRS-80 Model I
- TRS-80 Model II
- TRS-80 Model III
- TRS-80 Model 4
- TRS-80 Model 12
- TRS-80 Model 16
- TRS-80 Model 16B
- TRS-80 Model 100
- TRS-80 Pocket Computer 1 (PC-1)
- TRS-80 Pocket Computer 2 (PC-2)
- Tandy / TRS-80 Pocket Computer 3 (PC-3)
- TRS-80 Pocket Computer 4 (PC-4)
- Tandy Pocket Computer 5 (PC-5)
- Tandy Pocket Computer 6 (PC-6)
- Tandy Pocket Computer 7 (PC-7)
- Tandy Pocket Computer 8 (PC-8)
- Tandy 10
- Tandy 102
- Tandy 200
- Tandy 6000
- Tandy 6000 HD
- And clones

**The color computers with Motorola microprocessors include:**

- Tandy Data Products TDP-100
- TRS-80 MC-10
- TRS-80 Color Computer
- TRS-80 Color Computer 2
- Tandy Color Computer 2
- Tandy Color Computer 3

### **The Color Computer clones include:**

Dragon 32  
Dragon 64  
Tano Dragon  
Matra Alice  
Prologica CP400 Color II  
CP400 Color II  
Varixx VC50  
LZ Color64  
Dynacom MX1600  
Codimex CD6809  
Micro-SEP  
Sampo Color Computer  
Sysdata Tclor

### **Color Computer hopeful successors included:**

Tomcat TC-9  
TC-70  
MM/1  
AT306  
PTK68K-4

### **New additions include:**

CoCo3FPGA  
CoCoPi

Technically the Tandy 1000 and Tandy 2000 could do color, but now we are getting into IBM PC clone computers with Intel microprocessors.

The current thought is that the Tandy / TRS-80 non-CoCo Special Interest Group (SIG) will continue to meet at the CoCoFEST! until they grow large enough to hold a separate festival. We need to welcome them at our festival so that they will one day welcome us at their festival. This may be an opportunity for our club's membership to grow.

There is some concern that encouraging people to bring non-CoCo computers to the CoCoFEST! will change the atmosphere of our festival. The booth arrangements will separate the SIG from the CoCo group. The SIG might cause more scheduled seminars than our time can handle. We may need an extra meeting room to handle some extra seminars. We should try to limit the time of seminars to about 25 minutes. The TRS-80 SIG could meet in the lunchroom. We are primarily optimistic that this will work out well for both groups. We may outgrow our current venue. That could be a nice problem to have.

Both groups might be inspired by the achievements of the other. Note the good points of each setup and how each evolved over time since the original purchase. Try to look past any prejudice you might have about your own machine. If someone "talks down" your computer, try to remember what Proverbs says; "A gentle answer turns away wrath, but a harsh word stirs up anger." (New International Version) I found two videos that talk on this subject. The first one says to play it cool. The second one is a bar room fight that started when a

Klingon insulted Montgomery Scott's ship. This is taken from "The Trouble with Tribbles" episode of Star Trek.

Wisdom Video

<https://www.youtube.com/watch?v=0OFkicx3AfU>

Video: Don't let this be the CoCoFEST!:

<https://www.youtube.com/watch?v=tMrzdKzQTf8>

### **CoCoNIC**

by Jim Brain of RETRO Innovations

---

Introducing a Network Interface Controller (NIC) for the CoCo.

Photo:

<https://postimg.org/image/c9ilpetml/>

More photos:

<https://www.facebook.com/go4retro/photos>

### **3D Printed ROM Cartridge**

by John Mark Mobley

---

There were two ROM Cartridges on display at the 2016 CoCoFEST! Boisy Pitre has one that was based on a traditional plastic injection-molding machine. And John Strong had one that was produced using a 3D printer.

There are cases being made for the new Multi-Pak Interface. There are cases for the CoCoSDC. There are cases for new devices for the MC-10. Zippster has designed a game cartridge for the MC-10, and John Strong's MCX cases work for that.

I was amazed, and wondered how long before we can make a new case for the CoCo. A 3D printer capable of printing a new case for the CoCo would likely be large and expensive, but it is not necessary to own such a machine in order to reap the benefits. It is possible to send the design files to a business that specializes in producing larger designs. So perhaps I should ask how long will it be before it is cost effective to produce new cases for the CoCo.



John Strong made a two tone (red and black) printed cartridge.





### Dorsett Educational Tapes

by Kevin Savetz and John Mark Mobley

Kevin Savetz approached me about helping him to test some rare cassette tapes for the CoCo:

**Kevin wrote:** John Mark, I have digitized several rare cassette tapes for the CoCo from Dorsett Educational Systems. Need help from the CoCo community to test them/get them working. Atari folks have gotten the Atari version of these working.

Link:

<https://archive.org/details/TRS-80ColorComputerDorsettEducational>

Maybe you can put the word out in your newsletter/social media.

Kevin Savetz

Email: [antic@ataripodcast.com](mailto:antic@ataripodcast.com)

Web Page: <http://ataripodcast.libsyn.com/>

I have reviewed one of the Dorsett Educational tapes on Thomas Edison. I can hear data, then audio, followed by more data and audio. It should be a mono (not stereo) file. The data and the voice/audio are on the same track. Apparently no special hardware was required to read this file when it was new. The program can use motor on/off and audio on/off to prevent the data portion from playing out the speaker.

I used the XRoar emulator to listen to this file. The XRoar emulator can load a digital audio file, such as a wave file. XRoar can also emulate the audio portion playing through the speaker.

The audio file I listened to has too much noise and/or too little signal strength.

The file uses Frequency-Shift Keying (FSK) for modulation of the data. Each bit of data is recorded as one cycle of a sine wave. The frequency of the sine wave is either 1200 Hz or 2400 Hz. The CoCo hardware can measure if the signal is less than zero or greater than zero to demodulate the audio stream. Because the frequency of interest is so narrow (1188-1212 Hz and 2376-2424 Hz) it should be fairly/relatively easy to filter out the noise. The frequency ranges are a guess that is based on +/-1% accuracy.

The data needs to be filtered and re-digitized/re-modulated. I think one way to do this is with a non-real-time software filter. Once that is done I think the data can be recovered. One of the tapes should have the program needed to drive the system.

The system is trying to emulate an educational filmstrip projector with audio – the kind where you would play an audio cassette and you would be prompted when to advance to the next slide. The system can generate an image on the screen and play some audio of an announcer teaching on a subject. Then a question can be asked and the system can pause and wait for the user to answer the question.

This is the kind of thing that needs to be preserved for future generations. Kevin would like to preserve these tapes on archive.org. If you would like to help with this project, contact John Mark Mobley at [johnmarkmelanie@gmail.com](mailto:johnmarkmelanie@gmail.com) or Kevin Savetz at [antic@ataripodcast.com](mailto:antic@ataripodcast.com).

### One-Liner Programming Competition

by Ian Mavric

Dusty from the TRS8Bit newsletter (basically a newsletter for the Model I/III/4 but these days about any Tandy computer people care to write about, including the CoCo) has a one-liner programming competition. It would be good to see a few entries from CoCo owners. And there are so few competitions these days relevant to vintage micros.

Info is on his web page:

[http://trs-80.org.uk/Tandy\\_Page\\_1x.html](http://trs-80.org.uk/Tandy_Page_1x.html)

<http://www.fabsitesuk.com/tandy/trs8bit1004.pdf>

Cheers, Ian.

### Using a Receipt Printer with the CoCo/MC-10

By John Linville

I wrote up a little discussion of using a CoCo or MC-10 to drive a modern-ish thermal receipt printer equipped with an RS-232 interface using Color BASIC. The discussion involves not only the basic serial cabling, but also use of a RAM hook to make Color BASIC add the proper line endings to keep the printer happy. Assembly and Color BASIC sources are shown as well.

In Episode 9 of The CoCo Crew Podcast, Neil and I discussed the role of printers in the retro computer hobby. For some reason this became one of our most popular segments! We continue to get comments and requests for information about printers and how to make use of them with the CoCo and MC-10.



Alphacom 32 Thermal Printer

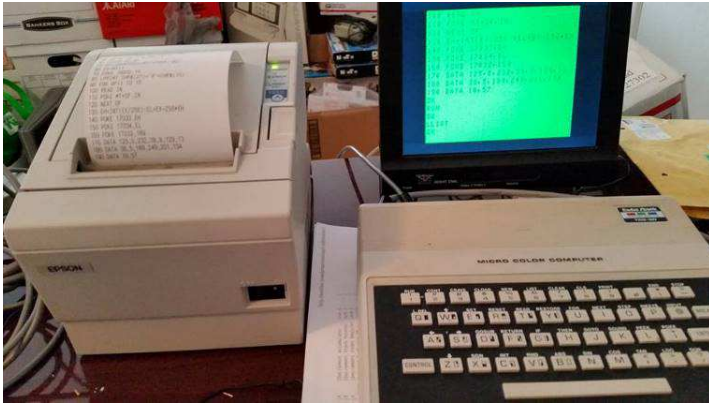

MC-10 driving a receipt printer

### Upon Receipt

Around that same time, I developed an interest in receipt printers. These thermal printers are a popular target for various microcontroller and "Maker"-style hacking projects, partly because they are readily available through eBay and other surplus vendors. The continued use of such devices in retail also ensures a ready supply of paper to feed them. The fact that many such printers feature an RS-232 serial interface is just icing on the cake! The Epson TM-T88III M129C is just such a device...but not all of them have RS-232 serial ports!

Having acquired a receipt printer with a serial port, I set about to connecting it to my MC-10. This is somewhat trickier than it sounds, since the MC-10 (and the CoCo) redefine the usage of the pins on the serial port depending on whether one is talking to a printer or to a modem, as explained here. With the proper cable in place, there is still the matter of setting the communications parameters, particularly the baud rate. The settings for the printer are handled by setting DIP switches internal to the device, while setting the baud rate used by the internal ROM routines on the CoCo and MC-10 involved setting a value in memory (i.e. "POKE 16932,10" for 4800 baud on the MC-10, or "POKE 150,7" for the same speed on the CoCo).

With the correct cabling and speed settings, printing almost works! Unfortunately, the printer and the CoCo/MC-10 don't agree on what constitutes the end of a line of output. This not only causes delays when printing small amounts of text, it also causes the output itself to be formatted incorrectly.

### Hook Me Up

In the distant (?) past, there was some disagreement about how to indicate the start of a new line of text (a.k.a. "newline") in an ASCII-encoded file. In the days of the Teletype, "carriage return" (CR) represented physical movement of the print mechanism to the left edge of the paper, while "line feed" (LF) represented moving the paper vertically down to the next line of text. These two functions generally go together, making some folks feel that having two characters to represent

one action was redundant. Therefore, some systems used just the CR, some used just the LF, and others continued to use both. The CoCo and MC-10 are in the "CR-only" category, while the receipt printer requires both CR and LF to process a newline.

What needs to happen is to change Color BASIC to output an LF immediately after any CR is sent to the printer. But Color BASIC is in the ROM! How is this possible? Well, it turns out that the writers of Color BASIC were smart enough to identify several places in the ROM where it seemed potentially useful to let other software take control and modify Color BASIC's behavior. These are called RAM hooks, and there are a number of them. One such hook gets called whenever a byte is output by Color BASIC. We just need a little assembly language program to insert an LF after a CR is sent to the printer, and a way to hook it into Color BASIC.

The CoCo assembly language program looks like this:

```
DEVNUM equ $006f

    pshs b      save B reg
    ldb DEVNUM load device number
    incb        increment for testing purposes
    puls b      restore B reg
    beq exit    if device number == -1, then exit
    bpl exit    if device number >= 0, then exit

    cmpa #$0d  is output a CR?
    bne exit    if not, then exit
    jsr $a2bf  send CR to line printer
    lda #$0a   change original CR output to LF

exit  rts      return from RAM hook
```

While the MC-10 version looks like this:

```
DEVNUM equ $00e8

    tst DEVNUM test device number (only 0 or -2)
    beq exit    if device number == 0, then exit

    cmpa #$0d  is output a CR?
    bne exit    if not, then exit
    jsr $f9c9  send CR to line printer
    ldaa #$0a  change original CR output to LF

exit  rts      return from RAM hook
```

The assembly language program itself is fairly trivial. It checks the output device number for a value of "-2" (which represents the printer). If the device number is "-2" then it checks for a CR. For an output value other than CR or for any output device value other than "-2" it simply returns having done nothing. For a value of "-2", the program proceeds to output the CR to the printer, then modifies the output value to LF and allows the program to proceed to output an LF as well.

### BASICly Done

The BASIC program that installs the assembly code is a bit more complicated. It starts by determining the highest address in use by the BASIC interpreter. It then uses the CLEAR command to adjust that address downward just enough to leave space for the assembly language program described above. The CLEAR command wipes out any existing variables, so the program then proceeds to again determine the highest address used by BASIC and saves that information for

later. At this point, the BASIC program takes the opportunity to set the printer port baud rate as required by the printer, and to send a reset command sequence to the printer.

At this point the program POKes the assembly code into memory just above BASIC. Then it pokes the address of the start of the assembly program into the 2nd and 3rd bytes of the character output RAM hook. Finally, the value for a JMP instruction is POKed into the 1st byte of the character output RAM hook, activating the character output hook program. Now the printer will work with Color BASIC!

Here is the CoCo version of the BASIC code as described above:

```
10 MT=256*PEEK(35)+PEEK(36)
20 SB=256*PEEK(33)+PEEK(34)
30 SS=MT-SB : NT=MT-21+1
40 CLEAR SS,NT
50 MT=256*PEEK(35)+PEEK(36)
60 EX=MT+1
70 POKE 150,7
80 PRINT # -2,CHR$(27)+"@"
90 PRINT # -2,CHR$(10)
100 FOR OF=1 TO 21
110 READ IN
120 POKE MT+OF,IN
130 NEXT OF
140 EH=INT(EX/256):EL=EX-256*EH
150 POKE 360,EH
160 POKE 361,EL
170 POKE 359,126
180 DATA 52,4,214,111,92,53,4,39
190 DATA 11,42,9,129,13,38,5,189
200 DATA 162,191,134,10,57
```

And, here is the MC-10 version:

```
10 MT=256*PEEK(161)+PEEK(162)
20 SB=256*PEEK(155)+PEEK(156)
30 SS=MT-SB : NT=MT-15+1
40 CLEAR SS,NT
50 MT=256*PEEK(161)+PEEK(162)
60 EX=MT+1
70 POKE 16932,10
80 LPRINT CHR$(27)+"@"+CHR$(10)
90 FOR OF=1 TO 15
100 READ IN
110 POKE MT+OF,IN
120 NEXT OF
130 EH=INT(EX/256):EL=EX-256*EH
140 POKE 17033,EH
150 POKE 17034,EL
160 POKE 17032,189
170 DATA 125,0,232,39,9,129,13
180 DATA 38,5,189,249,201,134
190 DATA 10,57
```

Those little programs may not look like much, but they sure are handy for giving the CoCo or MC-10 a modernish printer that can be fed with off-the-shelf paper. Plus, they allow for lots of interesting printer output to be driven by Color BASIC rather than having to do it all with assembly language. Not bad for some eBay shopping and a little bit of BASIC code!

This little project has been fun, and I think it could lead to more. These little printers have some cool capabilities, including various graphics capabilities and some point-of-sale features. Maybe we can explore those in the future? If you want to see what comes next then I hope that you will continue to stay tuned!

### **Chicago TI International World Faire** by John Mark Mobley

---

The Chicago TI International World Faire is a vintage computer festival for the TI-99/4A. I attended the festival, which was held October 15, 2016 in Evanston, IL. The attendance was about 35 people. I was welcomed even though I let it be known that I was more fond of the CoCo. I passed out business cards that promoted the CoCoFEST! and they did not throw me out.

I learned fbForth (File-Based Forth) from Lee Stewart. Lee gave a presentation on the low-level details of Forth. Lee has created a cartridge for the TI-99/4A that has many words/subroutines in its dictionary. I gather that his code is complete with comments, and that much of his work could be ported to the CoCo, because Forth is somewhat portable. A logical next step in development would be for someone to develop a game that runs in Forth. Lee says that Forth running directly on the computer (not running as another application in an operating system) has better performance for real-time applications like action games. So Forth on a vintage computer is better than running gForth (GNU Forth) in Linux, as far as deterministic behavior is concerned.

Someone at the Faire had taken it on himself to gather almost every bit of documentation on the TI-99/4A and place it in an organized and text-searchable collection. I wish we had this for the CoCo.

### **What is a Battery?** by John Mark Mobley

---

Calling something a battery is a way of making something plural. If you have a battery of something then you have two or more items. You can have a 9 volt dry cell battery because it is generally made of 6 cells in series. Each zinc-carbon or alkaline (Zn/MnO<sub>2</sub>) cell can deliver 1.5 volts, so 1.5 volts \* 6 = 9 volts.

Galvanic cell, voltaic cell, or electro-chemical cell, are just different names for the same thing. I think I remember talking to someone from another country referring to an electro-chemical cell as a capacitor or



condenser. From the conversation I was able to pick up on what he was referring to. An electro-chemical cell is made by placing two dissimilar metals in an electrolyte.

An electric battery may also be referred to as a voltaic pile, or accumulator.

There are two classifications of cells, primary cells and secondary cells. A primary cell is not rechargeable. A secondary cell is rechargeable.

I would define an electric battery as consisting of two or more cells. However, it is becoming increasingly popular to refer to it as consisting of one or more cells. You may have to consider your audience and then choose your words. If you go to Walgreen's website and search for "AA cell" vs. "AA battery" you will likely get different results.

An alkaline AA cell starts out at 1.6 volts and runs down to 0.9 volts and is then considered dead. A nickel metal hydride (NiMH) cell starts out at 1.2 volts and runs down to 1.0 volts and is then considered dead. So the discharge curve on a NiMH cell is flatter than an alkaline cell.

Electro-chemical cells have a self-discharge characteristic. Normal NiMH cells can self-discharge in about 41 days. However, low self-discharge NiMH cells are now available. The self-discharge rate is somewhat dependent on temperature.

I recommend primary lithium cells/batteries over alkaline cells/batteries for freezing/very cold temperatures. Also a lithium 9 volt battery has more amp hours (Ah) and a longer shelf life than an alkaline 9 volt battery.

There is a primary AA lithium-iron cell called the AA Energizer Ultimate Lithium. A lithium-iron cell runs at about 1.5 volts. It has more Ah (amp-hours), a flatter discharge curve, lower operating temperature, and a longer shelf life than an alkaline cell. However, it is also more expensive, and you cannot ship lithium cells/batteries via the United States Post Office.

So the next time you sense that your smart phone is about to run out of power, you may want to say: "My galvanic cell on my smart phone is dying and I am going to need to go for now."

Where do we use batteries?

Flashlights, electric clocks, gas alarms (smoke detectors and carbon monoxide (CO) detectors), wall thermostats, computer laptops, clocks and BIOS backup, portable radios and TVs, UPS, watches, pod games, remotes, cameras, flash units, autos, telephones, two-way radios, microphones... (What did I forget?) Photocells. There is a lesser-known battery/condenser that charges itself while sitting on the shelf called an electret. They make today's condenser microphones possible.

Link:

[https://en.wikipedia.org/wiki/Electret\\_microphone](https://en.wikipedia.org/wiki/Electret_microphone)

Remember Polo Pac batteries? I made a low count transistor TRF AM receiver for a friend once. It looked to the user that it had no power source.

I noted a joke by George Carlen asking the audience, "If we have A batteries, why not B or C batteries?" That showed his ignorance. The first tube radios used an A battery to power the filaments, a B battery to power the plate and screen and sometimes a C battery to bias the control grid. Then along came the transistor and that kind of unit ran entirely on the filament battery.



### SEGA Genesis Joypad Adapter for CoCo3

by John Linville

---

The following is taken for a web log (blog)...

Blog: <http://tinyurl.com/j4xempn>

Important points:

- works with all CoCo's for direction and single button
- supports Atari, SEGA SMS, SEGA Genesis, and compatible joysticks/joypads
- serial port connection is NOT required for normal use
- serial port connection will be required for games to use 3 buttons and/or Start

In earlier posts on this blog, I have covered a couple of options for building a digital joystick to work with the Tandy Color Computer (i.e. CoCo) or for hacking an existing controller for the same purpose. One complaint I receive is that people want to use their existing (either purchased or home-built) digital controllers without having to modify them for use with a CoCo. Fear not -- there is a solution! Just read on...

Design Basics

This joypad adapter design is fundamentally based upon the design described in "Atari Joystick Adapter" on page 135 of the February 1984 edition of Color Computer Magazine. The direction signals are identical between the "standard" 80's-era Atari joystick and the

later SEGA joypads, so an identical circuit handles both types of controllers with regard to direction control.

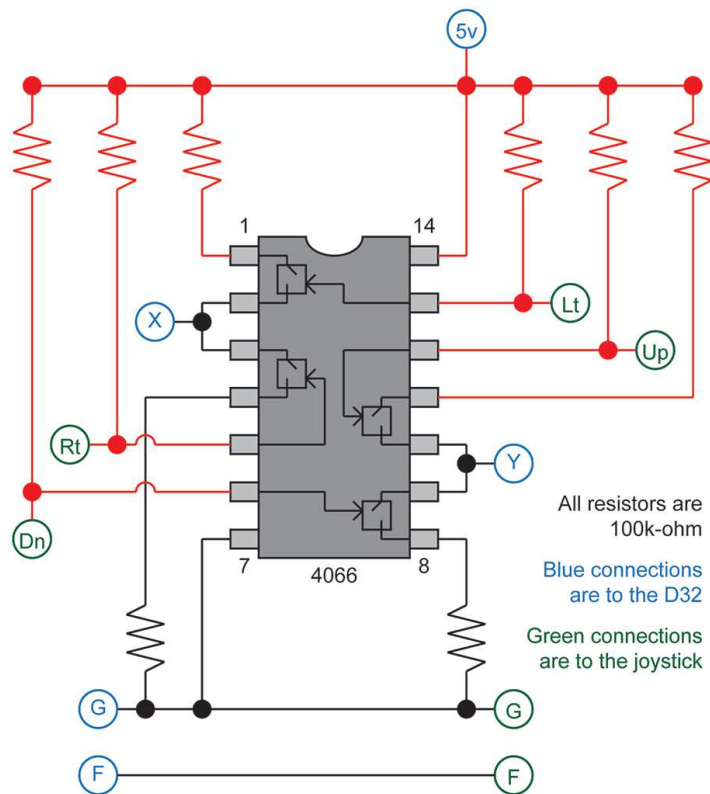

Schematic blatantly "borrowed" from [vrai.net](http://vrai.net) -- thanks!

The schematic above shows a single button (labelled as "F") with a "straight-through" connection. That works fine for the single button on an Atari joystick. When using a CoCo3, a 2nd "straight-through" connection will handle use of the 2nd button on a SEGA Master System controller as well. Unfortunately, SEGA Genesis (aka Mega Drive) controllers complicate matters...

### Genesis Buttons

The hardware used to multiplex the buttons on the Genesis joypad does not merely pull down the button signal. Instead it drives the signal either low or high depending on the state of the button presses. This works fine for the Genesis where presumably the button lines are not shared for any other purpose. But on the CoCo, those lines are also used when scanning the keyboard. Using a "straight-through" connection to a Genesis controller will cause some keys on the keyboard to appear "dead" (i.e. unresponsive). Adding reverse-biased diodes in-line with each button signal will prevent the Genesis controller from driving the lines high, thereby avoiding any interference with the keyboard scan on the CoCo. The circuit continues to work fine with Atari joysticks and SEGA Master System controllers as well, of course.

### More Is Better

The CoCo3 only supports two buttons on its joystick inputs, so we could stop here. But a little research reveals that the Genesis controller only uses two lines for button inputs, and a third line to drive a multiplexer that switches between B/C and A/Start. If the CoCo3 could drive that multiplexer, then the CoCo3 could also read those extra buttons!

The only easily accessible digital output on the back of the CoCo is the "Transmit" line on the RS-232 serial port. That signal is not electrically compatible with the input to the Genesis controller's multiplexer, but a simple circuit using an NPN transistor and a couple of resistors can condition the CoCo's RS-232 "Transmit" line suitably for the multiplexer. Now the CoCo3 can select the active button pair with the equivalent of a "POKE 65312,0" or "POKE 65312,2". This allows the CoCo3 to read all four buttons on the Genesis controller.

If you are interested in more technical details, please refer to the schematic online.

Schematic: <http://tinyurl.com/go3o8p7>

Video: <https://youtu.be/tc8-KmxaOXM>

A dual-joypad version of this adapter was produced and built by my podcasting partner Neil Blanchard. He had it available for sale at CoCoFEST!, and he continues to take orders for them by email. This device uses the design described above and will support use of all of the buttons on the standard "3-button" SEGA Genesis joypad on the CoCo3. I believe these items have sold well, so now there is a "critical mass" of these items out in the community waiting to be used effectively. Hopefully we all can think of ways to make use of 3 action buttons (plus Start) in a CoCo3 game -- what will you write? What will I write? Well, stay tuned...



John Linville

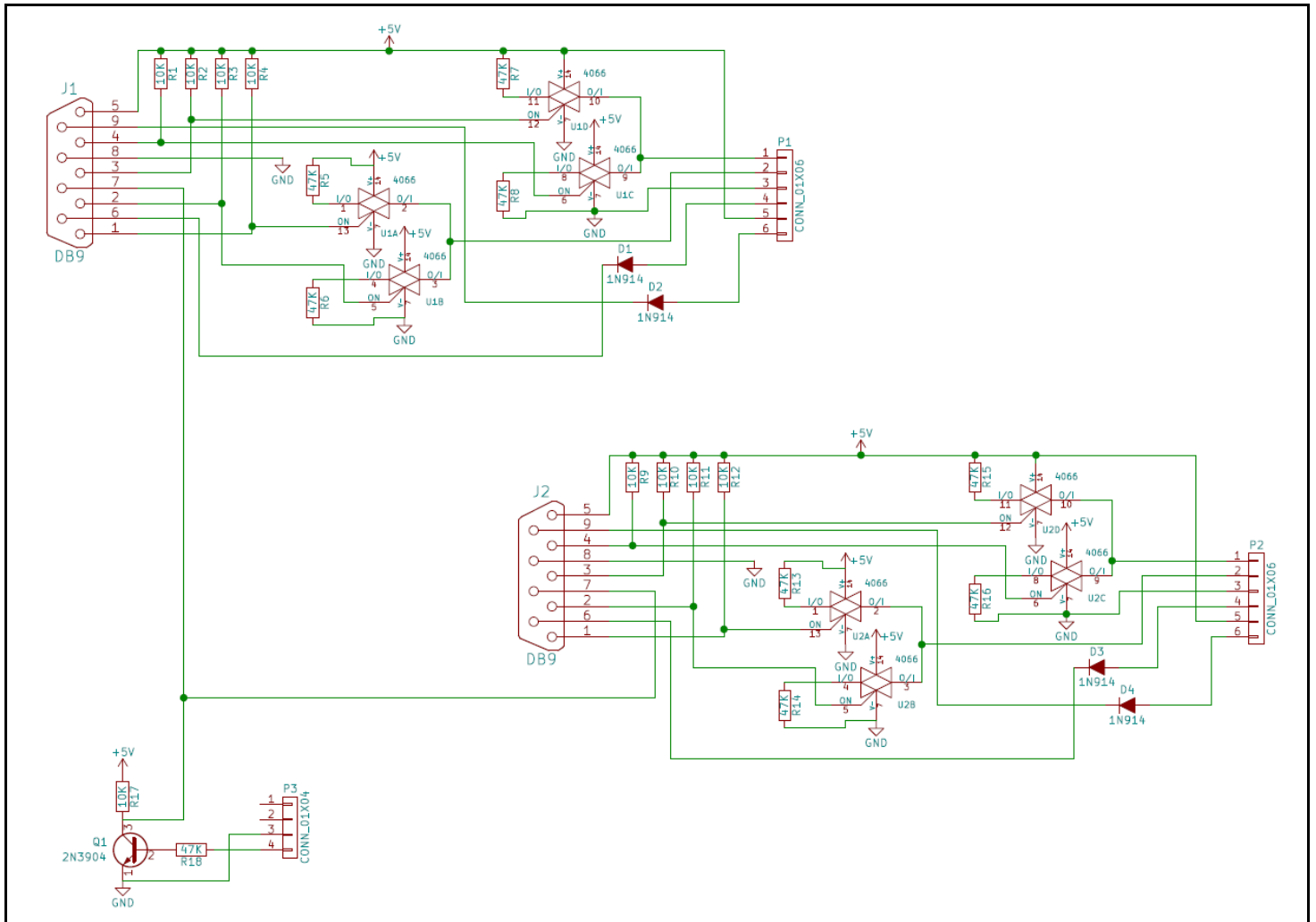

SEGA Genesis Joypad Adapter Schematic: <http://tinyurl.com/go3o8p7>

By John W. Linville

Date: January, 12, 2016

J1 and J2 go to the SEGA Genesis joypad connectors

P1 and P2 go to the CoCo's joystick inputs

P3 goes to the CoCo's serial port

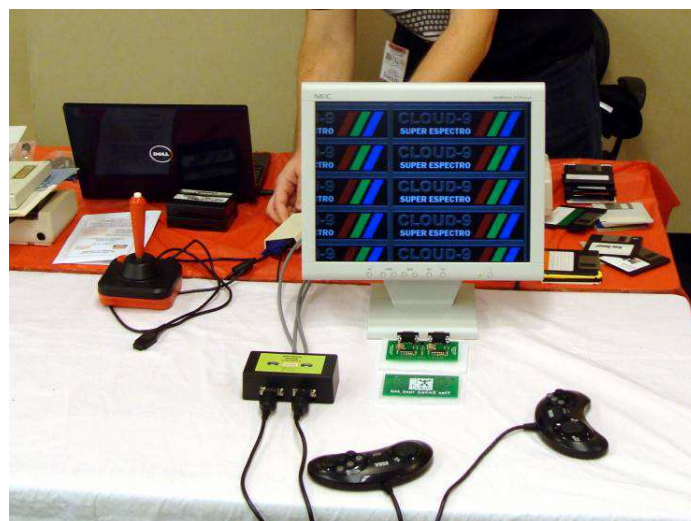

Neal Blanchard was selling these joystick adapters at the 2016 CoCoFEST!



# POP STAR PILOT

by Nickolas Marentes



Can you fly through  
five zones of aerial  
obstacle course?

Over 80 screens of high detail  
smooth scrolling arcade action!

High flying excitement for your  
Tandy Color Computer 3

512K Memory Required

<http://www.members.optusnet.com.au/nickma/PopstarPilot/31.html>

## Vintage Computer Festival Midwest (VCFMW)

by John Mark Mobley

The VCFMW was held in Elk Grove Village, IL on Sept. 10-11, 2016.

It was wonderful because of the people I met.

I met Bill Herd, designer for the Commodore 128 project. Bill was very willing to talk to me about Commodore hardware. Meeting Bill was the highlight of the show. Bill gave a presentation on "Tales from Inside Commodore". Dr. Christine Finn gave an interesting presentation on "Fifteen Years After Artifacts: An Archaeologist's Year in Silicon Valley". You can find the presentations at:

<https://www.youtube.com/channel/UCu3UDdi0lxiSaFKq-p5gYQ/videos>

David Greelish was also there. I first heard David when he was a podcaster for the Retro Computing Roundtable (RCR). David gave a presentation on "Great Moments on Film in Computer History". Thomas Haigh gave a presentation about the ENIAC and the people that worked on and with the ENIAC. Jim Brain gave a presentation on designing hardware.

Randy Kindig gave a presentation on bringing our vintage computers into the modern world. William Kustes gave a presentation titled "Computer Toys Workshop: Think-a-dot, Dr. Nim and Digi-Comp". Evan Wright gave a talk on creating a ROM Cartridge for the CoCo 2. D. Schmüdde, who worked on a documentary called "Jack and the Machine", gave a presentation on "Commodore and Jack Tramiel: Accidentally Arming a Hacker Revolution".

Jack Rubin held a panel discussion on Digital Equipment Corporation (DEC) Programmed Data Processor (PDP) Panels. So it was a panel discussion on panels. Glenn Holmer gave a presentation on "Promal Revisited".

John Linville, Neal Blanchard, and Michael Rowen of the CoCo Crew podcast were there. John Strong was there and had some new 3D printed cases to show.

The show had Commodore, TRS-80/CoCo, Sun, AT&T UNIX, DEC PDP, DEC VAX, ATARI, and RCA ELF.

There was a free giveaway pile and an auction.

This was the 11<sup>th</sup> Vintage Computer Festival Midwest.

They do not charge admission. Parking is also free. Table space is free.

They are raising money for next year's fest. If you would like to make a donation for next year's fest, you can go to their website. Their website is [vcfmw.org](http://vcfmw.org). They also have links to fest videos and pictures on the website.



I see a TRS-80 on the right side



TRS-80



This TRS-80 system has all kinds of I/O expansions





TRS-80

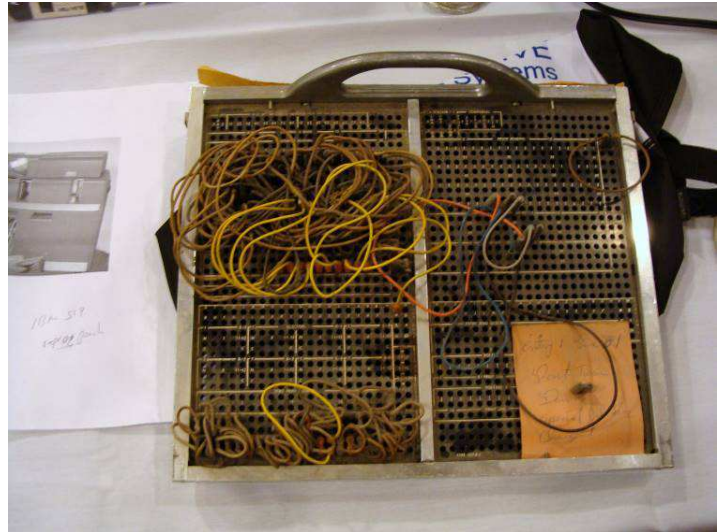

Early IBM Software for an IBM 519



CoCo

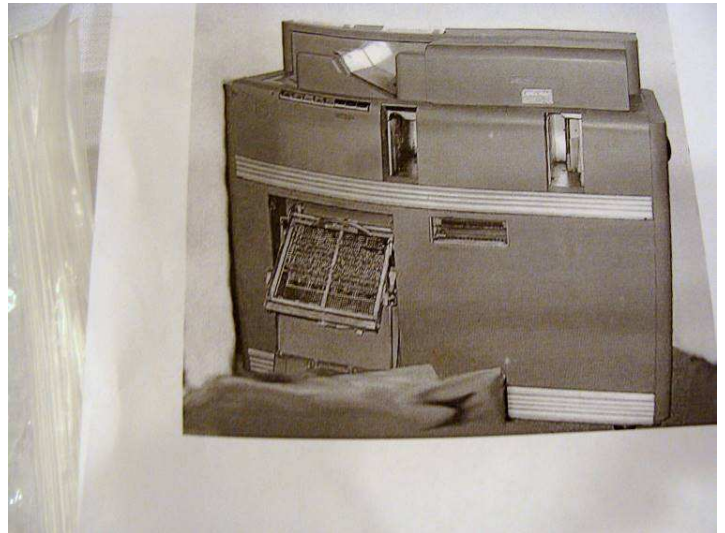

Early IBM Hardware. This is a machine to handle punched cards. This is an IBM 519.



Glenside's booth



Commodore nixie tube calculator





DEC PDP 11/70 Panel

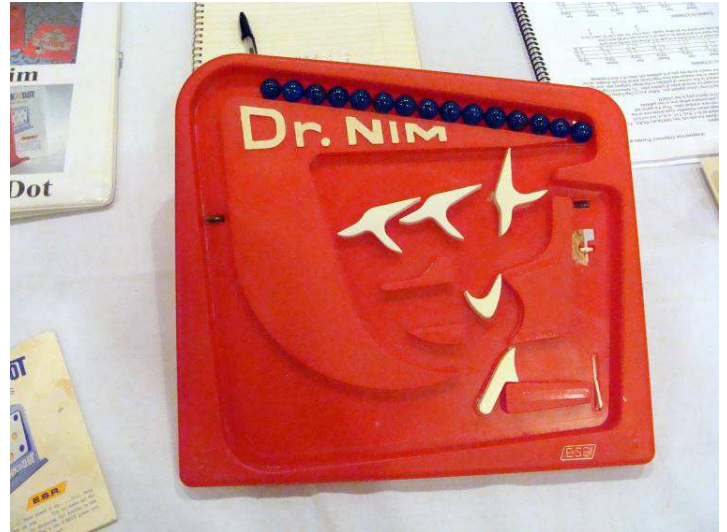

This is a gravity-powered computer



This is a DEC PDP panel. You can use it to enter, examine, and single-step your code.



An Apple II GS

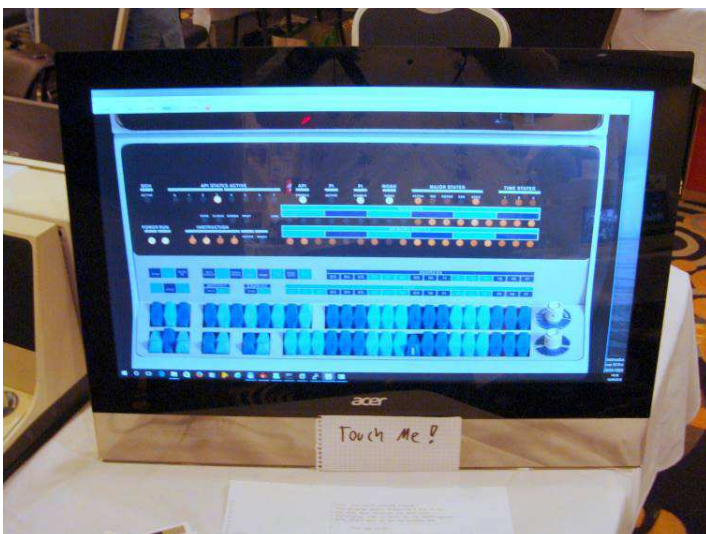

Touch screen application to emulate DEC PDP panel



A Timex Sinclair 1000 that sold for \$29 at K-Mart in 1982. A 16K RAM pack & printer were also available.





ATARI video game system



Clear case Commodore



ATARI JAGUAR

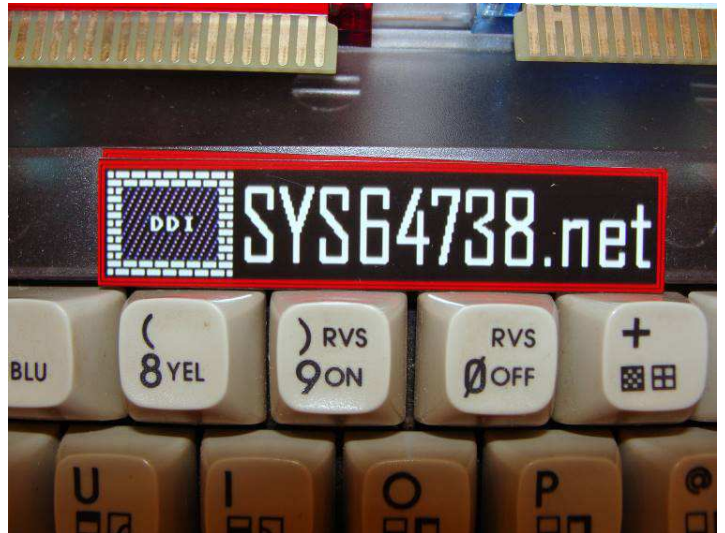

For information on a CoCo joystick adapter check out <http://www.sys64738.net/ddicja/ddicja.htm>



ATARI JAGUAR



COSMAC ELF / Retro ELF Plus with an RCA 1802 microprocessor

## Odds and Ends

by Lloyd Shotwell

I just received your newsletter and found it very interesting. I was very interested in the Color Computer in the 80's and early 90's. I had one of the early CoCo's (4K) that I upgraded and then had a CoCo3 when they came out. I had the CoCo set up in my garage and did not use it very often. I live in upstate New York and we had a flood that put about three feet of water in my garage. It ruined my computer set-up, but I do have Rainbow Magazines and Rainbow on disk plus some cartridges and also discs.

I can make an inventory of what I have and send it to you. If your club is interested in having them, I would donate them to your club, if you would be willing to pay the shipping costs.

Lloyd Shotwell - Owego NY - [lshotwell@stny.rr.com](mailto:lshotwell@stny.rr.com)



## Wikipedia Plea

by John Mark Mobley

Wikipedia is short for Wiki Encyclopedia, where "wiki" is a Hawaiian word meaning "quick". They allow ordinary people to update or add to their encyclopedia from a web interface. You can also view the information in a number of different languages. If you want to see this service remain ad-free, please consider donating to the cause. Brian Goers and others of Glenside's "inner circle" are therefore encouraging our members to consider donating time and money to Wikipedia.

Information on giving is found through the following two links:

[https://en.wikipedia.org/wiki/Wikipedia:Contact\\_us\\_-\\_Donors](https://en.wikipedia.org/wiki/Wikipedia:Contact_us_-_Donors)

[https://wikimediafoundation.org/wiki/Ways\\_to\\_Give](https://wikimediafoundation.org/wiki/Ways_to_Give)

Below is a sample of what you can find on Wikipedia:

[https://en.wikipedia.org/wiki/TRS-80\\_Color\\_Computer](https://en.wikipedia.org/wiki/TRS-80_Color_Computer)

[https://en.wikipedia.org/wiki/TRS-80\\_MC-10](https://en.wikipedia.org/wiki/TRS-80_MC-10)

<https://en.wikipedia.org/wiki/TRS-80>

<https://en.wikipedia.org/wiki/Microprocessor>

[https://en.wikipedia.org/wiki/Motorola\\_6800\\_family](https://en.wikipedia.org/wiki/Motorola_6800_family)

[https://en.wikipedia.org/wiki/Motorola\\_6809](https://en.wikipedia.org/wiki/Motorola_6809)

[https://en.wikipedia.org/wiki/Hitachi\\_6309](https://en.wikipedia.org/wiki/Hitachi_6309)

[https://en.wikipedia.org/wiki/Zilog\\_Z80](https://en.wikipedia.org/wiki/Zilog_Z80)

<https://en.wikipedia.org/wiki/Modem>

[https://en.wikipedia.org/wiki/Printer\\_\(computing\)](https://en.wikipedia.org/wiki/Printer_(computing))

[https://en.wikipedia.org/wiki/Floppy\\_disk](https://en.wikipedia.org/wiki/Floppy_disk)

[https://en.wikipedia.org/wiki/Floppy-disk\\_controller](https://en.wikipedia.org/wiki/Floppy-disk_controller)

[https://en.wikipedia.org/wiki/Disk\\_controller](https://en.wikipedia.org/wiki/Disk_controller)

[https://en.wikipedia.org/wiki/Hard\\_disk\\_drive](https://en.wikipedia.org/wiki/Hard_disk_drive)

<https://en.wikipedia.org/wiki/CompactFlash>

[https://en.wikipedia.org/wiki/Secure\\_Digital](https://en.wikipedia.org/wiki/Secure_Digital)

[https://en.wikipedia.org/wiki/Solid-state\\_drive](https://en.wikipedia.org/wiki/Solid-state_drive)

[https://en.wikipedia.org/wiki/Dynamic\\_random-access\\_memory](https://en.wikipedia.org/wiki/Dynamic_random-access_memory)

[https://en.wikipedia.org/wiki/Read-only\\_memory](https://en.wikipedia.org/wiki/Read-only_memory)

[https://en.wikipedia.org/wiki/ROM\\_cartridge](https://en.wikipedia.org/wiki/ROM_cartridge)

[https://en.wikipedia.org/wiki/Video\\_display\\_controller](https://en.wikipedia.org/wiki/Video_display_controller)

[https://en.wikipedia.org/wiki/Digital-to-analog\\_converter](https://en.wikipedia.org/wiki/Digital-to-analog_converter)

[https://en.wikipedia.org/wiki/Computer\\_keyboard](https://en.wikipedia.org/wiki/Computer_keyboard)

<https://en.wikipedia.org/wiki/Joystick>

[https://en.wikipedia.org/wiki/Analog\\_stick](https://en.wikipedia.org/wiki/Analog_stick)

[https://en.wikipedia.org/wiki/Game\\_controller](https://en.wikipedia.org/wiki/Game_controller)

[https://en.wikipedia.org/wiki/Computer\\_mouse](https://en.wikipedia.org/wiki/Computer_mouse)

[https://en.wikipedia.org/wiki/Computer\\_monitor](https://en.wikipedia.org/wiki/Computer_monitor)

[https://en.wikipedia.org/wiki/Cathode\\_ray\\_tube](https://en.wikipedia.org/wiki/Cathode_ray_tube)

[https://en.wikipedia.org/wiki/Serial\\_port](https://en.wikipedia.org/wiki/Serial_port)

[https://en.wikipedia.org/wiki/Peripheral\\_Interface\\_Adapter](https://en.wikipedia.org/wiki/Peripheral_Interface_Adapter)

[https://en.wikipedia.org/wiki/MOS\\_Technology\\_6522](https://en.wikipedia.org/wiki/MOS_Technology_6522)

[https://en.wikipedia.org/wiki/WDC\\_65C22](https://en.wikipedia.org/wiki/WDC_65C22)

<https://en.wikipedia.org/wiki/BASIC>

[https://en.wikipedia.org/wiki/Assembly\\_language](https://en.wikipedia.org/wiki/Assembly_language)

<https://en.wikipedia.org/wiki/DOS>

[https://en.wikipedia.org/wiki/High-level\\_programming\\_language](https://en.wikipedia.org/wiki/High-level_programming_language)

[https://en.wikipedia.org/wiki/Very\\_high-level\\_programming\\_language](https://en.wikipedia.org/wiki/Very_high-level_programming_language)

[https://en.wikipedia.org/wiki/Text\\_editor](https://en.wikipedia.org/wiki/Text_editor)

[https://en.wikipedia.org/wiki/Word\\_processor](https://en.wikipedia.org/wiki/Word_processor)

[https://en.wikipedia.org/wiki/Desktop\\_publishing](https://en.wikipedia.org/wiki/Desktop_publishing)

[https://en.wikipedia.org/wiki/Terminal\\_emulator](https://en.wikipedia.org/wiki/Terminal_emulator)



## Calendar of Events

by John Mark Mobley and Salvador Garcia

Glenside Color Computer Club, Inc. Business Meetings  
Thursday, January 12, 2017  
7:00 PM to 10:00 PM Central Time  
Schaumburg Public Library  
130 South Roselle Road  
Schaumburg, IL, USA  
Google Hangouts access is available via John Mark Mobley or John Linville.

Friday - Sunday March 31, 2017 – April 2, 2017  
Vintage Computer Festival East  
InfoAge Science Center  
Wall, NJ 07719  
Link: <http://vcfed.org/wp/festivals/>

Saturday and Sunday April 22-23, 2017  
The 26<sup>th</sup> Annual "Last" Chicago CoCoFEST!  
A TRS-80, Tandy, and Radio Shack computer festival  
Saturday, 9:00 AM to 11:59 PM  
Sunday, 9:00 AM to 3:00 PM  
Heron Point Building / Convention Center (Lower Level)  
Next to Fairfield Inn & Suites  
Lombard, IL 60148  
Link:  
<http://www.glensideccc.com/cocofest/index.shtml>

Friday-Sunday June 9-11, 2017  
Southern-Fried Gameroom Expo 2017  
Friday 4:00 PM – 11:59 PM  
Saturday 10:00 AM – 11:59 PM  
Sunday 9:00 AM – 3:00 PM  
Renaissance Atlanta Waverly Hotel &  
Convention Center  
Atlanta, Ga 30339  
Link: <http://southernfriedgameroomexpo.com/>

Tuesday-Sunday July 18-23, 2017  
Kansas Fest 2017  
Apple ][ Festival  
Other computer systems are welcome  
Ruckhurst University  
Kansas City, MO 64110  
Link: <https://www.kansasfest.org/>

Saturday and Sunday August 5-6, 2017  
Coleco Retro Gaming & Collectibles Expo  
New Jersey Convention and Exposition Center  
Edison, NJ 08837  
Link: <https://www.colecoexpo.com/>

Tentative October Timeframe  
Tandy Assembly  
A TRS-80, Tandy, and Radio Shack computer festival  
Chillicothe, Ohio  
Contact: John Linville at [john@cococrew.org](mailto:john@cococrew.org)

## The 26th Annual "Last" Chicago CoCoFEST!

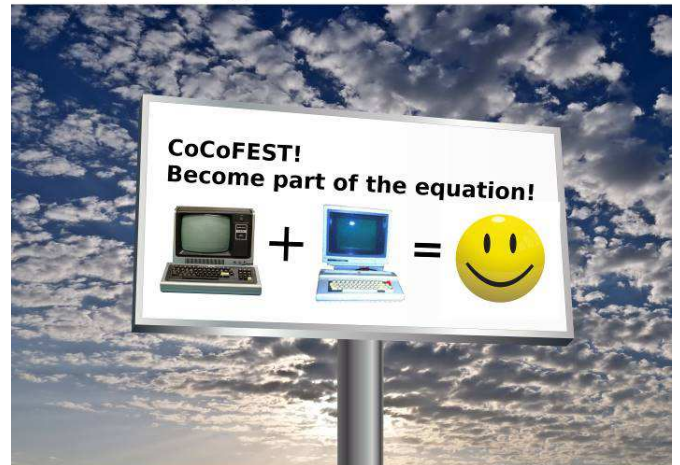

### 2017 CoCoFEST! Proudly Presented By The Glenside Color Computer Club Fairfield Inn, Lombard, Illinois

Here are the 5 "W's"

**WHO?** 1) Glenside Color Computer Club, Inc.  
**PRESENTS**

**WHAT?** 2) The 26th Annual "Last" Chicago CoCoFEST!

**WHEN?** 3) April 22 & 23, 2017

(Sat. 9 am to midnight - Sun. 9 am-3 pm)

**WHERE?** 4) Fairfield Inn & Suites Lombard

645 West North Avenue

Lombard, IL 60148

(Near the intersection of IL-355 and North Avenue)

(Same location as 2016!)

**Overnight room rate:**

\$92.00 plus 11% tax (\$102.12 Total)

Call 1-630-629-1500 for reservations.

You must ask for the Glenside "CoCoFEST!" rate.

>>> YOU MUST REGISTER UNDER "CoCoFEST!" <<<

>>> TO GET THIS RATE <<<

**WHY?** 5)

- A. To provide vendor support to the CoCo Community
- B. To provide Community support for our CoCo Vendors
- C. To provide educational support to new users.
- D. TO HAVE AN OUTRAGEOUSLY GOOD TIME!!!

And now, the "H" word.

**HOW MUCH?** All Attendees - General Admission

Both days: \$10.00 1st - \$5.00 2nd & more

Sunday Only: \$5.00 1st - \$5.00 2nd & more

\*\*\*\*\* Children 12 and under - FREE \*\*\*\*\*

For further information, general or exhibitor, contact:

Tony Podraza, GCCCI Robert Swoger, GCCCI

847-428-3576, VOICE 630-847-7026, VOICE

[tonypodraza@gmail.com](mailto:tonypodraza@gmail.com) [rswoger@aol.com](mailto:rswoger@aol.com)

Please note the new starting times, 9 AM, not 10 AM.

Be sure to visit our Website to see up-to-date information on upcoming events. <http://glensideccc.com>