

ADVENTURE SURVIVORS

24 Perthshire Drive, Peachtree City, GA 30269 (770) 487 8461 NR.38 MAY, 1996

TABLE OF CONTENTS:

- 1) CEO TALK.
RICK'S PICNIC.
CORRECTION.
NEW MEMBERS.
- 2) REVIEW: *LEISURE SUITE LARRY IN THE
LAND OF THE LOUNGE LIZARDS*
FUTURE REVIEW LIST.
- 3) PHOTOS FROM PAST CHICAGO FESTS.
- 4) LEISURE SUITE LARRY MAPS.
LSL FOR IBM COMPATIBLE USERS.
- 5) LEISURE SUITE LARRY SOLUTION.
- 6) SWAP SHOPPE.
- 7) SWAP SHOPPE 2.

CEO TALK

The 5th Annual "Last" Chicago Fest was GREAT FUN! Renewing old acquaintances and meeting new faces is always a pleasure.

There were Seminars, Glenside "auction sales" (always very popular), many Vendor "Specials" (especially late Sunday), lots of new/used CoCo software/hardware, and a number of "Door Prize" drawings. Also, a few of the 68xxx machines, OSK, and OS9 were well supported.

VENDORS AND REPRESENTATIVES

Alan Dages, R.C. Smith, Ron & Diane Bull (also represented Rick's Computer Enterprise), Chris & Nancy Hawks of Hawksoft, Carl Boll of Chicago BBS, Bill Wittman of Wittman Computer Products, Frank Swygert of Farna Systems, John & Charley Strong of Strongware, Andre Lavelle of SBUG, Tom Schaeffges of The Coco Cellar, Alan Dekok of Northern Xposure, The OS9 Users Group, Dave Pellerito of Digigrade Productions, John Brown of Hazelwood Computer Systems, Paul Jerkatis of SandV BBS, Chicago Area OS9 Users Group, Justine Wagner of Justin Time, Brother Jeremy of Monk-O-Ware, The Glenside Club, and Adventure Survivors.

Fest attendance, and the number of vendors were down from last year. BUT, Glenside has announced that there will be another Chicago Fest next year - probably the first week-end in April.

A SPECIAL THANKS to the Ladies, and Gentlemen - Especially Tony Podraza, and Carl Boll - of Glenside. Their efforts in keeping CoCo support alive is greatly appreciated - WELL DONE!!!

RICK'S PICNIC

SPONSOR: Rick's Computer Enterprise.
P.O. Box 276

Liberty, KY 42539
606 787 5783

WHEN: Saturday July 13, 1996.

8 AM - 6 PM: Demos, Sales, Seminars, etc. Coffee, soft drinks, sandwiches, and snacks are available.
6:30 PM - Catered Picnic.

AFTERWARDS: Visit Rick's house, CFDM Headquarters, and more!

WHERE: Liberty, KY at The Douglas Elementary School - about 6 miles NW of Liberty, State Highway 49 (same place as last year). If you wish, gather at the Brown Motel 7:45 AM (Sat. morning) for a "Convoy" to the School.

TICKETS: \$20 each.

RESERVATIONS: Make your own at ...

Liberty: The Brown Motel
606 787 6224

Russell Springs: 20 miles south.
Cumberland Lodge
502 866 4208

Danville: 30 miles north.
Days Inn (& others)
606 236 8601

(these Cities are on US HWY 127)

Last year was GREAT! We plan to be there again this year.

Rick Cooper has also just started *THE COCO REPORT*, a new quarterly Newsletter for \$7. It will contain a wide variety of CoCo material - a WORTHY Publication!

CORRECTION

A PCFDM "sampler" from Rick's Computer Enterprise is available for \$2, OR send a SAS disk mailer, and a 3 1/2", 1.44 disk.

NEW MEMBERS: Welcome to the Club!

SrA D. Concepcion of Tyndall AFB, FL.
Stefan Topolski of Eden, MD.
Luis E. Tanon of Bayamon PR.
Michael Shell of Augusta GA.

**REVIEW: LEISURE SUIT LARRY IN THE LAND OF
THE LOUNGE LIZARDS**

LSL is another fine graphic adventure from *SIERRA ON-LINE* by Al Lowe & others. Of course, the CoCo version is no longer available. Even used ones are difficult to find. A 512K CoCo 3, disk drive (two are better), and RGB or CMP (TV) monitor, are required. For IBM compatible users, see article at the bottom of page 4.

NOTE: Due to content, LSL is "RATED PG" - may not be suitable for youngsters!

It was reviewed in *Rainbow* 10/89, page 98 by John Hebert (has a picture of the start scene).

The original game package includes the game Booklet, 2 Reference Cards (one for the CoCo), and 2 un-protected disks. Back up these disks under BASIC or OS-9.

Disk 1 "flippie": Side 1, boot
(includes OS-9 loader).
Side 2, play side.

Disk 2 "floppie": Side 1, play side.

A separate Save disk MUST be formatted under OS-9. If you don't have or use that System, a disk can be formatted (or back-up the game disks) at the "OS9:" prompt when loading the game.

To load LSL (RSDOS 1.1 or 2.1), put side 1, disk 1 into drive 0, and <DOS>. Press ENTER to by-pass the "Time?" entry, and the "OS9:" prompt will appear. Now...

FORMAT A SAVE DISK

Put a spare disk in drive 0 (or drive 1): <format /d0>. For drive 1, change the "0" to a "1". Follow the on-screen prompts, and the "OS9:" prompt returns.

Continue loading (side 1, disk 1 in drive 0) with: <sierra-r> for a RGB monitor, or just <sierra> for TV or CMP monitor (during play, a special command, CTRL-V, can be used to "toggle" between monitor types). A joystick option, intro-screen, music, and a few credit screens appear. Next, you will given a test (5 trivia, general knowledge questions) that determines if you are old enough to play the game. Miss two, and you fail (OS9 prompt appears)! Re-boot, and try again OR: ALT-SHIFT x (at the test or intro-screen) for a quicker start, and by-pass the quiz). One way or the other, You'll will be prompted to "turn" the disk, and press the Enter key to begin play.

Two word (verb-noun), one word, and simple sentences (sometimes required) are useable commands. Type them in at the

cursor - bottom of the screen. All words must be completely typed-out, except INV (Inventory). Other useable words: IN, AT, THE, TO, etc. "Special Commands" are in the game doc's, and on page 4 (they auto-exec when touched).

Game responses, and messages appear in "pop-up" windows. These, while on screen, act like a game pause. Return to normal play by pressing the joystick Fire-Button or the Enter key.

Move your character, Larry, around via a joystick (easier), or combinations of CTRL or SHIFT keys with the Arrow keys. A few places require travel via a Taxi cab. Move Larry to the Street edge (middle of a scene) and <HAIL TAXI> or just <CAB>. When it stops, move closer and <GET IN>. The Driver asks where to? Reply: <STORE>, <CASINO>, etc. When you arrive, he says how much it is (random, \$6-20). <PAY> and <EXIT>. ALWAYS have enough money to pay! Score one point for the first cab ride.

The Save feature is excellent. <SAVE GAME> or touch the 5 key and follow the on-screen prompts. If you use drive 1 for the Save disk, then change the "/d0" to "/d1" (back-space with the left-arrow key to remove the "0", touch "1", and press ENTER). Describe your save position anyway you wish, within 30 "spaces".

Other Tips: <USE SPRAY> when your "Bad Breath" is mentioned. Move away from the Dog or be "anointed". Don't <FLUSH THE COMMODORE>! Don't let your money reach \$0 (Larry hides \$10 - seems useable, only once during normal play). Don't stay in a "Dark Alley" more than a few seconds! Be sure to USE, and REMOVE "protection" when dealing with the hooker. LSL can be finished by scoring less than 222 points.

TASK: Help Larry lose his virginity, and find True Love in "Lost Wages".

FUTURE REVIEW LIST

JUL'96 (1) ADVENTURELAND *
SEP'96 (3,3) ROGUE *
NOV'96 (2) BALLYHOO
JAN'97 (2) INDIANA JIM
MAR'97 (4,6) SEASTALKER
MAY'97 (3) ALCATRAZ
(3) ZORK II
(4) ZORK III
(4) CASTLE OF THAROGGAD *
(5) MIS-ADVENTURES OF EDDIE *
(5) TARZAR 2 *

(n): Member Choice number(s).

* : We haven't played or finished these.

George Schneeweiss

Barbara Williams

Brother Jeremy

Tony Podraza

Phil...

Nan Padgett

Chris Podraza

Rob Gibbons

Tom Schaeffges

Frank Swygert

Linda Podraza

Brian Schubring

Paul Knudsen

John Chasteen

Bob Swoger

Eddie Kuns

Betty Willis

Alan Dages

Tony Podraza

Chris Hawks

Andre Lavelle

R.C. Smith

Linda Podraza

Carl Boll

Alan Dekok

Tom Schaeffges

PHOTOS BY Dave Barnes

Al & Babs Dages

Nan & L.E. Padgett

Tom Kolwalski

Scott Griedentrog

Charley Strong

Sheryl Edwards

Fourth Annual "Last" Chicago Co-Op 1995

LEISURE SUIT LARRY MAPS

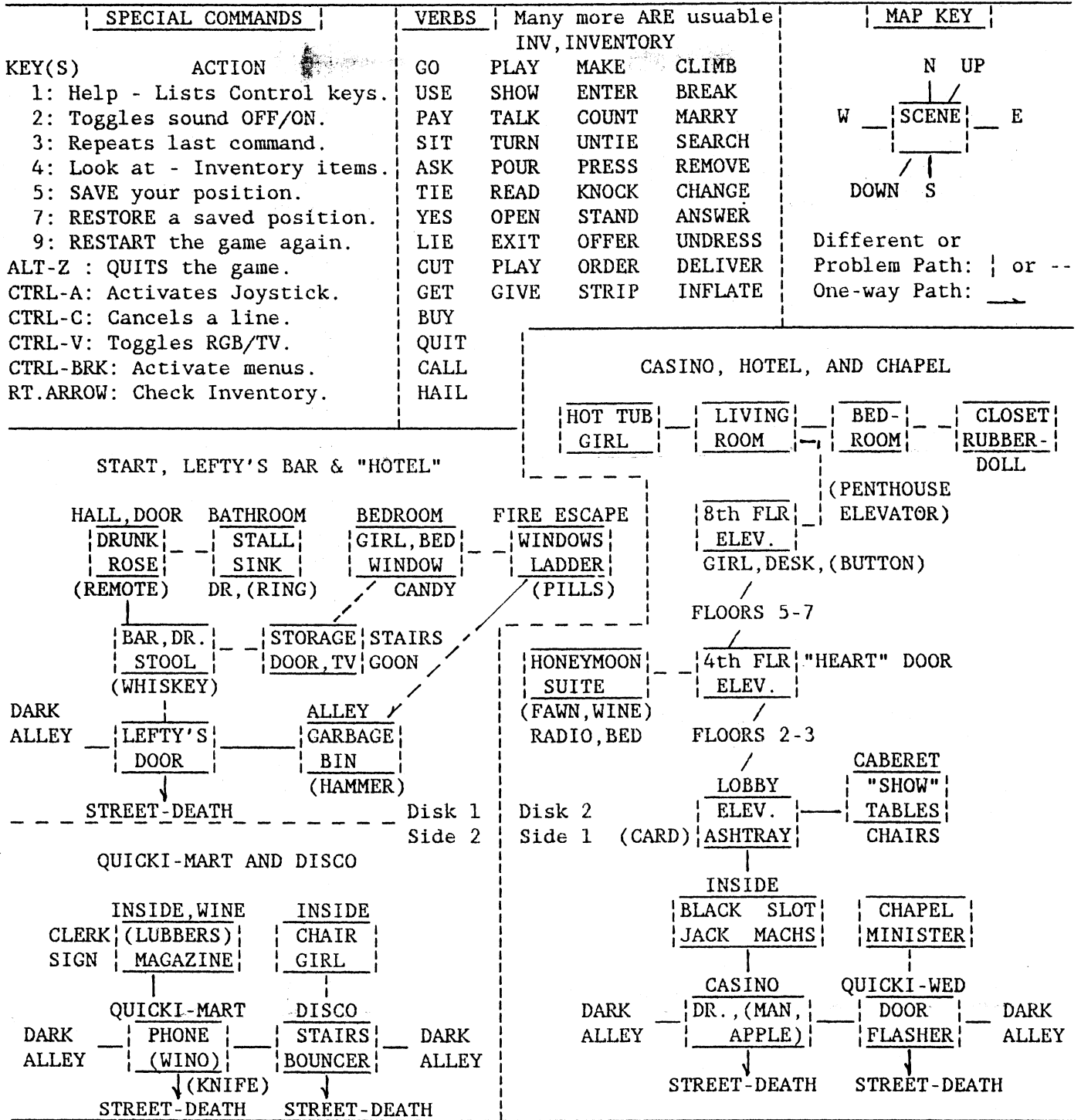

For IBM Compatible users: Sierra recently offered *Leisure Suit Larry I: In The Land of The Lounge Lizards*, and a few others, on CD ROM (MSDOS) for \$14.95. ORDER (credit card) #: 1 800 757 7707. Basically it plays the same, but colors, graphics, (non-stop) music, animation, and 3-D effect are much better. It is icon driven (point-click with a mouse), and plays faster. Maximum total points is still 222. "Click" on the "system" icon to see your running total. Other differences: 1. Whenever You earn a point, you'll hear a "ding". 2. Call Sierra (209 683 6858) early (first time at the Store?) for that 5 points. 3. The point in the Cabaret is only given when the Comic is there. 4. No bet limit (Black Jack or Slots) and \$10,000 Breaks-the-Bank. 5. No point for looking at the girl (Fawn) in the Disco, but You get 2 points for turning on the radio in the Honeymoon Suite instead of 1. 6. A "Zipper" icon is available.

LEISURE SUIT LARRY SOLUTION

This shows one way to solve the problems, and score 222 points. Earned points, running totals, and comments are shown in parentheses. Commands are shown in UPPER-CASE, and generally, scenes are underlined. LOOK in each scene for a good description.

LEFTY'S: INV. LOOK WALLET (\$94). READ BUSINESS CARDS (phone #209 683 6858). (door) OPEN DOOR. (Bar, stool) SIT. BUY WHISKEY (1-1). STAND. (Hall, table) GET ROSE (1-2). (drunk) GIVE WHISKEY (2-4, you get a remote control). (door) OPEN DOOR. (Bathroom, stall) SIT (1-5). STAND. (sink) LOOK SINK. GET RING (3-8). READ WALL (until "Ken Sent Me", 2-10). (Bar, east door) KNOCK. KEN SENT ME. (Storage Room) USE REMOTE (3-13). CHANGE CHANNEL (until the goon moves, 8-21). (Bedroom, girl business later, table) GET CANDY (2-23). (window) OPEN WINDOW. CLIMB OUT. (Fire Escape, east side) LOOK WINDOW (pills, later. west, in the garbage) GET HAMMER (3-26). EXIT. (west, catch a cab to the store (1-27).

QUICKI-MART: LOOK PHONE (1-28, #555 6969). USE PHONE. 555 6969 (2-30, "sex survey". Answer each question anyway you wish). USE PHONE. 209 683 6858 (5-35, Sierra pitch. Ignore the Wino if he appears - need the wine. (Inside, magazine rack) GET MAGAZINE (1-36). READ MAGAZINE (1-37, rope clue). (rear of store) GET WINE (1-38). (counter) READ SIGN. LOOK CLERK. TALK CLERK. BUY PROPHYLACTICS (answer the "choice" questions, 4-42). (Outside) GIVE WINE TO WINO (5-47, you get a knife). (phone rings) ANSWER PHONE (5-52, survey result. Catch a cab to the Casino).

CASINO: (If the man shows up, random) BUY APPLE (3-55). (Lobby) LOOK ASHTRAY. GET CARD (1-56). LOOK CARD. (Caberet, lower-right chair) SIT (1-57). STAND. (Casino, black-Jack table, lower-left) SIT. (you can play the slots, but the odds are better at black-jack) CHANGE BET. 20 (maximum. Save the game. Do nothing for 15 seconds, the "rules" will be shown. If you win, save the game. If you lose, restore. Play until you Break-the-Bank, \$250. Leave, and catch a cab to the Disco).

DISCO: (bouncer) SHOW CARD (5-62). (Inside, girl) SIT (1-63). LOOK GIRL (1-64). ASK GIRL TO DANCE. STAND (Follow her to the dance floor, auto-dance, and follow her back to the table, 5-69). SIT. LOOK GIRL. TALK GIRL (1-70, until "Oops"). GIVE ROSE (5-75). GIVE CANDY (5-80). GIVE RING (5-85, you agree to marry, and Fawn needs \$100). GIVE MONEY (7-92, she leaves for the Chapel. Catch a cab to the Chapel).

QUICKI-WED CHAPEL: (flasher) TALK FLASHER (1-93). (Inside, altar) MARRY FAWN (12-105, another \$100. Fawn goes to the Honeymoon Suite. Follow her, next door).

LOBBY: (elevator) FOUR. (4th floor, "Heart" door) KNOCK. (Inside, radio) TURN RADIO ON (1-106, "Ajax", 555 8039. Fawn wants wine. Check your money. If you don't have \$50 +, Play black-jack until you do. Catch a cab to the Store). USE PHONE. 555 8039. WINE. HONEYMOON SUITE (5-111, back to the Honeymoon Suite). (near Fawn) POUR WINE. MAKE LOVE TO FAWN (You're tied to the bed, robbed, and Fawn leaves). USE KNIFE (10-121). GET ROPE (3-124. Casino, build your money to over \$50, and Catch a cab back to Lefty's).

LEFTY'S: (Bedroom, south side of the bed) UNDRRESS. USE PROPHYLACTIC (10-134). MAKE LOVE TO GIRL (11-145). REMOVE PROPHYLACTIC (1-146). (window) CLIMB OUT. (Fire Escape, east side) TIE ROPE TO WAIST. TIE ROPE TO RAIL. GET PILLS. BREAK WINDOW. GET PILLS (8-154). CLIMB BACK. UNTIE ROPE (west, in the garbage). EXIT (west, Catch a cab to the Casino).

CASINO: (8th Floor, desk) LOOK GIRL. TALK GIRL (until Medical Stimulant is mentioned). GIVE PILLS TO FAITH (5-159, she leaves). LOOK DESK. PRESS BUTTON. (enter the "Gold" elevator, 5-164, auto-to the Penthouse. Move around a partition to a door in the Bedroom). OPEN DOOR. (Closet) LOOK. GET DOLL (5-169). INFLATE DOLL (5-174). MAKE LOVE TO DOLL. YES (8-182, the doll burst, floats Outside, and you auto-follow). (Hot tub) UNDRRESS. LOOK GIRL. LOOK BRACELET (Eve). POUR WINE. TALK EVE (until she repeats herself). GIVE APPLE (15-197. Auto-end, you go to the bedroom, music, fireworks (25-222), congratulations, another Sierra commercial, and the OS-9 prompt reappears.

ADVENTURE SURVIVORS SWAP SHOPPE

MAY 1996

MEMBERSHIP AND SHIPPING FEES:

Memberships: U.S. mail addresse ----- \$7
 Canada mail addresses --- \$8
S&H Fees: All addresses. One package
 (Program, Combo, or 6 Back-Issues) -- \$2
 Each additional Package/order, ADD -- \$1
Maximum S&H for each ORDER ----- \$6
BACK-ISSUES only: Each 3 B.I.'s ----- \$1

GRAPHIC ADVENTURES

POWER STONES OF ARD (Ard I) ----- \$12
 Includes our Preliminary
 Information and the NEWLIFE pgm.
POWERSTONES OF ARD II (Ard II) -- \$17
 Both Ards -- \$27
TOMB OF T' IEN & MR. COREY, each -- \$ 7
 All CoCo's, CMP (TV)
HONOR QUEST CoCo3, J-S, RGB/CMP - \$10
TEXT ADVENTURES
 Disk vers., All CoCos, Save Feature.
ADVANCED ADVENTURE COMBO -- \$11
ATLANTIS KINGDOM OF BASHAN ALCATRAZ
MEDIUM ADVENTURE COMBO --- \$11
ESPIONAGE ISLE CUBE ADV. 4 MILE ISLE
STARTER COMBO ----- \$11
MY HOUSE PIRATES ADV. SNAKES (arcade)
 !! CASTLE OF THE CREATOR !!
FREE text adv. with any COMBO order!!



SMALL GRAFX

ETC.

NEW - THE TOOL - NEW

512K Upgrades \$50.00
 Hitachi HD63B09E CPU & Socket \$13.00
 "Y" / "TRI" Cables Made Special 40 pin
 Male or Female connectors EA \$ 6.50
 Rainbow 40 wire ribbon cable min./ft \$ 1.00
 2400 Baud External Modem (Brand New) Hayes-
 compatible Class 5 Mnp...\$30.00 / Cable.....\$5.00
 CGP-220 Printer Version 6.0 Eprom
 Bold Print) \$10.00
 CGP-220, PJ-1080A, QuadJet Printer Special Ink
 Refill Kit.....\$50.00

*** THE TOOL ***

Graphic Manipulator Program.....\$15.00
 13 screens in 512k --Full Screen Flips, Zooms
 Shrinks, Swaps, Palette Changes, Stamps, Scroll
 Memory, Multiple Printer Support, Save, Load
 Portrait(2), Landscape(3) Sizes, Double Height, Side by Side
 S&H \$3.00 1st Item-\$1.00 ea Additional
 SERVICE, PARTS, HARDWARE AND OPHIRANWARE / TANDY
 SOFTWARE AVAILABLE ALL WITH COMPLETE DOCUMENTATION.
 ALSO, CANNON, HP INKJET REFILL KITS, AND PRINTERS RIBBONS
TERRY LARAWAY 41 N.W. DONCEE DRIVE
BREMERTON, WA 98311 360-692-5374

\$5 OFF on the modem purchase -
 mention you are an A.S. Member.

BACK ISSUES: \$1 each or 6 for \$5

1. Aug '90. **MADNESS & MINOTAUR** k ---- T, D
 2. Sep '90. **WORLD-CARMEN** k ----- D3
 SIR RANDOLPH - MOORS ---- T, D
 3. Oct '90. **DUNGEONS OF DAGGORATH** -- Pgpk
 DAGGORPATCH ----- D
 4. Nov '90. **PYRAMID 2000, BEDLAM** ---- T, D
 5. Dec '90. **LANSFORD MANSION** ----- D
 ONE ROOM ----- T, D
 6. Jan '91. **WIZARD'S CASTLE** k ----- D
 7. Mar '91. **WILDWEST** ----- D3
 SILVERTON HOUSE ----- T, D
 8. May '91. **RAAKA-TU- T, D, SANDS-EGYPT-** D
 9. Jul '91. **INTERBANK INCIDENT** k ----- D
 10. Sep '91. **DALLAS QUEST** ----- D
 SIR RANDOLPH RETURNS ----- T
 11. Nov '91. **KEYS OF THE WIZARD** k ---- T, D
 12. Jan '92. **KING'S QUEST III** ---- 512K, D3
 13. Mar '92. **RIDDLE OF THE RING** ----- D
 BLACKBEARD'S ISLAND ----- D
 14. May '92. **THE CONTROLLERS** ----- T3, D3
 MAGIC OF ZANTH ----- D3
 15. Jul '92. **WISHBRINGER** ----- D
 HALL OF THE KING III ----- D
 16. Sep '92. **HITCHHIKERS GUIDE** ----- D
 HALL OF THE KING ----- D
 17. Nov '92. **CALADURIL 2** ----- D3
 18. Jan '93. **TO PRESERVE QUANDIC** ----- D
 HALL OF THE KING II ----- D
 19. Mar '93. **MARTIAN CRYPT** ----- T, D
 CALIXTO ISLAND ----- T, D
 20. May '93. **CALADURIL** ----- D
 21. Jul '93. **QUEST OF THE STARLORD** ---- D3
 WHITE FIRE OF ETERNITY ---- D
 22. Sep '93. **ADV. IN WONDER LAND** ---- T, D
 DRAGONBLADE ----- D
 23. Nov '93. **VORTEX FACTOR** ----- T, D
 PLANETFALL ----- D
 24. Jan '94. **WITNESS-D, BLACK SANCTUM-** T, D
 25. Mar '94. **SYZYGY --- T, D, ZORK I** ---- D
 26. May '94. **MAJOR ISTAR-D, SEA QUEST-** T, D
 27. Jul '94. **TERM PAPER- D3, TREKBOER-** T, D
 28. Sep '94. **LIFE- D3, SHENANIGANS --- T, D**
 29. Nov '94. **CASTLE OF THE CREATOR** ---- D
 ARD I Preliminary Info --- D3
 30. Jan '95. **CUBE** ---- D, **ATLANTIS** ---- D
 31. Mar '95. **MICKEY'S SPACE ADVENTURE** -- D
 32. May '95. **KARRAK- T, STOP COLOSSUS -** D3
 33. Jul '95. **ENCHANTER** ----- D
 POLYNESIAN ADVENTURE ---- T, D
 34. Sep '95. **BASHAN - T, D, GALAXY #1 -** T, D
 35. Nov '95. **MR. COREY - D, GALAXY #2 -** T, D
 36. Jan '96. **KORONIS RIFT** ----- D3
 37. Mar '96. **INFIDEL --- D, TARZAR --- T, D**
 38. May '96. **LEISURE SUITE LARRY - 512K, D3**
 k Includes WORKSHEET.

SWAP SHOPPE 2

If you have "things" you would like to sell, make up a list, and send it in. We'll publish your Ad - NO CHARGE, just a paragraph or two OR a FULL PAGE - as space permits, ANY TIME! List your name, address, phone number (best times to call), and price(s).

King's Quest III (5 "flippies"), and Leisure Suite Larry (1 "flipper", and 1 "floppy") require a 512K CoCo 3. NOTE: KQ3 order (except the "no doc's, Misc. sets") includes 3 DS/DD disk back-ups, addressed as just 3 sides during play! Requires: double-sided disk-drive.

SUGGESTION: Call! Reserve you order - NOT MANY DUPLICATES!
Otherwise, First Come, First Serve!

"*": Includes playable, back-up disk(s). "pk": Program Pack.

--- NEW GROUP ---

2 *Dungeons Of Daggorath (pk)* - \$3.	1 *King's Quest III* ----- \$6.
1 Spactaculator (pk) ----- \$2.	1 Rescue on Fractalus.----- \$4.
3 *Shanghai(pk)* ----- \$3.	1 D.Duck's Playground ----- \$3.

--- "Gently" USED GROUPS ---

PROGRAM PACKS, All CoCos

3 *Dungeons of Daggorath* ----- \$2.	1 Mind Roll ----- \$2.
2 Personal Finance II ----- \$2.	1 Type Mate ----- \$2.
1 Spectaculator ----- \$1.	2 Color File II ----- \$2.

--- DISK BASED, CoCo 1, 2 ---

1 Ghana Bwana ----- \$2.	1 One On One ----- \$2.
1 Pitfall II (disk, no doc's) -- \$2.	1 Flt. Sim. 1 ----- \$2.

NOTE: Patch included - GB, PII, and OOO - for CC 3 use, and RGB colors.

--- Requires CoCo 3 ---

1 Carmen Sandiego (No Almanac, but will include our Review) ----- \$3.	1 Koronis Rift ----- \$3.
1 Power Stones Of Ard ----- \$5.	1 Rogue ----- \$3.
1 Power Stones of Ard II ----- \$5.	1 *King's Quest III* ----- \$5.
1 Rescue on Fractalus ----- \$3.	1 Flight Simulator II ----- \$3.
1 La Belle Lucie, solitaire ---- \$3.	3 *Shanghai* (pk) ----- \$2
1 Microscopic Mission ----- \$2.	

--- All CoCos ---

1 *Raaka-Tu*, <u>Tape</u> , No docs., but will Include our Review ----- \$2.	1 Daggorpatch, Rqs: DOD pk, DD, and MPI, Slot Pack or recorder ---- \$3.
1 Tandy, Cash Budget (<u>S&H</u> : \$4) - \$3.	1 Sub-Etha, Checkbook ----- \$3.
1 Interbank Incident ----- \$3.	1 Robot Odyssey ----- \$3.
2 Cave Walker ----- \$3.	1 Biosphere ----- \$2.
1 Infidel disk, no doc's ----- \$3.	1 Riddle of the Ring ----- \$3.
1 Hitchhikers Guide...Galaxy --- \$5.	1 Witness ----- \$5.
1 Wishbringer ----- \$5.	1 Enchanter ----- \$5.

--- OS-9 Stuff, \$3 each ---

1 Desk Mate 3 for lvl 2, Reference Card, 2 disks, no manual.	1 OS9 Profile	3 Dynacalc
2 Basic 09, lvl 1		

--- Miscellaneous disks, no doc's, \$2 each (except KQ3) ---

2 King's Quest III, 5 flipper disks. Each set (<u>S&H</u> : \$2.) ----- \$3.	
1 OS9 lvl 1 Boot, and System Master (2 disks).	
1 512k Memtest, Demo, Ramdisk, Print (buffer).	1 Fast Dupe 2.0
1 Rogue	1 Rescue on Fractalus
1 Robot Odyssey	1 Flight Simulator II
	1 Sands of Egypt
	1 Musica Ram Disk

S&H: ALL MAILING addresses: Maximum S&H per order ----- \$6.

Any one program, package (Except Tandy Cash Budget. S&H \$4.) ---- \$2.

Each additional program/order (Except KQ3 no docs set. \$2), ADD - \$1.

S&H for one, two, or set of two - no doc's disk(s) ----- \$1.