

May 1982
USA \$2.95 (UK £1.80)

80 Microcomputing

5/82

#29

80

microcomputing™

the magazine for TRS-80 users

A WAYNE GREEN PUBLICATION

Microcomputer Art— Inspiration or a New Scam?

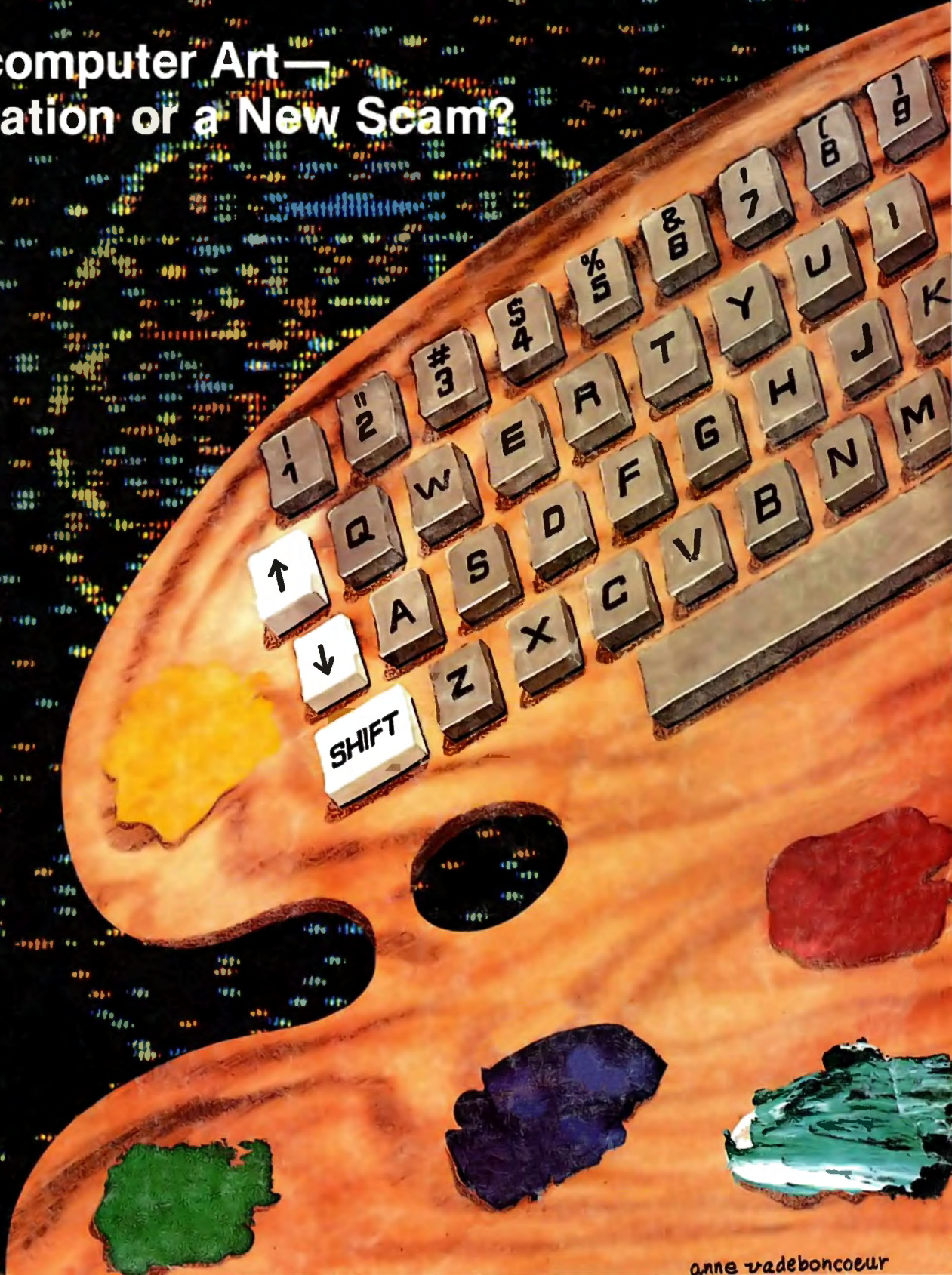

anne vadeboncoeur



Dosplus shifts into overdrive for business.

THE NEW DOSPLUS 4.0 HARD DRIVE SYSTEM MEANS BUSINESS

MAKE A SWIFT SHIFT The DOSPLUS 4.0 Hard Drive System turns your TRS-80 into a powerhouse for business applications. Shifting up to a hard drive is just like moving up from tape to floppy. It makes good business sense. You get the power, the dependability, the speed and capacity of a hard drive to power the software you need to keep your business in top gear.

MIND YOUR OWN BUSINESS The power potential of the TRS-80 driven by DOSPLUS 4.0 Hard Drive System lets you mind your own business just like the big companies do. You can control accounts receivable, accounts payable, inventory, payroll, invoicing and a whole lot more accurately and with confidence because DOSPLUS 4.0 is the only current operating system designed from conception for hard disk operation.

DOSPLUS 4.0 T.C.B. (Takes Care of Business) What good is a DOS if you have to spend so much time getting it to perform properly that your business suffers? The DOSPLUS Hard Drive System takes care of the computer while you take care of your business. It's a smooth, swift and silent business partner with the potential to handle up to 40 megabytes of capacity in 4, 10 meg units.* So now you can shift your TRS-80 into over drive with DOSPLUS.

THE DOSPLUS 4.0 FEATURES

- Single volume addressing/Double sided floppies seen

as one drive—Any single file can expand to limit of hard drive (up to 10 meg.)

- Hard disk—disk editing utilities • Incredible I/O speed
- Runs any combination of densities or tracks
- Also operates 8" drives with special hardware—comes with expanded users guide and complete DOS technical section on I/O calls and DCB organization
- "PLUS" ALL OF THE SENSATIONAL NEW DOSPLUS 3.4 FEATURES

THE DOSPLUS 4.0 HARD DRIVE SYSTEM

- Smooth, silent, swift • Error-free disk I/O
- *Add on up to 4, 10 meg units for a total of 40 megabytes!
- Plugs on the 50 pin data bus.—no loss of floppy drives
- Completely self-contained—just plug it in and go
- *10 meg units available Soon.

NOTE: Specify 40 or 80 track when ordering DOS diskette. After initial bootup, user can create any DOS desired.

STARTING FROM
TAKE YOUR \$2995 COMPLETE
MICRO TO THE MAX.

Lifetime warranty on original media.

For more information Reader service card 384

DOSPLUS

DOSPLUS first in quality!
First in the industry!



**Micro Systems
Software, Inc.**

Specializing in the Tandy Line
5848 Funston Street
Hollywood, FL 33023

(305) 983-3390

Outside of Fla. CALL TOLL FREE

1-800-327-8724 ext. 204

**FOR VISA/MASTERCARD/C.O.D. ORDERS
TOLL FREE LINES WILL ACCEPT ORDERS ONLY!**

For Applications and Technical information,
call (305) 983-3390 or drop us a card

Dealers inquiries invited

So Far, So Good...



**Your Model III is a fine computer.
So why settle for less than
a fine disk storage system?**

A fast, reliable disk storage system — no other device is so vital to the satisfactory performance of your computer. At Percom we build quality, high-performance disk drive systems. From gold-plated connector contacts to goldcad metal chassis structures. From proven design through 100% reliability testing. Percom disk systems are the standard by which others are judged — the industry's "gold standard," in a sense. And since Percom is the largest independent manufacturer of disk systems for microcomputers, you get Percom quality at very competitive prices. Add-on drives for TRS-80* computers start as low as \$399. Complete first-drive systems for the Model III start at only \$599. Put a quality Percom mini-disk storage system in your Model III. And save.

#1 For Your Model III

Percom TFD drives for your TRS-80* Model III computer are available in 40- and 80-track versions with single or dual heads. Single-head 40-track drives store 180 Kbytes; dual-head 40-track drives store 360 Kbytes. Eighty-track drives store slightly over twice these amounts. Of course these are formatted capacities. The Percom Model III controller handles up to four drives so it's possible to access almost three million bytes of on-line program and data files. You get Percom's OS-80/III Basic language DOS with each first-drive system, and your first drive may be either internal (add-in) or external (add-on). Percom TFD drives work with Model III TRSDOS and other Model III disk-operating systems. First-drive systems are pre-assembled. Installation is accomplished with simple tools.

#1 For Your Model I, Too

Percom TFD add-on drives for the TRS-80* Model I computer are available with the same features and the same quality control measures as TFD Model III drives. As for Model III drives, all Percom Model I drives are double-density rated. Install Percom's popular DOUBLER II in your Model I Expansion Interface and upgrade your Model I to provide the same storage capacity as the Model III.

Watch for Announcement of Percom's Low-Cost Hard Disk System for the Model III!

To order, or for the name of your authorized Percom retailer,
call toll free 1-800-527-1222.



PERCOM DATA COMPANY, INC.
11220 Pagemill Road • Dallas, Texas 75243
(214) 340-7081

**The Drive People
You get more out of
Percom disk systems.
Expect it!**

PRICES AND SPECIFICATIONS SUBJECT TO CHANGE WITHOUT NOTICE.

*TRS-80 is a trademark of Tandy Radio Shack Corporation which has no relationship to Percom Data Company, Inc.
PERCOM, DOUBLER II and OS-80/III are trademarks of Percom Data Company, Inc.



**Yes...I'd like to know more about
the best for my TRS-80 computer.
Send me free literature about
quality Percom products.**

MODEL I MODEL III

Send to
PERCOM DATA COMPANY, INC. Dept. 8-M
11220 Pagemill Road, Dallas, TX, 75243

NAME _____

STREET _____

CITY _____ STATE _____

ZIP _____ PHONE NUMBER _____

80 Contents

PUBLISHER/EDITOR
Wayne Green

EXECUTIVE VICE PRESIDENT
Sherry Smythe

ASSISTANT TO PRESIDENT
Matt Smith

GENERAL MANAGER
Debra Boudrieau

ASSISTANT PUBLISHER
Jeff DeTray

COMPTROLLER
Peter Correia

CIRCULATION

Patricia Ferrante, Circulation Manager;
Ginnie Boudrieau, Bulk Sales Manager

ADVERTISING, 603-924-7138

Penny Brooks, Coordinator; John Gancarz,
Hal Stephens, Susan Martin; Sales,
Marcia Stone, Office Manager.

New England Advertising Representative:
John A. Garland, Garland Associates, Inc.,
Box 314 SHS, Duxbury, MA 02332.
617-934-6464.

PRODUCTION

Nancy Salmon, Manager; Michael Murphy,
Assistant. Frances Benton, Betty Butler,
Matthew Hale, Theresa Ostebo, Scott
Philbrick, Dianne Ritson, Deborah Stone,
Irene Vall; Ad Coordinators: David
Wozmak, Judy Wimberly; Advertising
Production: Steve Baldwin, Fiona Davies,
Bruce Hedin, Jane Preston.

PHOTOGRAPHY

Sandra Dukette, Bryan Hastings, Thomas
Villeneuve, Robert M. Villeneuve

TYPESETTING

Melody Bedell, Sara Bedell, Debbie
Davidson, Michele DesRochers, Jennifer
Fay, Anne Rocchio, Kelly Smith, Lisa
Steiner, Karen Stewart

DESIGN

Denzel Dyer, Howard Happ, Laurie
MacMillan, Joyce Pillarella, Diana Shonk,
Susan Stevens, Donna Wohlfarth.

80 Microcomputing (ISSN 0199-8789) is published 12 times a year by 1001001 Inc., 80 Pine St., Peterborough, NH 03458. Phone 603-924-9471. Second class postage paid at Peterborough, NH, and additional mailing offices. Subscription rates in U.S. are \$25 for one year and \$53 for three years. In Canada, \$27.97—one year only. U.S. funds Canadian distributor Micro Distributing, 409 Queen St. West, Toronto, Ontario, Canada M5V 2A5. BC Canadian distributor: Graymar Data Services, Ltd., #4 258 E. 1st Ave., Vancouver, BC V5T 1A6. Foreign subscriptions (airmail), \$44.97—one year only. U.S. funds drawn on a U.S. bank. Foreign subscriptions (air mail), please inquire. In South Africa contact 80 Microcomputing, P.O. Box 782815, Sandton, South Africa 2146. All U.S. and Canadian subscription correspondence should be addressed to 80 Microcomputing, Subscription Department, P.O. Box 981, Farmingdale, NY 11737. Please include your address label with any correspondence. Postmaster: Send form 3579 to 80 Microcomputing, Subscription Services, P.O. Box 981, Farmingdale, NY 11737.



Paid Audited Circulation

Manuscripts are welcome at 80 Microcomputing, we will consider publication of any TRS-80 oriented material. Guidelines for budding authors are available, please send a self-addressed envelope and ask for "How to Write for 80 Microcomputing". 80 Microcomputing is published monthly by 1001001 Inc., a subsidiary of Wayne Green Inc. Entire contents copyright 1982 Wayne Green Inc. No part of this publication may be reprinted, or reproduced by any means, without prior written permission from the publisher. All programs are published for personal use only. All rights reserved.

Cover Photo by Charles Freilberg;
Cover Design and Artwork by
Anne Vadeboncoeur

*TRS-80, Scriptit and TRSDOS are trademarks of Tandy Corp.

4 • 80 Microcomputing, May 1982

Computer Creationists 80

by Jay Rose

When film makers want special sounds, they call on sound and video studios like Jay Rose's. And Jay and other studio technicians look to their micros for help in creating special effects more real than real.



Spiromania 88

by Jake Commander

What do you get when you cross a changing angle with a changing radius? According to Commander 80, computerized psychedelia and some sights to dazzle the eye.

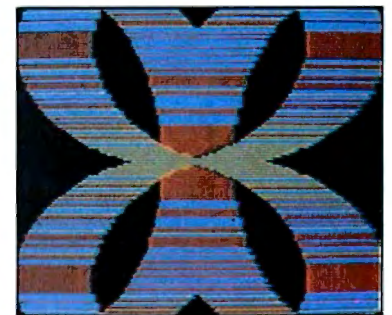

Celluloid CPUs 98

by Michael Nadeau

The use of micros for special effects in motion pictures has been widely publicized, but there are other uses for micros in Tinseltown.

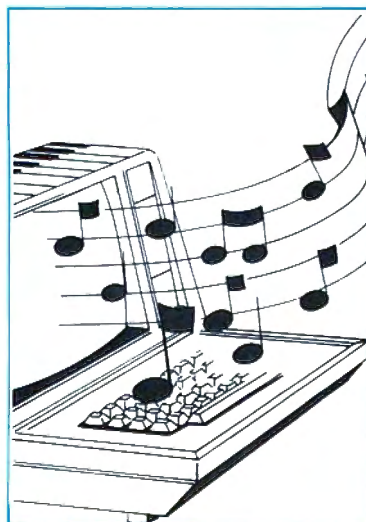

Programmable Sound Generator 106

by Matt Robins

If you have a Model I with disk drives, a synthesizer with nine simultaneous voices can be yours for \$125.

A Little Byte Music 128

by Steve Levine

Are you in the mood to learn how computers got in the GROOVE?

BUSINESS

- 326 **Financial Wizard**
Money Merlin for your Model II. *Charles R. Perelman*

EDUCATION

- 316 **Dynamic Item Scheduling**
Learning by hunches. *L. Benjamin Wyckoff*
- *332 **Time to Make 'em Sweat**
Relax while your 80 does your testing. *Robert L. Hawkes*

GAME

- *292 **Space Chase**
Highballing in the void. *Charles E. Gillen*

GENERAL

- *142 **Programming Pitch**
Your 80 and stereo can make beautiful music together.
Merton L. Davis
- 164 **Fret No More!**
Guitar chords on your 80. *Edward Louis*
- *234 **Micro Melodies**
Teach your 80 to sing. *Kenneth Lee Gibbs*
- 258 **Out of Thin Error**
Not Fair, Odd Disease, Runs Good, et al.
Richard S. Adcock
- *264 **Two Strokes a Side**
Handicapping your golf game. *Michael Avery*
- 272 **Kryha Cipher Machine**
From Union NJ, with love. *C. A. Deavours*
- 280 **Model III Biorhythms**
Unto each rhythm there is a sine wave. *Linda Anderson*
- *298 **Fore! Scorekeeper**
An 80 keeps track of your quest for 80. *Rodger Wells*
- 318 **Computerized Engraving**
With a Model III-pantograph hookup. *Allan S. Joffe*
- 320 **Confessions of a Microholic**
Can't get enough of that silicon wine. *Mike Keller*
- 324 **Damping Cassette Output**
Garbage-in may really be garbage-out. *Ian R. Sinclair*

GRAPHICS

- 104 **Northern Lights**
How a designer's nightmare became a sculptor's dream. *Bert Latamore*
- *242 **A Different Perspective**
The shadow of your CRT. *F. Gilbert Nielsen*
- *282 **Super Banner**
Say it in sign language. *Ron Balewski*

HARDWARE

- 306 **Programmable Baud Rate**
Avoid the homebrewed look. *Hugh Cottle*

HOME/HOBBY

- *238 **Home Budgeteer—Reprise**
Play it again, Pablo. *Manuel Pablo*
- *252 **Computer Racing Form**
Your 80 as tipster. *Ronald H. Bobo*

PERSONALITY

- 176 **Divine Dementia**
Some call it fate, others Kitz-met. *Michael Nadeau*

REVIEW

- 140 **The Philly Phiasco**
Looking for Arthur. *David Gunn*
- 184 **C.Itoh 8510**
All the ingenuity under the rising sun. *Mike Keller*
- 206 **LNW-80**
Build your own. *Richard L. Brocaw*
- 208 **Telewriter**
Cadillac for the Color Computer. *Scott L. Norman*
- 216 **Snappware Eases Random Access**
Eliminate LSET, RSET, MK\$\$ and CVI. *Rick Lederman*
- 218 **ACCEL2 and Microsoft's Basic Compiler**
Parlez-vous machine language? *Dennis Wilkens*
- 224 **The Memory Box**
Add RAM to your I. *Jack Decker*

SERIES

- 228 **Technological Destiny—Part II**
Data hierarchy, computer history and misconceptions.
Gary Dillio

TECHNIQUE

- 302 **I Program Therefore ISAM**
The number-name dichotomy conquered.
Richard S. Adcock
- *322 **Gabby the Space Cowbum**
When the string breaks on your Chatty Cathy...
Richard Ramella

TUTORIAL

- 260 **Model II Primer**
Read this before you run. *Jesse W. Baker*

DEPARTMENTS

- 6 **Remarks** *Wayne Green*
- 10 **Proof Notes**
- 12 **Input**
- 36 **Reviews**
- 62 **80 Accountant** *Michael Tannenbaum*
- 68 **Soft Bits** *Roger Fuller*
- 73 **Commander 80** *Jake Commander*
- 74 **Kitchen Table Software** *David Busch*
- 191 **Letter to Subscribers**
- 336 **News**
- 354 **Reader Service**
- 358 **Reload 80**
- 360 **Medical Opinion** *Philip R. Mills, M.D.*
- 366 **Exclusive Oracle** *Dennis Kitz*
- 370 **Notes from Beneath the Keyboard** *Paul Wiener*
- *382 **Moneydos** *J.M. Keynes*
- 388 **Education 80** *Earl R. Savage*
- 390 **Copernica Mathematica** *Bruce Douglass*
- 400 **Calendar**
- 404 **New Products**
- *on LOAD80 tape

"We Americans have been fed the pap that right wins out in the long run, despite rather vivid proof that the whole idea is hokum."

Why Big Wins

There seems to be some surprise when a new field starts out with a wide range of small firms and eventually ends up with just a few large companies. Those of you who are up on history and oldies still doddering around will remember hundreds of car makes in the early days of automobiles.

What happened was simple. It turns out when you increase production, mathematical principles inexorably apply. The cost of most items decreases 10 to 20 percent every time production doubles. Thus, the more successful a product turns out to be, the lower its manufacturing cost. This success breeds more as the manufacturer is able to reduce prices, gradually forcing other less successful businesses out. We finally end up with one gigantic firm (like General Motors).

What makes one firm more successful than the others, allowing it to kill off the competition? I wish I could smugly convince you that it is generally the excellence of product design. I'm sure that's what any red-blooded American wants to believe. Baloney.

Right here in the microcomputer field we have seen a typical beginning of a new huge industry. Survivors are few, and in no case has technical excellence won the day. Get mad if you will, but the technology of the winners has been almost irrelevant. Oh, it's been good enough, but for every winning computer system the old timers in the field can cite a half dozen better designed products.

Yes, I know that goes against the grain. We Americans have been fed the pap that right wins out in the long run, despite rather vivid proof that the whole idea is hokum. Have you read about the Mafia lately? Just about every member is a millionaire several times over.

In the micro field I've watched dozens of firms grow and then topple. The reasons for their failure are abundantly evident, and their technical prowess (or lack of it) has never been a controlling factor. Most people who've gotten into the micro hardware manufacturing business are pretty sharp technically; their downfalls are

related to their lack of background in business.

An arrogant disdain for software support killed one of the largest firms in the business. Others have gone on to be mere memories on the wings of wasted advertising dollars and ego monuments at computer shows. Would Processor Tech be around today if they avoided exhibiting at NCC and other shows? Cash needed to increase production was blown on monumental show exhibits, peopled with nice chaps who now work for other firms.

The key to business success is knowing what you are doing. The successful entrepreneur knows marketing, advertising, personnel management, salesmanship, financing and business law, and is willing to work 100 hours a week to make it click. It is seldom that such a person ends up anywhere but at the top of the pile.

Big firms are able to bypass the early low cash startup days by spending a lot of money up front to get into massive production, massive advertising, massive marketing. But as the field grows, even large firms can't afford to butt heads. While the pioneer firms in a new field can get started for a few thousand dollars (as we saw with microcomputers just about five years ago) today we are witnessing some giants losing \$10M on sales of \$20M as they misjudge the market. Is it still possible to get in on the ground floor with a few thousand dollars investment? In computers, no. It's getting difficult to make it even with a few million.

The doors are still open for the small entrepreneur turning out peripheral products. It's a bit late to make printers, but the field is wide open for other gadgets.

It is difficult for software publishers to get started today. Two years ago one could get started for a few thousand dollars; now we see firms dumping millions, with only red ink to show. Very small software firms still can eke out a living, but the time is about over when we will see small firms emerging as big ones. Some giants can still come with a few million dollars and buy into the field. In another year or two they will need \$100M—to buy in. Another year or so after that and not even large firms will think it worthwhile.

Each new system marketed is a gold mine for small firms to support. Even the largest firms are unable to provide even a small percentage of the needed support. Witness the growing market for Radio Shack support products advertised in *80 Micro*. Though Radio Shack has tried to keep news of these products from their customers, the word has leaked out and the volume of business seems to be growing for these support firms faster than Radio Shack sales.

The new IBM system is another opportunity for present firms to grow more rapidly and for new firms to get started. Yes, it is still possible to put a few thousand dollars down on the table and walk away with millions.

I recently tried to remember as many names of microcomputer systems as I could. Then I cheated by thumbing through some magazine ads. I had no problem coming up with 76 different firms. If I started counting the individual systems it would go way over 100. Firms are still appearing every month with new computers, but we are seeing as many failures each month as successes. I think we have reached the turning point.

As Radio Shack, Apple, and a few other manufacturers sell larger numbers of systems, their manufacturing costs will go down, allowing them to either cut prices or provide better systems for the same price. This will gradually force the other firms out of business and we will end up with two or three giants.

I was recently a consultant for a firm interested in marketing a computer product to sell for about \$600 at the start. With the expected growth in sales, the retail price would be reduced to around \$150 over a couple of years. Any new firm coming in to compete would have to match the production quantities of this first firm to match costs or take a loss until it could catch up in sales. When sales escalate rapidly, there isn't much of a chance for a new firm, even a large one, to get started in competition.

Look at the shakeout in the mini-computer field in the few short years it's been around—and that product isn't mass-produced on the scale of micros. ■

TAKE A TEST DRIVE.



With a reliable
TRAXX™ 100/200/300
 series add-on
 drive system.

Systems available for Altos, 'Apple,™ Atari,™ Heath,™ North Star,™ S-100, ²TRS-80,
 (Models 1, 11, 111, Color), Zenith.

EAST

CMD Performance
 Windsor, Ct. (203) 688-3862
Digital Data Communications, Inc.
 Richmond, Me. (207) 737-4447

MIDWEST

Cottage Software
 Wichita, Ks. (316) 683-4811
Web Products, Inc. Software Division
 Carol Stream, Il. (312) 653-5229

Meta Technologies
 1-800-321-3552

Insync Systems Corp.
 Alvin, Tx. (713) 331-2024
Central Kansas Computers
 Herrington, Ks. (913) 258-2575
Dataflow Systems
 Indianapolis, In. (317) 888-3640

WEST

Everett Computer Center
 Everett, Wa. (206) 259-0024
Connection 80
 Vancouver, Wa. (206) 573-0319
H & S Microsystems
 Burnaby, BC Canada (604) 430-4145

TRAXX

COMPUTER CORPORATION

Dealer Inquiries — 1-800-621-3102, (312) 987-1024



¹Apple is a registered trademark of Apple Computer, Inc.
 ²TRS-80 is a registered trademark of Radio Shack — a Tandy Company.

INTELLIGENT PRINTER INTERFACE

Free Your Computer from the
Mundane Task of Printing



Imagine being able to use your computer seconds after beginning an extensive printout.

Visualize your printout with page breaks, page numbering and titles, margins of your choice, indented carryover lines, on any size paper!

Appreciate the time and money you will save by not waiting for your printer.

SooperSpooler, a buffered printer interface, maintains control over your printer while you go on using your computer for more productive activities. Eliminate waiting while your printer pecks through a long document. SooperSpooler accepts information from your computer at up to 3000 characters per second and feeds it to your printer as fast as it can handle it—without using any of your computer's memory or time!

SooperSpooler features include:

- 16K Memory (62K optional)
- Buffer Status Readout
- Space Compression
- Pagination
- Single Sheets
- Headers and Page Numbering
- Indentation on Carryover Lines
- Self Test Routine
- Features also Software Controllable
- Plugs into Model I, II, III systems
- ★ 16K Parallel I/O Unit—\$349.00!
- ★ Serial I/O Option—\$95.00
- ★ 46K Memory Option—\$159.00

SooperSpooler™ by Compulink—
The missing link that gives your
microcomputer mainframe printing.

COMPULINK CORPORATION

✓ 276

1840 Industrial Circle
Longmont, CO 80501 (303) 651-2014

Send for brochure
Dealer inquiries welcome
Call for information: 800-525-6705

80 REMARKS

Budding Apples

Experts in the field agree that Apple sales have passed Radio Shack by in the last year. I suspect this is due to two main causes: better support from satellite firms and better advertising strategy.

The average Radio Shack computer customer, unaware of *80 Micro*, is also unaware of 99 percent of the support for the TRS-80 systems. All he can see is the few peripherals and programs on display at the local Radio Shack store. This *hurts* sales. Apple was able to come from about 1/2 of Radio Shack sales to beat them with in little more than a year.

If this pattern continues, Apple will be able to undercut Radio Shack on prices, accelerating the disaster. Apple also has an advantage in their overseas sales.

A recent report on microcomputer sales in Italy is unfortunately rather typical. Commodore started out the best-seller there a couple years ago, but by the end of this year Apple is expected to pass them by, with TRS-80 sales projected to be about 16 percent of Apple sales. I've seen a similar pattern in many of the countries I've visited in the last few years.

Can Tandy turn the tables on this debacle and regain their leadership in the U.S.? Yes, they can, but I'm not convinced they will. Tradition may run too deep for the needed changes.

It's too soon to see how Apple will respond to IBM's invasion of the micro field. Will IBM be as hospitable to supporting firms as Apple or as hostile as Radio Shack? I suspect Apple's real strength is in the combined push of the parent firm and all the small firms making Apple products. *This* has defeated Tandy in sales.

Remember, when entrepreneurs start new firms, or when medium-sized firms cook up new products, they understand that a larger customer base means an easier sale. Thus the emergence of Apple in front will reinforce its strength by encouraging development and production of even more supporting products. Freelance programmers write programs for the largest selling system; they make more money that way. This, too, will work against Tandy.

One other factor: The difficulty of reaching the Radio Shack customer to sell supporting products is made agonizing by Radio Shack's desire to be the *only* supplier for their customers. *80 Micro* is a good means of selling to this market, but it probably reaches only half of the Radio Shack customers. It is far easier to reach the Apple customer with advertising.

Radio Shack products have to be sold

through largely hostile computer stores or else by mail order. Apple equipment and programs can be sold through extremely friendly Apple dealers.

We know IBM is going to be around. Their entry has been successful just on the power of their reputation. Their system is well designed and their marketing fine. If IBM continues to do things right, it could come out on top.

Apple, despite the Apple III debacle last year, is a strong company. Their marketing program is hard to beat, and their ads are eye-catching and visible.

With the largest customer base in this country, Radio Shack is by no means out of the picture. They must do some serious customer research and improve their image. Why not come to grips with the TRS-80 support industry and encourage it instead of fighting it?

If we could get *80 Micro* into the company-owned stores (which is most of them) it would enhance equipment sales. We are selling through a growing number of independent Radio Shack stores and the owners are most enthusiastic about the results. The factory-owned stores need a few hundred more programs, something Radio Shack has so far not been able to provide. I don't think even a 100,000 square foot plant filled with programmers can do the job of 10,000 freelance programmers. ■

Coco

That's what a lot of the readers called the Color Computer in their letters of anguish over my editorial on the lack of support for this system.

A letter from Jon Shirley assures us that Coco will continue to be produced for the next year at least. That's most reassuring, for I did not invent the rumors of it being dropped. Radio Shack's lack of candor discourages the press from even asking them about plans. They are often secretive to the point of emulating the CIA on matters of new products or dropping old ones, so only by bringing rumors into the open can answers be gotten.

On the bright side, many readers agree with the staff here at *80 Micro* that Coco is a vastly underrated system. Indeed, it appears even the folk at Tandy are not really aware of the power of the system. Many readers have promised articles and others have already started sending in programs. Perhaps I primed the pump. I assure you that any lack of support for Coco reflects the lack of input, not our lack of enthusiasm. ■



META TECHNOLOGIES

26111 Brush Avenue, Euclid Ohio 44132
CALL TOLL FREE 1-800-321-3552 TO ORDER
IN OHIO, call (216) 289-7500 (COLLECT)



EPSON MX-80, MX-80FT, MX-100 PRINTERS

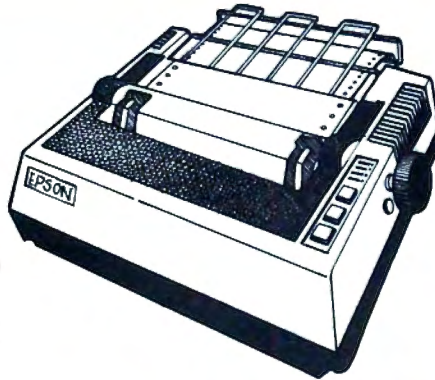

NEW LOWER PRICES!

CABLES, INTERFACES, ETC.

TRS-80 KEYBOARD INTER-
FACE & CABLE \$69.95

APPLE INTERFACE
& CABLE \$99.95

IEEE-488 (PET) INTERFACE
& CABLE \$79.95

SERIAL (RS-232)
INTERFACE \$74.95

GRAFTRAX OPTION
(MX-80 & MX-80/FT) .. \$34.95

EXTRA-LONG 10 ft. RIBBON

CABLE \$24⁹⁵

CONNECTS EPSON PRINTER
& TRS-80 MICROCOMPUTER

WE SERVICE WHAT WE SELL!

complete DISK DRIVES

Includes Case, Power Supply
and External Drive Connector

from **\$289⁹⁵**

WE ALSO SELL THE
INCOMPARABLE



ADD-ON DISK DRIVES

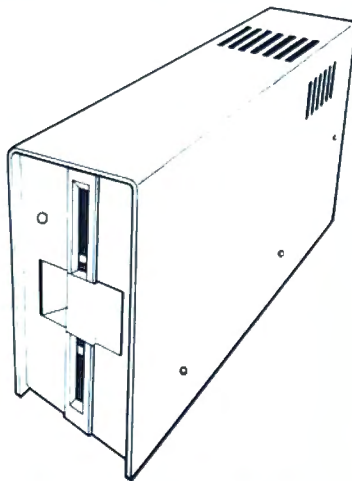

FULL ONE-YEAR LIMITED WARRANTY

(Parts and Labor, write for complete details)

TRAXX Add-On Disk Drives are Individually Tested, Burned In, Ready to Plug In and Run, and Include Technical Documentation and a Static-Free Dust Cover.

CALL FOR PRICE

PARAGON

magnetics™
Gold DISKETTES

MTC's

premium Single-Sided, Soft-Sector'd
DOUBLE-DENSITY, 5¼-inch diskettes with
reinforcing HUB-RINGS. Individually 100%
ERROR-FREE certified. Invest in GOLD!

PARAGON MAGNETICS GOLD \$23.95

Scotch®

Soft-Sector'd Diskettes

5-1/4" 1S/Dden (744-0)	\$28.95
5-1/4" 1S/DDden (744D-0)	\$31.95
5-1/4" 2S/DDden (745-0)	\$39.95
8" 1S/Dden (740-0)	\$29.95
8" 1S/DDden (741-0)	\$37.95
8" 2S/DDden (743-0)	\$49.95

Hard-Sector'd Diskettes

5-1/4" 1S/Dden 10-sector (744-10)	\$28.95
5-1/4" 1S/DDden 10-sector (744D-10)	\$32.95
5-1/4" 2S/DDden 10-sector (745-10)	\$39.95
5-1/4" 1S/Dden 16-sector (744-16)	\$28.95
5-1/4" 1S/DDden 16-sector (744D-16)	\$32.95
5-1/4" 2S/DDden 16-sector (745-16)	\$39.95
8" 1S/Dden 32-sector (740-32)	\$33.95
8" 1S/DDden 32-sector (741-32)	\$39.95
8" 2S/DDden 32-sector (743-32)	\$49.95

Supplies

5-1/4" Head cleaning kit	\$29.95
8" Head cleaning kit	\$29.95

Authorized Distributor
Information Processing Products



VERBATIM

Soft-Sector'd Diskettes

5-1/4" 1S/DDden (MD525-01)	\$26.95
5-1/4" 2S/DDden (MD550-01)	\$39.95
5-1/4" 2S/4Den (MD557-01)	\$51.50
8" 1S/DDden (FD34-8000)	\$43.95

Hard-Sector'd Diskettes

5-1/4" 1S/DDden 10-sector (MD525-10)	\$26.95
5-1/4" 2S/DDden 10-sector (MD550-10)	\$39.95
5-1/4" 2S/4Den 10-sector (MD557-10)	\$51.50

'RINGS' & THINGS

HUB RING KIT for 5¼" disks	\$10.95
HUB RING KIT for 8" disks	\$12.95
REFILLS (50 Hub Rings)	\$ 5.95
CLEANING KIT for 5¼" drives	\$24.95
5¼-inch diskette case	\$3.50
8-inch diskette case	\$3.95
5¼-inch File Box for 50 diskettes	\$24.95
8-inch File Box for 50 diskettes	\$29.95

TRS-80 is a trademark of the
Radio Shack Division of Tandy
Corporation. DATALIFE is a
trademark of VERBATIM PLAIN
JANE, PARAGON MAGNETICS.
are trademarks of MTC.

© 1982 by Meta Technologies
Corporation

MOST ORDERS
SHIPPED WITHIN
ONE BUSINESS DAY

24 Hr. Bulletin Board
(216)289-8689

PRICES IN EFFECT
THRU
May 31, 1982

Prices, Specifications,
and Offerings subject to
change without notice
8205

WE ACCEPT

- VISA
- MASTER CHARGE
- CHECKS
- MONEY ORDERS
- C.O.D

- Add \$3.00 for shipping
& handling
- \$3.00 EXTRA for C.O.D.
- Ohio residents add 6.5%
sales tax.

Proof Notes

the editors look at the issues

MANAGING EDITOR
Debra Marshall

SENIOR EDITOR
Pamela Petrakos

NEWS EDITOR
John P. Mello Jr.

REVIEW EDITOR
Michael Nadeau

NEW PRODUCTS EDITOR
Janet Fiderio

EDITORS
Lynn Rognsvoog, Carolyn Nolan,
Steven Frann, Kerry Leichtman

TECHNICAL CONSULTANT
Jake Commander

TECHNICAL EDITORS
Dennis Kitsz: Contributing Editor;
G. Michael Vose: Features, Editor;
Art Huston: Editor

PRODUCTION EDITOR
Susan Gross

LAYOUT EDITORS
Joan Ahern, Bob Dukette, Sue Hays,
Anne Vadeboncoeur

PROOFREADERS
Peter Bjornsen, Caron Taylor, Patrice
Laughner, Louis Marini

EDITORIAL ADMINISTRATION
Pat Graham
Nancy Noyd

Subscriptions:

Problems with Subscriptions: Send a description of the problem and your current and/or most recent address to: *80 Microcomputing*, Subscription Department, PO Box 981, Farmingdale, NY 11737.

Change of Address: Send old label or copy of old address and new address to *80 Microcomputing*, PO Box 981, Farmingdale, NY 11737. Please give eight weeks advance notice.

Microfilm: This publication is available in microform from University Microfilms International. United States address; 300 North Zeeb Road, Dept. P.R., Ann Arbor, MI 48106. Foreign address; 18 Bedford Row, Dept. P.R., London, WC1R4EJ, England.

Dealers: Contact Ginny Boudrieau, Bulk Sales Manager, *80 Microcomputing*, Pine St., Peterborough, NH 03458. (800) 258-5473.

Although some may be hesitant to accept the computer's contribution to the hallowed and sometimes dusty halls of art history, these electronic gadgets are making a contribution. It should come as no surprise, as there has always been a faction in the artistic community who have been anxious to utilize the latest technological advancement, and the computer has become the latest toy.

This issue reflects the applications and attitudes of various members of the artistic community towards computers. Sculptor Rob Fisher is an example of one artist who prefers chrome and computer-aided design (CAD/CAM) to clay and a palette knife, while commercial producer Jay Rose highlights how microcomputers, including the Model I, have freed him from much time-consuming drudgery leaving more time to be more creative. Film-makers are using micros to synchronize complicated special effects and to

be taught by a Model II?)

Computers are affecting the arts indirectly as well. Many non-profit organizations now rely on computerized fund development and management systems, greatly increasing their funding. And many writers now use word processors.

Our conception of art will always mean different things in different times and places. Like the times, it is always changing, as are the media and tools which are used to create it. In the hands of an artist the microcomputer simply becomes such a tool. This machine, which ordinarily is used to process little bits and bytes of information in the most efficient manner, is now being used to create spectacular graphics or music. Jake Commander has a few words to say about this:

"But is it really art? Oh please, can I be the last person to ask that hackneyed question?"

"Does storytelling lose any of its artistic value because it was written using a word processor?"

keep track of a film's almost unmanageable budget. And our own Jake Commander has, with the Color Computer, created some truly beautiful and unexpected graphics reminiscent of stained glass windows and oriental rugs.

Musical applications of the TRS-80 are featured, including a hardware tutorial which tells you, for \$150 in parts, how you can create your own synthesizer. You can even teach yourself to play the guitar with the Model I, an interesting twist of a computer application. (Will our next Bob Dylan

"Of course it's art. At least if you want it to be. Art is created from the minds of artists and becomes real when tools are used to produce an aesthetically interesting end result. Notice I say the word interesting as opposed to pleasing. Beauty, as it is often said, is in the eye of the beholder. However, just because you don't like it doesn't stop it being art.

"Notice also that the tools used vary according to the art form and the individual

Continued on page 66

Dennis Kitsz has had a second attack of California sun blindness. He left for the west leaving us with only the tail-end of his "Applications" column. We considered publishing it as is, but decided not to let him off the hook that easily. Send your complaints to Dennis in Roxbury, VT. If Dennis survives CA without joining some sunny, trendy cult, he will be back with "Applications" and some far-fetched tale next month.

The left bracket, [, replaces the up arrow used by Radio Shack to indicate exponentiation on our printouts. When entering programs published in *80 Microcomputing*, you should make this change.

80 formats its program listings to run 64-characters wide, the way they look on your video screen. This accounts for the occasional wrap-around you will notice in our program listings. Don't let it throw you, particularly when entering assembly listings.



META TECHNOLOGIES



26111 Brush Avenue, Euclid Ohio 44132
CALL TOLL FREE 1-800-321-3552 TO ORDER
IN OHIO, call (216) 289-7500 (COLLECT)

MTC AIDS-III™

MODELS I & III ...\$69.95 MODEL II ...\$99.95

Introducing the latest addition to MTC's family of data management systems, AIDS-III. NO PROGRAMMING, easy to use. COMPLETE PACKAGE including demonstration application, documentation and MAPS-III (see below).

- Up to 20 USER-DEFINED FIELDS of either numeric- or character-type.
- CHARACTER-type fields may be any length (total: up to 254 characters).
- NUMERIC-type fields feature automatic formatting, rounding, decimal alignment and validation.
- Full feature EDITING when adding or changing records:
 - ENTER FIELD (can't type-in more characters than specified).
 - BACKSPACE (delete last character typed).
 - DELETE FIELD contents.
 - RESTORE FIELD contents.
 - RIGHT-JUSTIFY FIELD contents.
 - SKIP FIELD (to next or previous field).
 - SKIP RECORD (to next or previous record).
- SORTING of records is MACHINE CODE assisted.
 - 200 RECORDS (40 characters) in about 5 SECONDS.
 - ANY COMBINATION of fields (including numerics) with each field in ascending or descending order.
- SELECTION of records for Loading, Updating, Deleting, Printing and Saving is MACHINE CODE assisted.
 - Specify up to 4 CRITERIA, each using one of 6 RELATIONAL COMPARISONS.
 - LOAD or SAVE selected records using MULTIPLE FILES.
 - Example: Select records representing those people who live in the state of Colorado, but not in the city of Denver, whose last names begin with "F" and whose incomes exceed \$9000.00.
 - Example: Select records representing those sales made to XYZ COMPANY that exceed \$25.00, between the dates 03/15 and 04/10.

MAPS-III (MTC AIDS PRINT SUBSYSTEM), included at no charge, has the following features:

- Full AIDS-III SELECTION capabilities.
- Prints user-specified fields DOWN THE PAGE.
- Prints user-specified fields in titled, columnar REPORT FORMAT, automatically generating column headings, paging and (optionally) indentation.
- Can create a single report from MULTIPLE FILES.
- Prints user-defined formats for CUSTOM LABELS, custom forms, etc.

BELOW ARE TESTIMONIALS from owners of AIDS systems. These are absolutely authentic statements and are typical of the comments we receive.

"This program will do more for my business than all the other programs I have, combined."

David Wareham, Vice President (EDP), National Hospital and Health Care Services Inc.

"We have 32 different Data Base Management packages for the TRS-80. AIDS-III is easily the best. It also makes it easier for us to step up to our Model II since the package is available for both computers."

Jack Bilinski, President, 80 Microcomputer Services

"Your AIDS program is far and away the finest information management system that I've ever seen. I am currently using it to maintain a clear picture of the demographic data on all the kids in our residential treatment program and it is working for me superbly."

Frank Boehm, Director, Front Door Residential Treatment Program

MTC CALCS - III™

Models I & III\$24.95
Model II\$39.95

MTC's most popular AIDS subsystem. Use for report generation involving basic manipulation of numeric data. Features are:

- Columnar Headings
- Optional Indentation
- User-specified Columnar Totals
- Columnar values computed using constants and/or column values
- Balance forward calculations
- Use for accounting, inventory, financial and other numeric-based systems. in

EPSON PRINTERS

DISK DRIVES

DISKETTES

BOOKS and more!!

AIDS OWNERS! WE HAVE WHAT YOU'VE BEEN WAITING IV. . .

- MTC CALCS-IV™, that is.
- More Computations
 - Save Report Formats on Disk
 - Faster, and more!

MTC CALCS-IV™ \$39.95
For Models I & III \$39.95
For Model II \$59.95

MTC AIDS MERGE-III™

This subsystem will combine up to 14 AIDS-created data files into a single, large file. An optional purge capability removes duplicate entries while performing the merge operation (can even be used to eliminate duplicates in a single file). Machine-code assisted for high-speed performance. MERGE-III™ properly handles files sorted by any combination of fields, including numerics, with each field in ascending or descending order.

MTC AIDS MERGE-III™ \$19.95
For Models I & III \$19.95
For Model II \$29.95

THE COMPLETE MTC AIDS-III™ PACKAGE

SAVE \$\$\$\$

Includes MTC AIDS-III™
CALCS-III™ and MERGE-III™

*A comprehensive system
at a competitive price!*

MODEL I & III \$99.95
MODEL II \$149.95

Add \$25 for CALCS-IV™

AIDS/P™ IS ALMOST HERE!

TRS-80 is a trademark of the Radio Shack Division of Tandy Corporation. DATALIFE is a trademark of VERBATIM. PLAIN JANE, AIDS-I, AIDS-III, CALCS-III, CALCS-IV, MERGE-III are trademarks of MTC.
© 1982 by Meta Technologies Corporation

**MOST ORDERS
SHIPPED WITHIN
ONE BUSINESS DAY**

24 Hr. Bulletin Board
(216) 289-8689

**PRICES IN EFFECT
THRU
May 31, 1982**
Prices, Specifications,
and Offerings subject to
change without notice.
8205

WE ACCEPT
• VISA
• MASTER CHARGE
• CHECKS
• MONEY ORDERS
• C.O.D.

• Add \$3.00 for shipping & handling
• \$3.00 EXTRA for C.O.D.
• Ohio residents add 6.5% sales tax.

“Unlocked software is good for business, our business, your business and the customer’s business.”

Off Track on Pirates

In the old days sailing ships had problems with pirates. Two great nations used opposite solutions to reduce the piracy. Spain increased the cannon and armor on its ships. This increased the weight, cost and slowed down the vessels making them less desirable as a shipping vehicle. England did the opposite. It lightly armed its small, inexpensive ships, making them faster. They were better at their intended purpose—to trade and deliver cargo quickly. History has shown us that England won, not because they avoided pirates better than Spain, but because they did not let pirates get in the way of good business, in this case, efficient shipping.

This bit of historical fact has great import in the software piracy problem of today. Many companies are spending too much time and money worrying about pi-

“Reformed pirates (privateers) make the best dealers.”

rates. They reduce, if not ruin their products’ usability with locked disks, unlistable programs, secret source code, hidden locks, codes in ROM chips, full page ads devoted to pirates (e.g. Atari), and so on. These devices have made many programs inefficient, costly to produce and support. The buyer is taxed greatly for he cannot make modifications or backup copies. Often he is inconvenienced by added expenses for backups or future modifications. This hurts sales and angers good customers.

There is a better way as exemplified by our company, Andent Inc. We produce Apple II software for health professionals (medical/dental systems, appointments, hypnosis, and so on). We have been in business since 1978, which makes us one of the oldest software houses for microcomputers. We are making a profit . . . and always have. We pay our bills and pro-

grammers on time. All our software is unlocked and can be copied for back-up purposes. We support all sales offering free replacement of damaged disks. The user can list and modify all our software. There is internal as well as written documentation.

We do business this way because it pays. It pays us, and it pays our customers for buying our software. Because our software is unlocked, there is little to no problem with: backups (our customers make their own); updates (we mail out a letter with changes); phone calls (documentation and listings tell you how to make modifications); changes in operating systems; hard disk compatibility; slot compatibility; printer slot and special character problems; disk recalls; equipment incompatibility; and low cost of programming and debugging.

The business community, our customers, like this. They are buying a program, not a software lease. They have immediate support since changes and problems can be made over the phone or by letter. They can backup immediately and for as many times as needed. They like our low prices. Unlocked software is *good for business*, our business, your business and the customer’s business.

But what about pirates? Large scale pirates, those enterprising souls who copy our programs and sell them world-wide, are discovered and given an option to become our dealers and pay us a royalty on distributed software (or meet us in court). As in the old sailing days, reformed pirates (privateers) make the *best* dealers and we do not mind sharing the wealth. For those who do not want to cooperate, we go back in history for the remedy. The English and Spanish both learned that a few executions were good for the morale of the troops. Small time pirates (give it to your friends) can be controlled by low program cost, registration, continuing updates and documentation. It just does not pay to get our programs second hand.

Andent Inc. believes a sale of software is just that—the sale of programs, listings, source code, backup capability . . . a complete sale. Our customers do not buy a disguised lease—they buy and own our

products. We do this because locking programs is very expensive, time-consuming and hurts sales.

It is time the industry realizes our prime business is producing and distributing a product, not fighting pirates.

*E.J. Nelburger, President
Andent Inc.
Waukegan, IL*

Is the TRS-80 the only choice?

Earl Savage’s Education 80 column (*80 Microcomputing*, January 1982) raised my temper enough to cause me to sit at my keyboard and pound out a reply.

Micros indeed have a major role in education and that role will unquestionably grow in the next few years. But so has the minicomputer. The real strength lies in the combination of both systems. A school that bases its teaching on micros alone will soon have some real problems. Any meaningful education application requires mass storage for programs and data files. The total micro shop will have an impossible job in cataloging, copying and other file maintenance chores to say nothing of the costs of buying media for every system. What about the maintenance of all those tape recorders or disks? How can you ensure students will work on the right lesson and get their results recorded on the right file?

A minicomputer acting as a file server for a network of microcomputer terminals offers the best of both worlds. The student has a micro for simple programs, and he can use the host for more advanced work. Software development is much easier on a mini with sophisticated editors, file systems, and author languages.

In the January column, Mr. Savage reviews the options to prove the TRS-80 is the only acceptable choice but he makes an interesting contradiction. He dismisses the Model I, II, and III’s lack of color by noting “. . . color circuitry which produces a pretty display but adds absolutely nothing of value to 99 percent of



META TECHNOLOGIES

26111 Brush Avenue, Euclid Ohio 44132

CALL TOLL FREE 1-800-321-3552 TO ORDER
IN OHIO, call (216) 289-7500 (COLLECT)



1001 THINGS TO DO WITH YOUR PERSONAL COMPUTER

BY MARK SAWUSCH

333 pages \$10.95

333 pages, written in simple terms, of "what-to-do" and "how-to-do-it". Suitable not only for microcomputers, but for programmable calculators as well. Includes program listings, formulas, a glossary of computer terms and more! Definitely a MUST BUY!

"TRS-80™ DISK AND OTHER MYSTERIES"

by Harvard C. Pennington

132 pages written in PLAIN ENGLISH packed with HOW TO information with details, examples and in-depth explanations. Recover lost files and directories, remove file protection, make BASIC programs unlistable. How to use SUPERZAP, recover from DOS errors and MORE!

TRS-80™ DISK \$19.95

"OTHER MYSTERIES" VOLUME II

by James Farvour

"MICROSOFT™ BASIC DECODED & OTHER MYSTERIES for the TRS-80™" is a primer for the internal workings of cassette and disk BASIC. More than 300 pages of explanations, examples and comments about the Level II ROM.

MICROSOFT™ BASIC DECODED \$24.95

"OTHER MYSTERIES" VOLUME III

by Dennis Kitsz

More than 300 pages of practical hardware and software modifications and projects. Discover the mysteries of "THE CUSTOM TRS-80™"!

THE CUSTOM TRS-80™ \$28.95

"OTHER MYSTERIES" VOLUME IV

BASIC FASTER AND BETTER

Time-tested and proven techniques and routines that can be used in hundreds of ways to make your programs smaller, faster and better.

BASIC FASTER & BETTER \$24.95

BFBLIB subroutines diskette \$19.95

BFBDEM demonstration diskette \$19.95

MICRO SYSTEMS SOFTWARE'S DOSPLUS 3.4

Fast. Smooth. Easy. Maximum features and powerful options:

- Multi-key, multi-array BASIC sort
- Controlled screen entry (INPUT @)
- TOTAL device routing supported in DOS and BASIC
- Last DOS command is repeatable
- DISKDUMP utility and more!
- Tape-to-Disk/Disk-to-Tape utility
- More reliable, much improved BACKUP
- Can read 40-track disks in 80-track drives
- 200+ page user's guide (includes technical reference section)

Specify MODEL I or MODEL III \$149.95

APPARAT'S NEWDOS/80 Version 2.0

INCLUDES MTC QUE CARD™

Enhanced version of NEWDOS/80 featuring:

- Model I double density support
- Directory size is tripled
- Dynamic merge of BASIC programs
- Peripheral handling routing
- Enhanced DISASSEMBLER
- Includes SUPERZAP and more!
- Enhanced Model I/Model III compatability
- Selective clearing of variables
- Page by page listings of BASIC programs
- Command chaining

Specify MODEL I or MODEL III \$149.00

Michael Shroyer's ELECTRIC PENCIL VERSION II

for Model I and Model III

An expanded version of the critically acclaimed original word processing system! Includes all features of Version I plus many new extensions. Runs under most disk operating systems, has improved video text handling, loads any ASCII file for editing (including BASIC files), single sheet mode for printing on letterhead and more! Simple to use, features 2-key commands. An incredible package at an incredible price!

SPECIFY MODEL I OR III

Disk Version \$79.95

Tape Version \$69.95

CALL FOR AVAILABILITY

Let your TRS-80™ Test Itself With THE FLOPPY DOCTOR & MEMORY DIAGNOSTIC

by David Stambaugh

A complete checkup for your MODEL I or MODEL III. THE FLOPPY DOCTOR-Version 3 completely checks every sector of single or double density 35-, 40-, 77-, or 80-track disk drives. Tests motor speed, head positioning, controller functions, status bits and provides complete error logging. THE MEMORY DIAGNOSTIC checks for proper write/read, refresh, executability and exclusivity of all address locations. Includes both diagnostics and complete instruction manual.

SYSTEM DIAGNOSTICS . \$24.95

For MODEL III \$29.95

MORE PRODUCTS

TRS-80 is a trademark of the Radio Shack Division of Tandy Corporation. DATALIFE is a trademark of VERBATIM. PLAIN JANE, AIDS-I, AIDS-III, CALCS-III, CALCS-IV, MERGE-III are trademarks of MTC
© 1982 by Meta Technologies Corporation

MOST ORDERS SHIPPED WITHIN ONE BUSINESS DAY

24 Hr. Bulletin Board (216)289-8689

PRICES IN EFFECT THRU May 31, 1982
Prices, Specifications, and Offerings subject to change without notice.
8205

WE ACCEPT
• VISA
• MASTER CHARGE
• CHECKS
• MONEY ORDERS
• C.O.D.

• Add \$3.00 for shipping & handling
• \$3.00 EXTRA for C.O.D.
• Ohio residents add 6.5% sales tax.

its educational and business uses." Then, with the emphasis of a boxed headline notes "the real world is full of sounds so why should programs be silent?" Well, the real world is also full of color so why should programs be monochrome? When was the last time you saw a textbook, particularly one for elementary grades, without color? Color can add significantly to educational programs by providing more attractive displays and highlighting certain statements or portions of graphics.

Ron Ginger
Framingham, MA

Finances Rule

Mr. Ginger raises several interesting points. In some respects, education does (or should) operate like a business but in many ways it is completely different. Public educational agencies operate (if one may use that word loosely) like a business that is perpetually on the verge of bankruptcy. Educators cannot raise the margin of profit slightly to bring in a few

"Educators cannot raise the margin of profit slightly to bring in a few more dollars."

more dollars and they cannot purchase raw materials more cheaply. They continually fight for operational necessities. If you doubt this, ask any teacher, administrator, board member or even custodian.

In education, you develop a means to get the most for every dollar spent—not just in fairness to the taxpayer but because the ratio of dollars to needs is so low. After a few years, you forget that the whole world does not operate the same way. Therefore, I beg to be forgiven for not stating that which is obvious to those of us in the field.

Mr. Ginger may be surprised to learn that I would like nothing better than a network consisting of a minicomputer and two or three (or more) dozen microcomputers. That kind of setup simply is not in the cards for 99.9 percent of the public schools in this country. Choices must be made.

My choice, and the choice of the great majority of educators with whom I have

communicated, would be to have eight or ten micros and dozens of programs rather than one micro, one mini and perhaps one program for the mini. (The use of "would be" is deliberate because most of us are struggling to get a half-dozen micros.) My computer prices may be somewhat off—I stopped pricing them a few years ago when the capacity of the micros became great enough to do the job—but you get the idea. (Have you priced a mini program lately? How many teachers or students do you suppose are able to program a mini?)

I believe Mr. Ginger underestimates the power of a micro in the hands of a competent programmer. Is he aware that programs may be merged? That variables may be passed from program to program? That programs can be chained? These and other techniques can be used, if necessary, to overcome the shortcomings he sees in the micro. Why, one little Model III disk can hold enough programs and data to keep him busy for months!

Just a couple of key punches and my Model III has a very sophisticated editor; the file system will do far more than I have had need for in educational or business programming to date; authoring programs

as well as other authoring languages are just a punch away. If the Model III does not have enough power or storage space, there is the Model II, and, of course, the Model 16 (Is that a micro or a mini?). The long and short of it is that you learn to make do with what you have and the Model III will do plenty.

With regard to color and sound, Mr. Ginger again misses the point. You can add sound to a TRS-80 for \$10 or less, so why not use it—even school budgets can produce an occasional \$10. Color, on the other hand, costs a bundle. There is the additional cost of the micro itself (or a trade-off in more limited features), and the extra cost of a color monitor is significant. My personal feeling is that the additional cost is not justifiable unless color is an intrinsic part of the topic at hand.

I would like to take this opportunity to welcome the reader to the real world of educational finances. Now, would you like to increase their taxes so that their schools will not have to make such

choices... but didn't I hear that the citizens of Massachusetts recently decided to do just the opposite?

Earl R. Savage
Colonial Beach, VA

Video Screen Dump

I noticed in the February 1982 Input/Output column that R.S. from Madison, WI was interested in printing his chess board to send through the mail. I do not play chess so subsequently I know nothing of the software program he is using. However, I have developed a small program (see Program Listing 1) that may

```
10000 FOR I=15360 TO 16383 STEP 64
10010 FOR II=8 TO 63
10020 LPRINT CHR$(PEEK(I+II));
10030 NEXT II
10040 LPRINT " "
10050 NEXT I
10060 RETURN
```

Program Listing 1

solve his problem if the chess game software is in Basic. The code prints an exact duplicate of the video screen when called as a subroutine from the Basic program. It prints all alphanumerics and graphics.

If you want to place a left margin indentation, add a line between 10000 and 10010 to LPRINT STRING\$(SP%, 32);. SP% determines the indentation and can be changed by the operator.

I have used this little subroutine many times and have had no problem with it. R.S.'s only problem will be to find the location in the chess software to call the subroutine.

Gerald E. Ives
East Syracuse, NY

Burn the Brat

I would like to take my TRS-80 down to the middle of Portland and burn it, but I don't have the money to replace it.

I did not purchase my Model III from Radio Shack, and it has TEAC drives instead of the Radio Shack standard. Also, it is hooked up to a reconditioned IBM Selectric typewriter. All of this was fine with me, until my troubles began.

First was the autocratic printer control. I could not get the brat to follow the Script format commands. For four months I went around in circles between the dealer, the man who adapted the Selectric, and

Radio Shack. No one knew anything. Finally, one of the Radio Shack people carelessly dropped a remark about forms, and that slim clue led me to the DOSPLUS Forms command, and now I can print. The TRSDOS Forms command is insufficient to do the job.

The modem I purchased works fine, but after I bought it, I discovered that I could not use it without a program. Then I discovered I could not talk to the brat in its own language without an editor/assembler, and only Radio Shack knows whatall. I was beginning to feel that I had bought a car that would steer only to the right.

And that blessed Scripsit. It works well, as far as it goes. But, it will not cooperate with either of two Dvorak keyboard programs. The end-of-file marker is not the same as that used by the operating system programs, so I have been unable to use its editing facilities on other programs, such as Fortran, or Basic. And the silly Scrimp reboots every time I need to read the directory, which means resetting the forms each time.

prove its manners. My last visit to Radio Shack, an attempt to get the Scrimp onto a DOSPLUS disk, met not only with refusal, but with demands of "Where did you get this?", "Do you have your receipt?"; with remarks about my DOSPLUS disk and attempts to uncover other nefarious schemes by peeling off my label to see what was under it; by checking the Scrimp disk to see if I was lying and had backed it up. The final affront was to suggest that I bring in my brat and have its drives operated on.

Well, Radio Shack, you don't need to worry about my TEAC drives any more. Not only will the brat never come within scalpel distance, but neither will I, for any reason. For information I will go to the magazines and the users groups, and those who pry into inner workings and put nasty little patches on things; for repairs, to a member of the users group; and for wares of whatever kind, to anywhere but Radio Shack.

Dorothy R. Mooney
Tigard, OR

**"I will not
tolerate Radio
Shack's attitude."**

Thinking I could improve things, I foolishly went and bought the Model III update for Scripsit and I can't use the thing at all. New programs will run for me, if I first convert them — that is, copy them onto my command disk. Scripsit is protected so well that I cannot access it, cannot run the disk in drive 0, cannot back it up, and can use it at all, only in drive 1. I'm not a juggler. Then, improving on its previous efforts, the Scrimp even saved a Basic program on top of a Fortran program.

The problems in themselves I can tolerate. The information curtain I cannot. And Radio Shack's attitude I will not.

Since solving the printing problem, I have discovered (Thank you, 80 Micro-computing) that it is well known. I feel that both the man who adapted the Selectric and Radio Shack should have been able and willing to give me the answer right away. Since Radio Shack sells its products to beginners, the need for special programs should be made clear before purchase. Most importantly, and the point of this diatribe, Radio Shack should im-

Radio Shack Replies

Wayne Green actively pushes sales of various non-Radio Shack items. Fine, but the customer must know what he or she is doing and be prepared accordingly. The term is caveat emptor.

Let's look at what Ms. Mooney has and what her problems are (as best that I can sort out from her letter).

She has a TRS-80 Model III, purchased from a non-Radio Shack source; non-Radio Shack disk drives; IBM Selectric typewriter for a printer; non-TRSDOS operating system; and a modem (model unspecified and unimportant).

She has experienced the following problems: Format commands from Scripsit are not handled properly; utilization of a modem requires some software; programming in machine language requires an editor/assembler; Scripsit will not work with either of two Dvorak keyboard programs she has; and Scripsit will not run in drive 0, cannot be backed up or accessed in any way and will only run in drive 1.

I suspect the need for machine language programming stemmed from the inability of Scripsit to send proper commands to the IBM Selectric. There have been a number of articles in several magazines about Selectrics and that could be considered "general knowledge" but we do not have the capability to test every possible device that will connect to one of our computers. We have said it over

FREE

**DISCOUNT & BONUS
COUPONS**

for
**PRINTERS, DISK DRIVES, DISKETTES,
SOFTWARE, BOOKS
and MORE!**

just circle

14

on your Reader Service

Card and mail it today.

or write to:

**FREE COUPONS
P.O. Box 32010
Cleveland, Ohio 44132**

just good business.



SUPPLIES

AVERY TABULABLES

1,000 3 1/2 x 15/16	8.49
3,000 3 1/2 x 15/16	14.95
5,000 3 1/2 x 15/16	19.95

TWO NEW 'OTHER MYSTERIES' BOOKS

THE CUSTOM TRS-80	24.95
MICROSOFT BASIC FASTER AND BETTER	24.95

CORVUS

TRS-80 MOD I, II, III

Controller, Case/P.S., Operating System, A&T

5 MEGABYTES	3245.00
10 MEGABYTES	4645.00
20 MEGABYTES	5545.00
MIRROR BACK-UP	725.00

SPECIALS

SPECIAL NO. 1

TRS-80 DISK AND OTHER MYSTERIES, BOX OF VERBATIM DISKS, PLASTIC LIBRARY CASE	44.50
--	-------

SPECIAL NO. 3

NEWDOS/80 2.0, BOX OF VERBATIM DISKS, PLASTIC LIBRARY CASE	149.00
--	--------

SPECIAL NO. 4

MICROSOFT BASIC COMPILER, BOX OF VERBATIM DISKS, PLASTIC LIBRARY CASE	179.00
---	--------

SPECIAL NO. 5

MICROSOFT BASIC DECODED AND OTHER MYSTERIES, BOX OF VERBATIM DISKS, PLASTIC LIBRARY CASE	49.95
--	-------

DOUBLE DENSITY SPECIAL

PERCOM DOUBLER II, NEWDOS/80, BOX OF VERBATIM DISKS, PLASTIC LIBRARY CASE	279.00
---	--------

COMMUNICATION SPECIAL MOD I & III

NOVATION MODEM, OMNITERM TERMINAL SOFTWARE, ACOUSTIC SPECIAL (CAT)	219.00
DIRECT CONNECT SPECIAL (D-CAT)	239.00
SERIAL CABLE	25.00

DISK LIBRARY SPECIAL

RACET DISKCAT CATALOGING PROGRAM, FLIP SORT (50 DISK CAPACITY), 50 STICK-ON DISK LABELS	59.95
---	-------

TRS-80 GAMES

All games are disk versions. Cassette versions may not be available.

TEMPLE OF APSHAI	34.95
HELLFIRE WARRIOR	34.95
STAR WARRIOR	34.95
RESCUE AT RIGEL	24.95
CRUSH, CRUMBLE & CHOMP	24.95
INVADERS FROM SPACE	17.95
PINBALL	17.95
STAR TREK 3.5	17.95
MISSILE ATTACK	18.95
STAR FIGHTER	24.95
Z-CHESS III	24.95
ADVENTURE NO. 1, 2, & 3	34.95
ADVENTURE NO. 4, 5, & 6	34.95
ADVENTURE NO. 7, 8, & 9	34.95
DUEL-N-ORIDS	17.95
STARFLEET ORION	21.95
INVASION ORION	21.95
OLYMPIC DECATHLON	24.95
MONTY PLAYS MONOPOLY	31.95
SARGON II	31.95
BLACKJACK MASTER	27.95
ROBOT ATTACK	17.95
GALAXY INVASION	17.95
SUPER NOVA	17.95
TUESDAY MORNING QUARTERBACK	26.95
LUNAR LANDER	18.95
THE MEAN CHECKER MACHINE	21.95
GAMMON CHALLENGER	18.95
SPACE ROCKS	18.95
PIGSKIN	17.95
ZOSSED IN SPACE	18.95
ARCADE-80	21.95
COMBAT	18.95
SPACE INTRUDERS	17.95
SILVER FLASH	17.95
MORTON'S FORK	26.95
PROJECT OMEGA	21.95

Now you can use your Epson printer without wasting computer time.

Alpha Byte is proud to introduce the Microbuffer™

Improve efficiency by adding a Microbuffer to your Epson printer.

Your computer is capable of sending data much faster than your Epson is capable of printing it. Because of this you and your computer spend a lot of time just waiting for the Epson to finish printing one line before the next can be sent.

You can recover this wasted time by installing the Microbuffer buffered Centronics-compatible parallel interface, from Practical Peripherals, Inc. It will allow you to print and process simultaneously by storing computer output in an external RAM buffer until the printer is ready for it. You regain control of the computer and may continue processing while the Epson is still printing.

MBP-16K PARALLEL INTERFACE - 16,394 BYTE BUFFER.....159.00

The MBP-16K Centronics-com-

patible parallel interface features a 16,394 byte buffer for data storage and is compatible with standard Epson cables. The MBP-16K supports all Epson printer commands and GRAFTRAX-80.

MBS-8K RS-232C SERIAL INTERFACE - 8,192 BYTE BUFFERING.....159.00

The MBS-8K is an RS-232 serial interface with an 8,192 byte buffer. The MBS-8K supports seven baud rates (300 to 19,200), hardware and X-On/X-Off handshaking, and user-selectable UART settings. The MBS-8K supports all Epson printer commands including GRAFTRAX-80.

Both the Microbuffer MBP-16K and MBS-8K are easy to install, they simply plug into the existing auxiliary interface connector inside the Epson MX-80, MX-80 F/T, and MX-100 printers. No special user software is required for control.

We guarantee everything for 30 days. If anything is wrong, return the item and we'll make it right. And, of course, we'll pay the shipping charges.

We accept Visa and Master Card on all orders; COD orders, up to \$300.00.

Add \$2.00 for standard UPS shipping and handling on orders under 50 lbs. delivered in continental U.S. Call for shipping charges over 50 lbs. Foreign, FPO and APO orders, add 15% for shipping. California add 6% sales tax.

Prices quoted are for stock on hand and are subject to change without notice.

Alpha Byte COMPUTER PRODUCTS

31245 LA BAYA DRIVE, ¹¹
WESTLAKE VILLAGE, CA 91362

To order, or for information, call:
(213) 706-0333

To use our 24-hour modem order line, call: (213) 883-8976.

"We do not support any non-TRSDOS operating system."

and over again—if a product is sold to work with a TRS-80 by someone other than Radio Shack and it does not work, you are going to have to go to that company to ask for help. That does not just apply to hardware either, but also to the operating system (DOS) and other computer programs that will run on TRS-80 computers.

I am sorry that Ms. Mooney did not realize that she would need a communications program to utilize a modem. All she had to do was ask one of our representatives what was needed to make it work and if they did not know, they would have found out for her. Also, as a regular reader of your magazine, all she had to do was take a look at Frank Derfler's excellent article "Datacom Decisions" (August 1981) as well as numerous other articles describing computer communications.

There isn't much that can be said about Scripsit not functioning with a Dvorak keyboard. Scripsit has its own keyboard driver and it was not designed to be used with a Dvorak style keyboard.

The problem with Scripsit not working in Drive 0, well, I can only guess. That guess is she booted-up under some operating system other than TRSDOS which is furnished on the Scripsit disk. When she removed her system disk and substituted the Scripsit disk, the required functions of her operating system were removed and it therefore failed to function. We know and state clearly that a "System disk must be in drive 0 at all times." Our instructions for Scripsit are for the user to place the Scripsit disk in drive 0 and boot-up from it, then enter Scripsit. After Scripsit has loaded and is running, remove the Scripsit disk and insert a System disk that you want your documents stored on. We advise that they never write to their Scripsit program disk.

Our people are familiar with, or at least can call Fort Worth to get help with, our products. We do not support nor are we familiar with any non-TRSDOS operating system and consequently, we cannot be of any help with questions regarding them. I apologize if Ms. Mooney was treated rudely in one of our stores. There is no excuse for that sort of behavior.

Not mentioned by Ms. Mooney, but worth commenting on, is her use of TEAC drives. As far as we know, TEAC disk

drives use cam-type mechanisms which are not able to run as fast as the required band type drives used in a Model III. If these type drives are used with TRSDOS (which expects to see a faster drive) then multiple problems will result.

Bottom line?? We service and support what we sell. Yes, if you "bargain hunt" you can possibly find it cheaper but, if it is a TRS-80 that contains non-Radio Shack components—well, caveat emptor.

Bill Walters
Consumer Information Manager
Tandy/Radio Shack
Fort Worth, TX

Ribbon Fix

For Okidata Microline 80 printer owners whose printers occasionally eat ribbons, here is a quick solution to the problem. Take off the gray and clear plastic cover over the print head. If the shafts on which the ribbons spin are a lot taller than the spools, you have a modified machine and the ribbon should work perfectly. If it does not work properly or if you have the short shafts, you may watch your ribbon get eaten by the gears winding the spools.

When the spool gets to the end, the rivet is supposed to slide the reverse bar across and start the spools winding in the opposite direction. The pin in the large gear which turns the spool from underneath is too small. When pulled hard the spool sometimes jumps off the pin and lets out about five inches of ribbon to dangle down into the hungry gears. The solution to the problem is to anchor the spools down to the gears so that no matter how hard the ribbon pulls on the spool, the spool will not jump off the pin turning it.

If you have the tall shafts, the fix is easy. Find two fahrenstock clips and drill them out to a size slightly smaller than the spool shafts. After the ribbon spools are in place, slide the clips down the shafts until each rests tight against the spool. When you change ribbons (which people

do not do nearly often enough) remove the clips with a pair of pliers.

If you have short shafts, you cannot just replace them. They are hot-pressed in place and come as part of an expensive complete drive unit available only from Japan. Instead, remove the spools of ribbon. Remove the clip holding the washer on. Remove the washer and drill a hole in the washer directly opposite the offset hole (see Fig. 1.) Make your hole the same

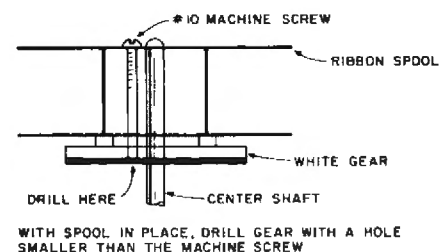

Figure 2

size and the same distance from the center as the offset hole. Reinstall the washers and clips. Place the spools back tightly on the shafts. Using the bolt cutters on your wire crimpers, cut two #10 machine screws to 11/16". Drill through the spool hole, through the hole in the washer and into the nylon gear the spool sits on. Thread the screw down through the spool until the head is snug against the spool (see Fig. 2). Now when the rivet pulls on the switching mechanism, the spool cannot pop off the shaft.

C. Howard Johnson, Director
Maine Computer Network
Mount Desert, ME

Legalized Rip-off?

Does your GM dealer refuse to work on your GM vehicle until he replaces the Sears tires you put on it?

I recently purchased a Radio Shack TRS-80 Model III computer with 16K of memory and planned to add 32K of memory and two disk drives. A few months after purchase (more than 90 days) the system would not start up properly so I took the machine to Radio Shack for repair. It came back from the "experts" with exactly the same problem. They took it back to the shop again and fixed it by replacing the 16K of memory and left out the center screw in the back which holds the chassis to the housing. I paid for the labor and the new parts (\$68.34) and asked for the original memory chips which they removed. Radio Shack's answer was they were "not available."

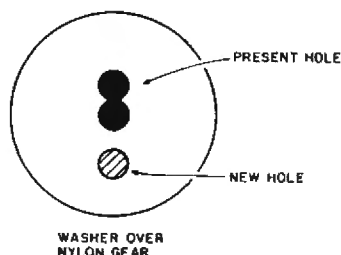

Figure 1

Does removal and replacement of customer-owned property without customer consent constitute theft or just a legalized rip-off?

Is there any evidence in the industry that Radio Shack's memory chips (Motorola in my case) are as good or better than semiconductor industry standards?

"Are Radio Shack's memory chips as good as or better than semiconductor industry standards?"

When I decided to add two disk drives I purchased 32K of NEC memory chips P/N 4116 and put it into the memory board sockets. Four times I ran a memory verification program which checked each memory location 256 times without error. Then I took the machine to Radio Shack for installation of the disk drives. The clerk told me that the repair center (which appears to be a subcontractor to Radio Shack) would remove my memory and replace them with Radio Shack memory (at a cost of \$200 versus the \$38 I had paid) before installing the disk drives. I did not go for this rip-off (under the guise of company policy) so I took the machine home and removed the added memory before

taking it to another outlet to have the disk drives added.

Only a few computer shops do this type of work so it appears the Radio Shack customers will be forced to put up with this customer-be-damned attitude until more independent service centers are established.

Meanwhile I wonder if the above policy does not constitute a restraint of trade. Are other Radio Shack customers experiencing this same type of difficulty? Are there others who would be interested in pursuing a class action suit?

Richard L. Bates
Camillus, NY

Radio Shack Replies

Richard L. Bates' letter voices two basic complaints:

We did not return to him the chips which were replaced in his TRS-80. Based on the price he paid, and labor, we probably replaced only two or three chips, not the whole set. We will always return parts, if requested ahead of time. He probably did not ask until the chips had been thrown away, and truly were "not available."

Our repair center was wrong to indicate that they could not install Radio Shack disk drives in a Model III because it contained another vendor's memory chips. Our policy on non-Radio Shack RAMs is that we will:

- Replace defective chips as required

when we service a computer. Defectives are returned if requested when the computer is brought in for service.

● If requested, we will call the customer with an estimate before doing the work. If he chooses to do it himself, we will stop, return the computer, and charge him a checkout fee.

Any repair service, for any product, can be expected to remove and replace defective parts. It is part of the repair process and hardly a rip-off. As to our chips, we test and screen them quite thoroughly, regardless of vendor, and we believe them to be of top quality. But any chips, theirs or ours, can go out.

If Mr. Bates has trouble with a Radio Shack Repair Center, and will furnish me with all the details, I will be happy to do all I can to ensure his satisfaction.

Ed Juge, Director
Computer Merchandising
Tandy/Radio Shack
Fort Worth, TX

Dissatisfied Customer

I am an enthusiastic owner of a TRS-80 computer. As such I am always on the look-out for new programs and products.

Recently I ordered three programs and a joystick from Big Five Software, a company which advertises in *80 Microcomputing*. Two weeks after I sent the order, I received a form letter stating that two of the programs were no longer available

Continued on page 24

AUTHORIZED TRS 80® DEALER #R491

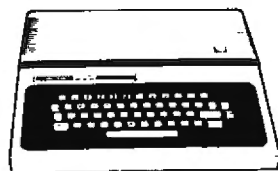

TRS-80[®] Color Computer With
Extended Color BASIC



26 - 1062
Model III 16K RAM
Model III, BASIC

\$839.00

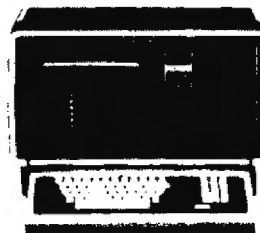

26 - 4002
Model II, 64K

WE ACCEPT CHECK, MONEY ORDER, OR PHONE ORDERS WITH VISA OR MASTERCARD. SHIPPING COSTS WILL BE ADDED TO CHARGE ORDERS. DISK DRIVES, PRINTERS, PERIPHERALS, AND SOFTWARE—YOU NAME IT, WE'VE GOT IT. WRITE OR CALL FOR OUR COMPLETE PRICE LIST.

C & S ELECTRONICS, LTD. 32 EAST MAIN ST. MILAN, MICH. 48160

✓ 138

(313) 439-1508 (313) 439-1400

C & S ELECTRONICS MART IS AN AUTHORIZED TRS 80[®] SALES CENTER STORE #R491

WHY

IS THE ALPHA JOYSTICK SUCH A SUCCESS ?

Because of games like these.

THE LATEST BLAST FROM BIG FIVE...

NEW! **DEFENSE COMMAND**



Actual unretouched photos

DEFENSE COMMAND



Big Five has done it again! Now the most popular arcade game of all time has a fascinating new twist. The Invaders are back! You are alone, valiantly defending the all important nuclear fuel cannister stockpile from a convoy of thieving aliens who repeatedly break off and attack in precision formations. An alien passes your guard, swiftly snatching up a cannister and flying straight off. Quick! you have one last chance to blast him out of the sky. Great action and sound!



SCARFMAN



SCARFMAN



THE LATEST ARCADE CRAZE now runs on your TRS-80.

It's eat or be eaten. You control Scarfman around the maze, gobbing up everything in your path. You attempt to eat it all before the monsters devour you. Difficulty increases as game progresses. Excellent high speed machine language action game. From The Cornsoft Group. With sound.

CAUTION: Played with the Alpha Joystick, Scarfman may become addictive.



SUPER NOVA®

Asteroids float ominously around the screen. You must destroy the asteroids before they destroy you! (Big asteroids break into little ones.) Your ship will respond to thrust, rotate, hyperspace and fire. Watch out for that saucer with the laser! As reviewed in May 1981 Byte Magazine.



LUNAR LANDER

As a vast panorama moonscapes scrolls by, select one of many landing sights. The more perilous the spot, the more points scored—if you can land safely. You control LEM main engines and side thrusters. Absolutely the best use of TRS-80 graphics we have ever seen! From Adventure International. With sound.

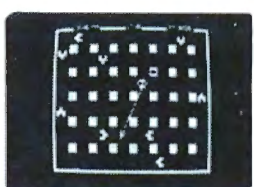

ATTACK FORCE®

As your ship appears on the bottom of the maze, eight alien ships appear on the top, all traveling directly at you! You move toward them and fire missiles. But the more aliens you destroy, the faster the remaining ones become. If you get too good you must endure the "Flagship"... With sound effects!



COSMIC FIGHTER®

Your ship comes out of hyperspace under a convoy of aliens. You destroy every one. But another set appears. These seem more intelligent. You eliminate them, too. Your fuel supply is diminishing. You must destroy two more sets before you can dock. The space station is now on your scanner... With sound!



METEOR MISSION II®

As you look down on your view, astronauts cry out for rescue. You must maneuver through the asteroids & meteors. (Can you get back to the space station?) Fire lasers to destroy the asteroids, but watch out, there could be an alien FLAGSHIP lurking. Includes sound effects!

TALKING ROBOT ATTACK

INCREDIBLE! This amazing game actually TALKS without a speech synthesizer, through the cassette AUX plug.

You are armed with just a hand held laser. In a remote section of the space station you encounter armed robots, some march towards you, some wait around corners. Watch out, the walls are electrified. Zap as many robots as you dare before escaping into a new section where more robots await you. The struggle continues. With Joystick action and **VOICE OUTPUT**, this game will amaze you.

VOICE OUTPUT!

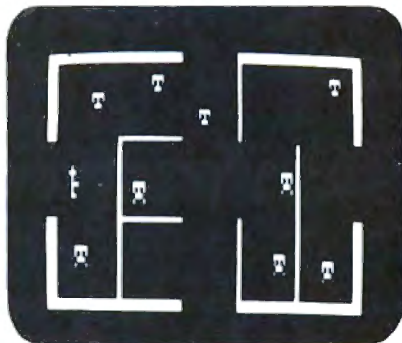

GAME PRICES

16K Level 2, Mod 1 + Mod 3 Cassette: \$15.95
32K Level 2, Mod 1 + Mod 3 Diskette: \$19.95
All games on this page are "Alpha Joystick Compatible." They may be played with or without joystick (using arrow keys).

**Toll Free
Order Line
(800)
221-0916**

ALPHA Products

79-04 Jamaica Ave., Woodhaven, N.Y. 11421

(212) 296-5916

ADD \$2.00 PER ORDER FOR SHIPPING AND HANDLING. WE ACCEPT VISA, MASTERCARD, CHECKS, M.O. C.O.D. ADD \$3.00 EXTRA. NY RESIDENTS ADD SALES TAX. OVERSEAS, F.P.O. APO: ADD 10%. DEALER DISCOUNTS AVAILABLE.





A Sweet Deal:

When you buy
an Alpha Joystick
and games together,
deduct up to \$14.00
from your order.



(Model I
version
shown)

MODEL 1 OR 3

ONLY
\$39.95

MODEL I OR III. SPECIFY WHEN ORDERING. PRICE INCLUDES ATARI JOYSTICK + ALPHA INTERFACE + INSTRUCTIONS + DEMO PROGRAM LISTING.

THE ALPHA JOYSTICK

Joystick + 1 game : Deduct \$ 6.00
Joystick + 2 games: Deduct \$12.00
Joystick + 3 games: Deduct \$14.00

The Alpha Joystick gives you real arcade action. Game producers know that it makes great games better. That's why each month more games from more producers are "Alpha Joystick Compatible."

There has never been a better time to get your Alpha Joystick. With so many excellent action games to choose from it's time to step up to joystick power.

You will find the Alpha Joystick simple to use. Just plug it in. No modification, wiring or batteries are required, and it's fully compatible with any other TRS-80 accessories. The instructions are clear and complete, we even show you how easy it is to experiment in

BASIC (A = INP(0) reads stick) and to convert BASIC programs for joystick control.

MODEL I - Plugs into any Level II keyboard (40 pin card edge in the back) or expansion interface (left side, next to printer port). Our latest design has a "mode" switch for compatibility with the many different producers of joystick compatible games.

MODEL III — Works with any Model III BASIC system. It plugs into the 50 pin I/O bus (largest edge connector underneath, centered toward the rear). It will work with "Joystick Compatible" Model III games from any producer.

"If you purchase Alpha's Joystick you get the exquisite pleasure of enjoying (action games) to the limit of arcade-style realism."

— 80 Microcomputing
80 Reviews, Jan '82

**14 DAY MONEY BACK
GUARANTEE:** If you are not delighted, return it within 14 days for a prompt and courteous refund.

**Toll Free
Order Line**

ORDERS ONLY. HOURS: 9 AM - 5:30 PM, E.S.T.
FOR INFO CALL: (212) 296-5916

800-221-0916

ADD \$2.00 PER ORDER FOR SHIPPING AND HANDLING. WE ACCEPT VISA, MASTERCARD, CHECKS, M.O. C.O.D. ADD \$3.00 EXTRA. NY RESIDENTS ADD SALES TAX. OVERSEAS, FPO, APO: ADD 10%. DEALER DISCOUNTS AVAILABLE



ALPHA Products

79-04 Jamaica Ave., Woodhaven, N.Y. 11421 (212) 296-5916

80 AID

Shading Patterns

We have a Model II and a Radio Shack Plotter/Printer which we use to plot maps digitized from a Summagraphics "Bit Pad One." When making certain kinds of maps, such as choroplethics, we would like to be able to fill in the polygons with various shading patterns. The programming for this is beyond our level of experience. Are there any readers with any programming capability to help us with this problem? We would also like to hear from other Plotter/Printer users to exchange ideas and experiences in general in this relatively undeveloped area.

*Steve Maynard
Geography Extension Program
#8 Stewart Hall
University of Missouri
Columbia, MO 65211*

Line-feed for VisiCalc

I have a Model I and VisiCalc, which does not have all the pluses that the Model II and III versions have. It is a fantastic program, but I would like to be able to create a program line-feed, without having to wait for the print-head to travel across a blank line. Has anyone accomplished this?

*Paul E. Shafer
Ahsahka, ID 83520*

Move those feet!

I read with interest Betty Hollins' article "Two Transfers Please" (80 *Microcomputing*, February 1982). I also have Micromusic, but I use it infrequently due to inability to successfully load it to disk as well as the limited tape I/O for music text. I am writing to see if any of your readers have similar success with two other products: Raaka-Tu and Dancin Demon.

Although I have NEWDOS 2.1, I have not been able to create a copy of

Raaka-Tu on disk that will run—the transfer works but the output is useless.

I would like to modify Dancin Demon to support disk I/O of music and routines and I would like to add editor enhancements to allow insertion or deletion of characters in the middle of the music or dance routine. If any of your readers have developed or know of such enhancements I would be interested in hearing from them.

*Robert Alston
2385 Placid Way
Ann Arbor, MI 48105*

Printer Patch

I have a TRS-80 Model I with one disk drive and 32K, modified by Radio Shack for lowercase use. I have been using a Selectric typewriter modified by Computer Devices of California. This system works well as a word processor using the Electric Pencil with the Penmod patch.

I have tried to use the Radio Shack Scripsit, but am unable to get a proper typewriter carriage return. Does anyone know of a patch that would enable me to use my setup with Scripsit?

*Milton Tuerk, M.D.
250 Hospital Road
Patchogue, L.I., NY 11772*

Type Font Wanted

We need a daisy-wheel printer print wheel with an Orator type font. A Bulletin type font would be an acceptable substitute.

We put the roster of our conference attendees on the TRS-80 Model II and need some way to print the badges in a large size type that is readable.

Any suggestions on where we might purchase this would be appreciated.

*Harriett Heineman
Retail Advertising Conference
67 East Oak St.
Chicago, IL 60611*

Digital Group Printer Interface

I am a beginning programmer. I have been trying unsuccessfully to interface a Digital Group printer, model DMTP-6, to my TRS-80 Model I Level II.

I have 48K, one disk drive and use TRSDOS 2.3 and TRSDOS 2.3B operating systems. I need to know the wiring connections from printer to TRS-80. Will this printer work without additional software?

*Jim McLeod
10371 Ainsworth Crescent
Richmond, British Columbia
Canada V7A 3V5*

G or S?

While my Epson MX-70 is an excellent printer on the whole, the lowercase g looks almost identical to the lowercase s, and my clients (I am a translator) are highly dissatisfied.

Does anyone have any ideas for upgrading this printer (possibly by switching to a different ROM and a new printing head) that will either give me descenders or else a small g that is the same shape as the capital one, but simply smaller?

*Dr. S. Himelstein
Maalot Dafna 45/5
Jerusalem
Israel*

Super Model I

I own a TRS-80 Model I. I would like to use several of the Model III's features on my Model I. How do I program repeating keys, screen print, and shift-lock (for output to my line printer)? How can I CLOAD from cassette 2? How can I patch Debug so it will work with the Expansion Interface?

*Al Kiss
29 Hawkedon Circle
Rexdale, Ontario
Canada*

NOW MODEL I AND MODEL III!

Now Model III users can take advantage of the ALPHA I/O system too. Our new MOD III/I BUS CONVERTER allows most port based Model I accessories (such as our ANALOG-80, INTERFACER 2 and INTERFACER-80) to connect to the Model III bus. MOD III/I BUS CONVERTER, complete with all connectors, only \$39.95.



2 Printers?

PRINTSWITCH

Have 2 printers on line at all times and select printer 1 or 2 by means of a conveniently located switch. End the problem of constantly plugging and unplugging printer cables. PRINTSWITCH is a compact module that plugs onto the parallel printer port of your TRS-80 and provides an edge connector for each of your two printers. It works with any two types of printers: dot matrix, daisy wheel, plotters, TRS-80 converted electrics, etc. Assembled, tested, ready to use with connector and instructions. For Model I or III (please specify). ONLY \$59.00

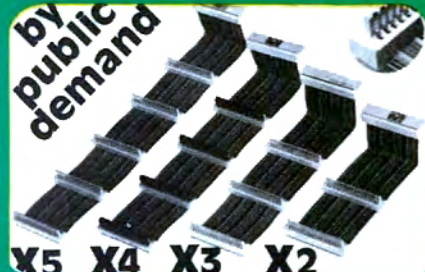
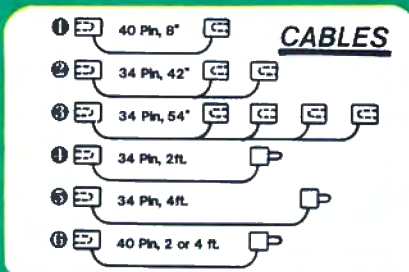

X5 X4 X3 X2

SUPERIOR QUALITY REPLACEMENT & EXTENSION CABLES

Highest quality cable and high force, gold plated contacts ensure the utmost in connection reliability

- 1 KEYBOARD TO EXPANSION INTERFACE \$21
 - 2 DISK DRIVE CABLE FOR 1 OR 2 DRIVES \$32
 - 3 DISK DRIVE CABLE FOR 3 OR 4 DRIVES \$45
 - 4 DISK DRIVE CABLE EXTENDER \$22
 - 5 PRINTER CABLE EXTENDER \$24
 - 6 40 PIN BUS EXTENDER - 2ft \$22 4ft. \$24
- Custom cable configurations are also available. Call us

YOU ASKED FOR IT: "EXPANDABUS" X1, X2, X3 AND X4.

CONNECT ALL YOUR TRS-80 DEVICES SIMULTANEOUSLY on the 40 pin TRS-80 bus. Any device that normally plugs into the keyboard edge connector will also plug into the "EXPANDABUS". The "X4" is shown with protective covers (included). The TRS-80 keyboard contains the bus drivers (74LS367) for up to 20 devices, more than you will ever need. Using the E/I, it plugs either between KB and E/I or in the Screen Printer port. Professional quality, gold plated contacts. Computer grade 40 conductor ribbon cable. X2 \$29 X3 \$44 X4 \$59 X5 \$74. Custom configurations are also available. call us



new

ANALOG-80 A WORLD OF NEW APPLICATIONS POSSIBLE
8 DIGITAL MULTIMETERS PLUGGED INTO YOUR TRS-80!!! Measure Temperature, Voltage, Current, Light, Pressure, etc. Very easy to use, for example, let's read input channel #4. 10 OUT 0-4 Selects input #4 and also starts the conversion. 20 A INP/D Puts the result in variable A. Voilà! Specifications: Input range 0-5V to 0-500V. Each channel can be set to a different scale. Resolution 20mV (on 5V range). Accuracy 8 bits (5%). Port Address jumper selectable. Plugs into keyboard bus or E/I (screen printer port). Assembled and tested. 90 day warranty. Complete with power supply, connector, manual. \$139



TIME DATE 80 REAL-TIME CLOCK/CALENDAR MODULE

Keeps quartz accurate time for 3 years on 2 replaceable AAA batteries (not included). Gives MO/DATE YR DAY of WEEK HR MIN SEC and AM/PM. Features INTELLIGENT CALENDAR and even provides for Leap Year. This compact module simply plugs into rear of Keyboard or side of Expansion Interface (may be slipped inside E/I). Includes cassette software for setting clock and patching to any DOS (including NEWDOS 80 2.0). Optional Y connector allows for further expansion. For Model I. Fully assembled and tested. Complete with instructions and cassette. ONLY \$95.00. Y system and \$12.00.

GREEN SCREEN WARNING

IBM and all the "biggies" are using green screen monitors. Its advantages are now widely advertised. We feel that every TRS-80 user should enjoy the benefits it provides. But WARNING: all Green Screens are not created equal. Here is what we found:

- Several are just a flat piece of standard colored Lucite. The green tint was not made for this purpose and is judged by many to be too dark. Increasing the brightness control will result in a fuzzy display.
- Some are simply a piece of thin plastic film taped onto a cardboard frame. The color is satisfactory but the wobbly film gives it a poor appearance.
- One "optical filter" is in fact plain acrylic sheeting.
- False claim: A few pretend to "reduce glare". In fact, their flat and shiny surfaces (both film and Lucite type) ADD their own reflections to the screen.
- A few laughs: One ad claims to "reduce screen contrast". Sorry gentleman but it's just the opposite. One of the Green Screen's major benefits is to increase the contrast between the text and the background.
- Drawbacks: Most are using adhesive strips to fasten their screen to the monitor. This method makes it awkward to remove for necessary periodical cleaning. All (except ours) are flat. Light pens will not work reliably because of the big gap between the screen and the tube.
- Many companies have been manufacturing video filters for years. We are not the first (some think they are), but we have done our homework and we think we manufacture the best Green Screen. Here is why:
 - It fits right onto the picture tube like a skin because it is the only CURVED screen MOLDED exactly to the picture tube curvature. It is cut precisely to cover the exposed area of the picture tube. The fit is such that the static electricity is sufficient to keep it in place! We also include some invisible reusable tape for a more secure fastening.
 - The filter material that we use is just right, not too dark nor too light. The result is a really eye pleasing display.
- We are so sure that you will never take your Green Screen off that we offer an unconditional money-back guaranty. Try our Green Screen for 14 days. If for any reason you are not delighted with it, return it for a prompt refund.
- A last word: We think that companies, like ours, who are selling mainly by mail should list their street address, have a phone number (for questions and orders), accept CODs, not every one likes to send checks to a PO box, offer the convenience of charging their purchase to major credit cards. How come we are the only green screen people doing it? Order your ALPHA GREEN SCREEN today \$12.50

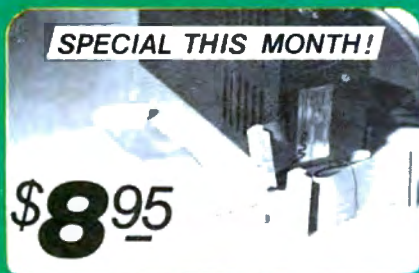

SPECIAL THIS MONTH!

\$8.95

DISK DRIVE EXTENDER CABLE, FREE YOUR MINI-DRIVES.

End the daisy-chain mess once and for all. Fits all mini-drives: Percom, Aerocomp, Shugart, Micropolis, MTI, Vista, Pertec, Siemens, BASF. Easy to install: just remove the drive cover, plug in the EXTENDER CABLE and replace the cover. Now you can change and move your drives without disassembly. Keep the cover on and the dust out. High reliability gold plated contacts, computer grade 34 conductor cable. Tested and guaranteed.

Get one for each drive ONLY \$8.95

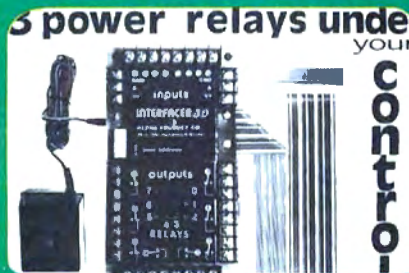

INTERFACER-80 the most powerful Sense/Control module

- 8 industrial grade relays, single pole double throw isolated contacts. 2 Amp @ 125 Volts TTL latched outputs are also accessible to drive external solid state relays.
- 8 convenient LEDs constantly display the relay states. Simple "OUT" commands (in basic) control the 8 relays.
- 8 optically-isolated inputs for easy direct interfacing to external switches, photocells, keypads, sensors, etc. Simple "INP" commands read the status of the 8 inputs. Selectable port address. Clean, compact enclosed design. Assembled, tested. 90 days warranty. Price includes power supply, cable, connector, superb user's manual. \$159



85-71 79 St. WOODHAVEN N.Y. 11421

Info and order: (212) 296-5916

✓ 17 ADD \$2.50 PER ORDER FOR SHIPPING AND HANDLING. ALL ORDERS SHIPPED FIRST CLASS MAIL. WE ACCEPT VISA, MASTER CHARGE, CHECKS, M.O. COD. ADD \$2.00 EXTRA. QUANTITY DISCOUNTS AVAILABLE. N.Y. RESIDENTS ADD SALES TAX.

Continued from page 19

because of agreements Big Five Software has with Atari. They credited my account for the full amount of my check. They cashed my check, but they did not send that part of the order that they were able to fill, namely, the third program and the joystick.

Robert Bauman
Laurel Springs, NJ

Big Five Software Replies

Atari has been cracking down on companies with games that play like some of their games (see "Atari targets software pirates," 80 News, March 1982). Atari threatened us with lawsuits for our "Galaxy Invasion" and "Robot Attack." While our attorneys are deciding who is right, we have stopped producing and selling those two games to comply with Atari's demands.

We offer a quantity discount for multiple items ordered. Mr. Bauman ordered four items (two were Robot and Galaxy), which entitles him to a 15 percent discount. Since we could only sell him two items (which would reduce his quantity discount), we gave him the choice to accept only two items at a lower discount, or cancel his order completely. Mr. Bauman completely misunderstood, saying we "didn't bother" to send the other two items.

Bill Hogue, President
Big Five Software
Van Nuys, CA

Cutting Room Goblins

There is a gremlin in the 80 Micro paste-up room. Several paragraphs of my article "In Praise of Outlines" were turned around. On page 205, the paragraph following the bold heading Define the Task should appear just before the bold heading Outline the Procedure on page 206. The paragraph that should have appeared on page 205 reads as follows:

"This program will count to 10 by fives, giving the square roots of the numbers as we go along." There, we have defined the task. We know exactly what we are going

```
2030 BS="":INPUT"NAME: ";BS
2050 BS="":INPUT"ADD: ";BS
2070 BS="":INPUT"CITY: ";BS
2090 BS="":INPUT"STATE: ";BS
2110 BS="":INPUT"ZIP: ";BS
```

Program Listing 2

to do. On this small sample you might think that you do not have to define this simple task. But what about longer programs such as a mailing list? What things do you want your mailing list to do? Do you want to be able to add or delete names? Do you want to be able to make changes or sort alphabetically by names or towns or by zip codes? In this example the need for definition is obvious.

I have also made some changes to the program since it was published. On line 40 and 5000 the For...Next loops should read FOR A=1 TO F+3 STEP4. Alter the following lines as shown in Program Listing 2. With these changes you should be able to learn in 15 minutes what it took me 2½ years to figure out.

The program I presented was not intended as an applications program, but as a sample of programming method. The full-fledged mail list program is available through Futureview Software, PO Box 1295, Joplin, MO 64802.

Dennis Drew
Joplin, MO

Newsprint Update

The March 1982 issue of 80 Microcomputing carried a review of our Newsprint word processor. That review contained several statements that were flat-out false, misleading to your readers, and potentially very damaging to our sales. I appreciate your willingness to allow me this opportunity to respond to those errors, as follows:

• "There is no way to look up what you want to do." This is stated in a paragraph that insinuates our manual is like the Radio Shack Level II Manual. Now, our manual has a table of contents, an index, a section called "How To . . .", two chapters of commands in alphabetical sequence, and hundreds of cross-references throughout the text. If that isn't sufficient to let someone look up what he wants to do, what is? All other reviews have raved about our documentation and said it is the best ever written for a microcomputer. Actually, even this 80 review said that "Newsprint has a fantastic documentation...with a table of contents and index." And then it goes right on to say there's no way to look up what you want to do. Though obviously contradictory, many of your readers will remember only that derogatory statement.

• "The greatest page number is 999. . ." The upper limit is 32767 (although I admit I never tried a number above 9999), and while even 999 is more than most peo-

Quality Percom products are available from the following authorized Percom retailers. If a retailer is not listed for your area, call Percom toll free at 1-800-527-1222 for the address of a nearby retailer, or to order directly from Percom

MICRO-COMPUTER SYSTEMS INC	Hot Springs	(501) 623-5200
ARIZONA		
SIMITEK	Tucson	(602) 323-9391
CALIFORNIA		
ALPHA-BYTE STORES	Chabasco	(213) 883-8594
BERKELEY MICRO-COMPUTERS	Berkeley	(415) 748-7122
COMPUTER INFORMATION EXCHANGE	San Luis Rey	(714) 757-4849
COMPUTER SERVICE CENTER	Hollywood	(213) 851-3434
DESMAR ELECTRONICS	Santa Clara	(408) 988-2208
HOBBYWORD	Northridge	(213) 886-9200
DISTRICT OF COLUMBIA		
THE PROGRAM STORE	Washington	(202) 337-4691
FLORIDA		
ENTRON, INC.	Largo	(813) 586-5012
MICROSYSTEMS SOFTWARE, INC.	Hollywood	(305) 983-3390
GEORGIA		
COMMERCIAL DATA PRODUCTS	Atlanta	(404) 325-7800
HAWAII		
COMPUTER CENTER	Honolulu	(808) 488-2171
IDAHO		
OFFICE MAGIC COMPUTERS	Boise	(208) 376-4613
IDAHO MICRO-COMPUTER	Buhl	(208) 543-6292
ILLINOIS		
GARCIA & ASSOCIATES	Chicago	(312) 762-9750
KANSAS		
BESC OFF ELECTRONICS	Shawnee	(913) 288-7633
CARDENS, INC.	Hutchinson	(316) 649-8261
DATA SERVICES, INC.	Wichita	(316) 838-9021
KENTUCKY		
COMPUTER MAGIC	Covington	(502) 893-9334
MASSACHUSETTS		
OMNITEK	Tewksbury	(617) 851-4580
MARYLAND		
DAMASCUS, C. B.	Damascus	(301) 253-2101
MICHIGAN		
ALTERNATE SOURCE	Lansing	(517) 487-3358
MINNESOTA		
THE CODE ROOM	Eden Prairie	(612) 934-1826
MISSOURI		
LEMBERGER CO.	Vienna	(314) 422-3353
NEBRASKA		
COLUMBUS TV ELECTRONICS	Columbus	(402) 564-5531
	Lincoln	(402) 423-7771
NEW JERSEY		
CHANNEL (HARD) SHACK	Medford	(609) 654-7454
DA & D SALES	Bloomfield	(201) 751-8444
NEVADA		
PC'S COMPUTER	Las Vegas	(702) 870-4138
NEW YORK		
H & E COMPUTRONICS	Spermy Valley	(914) 425-1535
MICRO-RD SYSTEMS	Brooklyn	(212) 748-3236
PROGRAMS UNLIMITED	Yonkers	(909) 645-6038
STONY CLOUD	New York City	(212) 391-8337
DATASCAN COMPUTER SYSTEMS, INC.	Selden	(516) 698-6285
NORTH CAROLINA		
HOLIDAY MFG.	Greensboro	(919) 274-6346
OHIO		
FEEDMAN ENTERPRISES	Akron	(216) 724-5583
MPS	Wadsworth	(216) 336-2771
PENNSYLVANIA		
COMPUTER ANALYSIS	New Brighton	(412) 846-9323
SUNRISE ELECTRONICS	Chambersburg	(717) 264-8214
TENNESSEE		
COMPUTER WORLD, INC.	Nashville	(615) 244-6094
TEXAS		
PERCOM COMPUTER CENTER	Richardson	(214) 690-0207
COMPUTER TO GO	Austin	(512) 472-8926
BREZZI QSD, INC.	Dallas	(214) 484-2976
TEXAS COMPUTER SYSTEMS	Arlington	(817) 274-5625
UTAH		
MICRO-MNEMONICS	Sunset	(801) 825-9317
WASHINGTON		
COMPUTER SERVICES	Kenneth	(509) 792-9759
NORTHWEST COMPUTER SERVICE	Bellevue	(206) 454-4979
WEST VIRGINIA		
BURCO DISTRIBUTORS	Huntington	(804) 453-6387
WISCONSIN		
BYTE SHOP MILWAUKEE	Crossfield	(414) 281-7004
FINAMORES	Marshfield	(715) 784-9619
FOREIGN DEALERS		
AUSTRALIA		
DICK SMITH ELECTRONICS	P.O. Box 321 North Ryde NSW2113	
CANADA		
ALPHA ONE	Edmonton	(403) 454-8409
VALERIE AND ASSOC.	Geoph. Ontario	(416) 624-4899
DVR ELECTRONICS	Surrey, B.C.	(604) 576-1045
COTS MICROSYSTEMS LTD.	Ottawa	(613) 741-7937
MICRO-COMPUTER ENTERPRISES, INC.	Pharming	(416) 839-4561
MICRO MART	Montreal	(514) 731-9886
MEXICO		
CIBERMATIC S.A.	Mexico	(905) 592-3433
COMPUTADORAS Y ASesoramiento	Rio Panuco 14 Mexico D.F.	
DOMINICAN REPUBLIC		
RADIO SHACK	Santo Domingo	(809) 565-9121

Continued on page 30

TRS-80* COMPUTING EDITION

©1981 Percom Data Co., Inc.

The Percom Peripheral

35 cents

Percom's DOUBLER II* tolerates wide variations in media, drives

GARLAND, TEXAS — May 22, 1981 — Harold Mauch, president of Percom Data Company, announced here today that an improved version of the Company's innovative DOUBLER[®] adapter, a double-density plug-in module for TRS-80* Model I computers, is now available.

Reflecting design refinements based on both theoretical analyses and field testing, the DOUBLER II[®], so named, permits even greater tolerance in variations among media and drives than the previous design.

Like the original DOUBLER, the DOUBLER II plugs into the drive controller IC socket of a TRS-80 Model I Expansion Interface and permits a user to run either single- or double-density diskettes on a Model I.

With a DOUBLER II installed, over four times more formatted data — as much as 364 Kbytes — can be stored on one side of a five-inch diskette than can be stored using a standard Tandy Model I drive system.

Moreover, a DOUBLER II equips a Model I with the hardware required to run Model III diskettes.

(Ed. Note: See "OS-80[™]: Bridging the TRS-80* software compatibility gap" elsewhere on this page.)

The critical clock-data separation circuitry of the DOUBLER II is a proprietary design called a ROM-programmed digital phase-lock loop data separator.

According to Mauch, this design is more tolerant of differences from diskette to diskette and drive to drive, and also provides immunity to performance degradation caused by circuit component aging.

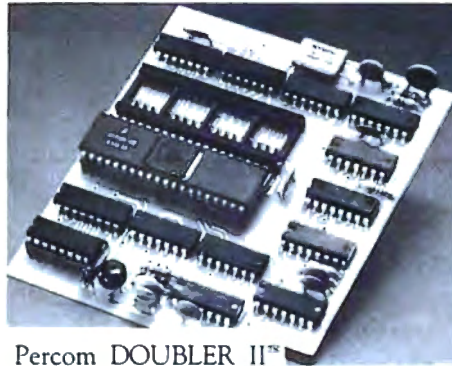

Percom DOUBLER II[™]

Mauch said "A DOUBLER II will operate just as reliably two years after it is installed as it will two days after installation."

The digital phase-lock loop also eliminates the need for trimmer adjustments typical of analog phase-lock loops.

"You plug in a Percom DOUBLER II and then forget it," he said.

The DOUBLER II also features a refined Write Precompensation circuit that more effectively minimizes the phenomena of bit-and-peak-shifting, a reliability-impairing characteristic of magnetic data recording.

The DOUBLER II, which is fully software compatible with the previous DOUBLER, is supplied with DBLDOS[™], a TRSDOS* compatible disk operating system.

The DOUBLER II sells for \$219.95, including the DBLDOS diskette.

Now \$169.95!

Circuit misapplication causes diskette read, format problems. High resolution key to reliable data separation

GARLAND, TEXAS — The Percom SEPARATOR[™] does very well for the Radio Shack TRS-80* Model I computer what the Tandy disk controller does poorly at best: reliably separates clock and data signals during disk-read operations.

Unreliable data-clock separation causes format verification failures and repeated read retries.

CRC ERROR—TRACK LOCKED OUT

The problem is most severe on high-number (high-density) inner file tracks.

As reported earlier, the clock-data separation problem was traced by Percom to misapplication of the internal separator of the 1771 drive controller IC used in the Model I.

The Percom Separator substitutes a high-resolution digital data separator circuit, one which operates at 16 megahertz, for the low-resolution one-megahertz circuit of the Tandy design.

Separator circuits that operate at lower frequencies — for example, two- or four-

megahertz — were found by Percom to provide only marginally improved performance over the original Tandy circuit.

The Percom solution is a simple adapter that plugs into the drive controller of the Expansion Interface (EI).

Not a kit — some vendors supply an untested separator kit of resistors, ICs and other paraphernalia that may be installed by modifying the computer — the Percom SEPARATOR is a fully assembled, fully tested plug-in module.

Installation involves merely plugging the SEPARATOR into the Model I EI disk controller chip socket, and plugging the controller chip into a socket on the SEPARATOR.

The SEPARATOR, which sells for only \$29.95, may be purchased from authorized Percom retailers or ordered directly from the factory. The factory toll-free order number is 1-800-527-1222.

Ed. note: Opening the TRS-80 Expansion Interface may void the Tandy limited 90-day warranty.

The Percom DOUBLER II is available from authorized Percom retailers, or may be ordered direct from the factory. The factory toll-free order number is 1-800-527-1222.

Ed. note: Opening the TRS-80 Expansion Interface may void the Tandy limited 90-day warranty.

All that glitters is not gold

OS-80[™] Bridging the TRS-80* software compatibility gap

Compatibility between TRS-80* Model I diskettes and the new Model III is about as genuine as a gold-plated lead Kruggerand.

True, Model I TRSDOS* diskettes can be read on a Model III. But first they must be converted and re-recorded for Model III operation.

And you cannot write to a Model I TRSDOS* diskette. Not with a Model III. You cannot add a file. Delete a file. Or in any way modify a Model I TRSDOS diskette with a Model III computer.

Furthermore, your converted TRSDOS diskettes cannot be converted back for Model I operation.

TRSDOS is a one-way street. And there's no re-treating. A point to consider before switching the company's payroll to your new Model III.

Real software compatibility should allow the direct, immediate interchangeability of Model I and Model III diskettes. No read-only limitations, no conversion/re-recording steps and no chance to be left high and dry with Model III diskettes that can't be run on a Model I.

What's the answer? The answer is Percom's OS-80[™] family of TRS-80 disk operating systems.

OS-80 programs allow direct, immediate interchangeability of Model I and Model III diskettes.

You can run Model I single-density diskettes on a Model III: install Percom's plug-in DOUBLER[™] adapter in your Model I, and you can run double-density Model III diskettes on a Model I.

There's no conversion, no re-recording. Slip an OS-80 diskette out of your Model I and insert it directly in a Model III.

And vice-versa. Just have the correct OS-80 disk operating system — OS-80, OS-80D or OS-80/III — in each computer.

Moreover, with OS-80 systems, you can add, delete, and update files. You can read and write diskettes regardless of the system of origin.

OS-80 is the original Percom TRS-80 DOS for BASIC programmers.

Even OS-80 utilities are written in BASIC. OS-80 is the Percom system about which a user wrote, in Creative Computing magazine, "... the best \$30.00 you will ever spend."[†]

Requiring only seven Kbytes of memory, OS-80 disk operating systems reside completely in RAM. There's no need to dedicate a drive exclusively for a system diskette.

And, unlike TRSDOS, you can work at the track sector level, defining and controlling data formats — in BASIC — to create simple or complex data structures that execute more quickly than TRSDOS files.

The Percom OS-80 DOS supports single-density operation of the Model I computer — price is \$29.95; the OS-80D supports double-density operation of Model I computers equipped with a DOUBLER or DOUBLER II; and, OS-80/III — for the Model III of course — supports both single- and double-density operation. OS-80D and OS-80/III each sell for \$49.95.

PRICES AND SPECIFICATIONS SUBJECT TO CHANGE WITHOUT NOTICE.

PRICES DO NOT INCLUDE HANDLING AND SHIPPING.

PERCOM DATA COMPANY, INC. 11220 Pagemill Road Dallas, Texas 75243 (214) 340-7081

*Trademark of Percom Data Company, Inc. *TRS-80 and TRSDOS are trademarks of Tandy Corporation which has no relationship to Percom Data Company. †Creative Computing Magazine, June, 1980, page 26.

See List of Advertisers on page 354

80 Microcomputing, May 1982 • 25

80 DEBUg

Day of the Week Bugs

Since my article "If this is Tuesday, it must be..." appeared in the January 1982 issue of *80 Microcomputing*, I have received many requests for clarification of the Program Listing. Two lines are printed incorrectly in the listing on page 308. Line 130 should read: `130 H = INT(5*Y/4)` and line 170 should read `170 W = W - INT(W/7)*7`.

Walter J. Atkins, Jr., Ph.D.
QTRS 4410A

USAF Academy, CO 80840

Array I/O Bugs

The program listings accompanying my article "Array I/O" (*80 Microcomputing*, January 1982) contain several errors.

Line 460 of Program Listing 1 should read

```
460 CALL01F8H ;CASSETTE OFF
```

Line 860 should read

```
860 EXIT CALL 01F8H ;CASSETTE OFF
```

Delete lines 470 and 870.

Norman Neff
Trenton State College
Hillwood Lakes
P.O. Box 940
Trenton, NJ 08625

Lost in Limbo

I assembled Mark Paxton's first utility, ("Lost in Basic"), from the January 1982 issue of *80 Microcomputing*. It executed in Level II, and in Disk Basic if I entered the subject program from the keyboard or from cassette. When I ran the utility against a program loaded from disk, Find went off into limbo. The following patch corrects this problem, allowing the utility to function correctly regardless of the program source. Change line 1140 to read 1140 CONT2 DEC HL. Add line 1145 PUSH HL.

You can further refine the two returns to Basic. The jumps to 1A19H, as published, pushes the stack pointer one address per execution of Find. With a large program in memory, repeated execution of Find results in an Out of Memory error. To correct this potential problem, change the jumps at lines 1130 and 2310 to JP 06CCH.

Michael R. Reed
2020 Victor Ave.
Lansing, MI 48910

How Many Colonies?

While playing "Space Empires" (*80 Microcomputing*, August 1981) my six-year-old son decided that since he did not have the required 90 megacredits to build a colony he would build only 0.1. The program responded with

"Number of Colonies Built: 1".

In examining the program I found that line 940 accepts your input of the number of colonies to build as B. Line 945 compares B with 0 and goes to line 1060 if they are equal. Line 964 compares B with E1 to see if there is a colony to be built.

Line 950 generates B1 and line 960 determines if you have enough credits. The problem arises because there is no comparison to check if you have paid the full 90 megacredits per colony. You can correct this by either checking the number of colonies (B) being requested or the amount of credits used. Add line 942 B = INT(B), this checks the number of colonies and also ensures the entire 90 megacredits are used instead of only a fraction.

Lawrence A. Crumb
3003 Marathon Drive
San Diego, CA 92123

Program Listing 2 was missing from Richard W. Castor's article "The Philatelist's Friend" in the December 1981 issue. Here it is:

```
90 CLEAR 2500:DEFSTRS,Y,D:DEFINTQ,R,C,P,L,E
95 DIMS1(120,13),L1(20),P$(20)
100 CLS: PRINT TAB(17)***** PHILATELIC INVENTORY *****:PRINT TAB
(24)***** EDITOR *****
101 GOT01220
102 'C$="UNITED STATES":Q=1:Y1="1880":Y2="1940":Y3="1978":S1="50
0":S2="900":R=3:T=336:D="700":S1(1,13)="14"
103 'S1(1,0)="550":FOR N=1 TO 4:LET S1(1,N)=RIGHT$(STR$(N),1):NE
XT N
104 'S1(2,0)="750":FORN=1TO9:LETS1(2,N)=RIGHT$(STR$(N),1):NEXTN:
FORN=10TO12:LETS1(2,N)=RIGHT$(STR$(N),2):NEXTN
105 CLS:PRINT TAB(25)***** MENU *****:PRINT
110 PRINT"TYPE (1) TO SEE AN EXISTING LISTING"
115 PRINT TAB(5)"(2) TO CORRECT/UPDATE EXISTING LISTING"
120 PRINT TAB(5)"(3) TO ADD TO INVENTORY"
125 PRINT TAB(5)"(4) FOR ANNUAL VALUE UPDATING"
130 PRINT TAB(5)"(5) TO SAVE UPDATED FILE"
135 PRINT TAB(5)"(6) TO END PROGRAM"
140 INPUT E:IFE>6GOT0105ELSEBONEGOTO200,1000,420,600,1120,1205
200 CLS:PRINT"SCOTT CATALOG NUMBER DESIRED";TAB(32);:INPUT B$
205 FOR R1=1 TO R
210 IFS1(R1,0)=B$THEN220
215 NEXT R1:PRINT"SCOTT CATALOG NUMBER-";B$;"-NOT IN FILE":GOTO
265
220 PRINT"USED SINGLES";TAB(25)S1(R1,1);TAB(32)"CATALOG VALUE";T
AB(50)S1(R1,2)
225 PRINT"MINT SINGLES";TAB(25)S1(R1,3);TAB(32)"CATALOG VALUE";T
AB(50)S1(R1,4)
230 IF VAL(B$)<VAL(D) GOTO 255
235 PRINT"MINT PLATE BLOCKS";TAB(25)S1(R1,5);TAB(32)"CATALOG VAL
UE";TAB(50)S1(R1,6)
240 PRINT"MINT SHEETS";TAB(25)S1(R1,7);TAB(32)"CATALOG VALUE";T
AB(50)S1(R1,8)
245 PRINT"FIRST DAY COVERS";TAB(25)S1(R1,9);TAB(32)"CATALOG VALU
E";TAB(50)S1(R1,10)
```

Program continues

From Computer Plus to YOU...

PLUS after PLUS after PLUS



Color Computer Disc Drive
\$470



32K Exp. Int. \$334



Line Printer VII \$315



Color Computer 4K \$310
w/16K Ext. Basic \$459
w/32K Ext. Basic \$525

NEW



**Model 16 128K
1 Drive** \$4299



Model III 16K \$839
Model III 48K
2 Disc & RS232C \$2059

BUY DIRECT Here are just a few of our fine offers...
call TOLL FREE for full information.

COMPUTERS

Model II 64K	\$3300
Model III 4K LEV I	599
MODEL III 16K	839
MODEL III 32K	945.50
*MODEL III 32K	881.50
MODEL III 48K	1052
*MODEL III 48K	924
Model III 48K	
2 Disc & RS232 c	2059
Color Computer 4K	310
Color Computer 16K	416.50
*Color Computer 16K	352.50
Color Computer 16K	
w/extended basic	459
Color Computer 32K	
w/extended basic	525
Color Computer Drive 0	470
Pocket Computer 2	230
VIDEOTEK	310

*Computer Plus New Equipment,
with NEC RAM installed.
180 Day Computer Plus Warranty.

PERIPHERALS

Expansion Interface OK	\$249
Expansion Interface 16K	355.50
*Expansion Interface 16K	291.50
Expansion Interface 32K	462
*Expansion Interface 32K	334
16K RAM N.E.C. 200 N.S. chips	25

MODEMS

Lynx Direct Connect MI/MIII	235
Auto Ans./Dial	
Telephone Interface II	169
R.S. Modem I D.C.	130
R.S. Modem II D.C.	210

PRINTERS

Daisy Wheel II	1695
Epson MX80	479
Epson MX80 FT	589
Epson MX100	759
Line Printer VII	315
Line Printer VIII	620
Line Printer V	1610

Microline 80	325
Microline 82A	465
Microline 83A	735
Microline 84 Parallel	1090
P. C. Plotter Printer	199

DISK DRIVES

R.S. Model III 1ST-Drive	712
Tandon 40 Track MI	299
R.S. 1 Drive Exp MII	999
R.S. 2 Drive Exp MII	1518
R.S. 3 Drive Exp MII	2040

SOFTWARE

R.S. Software 10% off list	
Newdos 80 MIII	149
ST80III	149

ETC.

Verbatim 5" Double Density	32
Verbatim 8" Data Life	49.95
Ctr-80A recorder	52
C. C Joysticks	22

**We have the lowest possible
Fully Warranted Prices AND
a full complement of Radio Shack
Software.**

DEALER INQUIRIES ARE INVITED

Prices subject to change without notice.
Not responsible for typographical errors.
TRS-80 is a registered trademark of Tandy Corp.



call TOLL FREE 1-800-343-8124

computer plus

245A Great Road
Littleton, MA 01460
617-486-3193

Write for your
free catalog

18

SOFTWARE

COMPUTER PRODUCTS

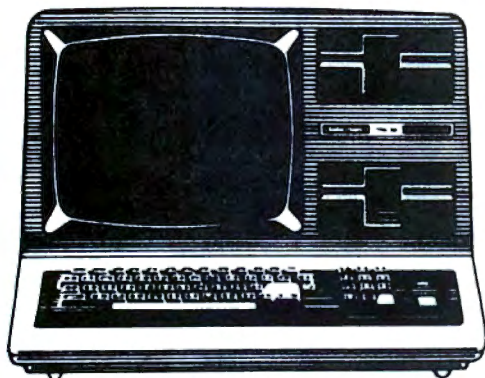

■ GAMES GAMES GAMES ■

The computer was not meant to be ALL business! We carry a complete stock of Adventure & Arcade style games. Each game has been subjected to extensive testing by one of our less productive staff members. (* denotes rated great!)

For Model I or III

*Adventures by Scott A.....	Cass.	\$19.95
1-12 order by adventure number - also for Atari & Apple		
	Cassette	Disk
Super Nova.....	15.95	19.95
*Galaxy Invasion.....	15.95	19.95
*Cosmic Fighter.....	15.95	19.95
*Robot Attack.....	15.95	19.95
*Attack Force.....	15.95	19.95
*Defense Command.....	15.95	19.95
*Alien Defense.....	19.95	19.95
Star Trek 3.5.....	14.95	19.95
Sky Warrior.....	14.95	19.95
*Eliminator.....	14.95	20.95
*Armor Patrol.....	19.95	24.95
*Valkyrie.....	29.95	39.95
Planetoids.....	19.95	20.95
Interlude.....	18.95	21.95

For Kiddies

Human Adventure.....	—	19.95
*Old McDonald.....	19.95	—
Frog.....	14.95	—
Red Riding Hood.....	14.95	—

Color Computer

	CART	CASS.	DISK
*Beserk.....	—	24.95	—
*Cave Hunter.....	—	24.95	—
Calixto Island.....	—	19.95	—
Black Sanctum.....	—	19.95	—
*Star Blasters.....	39.95	—	—
Color Meteroids.....	—	21.95	—
Magic Cubes.....	—	19.95	24.95
*Pac Attack.....	—	24.95	29.95
Hangman.....	—	14.95	—
Sigmon.....	—	29.00	—
Secs.....	—	29.00	—
Color Forth.....	109.95	—	—
3D Drawing.....	—	24.95	—
Minotaur Adventure.....	—	19.95	—
Color Scripsit.....	38.95	—	—
*Art Gallery.....	39.95	—	—
*Learning Lab.....	—	49.95	—

■ SPECIAL DELIVERY ■

By now you have heard of this
FANTASTIC SOFTWARE.
Now experience it!

- Maintain Your Mail List
- Print Free Format Labels
- Merge with Form Letters
- Fast Fast Fast Machine Language
- Sorts Faster Than A Speeding Bullet
- Enter Names at typist speeds
- Use with Scripsit, Lazywriter, Electric Pencil (We sell them all!)
- Extract Selected Names
- Boldface & Underline (Even on the Daisy Wheel III!)
- Get your Form Letters Past the Secretary's Desk!

XTRA Special Delivery Includes All Of The Above PLUS:

- Disk Sorts
- Multi Label Printer
- Key Definitions

The last mailing list you will ever have to buy!

NOTE TO REGISTERED OWNERS

Registered SPECIAL DELIVERY owners can upgrade to XTRA! by returning their ORIGINAL disk with \$74.00 + \$2.00 shipping and handling.

FOR YOUR MODEL I OR III:

(requires minimum of 32K, single drive)

SPECIAL DELIVERY.....	\$125
XTRA SPECIAL DELIVERY.....	\$199

FOR YOUR MODEL II:

(requires TRSDOS version 2.0 & Scripsit 2.0)

SPECIAL DELIVERY.....	\$199
-----------------------	-------

■ OTHER FINE SOFTWARE ■

■ FOR THE MODEL I & III ■

All New Electric Pencil

**We are through stalling.
It's really here!**

The original PENCIL set a standard for ease of use that no other editors can match. The NEW ELECTRIC PENCIL reaches even greater heights with many exciting new features that make it the most simple to learn text editor available for the TRS-80 Mod I or III! Don't leave home without it.
Electric Pencil version 2.....\$84.95

CONCEPTS

FOR HOME AND BUSINESS

EDAS

This is the assembler from MisoSys which is used for all assemblies of Special Delivery. We had real headaches until this came along. A must for any assembly language programmer.

EDAS MOD I/MOD III\$75.00

THE DISASSEMBLER

This is simply the most advanced disassembler we have ever seen. Creates EDAS source code, inserts user-defined labels, disassemble disk or memory, generates ORGS & EQUates.

THE Disassembler - Mod I, III\$39.00

RETAIL INVENTORY CONTROL SYSTEM

Maintains Inventory, Tracks Stock Sold, Tracks Backorders, Tracks Reorder Items, Prints Purchase Orders, Prints Listings by Vendors, & MUCH MORE!

This is the one we use in our store.

Retail Inventory - Mod I, III\$129.00

MAXI MANAGER

A real database manager has finally come to the Model I & III.

Maxi\$89.95

MORE

VISICALC MODEL I\$94.95

VISICALC MODEL III\$189.00

SCRIPSIIT\$94.95

R.S. General Ledger\$94.95

LAZYWRITER I/III\$165.00

NEWDOS 80 2.0\$145.00

LDOS\$125.00

ST80 III\$145.00

Super Utility Plus\$74.95

Quick Fix\$29.95

NEW NEW NEW...

ELECTRA SKETCH 29⁹⁵

PRINTERS

EPSON PRINTERS

Epson has become the standard by which other low-cost printers are measured. *Highly recommended!*

MX80\$465.00

MX80 F/T\$635.00

MX70\$299.00

MX100\$745.00

Printer Cable\$35.00

TRS80 Bus Board/Cable\$100.00

GRAPHTAX 80\$80.00

MX-80 Ribbons\$14.00

Print Heads\$38.00

2K Serial Card\$145.00

QUME DAISY WHEEL PRINTERS

Sprint 9 KSR 35cps\$1995.00

Sprint 9 RO 35cps\$1895.00

Sprint 9 LTD 45cps\$2195.00

Tractor Feed\$195.00

NEC SPINWRITERS

NEC 7730 RO Parallel\$2650.00

NEC 7720 KSR\$3100.00

DATA SEPARATOR

The lifesaver. If you have a MOD I with disk drives and no data separator you have problems. Order from us or someone else but get a data separator.

Data Separator\$29.95

DOUBLER

Another breakthrough. Add double density to your MOD I. Includes built in data separator.

Doubler\$165.95

GREEN SCREENS

Not much difference between green screens but everybody should have one. If you don't buy ours, buy theirs.

MOD I/MOD III\$17.95

MOD II/LEEDIX 100\$22.95

IJG BOOKS

Disk Mysteries\$21.50

BASIC Faster & Better\$28.95

BASIC Decoded\$28.95

DISKETTES

VERBATIM DATALIFE! Re-inforced hub, double density, single sided.

Pkg. of 10 - 5 1/4 inch\$25.00

ELEPHANT DISKS. Re-inforced hub, double density, single sided.

Pkg. of 10 - 5 1/4 inch\$24.00

MX80 PRINTER STANDS

Smoked plastic printer stand. Hope you buy one of these — gotta bunch of these suckers in stock.\$23.95

OTHER GOODIES

Flip Sort Boxes 5 1/4"\$28.95

Flip Sort Boxes 8"\$39.95

Plastic File Boxes (Holds 10 Disks) 4 Color's . . \$3.50

Verbatim Head Cleaner Kit\$11.50

Orchestra 90\$145.00

Orchestra 85\$125.00

Add 3% Shipping & Handling

Texas Residents add 5% Sales Tax on all hardware items

Specify whether MOD I, II, or III when ordering.

SOFTWARE CONCEPTS

(214) 458-0330

(214) 458-0411

visit our new retail store at
116 Preston Valley
Shopping Center
Dallas, Texas

Dealer inquiries invited.

80 DEBUg

Program continued

```

250 PRINT"SPECIAL SITUATIONS";TAB(25)S1(R1,11);TAB(32)"CATALOG V
ALUE";TAB(50)S1(R1,12):GOTO 260
255 GOSUB1300:PRINT:PRINTTAB(32)"TOTAL VALUE";TAB(50)S1(R1,13):G
OTO265
260 GOSUB1305:PRINTTAB(32)"TOTAL VALUE";TAB(49)S1(R1,13)
265 PRINT:INPUT"ANOTHER INDIVIDUAL LISTING? YES OR NO";A$
270 IF A$="YES" THEN GOTO 200 ELSE CLS:GOTO 105
420 PRINT:PRINT TAB(14)"**** FILE #";Q;"-INPUT ROUTINE ****"
425 PRINT"TO END INVENTORY, ENTER THE SCOTT CATALOG NUMBER ";S2;
" FOR END OF FILE"
430 IF VAL(S1)<VAL(D) THEN PRINT"INVENTORY WILL INCLUDE ONLY USE
D AND MINT SPECIMENS";PRINT"FOR SCOTT CATALOG NUMBERS LESS THAN
--";D
431 R=R:PRINT
500 PRINT "SCOTT CATALOG NUMBER";TAB(32);:INPUT S1(R,0)
501 IFS1(R,0)=S2THENCLS:GOTO105
502 IF VAL(S1(R,0))<VAL(S1)ORVAL(S1(R,0))>VAL(S2) THEN PRINT"NOT
IN THIS INVENTORY";INPUT "HIT ENTER TO CONTINUE";X:GOTO 500
505 PRINT "NUMBER OF USED COPIES";TAB(32);:INPUT S1(R,1)
510 PRINT "AT CATALOG VALUE OF";TAB(32);:INPUT S1(R,2)
515 PRINT "NUMBER OF MINT COPIES";TAB(32);:INPUT S1(R,3)
520 PRINT "AT CATALOG VALUE OF";TAB(32);:INPUT S1(R,4)
525 IFFVAL(S1(R,0))<VAL(D)THENR1=R:GOSUB1300:R=R1:PRINT"TOTAL CAT
ALOG VALUE ABOVE";TAB(32)S1(R,13):T=T+VAL(S1(R,13))
530 IFFVAL(S1(R,0))<VAL(D)THENR=R+1:GOTO500
535 PRINT "NUMBER OF MINT PLATE BLOCKS";TAB(32);:INPUT S1(R,5)
540 PRINT "AT CATALOG VALUE OF";TAB(32);:INPUT S1(R,6)
545 PRINT "NUMBER OF MINT SHEETS";TAB(32);:INPUT S1(R,7)
550 PRINT "AT CATALOG VALUE OF";TAB(32);:INPUT S1(R,8)
555 PRINT "NUMBER OF FIRST DAY COVERS";TAB(32);:INPUT S1(R,9)
560 PRINT "AT CATALOG VALUE OF";TAB(32);:INPUT S1(R,10)
565 PRINT "SPECIAL SITUATIONS";TAB(32);:INPUT S1(R,11)
570 PRINT "AT CATALOG VALUE OF";TAB(32);:INPUT S1(R,12)
575 R1=R:GOSUB1305:R=R1:PRINT"TOTAL CATALOG VALUE";TAB(32)S1(R,1
3):T=T+VAL(S1(R,13))
580 R=R+1
581 IFR>120THENPRINT"FILE FULL":GOTO105
582 GOTO500
600 PRINT TAB(17)"**** ANNUAL VALUE UPDATE ****"
605 INPUT"PRICING IS BASED UPON CATALOG VALUES FOR YEAR--";Y3:PR
INT
610 CLS:PRINT"TYPE (2) FOR USED SINGLES";TAB(32)"(4) FOR MINT SI
NGLES"
615 PRINT TAB(5)"(6) FOR MINT PLATE BLOCKS";TAB(32)"(8) FOR MINT
SHEETS"
620 PRINT TAB(4)"(10) FOR FIRST DAY COVERS";TAB(31)"(12) FOR SPE
CIAL SITUATIONS"
625 INPUT C:IF C=1 OR C=3 OR C=5 OR C=7 OR C=9 OR C=11 THEN GOTO
610
630 IF C=2 PRINT"USED SINGLES PRICE UPDATE":GOTO 640
631 IF C=4 PRINT"MINT SINGLES PRICE UPDATE":GOTO 640
632 IF C=6 PRINT"MINT PLATE BLOCK PRICE UPDATE":GOTO 665
633 IF C=8 PRINT"MINT SHEET PRICE UPDATE":GOTO 665
634 IF C=10 PRINT"FIRST DAY COVER PRICE UPDATE":GOTO 665
635 IF C=12 PRINT"SPECIAL SITUATION PRICE UPDATE":GOTO 665
640 FOR R1=1 TO R
641 IFS1(R1,0)=S2THENPRINT"END OF INVENTORY":INPUT"HIT ENTER TO
CONTINUE";X:CLS:GOTO655
645 PRINT"SCOTT CATALOG NUMBER";TAB(25)S1(R1,0);TAB(32)"NEW VALU
E";TAB(50);:INPUT S1(R1,C)
650 NEXT R1
655 INPUT"ANOTHER PRICE UPDATE? YES OR NO";A$
660 IF A$="YES" THEN GOTO 610 ELSE GOTO 699
665 FOR R1=1 TO R
670 IF(VAL(S1(R1,0))=VAL(D)ANDS1(R1,0)>D)ORS1(R1,0)=DORVAL(S1(R1
,0))>VAL(D)THENGOTO680
675 NEXT R1
680 FOR R2=R1 TO R
681 IF VAL(S1(R2,0))<VAL(D) THEN R1=R2:GOTO 670
682 IFS1(R2,0)=S2THENGOTO690
685 PRINT"SCOTT CATALOG NUMBER";TAB(25)S1(R2,0);TAB(32)"NEW VALU
E";TAB(50);:INPUT S1(R2,C)

```

Program continues

Continued from page 24

ple ever need, the comment leaves a negative impression with the reader.

• "There are several programs, most of them are written in Basic...", and later, to drive the stake home, "Though the program is in Basic..." Now, that's really great! There are over 4,000 Z80 machine language instructions in Newscrip, and about 800 lines of Basic code in the two main programs that do disk I/O and setup of tables for the 20 distinctly different printers we fully support. To me, that sounds like a sophisticated machine-language program with some Basic programs acting as front-ends. The reviewer marvels that we never lose keystrokes even though we are in Basic, but doesn't seem to realize that nothing written in Basic could be one tenth as fast as Newscrip. Unfortunately, readers have long since been warned that nothing in Basic is worth buying, so combined with a manual that doesn't let them look anything up, they are by now convinced that Newscrip is not for them. This is untrue, of course. We use Basic to make it easy to add tables for new printers, and to avoid the incompatibilities among the operating systems. The single version of Newscrip a customer buys will run on all the operating systems and can even be moved between Model I and III! That's a big reason for retaining some Basic. But none of that is explained in this review.

• "The program... does not provide any means of hyphenating." At the time the review was written, that was true, but the current release of Newscrip supports both hard hyphens and ghost hyphens. The error here is one of obsolescence and lack of communication, and could have been avoided by reading the letter of response I sent the author last November. Unfortunately, that letter seems to have been ignored, and since the reviewer has an unlisted phone number, it was impossible for me to set the record straight.

In fairness to the author of the review, he also made many favorable comments and on balance seemed to like Newscrip very much. Based on correspondence with him (prior to his writing this article), I believe he is well satisfied with Newscrip and with the support he has received from Prosoft. Feedback and suggestions from our customers and reviewers have been heeded, and Newscrip 7.0 contains a number of performance, functional and ease-of-use enhancements that were inspired by such people and offered to existing customers for very modest fees. I'll be glad to make a copy of 7.0 available to one of your reviewers so that a timely and

Continued on page 32

TRS-CP/M*

TRS-80 owners . . . the Mapper I and III Works Packages are available in 64K versions for \$599.

OMIKRON proudly presents

The Works

The ultimate CP/M package for your TRS-80* Model I or III

The WORKS includes:
Mapper I & CP/M 2.2, CBASIC II, MBASIC-80
and WordStar

\$399

Mapper I and **Mapper III** cards are designed for simple plug in installation.

CP/M 2.2 is the latest version of CP/M from Digital Research. Our package also includes the MAPPER I CP/M adapter and a sophisticated set of utilities and drivers designed to optimize the CP/M system for the TRS-80.

List price: \$239

WordStar is widely recognized as the most advanced product on the market. It is featured by many computer manufacturers, including Xerox, for wordprocessing applications.

List price: \$495

MBASIC-80 is the CP/M version of Microsoft BASIC. The conversion of TRS-DOS BASIC programs to MBASIC is easy because the syntax is almost identical.

List price: \$349

CBASIC II is the most widely used BASIC for CP/M applications programs. This version of BASIC contains all of the features necessary to develop complex business programs.

List price: \$149

"See Review 80 Microcomputing, April 1982, page 370"

OMIKRON Products that set Precedents
1127 Hearst Street, Berkeley, CA 94702 (415) 845-8013

80 DEBUG

Program continued

```

690 IF R2=R PRINT"END OF INVENTORY":INPUT"HIT ENTER TO CONTINUE"
;X:CLS:GOTO 655
695 NEXT R2
699 FOR R1=1 TO R
700 IF VAL(S1(R1,0)) < VAL(D) THEN GOSUB1300
705 IF (VAL(S1(R1,0)) = VAL(D) AND S1(R1,0) > D) OR S1(R1,0) = DORVAL(S1(R1,0)) > VAL(D) THEN GOSUB1305
706 NEXT R1
710 T=0
715 FOR R1=1 TO R
720 T=T+VAL(S1(R1,13))
725 NEXT R1:IF E<>5 THEN GOTO 105 ELSE GOTO 1120
1000 CLS
1005 PRINT TAB(18)"**** EDIT DATA ROUTINE ****"
1010 PRINT:PRINT"COLUMN NUMBERS HAVE BEEN ASSIGNED AS FOLLOWS"
1015 PRINT:PRINT"USED SINGLES";TAB(25)"1";TAB(32)"CATALOG VALUE";TAB(50)"2"
1020 PRINT"MINT SINGLES";TAB(25)"3";TAB(32)"CATALOG VALUE";TAB(50)"4"
1025 PRINT"MINT PLATE BLOCKS";TAB(25)"5";TAB(32)"CATALOG VALUE";TAB(50)"6"
1030 PRINT"MINT SHEETS";TAB(25)"7";TAB(32)"CATALOG VALUE";TAB(50)"8"
1035 PRINT"FIRST DAY COVERS";TAB(25)"9";TAB(32)"CATALOG VALUE";TAB(49)"10"
1040 PRINT"SPECIAL SITUATIONS";TAB(24)"11";TAB(32)"CATALOG VALUE";TAB(49)"12"
1045 PRINT:PRINT"SCOTT CATALOG NUMBER AND COLUMN OF ENTRY":INPUT"TO BE CORRECTED";B$,C:PRINT
1050 FOR R1=1 TO R
1055 IF S1(R1,0) = BSGOTO1065
1060 NEXT R1:PRINT"SCOTT CATALOG NUMBER--";B$;"--NOT IN FILE":GOTO 1085
1065 PRINT"DATA NOW READS--";S1(R1,C)
1070 PRINT:INPUT"ENTER CORRECT DATA--";S1(R1,C)
1075 IF VAL(B$) < VAL(D) THEN GOSUB1300
1080 IF (VAL(B$) = VAL(D) AND B$ > D) OR B$ = DORVAL(B$) > VAL(D) THEN GOSUB1305
1085 INPUT"HAVE ALL CORRECTIONS BEEN MADE? YES OR NO";A$
1090 IF A$="YES" THEN CLS:GOTO 1100
1095 IF A$="NO" THEN CLS:GOTO 1010
1100 T=0
1105 FOR R1=1 TO R
1106 PRINTR1,VAL(S1(R1,13))
1110 T=T+VAL(S1(R1,13))
1115 NEXT R1:IFE<4 THEN GOTO 105
1120 C=0:R1=1:P=1:K1=0:P$(P)="":CLS:PRINT"BE PATIENT--I'M WORKING"
1121 LETV=VAL(S1(R1,C))
1122 IFR1=R THEN PRINT"FORMATTING COMPLETE":L1(P)=K1:GOTO1150
1124 L=LEN(S1(R1,C)):L$=RIGHT$(STR$(L),1)
1126 IFS1(R1,C)="" OR LEN(S1(R1,C)) = 0 OR VAL(S1(R1,C)) = 0 THEN L$="1":L=L+1:S1(R1,C)=""
1128 S1(R1,C)=L$+S1(R1,C):L$=""
1130 K1=K1+(L+1)
1132 IF 248-K1 < L+1 THEN L1(P)=K1-(L+1):K1=L+1:P=P+1:P$(P)=" "
1134 P$(P)=P$(P)+S1(R1,C)
1141 IFC=4 AND V(VAL(D) THEN S1(R1,C)="" :C=13:GOTO1124
1142 S1(R1,C)="" :C=C+1
1146 IFC=14 THEN R1=R+1:C=0:GOTO1121
1148 GOTO1124
1150 GOSUB1315
1156 PRINT:PRINT"NOTE LOCATION AT WHICH THIS FILE IS TO START":INPUT"PLACE CASSETTE IN <RECORD> MODE. WHEN READY, PRESS <ENTER>"
;X:CLS
1158 PRINT#-1,C$,Q,Y1,Y2,Y3,S1,S2,R,T,D,P
1160 FOR P1=1 TO P
1162 PRINTP1:L1(P1);P$(P1)
1164 PRINT#-1,L1(P1),P$(P1)
1166 INPUT"PRESS <ENTER> TO CONTINUE";X:CLS
1168 NEXT P1:CLS

```

Program continues

Continued from page 30

accurate description of our product can be presented to your readers in the near future.

Chuck Tesler
Prosoft
North Hollywood, CA

Yes, we have erred. The *Newsprint* review we ran in March was on an older version. We, too, believe the reviewer liked the program, but misstated some facts. We offer our sincere apologies to Prosoft.

A review of *Newsprint* 6.2 will appear in the May issue of our sister publication, *Microcomputing*. The reviewer, Bruce Powell Douglass, has long been a critic of poor documentation. Yet he claims the *Newsprint* documentation is the best he has seen and recommends that other companies use it as a model. He also points out that there is little, if any, loss of execution speed due to the portions of Basic code in *Newsprint*, and this is hardly a point of concern. Douglass and our reviewer in March recommend the program.—Eds.

Mod II Compiler Basic Revisited

I wish to comment on Larry Clark's article on Model II Compiler Basic (*80 Microcomputing*, February 1982). The review is unnecessarily harsh. Unlike Mr. Clark, I use Compiler Basic extensively. I believe Compiler Basic is preferable to Microsoft Basic for the development of large programs for the Model II. Mr. Clark makes much of memory limitations of Compiler Basic. The limitations apply only when the development system is used in its quasi-interpreter mode. In this mode, source code, object code and RSBASIC are all in memory, together with TRSDOS. Therefore, you cannot develop large programs with the quasi-interpreter command Run.

You can develop large programs using the Compile command, however. Approximately 15K of source program can be held in memory at the same time as RSBASIC. This is the limitation for using the automatic Renumber command for all of any one source file. However, source files can be divided in convenient pieces and independently renumbered in RSBASIC, and then later joined back together in one very large source file using BEdit. The overall limitation on object program size that can reside in memory at run time is

Continued on page 34

FORTRESS

Only the Fast Survive!



SSM SOFT SECTOR MARKETING,
INCORPORATED

6250 Middlebelt • Garden City, MI 48135 • 800-521-6504/(313) 425-4020

Written by Larry Ashmun

Copyright © 1982 Soft Sector Marketing, Inc.

Prices per Game: TRS-80 16K Level II Mod I/Mod III Cassette \$15.95

TRS-80 32K Level II Mod I/Mod III Diskette \$19.95

10% discount for 2 items, 15% for 3 or more. Please add \$2.50 per order for postage & handling. Michigan residents add 4% sales tax. Outside USA (except Canada) please add \$10.00 per order for postage & handling.

Sound effects are playable through the cassette AUX plug. High scores are automatically saved after each game on disk versions.

Call or write for our complete catalog.



Continued from page 32

34,320 bytes.

I market Estate Planning Model, an estate tax planning decision support system. This program has 51,982 bytes of source code, divided into three modules which chain back and forth. I originally wrote this program in Microsoft Basic, but I later converted it to Compiler Basic. I use both languages extensively and prefer RSBASIC for the development of large programs.

RSBASIC offers the following advantages:

- Much better security of source code.
- True subroutines. All subroutines

must be compiled with the main program at the same time, but I do not find that onerous.

- The ability to read the screen directly. Somehow this function was omitted from Model II Microsoft Basic, but it is included in RSBASIC and greatly simplifies using formatted I/O screens.
- Program chaining.
- Source program lines can be copied from one portion of a source file to another portion of a source file, with automatic renumbering.

Ralph A. Beard
Canfield, OH

Mod II Scripsit Inferior

The review of Model II Scripsit (*80 Microcomputing*, February 1982) was informative and accurate, but it failed to adequately contrast that word processing system with systems available for Models I and III. In my job I use Model II Scripsit and at home I use Model I Scripsit (usually enhanced by either SuperScript or Qwerty). Model II Scripsit is generally much inferior in speed and ease of use.

Model II Scripsit has almost none of the features of Model I Scripsit and it is much less "user friendly." The only feature of Model II Scripsit that represents an advance over Model I Scripsit is the "User Defined Keys" feature.

The Model II has been touted as a professional level computer. Anyone who uses word processing on a professional level, as I do, will find that the Model II is less professional than the Model I. Readers who want to get into word processing should visit a Radio Shack computer center and take along a stop watch. They should type a 600 word document with both a Model II and a Model III computer, using the respective Scripsit programs, and time the operation. Then they should make some major changes—such as switching paragraphs around—and time them. When they have a satisfactory final version, they should make a backup copy on another disk and time that operation. I predict that they will find the Model II Scripsit to be less than half as fast as the Model III Scripsit and much clumsier to use. Surely any review of a word processing program ought to take such matters into account.

Philip F. Jackisch
Royal Oak, MI

80 DEBUG

Program continued

```

1170 PRINT"RECORDING COMPLETE. NOTE TAPE LOCATION"
1174 PRINT:INPUT"HAVE YOU RECORDED THIS FILE TWICE. (Y/N)";A$:CL
S
1176 IFA$="Y"THENGOTO1178ELSEGOTO1150
1178 GOTO105
1205 INPUT"HAVE YOU RECORDED THIS FILE TWICE? YES OR NO";A$:CLS
1210 IFA$="YES"THENGOTO1215ELSEGOTO105
1215 PRINT"TO EDIT, ADD TO, OR REVIEW THIS INVENTORY, RUN PROGRA
M LEVEL B":END
1220 PRINT"INSERT DESIRED FILE. PLACE CASSETE IN PLAY MODE AT PR
OPER":INPUT"LOCATION. WHEN READY, HIT ENTER";X:CLS:PRINT"DATA FI
LES LOADING"
1222 INPUT0-1,C$,Q,Y1,Y2,Y3,S1,S2,R,T,D,P
1224 GOSUB1315
1230 FORP1=1TOP
1232 INPUT0-1,LL(P1),P$(P1)
1234 PRINTLL(P1);P$(P1)
1236 NEXTP1
1238 CLS:PRINT"RETRIEVAL COMPLETE":INPUT"PRESS <ENTER> TO CONTIN
UE";X:CLS:PRINT"MATRIX RESTORATION IN PROCESS"
1240 P1=1:R1=1:C=0:K1=1
1242 S1(R1,C)=MID$(P$(P1),(K1+1),VAL(MID$(P$(P1),K1,1))):IFC=0TH
ENV=VAL(S1(R1,C))
1243 'PRINTK1;P1;R1;C;S1(R1,C):INPUT"PRESS <ENTER> TO CONTINUE";
X:CLS
1244 K1=K1+1+VAL(MID$(P$(P1),F1,1)):IFK1=>LL(P1)THENP$(P1)="":P1
=P1+1:K1=1
1246 IFR1=RTHEN GOTO1258
1248 IFS1(R1,C)="*":THENS1(R1,C)="0"
1250 IFC=4 AND V<VAL(D)THENC=13:GOTO1242
1252 C=C+1
1254 IFC=14THENR1=R1+1:C=0:GOTO1242
1256 GOTO1242
1258 PRINT"MATRIX RESTORATION COMPLETE":PRINT:INPUT"TO SEE THE M
ENU, PRESS <ENTER>";X:CLS:GOTO105
1300 S1(R1,13)=STR$(VAL(S1(R1,1)))*VAL(S1(R1,2))+VAL(S1(R1,3))*VA
L(S1(R1,4)):S1(R1,13)=RIGHT$(S1(R1,13),LEN(S1(R1,13))-1):RETURN
1305 S1(R1,13)=STR$(VAL(S1(R1,1)))*VAL(S1(R1,2))+VAL(S1(R1,3))*VA
L(S1(R1,4))+VAL(S1(R1,5))*VAL(S1(R1,6))+VAL(S1(R1,7))*VAL(S1(R1,
8))+VAL(S1(R1,9))*VAL(S1(R1,10))+VAL(S1(R1,11))*VAL(S1(R1,12))
1310 S1(R1,13)=RIGHT$(S1(R1,13),LEN(S1(R1,13))-1):RETURN
1315 PRINT"COUNTRY "C$" FILE"Q" CONSISTS OF "R-1" RECORDS":PRI
NT"HAVING A TOTAL VALUE OF $"T:PRINT"FILE INCLUDES SPECIMENS ISS
UED FROM "Y1" THROUGH "Y2:PRINT"AND IS BASED UPON "Y3" CATALOG V
ALUES"
1320 PRINT:PRINT"FILE INCLUDES SCOTT CATALOG #"S1" THROUGH #"S2:
PRINT"WITH A FULL INVENTORY #"D" AND ABOVE"
1325 PRINT"THESE ARE "P" PRINT STATEMENTS":PRINT"THESE ARE "120-
(R-1)" ENTRIES REMAINING":RETURN

```

NEWDOS80 Corrections

We at Apparat wish to thank Paul Prescott and *80 Microcomputing* for an excellent article on our NEWDOS80 Version 2.0 released in August 1981. We offer the following corrections: The NEWDOS80 Version 2.0 for the Model I is sold separate from that for the Model III and vice versa; MINI-DOS does not support chaining; regular DOS and DOS-CALL do; CBF is format six of Copy and was available in a more limited extent in Version 1.0; Basic has only four new overlays, not eight; and the full-disk-copy-to-apply-zaps service is \$10.

Software Technical Support
Apparat Inc.
Denver, CO

Yes, I want your special offer

 10 Vol. Hardcover \$164.00 EN8100 10 Vol. Softcover \$83.00 EN8080 (UPS shipping included)

ENCYCLOPEDIA HARDCOVER Single Volumes \$19.95 each *

 Vol. 1 Vol. 2 Vol. 3 Vol. 4 Vol. 5 Vol. 6 Vol. 7 Vol. 8 Vol. 9 Vol. 10
EN8101 EN8102 EN8103 EN8104 EN8105 EN8106 EN8107 EN8108 EN8109 EN8110

ENCYCLOPEDIA SOFTCOVER Single Volumes \$10.95 each *

 Vol. 1 Vol. 2 Vol. 3 Vol. 4 Vol. 5 Vol. 6 Vol. 7 Vol. 8 Vol. 9 Vol. 10
EN8081 EN8082 EN8083 EN8084 EN8085 EN8086 EN8087 EN8088 EN8089 EN8090

ENCYCLOPEDIA LOADER Single Volumes \$14.95 each *

 Vol. 1 Vol. 2 Vol. 3 Vol. 4 Vol. 5 Vol. 6 Vol. 7 Vol. 8 Vol. 9 Vol. 10
EN8001 EN8002 EN8003 EN8004 EN8005 EN8006 EN8007 EN8008 EN8009 EN8010

Payment enclosed Visa MC Amex

Card # _____ MC Interbank _____

Signature _____ Expiration date _____

Name _____

Address _____

City _____ State _____ Zip _____

*Shipping and Handling:
\$1.50 per item U.S. and Canada. \$10.00 per item overseas airmail. Books shipped UPS with full street address.

8005

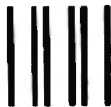

NO POSTAGE
NECESSARY
IF MAILED
IN THE
UNITED STATES

BUSINESS REPLY CARD

FIRST CLASS PERMIT NO. 80 PETERBOROUGH, NH 03458

POSTAGE WILL BE PAID BY ADDRESSEE

**WAYNE GREEN BOOKS
SALES DEPARTMENT
PINE STREET
PETERBOROUGH, NH 03458**



Maximize the potential of your TRS-80*

Encyclopedia for the TRS-80*

What's the key to getting the most from your TRS-80? No, it isn't the disk drives or printers or joysticks. It's information. Without a continual supply of information and ideas, you cannot realize the full potential of the TRS-80.

Our response to the clamor for additional information is the **Encyclopedia for the TRS-80**, a ten-volume reference work of programs and articles carefully selected to help you make the most of your microcomputer. You can consider the volumes of the **Encyclopedia** to be an extension of the documentation that came with your TRS-80. Each book is full of material on programming techniques, business, hardware, games, tutorials, education, utilities and interfacing.

Unlike conventional encyclopedias, the **Encyclopedia for the TRS-80** will never become stale or out of date. That's because the volumes of the **Encyclopedia** are being issued one-at-a-time, approximately six weeks apart. This means that each new volume will reflect the latest developments and discoveries, making this a living encyclopedia for TRS-80 users.

Volumes 1-7 available now.
Complete set available July 1982.
ENCYCLOPEDIA FOR THE TRS-80
\$19.95/volume HARDCOVER
\$10.95/volume SOFTCOVER

Encyclopedia Loader

The editors at Wayne Green Books want to help you use the programs in your **Encyclopedia for the TRS-80**. So to help you maximize the use of your microcomputing time, we created **Encyclopedia Loader™**.

By a special arrangement with Instant Software™, W G

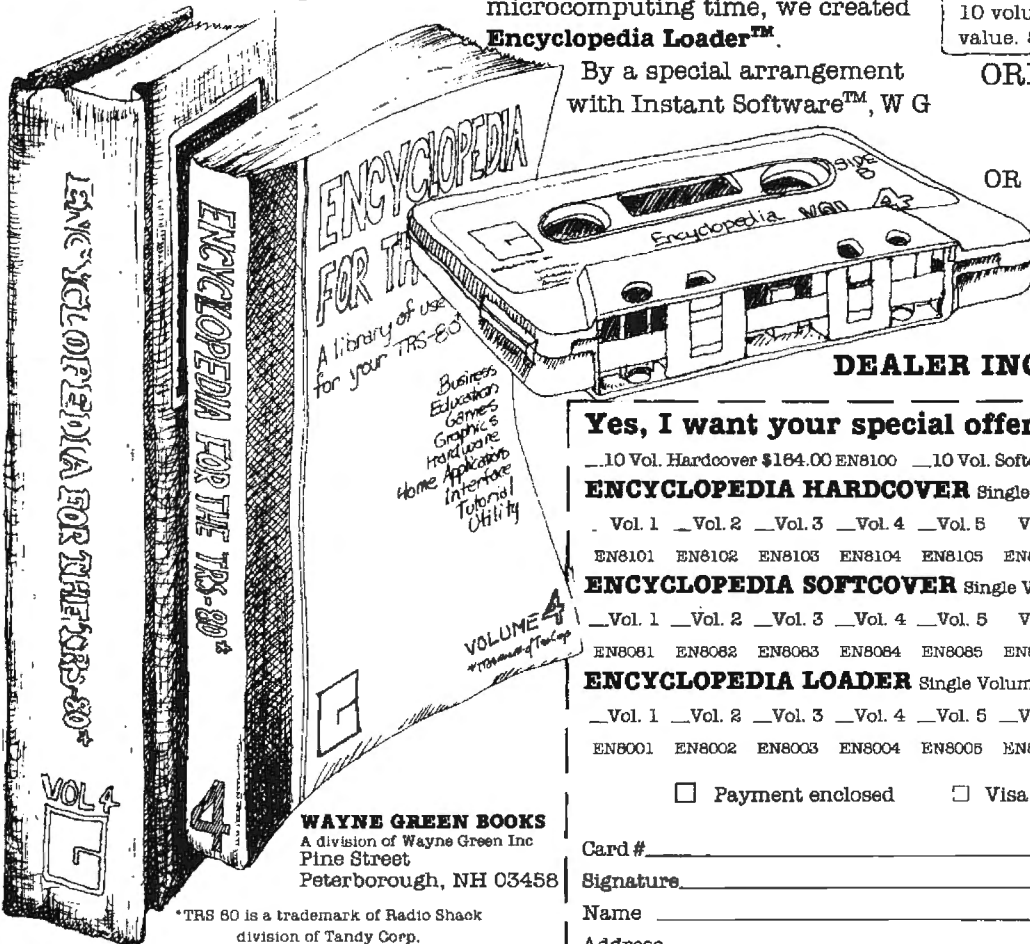

WAYNE GREEN BOOKS
A Division of Wayne Green Inc
Pine Street
Peterborough, NH 03458

*TRS 80 is a trademark of Radio Shack division of Tandy Corp.

The Encyclopedia for the TRS-80 is a Wayne Green publication.

Encyclopedia Loader is manufactured by Instant Software, a division of Wayne Green Inc.

FREE VOLUME see details below

Books can now provide you with selected programs contained in each volume of the **Encyclopedia for the TRS-80** on a special series of cassettes called **Encyclopedia Loader™**. Your encyclopedia provides the essential documentation but now you'll be able to load the programs instantly.

With **Encyclopedia Loader™** you'll save hours of keyboard time and eliminate the aggravating search for typos.
ENCYCLOPEDIA LOADER™

\$14.95/cassette

Receive one volume FREE

If you order the entire 10 vol. set of the **Encyclopedia for the TRS-80**, you'll receive the 10th vol. FREE!
10 Volume deluxe hard cover **COLLECTOR'S EDITION**—a \$199.50 value.
\$164.00 EN8100 postpaid.
10 volume soft cover edition, a \$109.50 value. \$83.00 EN8080 postpaid.

ORDERING INFORMATION

TOLL FREE CALL

1-800-258-5473

OR mail a copy of this form or card provided to:

WAYNE GREEN BOOKS
SALES DEPT.
PINE STREET
PETERBOROUGH NH 03458

DEALER INQUIRIES INVITED

Yes, I want your special offer

__10 Vol. Hardcover \$164.00 EN8100 __10 Vol. Softcover \$83.00 EN8080 (UPS shipping included)

ENCYCLOPEDIA HARDCOVER Single Volume \$19.95 each*

__Vol. 1 __Vol. 2 __Vol. 3 __Vol. 4 __Vol. 5 __Vol. 6 __Vol. 7 __Vol. 8 __Vol. 9 __Vol. 10
EN8101 EN8102 EN8103 EN8104 EN8105 EN8106 EN8107 EN8108 EN8109 EN8110

ENCYCLOPEDIA SOFTCOVER Single Volumes \$10.95 each*

__Vol. 1 __Vol. 2 __Vol. 3 __Vol. 4 __Vol. 5 __Vol. 6 __Vol. 7 __Vol. 8 __Vol. 9 __Vol. 10
EN8081 EN8082 EN8083 EN8084 EN8085 EN8086 EN8087 EN8088 EN8089 EN8090

ENCYCLOPEDIA LOADER Single Volumes \$14.95 each*

__Vol. 1 __Vol. 2 __Vol. 3 __Vol. 4 __Vol. 5 __Vol. 6 __Vol. 7 __Vol. 8 __Vol. 9 __Vol. 10
EN8001 EN8002 EN8003 EN8004 EN8005 EN8006 EN8007 EN8008 EN8009 EN8010

Payment enclosed Visa MC Amex

Card # _____ MC Interbank# _____

Signature _____ Expiration date _____

Name _____

Address _____

City _____ State _____ Zip _____

*Shipping and Handling: \$1.50 per item U.S. and Canada. \$10.00 per item overseas airmail.
Books shipped UPS with full street address.

80 REVIEWS

edited by Michael E. Nadeau

“... this bibliography includes only... the academic approach to computer music.”

**A Bibliography of Computer Music
A Reference for Composers**

Sandra J. Tjepkema
University of Iowa Press
Iowa City, IA 52242
Hardcover, 294 pp.
\$17.50

by Dennis Bathory Kitz

Computer music experienced a dramatic resurgence and remarkable changes at the outset of the 1980s. Those changes make *A Bibliography of Computer Music*, by Sandra J. Tjepkema—with only a few entries past 1978—more a historical document than an active reference. But more importantly, this bibliography includes only what might be thought of as the academic approach to computer music, with emphasis on *Computer Music Journal* and the publications of universities and such centers as IRCAM (Institut de Recherche et Coordination Acoustique/Musique) in Paris.

Although much research is being carried out at the university level, a nevertheless significant proportion of computer musical activity is also occurring less formally, as the creative process so often does. By limiting her listings for the most part to official computer, computer music, and professional music publications,

Tjepkema has missed a wealth of important work being done in the computer music field. The inclusion of just one year of the West Coast Computer Faire Proceedings (1977) is a curious demonstration of that limitation.

These drawbacks, though important to working composers—to whom Tjepkema directs the work—do not diminish the heart of the collection itself. The bibliography consists of about 1,000 entries and cross-references covering all phases of computer (as distinguished from analog synthesized) music, including interviews with composers, technical reports, and even user manuals for electronic music studios. Analog synthesis is specifically not covered by this work.

The volume includes over 20 years of writing (1956–1979, most from 1961–1978), with heaviest concentrations during the late 60s (when the avant-gardists and engineers first teamed up) and the second half of the 70s (when microcomputers began to bring digital power to an economically feasible status). Only about 100 entries date before 1965, and these are mainly of historical and artistic interest. Annotations are clear and concise, though the inclusion of many foreign language entries with no annotations at all is discomfiting. The book is cross-indexed by person (both author and subject), but includes a very weak subject index that

greatly limits its usefulness. The glossary of acronyms is minimal, no reference by year is provided, and the manufacturer listing is inevitably dated.

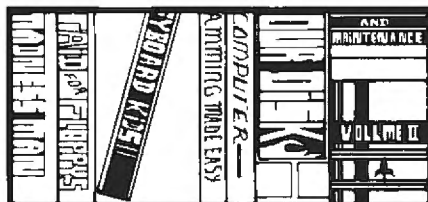

Tjepkema's competence to address the task of such a bibliography is clear, as is her enthusiasm. Compilation of a bibliography is an arduous undertaking, requiring contacts with libraries, authors and publishers across the world. But perhaps it is her enthusiasm that brought about the premature publication of the work, its coverage ending just as a remarkable increase in computer music work was beginning. In any case, a second volume covering work through the mid 80s—even in periodical form—would be very welcome.

To return to the topic of the book's flaws in coverage, major sources of computer music information have not been included, among them the alternative music press (especially from New York City and southern California), composer notes from record jackets, and reprints from seminars and gallery performances in such places as New York's Soho and the Brooklyn Academy of Music. In fact, local (non-academic) work from across the world is missing.

The underrepresentation of the writings of major composers is also unfortunate. Pulitzer Prize winners Morton Subotnik and Charles Wuorinen are not found at all, nor is John Cage, whose collaborations with Lejaren Hiller (amply represented) broke new ground in the field. Charles Dodge and David Behrman, composers of very accessible digitally generated music, are limited to two entries each. The lack of transcripts of public radio programs, record jacket notes, and other so-called ephemera give these leading writers short shrift. On the other hand, long-time academics such as Herbert Brun are ac-

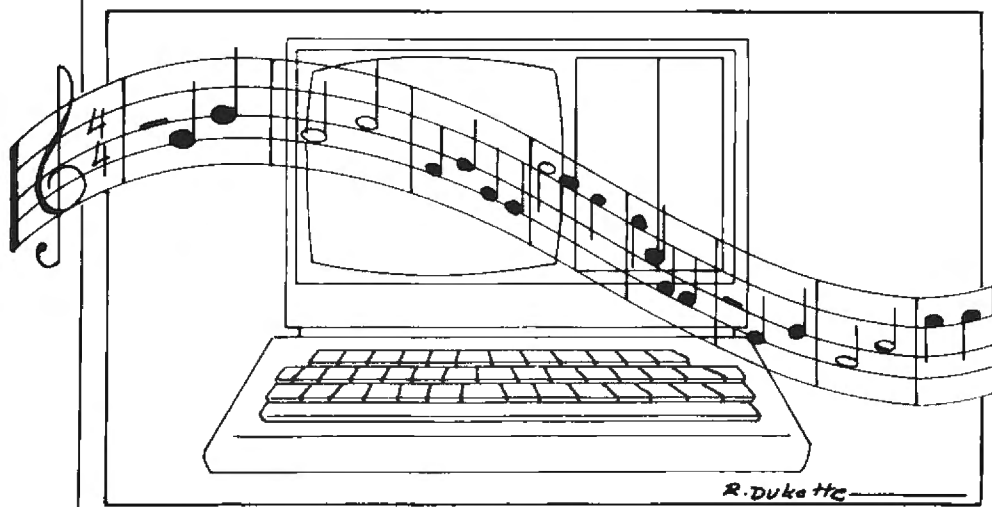

commodated with more than two pages.

Finally, the absence of a discography, —which would partly redeem the exclusion of record jacket notes, cuts off the bibliography from its source: the music itself. The *Schwann Record and Tape Catalog* has listed electronic music separately for several years, and Composers' Recordings Inc. has a complete catalog. Thus, the absence of a discography

“... the bibliography is... an important addition to the musical scholar's library.”

as an integral part of the bibliography is both unfortunate and unnecessary.

In summary, *A Bibliography of Computer Music* fills an important void in a growing field of music composition and performance. Though limited in scope for working composers, the bibliography is nevertheless an important addition to the musical scholar's library. ■

Basic Faster and Better & Other Mysteries
Lewis Rosenfelder
IJG Inc.
1260 West Foothill Blvd.
Upland, CA 91786
Softcover, 300 pp.
\$29.95

by Richard C. McGarvey

Basic *Faster and Better and Other Mysteries* is a book worth its price. As a long-time programmer, I am confident with my skills, but I must admit *Basic Faster and Better* has taught me a few things. If you are a prospective buyer read the preface by Lewis Rosenfelder. If the preface doesn't talk you into buying the book then you do not need it or you are not ready for it.

The introduction answers the question “What is faster and better?” Rosenfelder explains how sacrificing in one area leads to benefits in another. The programmer must decide what results he wants and then make the proper decisions (and sacrifices if necessary) to attain the best operating program he can.

This point is well taken. If speed is important then write your program with speed in mind. You may have to sacrifice long, gingerbread routines that make the program look nice. On the other hand, in order to make a program more user oriented you may have to sacrifice speed.

Rosenfelder's point is the programmer must evaluate the needs of the program and the prospective user. Next he must write a program that is as easy and as fast as possible while using a minimum of memory. The resulting program is Basic that is both faster and better.

You can make one part of a program very fast but not open to much user control. You can also include fancy input routines that are slow but are easy to use in the same program. The object of *Basic Faster and Better* is to show you how to achieve this happy medium in all of the software you write.

Rosenfelder points out many of the errors programmers make. Then he shows you how, based on his own experience, to beat the problems and to actually write better Basic. He explains what trade-offs to make and when they are appropriate.

I wish I could reproduce the table of contents for you in this article. It is so extensive it looks like the index to most other books. Rosenfelder covers every trick of the trade in detail and supplies an invaluable library of subroutines that you can use over and over to reduce memory usage, speed execution and make a program user oriented. If you don't like typing a library of subroutines and demos to keep for future use, you can buy two disks with the routines already on them and ready to merge into your programs (\$19.95 each).

Manipulation of strings, arrays, I/O routines, video displays, keyboard input, utilities and much more are the stock and trade of the programmer. Although Basic programming is the book's main concern, Rosenfelder supplies some machine language. Don't be alarmed, you don't have to understand it to use it. He supplies machine language for proven routines that increase speed in sorting

and other processing tasks and are complete with explanations on how to implement them into your programs.

Although any Basic programmer can gain valuable information from this book it is mainly geared to disk users, though there is plenty of worthwhile information for the non-disk programmer as well.

The book assumes that everyone has a NEWDOS or NEWDOS80 operating system. There may be some incompatibilities with operating systems other than Apparat systems such as in the I/O routines. If you are in doubt, call or write IJG, and ask them about possible problems with your operating system.

Conclusion

The book is worth the money no matter what level of programming ability you possess. If you are one of those who was disappointed in past... & *Other Mysteries* books, give them one more try with this one. Go to your local computer store and sit down with a copy. Read the beginning and take a brief look through the book. It is an honest and successful effort to aid the Basic programmer. *Basic Faster and Better* is the best IJG publication so far. ■

Graphic Software for Microcomputers
B. J. Korites, Ph.D.
Kern Publications
190 Duck Hill Road
P.O. Box 1029
Duxbury, MA 02332
\$19.95

by Terry Kepner

At first glance *Graphic Software for Microcomputers* reminded me of the TRS-80 Level I manual in color and shape, except that it was much thicker. Since I had recently purchased a Radio Shack Color Computer, I was interested in learning more about graphics techniques (the TRS-80 manual was more interested in

telling me about the commands than teaching me the tricks needed for good graphics programming). A quick perusal of the book, and its relatively low cost, decided the matter; I bought it.

This book is a good buy. It not only discusses the theory of operation of the simple points (drawing a line, circle, density filling, and so on), but also covers complicated graphic maneuvers (scaling, rotating, motion translating and the like). The book even provides Basic programs that do each of these activities.

The book was originally written for the Apple computer, but is very easy to use with the TRS-80 Color Computer. All you have to do is to change all the references to HPlot to PSET or LINE, and HCOLOR to COLOR.

Dr. Korites knows how to teach students and how to prepare a reference manual. Each concept is given its own page, which is split vertically between the explanation and the Basic program. You should know simple math and have at least a nodding familiarity with the concept of X-Y Cartesian coordinate systems. Dr. Korites assumes you have no knowledge of the next level of math required which includes vector mathematics and matrix manipulation, subjects familiar to few members of the microcomputer public. He includes sufficient instructions in the text to enable you to understand these ideas well enough to use

the graphics techniques that he explains in the book.

The book begins at the most basic level possible—how to put a dot on the high resolution screen. By the end of the book you should be able to translate, rotate and stretch a box in three dimensions simultaneously.

The book has no absolute page numbering system. Each chapter is numbered using Roman numerals, and the first page of each chapter is labeled page 1. Only one side of each page is actually printed; the reverse is purposely left blank for notes.

This book not only provides the same

theory and practice problems as most graphics books, but also gives usable programs that demonstrate each technique as it is introduced. It starts out at a level perfect for the beginning graphics programmer, but is sectionalized so that the accomplished programmer can easily go to the area that interests him or her and get the needed information. Dr. Korites is to be commended for the thought and effort he has put into making this book as understandable and readable as it is.

I strongly recommend this book to anyone interested in learning how to do shape manipulations on a microcomputer, whether they are simple or complex. ■

Computer Major League: The Game of Professional Baseball
Avalon Hill Microcomputer Games
 4517 Hartford Road
 Baltimore, MD 21214
 Model I, 32K
 \$20 cassette
 \$30 disk

by John P. Mello Jr.

Walk into any place where aficionados of the Grand Game congregate and ask what's the best major league simulation game on the market. You will get a chorus of replies, but if you are looking for harmony, you will find more of it on a street corner in Philly.

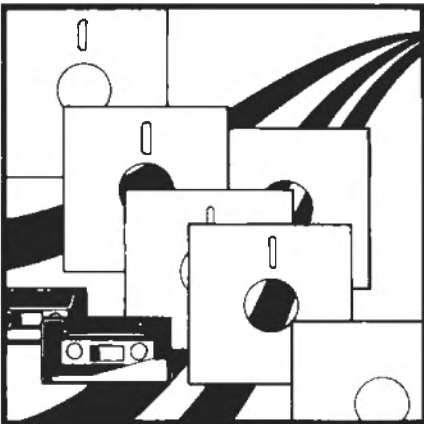

There are the venerable institutions of baseball gaming—APBA and Strat-O-Matic—and at least a dozen newcomers, including Time Travel Baseball, which allows you to move players from one era to another including the future.

Now into the fray enters the prestigious game house, Avalon Hill, with not only a board version of baseball, but one for the microcomputer.

Let there be no misunderstanding. Avalon Hill's computer game is not for the arcade set. It is a text game founded on the baseball fan's unflagging fascination with statistics. To those unschooled in the intricacies of the national pastime, the game may already sound too predictable. But it is no more predictable than the board games and given the vagaries of the Model I, probably less so.

When you load Major League, it takes a few seconds to initialize. This can cause some anxiety about whether the game is loading properly. Palpitations could have been averted with an initializing prompt.

After loading, the game's main menu appears. It summarizes the commands at your disposal in the play mode. You can exit to the menu any time without disturbing a game in progress.

You enter the home and visiting teams and you are ready to set up your lineup. All 26 major league teams and their 25-man rosters from 1980 are included in the game. (Avalon Hill said it intends to market a method to update the game to conform with 1981 performances by the players.) However, repeated attempts to load the Phillies—world champions in 1980—yielded the message "team not found." A look at the disk directory, though, revealed your TRS-80 will find the team from the City of Brotherly Love if you punch in "Phillies."

By keying in V or H you can call up the roster of the visiting or home team. By each fielder is his number, positions he plays, batting average, slugging percentage, and overall running speed. At this point, it would be helpful to know a player's ability to sacrifice and hit and run, but these ratings (along with home run, walk, on-base running, and strikeout ratings) can't be accessed until the game is under way.

Although the documentation notes the

game incorporates a player's fielding ability into the fabric of play, you do not have access to that information—definitely a drawback in the late innings when you are hanging on to a one-run lead and want your best defensive players in the field.

This is also bothersome when your team is batting. If you have a runner on

*"Major League
 takes the drudgery
 out of
 baseball simulation."*

base, you want to know how good a catcher's arm is. In this game, you don't find out until you steal. Then, sometimes, it is too late. Here, though, the offensive player gets an idea about an outfielder's arm. If you have the option of taking an extra base, the chances of your runner making it are displayed as a percentage on the screen.

For anyone that's ever fumbled with a scorecard, Major League is a dream. To set your lineup from the roster mode, you enter three numbers: a player's position in the batting order, number and position (1 for pitcher, 2 for catcher. . .). The numbers appear in three columns to the right of your roster. When you exit to the play mode, the names and stats of the players in the home and visiting lineups are displayed in a column on the left of your CRT.

The game keeps a running scorecard you can access anytime to see what a player or pitcher has done to that point in the contest. Pinch hitter? The computer keeps track of him. New pitcher? Ditto. No more squeezing names at the bottom of your

THE BEST NEW PROGRAM OF THE SEASON ISN'T EVEN ON TV.

The smash hit program is E/Z-SCREEN. You can see it live, in action, right on your computer.

E/Z-SCREEN is the revolutionary new system that makes designing of professional quality screens a snap by letting you design them right on your TRS-80* screen.

Once in place, the E/Z-SCREEN system starts the show by "talking" to you. It automatically produces "user friendly" disk BASIC code, giving you access to a host of screen processing functions.

This and many other E/Z-SCREEN features can save you untold time, effort and can actually make screen design kind of enjoyable! Here's how.

E/Z-SCREEN DESIGN

By using your keyboard, E/Z-SCREEN's formatting commands let you format and modify your screen. Like changing channels, you can keep changing your layout until you're perfectly happy with it. And since what you see on screen is what you get, you never get a layout or write a program you're not completely satisfied with.

Want to center a line? Maybe a few? Just give the command and watch it happen—automagically! You can even repeat information, horizontally or vertically. Best of all, if you still don't like what you see, you can totally rearrange the screen design—even after you've written your program.

E/Z-SCREEN lets you move any and all fields of



information, re-sequence lines, plus much more. And you see it all happen. When you're finally satisfied, save your screen on disk and go on to design another. But after design completion, E/Z-SCREEN really goes to work for you.

THE GRAND FINALE
E/Z-SCREEN automatically generates the screen process code, making your screen work and look like these written for larger industrial computers. The code controls the displaying and reading of data and the printing of text on the screen—for up to 12 screens per program!

What's more, the keyboard operator is truly the program director, in total control of data being entered. Data changes, corrections, and erasures are all made easily by using the various cursor control keys.

A MATTER OF RECORD

E/Z-SCREEN even makes documentation of your program easy by automatically cross-referencing and printing it on paper (if printer is connected to system).

EASY ON THE BUDGET

E/Z-SCREEN costs about the same as an average black and white TV. Only \$149.95.

(Money back guarantee)

So to order, call toll free 800-223-1087.

In N.Y. State call 212-751-8891.

For more information, write SOURCE LIB Systems, Inc., 1670 Pershing St., Valley Stream, N.Y. 11580.

*Compatible with TRS-80 Models I and III, dual disk 48K memory. TRS-80 trademark of Tandy Corp.

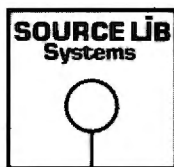

All major credit cards accepted. N.Y. State residents add appropriate sales tax.

scorecard and going batty trying to interpret your hen scratchings. And behold! Major League also contains a print routine so you can print a box score of the game.

Information, however, clutters the play-mode screen. In the upper left, you have the lineups; on the right, the player batting and three rows of information on his hitting and running skills; below that, a baseball diamond; across the bottom, innings, outs, line score and a two-by-two matrix. After several games, we deduced the matrix represented the pitchers' ability rating and fatigue factor. A little labeling here would have been helpful even if it does add to the screen clutter.

Three numbers at the top right of the screen do not seem very useful. The first is a number from 1-12 determining who controls a situation—the batter or pitcher. Which end of the range favors whom, though, isn't explained. The second number is a random number from 1-64 determining the outcome of a play. The higher numbers are usually outs, but there's no

hint whether this number will affect the next play or determined the outcome of the previous one. Third is a number from 1-80 determining if an error's been made. Since a message appears when an error is made, this number seems superfluous.

When your first hitter enters the batter's box, you can make him swing away by hitting the space bar or bunt for a hit by pressing B. When a runner gets on base, his name and on-base running rating is displayed by the sack. With ducks on the pond, the batter has the additional options of hit and run, sacrifice, and suicide squeeze with a runner on third base.

Defensively, your options are limited to moving the infield in or out and pulling pitchers. As batters get hits or bases on balls and runs are scored, a pitcher's stamina is reduced. When it reaches zero, hitters will have a field day.

During a game, the screen may clear and the messages clutch hitting, clutch defense or unusual play will appear. The clutch messages appeared several times

in games played by *80 Micro* staff, but only once did anything clutch happen. Most of the time the batter just had to hit again. According to the game's documentation, unusual plays include an injury to a player, ejection of a player and a rain out. We would add another oddity—one board players don't worry about—Model I glitch.

Despite its drawbacks, computer Major League takes the drudgery out of baseball simulation. Some fans may find it exciting to roll n-sided dice and pore through cards and charts, but as for us, we would rather have a micro do it. After all, the cerebral part of the game is making decisions and reacting to field situations—not acquiring eye strain reading charts.

As for realism, what could be more realistic than the Brewers at Red Sox game we played? Boston struggled through eight innings barely able to scratch out two runs while Milwaukee threatened in almost every inning. Then the patented Fenway fireworks came in the last frame and the final: 5-4 for the home team. ■

electronic mail

A perfect trio—The Hayes Stack Smartmodem, TRS-80, and the Automated Communication Exchange software. Now you can have access to other computers over the telephone line, as well as, time sharing systems and information utilities nationwide.

The Hayes Stack Smartmodem features auto answer & auto dial, RS232C compatibility, seven LED indicators, an audio monitor, accepts over 30 different commands, and is programmable in any language.

The unique A.C.E. software package allows you to receive & transmit ASCII files from your completely unattended TRS-80!

For a sophisticated, high performance, data communication system select A.C.E. and the Hayes Stack Smartmodem.



Hayes Stack Smartmodem \$249
A.C.E. disk software for 48K Model I/III \$79

***** Special—limited time only! *****
A.C.E. Disk software \$39 w/Smartmodem purchase



ACE COMPUTER PRODUCTS OF FLORIDA, INC.
1640 N.W. 3rd Street
Deerfield Beach, FL 33441

Data (305) 427-6300 • Voice (305) 427-1257
MC-VISA accepted Ft. res. add 4% sales tax
Freight incl. (UPS ground—Cont. USA)

✓197

FREE business software directory

- Radio Shack's Model I, II, III.
- Heath's MBASIC and HDOS
- CPM: Xerox, Alto...
- IBM Personal Computer

"IDM2 is GREAT!" -publisher of 80-US

"(GL) superior to either the Osborne (SBSG & Taranto) or Radio Shack... MAIL-X has a greater capacity... more flexible than (R.S.)"

-columnist of 80-microcomputing

"imperceptively fast...(DBMS) is a good and reliable workhorse"

-publisher of Interface Age

Data base manager, integrated accounting package (AR, AP, GL & Payroll), inventory, word processing, and mailing list. Compare and be selective!



Micro Architect, Inc.
96 Dothan St., Arlington, MA 02174

✓149

Asylum
Med Systems Software
P.O. Box 2674-T
Chapel Hill, NC 27514
Models I & III
\$19.95 cassette
\$22.95 disk

by Debra Marshall
80 Micro staff

Another triumphant teaser from Med Systems Software, *Asylum* is all any *Deathmaze* or *Labyrinth* fan could ask for and more. *Asylum* is similar to earlier games, and yet unique; the game board is a maze of halls and doors, but doesn't seem to double onto itself as did *Labyrinth*. While the halls are more straightforward, the situations you find yourself in are not.

Asylum is a huge building full of locked rooms with keys just out of reach, grenades that don't explode — if you handle

them right — nearly bare rooms, crazed inmates, equally crazed guards, and doctors you shouldn't trust. It is a maze of riddles and mysteries. It could drive you insane.

The graphics in *Asylum* differ from those in the two earlier games. In *Deathmaze* and *Labyrinth* it was expected that you would wander halls for hours, days or even months without encountering more than a closed box, an occasional door or keyhole, or a message on a wall. *Asylum* provides a visual relief, with graphic depictions of beds, chairs, desks, doors with bars, inmates, guards, and so on.

The Med Systems people were kind enough to provide me with a graphics sampler disk as well as the game disk to review; I guess they know me well enough to realize that I would be totally intrigued by their game and equally incapable of finding my way around their maze.

As a matter of fact, I couldn't even get out of the first room without help. Either the Med Systems people are finding more obscure commands to use in their games

or I'm slipping. *Asylum* came with a list of commands, which early *Deathmaze* fans never had the advantage of, but I still could not figure out what word would unhook that darn grenade without getting myself blown up. Oh well, half the fun is in the frustration.

Asylum commands are more sophisticated than the earlier games'; the number of commands isn't as limited. The kinds of things it is possible to do has expanded greatly, and while you are not directly interacting with the characters you meet in the maze, they do affect your situation directly. The guards will haul you back to a room and lock you in, but that isn't necessarily a bad situation.

Any game player who likes thinking games and is not totally hooked on the graphicless adventures should like *Asylum*. Even staunch defenders of adventures will like *Asylum*; it is an adventure with a twist. *Deathmaze* and *Labyrinth* players should find *Asylum* a challenge. But be sure to bring along a sharp imagination and a steady patience. ■

T80-FS1 Flight Simulator

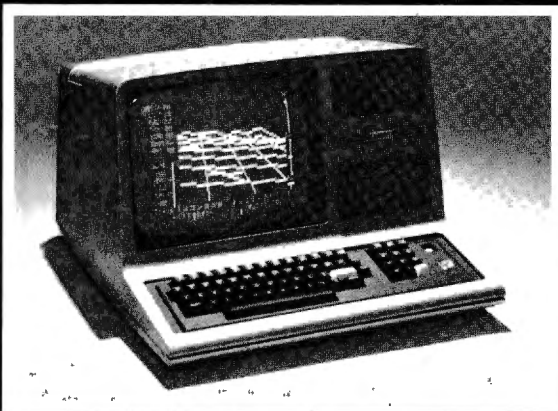

See your dealer!

Available for Model I or Model III. \$25.00 on cassette or \$33.50 on disk (with enhancements) All versions require 16K.

If you order direct, please specify whether you have Model I or Model III (the media are different) and whether you want disk or cassette. Include \$1.50 and indicate UPS or first class mail. Illinois residents add 5% sales tax. Visa and Mastercard accepted.

If you don't yet own a disk, don't fret. You can upgrade anytime. Cassette users may send back their cassette (but not the manual) along with \$10 (first class shipping included) and receive the disk version.

subLOGIC

Communications Corp.
713 Edgebrook Drive
Champaign, IL 61820
(217) 359-8482
Telex: 206995 ↗231

Space Waste Race
Storybooks of the Future
 527 41st Ave.
 San Francisco, CA 94121
Models I & III
\$19.95 16K cassette
\$24.95 32K disk

by Mary Gasiorowski

Space Waste Race is an interactive computerized storybook. Based upon the idea of sending our excess garbage into space to be rid of it, the program is very interactive, and a novel idea. Each nine lines of the story is accompanied by a screen of graphics.

It also allows for a lot of manipulation. The complete story can be viewed without interruption, or individual pages can be repeated as many times as you like. You can practice moving the moons; by pressing the arrows or bracket keys, the face of the man in the moon appears to shake, nod, or look around.

The program has good and bad points. The graphics capability of the TRS-80 is limited to drawing graphics with blocks rather than the dots of the Apple and Col- or Computer. This means that a diagonal line on the Model I or III looks like a stair- case, and moons are not nearly round.

The instructions suggest the program

is designed for non-readers, but the nine- line story includes such vocabulary as "collecting," "jealous" and "imagine." In addition, the on-screen instructions are beyond the young reader. Perhaps the author intended an adult to read through the story with the child.

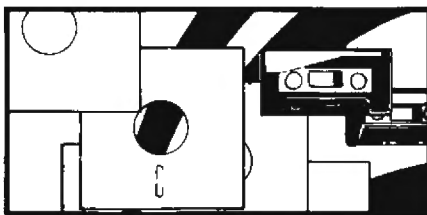

After a cute title page with graphics and a musical theme, the program goes to the menu: Storybook; Look, Nod & Shake; Funtime; End. Storybook and Funtime proceed to other menus. Storybook allows you to run through the story—the whole thing, individual pages, just the text, or just the title page. Look, Nod & Shake lets you play with the moons, making them look in various directions.

The games in Funtime are: Moon Drops, a counting game; Fall Out, a number and letter identification game; Moon Pass, a game for developing the spatial concepts of over and under; Hole in the Moon, a game teaching numerical and alphabeti- cal order; and Moon Looks, a game for

concepts of direction. (The last three are only on the 32K version and feature automatic scoring.)

The games are interesting but trivial; they could be developed more. For exam- ple, in Moon Pass if you miss seeing the moon pass on the screen and do not re- spond to the question in a reasonable amount of time, the program should loop back and show you the problem again. Also, Hole in the Moon takes three numbers or letters in sequence, shows two of them and asks for the missing one. If a mistake is made the program should make you type in the correct answer for positive reinforcement.

In addition, all the games reward equal- ly for correct and incorrect responses: the moon nods for correct answers, and shakes its head from side to side for incor- rect ones. If there was more action for a correct answer the child might be more in- clined to find the right response.

Space Waste Race could be improved in many ways—the games could be more developed and better designed, a more age-appropriate story could be chosen, and the program could be friendlier by asking for your name when you start. However, the idea is an interesting one. Space Waste Race may be the storybook of the future; but Space Waste Race will not replace parents reading to their children. ■

Ann Rose—Our Accounts-Receiveable Clerk
Sturdivant & Dunn Inc.
Box 277, 124 Washington St.
Conway, NH 03818
Models I & III, 48K
\$150

by Frederic S. Goldstein

Ann Rose—Our Accounts-Receiveable Clerk was designed specifically for applications where the majority of the bill- ings are repetitive standard amounts. Gar- bage companies, trailer courts and park-

drives. One is used for the program and data, and the other is used exclusively for data. You can modify the Model III version to run with one disk. This review is based on tests run on a Model I.

On the Model I each pair of disks can handle up to 328 accounts. If you have more accounts, you must use additional sets of disks. You can use any number of sets, however, since the program cannot pass data from one pair of disks to the next. You must establish separate con- trols for each.

Peter G. Dunn, a CPA with the firm of Sturdivant and Dunn, developed the pro-

gram. As such, it has the benefit of per- sonal business experiences in a particu- lar industry. Their experience and this soft- ware, though, may not be universally applicable.

Ann Rose is a bill and post system with many interesting features. When you add a new account, you must code it accord- ing to a table that you have set up. When you select the automatic billing feature, these codes identify which standard rate to charge. You can establish multiple standard rates and apply them to different customers as needed. You can also bill directly in addition to the standard amount. A code of 1 is used for accounts that only incur direct charges.

The system uses a clever technique for posting specific items to an account. It assumes that all positive numbers are charges and all negative numbers are pay- ments. You use the correction routine to change negative amounts from payments into returned items or discounts, and positive amounts from charges into ser- vice charges. You also use the routine to correct account number, invoice number

"(Ann Rose) is part of a new breed of programs. . ."

ing garages which charge a fixed monthly fee will be interested in this program.

The Model I version requires two disk

gram for his firm's internal use. It is part of a new breed of programs developed by users rather than commercial software

SPRING DISCOUNT SALE

SUPERKEYS

ADVANCED OPERATING SYSTEMS

SUPERKEYS is a powerful keyboard utility program which changes your TRS-80 keyboard into a superkeyboard. Now you can perform valuable time-saving single-key programming. Up to 255 different keyboard characters can be assigned to a key or keys. Functions such as RUN, LIST, ENTER, BREAK, and EDIT as well as frequently used graphic strings can be saved and recalled with one key.

Cat. No. 3612 MIII,16K,disk \$49.95

LDOS 5-1

LOGICAL SYSTEMS

The ideal Disk Operating System for your TRS-80 Model I or III computer. Many advanced features allow the novice or professional programmer to fully utilize the power of the Model I or III. Extensive documentation is included.

Cat. No. 3053 MI,L2,32K,disk \$169.00
 Cat. No. 3189 MIII,32K,disk \$169.00

DATALIFE DISKETTES

The symbol of quality for data storage on your TRS-80's or any soft-sector computer. Each disk is rated for 40-track, single or double density operation. Complete with hub rings. Box of 10.

Cat. No. 1147 SINGLE-SIDED \$28.00 by VERBATIM
 Cat. No. 1492 DOUBLE-SIDED \$45.00

MODEL III DISK CONTROLLER

Now Model III owners can upgrade their systems for a fraction of the previous cost. Some of the outstanding features of this controller are:

- single or double density operation
- single or double sided drives
- 40 or 80 track capability

The Model III controller kit comes complete with all boards, cables, mounting hardware, and instructions. Recommended drives are Tandon drives. Installation requires a certain amount of mechanical aptitude.

Cat. No. 3383 \$395.00

COMPLETE DRIVE PACKAGES

Package includes controller kit plus choice of disk drive configurations. Drives used are the Tandon TM100-1 (single-side, 40 track, single/double density) and TM100-2 (double-side, 40 track/side, single/double density).

SINGLE DRIVE CONFIGURATIONS	DUAL DRIVE CONFIGURATIONS
(1) TM100-1 \$549.00	(2) TM100-1's \$795.00
Cat. No. 3426	Cat. No. 3427
(1) TM100-2 \$725.00	(2) TM100-2's \$1099.00
Cat. No. 3428	Cat. No. 3429

HOW TO ORDER

Write or phone. Pay by check, M/C, VISA, or
 COD (add \$1.50 for COD).

(800) 423-5387 (213) 886-9200

Offer expires June 30, 1982.

Mention this ad and we pay shipping (UPS ground only).

WHEN IN SOUTHERN
 CALIFORNIA.
 VISIT OUR RETAIL
 STORES

HAW ELECTRONICS

19511 Business Center Dr. 2301 Artesia Blvd.
 Northridge, CA 91324 Redondo Beach, CA 90277

FREE SHIPPING
 FREE SHIPPING
 FREE SHIPPING

or dollar-amount problems.

There is one report format for posting transactions and one for recording the journal entry. I recommend that you enter each category of transaction—payments, returned items, and so forth—as a separate batch with its own entry run.

This is a balance-forward system. It is unique in that it offers the option of saving and printing 17 transactions along with the balance due.

If you do not save the details, transaction capacity should never be a problem since only the net is carried forward. If you save the transactions, when you enter the seventeenth item for an account the system stops what it is doing and prints a detailed report for the account. The program then purges the 17 details and resumes posting.

In reality Ann Rose is a 17-line computerized ledger card. Unfortunately, since the system cannot key payments against specific charges, problems could develop if you had to reconcile a high volume account. Because the program prints only 17 transactions and the net balance due, the amount paid could be for details previously purged.

The monthly report of customer balances requires some explanation since at first glance it looks to be out of balance. The detail columns provided—service charge, 30-60 days, and over 60 days—do not necessarily total to the balance-due column. The difference is the current amount due, which you find on the posting-to-accounts-receivable report. Since the system is set up to print at 10 pitch on 8½ by 11-inch paper, space is at a premium and some information was omitted. Mr Dunn should have included the total balance due as a single number or used a short name for the customer so that the report would crossfoot.

The program provides an accounts-receivable list with the account number, code, name, phone number and blank spaces in the columns labeled charge and payment. At first, it appears that it should contain a recap of the financial figures, but it is intended as a worksheet for the bookkeeper.

The system calculates interest at the rate of 1½ percent per month on balances over 30 days late.

The system's major weakness is its documentation. The manual starts out by providing a step-by-step list of instructions for formatting new disks and backing up and copying the program from the non-system disk provided. The documentation explicitly reminds the user to make adequate back-up copies every time he runs the system. (After terminating pro-

cessing, the system even displays a parting message of "MAKE BACKUPS.")

Unfortunately, there is very little follow-up documentation on how to run the system. Essentially, the manual says "experiment!" This is an excellent way to learn about the system, but reading about it first would have been better. A new and expanded version of the documentation should be available soon.

In addition to the incomplete documentation, the system has other deficiencies. For example, bills are printed without account numbers and there is no provision for sales analyses or commission analyses.

Although Ann Rose is not as widely distributed as the Radio Shack Receivable system, the program developer and sever-

al of his clients, including a garbage company with 2,000 accounts and a utility company with about 1,000 accounts, are using it successfully. The developer is still modifying the system and improvements will evolve such as order entry processing and some form of inventory control. This will make the package less industry specific.

Would I recommend this system to a client? Yes, but only under special circumstances. At present Ann Rose could be ideal for a small business with repetitive standard billings. However, the lack of comprehensive documentation limits its usefulness to someone already familiar with data processing and the industries for which the package was designed. In that instance you should find it easy to install and use. ■

The Voyage of the Valkyrie
Leo Christopherson
Advanced Operating Systems
 450 St. John Rd.
 Michigan City, IN 46360
 Models I & III, sound
 \$34.95 16K cassette
 \$39.95 16K disk

by Michael E. Nadeau
 80 Micro staff

Graphics and sound can make or break a computer game; both are done very well in *The Voyage of the Valkyrie*.

The game itself is no innovation. You are the pilot of the ship *Valkyrie*; your mission is to capture the island of Fugloy. The island has 10 castles, each guarded by a different number and type of bird. Your first task is to map the island. Roughly two hours of trial and error gives you the map, but be prepared to die a few times in the process.

You must shoot the birds to capture castles. The elite Fugloy Airforce can appear anywhere on the island. These birds shoot back; some are more powerful and quicker than others. Each shot consumes valuable energy points. You must also keep an eye on your shield level. To shoot the birds you must aim crosshairs that appear on the screen when you put on your shields. How well you aim these crosshairs bears directly on your success at the game.

There are 10 levels of play, with each successive level putting more birds into the fight. Once you have mastered the art of shooting birds, however, the game only becomes longer with each increase in difficulty level.

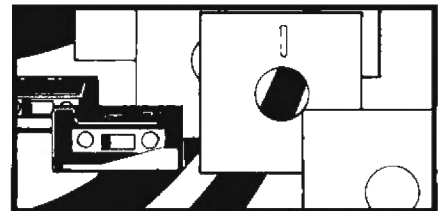

The graphics are undoubtedly the best feature of *Valkyrie*. The birds move unpredictably (at first) with their wings flapping and shots flashing. The castles are all different and equally impressive. Few games can boast TRS-80 graphics as good as these.

When you first play *Valkyrie*, it is very difficult to shoot the birds. Eventually patterns emerge and the game becomes much easier to play. I am most dissatisfied with this fact. Once you map the game and develop your shooting technique the game ceases to be a challenge.

Yet the game remains entertaining because of the graphics and an unusual use of sound (selections from Richard Wagner's operas). The game begins with the March from "Tannhauser"; "The Ride of the Valkyrie" (my favorite) plays each time you capture a castle. The Prelude from Act III of "Lohengrin" signals that you have conquered the island. There are the usual blips and blaps as well, but they are uninspiring.

I like this game, but I cannot recommend it to anyone who wants a challenge everytime it is played. The game is quickly mastered and can become tedious. The graphics and sound redeem what would otherwise be a mediocre game. ■

Just when you thought it was safe to go back to the keyboard. . .



ASYLUM II

. . . the adventure continues. The graphics wizardry of Frank Corr and the deadly imagination of William Denman have once again joined forces to produce a world of evil genius. Hordes of maddened army ants will pick your bones. Killer clowns will send you screaming. Clever guards will tax your ingenuity. And a hundred other confrontations with a nightmare world may leave you a babbling idiot.

Graphics are instantaneous and three-dimensional. The building has over 1500 locations. Full English sentences may be entered, with comprehension surpassing the legendary Asylum I.

You need not have seen Asylum I in order to master Asylum II. You will need cunning and stealth to survive this newest world of insanity.

The industry greeted Asylum I with one word. Incredible. For Asylum II, only one word is required . . . AWESOME!

TRS-80 Model I/Model III / Tape: \$19.95/Disk: \$22.95

MED SYSTEMS SOFTWARE

P.O. BOX 3558, CHAPEL HILL, NC 27514
TO ORDER, CALL: 1-800-334-5470

FREE
with software purchase—
One CPM Handbook

DISCOUNT SOFTWARE

Ad#25

ULTIMATE SOFTWARE PLAN

We'll match any advertised price on any item that we carry. And if you find a lower price on what you bought within 30 days of buying it, just show us the ad and we'll refund the difference. It's that simple.

Combine our price protection with the availability of full professional support and our automatic update service and you have the Ultimate Software Plan.

It's a convenient, uncomplicated, logical way to get your software.

✓ (New items or new prices)

* Special price of the month.

CP/M users:
specify disk systems and formats. Most formats available.

CP/M®

DISK WITH / MANUAL ONLY

ARTIFICIAL INTELLIGENCE*
Medical (PAS-3) \$349/\$40
Denial (PAS-3) \$349/\$40

ASYST DESIGN*
Prof Time Accounting \$549/\$40
General Subroutine \$269/\$40
Application Utilities \$439/\$40

COMPLETE BUS. SYSTEMS*
Creator \$199/\$25
Reporter \$129/\$20
Both \$299/\$45

COMPUTER CONTROL*
Fabs (B-tree) \$119/\$20
UltraSort II \$119/\$25

COMPUTER PATHWAYS*
Pearl (level 1) \$99/\$25
Pearl (level 2) \$299/\$40
Pearl (level 3) \$549/\$50

DIGITAL RESEARCH*
CP/M 2.2
NorthStar \$149/\$25
TRS-80 Model II (P+T) \$159/\$35
Micropolis \$169/\$25

PL/I-80 \$459/\$35
BT-80 \$179/\$30
Mac \$85/\$15
Sid \$65/\$15
Z-Sid \$90/\$15
Tex \$90/\$15
DeSpool \$50/\$10
CB-80 \$459/\$35
CBasic-2 \$98/\$20

D.M.A.
Ascot \$149/\$15
Formula \$539/\$45

GRAHAM-DORIAN*
General Ledger \$729/\$40
Acct Receivable \$729/\$40
Acct Payable \$729/\$40
Job Costing \$729/\$40
Payroll II \$729/\$40
Inventory II \$729/\$40
Payroll \$493/\$40
Inventory \$493/\$40
Cash Register \$493/\$40
Apartment Mgt \$493/\$40

MICRO-AP*
S-Basic \$269/\$25
Selector IV \$295/\$35
Selector V \$495/\$50

MICRO DATA BASE SYSTEMS*
HDBS \$269/\$35
MDBS \$795/\$40
DRS or ORS or RTL \$289/\$10
MDBS PKG \$1295/\$60

MICROPRO*
WordStar \$319/\$80
Customization Notes \$429/\$na
Mail-Merge \$109/\$25
WordStar/Mail-Merge \$419/\$85
DataStar \$249/\$60
WordMaster \$119/\$40
SuperSort I \$199/\$40
Spell Star \$175/\$40
CalcStar \$259/\$na

MICROSOFT*
Basic-80 \$298
Basic Compiler \$329
Fortran-80 \$349
Cobol-80 \$629
M-Sort \$175
Macro-80 \$144
Edrt-80 \$84
MuSimp/MuMath \$224
MuLisp-80 \$174
Multi Plan Call
Manager Series Call

ORGANIC SOFTWARE*
TextWriter III \$111/\$25
DateBook II \$269/\$25
Milestone \$269/\$30

OSBORNE*
General Ledger \$59/\$20
Acct Rec/Acct Pay \$59/\$20
Payroll w/Cost \$59/\$20
All 3 \$129/\$60
All 3 + CBASIC-2 \$199/\$75
Enhanced Osborne \$269/\$60

PEACHTREE*
General Ledger \$399/\$40
Acct Receivable \$399/\$40
Acct Payable \$399/\$40
Payroll \$399/\$40
Inventory \$399/\$40
Surveyor \$399/\$40
Property Mgt \$799/\$40
CPA Client Write-up \$799/\$40
P5 Version Add \$129
MagiCalc \$269/\$25
Other less 10%

SOFTWARE WORKS*
Adapt (CDOS to CP/M) \$49/\$na
Raltor \$68/\$na

SOHO GROUP*
MatchMaker \$89/\$20
WorkSheet \$159/\$20

STRUCTURED SYSTEMS*
Business Packages.
Call for Price

SORCIM*
SuperCalc \$269/\$na
Trans 86 \$115
Act \$157

TCS*
GL or AR or AP or Pay \$79/\$25
All 4 \$269/\$99
Compiled each \$99/\$25
Inventory \$99/\$25

SUPERSOFT*
Diagnostic I \$49/\$20
Diagnostic II \$84/\$20
Disk Doctor \$84/\$20
Forth (B080 or Z80) \$149/\$30
Fortran \$219/\$30
Fortran w/Raltor \$289/\$35
C Compiler \$174/\$20
Star Edit \$189/\$30
Other less 10%

UNICORN*
Mince \$149/\$25
Scribble \$149/\$25
Both \$249/\$50

WHITESMITHS*
C Compiler \$600/\$30
Pascal (incl C) \$850/\$45

"PASCAL"
Pascal/MT+ Pkg \$429/\$30
Compiler \$315
Sp Prog \$175
Pascal/Z \$349/\$30
Pascal/UCSD 4.0 \$670/\$50
Pascal/M \$355/\$20

"DATA BASE"
FMS-80 \$649/\$45
dBASE II \$595/\$50
Condor II \$899/\$50

"WORD PROCESSING"
WordSearch \$179/\$50
SpellGuard \$229/\$25
Sp/80 \$259/\$65
Magic Wand \$289/\$45

Magic Spell \$269/\$25
Spell Binder \$349/\$45
Select \$495/\$na
The Word \$65/\$na

"OTHER GOODIES"
Micro Plan \$419/\$na
Plan 80 \$269/\$30
Target \$189/\$30
BSTAM \$149/\$na
BSTMS \$149/\$na
Tiny C \$89/\$50
Tiny C Compiler \$229/\$50
Nevada Cobol \$179/\$25
MicroStat \$224/\$25
Vedit \$130/\$15
MiniModel \$449/\$50
StatPak \$449/\$40
Micro B \$229/\$20
Raid \$224/\$35
String/80 \$84/\$20
String/80 (source) \$279/\$na
ISIS CP/M Utility \$199/\$50
Lynx \$199/\$20
Supervyz \$95/\$na
CP/M Power \$75/\$na
Mathe Magic \$95/\$na

APPLE II®

INFO UNLIMITED*
EasyWriter \$199
Datadex \$249
EasyMailer \$128
Other less 15%

MICROSOFT*
Softcard (Z-80 CP/M) \$298
Fortran \$179
Cobol \$499
Tasc \$139

MICROPRO*
Wordstar \$269
MailMerge \$99
Wordstar/MailMerge \$349
SuperSort I \$159
Spellstar \$129

PERSONAL SOFTWARE/ VISICOR*
Visicalc 3.3 \$225
Desktop/Plan II \$225
Visitem \$90
Visidex \$225
Visipilot \$180
Visitrend/Visipilot \$300
Visifile \$225

PEACHTREE*
G/L, A/R, A/P Pay or Inventory (each) \$224/\$40

"OTHER GOODIES"
VU #3R (use w/Visicalc) \$49
Context Connector (use w/Visicalc) \$99
Micro Courier \$219
Super-Text II \$127
Data Factory \$134
DB Master \$184

IBM PC SOFTWARE

Business/Med/WP Call for Price

8086 SOFTWARE
CBASIC 86 \$300/\$na
Pascal MT + 86 Pkg \$730/\$na
Super-Text 86 \$700/\$na
Macro 86 \$259/\$na

80 REVIEWS

Life List
Manhattan Software
P.O. Box 1063
Woodland Hills, CA 91365
Models I & II
\$24.95

by Eric Maloney
Kilobaud Microcomputing staff

My Life List program tells me I saw a Double-Breasted Tuna Grinder in Antrim, NH, last weekend. The weekend before, I ran across a Black-Billed Boot Stomper behind Dr. Fred's Auto Clinic. According to my notes, I blew the dirty little thing away with my grenade launcher.

How I managed before Manhattan Software came up with this bird list program I will never know. My closets were full of shoeboxes stuffed with matchbook covers, napkins, bank deposit slips, grocery store receipts—anything to

"I blew the dirty little thing away..."

scrawl a note on when I unexpectedly spied a Double-Shagged Throw Rug or Red-Eyed Fly Hog.

Naturally, my notes got confused. Was it a Clip-Winged Tarsucker that I flattened with my moped? Did I really see the rare Tie-Dyed Burger Bun while floating in my sensory deprivation tank? And where is that recipe for White-Crowned Sparrow fritters?

Life List takes care of all my problems. It lets me record the names of some 450 birds, along with the date and place sighted and any extra notes. I can sort the list alphabetically and get a complete printout with the touch of a button. I can perform a special search for any bird, using only part of its name.

Of course, the people who might possibly be interested in this program would probably fit into a phone booth, with room left over for an hors d'oeuvres table. But Charles Leedham of Manhattan Software says this is the sort of specialized offbeat program that microcomputers were made for.

After transferring my notes to disk, I was faced with another dilemma—what to do with all of those shoeboxes. It finally dawned on me, they would be perfect for storing field specimens. At last my roommate has stopped complaining about those stuffed birds under the kitchen sink. ■

ORDERS ONLY—CALL TOLL FREE VISA • MASTERCHARGE
1-800-854-2003 ext. 823 • Calif. 1-800-522-1500 ext. 823

Outside Continental U.S.—add \$10 plus Air Parcel Post • Add \$3.50 postage and handling per each item • California residents add 6% sales tax • Allow 2 weeks on checks, C.O.D. \$3.00 extra • Prices subject to change without notice. All items subject to availability • ®—Mfgs. Trademark. Blue Label \$3.00 additional per item.

THE DISCOUNT SOFTWARE GROUP

6520 Selma Ave. Suite 309 • Los Angeles, Ca. 90028 • (213) 837-5141
Int'l TELEX 499-0446 DISCSOFT LSA • USA TELEX 194-634 (Attn: 499-0446) ✓ 101
TWX 910-321-3597 (Attn: 499-0446)

The only complete document proofreading system:

GRAMMATIK™

Beyond Spelling Checking

+

PROOFREADER™

The Aspen Software Company Spelling Checker

= NO ERRORS

For CP/M® , TRS-80® , and 8086/8088 Word Processors

Don't settle for a partial proofreading program. There are other spelling checkers available, but only Aspen Software offers a complete document proofreading system.

The Aspen Software Company spelling checker is Proofreader. We've been improving Proofreader since it was first released in early 1981. The newest version is fully menu driven, and so simple to use that you probably won't even need the comprehensive user's manual that's included. It has a large 38,000 word fully expandable dictionary, and can check even your largest documents in under four minutes (even faster on most systems). Proofreader's dictionary is almost twice as large as some, so you won't have to spend so much time adding new words. And Proofreader is totally accurate. Proofreader looks up every word in its dictionary, and does not artificially extend its dictionary size with less accurate prefix and suffix analysis like some others. (Beware: Most checkers with "vocabularies" of 50,000 or more words use this method and can miss some misspelled words!) The entire 38,000 word dictionary takes only 100,000 bytes of disk space.

Proofreader does not simply mark the errors in your document like some checkers, but allows you to make corrections interactively, with the full context of each unknown word displayed. You can correct mistakes, leave unknown words alone, or add words to the dictionary. Unlike most spelling checkers, you also have complete interactive access to the dictionary while correcting, so you won't need to keep a separate dictionary to look up words manually. Each correction is automatically double checked in the dictionary, and with a single command, Proofreader can almost always show you the correct spelling of a word. (Interactive correction optional on TRS-80 Model I/III, included on all other versions. TRS-80 versions do not support interactive dictionary look up.)

Spelling checking alone is not enough! Aspen Software's Grammatik goes beyond simple spelling checking. No one else has anything like it. First, Grammatik will check your document

for common typos (such as doubled words: "the the"), and punctuation and capitalization errors (e.g., "Sticky shift key"). It also checks for poor writing style using a dictionary of over 500 misused phrases as defined in many writer's style manuals. Grammatik classifies each error it finds, marks the errors for easy correction with your word processor, and provides suggestions for correcting the problem. The phrase dictionary can easily be expanded to include checking for esoteric jargon or your own personal pet peeves. Grammatik also collects other information that can help you judge the style of the document, and can produce a profile of word usage.

Grammatik is receiving rave reviews from both critics and users. Bob Loudon in InfoWorld (12/7/81): "If you use a word processor and a spelling checker, then you should investigate the unique capabilities of this program. Grammatik is a surprisingly fast and easy tool for analyzing writing style and punctuation." Eric Balkan in The Computer Consultant: "I'm impressed with the imagination that went into this product." Many users call or write to tell us how much they like Grammatik. Some typical remarks: "Great!", "Thanks for making my life easier.", "I'm not just happy, I'm ecstatic!". Grammatik has also been selected as an officially approved Osborne Computer software package and will soon be appearing at Osborne dealers.

Only Proofreader and Grammatik can provide you with complete document proofreading, and together cost less than some spelling checkers alone. Proofreader and Grammatik have been designed to work with almost any CP/M, TRS-80, or 8086/8088 based word processor. While they have been designed to work together, they are available separately.

Aspen Software also has its own full featured word processor called Writer's Companion for all these systems. One of the best implementations of Ratfor (Rational Fortran) is available, too, along with an automatic Ratfor pretty printer. Please call or write for more details about these products.

--CP/M versions require CP/M version 2 or later and at least 48K of RAM. Standard 8" single density, Northstar, Osborne-1, Omikron, and Apple formats available directly from Aspen Software. These and most other formats also available from Digital Marketing. Some CP/M systems with limited disk capacity supplied with 28,000 word, 65,000 byte dictionary. Proofreader - \$129.00, Grammatik - \$150.00, Both - \$250.00.

--Manuals only \$8.00 each, \$15.00 for both.

--TRS-80 Model I/III versions require only one disk drive and 32K of RAM, and are compatible with all TRS-80 word processors and operating systems. Model II version requires 64K and 1 drive. TRS-80 Model I/III: Proofreader - \$59.00, Interactive correction option - \$30.00, Grammatik - \$59.00, All - \$139.00. TRS-80 Model II: Proofreader - \$99.00, Grammatik - \$99.00, Both - \$179.00.

--The 8086/8088 version will run under MS/DOS or equivalent (including the IBM Personal Computer DOS). MS/DOS formats available include standard single density 8" and IBM PC 5.25". CP/M-86 versions scheduled for Summer 1982 availability. Proofreader - \$129.00, Grammatik - \$150.00, Both - \$250.00.

IMPORTANT ORDERING INFORMATION: You MUST specify computer model, operating system, memory size, and format and number of disk drives when ordering either software or manuals alone. Please include your phone number. All U.S., Canada, and Mexico orders include first class shipping in price. Overseas please add \$5.00. We accept cash, check, money order, VISA and Master Card. Sorry, no UPS or COD service available. Purchase orders accepted from educational institutions and nationally recognized corporations only. Cost of manual only orders can be credited to final purchase. NM residents add 4% sales tax.

Aspen Software products distributed exclusively by Aspen Software Company and Digital Marketing. Dealer and OEM inquiries welcome.

Trademarks: CP/M: Digital Research; TRS-80: Tandy Corp.; MS-DOS: Microsoft; Proofreader, Grammatik: Aspen Software Co.



ASPEN SOFTWARE COMPANY™

P.O. Box 339-M Tijeras, NM 87059 (505) 281-1634

65

ZBasic 2.0
Simutek Computer Products
 P.O. Box 13687
 Tucson, AZ 85732
Models I & III
\$79 cassette
\$89 disk

by Bruce Powel Douglass

ZBasic is back and is vastly improved. In a previous review I said it had some major problems, including integer math only, non-relocatable object programs, and it did not support all variable names. These and other flaws have been corrected.

I received ZBasic 2.0 on disk with a boot loader. It has several files for various memory sizes and a program from Miso-sys called CMDFILE, which saves compiled programs as tape System files. The program runs on Models I and III, enabling you to write software for the Model III on your Model I.

ZBasic is easier to use than ever. When calling ZBasic from disk (or load from tape), it interfaces with the keyboard device control block. To execute the compiler from Basic, press the comma, period and slash keys simultaneously. The compilation speed is slightly slower than the old version, but it is still incredibly fast. Compiled program speed is fast, too. Basic took over 50 seconds to write out the screen using a tight SET loop; ZBasic whites it out in under one second.

ZBasic still lets you jump back and forth between your Basic and compiled programs, making it the *only* interactive compiler available for any machine, to the best of my knowledge. ZBasic also allows the use of TRON/TROFF to trace the execution of compiled programs.

The Options

After loading the compiler, ZBasic asks if you wish to change any parameters. If you do not, the compiler loads normally; if you do, you may choose a variety of options including: maximum string array size, maximum regular string length, top of available RAM, and base address of the object program.

The last two options let you choose where the variables and the program are to be stored in memory. This corrects a major fault in ZBasic 1.0; now you can relocate your object programs. Two significant results are: You can use your 48K or 32K machine to write software for 16K machines; and you may relocate your program where Basic resides normally if it is very large with large variable-space memory requirements. The latter enables

you to write much larger programs than possible before.

The Manual

The manual is also much improved. Simutek has added an index (although some page numbers are wrong) and a command description section. It is easier to read and contains more useful information, such as the command syntax, dif-

- Cassette input/output (I/O)
- Single-byte disk I/O (good for saving graphics screens to disk)
- Enable/disable interrupts
- Read stack pointer
- 16-bit PEEK
- Improved user-defined machine-language routine calling commands (pass four or six registers)

These commands are called using the

*"The compilation speed
 is slower,
 but still incredibly fast."*

ferences between the Basic and ZBasic versions of the commands, and examples of the commands.

ZBasic 2.0 supports high-precision mathematics. It can carry about 62 significant digits through the use of binary coded decimal math routines. (You may define this to be less during configure time.) None of the transcendental math functions are supported, but the manual supplies routines to generate them as needed.

The high-precision math is computed in an interesting manner. To add two high-precision numbers, rather than write $A = A * C$, write $@ AS = AS * CS$; the @ tells the computer that the string operations are actually high-precision math. It is different, but with a little practice it is no problem. In fact, by using the appropriate Taylor series and other approximate algorithms, accuracy improves for a variety of mathematical functions over mere double precision in Basic. ZBasic can now be used for some types of scientific numerical processing, particularly those sensitive to roundoff error such as Gauss-Jordan elimination for unstable systems and polynomial synthetic division.

The compiler is available with and without the high-precision math routines. The routines use about 700 bytes of memory; if you need this space you can simply use the version without them.

ZBasic 2.0 has several improvements over Basic:

- Block move of memory (10,000 bytes per second)
- Compare (i.e., find byte sequence in memory)
- Invert memory (great for graphics)
- Tone generator (for external speaker)
- High-speed multiply and divide

unused Basic tokens. For example, block moves are done using SIN or COS commands, and the compare functions use the CINT and CDBL commands. The special USR calls use the TAN and MKI\$, MKS\$ and MKD\$ functions. These commands are easy to use and well explained.

The tone generator is a nice feature. To use it, choose the frequency (pitch), duration and a constant to generate tones requiring an external amplifier. My only reservation is the tone duration is not a *time* duration, but a *cycle* duration. For high-frequency tones, the cycles are shorter and you must do some extra programming to keep the length of the tones consistent in terms of real time. If this had been fixed in the compiler it would be more useful. You may use these tones as a high-accuracy, time-delay loop as well.

ZBasic is an interactive compiler, meaning your source, object (compiled) and compiler programs are all coresident in memory simultaneously. When you activate the compiler, ZBasic compiles your programs and gives you the options of returning to Basic, running the compiled program, or saving the program to disk or tape. If you set the configuration to relocate your object program elsewhere, you cannot execute it, but you can save it to disk or tape. This means you can run the program in your programming environment, and compile it to run in the object environment. If you have dreams of writing 16K machine games on your 48K computer, ZBasic may prove invaluable.

Error Detection

When the compiler detects an error, it returns an error message, error line number, and returns control to Basic. This makes it relatively easy to remove errors

PROGRAMMING TOOLS FOR YOUR TRS-80™ MODEL I AND MODEL III

INSIDE LEVEL II

The Programmers Guide to the TRS-80 ROMS

INSIDE LEVEL II is a comprehensive reference guide to the Model I and Model III ROMS which allows the machine language or Basic programmer to easily utilize the sophisticated routines they contain. Concisely explains set-ups, calling sequences, and variable passage for number conversion, arithmetic operations, and mathematical functions, as well as keyboard, tape, and video routines. Part II presents an entirely new composite program structure which loads under the SYSTEM command and executes in both Basic and machine code with the speed and efficiency of a compiler. In addition, the 18 chapters include a large body of other information useful to the programmer including tape formats, RAM usage, relocation of Basic programs, USR call expansion, creating SYSTEM tapes of your own programs, interfacing of Basic variables directly with machine code, and special precautions for disk systems. **INSIDE LEVEL II** is a clearly organized reference manual. 80 Microcomputing calls it "a volume of valuable information...immensely thoughtful literature, and clearly designed." Byte Magazine says "I recommend this book to serious machine language programmers."

Includes updates for Model III. INSIDE LEVEL II.....\$15.95

SINGLE STEP THROUGH RAM OR ROM

STEP80 allows you to step through any Basic or machine language program one instruction at a time and see the address, hexadecimal value, Zilog mnemonic, register contents and step count for each instruction. The top 14 lines of the video screen are left unaltered so that the target program may perform its display functions unobstructed. **STEP80** will follow program flow right into the ROMS, and is an invaluable aid in learning how the ROM routines function. Commands include step (trace), disassemble, run in step mode at variable stop rate, display or alter memory or CPU registers, jump to memory location, execute a CALL, set breakpoints in RAM or ROM, write SYSTEM tapes, and relocate to any page in RAM. The display may also be routed to your line printer through the device control block so custom print drivers are automatically supported.

Specify Model I or Model III. STEP80.....\$16.95

SMART TERMINAL PROGRAM

This machine language program may be used as a smart terminal with time share systems or for high speed file transfers between two disk-based micros over modems or direct wire. It is menu driven and extremely simple to use. Functions include real-time terminal mode, save RAM buffer on disk, transmit disk file, receive binary files, examine and modify UART parameters, program 8 custom log-on messages, automatic 16-bit checksum verification of accurate transmission and reception, and many more user conveniences. Supports line printers and lowercase characters. With this program you will no longer need to convert machine language programs to ASCII for transmission, and you will know immediately if the transmission was accurate. This program comes on a formatted disk.

Specify Model I or Model III. TELCOM.....\$39.95

PROGRAM INDEX VERSION 2.0

Assemble an alphabetized index of your entire program library from disk directories. Program names and free space are read automatically (need not be typed in) and may be alphabetized by disk or program. The list may also be searched for any disk, program, or extension, disks or programs added or deleted, and the whole list or any part sent to the printer. Printer output may be requested in three different formats including labels. The list itself may also be stored on disk for future access and update. It also includes a PURGE mode for quickly killing unwanted files. Directory reads and alphabetizing is done in machine code for speed. 1,000 programs may be sorted in less than 10 seconds. 80 Microcomputing called it "The best thing since sliced bread." It works with TRSDOS, OS-80, NEWDOS, and NEWDOS/80 single or double density. One drive and 32K required.

Specify Model I or Model III. INDEX.....\$24.95

4 SPEED OPTIONS FOR YOUR TRS-80

The SK-2 clock modification allows CPU speeds to be switched between normal, an increase of 50%, or a 50% reduction, selectable at any time without interrupting execution or crashing the program. Instructions are also given for a 100% increase to 3.54 MHz. The SK-2 may be configured by the user to change speed with a toggle switch or on software command. It will automatically return to normal speed any time a disk is active, requires no change to the operating system, and has provisions for adding an LED to indicate when the computer is not at normal speed. It mounts inside the keyboard unit with only 4 necessary connections for the switch option (switch not included), and is easily removed if the computer ever needs service. The SK-2 comes fully assembled with socketed IC's and illustrated instructions.

Model I only. SK-2.....\$24.95

INSTANT ASSEMBLER NOW ON DISK!

The **INSTANT ASSEMBLER** is a powerful disk or tape-based assembler and debugger for the TRS-80. Now you can assemble directly to memory and immediately debug your program with the built in single stepping debugger. Quickly switch from assembler to debugger and back again without losing the source code. This feature makes **INSTANT ASSEMBLER** an excellent learning tool for assembly language programming.

INSTANT ASSEMBLER is absolutely unique among tape based assemblers in that it produces relocatable code modules that can be linked with the separate **LINKING LOADER**, which is supplied in two versions for loading programs into either high or low RAM. This lets you build long programs with small modules. **INSTANT ASSEMBLER** also features immediate detection of errors as the source code is entered, a compactly coded source format that uses 1/3 as much memory as standard source, and many operational features including single stroke entry of DEFB and DEFW, pinpoint control of listings, alphabetic listing of symbol table, separate commands for listing error lines or the symbol table, block move function, and verification of source tapes.

INSTANT ASSEMBLER's debugger provides single stepping with full register displays, decimal or hex entry of addresses, forward or backward memory displays, disassembly of object code in memory, memory display in ASCII format, and hex-to-decimal or decimal-to-hex conversion. The single-stepper will step one instruction at a time or at a fast rate to any defined address.

INSTANT ASSEMBLER occupies less than 8400 bytes of memory. In a 16K machine this will leave you enough memory to write assembly language programs of around 2000 bytes. This and its module-linking feature make **INSTANT ASSEMBLER** ideal for users with only 16K machines. The instruction manual may be purchased separately for \$3, which will apply towards the purchase of the **INSTANT ASSEMBLER**. In addition to disk I/O, the disk version includes a stand-alone version of the debugger.

Specify Model I or Model III. TAPE INTASM.....\$29.95

Specify Model I or Model III. DISK INTASM.....\$35.95

RESTORE DAMAGED TAPES WITH RESQ2

Cassette recordings are subject to several types of damage. Thin spots in the oxide, dirt, voltage fluctuations while recording, or stray magnetic fields can all contribute to lost or added bits. **RESQ2** was written to provide a method of restoring tapes that can no longer be loaded for these reasons. It can restore BASIC, SYSTEM, ASSEMBLER, and DATA tapes. **RESQ2** compares two copies of the damaged tape to attempt a restoration, though restoration can often be accomplished with only one copy. After the damaged data is corrected in memory, a new tape may be recorded and verified which does not contain the errors. The success rate of **RESQ2** will depend on the severity and quantity of errors. **RESQ2** comes with a comprehensive user manual and examples of two types of 'crashed' programs to practice on.

Specify Model I or Model III. RESQ2.....\$19.95

RAM SPOOLER AND PRINT FORMATTER

This program is a full feature print formatting package featuring user definable line and page length (with line feeds inserted between words or after punctuation), screen dump, printer pause control and baud rate selection. In addition, printing is done from a 4K expandable buffer area so that the LPRINT or LLIST command returns control to the user while printing is being done. Works with cassette or disk systems. Ideal for Electric or other slow printers. Allows printing and processing to run concurrently. Output may be directed to either the parallel port, serial port, or the video screen. 80 Microcomputing said "I can only give my highest recommendation of Spooler and Mumford Micro Systems."

Specify Model I or Model III. SPOOLER.....\$16.95

DUPLICATE SYSTEM TAPES WITH CLONE

Make duplicate copies of almost any tape including Basic, SYSTEM, data lists, assembler source, or custom loaders. The file name, load address, entry point, and every byte (in ASCII format) are displayed on the video screen. Model III version allows changing tape speed so you can load in a tape at 500 baud and write it out at 1500.

Specify Model I or Model III. CLONE.....\$16.95

MACHINE CODE FAST FOURIER TRANSFORM

Written by Dr. A.H. Gray, Jr., co-author (with J.D. Markel) of the classic text 'Linear Prediction of Speech', this complete package includes 3 versions of the machine language FFTASM routine assembled for 16, 32, and 48K machines, a short sample Basic program to access them, a 10K Basic program which includes sophisticated interactive graphing and data manipulation, and a manual of instructions and examples. The machine language subroutines use variables defined by a supporting Basic program to make data entry and retrieval automatic, without PEEKs and POKEs. They perform 20 to 40 times faster than their Basic equivalent (256 points in 12.5 seconds), and handle up to a 1024 point complex FFT. The FFT is useful in analyzing stock market and commodity trends as well as for signal analysis.

Specify Model I or Model III. FFTASM.....\$49.95

FFTASM on disk with source code.....\$69.95

MUMFORD MICRO SYSTEMS

ORDERING: Complete satisfaction is guaranteed or a full refund will be made. All programs except TELCOM and DISK INTASM are shipped on cassette unless \$5 is included for a formatted (no system) disk. Include \$1.50 for postage and handling. California residents add 6% sales tax. Visa, Mastercharge and COD orders accepted. **SPECIFY MODEL I OR MODEL III.** Dealer inquiries invited.

Box 400-E Summerland, California 93067 (805) 969-4557

quickly, and it minimizes the pain of correcting syntax differences.

Missing in the manual is a subroutine map of the run-time system. If you are familiar with Assembly-language programming, you can write a program using all the available ZBasic commands (in simple form) with a minimum of control-passing through GOTOs and GOSUBs, and use a disassembling monitor (such as TASMONT) to look at the calls the compiled program makes to the run-time system. Since you already know the order of the statements in your program, you can determine which routines perform which functions. You may then use these subroutines in your machine-language programs by placing the appropriate values in the appropriate registers and simply calling that routine.

Simutek also thoughtfully included a Misosys program called CMDFILE, a utility with some nice capabilities such as:

appending two or more CMD files or System tapes into one file; offsetting a tape or disk file so it loads into an area other than where it was meant to execute; appending machine-language programs with "patched" code without reassembling the program; single-drive copy of CMD files; and creating System tapes from non-contiguous blocks of memory.

This utility is a useful addition to the ZBasic package. You may optionally keep a loading log sent to the printer for a permanent copy. The main uses in this environment include: downloading a compiled program from disk to tape; and creating merged ZBasic/machine-language programs.

The latter option is especially useful. I created a logo and stored the 1,024-byte screen to disk. Since I wanted to use this screen in my ZBasic program, I needed to load it into memory with the program, although they may not load into contiguous

blocks of RAM. This utility enabled me to easily merge the programs together into a unified whole.

ZBasic 2.0 is a powerful, interactive compiler possessing capabilities beyond those offered by any other compiler on the market. Although it generally requires re-writing of source programs to compile them with ZBasic, the compiler works incredibly quickly, as do the object programs.

High-precision math, disk and tape sequential files, a built-in tone generator, special USR machine-language routines to pass four or six registers, and other useful functions are now available. The manual is much improved and includes many examples of source programs and routines.

Best of all, no royalties need be paid for selling compiled programs. ZBasic 2.0 has my highest recommendation. ■

Gold Plug 80
E.A.P. Company
P.O. Box 14
Keller, TX 76248
\$54.95

by Robert Jacobs

A hhhh, instant relief! At last there is a permanent cure for contact oxidation on Model I edge connectors. Many TRS-80 users are familiar with the symptoms: untimely resets, spontaneous reboots, or the inability to get the computer started at all

without a frustrating session with a pink eraser.

The Gold Plug 80 is a well made device consisting of an edge-card plug with gold plated contacts, available with either 34 or 40 contacts. The rear of the plug has terminal tabs which fit exactly over the existing foil fingers on the TRS-80's connectors. After installation, the original plugs have been extended about a half inch, meaning that the plastic door covers no longer fit. This did not trouble me, but you should take it into consideration. E.A.P.'s advertising leaflet, by the way, cautions you about the doors, which is refreshing. They also have the excellent policy of permitting you to return any plugs ordered for

a refund if after seeing them you are unwilling to undertake the installation.

An excellent set of instructions accompany the plugs, and they are shipped promptly. I ordered mine by mail on a Monday and received my set of plugs by first class mail on Tuesday of the next week.

Installation

Installation requires a soldering iron (I use a 40-watt Weller), Rosin-core solder, a Phillips screwdriver, and your last Pink Pearl. The keyboard and Expansion Interface have to be disassembled to get at the connectors, which are then cleaned—the eraser's last filing. The Gold Plug 80 is fitted over the existing plug with the contacts centered, and then soldered to the board. I have some soldering experience, but it proved to be an easy, safe job. The contact is heated, a very small amount of solder applied, and then you go on to the next contact. It took about an hour to do all six plugs.

If you are a little nervous about this kind of work, note that all the contacts on the underside of the RS-232 output connector are grounded—that is, they are all connected. Start there; you can do no harm and the practice will be helpful.

The Gold Plug 80 set I bought included all six plugs. The plugs are available individually for \$9.95, or you can get a pair for the keyboard to Expansion Interface cable for \$18.95.

As I said earlier, I did resolder every connector on the machine, and I haven't had a single unwanted reset since. ■

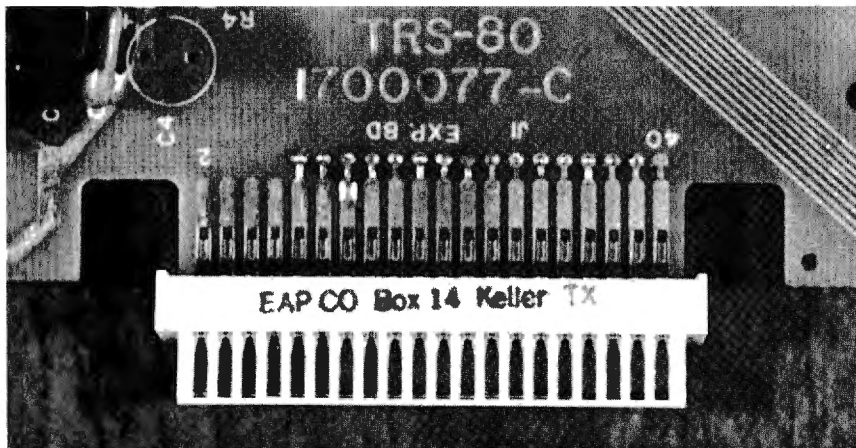

The Gold Plug 80

M-ZAL™

Release Two Is Here!

Our Users asked for it, and we made the best TRS-80 disk assembler even better! Now M-ZAL has:

- Recursive MACROS with full symbolic parameter substitution
 - Conditional assembly with unlimited nesting
 - Text Editor warm-start/recovery option
 - Support for all popular source file formats
 - Load Module inspect/superzap using LINKER
- and the features that made it famous:

- True multi-pass assembly
- Full Screen Option Menus
- ENTRY/EXTERN symbols, relocation, and object module linking
- 8 character labels with sorted symbol table
- Built-in symbol table cross-reference
- Nested *INCLUDES (source file chaining/nesting)
- Lower case support (Model 3 only)
- Over 175 pages of documentation including Z-80 Technical Manual
- Full Screen Text Editing and much, much more!

M-ZAL provides a modular, structured development environment that makes programming your TRS-80 a truly enjoyable experience. Order yours today. (Requires 32k, 2 disk system)

#1050-10	Mod 1	\$149.00
#1250-10	Mod 3	\$149.00

CAU Development Software— The Professionals Choice:

Full Screen Text Editor for BASIC: we were the first to give the TRS-80 this indispensable ability! A must for every BASIC programmer:

#1010-20	Mod 1	\$24.95
#1210-20	Mod 3	\$29.95

T-ZAL: custom designed for the Model 3, this tape based assembler has many of M-ZAL's most desired features.

#1250-20	Mod 3 only	\$49.95
----------	------------	---------

XBUG: for machine language analysis and debugging—this tiny (2.5k) but powerful program lets you do it all!

#1020-10	Mod 1	\$19.95
#1220-10	Mod 3	\$19.95

FILEXFER: transfer any disk file between two TRS-80s. Use direct cable link or RS modems. Mod 1 and Mod 3 can be mixed. RS-232 and disk reqd.

#1040-10	Mod 1 and 3	\$49.95
----------	-------------	---------

"We've been using M-ZAL heavily for over two months now, and it's been worth its weight in gold."

—Chuck Tesler
PROSOFT

"...well written software that is long overdue."

—Bruce Douglass
80 Microcomputing
BASIC Editor Review

"During the first 3 days of use, M-ZAL saved more money in programmers time than we had paid for the product."

—William Denman
Author of Asylum
MED SYSTEMS

"The editor has at least doubled my productive capacity...Having spent a good deal of money on so called 'utilities' that don't work, it's a delight to find one that not only lives up to its claims but surpasses the advertising."

—BASIC Editor user

Our choice for the best TRS-80 DOS:

DOSPLUS 3.4	Mod 1	\$149.00
DOSPLUS 3.4	Mod 3	\$149.00

Call or write for more information.

All products require level II.

Mail orders specify catalog #.

Send check, money order, or MC/VISA numbers and expiration date to:

Computer Applications Unlimited

P.O. Box 214, Dept. ABM Rye, New York 10580

(914) 937 6286

N.Y. State residents add applicable sales tax. Outside USA and Canada add \$7.00 shipping.

Dealer Inquiries Invited.



CAU™ **COMPUTER APPLICATIONS UNLIMITED**™

a div. of CAU, Inc.

120

TRS-80 is a TM of Tandy Corp. M-ZAL is a TM of CAU, Inc. Z-80 is a TM of Zilog, Inc.

Mod II Games
Lance Micklus
Small Business Systems Group
6 Carlisle Rd.
Westford, MA 01886
\$75

by Paul Grupp

The fact that you own Tandy's most expensive business machine doesn't mean you shouldn't be able to play computer games every now and then. Many a Model II owner has turned green with envy watching a lowly Model III hacker zapping Klingons and docking at the star base. Let's face it—Mod II owners are people too, and there is nothing like a good computer game to reestablish friendship with a dull business machine.

Small Business Systems Group has had an excellent package of Model II games available for some time now. Their plan was to make some of the more popular types of games available to the Model II user, rather than produce super games taking advantage of the Model III's unique speed and memory capabilities. If you bear this in mind, you'll find the package very satisfying. Written by Lance Micklus, it includes Star Trek, Checkers, Concentration, Treasure Hunt, Banko and Dog Star Adventure. The Star Trek game is a superior example of the genre, demanding both strategic planning and tactical know-how. It is complicated enough to be absorbing, but not so demanding that it is boring. I started playing it at seven o'clock one evening, and when I came back to earth, it was five in the morning!

Dog Star Adventure also rates as a top game. Even a jaded computer adventurer will find those dastardly twists and shocking surprises entertaining. Banko is essentially a Black Jack game, with the computer as a dealer playing to win.

The remaining games on the disk I can live without. The programs are written well, but I can't get excited about Checkers and Concentration under any circumstance. Others may enjoy them immensely. All the programs were well documented, and contained no bugs or glitches.

The package is reasonably priced for the number of games included, and is well worth buying to have around the office for those moments when business is slow. Many who have spent hours grinding out accounts receivable and statistical analyses may never have had the experience of playing a good computer game. To them this Lance Micklus package can be a real eye-opener! ■

New! Greymoon



Greymoon is the medieval land in which this simulation of conquest and economic development takes place. As creator of Greymoon, you can buy, sell, plant, feed, hire, build, raid, invade, and consult various advisers. Objectives? Gain land become wealthy, develop your initial small village into a city state and increase your rank from master to King. Obstacles? Every year brings one of over a dozen random events, which, until the end of year, are unknown to you except through hints by your advisers. Can you compete with the many neighboring nations of Greymoon?

Even has sound routines. It will keep you interested for hours on end. Each game is different. The game is very fast but you can play at your own speed. All ages will like it and it takes no special skills but a sharp mind. This is better than an adventure game in the fact that each game is different and is more realistic.

TRS-80 Model I or III
 16K Tape \$17.95 Disk 18.95

TOP TEN GAMES

1. ALIEN DEFENSE (Soft Sector Marketing) 15.95/19.95
2. SCARFMAN (Cornsoft) 14.95/18.95
3. COSMIC COMMAND (Big Five) 19.95/19.95
4. DUNGEON ESCAPE (Computer Shack) 14.95/19.95
5. GALAXY INVASION (Big Five) 14.95/19.95
6. DEFENSE COMMAND (Big Five) 14.95/19.95
7. ROBOT ATTACK (Big Five) 14.95/19.95
8. LASER DEFENSE (Med Systems) 14.95/19.95
9. ELIMINATOR (Adventure Inter) 14.95/19.95
10. GREYMOON (Computer Shack) 14.95/19.95

We have a panel of expert game players who will give a monthly rating of the best games on the market. It will change monthly, so keep looking each month. Games with a price after them are carried by us and can be ordered. Games without prices are not stocked by Computer Shack.

- Other games that we carry that are not in the top ten.
- SPACE CASTLE (Cornsoft) 15.95/19.95
 - SUPER YADERS (Soft Sector) 15.95/19.95
 - FORTRESS (Soft Sector) \$15.95/19.95
 - FORBIDDEN CITY (Fantastick) 39.00 disk
 - VOYAGE OF VALKYRIE 34.95/38.95
 - 80 SPACE RAIDERS \$24.95 tape only

Programmers Wanted

We are looking for some exciting new programs to aggressively market. At Computer Shack we work with our programmers. We can tell you what to write, guide you and help you. We make sure you are paid for your efforts.

Have you ever sent in a program and had it accepted by a company and received your first check 6 months to a year later. We pay a deposit to you on acceptance of your program. We will even buy, your program, outright giving you a large check at once, if you would rather have this then a royalty check every month.

COMPUTER SHACK

1691 Eason
 Pontiac, Michigan 48054
 (313) 673-2224 • (313) 673-8700

New! Baja



Take your dune buggy and enter it in the famous Baja Desert race. The race has straightaways, curves, S's, and obstacles. We feel that this is the best car race game made for the TRS-80.

The game has 10 different action packed skill levels. The program is all machine language for fast graphics and excellent sound. 1 to 6 players.

TRS-80 Model I or III
 16K Tape \$15.95 Disk \$18.95

Dungeon Escape

At last! An adventure which takes quick thinking and strategy! Different from fixed adventures.

- ★ Super graphics ★
- ★ Interactive Sound ★
- ★ Fast Paced
- ★ Uses latest programming techniques ★

the creator's ghost has sensed an intruder, and he is determined to hunt you down. His intelligence in tracking was set by you. This feature makes this simulation unlike others for you're always "on the go."

★ Written by an experienced gamer in fantasy role-playing, based on the game Dungeons & Dragons.

Objective: Your character begins on the first of a three level dungeon, searching for magical "stones" which permit you to descend to the next lower level!

The Adventure: There are numerous traps, and over a dozen hostile monsters that come in various sizes, shapes and degrees of nastiness. It has various treasures and magic items (weapons, elixirs, cloaks, scrolls, etc.) You can become a fighter, a thief or a magic-user. Each time you play you get a totally different and exciting game.

This short description only begins to tell you of the many adventures and some of the textures of this exciting game. This will be your favorite adventure game!

Complete documentation included.
 You must specify Model I or Model III. Available on:
 Tape, 16K \$19.95 Diskette, 32K \$19.95

WARZONE

A new game that pits you against the computer. Trying to isolate the computer before he stops your conquest. Exciting sound routines and great graphics. This is a fast paced game that is excellent for young and old. It has three skill levels.

Tape \$14.95 Disk \$18.95

Modem Games

Play CHESS, CHECKERS, and OTHELLO over your modem with your friends! Each game features full graphics, sound, and a chat mode permitting you to send messages and sounds. Games are for two players and can be played on one computer or over the modem on two computers. All three games are on each program, comes with 2 disks or 2 tapes. You must each have a Modem Game program to play over the modem. Share the cost with a friend. The same version of Modem Games will work on both the Model I or the Model III disk or tape. Modem games will work on only the Lynx modem or modems using a 232 board.

2 Tapes or 2 Disks \$29.95

MINE FIELD

This game is played with a friend over the telephone, and features full graphics as well as a terminal mode for chatting before the game. In Mine Field you and your friend set up a maze of mines that you will try and get thru to win but if you hit a mine then it's your friend's turn to try. At the end of the game the maze you set up will be sent to your friend and his to you so you may view where you went right or wrong. To run this game you need at least 32k memory and rs232 w/modem for lynx. You get two programs and two sets of instructions (1 for you and 1 for your friend, share the cost!) 2 Cassettes \$35.00 (can be loaded to disk) or \$43.00 for two diskettes

COMPUTER SHACK

MULTI DOS

We sell them all --- We recommend and use **MULTI DOS** --- Don't let its low price fool you. It'll do everything the others will and quite a few things they can't. -

MULTIDOS has the **BEST BASIC** -- it's the **EASIEST** to use and it's the **FASTEST** system around. For more details see Cos. Electronics full page ad in this magazine. Why pay twice as much for an operating system that's complicated and hard to use.

SPECIALS

MULTI DOS with Aerocomp Doubler \$209.00
 MULTI DOS with Super Directory \$99.00
 MULTI DOS with Super D & Doubler \$229.00
 DOS PLUS 3.4 \$129.00
 L DOS \$119.00
AEROCOMP DOUBLER \$139.00

The operating systems that are given out free with the doublers for \$149 and \$159 dollars are not comparable with all of the features of Multi Dos.

Look what you get with Multidos Basic!

A file handling utility sold separately for **\$19.00**
 A graphics program sold separately for **\$19.00**
 A Gobal editor sold separately for **\$19.00**
 Boss debugger single stepper sold separately for **\$19.00**
 you get all this plus the best basic for only **\$79.00**

We, at Computer Shack have been asked if Multi Dos is as good as the other Dos's selling for \$150 and up. I can honestly say that for 90% of the people using TRS-80's Multi Dos is the best dos you can buy at any price. If you are a professional programmer you would probably like Ldos and/or NewDos 80. These operating systems can do some things in machine language programs that Multi Dos cannot do, but they do this at the sacrifice of simplicity. Both of these systems were written by professional programmers for professional programmers. They are both very complex systems, and they are very difficult for most people to use. Multi Dos's basic is by far the best on the market

We could make twice as much money selling you a copy of Dos Plus 3.4 at \$149.00 but why should you spend that much for a system that won't do as much as Multi Dos will for \$79.00.

We recently asked some of our programmers what they thought of Multidos. Bill Dunlevy author of Dungeon Escape and Greymoon said "I am a programmer who values my time greatly. When I sit down to program, I wish to program, not dig through manuals or have unexpected things happen. MULTIDOS is an operating system which provides maximum results with minimal effort. Having a global editor, a graphics mode, and various other aids available at the touch of one or two keys is extraordinarily helpful in program production, debugging, and efficiency. I will never give up the versatility offered by MULTIDOS"

Gordon Monner Owner of two small business's and the author of Small Business Checking and Billing programs said, "I own New Dos 80 and Dos Plus 3.4 along with Multidos. I use Multidos exclusively on both the Model I and the Model III. I have found Multidos to be more dependable, faster, and easier to use than the other two systems. MultiDos is oriented to the average user. The biggest thing is, that I can use it without constantly referring to manual and every program that I have will run on MultiDos without any alteration. Multi Dos is the ideal dos for a Business Man who wants a easy to use yet high powered operating system. Multi Dos is much more user friendly (easier to use) than any other dos on the market. It also has more features for the basic programmer than any other dos on the market.

Mark Feldman author of Super Directory, a Machine language directory program. "I used Dos Plus until I received my copy of

Multi Dos. Now I use Multi Dos all the time. Multi Dos is faster and more user oriented than any other system I have seen. The Directory is the key to all of your disks and Multi Dos can do more with the directory than any other system. It's copy routine is faster and better than Dos Plus's. Its VFU utility is worth the price of the dos alone. It is the only dos that can read or write to all of the other major dos's. I couldn't have written my Directory program without Multi Dos's ability to read the different Directory's. Multi Dos can do more with graphics than any other system. It can pack graphics, list packed graphics in a basic program, print graphics characters from the keyboard and even screen dump them to the printer in either standard mode or Epson mode

Multi Dos is not a cheap copy of other operating system's. It is a new Dos specially written for the average TRS-80 user. Listed below are some of the features that Multi Dos has that most of the other dos's don't have. This list has 34 things that would be commonly used by most people. 20 are exclusively Multi Dos.

Repeat's last dos command. Multiple dos command. Hi Speed boot, nested Do file, software powerup, hi speed debug, executable debug, alphabetized directory, forms command, totals free, keyboard attributes, topmen, auto-multiple density recognition, copy only if sufficient space, graphics driver, single step basic, zero arrays, delete arrays, sort routing, used variables and their values displayed, transfer to level II, find, intelligent global editor, string packer, line splitter, line merger, renumber to line 0, renumber packed strings, lists graphics, automatic high speed, won't hang if no printer, repeating keys, menu driven copy to file, screen dump graphics to printer.

These are the features that other dos's are spending thousands of dollars and hundreds of hours trying to copy (this is a quote from another company's ad that has 6 of the 34 features listed above).

FAMILY TREE

Excellent family genealogy program works on both the model I and III. Written especially for the person just getting into genealogy. It has over 250 pages of instructions on how to research your family tree, how to get information, and how to put it into the program. The computer program is easy to follow and gives both printouts and screen listings of your family tree. It will even give you a listing of all your living relatives birthdays

Disk or Tape \$29.00

SUPER DIRECTORY

This will be the standard which all other Directories are judged. It will read any normal type of diskette Model I or III, Multi Dos, Ldos, Dos Plus, and Trs Dos. Double Density, Single Density, 35, 40 or 80 track drives.

A machine language program that is easy to use, but at the same time has all the features you will ever need. Display to screen or to printer. Displays by program, or disk, or subject. Super fast sort. Scrolling displays, ect.

You can even add a file to help tell what the program is about Example:

SARGON/CMD 146G GREAT CHESS GAME
 SARGON/CMD is name of program read off of disk. 146 is you reference number for this disk G is added later designating game "GREAT CHESS GAME" is added later as a descriptor file.

Special Introductory offer with each directory ordered before July 1st we will include 4 blank Wabash® double density Disks for a dime or you can get a box of ten disks for only \$19.90 Please specify Model I or III and if you have a doubler.

Super Directory \$39.90
 Super Directory with 4 Wabash Disks \$40.00
 Super Directory with 10 Wabash Disks \$59.80

Hayes Smart Modem

We at Computer Shack think this is the best modem on the market. We include a file transfer and communications program at no charge with each purchase of the Smart Modem.

Programs and modem only \$259.00

Super Spooler

An intelligent printer interface releases your computer from the mundane task of printing. With up to 62k of internal memory, an internal microprocessor, and many intelligent features, the Super Spooler is the ideal addition to any computer system that ties up the CPU for printing.

With Super Spooler installed, only seconds are required to send even a lengthy text file to your printer. Sooper Spooler accepts the data at up to 3000 characters per second and stores it in it's own memory bank. You can go on using your computer for more profitable activities while Sooper Spooler continues to feed data on your printer.

For example with a 80cps printer it takes 21 min. of CPU time to print a 20 page report. With Sooper Spooler it takes only 16 sec. of CPU time

The New Super Spooler..... \$329.00

SUPERMETER

The biggest problem in loading tapes has been the volume control. Pre-recorded tapes are produced at differing volume levels. Now finally, a device to let you set the correct volume levels for loading any tape. You will now load any tape the FIRST time. **SUPERMETER** plugs in (no cutting or soldering) between your tape recorder and the computer and lets you set the volume to the level that your computer wants.

SUPERMETER \$29.00

THE TWO YEAR DISK'S

All Wabash Disks are certified 100% error free for two years by the manufacturer. If you have any problems return them to us for new ones

5 1/4 single density \$25.95
 Double Density 40 or 80 tracks \$32.99
 Double Density two sides \$35.99
 8" Disks \$35.99

Small Business Programs

CHECKING ACCOUNT Mod. I or III, 48k disk \$39.00
 Excellent check writing program for small business. Prints checks on printer, sorts into 32 categories for bookkeeper and IRS

BILLING SYSTEM Mod. I or III, 48k disk \$39.00
 Excellent system for the small businessman. It is fast and easy to use. Prints out invoice and monthly bills. Adds interest etc.

SPECIAL BOTH PROGRAMS \$65.00

INVOICE PROGRAMS

Prints out invoice with your name at the top on 8 1/2 X 11 paper

DISK ONLY \$24.95

EP-SET-80

If you have a EPSON Printer you need EP-Set. A series of programs that help you use all the features of the Epson printer. One merges with a basic program to help drive the printer. One is a machine language subroutine to give you keyboard access to the printer. (example type control c to get the compressed mode Control E to get emphasised characters). Use EP-SET to set the line spacing, character modes, strike modes etc. Throw your manual away. Happiness is here with EP SET

Disk or Tape 18.95

ORDERING INSTRUCTIONS:

MC and VISA OK please add \$2.00 for Shipping in U.S.A. Also to help us send you the best possible version include the type of computer you have, your operating system if disk and if you have a doubler in the model I.

DEALERS... Write for our catalog and price list.

COMPUTER SHACK

1691 Eason • Pontiac, Michigan 48054
 (313) 673-2224 (313) 673-8700

Cheaptalk
Alan Saville
 P.O. Box 5190
 San Diego, CA 92105
 \$19.95

by Bruce Powell Douglass

It occurred to me, if I can output tones as a square wave, why not voices? I have already written sound and music routines. Once I figure out how to code the tones, the rest is the same—output through the cassette to the ubiquitous amplifier.

I made a number of false starts and gradually the project made its way to a back burner. An ad for a program called Cheaptalk revived my interest in the project.

Cheaptalk comes with three programs. The first is a machine-language routine to output the sounds through the cassette port. The second program is a Basic driver routine to read bytes in memory and display them (while pronouncing the hex

names). The verbal output is limited to the numbers and letters in the hex number system. The letters are output as phonetics for clarity. The third program allows you to encode speech using hardware that Saville explains how to make. The routine is easy to write, essentially doing what ROM normally does when it reads tapes, except here you shorten the timing loops.

The voice is extremely raspy, but usually intelligible. The words zero, one and six are easy to understand. Several words just do not make it, however. These include Charley (for C), three, eight, and fox (for F). I worked two years as a dispatcher and I had to understand raspy, hard-to-understand voices. Cheaptalk is difficult for me to understand.

Creating your own words requires a hardware modification—nothing much, just a simple A/D converter. Saville provides instructions for two methods. Saville uses a direct A/D conversion, a method I abandoned as requiring too much memory. One requires you modify

the keyboard itself. For the other you build an external device to connect to the expansion interface port or to the keyboard expansion port. Instructions also show

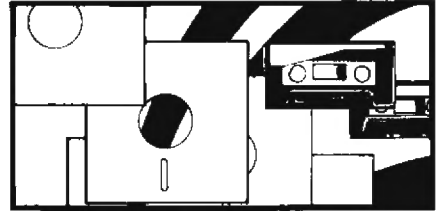

how to modify the tape recorder for use as a microphone for inputting speech.

Although the package is not expensive, I cannot recommend it. The quality of tone is too low and the A/D encoding takes up too much memory, using 512 bytes per second of speech. A 10-word vocabulary would take full 5K of storage! Cheaptalk is a good idea, but needs to have a better encoding technique to allow for better resolution of voice tones and take less memory. ■

Video I
Archbold Electronics
 10708 Segovia Way
 Rancho Cordova, CA 95670
 Model I
 \$24

by Howard L. Walker

The Video I reverse video modification kit is a reasonable monitor enhancement for the price. The kit includes two preassembled PC boards, two resistors, one zener diode, a double-sided adhesive pad, hookup wire and solder. One PC board mounts inside the keyboard housing and the other inside the video monitor.

Assembly

After laying the keyboard face down, I removed the six screws in the rear cover. I turned the keyboard over and removed the cover. I set aside the white spacers between the keyboard and the CPU, and placed both boards carefully on the work mat.

I cut, stripped, tinned and soldered eight wires, varying in length from five to seven inches, to the indicated pads in the kit PC board. I had to cut one PC trace on the CPU.

I placed the CPU in the lowercase housing, installed spacers, and attached the

small PC board to the CPU with a piece of double-sided foam tape. I soldered the eight wires coming from the kit PC board to the CPU. After setting the keyboard in place, I replaced the cover.

Next came the video monitor. I put it face down and removed the bottom and rear covers. I extracted the video interface card and examined two resistors already in the card. Since they were the correct value for the modification, I did not use the two resistors in the kit. However, I replaced one resistor with the zener diode from the kit. I reinserted the interface card and turned my attention to the remaining PC board in the kit. I cut, stripped, tinned and soldered four five-inch wires to the kit PC board. I laid the monitor on its side and removed one resistor from the main board. I attached the four wires, and fastened the circuit board to the underside of the monitor board with a piece of adhesive pad. I finally reassembled the monitor.

After hooking up the interconnecting cables, I crossed my fingers and turned on the computer. The video display came up normally, white on grey. I typed X = INP (2) and pressed Enter. The screen background lightened and the print became black. I then typed X = INP (1) and pressed Enter—the display returned to normal. I ran the test listing in the instructions to check for display linearity and found no distortion. In case of distortion (or "tear-

ing" of the edge of the display), the instructions suggest decreasing a resistor on the video interface card.

The instructions state, "X = INP (2) will reverse video and X = INP (1) will display normal video." However, other input values cause a similar change.

The address decoder scheme is non-absolute: address bits A7 and A5-A2 are not used in the decoding scheme. Any eight-bit address with bit 7 (A6) low and bit 2 (A1) high causes a reverse video condition. Whenever bit 7 (A6) goes high, the decoder circuit logic remains unchanged. A high on bit 1 (A0) and a low on bit 7 (A6) will decode and switch to normal video.

In the reverse video mode, dot data from Z30 in the video mixing circuit is fed into the reverse video board, inverted, and fed into Z41. Z41 then reinverts the dot data (it goes high). This results in a light background and black character dots.

One Little Problem

The kit was easy to assemble and install. The only problem I found was in the operation section of the instructions. Pressing keys 7, 8 and 1 simultaneously is supposed to produce normal video, while keys 7, 8 and 2 should give reverse video. This function does not operate on my unit. I suspect it works in the Level I unit—the instructions show a keyboard without the satellite ROM board, the obvious modification in Level II. ■

HAPPINESS IS...NEWSSCRIPT™

THE WORD PROCESSOR FOR BUSINESSMEN AND PROFESSIONALS

We offer you ongoing support by answering your questions and providing reasonably priced enhancements.

A FEW OF NEWSSCRIPT'S STANDARD FEATURES:

- *Form Letters with merging of names and addresses
- *Gives superb appearance to your final documents
- *Comprehensive manual with hundreds of examples
- *Centering, top/bottom titles, indents, pagination
- *Underlining, boldface, double-width, italics
- *Sub-scripts, super-scripts, proportional pitch*
- *Generates Table of Contents, sorted Index
- *Allows block graphics, special symbols†
- *Search and replace globally or within a range
- *Block move, copy, delete, insert from other file
- *AUTOSAVE, WHOOPS, DIRECTORY, KILL, REPEAT
- *Based on IBM's "EDGAR" and "SCRIPT" systems
- *Supplied ready-to-run on "tiny" DOSPLUS
- *Easily transferred to NEWDOS, NEWDOS/80, LDOS, TRSDOS
- *Includes handy Quick Reference Card

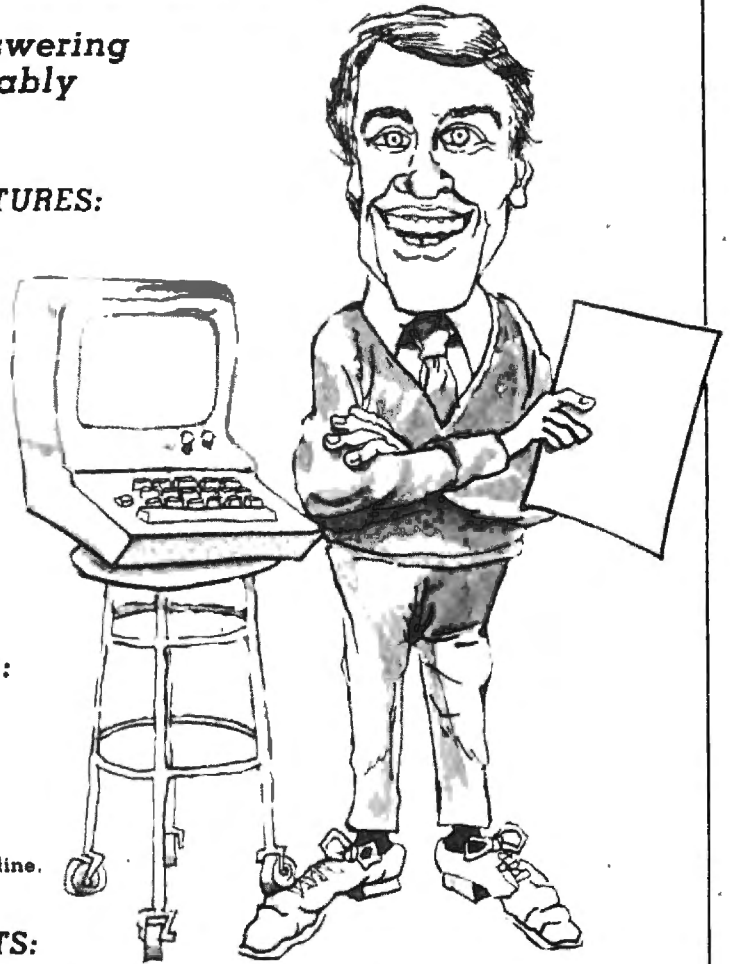

NEWSSCRIPT CONTROLS THESE PRINTERS:

- *EPSON MX-80, MX-100: all 12 fonts, plus underlining and block graphics; italics with GRAFTRAX
- *Centronics 737, 739; Radio Shack L.P. IV, L.P. VIII, Daisy Wheel II, NEC PC-8023A, TEC 8500R, C.ITOH 8510 Right-justified true proportional printing (leading)
- *Good support for: Diablo, Spinwriter, Starwriter, QUME, Microline, Anadex, modified Selectric

TYPICAL USER AND REVIEWER COMMENTS:

the manual:

"It definitely rates the first '10' given to any documentation reviewed in this column." (A.A. Wicks, *COMPUTRONICS*, October, 1981)

the software: "An excellent Word Processor" (D.H.); "Absolutely fantastic" (S.E.S.); "You have features that I cannot duplicate on my \$14,000 system" (J.B.)

the support: "Your phone information system and the prompt and courteous staff that you provide to help your clients...are worth the cost of the system." (V.H.H.)

REQUIRED CONFIGURATION: 48K TRS-80 with one disk drive. Specify Model I or Model III.

† Some features work only if your printer has the mechanical capability.

NEWSSCRIPT:	\$99.95
MAILING LABELS OPTION:	29.95
Special: NEWSSCRIPT + LABELS:	139.95
"PENCIL" to NEWSSCRIPT Converter	14.95
Manual Only (180 pages):	30.00
Reference Card Only:	1.50
MICROPROOF + CORRECTION FEATURE:	149.95
Full DOSPLUS 3.4 Operating System:	149.95

TO ORDER, CALL NOW, TOLL-FREE:

(800) 824-7888, Operator 422
 CALIF: (800) 852-7777, Oper. 422
 ALASKA/HAWAII: (800) 824-7919
 FOR TECHNICAL INFORMATION CALL:
 (213) 764-3131, or write to us.

Order from your Software dealer, or from:

PROSOFT™

DEPT. C, BOX 839 • NO. HOLLYWOOD, CA 91603

TERMS: We accept VISA, Mastercard, checks, Money Orders, C.O.D. and even cash. We pay shipping via surface UPS inside U.S.A. Please add \$3.00 for Blue Label, 6% tax in California, and 15% outside North America (air shipment).

Microline 82A
Okidata Corporation
111 Gaither Drive
Mt. Laurel, NJ 08054
\$499-\$879

by Ed Thomas

With the improved print quality and reduced cost, today's line printers are looking more and more attractive to both the home and small business computerist. I finally decided it was time to upgrade my lowly Model I, 16K TRS-80 with this very useful peripheral—my manual typewriter was just too slow with me as the interface between Scripsit and a printout. The only question I had was which printer? After scanning vast amounts of literature, I decided on the Microline 82A.

The Okidata Microline 82A is a fantastic little printer which I believe is superior to anything in and around its price range, realizing that each one of us have different criteria for evaluating the value of a printer.

Cost

I bought mine for \$499 plus postage. I have seen the list price as high as \$879, so it pays to shop around. Interfacing the printer can be done in either serial or parallel. I chose to invest in a 32K Expansion Interface and use a 36-pin cable rather than just a printer expansion cable. The place where I bought the printer extracted several pins to make it compatible with the TRS-80. This can be easily done yourself since the manual informs you how the pins are arranged for both serial and parallel interfaces.

One thing that is often forgotten is the cost of maintaining the printer—here is

where the Microline 82A shines. First, its print head is rated at 200 million characters. Replacement costs about \$143

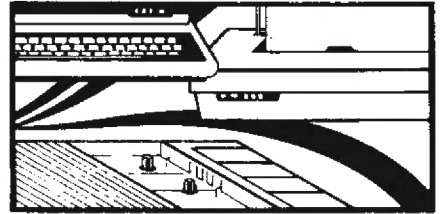

(which compares well with Epson's disposable print heads costing \$30-\$40, and rated only at 50 million). Second, the printer uses a \$38.40-per-dozen ribbon on a spool rather than the often messy \$14.95 mobius ribbon. Though the mobius ribbon is rated at three million characters and the Okidata ribbon is only rated at 1.5-2 million characters, there is still an impressive savings with the Microline 82A (see cost chart). Having experienced no difficulty with the printer, I do not have any information regarding various service charges.

Features

The printer measures 14.2 inches wide by 12.9 inches deep by 5.2 inches high. It weighs 19.9 pounds and the case is made of aluminum. Its nine-pin print head prints at an impressive 120 characters per second. To increase its speed, the printer is both bidirectional and short-line seeking.

Pinfeed and frictionfeed are standard but a tractorfeed option is available for \$50 (a roll-paper stand is also available). The paper (8.5 inches wide, single sheet or roll, or 9.5-inch wide sprocket) may be fed from the rear. If you use sprocket paper you can feed the paper in from the bottom. There is a knob to advance the paper manually, a tear bar, and a wire guard to separate the paper entering the printer from the paper leaving the printer.

The controls on the front panel allow you to select form length (also software controllable), set the top of form, select/deselect (on-line with computer or under local control), form feed, and line feed. There are three lights which indicate select/deselect, out of paper, and power on. If you keep the line feed switch depressed while turning on the power and then release the line feed, the printer generates a self-test.

An access cover allows you to align the paper, change the ribbon, or adjust the distance between the print head and the paper (handy when using four sheets instead of just one). If you remove the entire case (which is not very difficult) you can access eight dip switches on the front

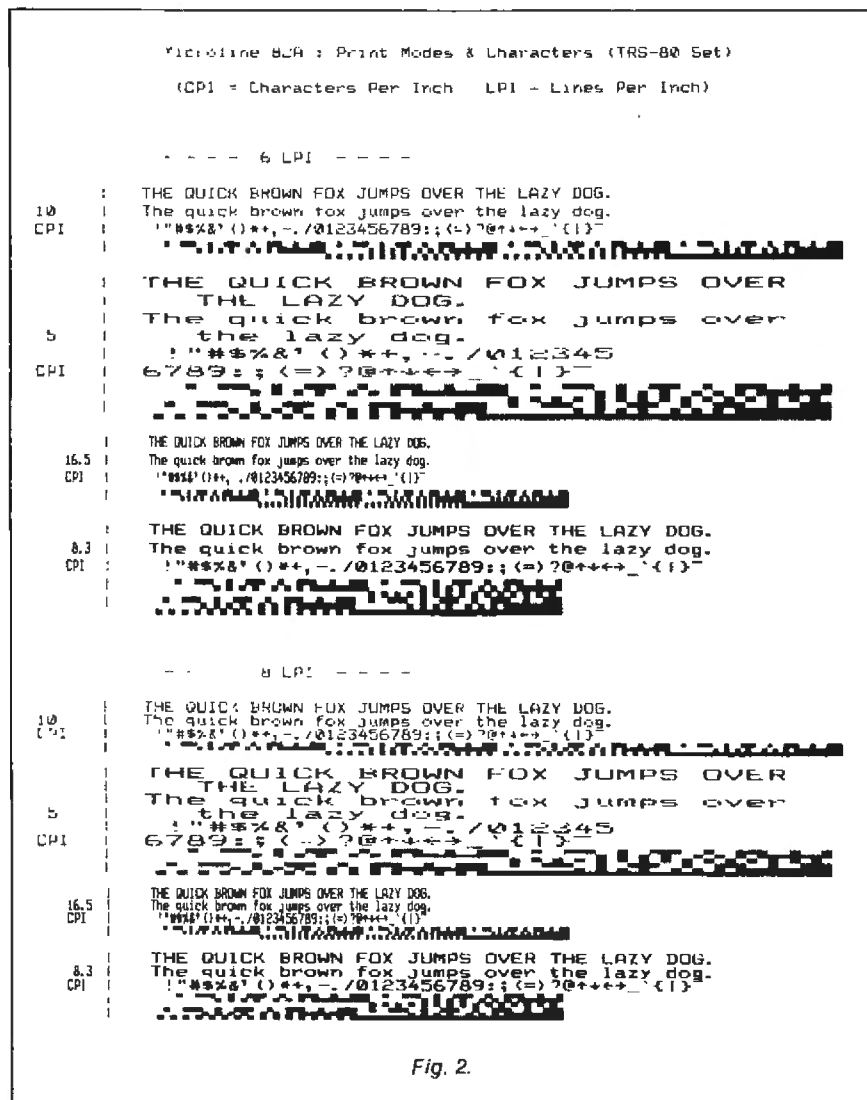

Fig. 2.

Comparing 82A and MX-80FT

Assume 300 million characters and no service charges

82A	\$499	MX-80FT	\$585
Tractor	\$50	(included)	
Cable (59 w/o EI)	\$29	Cable (90 w/o EI)	\$29
1 new print head	\$143	6 new print heads	\$210
(installed & postage)		(installed & postage)	
204 Ribbon Spool @ \$38 40/doz.	\$653	100 Ribbon @ \$15	\$1500
Total	\$1374	Total	\$2324

Fig. 1. Cost Chart

panel. These switches can select either parallel or serial interface, one of 10 character sets, an optional character set, and other printer control codes. In addition to the dip switches there are the short plugs, a fuse, and a circuit breaker.

The nine-pin head generates a very good correspondence print and can be software controlled to print at 16.5, 10, 8.3 or 5 characters per inch. Line spacing is under software control and can be set at six or eight lines per inch. (Lowercase descenders are lost at eight lines per inch.) As mentioned before, it is possible to select by the dip switches any one of 10 different character sets (ASCII, TRS-80 and various European sets). Though

TRS-80 graphic blocks are supported, dot-graphics are not. It is not possible to over-strike or proportionally print each character to fill in the dot matrix. Another characteristic of this printer is that you can use 10 and 5 cpi or 16.5 and 8.3 cpi on the same line. You cannot, however, use any other combinations on the same line. See the print sample of the various cpi and lpi the Microline 82A generates (Fig. 2).

The Manual

The manual is not a self-study guide, but rather a bare bones approach to the basics. The pictures are helpful but there is a great lack of examples which illustrate how to utilize the printer's many fea-

tures. The troubleshooting section is a nice thought, but is rather brief and often a statement of the obvious.

Regrets

The dip switches could have been more accessible for easier and quicker changing among the various character sets. I have also found that the j is not printed as indicated in the test pattern included in the manual—I would have preferred to see the j dotted. The ability to use more combinations of the various print modes on any given line would also have been nice.

A more serious problem is the manual knob for advancing the paper. I have been using only single sheets and have found that the knob tends to pull the paper unevenly. One last comment is that I would like to see Okidata come out with a self-study guide (I believe Epson has done this for their MX-80). Such a guide would be very helpful for novices like myself who would like to use all the features of their printer.

I am delighted with my Microline 82A. It is fast, loaded with features and economical. ■

Novell Image 800 Printer
Novell Data Systems
1170 North Industrial Park Drive
Orem, UT 84057
\$1,395

by Ronald Beauchemin

Locating the most cost-effective and reliable printer in the 150 cps range for your TRS-80 can be an arduous task for the professional and novice alike.

The printer I selected was the Novell Image 800 Dot-Matrix Printer. The manufacturer and the printer itself are probably

unknown to most microcomputer users because the printer has been marketed primarily to the Fortune 1,000 corporations and other medium to large-scale data processing installations. I became aware of the printer through literature I received as a computer systems analyst for a multi-national corporation. I requested further information about the printer from Novell.

After analyzing the specifications of this printer and others, I decided on the basis of cost and specifications that the Novell 800 was my best choice for my TRS-80.

The first step in my evaluation was determining if the printer could be properly interfaced to the TRS-80. I felt the printer should be plug compatible with the TRS-80 since it was available with a Centronics parallel interface.

The printer was delivered from a previous evaluation in which it was attached to an RS-232 device. I had the opportunity to use it in both the serial and parallel modes as I had a parallel to serial conversion device which operated at 300 baud. It worked well in the serial mode although this was not the configuration in which I had intended to operate the printer.

Installation of the parallel interface

```
THIS LINE IS PRINTED AT 10 CPI. STD. WIDTH. STD. DENSITY

THIS LINE IS PRINTED AT 13.6 CPI. STD. WIDTH. STD. DENSITY

THIS LINE IS PRINTED AT 16.5 CPI. STD. WIDTH. STD. DENSITY

THIS LINE IS PRINTED AT 10 CPI. STD. WIDTH. DOUBLE DENSITY

THIS LINE IS PRINTED AT 10 CPI.
DOUBLE WIDTH. STD. DENSITY

THIS LINE IS PRINTED AT 13.6 CPI.
DOUBLE WIDTH. STD. DENSITY

THIS LINE IS PRINTED AT 16.5 CPI.
DOUBLE WIDTH. STD. DENSITY

X2 = A + B    THIS LINE CONTAINS SUPERSCRIPING
X2 = A + B    THIS LINE CONTAINS SUBSCRIPING

THIS LINE HAS 10 CPI SINGLE AND DOUBLE WIDTH AND SINGLE AGAIN
THIS LINE HAS 13.6 CPI SINGLE AND DOUBLE WIDTH AND SINGLE AGAIN
```

Table 1. Novell 880 Printing Sample

board required no electronics ability at all. Anyone with common sense and the ability to handle a screwdriver could easily complete the installation in less than 20 minutes. (If a printer is ordered with the parallel interface this procedure is not necessary as the board is already installed.)

My first step was determining the proper cable to connect to the printer. The standard Radio Shack printer cables were 100 percent compatible. The Model I with the Expansion Interface and the Model III use cable number 6-1401. The Model I without the Expansion Interface uses cable number 26-1411 while the Model II uses cable number 26-4401.

With the proper cable installed, I had to make the following choices:

“The Standard Radio Shack printer cables were found to be 100 percent compatible.”

- 80 or 136-column format
- Standard or optional character set
- 11 or 12-inch form length
- six or eight lines per vertical inch
- Insertion of line feed after carriage return
- Serial or parallel interface installed
- Accept carriage return for further processing
- 10 cpi standard density
- 13.6 cpi standard density
- 10 cpi double density
- 16.5 cpi standard density

For my particular application, I chose:

- 136-column format (15 inch wide paper)
- Standard character set
- 11-inch page length
- eight lines per inch
- Insert line feed after carriage return
- Parallel interface
- Accept carriage return for further processing
- No automatic advance at end of page
- 10 cpi standard density

Once the configuration (dip switch selectable) was completed I began the actual printing test. The print quality produced by the 9 by 9 dot matrix was excellent on forms ranging from stock, one-part, continuous-form, to thick continuous-form mailing labels.

The print quality is maintained by an adjustable print head allowing reliable print-

ing of one original and up to four copies (15-pound original, 12-pound copies with 7-pound carbon).

Additional printer features simplify the programming and day-to-day operation of the printer.

One of these features is automatic page advance, allowing the programmer to print Basic programs using LLIST without having the listing printed across the perforated edge of the page.

Another very helpful feature is the ability to change character width and density via program control. This lets you change to any one of seven print types at any time, including changing the width within the same lines. This is accomplished by imbedding a control character within the print data. The print types allowed by this

feature are 10 cpi, 13 cpi and 16.5 cpi in both single and double width. In addition is the availability of double-density printing at 10 cpi. This option reduces print speed by half since each character is over-printed once. The print quality obtained from this mode is as good as the print from a line printer using a print train.

Equally as important as the ease of programming is the ease of operation. The step button allows for easy alignment of forms by advancing the paper vertically in 1/48-inch increments. In addition to the step button, the form-feed button allows the operator to advance the paper a page at a time.

Once the forms are aligned and the printing begins the operator needs only to check on the printer periodically. For this reason it was imperative the printer have paper-out detection and off-line capability.

The paper-out detector prevents the printer from printing once it runs out of paper. It also sends a printer-busy signal to the CPU so data is not lost.

The off-line capability is also important as it allows the operator to halt printing to check the alignment or progress without losing any data. A printer-busy signal is sent back to the CPU in this instance also.

The ability to expand the buffer to 3,300 characters works in conjunction with the off-line indicator to some degree. The off-line indicator and the buffer are related since a printer-busy signal is not sent to

the CPU in the off-line mode until the buffer is full.

The standard buffer for the Novell 800 is 300 characters. I requested the six IC sockets for the additional buffer memory be installed at no extra cost allowing me to expand the buffer on my own without voiding the manufacturer's warranty.

By installing my own buffer memory I saved in excess of \$250 on the price of the printer. The buffer memory consists of two 2114 static RAM chips for each 1K buffer increment to be installed. Novell charges \$100 per 1K of buffer memory. The two chips may be purchased at Radio Shack (part # 276-2504) for \$7.98 each.

Once you have purchased the chips the installation is easy. Only three rules must be followed:

- The chips must be installed in pairs.
- Pin 1 orientation must be observed (match the indentation in the IC to the cutout in the socket).
- The pairs should be installed as follows:
 First Pair—socket U25 & U30
 Second Pair—socket U26 & U29
 Third Pair—socket U27 & U28

This additional buffer memory is helpful since the printer sends a printer-busy signal to the CPU only after the buffer is full. Extra memory allows the operator to stop the printer momentarily to check alignment and start the printer without significantly delaying the CPU.

My final consideration in my decision to purchase the printer concerned the technical and repair service.

Repair service may be obtained in two forms: purchasing a service contract or paying for each repair as needed on an hourly basis.

The service contract is best suited to a business desiring to have on-site service. Since my installation is small I chose to pay for repairs as they became necessary instead of incurring the overhead of a service contract (approximately \$25/month). In my case this option was more viable since the service branch is only 35 miles away.

Although I have not made use of the repair service, I have made use of their technical staff. The consultation was made via their toll-free number. The technical staff answered my questions in a prompt and professional manner. ■

“I saved in excess of \$250...”

"THE SPOKEN WORD"

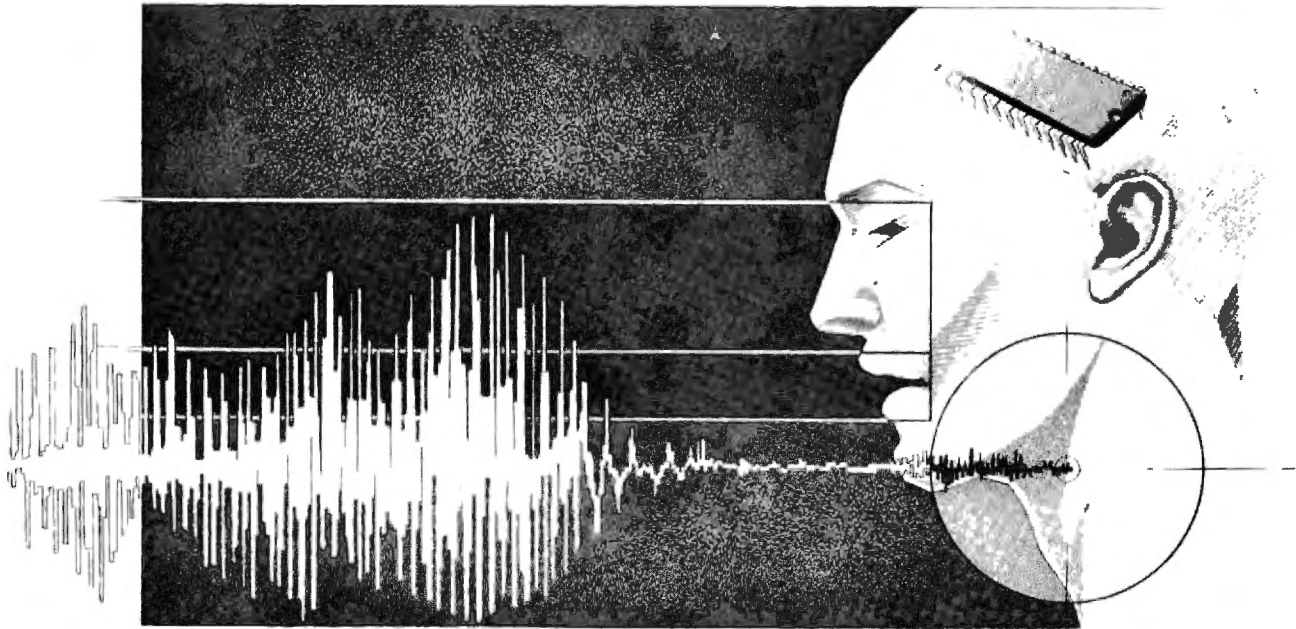

Man's Most Powerful Means of Communication Comes to Your Computer

Until recently, talking computers existed only in the fantasy of science fiction, or at a great cost in industrial and university laboratories. Since then, speech units have appeared commercially in the \$250 to \$350 price range, but with little sophistication and potentially low speech quality. *Voice Tech Industries* has a unique new manual for the *Apple* and *TRS 80** personal computers. Utilizing our methods and commercially available components, your personal computer can actually speak. This product is unique in several ways. Our technology is the newest in the industry, the speech quality is superb, and you can build it yourself for under \$50.00.

The *Voice Tech* 30 page manual is both educational and informative. It describes how complex speech waveforms are produced from the human vocal cavity and how these wave forms are electronically modeled. You will learn how advances in LSI semiconductor technology have enabled designers to put a digital model of the human vocal tract, a controller, and speech data on silicon. Complete, detailed instructions on interfacing speech hardware to the *Apple* and *TRS 80** computers are given. (The manual contains a coupon through which you can order the hardware components specified at a 50% discount). Also, professionally written software examples are provided that illustrate the fundamental principles and techniques.

Because speech is truly synthesized, the vocabulary is actually limitless. A common software interface can be shared among many different applications. Business reports can now be delivered verbally, educational programs can communicate via sight and sound, message centers can audibly report, and the potential for game applications is boundless.

Voice Tech has been in the speech synthesis field

since its inception. Because of our unique background, we have produced a clear, concise, and interesting document that we are now making available to the personal computer market. After reading the manual, the hardware can be added to your system as easily as any other standard peripheral. *Voice Tech* stresses that all products offered carry a full money-back guarantee.

To order, just fill out the coupon below and send it with your check or money order for \$9.95 to: *Voice Tech Industries*, P.O. Box 499, Fort Hamilton Station, Brooklyn, N.Y. 112090499.

And keep your ears open. What you'll be hearing is the voice of the future.

*Apple is a trade mark of Apple Computer Corp.
TRS 80 is a trade mark of Tandy Corp.

**How
to
Make
Your
Computer
Talk
for
Under
\$50.**

**VOICE TECH INDUSTRIES
P.O. BOX 499
FT. HAMILTON STATION
BROOKLYN, N.Y. 112090499**

390

My computer is

- Apple II or II plus
 TRS 80 Model I TRS 80 Model III
 Enclosed is \$_____ for _____
manuals at \$9.95 ea. which includes shipping and handling.
 Keep me informed of future developments in the speech industry.

Name _____
Address _____
City, State, Zip _____
Signature _____

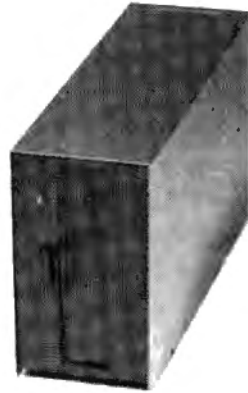
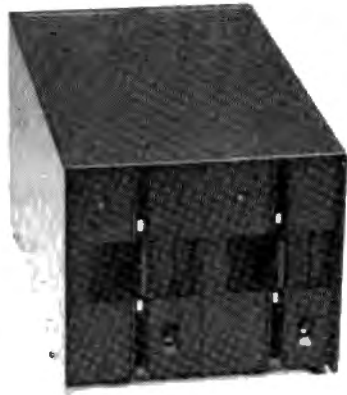

DISPLAYED VIDEO IS DRIVING DOWN PRICES ON DISKS

**"PRICE"
"CUT"**

**"PRICE"
"CUT"**

MODEL I OWNERS

80 TRACK TEAC DISK DRIVE W/CASE & POWER SUPPLY*

Single or Double Density

\$299.00

40 TRACK TEAC DISK DRIVE W/CASE & POWER SUPPLY

\$239.00

TWO CABLE DRIVE \$23.99

NEWDOS 80 \$125.00 When Purchasing a Drive

Bare Drives & Cases Available Upon Request

By the time you see this ad, DISPLAYED VIDEO's *Hard Disk* will be available to you.
Call for the Lowest Prices Available

**Only 132 Available. When they are gone, they're gone! (Act Soon)*

EPSON PRICES

We're not going to make you call for prices.
Here they are in black and white!!

MX 80 W/GRAPHTRAX \$459.00 Without GRAPHTRAX **\$439.00**

MX80FT \$545.00

MX100 \$729.00

PRINTER CABLE \$23.99

We Carry a Full Line of OKIDATA Printers

Visit Our Two
NEW RETAIL LOCATIONS:

886 Ecorse Road, Ypsilanti, MI 48197
(313) 426-5086/ (313) 482-4424

111 Marshall Street, Litchfield, MI 49242
(517) 542-3280



IMMEDIATE DELIVERY
90 Days Parts and Labor Warranty
DEALER INQUIRIES INVITED

*Free Shipping in the U.S.
48 Contiguous States*

Grand Opening of our Radio Shack Authorized Dealership at:
111 Marshall Street, Litchfield, Michigan 49242 P142

To Order: Call (313) 426-5086 or (313) 482-4424 or (517) 542-3280 or write DISPLAYED VIDEO,
886 Ecorse Road, Ypsilanti, Michigan 48197

*TRS-80 is a trademark of the Tandy Corporation

Prices subject to change without notice

✓62



DISPLAYED VIDEO IS DRIVING DOWN PRICES ON DISKS

DISPLAYED VIDEO is now offering TRS-80* MODEL III with TANDON or TEAC disk drives, your choice, one of the most reliable disk drive systems on the market, for incredibly low prices.

MODEL III with 48K, dual 40 track double density disk drives, complete systems with TRSDOS and one box of diskettes
PLUG IT IN AND GO \$1,799.00

MODEL III with 48K, dual 40/40 track double density disk drives, complete systems with Newdos 80 and one box of diskettes
PLUG IT IN AND GO \$2,199.00

MODEL III with 48K, dual 80 track double density disk drives, complete systems with Newdos 80 and one box of diskettes
PLUG IT IN AND GO \$2,199.00

MODEL III with 48K, dual 80/80 track double density disk drives, complete systems with Newdos 80 and one box of diskettes
PLUG IT IN AND GO \$2,499.00

MODEL 16 w/1 drive / w/2 drives **CALL**

4K Color Computer **\$314.99**

MODEL III Internal Drive Kit: Includes controller board, dual drive mounting bracket, dual power supply, all hardware cables and connectors **\$399.00**

Visit Our Two
 NEW RETAIL LOCATIONS:

886 Ecorse Road, Ypsilanti, MI 48197
 (313) 426-5086 / (313) 482-4424

111 Marshall Street, Litchfield, MI 49242
 (517) 542-3280



IMMEDIATE DELIVERY
90 Days Parts and Labor Warranty
DEALER INQUIRIES INVITED

Free Shipping in the U.S.
48 Contiguous States

Grand Opening of our Radio Shack Authorized Dealership at:
 111 Marshall Street, Litchfield, Michigan 49242 P142

To Order: Call (313) 426-5086 or (313) 482-4424 or (517) 542-3280 or write DISPLAYED VIDEO,
 886 Ecorse Road, Ypsilanti, Michigan 48197

*TRS-80 is a trademark of the Tandy Corporation

Prices subject to change without notice

✓G2

80 ACCOUNTANT

by Michael Tannenbaum C.P.A.

"Most were surprised when I advocated purchase of a hard disk storage unit."

During the past month, I have received several calls from would-be computer owners. Each caller wanted to install an integrated, computerized accounting system and requested guidance on a minimum equipment configuration. Most were surprised when I advocated purchase of a computer with a hard disk storage unit.

While it is feasible to install a fully integrated accounting system (Accounts Receivable, Payable, General Ledger and Payroll) on a Model I or similar personal computer, the accounting system is often difficult to use. The large number of files seriously restricts transaction and account data capacity. This usually requires splitting the data onto multiple disks, resulting in disk swapping to accommodate editing and data transfer requirements.

Until recently the Model II with its eight-inch disks was the best equipment choice if a firm desired an integrated system. However, even with the storage available for this computer, complex software such as the three-disk Tandy accounting system still requires disk swapping. Because floppy disks are fragile, disk swapping is not the most desirable alternative when implementing an accounting system.

Hard Disk Systems

The new hard disk systems offer a storage alternative to the computer owner seeking to install an integrated accounting system. Unfortunately, hard disks are still quite expensive, typically costing more than the central processing unit itself. Most units offered are of the sealed Winchester type with either a 5- or 10-megabyte capacity. Compare this to floppies, which can contain only a fraction of a megabyte on each disk.

The increased storage capacity of the Winchester disk is made possible by carefully controlling the disk environment and rotating the platter at an extremely high speed. The high speed of the disk forms an air cushion between the read/write head and the disk surface. Since the head never contacts the disk during data storage and retrieval its surface should last for an extremely long time. When you turn a Winchester disk off, the read/write head is moved to a safe landing area where it can contact the disk surface without en-

dangering data. The disk suffers a head crash when the head contacts the disk surface in a data storage area. Head crashes usually cause loss of all data stored on the disk.

In properly installed floppy disk systems, the prime provision for dealing with disk failure is to back up programs and data files at regular intervals. Then when the sad event occurs, only the work most recently performed is lost.

"Head crashes usually cause loss of all data stored on the disk."

In hard disk systems, similar back-up techniques are much more difficult to accomplish. Some hard disk systems contain a removable disk cartridge element. Unfortunately cartridges are quite expensive and somewhat fragile. Another method is to use a special removable data tape cartridge similar to a cassette. When you desire a back-up, you dump data onto the tape cartridge. Although tape cartridges are much cheaper than disk cartridges, they are considerably slower and therefore require more time when backing up data.

Tandy has not elected to provide any mechanical method of backing up hard disk data. The hard disk version of TRSDOS provides two new commands, Save and Restore, for file back-up purposes. These commands save selected files on the Model II's floppy disk when you have completed processing and restore them to the hard disk in case of need. When saving data, you can specify files either with a unique file name or with a wild card identification. Wild card specifications allow you to select a broad range of files with a single command. For example, the specification SAVE 4 to 0 (* /DAT) dumps all files with a /DAT extension on drive 0.

You need not format a data disk to save and restore files. TRSDOS automatically

formats and numbers floppy disks used in this process. If the files to be saved span more than one disk, another disk is called for and labeled (internally). If you use these disks for file restoration purposes TRSDOS checks the internal labels.

While a total back-up is not possible, the Save and Restore feature should be workable in practice. One method to protect essential data might be to include Save and Restore commands in software developed to work in the hard disk environment. At the end of processing, control would be transferred to a file which would direct saving essential files. Then, if a problem occurred, the data would be available for restoration. The commands necessary for this purpose would also be provided and activated when the problem was detected.

Unfortunately, software specifically designed for the Tandy hard disk has not yet been made available. You can adapt floppy disk systems for use on the hard disk but there are problems in implementation in addition to the lack of back-up procedures. Some problems, such as specific designations of disk drives, can be overcome by TRSDOS with the Floppy Off command; however, others are more troublesome. I found several examples of these problems when I was evaluating the Tandy three-disk Accounts Payable System #26-4605.

The Accounts Payable System

The three-disk Accounts Payable system is part of the Cobol integrated accounting system. Other elements include the General Ledger #26-4601 (evaluated in October 1981), Accounts Receivable #26-4604 (evaluated in July 1981) and Order Entry-Sales Analysis #26-4607 and #26-4608 (evaluated last month). In combination these three systems provide almost complete accounting automation for a trading-type enterprise.

Conversion of these systems from their floppy disk form to the hard disk is not difficult, and the resulting data processing package is enormous. There are more than 220 programs and 48 data files.

All sub-systems use a common company file. This file contains constant data such as the company name and address

DUNZHIN

by Randall Don Masteller

Dunzhin is Med Systems' first adventure/role playing game. Written by Randall Masteller, author of several non-computer D&D-type games, it is the first adventure/role playing game to combine fast, "from above" graphics, FAST response time, and COMPLETE computer implementation. There are no "rule books" to consult, and no waiting for the computer to "think".

Dunzhin places you in a huge dungeon of many levels. There are many treasures, but only one, deep in a hidden chamber, will win the game for you. Every game is different, but you can save a game in progress. You can also save the character you become as you gain experience in battling the goblins and demons waiting around every corner.



TRS-80 MODEL I 48K DISKETTE: \$29.95

TRS-80 MODEL III 48K DISKETTE: \$29.95

✓ 83

MED SYSTEMS SOFTWARE · P.O. BOX 3558 · CHAPEL HILL, NC 27514
TO ORDER, CALL: 1-800-334-5470

used to head reports, invoices and statements. Each sub-system also uses a common account file to specify accounts acceptable for data entry when processing. Unfortunately, the account file used for the general ledger is different from the account file used for receivables and payables. As a result you can create an account in a sub-system that is not a general ledger account. The system will detect this discrepancy when you update the general ledger, but in a system as sophisticated as this one, this type of problem should not occur.

If this system had been packaged for the hard disk unit, an account assignment problem would have never occurred. The account file used for all applications would have been the general ledger file and no mismatches would have been possible. Because the system was packaged for a floppy environment, it was probably impossible to have the general ledger account file resident while receivable and payable processing was in process. A special account file to verify account assignment was an accommodation to the limited storage available.

The use of an account file is not a problem for implementing accounts receivable and order processing. Even with a relatively large number of products the number of accounts affected by the receivable application is small. Accounts payable is another story. This application is the front end of the general ledger. You must place any account that could be affected by a cash payment in the valid account file. You may have to enter the majority of general ledger accounts in this file. With a complicated chart of accounts, this will be a time-consuming and potentially error-prone procedure. I am sure this task will be eliminated on the first true hard disk version of the Cobol accounting system.

If this system is implemented before the hard disk version is available, it is desirable to create the valid accounts file from a printout of the general ledger chart of accounts. As you might expect, correction of a mismatch detected during the general ledger update process is inconvenient and time consuming. You cannot correct the improperly coded transaction until you add an account with that coding to the chart of accounts. If posting then continues and the new account causes report preparation problems, the offending transaction will cause further inconvenience. You must then make an adjusting journal entry to transfer the amount to the proper account and delete the temporary account.

In last month's discussion of the order entry system, I covered the use of an on-

hand inventory in some detail. You had to enter inventory purchases into the order entry system with a file maintenance program. In a fully integrated accounting system, the accounts payable sub-system should supply inventory purchase data. This element of integration is unavailable in the Cobol system as currently supplied. In the future, or in a custom program, this level of integration could be added. Such a module would be called a "purchase order management system" and would use as input purchase advice data generated by the order entry system and receipts generated by the accounts payable system.

The Accounts Payable system uses installation procedures similar to the other sub-systems previously evaluated. As was the case in receivables, an alphanumeric vendor code is allowed. The balance of the data to be entered is not complicated. There is a provision for up to three address lines, type code, normal vendor terms, last purchase date and a purchase history. The operator can specify with a status code if the discount is always to be taken regardless of invoice dates or if the system is to hold all payments. If you select the option to hold payments, no checks payable to that vendor will be allowed. You will have to make payments manually. With an additional code, you could use the system to accumulate non-purchase data. While the purpose of this option is not explained, it appears you could use it for statistical purposes.

The system maintains purchase statistics on a comparative basis. This data could be very useful in defining vendor relationships. At the end of the year, a closeout procedure clears out the current year's data and transfers the totals accumulated to the prior year. Since both purchases and discounts taken are maintained, reports of these totals should be very valuable.

In operation, you enter data into this system by use of vouchers. The system allows entry of four types of vouchers: regular vouchers, cancellation vouchers, non-A/P check vouchers and adjustments to previously recorded distribution vouchers. When you select the add voucher option, a screen which allows entry of part of the voucher detail is displayed. This data corresponds to the upper portion of a handwritten voucher and indicates the system-assigned voucher number, transaction type (detailed above) vendor code and name, distribution date, purchase order number and vendor's invoice totals. Once this information is recorded, distribution of the invoice amount is required. There appears to be no limit to the number of distributions available; however, only the last two (the

current entry and a running total of the balance yet undistributed) are displayed.

In some organizations complex invoice distributions are required. Retailers, for example, may make bulk purchases of supplies and ship the material to many stores. It is not unusual in such a firm to require 20, 30 or more distributions of an invoice amount. This payable system would be useful in such an environment; if the system capacity (1500 vendors, 800 open items, and 5000 general ledger distributions) is adequate, it should be considered suitable for installation.

You enter vouchers into a buffer. There you can alter them with comparative ease. However, once they are posted to the Accounts Payable file, editing becomes more complicated. Since an error such as an improper account coding could be difficult to correct after posting, the system provides a method of adjusting the distribution of posted vouchers. This is typical of the options available for transaction handling and help to make this system quite user-friendly.

After you enter transactions, edit reports are available. They are similar to the other systems in content and format. A description of any codes which you might use in the detail line of the report are clearly spelled out in the body of the report.

This is a thoughtful touch which casual users of the system's reports will appreciate. If you make an incorrect or unacceptable response to a prompt, the system prints a short banner message indicating options available and their meaning. If you attempt to leave a screen without completing some essential piece of information, the system inhibits exit until you enter the missing data. Once you have mastered all the system conventions, it is quite easy to use.

One of the main reasons for installing an automated accounts payable system is to take advantage of vendor credit. With the high interest rates, this form of credit may be the best way for a firm to grow. This system contains reports which allow optimum use of this means of financing. You can generate cash requirements and lost discount reports which would be quite difficult to prepare with a manual system. Proper use of these reports could generate enough income to pay for the complete computer system over and over again.

Most firms, however, automate accounts payable because check preparation has become burdensome. Check preparation is rarely spread equally over a month. Preparation of checks is usually jammed into just a few days. This makes the task tedious and noticeable in most

BORN TO RUN

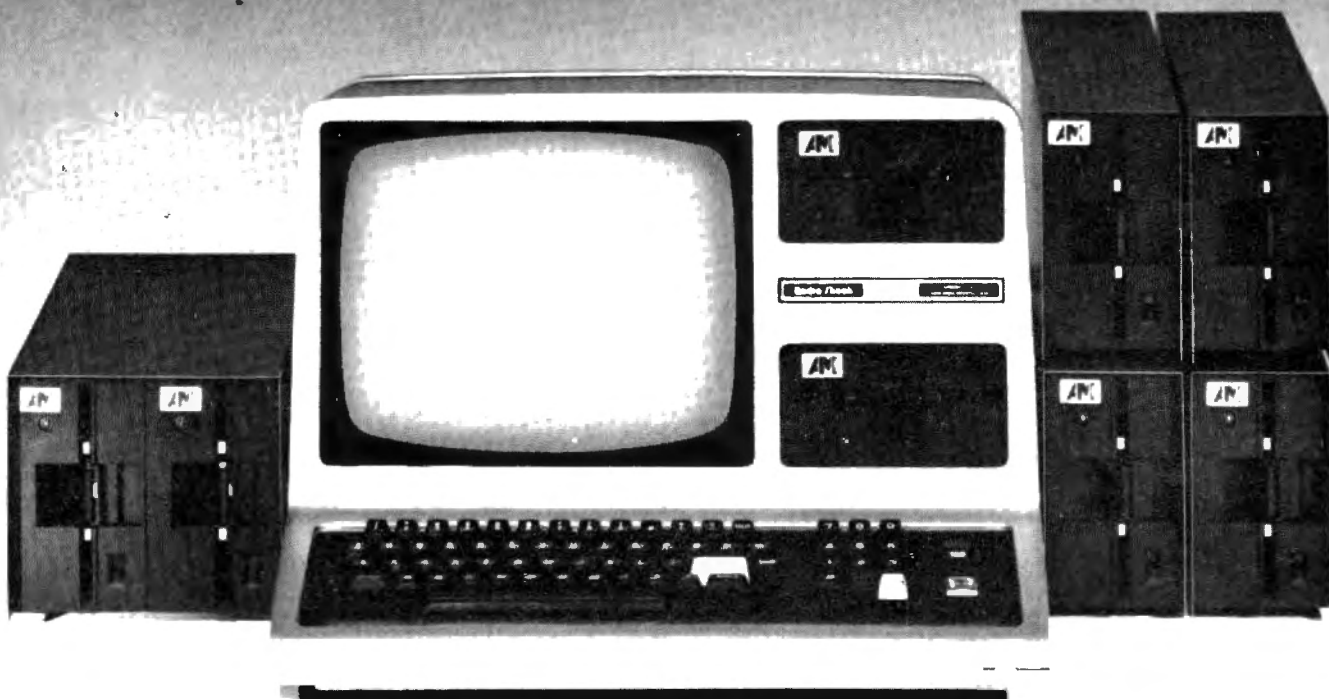

**Get your TRS-80™ up and running
with special system & disk drive values like these . . .**

**Complete TRS-80 Model III
microcomputer system with disk drives**

A.M. Electronics Model III with 48K RAM, two Tandon 40-track double-density disk drives, A.M. Electronics controller board, DOS and manuals, complete and ready-to-run! \$1895.00

Prepaid shipping when order is pre-paid.

A.M. Electronics "Multiplier"

Tired of unreliable double density operation? With Multiplier, you can upgrade from a single-density without doubling your problems \$99.95

Your Choice:

- Teac or Tandon 5¼-inch disk drives, complete!**
- 40-track single side disk drive with power supply, case and extender cables \$250.00
- 80-track single side disk drive with power supply, case and extender cables \$340.00

Memory Chips

16K 200 nanosecond RAM chips \$2.00 each

**New! Teac double-head
5¼-inch 40-track disk drive!**

Complete with power supply, case and extender cables \$340.00

**New! Tandon "Thinline"
8-inch disk drive, complete!**

For TRS-80 Model II, complete with dual case, power supply, and cables \$695.00

**New! Hard disk drives for Model III —
Ready to plug in and run!**

- 6.5 Megabyte drive \$1995.00
 - 9 Megabyte drive \$2195.00
 - 14 Megabyte drive \$2395.00
- (DOS extra)

TRS-80 Model III Commented

The definitive guidebook to Model III ROM . \$15.00

Shipping costs additional except where otherwise noted.



A.M. ELECTRONICS

✓3B

Ann Arbor: 3446 Washtenaw Ave., Ann Arbor, MI 48104 (313) 973-2312

Open M-F 10-6, Sat. 10-5. Telex: 220-821-HPC

Fowlerville*: 111 North Grand, Box 1071, Fowlerville, MI 48836 (517) 223-7281

Attention Dealers, OEM's & Distributors: Call us for details on our attractive pricing.

*Authorized Radio Shack Dealer. ™TRS-80 trademark Tandy Corp. Prices subject to change without notice.



Proof Notes

the editors look at the issues

Continued from page 10

artist. A musician can write music using anything from a pen, to a tape recorder, to a computer. And there's the rub; as soon as you mention a computer, people get fidgety and start wondering how much the computer had to do with it. Does storywriting lose any of its artistic value because it was written using a word processor? Does a delicate pattern lose any of its visual appeal because it was created on a video screen?

"I think most people would agree that the answer to both these questions is no. But how about when a whole story is apparently written by a computer? Well of course it wasn't written by a computer: It was written by a program which ran on a computer. The author took one extra step and created a program as an invisible part of the creative writing process. The more work that is put into the program, the less work that may be needed. This is where computers bring a whole new dimension to the artistic world and in my opinion may change the fabric of many art forms.

"The computer-generated novel is in reality written using certain aesthetic parameters that were placed in the program (whether consciously or not) by the human author. That author still has to decide whether or not the end result has anything approaching quality. All he has done is left the process of composition until after the composition was performed.

"Another exciting thing that computers do is allow much faster experimentation with a central idea. This idea has already been used in the field of computer music. Imagine the effort involved in taking a Beatles song and rewriting it in a baroque style, or calypso, or jazz. With each effort the composer (or recomposer) may be risking hours of work possibly to be rewarded with disappointment.

"A computer can easily manipulate the data (in this case the musical score) and allow many separate attempts at recreation. Using systems like the New England Digital musical synthesis system (the Synclavier), it becomes possible to change the instruments while a piece is actually being played. With this system, instead of the interface to the computer being through a typewriter-style keyboard, the input is mostly through a piano-style keyboard. This has the psychological effect of removing the computer from the creativity loop, placing into the background the uncertainty of "who's doing what—human or computer?"

"This versatility is not without its price. The possibilities opened up by having a computer handle the donkey work can be almost endless. Unfortunately, many artistic people have a difficult enough time knowing when to stop without having thrust upon them the temptation of improving the result by yet another try.

"Another useful function that can be performed by a computer is in providing random elements to the creative thought processes of the artist. Many times artists fall victim to their own previous output and fail to come up with new ideas simply because they are in a rut. Computers are great at doing things in too literal a manner, thereby producing results totally unpredicted by the artist-programmer. This phenomenon can be exploited in all sorts of ways to initiate a synthetic brainstorming session between human and computer.

"So now we finish up almost on speaking terms with the computer. Nothing to be afraid of was there? The computer plays its part in the creative process but takes no more from the artist than the artist puts in, exactly the same as with our numerical artist friends—the mathematicians; where would they be without the computer? Few people think of mathematicians as artists, so nobody ever questions the role of the computer and whether or not it compromises the aesthetic qualities of the mathematical concepts or results that have evolved in the last 20 years. The mathematical art is probably more refined as a result of computers than it ever was.

"As micros become more of a way of life for everyone, I feel we are about to embark on an exciting new creative period. No doubt there will be a vogue for a while of art for computing's sake, but when that passes we will have a generation of artists that can place the computer in the creative process to any extreme they desire and produce "art." That period can be now if you want it."

There will always be those who prefer the classics to the avant-garde. After all, how can a Botticelli be compared with a screen-printed painting by Andy Warhol; and yet they are both immensely popular. Although you may not prefer computer-composed art, it is still necessary to acknowledge it, if only for the reason that it exists. It is a creative endeavor between man and machine that is certain to evolve in the future.

Janet Fiderio
Feature Editor

any size firm. Check preparation with this system is relatively easy. You can select vouchers to be paid by several criteria. Once you have determined the criteria, the system will go through the files and select those vouchers which meet your requirements. You can review the vouchers selected and make decisions to pay on a voucher-by-voucher basis. The system allows partial payment of a voucher.

After the selection process has been completed, you can prepare a pre-check writing report. If this report indicates that all is well, you can write checks. The system uses preprinted check forms described in the documentation. You can obtain the forms from a vendor recommended by Tandy or the firm's normal forms supplier. If you select Tandy's vendor, they provide either a one part or three part form. Since the system does not retain any historical data, you should keep a printout of the actual check and remittance advice. Then should research into a vendor's payment history be required, data will be available. For this reason, I suggest use of the multi-part form.

The remittance advice portion of the check form has room for up to 16 vouchers. If this number is exceeded, the system voids the check portion of the form and continues printing the voucher detail on the next form. Only one check is allowed for each vendor. If the amount selected for payment, net of credits is negative, a check will not be printed. The system allows printing zero balance checks. This allows the user to send advice to the vendor detailing how credits were applied to open invoices.

Because printers could fail or in some way destroy the checks printed, an option is available to restart the printing process. If you must void all the checks as a result of printer failure, you can accomplish this with a single command. After a successful batch of checks has been prepared, the system creates a check register.

The Accounts Payable system, like the other systems evaluated, is a good system. It contains those procedures and reports that should be in a computerized accounting system. While successful in a floppy disk environment, it will operate very slowly. If speed is not important and the client has a well organized and patient computer operator, you need not hesitate to install it. Unfortunately, these conditions rarely apply in practice. As a result I do not believe that the floppy system will be the future of small business computing. With the hard disk, the combination of the Model 11 (or 16) and the Cobol accounting system could very well be the accounting machine replacement system of the future. ■

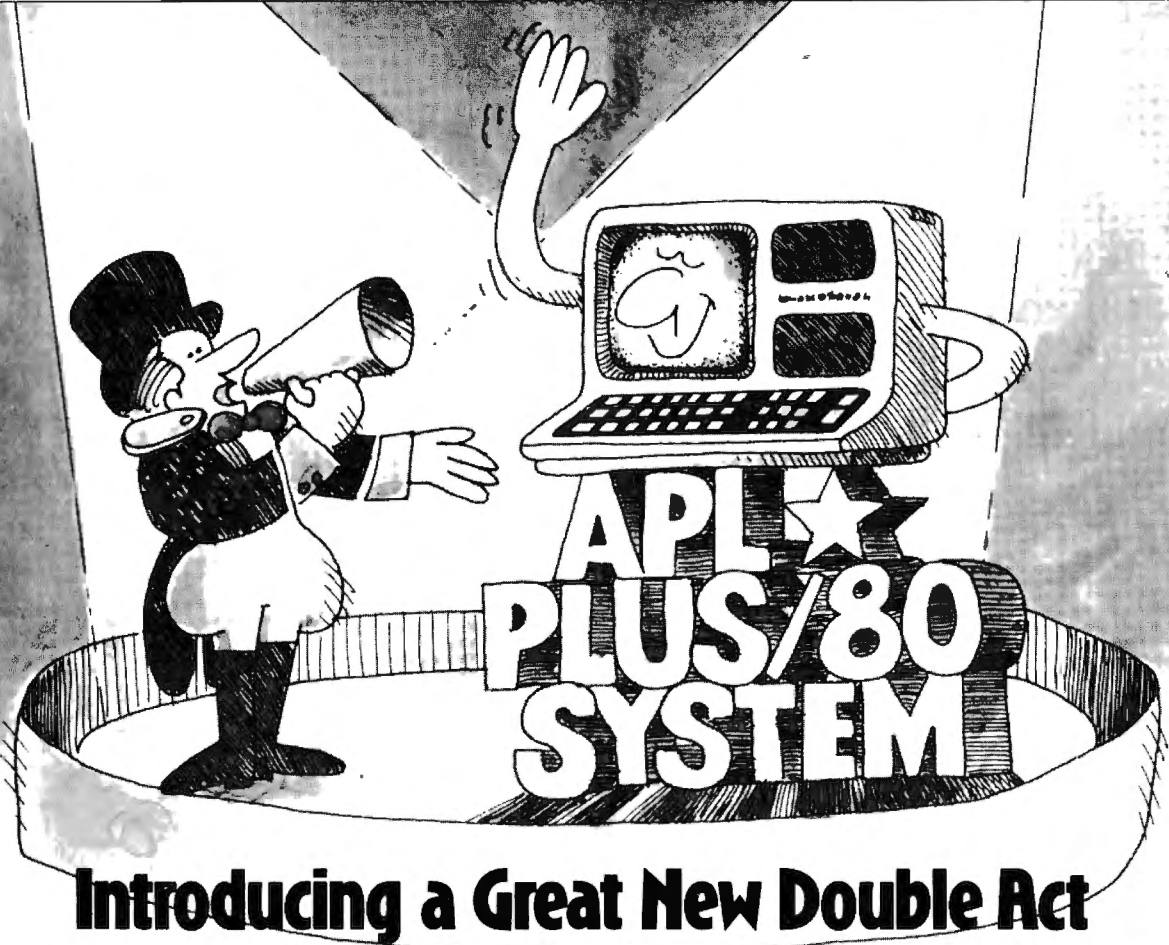

Introducing a Great New Double Act

Faster, easier, more powerful programming! STSC's APL★PLUS[®]/80 System brings the productivity of APL to your TRS-80[™] Model III. Here's your escape from the restrictions and wordiness of BASIC.

With our **APL★PLUS/80 System**, you can develop and maintain programs in one-fourth to one-tenth the time needed with BASIC, because one symbol in APL often does as much as an entire statement in other languages. So you can write applications in APL that you'd hesitate to attempt in BASIC.

A Complete Application Development System

It's our language support features that put the PLUS in **APL★PLUS/80**. You get:

- complete APL, upwards compatible to our mainframe APL systems
- powerful output formatter
- array-oriented file system
- access to regular TRSDOS files and subroutines
- communications as both a "smart" and a "simple" terminal
- traditional APL symbols or mnemonic keywords
- utility program libraries
- convenient access to many TRS-80 features
- complete documentation, including *APL is Easy!* (introductory tutorial), APL textbook, and a set of four detailed user's guides and reference manuals—everything to support the beginning user to the experienced APL programmer.

APL★PLUS/80 runs under TRSDOS 1.3 or LDOS on a 48K RAM TRS-80 Model III with two disk drives. The **APL★PLUS/80** comes with custom APL character ROM.

Join the software consultants who have already selected **APL★PLUS/80** to develop and deliver solutions. Mail in the coupon below with your payment and we'll rush you the **APL★PLUS/80 System**—all you need to run APL on your TRS-80 Model III today.

We've prepared a free information package to answer your questions about APL, **APL★PLUS/80**, and their advantages to you as a TRS-80 user. Just send in the coupon.

We're STSC, Inc., the largest supplier of professional quality APL software and services in the United States. Our **APL★PLUS** systems have been serving the business and professional world for more than 12 years.

Challenge to Basic

Draw a bar graph on a cleared screen with up to 13 vertical bars 5 pixels wide (separated by 5 pixels) using heights given by keyboard input.

Using APL:

```

▽ BARGRAPH;I;N
[1] 'ENTER UP TO 13 HEIGHTS (FROM 0 TO 48 EACH):'
[2] I←DN*,⊂⊆ ⊆TCPP A INPUT, CLEAR. PLOT, LOOP:
[3] LP:(1N[I])∘.⊆SPOT(10×I-1)+15 ⊆→(0<I-1)ρLP
▽

```

This APL program with this numeric input

```
32 6 41 25 48 2 19 0 36 48 45 12 9
```

draws the entire graph in under five seconds. How fast does your BASIC program draw the graph, and how complicated is the program?

A detailed explanation of this APL solution and a comparable BASIC solution are included in the information package.

stsc

266

Attn: **APL★PLUS/80** Distribution

STSC, Inc., 2115 East Jefferson Street
Rockville, Maryland 20852

(301) 984-5000 (orders only)

Yes, send me the APL★PLUS/80 System.

My check for \$295 is enclosed.

Charge my VISA Account # _____

Charge my MasterCard Account # _____

Expiration date: _____

I'd like to know more about **APL★PLUS/80**. Send me your free information package.

Name _____

Title _____

Company _____

Address _____

City _____ State _____ Zip _____

Phone(_____) _____

SOFT BITS

a basic/assembly column

by Roger Fuller

I began my first column (December 1981) with the sentence "This column is dedicated to those who have read the books and still cannot write assembly or machine code programs." I repeat it here because some readers may have drawn a false conclusion. I am not trying to teach Assembly or machine language in lieu of those books but in addition to them.

Lance Micklus has suggested using the concept of parallel reading when you want to learn something new. I choose topics which I feel are not well represented in the writings available on Assembly and machine coding. Therefore I will not waste valuable space on the usual discussion of op-codes.

How should you study Assembly and machine language programming? Lance's suggestion of reading more than one source is excellent. Since we each have our own peculiar ways of learning, one author's treatment of a topic may be just right where another's may leave you even more confused.

A good study is a close study. You cannot expect to learn as quickly as you read words. When I was young I became interested in electronics. To learn about it I checked out all the books on the subject the small town library had. After reading them once, I reread them word by word, sentence by sentence, and diagram by diagram until I felt I understood what was written.

To learn Assembly language that way, simply take your resource library and use it to decipher the sample programs in *80 Micro*. This slow process pays off in a thorough understanding. The example programs I have given all work in or with Basic. This allows you to use, modify and play with the code. Modifying code is the next step toward writing your own programs.

Old Business

Because I write this column in Texas and send it to New Hampshire, sometimes things get lost. My first column was missing a two-line Basic program that loads the code for the keyboard filter into an unused spot in memory. This short piece of Basic code makes using the filter

program easy (see the Program Listing). In January's column there was a mistake in Fig. 2. The arrow was pointing the wrong way and the caption for the arrow had the DE and HL registers reversed.

"I am not trying to teach Assembly or machine language in lieu of these books but in addition to them."

February's column was missing an explanation of that month's program. This program will not require you to set memory size if you do not list Basic lines longer than 150 characters (about 2½ video lines). This is because the machine code is placed in the input buffer. You can relocate the code by changing the POKE statement in line 65528. It will work on Models I and III with or without an operating system.

This program patches the Input statement so that it will not allow input past 150 characters and will 'lock-out' the clear and down arrow keys to preserve your screen format. Many INKEY\$ input routines are available but all suffer from excessive string space use and slow response time. To use it, simply execute once; subsequent uses of the input statement will be patched. You can add more code to check for numeric input, display an underline for the input length, strip leading or trailing spaces, or whatever.

I would like to congratulate Robert Kirk of Kansas for being first to spot the erroneous LD DE,HL instruction in Fig. 1 in the February column. My explanation in the paragraph above that figure made it clear that such an instruction cannot be true. Robert has given me some constructive criticisms on my column. Please send your comments or suggestions to me, Roger Fuller, 630 E. Springdale, Grand Prairie, TX 75051.

New Business

This month I would like to discuss good old Basic. Remember that Basic is a Z80 program. I emphasize the importance of thinking in terms of memory when you are programming. The following discussion of some of Basic's quirks should re-establish it in the ranks of Assembly language programs.

Try typing this line into the computer.

```
0 PRINT "80";:GOTO
```

It runs! But why? Basic evaluates the line number directly after the GOTO. The evaluation ends at the first character that is not a space, a numerical digit, or a line feed. Because there is no line number (or a line number of zero), the loop executes.

Now type the following program and run it.

```
0 PRINT 1 2 3 4 5 6
1 PRINT 1
  2
  3
  4
  5
  6
2 PRINT 1234567
3 PRINT 123435678
```

Lines 1 and 2 return the number 123456. The Basic code which scans the program text is RST 10H. Since it evaluates a numeric expression, it ignores spaces and line feeds. The number 1234567 in line 2 was evaluated as a single precision number, but in single precision only six digits can be printed; hence, the conversion to exponential notation. The number in line 3 exceeds single precision, so it was converted to be evaluated as double precision.

Spaces are critical in converting Basic reserved words to tokens for either storage or execution. TAB (10) is an array variable while TAB(10) is a Tab statement. But try to type the reserved word GOTO with spaces between the letters. Do the spaces stay there if the word is stored in a program line? Try typing and entering three spaces and an apostrophe in the command mode.

The input statement is interesting to

\$2495 PUTS YOU IN BUSINESS

Introducing the M.T.I. BUSINESS Computer. We believe in offering you the best in complete, low cost computing.

M.T.I. MOD III-B/140. We have taken the basic MODEL III, expanded the memory to 48K and added our M.T.I. double density, dual drive system. All M.T.I. BUSINESS computers include 4 Mhz speed-up for remarkable fast processing, a RS-232 Interface, Anti-Glare screen and cooling unit.

LOW PRICE. M.T.I. BUSINESS computers are priced from \$2495. As an added incentive, we will give you an integrated business software package **FREE** with the purchase of a MOD III PLUS BUSINESS computer. The software package has a retail value of \$1588.00. **All of this for \$2495.**

FREE SOFTWARE

ACCOUNTING PACKAGE

- ACCOUNTS RECEIVABLE
- ACCOUNTS PAYABLE
- GENERAL LEDGER
- INCLUDES AUDIO SELF-LEARNING CASSETTE
- INVENTORY/SALES ANALYSIS
- PAYROLL
- GAMES/EDUCATION SOFTWARE
- DOS PLUS 3.3

WORD PROCESSING

We are also offering a discount certificate entitling the purchaser to **NEW SCRIPT** by Pro Soft. With **NEW SCRIPT** you have complete word processing software.

OTHER MODELS AVAILABLE.

MOD III/240-B. Same as the MOD III-B but has double storage capacity and dual headed 40 track drives.

MOD III/280-B. Has 1.5 Megabytes storage and 2 dual headed 80 track double density disk drives.

MOD III/WINCHESTER-B. Our largest business computer system 8.2 megabytes of storage. Includes a 7.5 megabyte WINCHESTER hard disk and 80-track dual head disk head.

OPTIONS:

- * LETTER QUALITY PRINTER
- * WINCHESTER CP/M 2.2

WANT MORE? For more information call any of our authorized sales centers.



- 90 Day Warranty
- One Year Extended Warranty Available
- Local Dealer Service
- TRS -80 Compatible

MTI AUTHORIZED SALES AND SERVICE CENTERS

Anchorage, AK ... (907) 333-8322
 Rodgers, AR ... (501) 635-9168
 Mesa, AZ ... (602) 833-8949
 Phoenix, AZ ... (602) 241-1865
 Sierra Vista, AZ ... (602)458-2479
 Tempe, AZ ... (602) 831-5376
 Tucson, AZ ... (602)323-9391
 Anaheim, CA ... (714) 773-0240
 Burbank, CA ... (213) 841-4210
 Covina, CA ... (213) 332-4088
 Goleta, CA ... (805) 967-7628
 Inglewood, CA ... (213) 673-3295
 Lancaster, CA ... (805) 942-5747
 Montclair, CA ... (714) 626-4813
 Northridge, CA ... (213) 886-9200
 Orange, CA ... (714) 771-0880
 Pacheco, CA ... (415) 689-2260

Placerville, CA ... (916) 622-4640
 Port Hueneme, CA ... (805) 985-2329
 Redondo Beach, CA ... (213) 370-5556
 Riverside, CA ... (714) 781-6361
 San Diego, CA ... (714) 275-4243
 San Jose, CA ... (408) 946-1265
 Santa Monica, CA ... (213) 935-5785
 Vallejo, CA ... (707) 554-4933
 Walnut, CA ... (714) 594-9760
 Westlake Vil., CA ... (213) 706-0333
 Colorado Springs, CO ... (303) 630-3334
 Grand Junction, CO ... (303) 434-3616
 Groton, CT ... (203) 445-5166
 Wilmington, DE ... (302) 762-0227
 Hollywood, FL ... (305) 981-1011
 Mary Esther, FL ... (904) 243-5793
 Panama City, FL ... (904) 769-5887

Tampa, FL ... (813) 247-6023
 Norcross, GA ... (404) 449-8982
 Honolulu, HI ... (808) 521-7312
 Buckingham, IA ... (319) 478-2826
 Belleville, IL ... (618) 277-2354
 Collinsville, IL ... (618) 345-5068
 Oak Park, IL ... (312) 386-3323
 Shreveport, LA ... (318) 865-7189
 Hopkinton, MA ... (617) 435-4772
 Springfield, MA ... (413) 373-7462
 Anoka, MN ... (612) 427-5783
 Cameron, MO ... (816) 632-6528
 Joplin, MO ... (417) 782-0880
 Great Falls, MT ... (406) 727-0901
 Missoula, MT ... (406) 549-9715
 Raleigh, NC ... (919) 755-1175
 Grand Forks, ND ... (701) 772-7848

West Milford, NJ ... (201) 728-8080
 Las Vegas, NV ... (702) 870-4138
 Jericho, NY ... (516) 333-2266
 New Rochelle, NY ... (914) 235-4444
 Syracuse, NY ... (315) 474-1442
 Troy, NY ... (518)273-8411
 White Plains, NY ... (914) 761-9283
 Cleveland, OH ... (216) 867-3700
 Toledo, OH ... (419) 535-5897
 Tonkawa, OK ... (405) 628-2693
 Tulsa, OK ... (918) 836-9503
 Klamath Falls, OR ... (503) 884-4315
 Portland, OR ... (503) 281-7640
 Dallas, TX ... (214) 698-9995
 Missouri City, TX ... (713) 499-5241
 San Angelo, TX ... (915) 658-3781
 Cheyenne, WY ... (307) 632-9132



MICROCOMPUTER TECHNOLOGY INC.
 3304 W. MACARTHUR, SANTA ANA, CA 92704
 (714) 979-9923 • TWX 910-595-1902 MTISNA

Call or write for free brochure:
 U.S. PRICES F.O.B. SANTA ANA
 CALIFORNIA AND MAY VARY BY AREA.

CP/M is a registered trademark of Digital Research, Inc. ✓247
 Radio Shack is a registered trademark of Tandy, Corp.
 M.T.I. is a registered trademark of Microcomputer Technology, Inc.

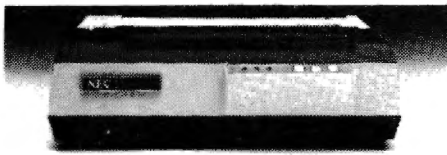

NEC PC-8023A-C Printer

\$499⁹⁸ DELIVERED

- 100 cps bi-directional printing
- Adjustable tractor/friction feed
- Proportional spacing
- Hi-res dot-addressable graphics
- True descenders in 5 fonts
- Subscript, Superscript & underlining

Okidata Printers

MICROLINE 80	\$369 ⁹⁸
MICROLINE 82A	\$479 ⁹⁸
MICROLINE 83A	\$739 ⁹⁸
MICROLINE 84 (Parallel)	\$1059 ⁹⁸
MICROLINE 84 (Serial)	\$1194 ⁹⁸
OKIGRAPH ROM—adds Hi-Res capabilities to 82A and 83A Printers	\$89 ⁹⁸

IDS Printers

PRISM 132 (Color)	\$1699 ⁹⁸
PRISM 80	\$989 ⁹⁸

Epson Printers

MX-80 w/GRAFRAX	\$474 ⁹⁸
MX-80/F-T	\$569 ⁹⁸
MX-80/F-T w/GRAFRAX	\$619 ⁹⁸
MX-100	\$719 ⁹⁸
GRAFRAX	\$89 ⁹⁸

Centronics Printers

CENTRONICS 739 (Parallel)	\$539 ⁹⁸
CENTRONICS 739 (RS-232-C)	\$644 ⁹⁸
2-Color Adapter	\$69 ⁹⁸

C.Itoh Printers

C.ITOH COMET I	\$284 ⁹⁸
C.ITOH PRO WRITER w/3K buffer (parallel and serial)	\$639 ⁹⁸
C.ITOH F-10 DAISY WHEEL (40cps)	\$1539 ⁹⁸

Cables and interfaces available for the APPLE, ATARI, CBM/PET, IBM, OSBORNE, and TRS-80.

Orders & Information:
CALL (603)-673-8857

Orders Only: CALL (800)-343-0726

We accept CODs—No surcharge for credit cards. No charge for UPS shipping—Stock shipments next day—All equipment shipped factory fresh with the manufacturer's warranty.

Prices subject to change

HIGH TECHNOLOGY AT AFFORDABLE PRICES

THE BOTTOM LINE

✓302

12 Johnson Street, Milford NH 03055-0423

70 • 80 Microcomputing, May 1982

SOFT BITS

study. Try these lines.

```
0 INPUT
1 INPUT
2 INPUT LS
3 PRINT LS
```

Now run it. Press Enter for the first statement and enter a zero for the second. You have always been told that you cannot enter a quotation mark except as a delimiter during an Input statement. On the third statement enter a letter followed by a quotation mark or marks. Basic allows the quotation mark because it determines if the first character is a quote. If it is not, Basic accepts all characters until it finds a delimiter. This delimiter must be a comma, a colon, or end-of-line marker.

MEM and FRE are very close cousins. (MEM is free memory, and FRE is unused string space.) Try the following code.

```
00 IF MEM = MEM PRINT "TRUE"
1 PRINT MEM
2 PRINT FRE(1982)
3 PRINT FRE(" ")
```

Line 0 falls through because stack space holds the value of the first MEM. Lines 1 and 2 produce the same result because Basic uses FRE(0) to produce the result of MEM. Finally, line 3 has a quote as an argument; this makes Basic compute string space instead of memory only.

Radio Shack has warned about using the VAL function on negative numbers. Let me point out some other danger areas.

```
0 PRINT VAL("10%")
1 PRINT VAL("10 E 38 ST.")
2 INPUT N
3 PRINT N
```

Note the errors caused by the percent sign and by special notation. E indicates exponentiation in single precision; D indicates it in double precision. Enter either E or D for line 2. They are considered as numbers, not strings!

The next program is a favorite of mine.

```
0 GOSUB 3 TEXAS OR BUST
1 GOSUB 3 REM EMBER THE ALAMO
2 GOSUB 3 REM ; BUSTED
3 RETURN
```

Strangely, Basic accepts line 0 but produces a syntax error on line 2.

A few more:

```
0 PRINT = 0: PRINT PRINT = - 1
1 FOR X# = 1 TO 10: NEXT
2 FOR X(1) = 1 TO 10: NEXT
3 IF "A">"A" PRINT "TRUE" ELSE PRINT "FALSE"
```

The first line is an assignment statement followed by a printing of the value (- 1 if true or 0 if false) of an expression. The next two lines are not allowed in Basic, since only integer and single precision simple variables are allowed in a For...Next loop. The last line will work right if the first Print statement is not immediately after the inequality.

Normally only 240 characters including the line number can be entered for a line of Basic code. This increases to 255, not counting the line number, when you edit the line. The shortest line allowed by Basic contains only an end-of-line marker, the zero byte. The longest line is limited only by your memory. I have occasionally for security reasons used lines longer than can be listed. This keeps sensitive code out of the hands of ordinary people.

"this keeps sensitive code out of the hands of ordinary people."

The largest line number you can enter by normal means is 65529. It is possible to have a line number 65530 and still be able to list it. Type and run the following one-liner:

```
250 POKE PEEK(18548) + PEEK(18549) + 256 + 3, 255
```

Now try to edit the line. Basic cannot convert the line number 65530 since it is above the 65529 limit. You can edit the line by listing it and then using the edit period ability of Basic. You might try increasing the line number size from 250 to 251, then 252, and so on until you construct a 65535 line number. Even stranger things happen there! ■

```
65528 FOR M=1 TO 32*4 STEP 4 : POKE 16477 + M/4, VAL(MID$( " 042 0
22 064 237 075 109 064 237 067 022 064 034 109 064 201 205 108 0
64 254 032 208 254 013 200 254 008 200 254 001 200 175 201", M, 4)
): NEXT
65529 IF PEEK(16396) = 195 THEN DEFUSR1 = &H405D: M = USR1(0) : R
ETURN ELSE POKE 16526, 93 : POKE 16527, 64 : M = USR(0) : RETURN
```

Program Listing

Subscribe
to CCN

Color Computer News



Are you tired of searching the latest magazine for articles about your new Color Computer? When was the last time you saw a great sounding program listing only to discover that it's for the Model I and it's too complex to translate? Do you feel that you are all alone in a sea of Z-80's? On finding an ad for a Color Computer program did you mail your hard earned cash only to receive a turkey because the magazine the ad appeared in doesn't review Color Computer Software? If you have any of these symptoms you're suffering from Color Computer Blues!

But take heart there is a cure!

It's COLOR COMPUTER NEWS.

The monthly magazine for Color Computer owners and only Color Computer owners. CCN contains the full range of essential elements for relief of CC Blues. Ingredients include: comments to the ROMS, games, program listings, product reviews, and general interest articles on such goodies as games, personal finances, a Kid's page and other subjects.

The price for 12 monthly treatments is only \$21.00 and is available from:



Mail
Today!

REMarkable Software
P.O. Box 1192
Muskegon, MI 49443 ✓ 145

NAME _____
ADDRESS _____
CITY _____ State _____ Zip _____

Allow 8-10 weeks for 1st issue. 80 M



AUTO-WRITER

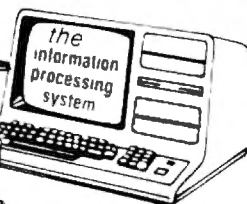

NEW!

YOU ALREADY OWN THE BEST DATA BASE MANAGER AVAILABLE . . .



It's Your Word Processor . . .

Use your word processor to create and maintain a **FREE-FORMAT** data base. There is **NO NEED TO ABBREVIATE** because of fixed-length fields.

Sort your data base by any field.

Print form letters and reports, automatically selecting and extracting information from your data base.

Use format codes to control the printing of form letters and reports.

Create subsets of your data base with the powerful **SELECT-IF** software.

Requires 48K, 2 disk drives, and lower case Model I or III. Available for most Disk Operating Systems.

NOW AT THE SPECIAL INTRODUCTORY PRICE OF \$72.83

(Manual available separately for \$20.00)

AUTO-WRITER . . . IN A CLASS BY ITSELF

WRITE OR CALL NOW FOR A FREE BROCHURE

MIDWEST DATA SYSTEMS

a division of Walonick Associates, Inc.

5624 Girard Ave. So., Minneapolis, MN 55419

(612) 866-8022

✓ 148

MONEY MAGIC!



doughflo

DOUGHFLO. The Most Useful Program a Home or Business Manager Can Have! ✓ 112

Designed For The Decision Maker, Doughflo is an interacting system of programs for cash flow analysis, budget planning, and bookkeeping

In The Home, Doughflo becomes a key tool in solving the puzzle of balancing expenses vs. income. Doughflo shows you where the money goes.

Fire Your Bookkeeper! You, the new bookkeeper, will have easy access to all expense records. Rapidly find and display any number of entries by description, type, amount, date, or number.

Simple To Use, Doughflo is quick and efficient, carefully guiding you from data entry to report generation.

900 Entries In Memory at one time with 48K machines. No time consuming disk access.

Sort 900 Entries In Only 2 Seconds! Sort by check number, description, date, or month.

User Friendly! Detailed instructions. Input screens and single keystroke commands allow quick and easy data entry and computer interaction

Amazingly Versatile! Indispensable in home or business for:

- Budget Planning
- Bookkeeping
- Tax Preparation
- Financial Analysis

Reports! Compare expenses and income vs. budget, total expenses, percent of total expenses, etc. Up to 24 months can be compared at once.

Gain Valuable Insight. Doughflo is ready to save you time and money. Requires 32K and one or more disk drives, specify Model I or III. \$98.95 postpaid to continental North America. For more information check reader service number.

**"A
PERFECT
CLOAD
EVERY
TIME"***

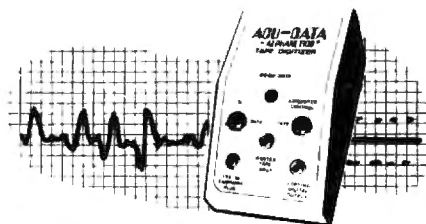

tape digitizer

✓ 113

*From a review in September-October 1980 Elementary Electronics. Reprints available.

At last there is a cure for TRS-80 tape clogging blues! For over three years, Alphatecs has been selling the TRS-80 Tape Digitizer, a proven hardware solution for your software problems. No longer need you juggle the recorder's volume control endlessly, trying for a perfect cload of a pre-recorded program. Just pop the tape into the cassette recorder, process the signal through our digitizer, and you're ready to RUN a perfect load!

Just check out the Tape Digitizer's features . . .

- Makes tape program loading virtually independent of volume control setting.
- Allows copying system and normal tapes without using computer.
- Makes a perfect digital copy of any tape without using computer, removing hum, noise, and cures minor dropouts.
- Cassette switch allows manual control of cassette recorder, independent of computer control.
- "GOOD DATA" indicator easily enables setting proper volume . . . doubles as a tape monitor.
- A.C. powered — no batteries to replace.
- Housed in a sturdy, attractive metal case.
- Completely compatible with Level I & II, also LOW speed (500 baud) Model III.

Feed your cassette to the Alphatecs Tape Digitizer and feed your computer the exact digital waveform the TRS-80 gave your tape. Get rid of your tape bugs today — \$69.95 postpaid to continental North America, or return within 10 days for a full refund!

alphatecs

Box 597 Forestville, Ca. 95436
24 hr. phone (707) 887-7237

COLOR COMPUTER

SPECTRAL ASSOCIATES, the LEADER in TRS-80 Color Computer software, presents the best in machine language, fast action, high resolution arcade games.

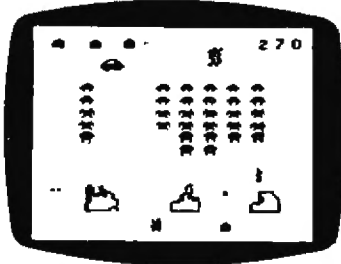

COSMIC INVADERS

The best invaders type game available. Complete with 16 skill levels, dynamite sound and 4 color hi-res graphics. Can you dodge the bombs long enough to blast the alien ship and invaders? Extended BASIC not required. 16K - \$21.95.

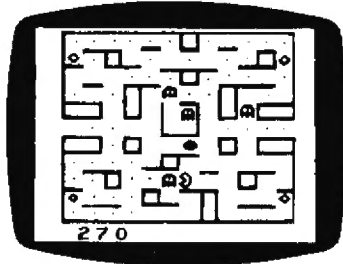

GHOST GOBBLER

An exciting version of the popular PAC-MAN game with power dots, 8 bonus shapes, super sound and 16 skill levels. Hours and hours of challenging fun. Does not require Extended BASIC. Joysticks. 16K - \$21.95.

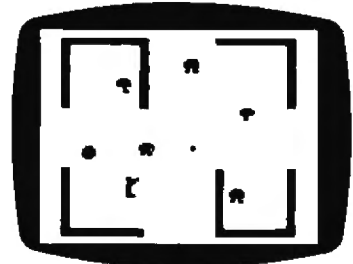

ROBOT BATTLE

Can you dodge the never ending horde of robots while avoiding the fatal touch of the Android? Realistic voices and 16 skill levels provide a tremendous arcade type challenge. Does not require Extended BASIC. Joysticks, 16K - \$21.95.

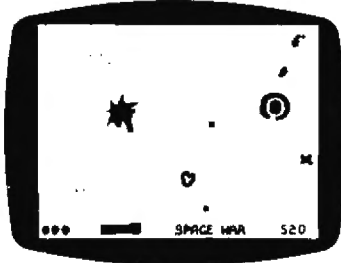

SPACE WAR

Maneuver your spaceship through the defenses of the Death Star for the killing shot while avoiding space mines, enemy ships and the gravity pull of the BLACK HOLE. Two color hi-res graphics - does not require Extended BASIC. Joysticks. 16K - \$21.95.

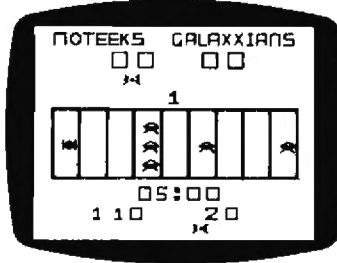

COSMIC SUPER BOWL

An excellent simulation of the popular handheld football games with a cosmic flavor. You must maneuver your player through a field of defenders. Five action skill levels. Does not require Extended BASIC. 16K - \$14.95.



GEOGRAPHY PACK

Great Geographical mind challenges. You must identify the country/state, capital, industry, etc. for the U.S., Europe, Asia, Africa and South America. Written in Extended BASIC. \$9.95 each, all 5 for \$29.95.

EXTENDED BASIC GAMES

- SPACE TRADERS \$14.95
Galactic trading game
- BATTLEFLEET \$14.95
Battle ship search game
- YAHTZEE \$12.95
Yahtzee type dice game
- LOTHAR'S LABYRINTH \$ 9.95
Word search game
- LASER ATTACK \$10.95
Defend cities from lasers
- SUBHUNT \$12.95
Submarine attack game

UTILITIES

- EDITOR/ASSEMBLER \$34.95
- SUPER MONITOR 19.95
- EPROM PROGRAMMER 89.95
(Program your own ROMs for the ROM PAC port)
- MAGIC BOX 24.95
Load MOD III Basic. Tapes into color computer

THE FACTS

At last a complete description of the "guts" of the Color Computer. Specs on all of IC's complete schematics, theory of operation and programming examples.

\$14.95

MEMORY EXPANSION

- RAMCHARGER**
 - For old style color computers
 - Extend memory from 16K to 32K
 - 100% compatible with Extended Basic
 - No soldering or modifications needed
 - Fits inside computer
 - \$79.95
- DYNOCHARGER**
 - For new style color computers
 - Extend memory from 4K or 16K to 32K
 - \$79.95

- LPRINTER VII DRIVER \$9.95
Send any graphics page to LPVII. Works in 4K, 16K or 32K machine. Does not need Extended BASIC and allows scaling of drawings

MACHINE LANGUAGE GAMES

- COLOROUT \$12.95
Fast action breakout game
- CROID \$12.95
Artificial intelligence game

KEYS OF THE WIZARD

Brand new super adventure filled with hundreds of rooms, glittering treasures and smart creatures which will follow you throughout the adventure. Plenty of tricks, traps and puzzles which change with each new game. Cassette save feature built in. Written in machine language. Extended BASIC not required. 16K - \$19.95.



SPECTRAL ASSOCIATES

145 Harvard Ave.
Tacoma, Washington 98466
(206) 565-8483

WRITE FOR COMPLETE CATALOG ✓119

ADD 3% FOR SHIPPING NO COD

VISA OR MASTERCARD ACCEPTED

COMMANDER 80

by Jake Commander

*"I'd like to start
by saying goodbye!"*

This is the first of a series of columns I'll be doing every month for *80 Microcomputing*, covering topics ranging all the way from software and hardware to my general opinions on whatever takes my fancy. This is an opportunity I've waited for—to be able to sound off and air some of my views.

I may take the opportunity to look at pieces of TRS-80 hardware or software, and pass along any tips I pick up as I go. As a technical consultant to Wayne Green Inc., I'm in a fairly unique position to acquire TRS-80 inside knowledge, so now I can share some of my acquisitions. I'll also bring behind-the-scenes magazine people and information into focus (although I may be strapped for words to describe scenes such as the spectacle of a whirling dervish named Dennis Kitzsch as he whizzes through the office causing pieces of hardware to cower in corners).

In short, this column will be a regular pot-pourri of TRS-80 facts, ideas and opinions. If anyone has any helpful pieces of information, I'll be glad to pass them on as space permits. If I see any new pieces of software that impress me, I'll pass along those impressions too, but I intend to keep the whole column on a much less formal basis than our review section.

Hello and Goodbye

I'd like to start by saying goodbye: Goodbye. I'm saying it not to you, but to Debbie Marshall, our Managing Editor for nearly a year now. She started as a sweet, demure copy editor who wouldn't say boo to a goose. After just twelve months on the job she had forged her way to the top, leaving the male chauvinist-dominated staff scratching their heads in astonishment. She'd said boo to all of us and subsequently demonstrated she had more than her fair share of ability in taking the helm of *80 Micro*. She's done a professional job and we're all going to miss her.

I'm beginning to feel like the old man of the mountains. That's three managing editors I've had the privilege of working with. Originally it was Jim Perry who helped found the magazine, developing it from its conceptual stage, then Mike

Commendul who took the magazine to a staggering 300-plus pages, followed by Debbie Marshall who has guided us to our current level of success. Now for my fourth managing editor. Soon a new era will begin under the aegis of Eric Maloney, who comes to us from *Microcomputing* magazine. Eric is an experienced journalist and an old hand as far as microcomputers go, so we're in good hands. Best of luck, Eric, old chap.

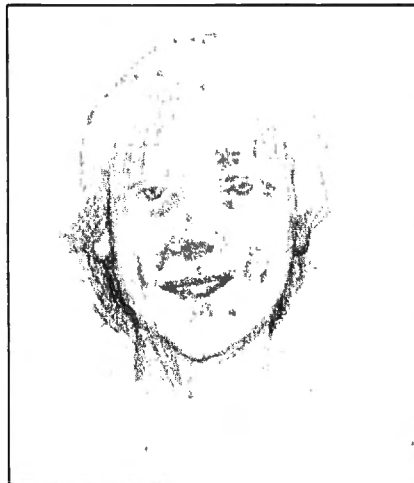

New Games

OK, just to get the ball rolling, I'll take a look at two pieces of software recently sent to me from Adventure International. Both are graphic-oriented games and should keep the TRS-80 arcade fanatics happy for hours on end.

Armored Patrol is my favorite of the two. In this game you're sitting inside an armored T-36 tank peering forwards from the narrow window. Enemy tanks and killer robots skulk around waiting for you to stumble across them. You move your tank by using two keys on each side of the keyboard, one for forward movement of that side's caterpillar track, the other for reverse. The tank can be rotated on a dime by placing one track in forward mode and the other side in reverse.

While you're doing this, you'd better be watching for those enemy tanks. They shoot with deadly accuracy and many a time I've been caught on the hop as a missile comes flying towards me with a screen-shattering crunch. Pointers on the screen help by hinting as to the turn you should make to find the nearest baddie. As often as not, though, the ratfinks shoot before you can see them and all you have to show for your effort is a smashed screen and one less tank.

As if that weren't enough, sometimes the cowards go full pelt and slink behind houses that are dotted all across the terrain. It's then up to you to maneuver behind the obstacle and blast the enemy with your high energy plasma missile before he gets you. Great fun.

The other game is good fun too, but it's not my favorite because I have a penchant for point-of-view type games where you sit in a simulated hot seat.

Eliminator gives you a split-screen side view of a scene containing gantries supporting energizers. These energizers must be worth having, because marauding alien hordes want them. The dastardly aliens actually help themselves, too, and lift off your valuable energizers without paying a bean. It's one of the worst forms of galactic felony I know, so naturally enough the job of their protection falls to the poor sucker at the keyboard.

As soon as you kick your ship into action you regret it; the world goes screaming by, full of space-meanies out to get the better of you. You can dodge, fire missiles and change speed all in an attempt to save your energizers. I want to know where they take them to; presumably there's a black market for these things and right now there must be a glut. I've lost so many of the darned things that they just can't be fetching much.

Both games are written in machine code and include sound. This is state-of-the-art stuff and they have taken their place in my game library. What a difference I see in the sophistication of games in my library since a mere two years ago! I can't wait to see what develops in the next two years. ■

News From KITCHEN TABLE SOFTWARE, INC.

by David Busch

"Accompanying the manual was 130 pages of errata covering virtually the entire manual."

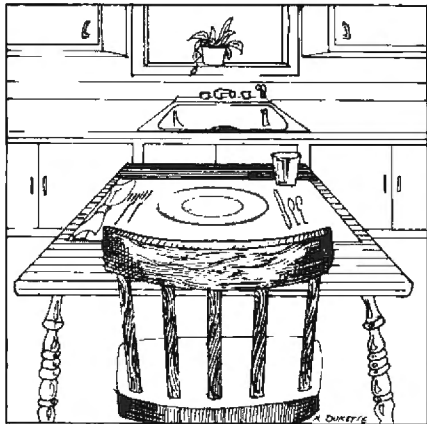

I mistook the disarray of loose parts inside my latest shipment from Kitchen Table Inc. to be the work of the delivery service until I read the packing slip. I was the lucky recipient of the first TLS-8E Home Assembly Construction Kit (HACKIT).

Kitchen Table had selected me to field test the new kit, no doubt due to my glowing reviews of their fictitious computer hardware, software, firmware and limpware.

What's unusual about HACKIT is even the novice kit-builder can construct a working TLS-8E Model I or, as the disclaimer on the box notes, one that works as well as any other TLS-8E Model I.

Kitchen Table is familiar with my hardware qualifications. It reasoned if I could build the kit, it could be safely marketed to the public and to children in grades K through six as a science fair project.

A summary of my electronics expertise: I once wired a receptacle that, every time a three-pronged plug was inserted, turned on all the lights in my home. Until recently, I thought a thermistor was something you keep cigars in.

The KI kit can be built with ordinary household tools—screwdrivers, 25-watt soldering iron (or propane torch), 30 MHz dual trace oscilloscope.

Other useful gadgets to have on hand during assembly include a signal tracer, audio oscillator, digital multimeter, 30 MHz frequency counter, RF oscillator with 320 KHz to 220 MHz range, graphic equal-

izer and SWR meter. I don't have any of these, but KTI provides instructions for re-wiring your home tv, electric can opener or stereo set to provide many of the same functions.

Many of the more exotic devices can be ordered from KTI completely assembled or in their own HACKITS.

I decided to ignore the tests and calibrations I couldn't perform with the equipment I had at hand. After all, how much could a microfarad here or there matter in a sophisticated computer system?

The assembly manual provided by KTI is a well-written, 137-page volume with illustrations and step-by-step instructions. Accompanying the manual was 130 pages of errata covering virtually the entire manual. Give KTI an A-plus for thoroughness.

The first step in assembly is to find a clean or dry place. Some of the kit's complementary metal oxide semiconductor integrated circuits are very touchy. Kitchen Table recommends wearing copper bracelets on your wrists, ankles and waist. The bracelets should have a one megohm resistor wired to them and cables of no. 8 wire extending to the nearest drainpipe. A two-inch thick rubber mat is provided to place under your chair.

Carpeting is forbidden near the construction site. All long-haired cats, silk handkerchiefs, glass rods and rubber balls should be cleared from the area. To avoid static build-up from clothing, you should do as much work as possible in the nude, but be very careful while soldering.

An alternative to all this would be to use normal precautions with the exception of lowering the room lights. As you pick up the integrated circuits, notice if a tiny blue spark flies from your hand to the part. If so, and you hear a crackling sound and smell ozone afterward, expect trouble during the testing stage.

Kitchen Table is to be commended for its innovative approach to kit-building. There are almost no printed circuit boards in this kit! Instead, much assembly is done on perfboard with clips fitting snugly in the holes. A tube of Superglue is supplied to ensure tight, permanent connections.

A spool of no. 10 wire is also provided. I'm told this extra-thick wire makes it easier for the electricity to flow from one portion of the circuit to the other, and eliminates many hardware errors. Less advanced computer designers, such as those building the CRAY-1, have resorted to clumsy methods such as supercooling components to improve conductivity. These klugey methods pale in comparison to KTI's elegant "thick wire" solution. Bravo, KTI!

Assembly of the computer is divided into 123 major components, 1024 sub-components and 32,767 steps. Heat-sealed plastic bags contain the components needed for each step. Thirty-two thousand seven hundred sixty-seven bags are a lot. Fortunately, they're all numbered. Unfortunately, in Sri Lankan.

To protect their patent (pending) on the TLS-8E Model I, it was necessary to disguise components. All ICs, resistors, capacitors and diodes had their identifying numbers scratched off. And because of the bagging scheme, there were no colored bands on the parts. This made it difficult to determine which way to insert the resistors into the boards. Does anyone know an easy way to determine the polarity of a resistor?

Without identifiers, it is also difficult to replace parts affected with infant mortality. This condition arises when parts are released from the factory in a premature condition. They may look healthy, but once powered up, they fail to take that all-important first breath and expire in a puff of smoke.

I had to phone KTI for replacement of three dead ICs. Two were typical infant mortality cases; the third was swatted by my wife, who thought it was a bionic spider.

Delivery of the components took nearly three weeks, despite the fact I live only 13 miles from KTI headquarters. Better quality control and more careful assembly are needed here, although three imperfect components out of 65,535 is commendable.

Assembly of the kit took 23 weekends, most of my vacation and the better part of my accumulated sick leave. Some delays

DISK DRIVES

FROM: **SIEMENS**
NEW PRICES
 EFFECTIVE 4-1-82

HARD DISKS & FLOPPIES FOR YOUR HEATH, RADIO SHACK, OSI & S-100 SYSTEMS

ATTENTION RADIO SHACK MOD I, MOD II AND MOD III USERS

Floppy Disk Services has disk drives for all your needs. Our 5 1/4 inch drives are tops for the Mod I. Our 8 inch drives are perfect for the Mod III! And our Dual sided 80 track units are perfect for the Mod III! All drives are brand new factory warranted.

5 1/4" DISK DRIVES (MODEL FDD-100-5b) for Heath, RS MOD I, S-100, N. Star & more

SIEMENS 5 1/4" drives are single sided, single or double density drives that are designed for years of trouble free service. These are the floppy models which other companies charge 15 to 30 dollars more for. The 5 1/4" is the exact same one used in the HEATH systems, but check our price! NOW \$240.00

5 1/4" WITH CASE AND POWER

Our 5 1/4" drives are also available in system packages. One 5 1/4" floppy in case with power supply tested \$285.00
 2 drives in dual case..... \$585.00



80 TRACK - DOUBLE SIDED 5 1/4" for Heath, CDR, RS MOD III, S-100 & more

A new product from SIEMENS. This beauty is a new entry to the Floppy market. Get up to 800K Bytes storage on a 5 1/4" diskette. Model #FDD-221-5..... NOW \$350.00 ea.

PACKAGE DEAL 80 TRACK 5 1/4"

1 dual sided 80 track drive (in case with power supply) \$395. Two 80 track double sided (in one enclosure) \$795.

8" FLOPPY DISK DRIVES (MODEL FDD-100-8d) for Heath, OSI, S-100, RS MOD II & more

SIEMENS 8" drives are single sided, single or double density with simple power requirements. +24 and +5 VDC. It has automatic diskette ejection and a fail safe interlock that prevents the door from closing on a partially inserted diskette. The track to track time is as fast as 4ms. These drives are completely compatible with your MOD II, OSI, and many other systems..... NOW \$340.00 ea.

8" SYSTEM PACKAGES

One or two 8" SIEMENS drives with cabinet (choice of vertical or horizontal) power supply, all power connections, manuals and fan. A beautifully functional package built only of the best grade components. Available fully assembled and tested for \$100.00 more.

Single 8" drive in dual cabinet..... (data cables extra) \$650.00
 Dual drive package..... (data cables extra) \$980.00

ATTENTION HEATH H-88, 89 OWNERS

HEATH owners, we now have the CDR controller card that allows you to use our 8" drives on the H-88 or H-89 computers! You may mix any combination of 8" or 5 1/4" drives and also change your system to soft sectored formatting! Mix any combo single sided, double sided, single density or double density. We even include the zero origin prom. As a special offer we are giving you ALL necessary components with this system, even the patch for C/PM!

A complete dual 8" system for the H-88 or H-89 \$1450.00
 Dual 5 1/4" 40 track system with controller \$1050. Dual 5 1/4" 80 track system with controller \$1250.

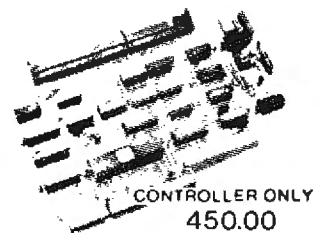

CONTROLLER ONLY
 450.00

WINCHESTER TECHNOLOGY HARD DISK SYSTEMS

5 or 10 MEGABYTE Hard Disk systems for your HEATH H-88, 89, Radio Shack Mod I, II or III, Apple, IBM, or any S-100 system! You get a 5 or 10 megabyte formatted hard disk, power supply, cabinet, all interfacing cables, and CP/M boot loader. Most of all its all factory preassembled and tested, burned in and ready to run! You even get a real time clock (except HEATH). Built only of commercial grade components..... JUST \$2400. 5mb and \$2700. 10mb

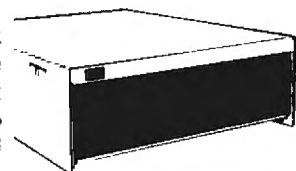

quantity discounts available some of the 8" packages require assembly...we carry parts for siemens



PAYMENT POLICY

We accept Mastercard, Visa, personal checks & MO. We reserve the right to wait 10 working days for personal checks to clear your bank before we ship. All shipping standard UPS rates plus insurance NJ residents must add 5% sales tax



FLOPPY DISK SERVICES, INC

C.N.5212

PRINCETON, NEW JERSEY 08540

✓ 267

PHONE INQUIRIES WELCOME 9AM to 5PM (ET)

609-771-0374

PRICES & SPECIFICATIONS SUBJECT TO CHANGE

MOD II, CP/M are trademarks of Tandy and Digital Research respectively.

KITCHEN TABLE SOFTWARE, INC.

were caused by my errors. While there are only two printed circuit boards in the kit, I soldered most of the components on the wrong side on my first attempt. That "flash" I trimmed off the IC sockets turned out to be contacts. I brought a few other minor problems under control with a fire extinguisher.

Major components in the kit include a power supply, video driver board, Z-79A based terminal logic board, Z-79A CPU board, cassette tape interface board, floppy disk controller, RF modulator circuit, printer interface and automatic garage door opener.

This last feature is a standard enhancement. Apparently KTI got a good deal on some electronic equipment it's trying to get rid of.

The construction manual explains what all those components are used for. I strongly recommend you read it. I skipped over that part because it contained boring discussions of memory mapping, direct memory access and a lot of other stuff I don't understand too well.

I built the power supply first because the manual said I had to. It was simple

enough. It involved some filter capacitors, diodes, power transistors and an eight-pound heat sink. The power supply is rated at 1250 watts—large enough to heat an average-sized room in winter. I put it together in eight hours, which includes two hours waiting for the soldering iron to heat up. (I had forgotten to plug it in.)

The video driver board came next. Assembly was much quicker, mostly because I stopped being fussy about placement of the parts. Attention! The "theory" part of the instructions contains a lot of complicated terminology about horizontal deflection and vertical sync. Pay attention. You may be able to apply this knowledge to fixing your color tv some day.

The terminal logic board is a snap. It comes prewired from the factory. Kitchen Table got some Heath Z-89 boards on closeout, discarded the primitive Z-80 chip and substituted the Z-79A in its place.

The CPU logic board was another matter. Next to the automatic garage door opener, it was the most difficult component in the HACKIT to assemble. I built the 32K model and had 16 memory chips to insert. It took me nearly three weeks to

decide which chips to insert in which memory sockets.

Oddly enough, when I finished assembling the kit and plugged it in, it gave off a loud crackling sound and refused to work at all. Fortunately, KTI offers a kit repair option. For \$1450 (or \$50 less than the current price of a TLS-8E Model IV), the company will fix any botched assembly jobs. A bargain, if you ask me. ■

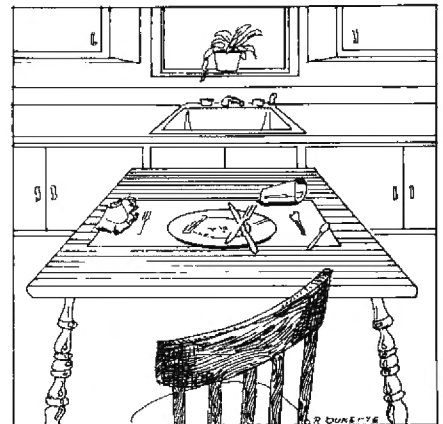

PRICES LOWERED AGAIN! (THOSE WITH \$ SIGN) **RIBBON SALE** EXACT REPLACEMENTS, LONG-LIFE, HEAVY INKING

Good This Month **RADIO SHACK-CENTRONICS-EPSON-ANADIX-BASE 2-HEWLETT PACKARD-MALIBU-IBM PRINTERS**

PRINTER MAKE, MODEL NUMBER (Contact us if your printer is not listed. We can probably RELOAD your old cartridges.)	RIBBON SIZE Inches by Yards	INSERTS EZ-LOAD™ EXACT REPLACEMENTS made in our own shop feature LONG-LIFE and HEAVY INKING. Our instructions: DROP IN, NO WINDING! \$/* CARTRIDGES NOT INCLUDED	RELOADS You SEND your used CARTRIDGES to us. We RELOAD them for you. \$/*	NEW CARTRIDGES (from the various manufacturers. Subject to availability.)* \$/*	SILVER DOLLAR WIND TO LOAD WHY DO WE SELL THESE? This is the type ribbon you get if you order from our fellow advertisers. We sell them for less since we make them ourselves. Do you really like the mess and inconvenience of unwinding and dumping this type ribbon into a wastebasket or out on a newspaper and/or winding it into your cartridge? We don't know why these are being sold. Computers should simplify your life, not make it more complex just to save a few pennies. You are welcome to order these if you cannot afford our EZ-LOAD™ INSERTS, RELOADS, or NEW CARTRIDGES. BUT BEWARE! You now know how to avoid disappointment. One more caution: be sure to check the length of any ribbon BEFORE you buy it. For instance, an MX-100 ribbon should be 30 yards long, not 20 as in the MX-80.
ANADIX 9000 Series	1/2x30	21/3 78/12	10/1 \$9/2 or more	* *	
BASE 2	1/2x20	18/3 66/12	9/1 \$8/2 or more	* *	
CENTRONICS 7-MEG 702/703/704/753	5/16 x 70		11/1 10/2 or more	\$25/2 \$72/6 \$140/12	
HP-MALIBU 2608-2631 RADIO SHACK DAISY WHEEL II Carbon Film (26-1419)	3/4x60 1/4 x 145	\$25/6 \$48/12 \$270/72	20/1 \$18/2 or more	* *	
COLORS Red, Green, Blue, Brown	1/4 x 130	\$30/6 \$58/12 \$324/72	18/3 or more	\$21/3 \$82/12 \$480/72	
Long-Life Fabric (1449)	1/4x25	\$24/3 \$47/6 \$90/12	9/1 \$8/2 or more	\$20/2 \$58/6 \$112/12	
LP II-IV 700 Zip-Pack (1413) 730/737/739/779	9/16 x 16	13/3 48/12			
LP III-V (26-1414)	1/2x16	\$18/3 \$66/12	9/1 \$8/2 or more	25/2 75/6 150/12	12/3 44/12 252/72
LP VI-VIII (26-1418)	5/16 x 12	\$17/3 \$62/12	9/1 \$8/2 or more	22/2 66/6 132/12	11/3 40/12 228/72
LP VII (26-1424)	WATER LOOP			16/2 48/6 96/12	
EPSON MX 70-80 IBM	1/2x20	\$18/3 \$66/12	9/1 \$8/2 or more	\$22/2 \$60/6 \$108/12	12/3 44/12 252/72
MX 100	1/2x30	\$21/3 \$78/12	11/1 10/2 or more	* 46/2 *	18/3 66/12 360/72

SEND CHECK, MONEY ORDER, or COD (\$2.00 UPS) TO:

BCCOMPCO ✓152
800 SOUTH 17 BOX 246
SUMMERSVILLE MO 65571
417 932-4196

WE PAY SHIPPING ON PREPAID ORDERS. PLEASE INCLUDE STREET ADDRESS FOR UPS DELIVERY. NON UPS, MEXICO, CANADA, ALASKA, HAWAII, ADD \$1.00. FOREIGN ADD 10%, US FUNDS ONLY. NET 30 ACCOUNTS AVAILABLE. CALL.

WORRIED ABOUT ORDERING BY MAIL? Relax. We've been in business for many years and can please the smallest and largest account. You receive some of the finest ribbons available made of our own exclusive IMAGE PLUS™ fabric and carbon film. Our ribbons fit your printer exactly. (COMPARE, but BEWARE!) We order all our competitor's products and are amazed at what we get. Have you ever received a new fabric ribbon you had to unwind and dump out on the table before you could use it? We have. Or, carbon film inserts that had no end-of-ribbon sensor? Or, 7-meg cartridges with only HALF enough ribbon at full retail? Our only business is RIBBON manufacturing and distribution. We use the latest state-of-the-art production equipment and are blessed with a fine, dedicated staff. We fully guarantee all our products because we make them ourselves. You must be completely satisfied, period. Our ribbons are made fresh daily and shipped within 24 hours. Write for our brochure and newsletter "INK SPOTS". Dealers welcome.

Bill Coe President

Volume 1 **MODEL II 8" GAME DISCS** Volume 2
Biorhythms, Trap Ugly, Bingo
Rip Cord, Yacht Sea \$25.00 each Towers, Blackjack
Concentration & 4 More Farkle, Pony & 3 More

KUDOS: (Unsolicited comments from some of our users.)
"Thanks again for your excellent product and service."
"EZ-LOAD is terrific! I'll never wind a 'silver dollar' again."
"You people do good work. Thank you." "The previous order was very good."
"We received your ribbons the next day. We couldn't believe it!" "We couldn't either."
"The ink on our last order (LP V INSERTS) was much better than 'store-bought' ** cartridges."
"I have appreciated the quality, service/turn around on orders, and clear instructions of your products."
"We just went through three of your (DW II) reloads, and there's no question they are better than the originals!"

USERS:
Doctors, lawyers, accountants, hospitals, schools, universities, U.S. Armed Forces, small and large corporations, state and federal agencies, Radio Shack Dealers, and a lot of just plain folks. Need a recommendation in your area? Call us. We have users all over the world, in Japan, Australia, the Philippines, Italy, Canada, Mexico, Sweden, England, Columbia, Kenya and many other countries.

Professional/Scientific

WORD PROCESSING

Since introducing QWERTY 3.0 in September, people have been calling to ask if we were making ludicrous claims. The answer is NO! QWERTY 3.0 does all we claim it does and more! No other software of this type can match QWERTY 3.0.

$$T_1^2 = \frac{\sum_{i=1}^n \frac{\alpha_i \bar{\alpha}_i + \mu^2 \pi^2}{\lambda_i \psi_i - \rho^2 \theta^2}}$$

It is the best. Period. We guarantee you will agree! If for some reason you find that this program does not meet your needs, return the entire package within 14 days for a prompt and cheerful refund.

(Actual QWERTY text above)

SOME FEATURES OF QWERTY 3.0

1. Automatically prints in proportional print, with a suitable format. Transitions between the three print styles are easy, including all expanded print modes. 2. QWERTY 3.0 adds 75 new symbols, including upper and lower case Greek letters, mathematical symbols such as integrals and summations, arrows, brackets, and probability symbols. 3. Any character can be used as a subscript or superscript, even simultaneously. Carats, bars, and tildes can be placed over any character, with precise position control. 4. Underlining, with or without underlining of spaces, including long ratios and mathematical expressions. 5. FOOTNOTES can be placed on any page so that they remain on the desired page, even if text is inserted later. 6. TABLE commands enable positioning of the print head anywhere on a line. Invaluable in printing neat mathematical layouts, tables, columnar material, etc., in proportional print. 7. PRETTY commands allow printing of repetitions of a chosen character. When combined with TABLE, decorative borders can be produced with ease. 8. FOLIO format produces output in two or three columns per page, in either proportional or 16.7 cpi mode. Ideal for newsletters. 9. Supplies a third output mode, in which only SCRIPSIT commands are obeyed. Allows printing of special QWERTY commands for future reference. 10. PAGE END indicates where pages will end, and the page number, without printing the text. One can prepare an almost error-free document without ever using paper. 11. Correction of SCRIPSIT's errors and inconveniences, extensive documentation, and much more!

QWERTY 3.0 requires a TRS-80 Model I or Model III, at least one disk drive, a copy of SCRIPSIT, and one of the printers specified below. When ordering, **please specify** which model computer, number of drives, and printer you use. For cautious buyers, we offer the manual (over 70 pages) for \$10. When you decide to buy QWERTY, we will credit the full manual price.

QWERTY 3.0
(for Lineprinter IV, Centronics 737, or Centronics 739) complete package \$74.95
DAISY (for Radio Shack Daisy Wheel II) complete package \$74.95
QWERTY 3.0 Manual (specify printer) \$10.00



MED SYSTEMS SOFTWARE
P.O. BOX 3558 CHAPEL HILL, NC 27514
TO ORDER, CALL 1-800-334-5470

We've grown on you

NEW!



Your Mysterious Adventures Begin With Arrow of Death, Part I.

By Brian Howarth

The first in our brand new, exciting Mysterious Adventure Series with all the popular features of TRS-80 Adventures *plus* a new, challenging mental approach. In Arrow of Death, Part I, a mysterious blight has fallen on your land. It seems to come from the Golden Baton, once good but now a source of evil incarnate. Rain has destroyed the crops, friends are at each other's throats, despair and hatred fill the hearts of the people. The King implores you to aid his sorcerer, Zardra, in banishing this evil from the land. You agree, and the adventure begins. You'll face constant danger, possibly death—but you'll also have the opportunity to perform heroic tasks.

All Mysterious Adventures have a "save the game" feature. Arrow of Death, Part I is complete in itself... but we think you'll find it so challenging, you'll want to continue with Part II. Other Mysterious Adventures will include *Time Machine* and *Golden Baton*—all written to give you many hours of gaming pleasure.

16K Tape
or 32K Disk.
TRS-80 I & III **\$19.95**
plus \$2.00 shipping and handling



Everest Explorer

By William Godwin & Don Knowlton

Will you be one of the daring few to make it to the pinnacle of Mount Everest? Or will you succumb to the lack of oxygen, the unexpectedly rough terrain? You, as the leader of the Everest expedition, will have to choose the route, choose the timing, make sure your climbers are well-rested, set up a chain of camps and, if you reach the summit, get your followers back down to base camp. You'll have to manage money, climbers, Sherpas, tents, oxygen, food and fuel. Danger lurks at every step—can you get to the summit and return? "Save the game" feature on disk.

16K Tape
or 32K Disk.
TRS-80 I, III, **\$19.95**
Color Computer and Atari
plus \$2.00 shipping and handling



Lost Colony

By David Feitelberg

You are the Economic Manager of the world's first space colony. The next support ship from Earth isn't due for another 15 years and you have instructions either to make things go better or get out of office in shame. You must assure the survival of this struggling space colony—it's all up to you. You'll be presented with the human, natural and industrial resources of the planet. You must allocate labor, explore new territories, decide on production quotas, determine pay scales and taxes for the most productivity—you're armed with maps and charts. 10 levels of difficulty. "Save the game" feature on disk.

16K Tape
or 32K Disk.
TRS-80 I & III **\$29.95**
and Atari
plus \$2.00 shipping
and handling

With Acorn Programs, Your TRS-80 Does Things You Wouldn't Think Possible

Our sophisticated programs make sight and sound seem simultaneous—you're never disappointed when you select a program from us. *And*, our customer service is unparalleled in excellence.

Acorn Has a Program For Everyone

Whether you want games, adventure programs, word processing enhancement programs, teaching programs, utility programs that help serious programmers improve their programming and get more out of their computers... Acorn has them all.

Because Our Programs Deliver What They Promise.

Instant Sort/Search Database

By Gordon Hatton

An easy-to-use fast information manager for home, personal or small business use. Even a novice can make full use of this program and it's extremely "user-friendly" in helping minimize operator errors. ISS comes in 3 parts: (1) lets you create, examine and save your custom-formatted data base; (2) sorts and searches the data base so you can pick out and print just the information you need; (3) provides powerful editing commands so you can modify and update your existing data files. Also includes "DEMO", a 5000 record demonstration data file that lets the first time user familiarize himself with the command set. ISS handles both alphabetic and numerical data in a variety of combinations.

16K Tape

or 32K Disk. **\$49.95**
TRS-80 I & III
plus \$2.00 shipping and handling

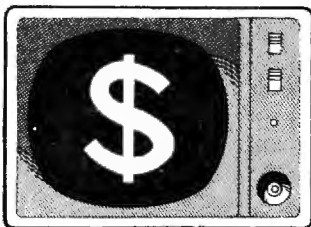

Money Manager

By Andrew Bartorillo

In today's economy, we all need to monitor our expenses more closely. **Money Manager** will help you keep track of your income and expenses and give you an easy way to manage your budget. You define the categories according to your needs, including tax-deductible expenses... a great help at tax time. You can also reconcile your checkbook with the bank's balance. Full lineprinter capability allows you to print items by each category.

32K (Minimum) Disk

TRS-80 I & III **\$39.95**
and Atari
plus \$2.00 shipping and handling



Your Family Tree

By Chuck Acree

Whether you're a professional genealogist or simply interested in your own ancestors, **YOUR FAMILY TREE** lets you avoid the limitations of paper-based charts. This program sets up your data base quickly and easily—holds name, date and place of birth, marriage and death information for each ancestor, plus a comment line. You can get a complete "pedigree" from any selected family member; or a 3 generation ancestral chart displayed or printed showing the number of known ancestors beyond each branch of the tree. The program will also display an outline map of the U.S. showing migration across the country. Use full or partial information to get full search capabilities by any key field.

16K Tape

or 32K Disk. **\$29.95**
TRS-80 I & III
plus \$2.00 shipping and handling



Language Teacher

By Cindy & Andrew Bartorillo

Teachers, students, and those who just want to learn a new language—Acorn's **Language Teacher** gives you your choice of French, Italian, German or Spanish. Use these programs at home or in the classroom. Students like this new way of learning and/or reviewing a previously learned language. Teachers can free themselves from tedious preparation of vocabulary lists and writing quizzes. Each **Language Teacher** offers hundreds of word combinations, verb conjugations and phrases. Choose the drill topic and foreign language-to-English or vice versa. Option for multiple-choice answers plus retest on missed items. Gives running percentage of correct answers.

Available: French, Italian, German I & II, Spanish I & II.

32K Disk. **\$29.95**
TRS-80 I & III
plus \$2.00 shipping and handling



Acorn
Software Products, Inc.
634 North Carolina Avenue, S.E. Washington, D.C. 20003

We've Grown On You.

And, our selection of programs for your TRS-80 I & III expands with a new program monthly.

Shop Acorn
by mail!
Mail this
coupon today
for your
FREE Acorn
catalog.

Mail to: **ACORN SOFTWARE PRODUCTS**
634 North Carolina Avenue, S.E.
Washington, D.C. 20003

NAME _____
ADDRESS _____
CITY _____ STATE _____ ZIP _____



Making sights and sounds to thrill and please.

Computer Creationists

Jay Rose
480 Boylston Street
Boston, MA 02116

I received a call at my recording studio last December from a customer requesting a special sound effect:

"Jay, we need the sound of a soda machine."

"No problem."

"Since we'll never see the machine, the sound has to be immediately recognizable."

"I am sure we've got something."

"It is the kind that squirts the soda into a little cup, not the kind with the cans."

"We can make that work."

"Oh yeah. . . the machine is out of cups."

This vending machine sound effect was used in an elaborate training tape for a multinational corporation to help sell word processors. The effect was created from recordings of a pay telephone, a can opener, a washing machine, a fire hose, and a studio synthesizer. And we probably could not have produced it at all without our TRS-80.

There are about a hundred sound and video studios in this country specializing in special effects. A lot of these effects are used in films (not just the "Star Wars" kind; almost every Hollywood film uses sound effects and camera tricks to make actions seem more real).

Most of this manipulation, however, is for broadcast use. Radio, tv and cable need more material than Hollywood could ever turn out alone. The fact is, more people will probably see a particular commercial than will see most entertainment films in a theater or on tv. Production budgets—dollars per finished minute—are usually bigger in commercials than in films. Millions of dollars of a product's sales can be involved.

You have seen commercials with people walking through data networks, bluejeans flying across a city, or pictures of a bicycle coming to life. I've been involved with a number of them, and they do help sell products.

The Art of Commercials

Dealing with dreams—creativity—becomes a very competitive, high-pressure business. Yesterday's bold new technique is today's obvious trend, and tomorrow's obsolete solution. Most creative production companies stay relatively small—like most microcomputer companies—and to keep ahead, they invest heavily in the latest digital equipment: image squeezers, pitch shifters, microprocessor-controlled cameras, and tape recorders. Many are also using microcomputers, specifically the TRS-80 and the Apple.

Micros are popular for two reasons: They are affordable and they are flexible. Com-

panies in this volatile field do not have to commit more than a few thousand dollars to determine a computer's worth. Basic is such an easy language that production executives can design programs for specific applications quickly.

Creativity is what a production company sells. The soda machine sound effect required an unusual solution to a problem that may never come up again: What real-life effects suggest the sound of "running out of cups?" We have thousands of effects in our library. Without our computer, finding the ones we needed ("Do I look under washing machine or water spraying?") would have taken far too long. There would be too many blind alleys and the creative process would have been slowed considerably.

People Are Multi-Processors

Psychologists have discovered most people do their creative and logical thinking differently: The brain acts like two separate computers. The left side of your brain specializes in logical functions, number crunching and string manipulation, if you want to think of it that way, while the right side works more like a random generator, constantly coming up with new solutions and seeing how well they match the real world.

Psychologists have also discovered that it is almost impossible to use one half of your brain to its fullest capacity while also trying to use the other half. You cannot write a good short story while trying to debug a program. And despite what the IRS says, it is very difficult to invent a deduction while you are adding up columns on your 1040.

Computers, in a business like mine, free people from worrying about filing systems, production budgets, or script typing. I am selling creativity, and computers let me have more to sell.

Computers in the Studio

Oddly enough, business applications are usually the last ones to go on line in a production company. Very few studios use canned ledger or billing programs since their business needs are usually so simple. (Besides, clients don't like to think of creativity as being computerized.) The pro-



The Synclavier

"I believe Super Utility or Super Utility Plus should be present at every serious TRS-80 disk installation."

(We didn't say this; Paul Wiener did in 80 Microcomputing, Jan. '81. . .but we sure agree with him!)

Get Yourself a "Super" Utility from the most powerful software vendor.



NOW AT SPECIAL PRICES:

Super Utility*

- Mod I, single density only
- 24K machine language
- Zap
- Purge
- Format
- Special format
- Format without erose
- Disk copy
- Special disk copy
- Tape copy
- Disk repair
- Memory utility
- Protected disk
- MORE
- \$29.95
(Reduced from \$49.95)

*While they last!

Quick Fix*

- Mod I, single density only
- Zap
- Purge
- Format
- Format without erose
- Copy
- Disk repair
- Recover killed files
- Memory utility
- TRS DOS, New DOS + (2.1) only
- MORE
- \$19.95
(Reduced from \$34.95)

*While they last!

SuperUtility Plus

You heard about it! You read about it (80 Microcomputing). Now get the "cadillac" at a special price! Compatible with Mod I, and Mod III, and all the current operating systems! Copy files from any DOS to any DOS, Mod I or III, without converting!

- Zap
- Purge
- Format
- Special Format
- Format without erose
- Disk copy
- Special disk copy
- Tape copy
- Disk repair
- Memory
- File Utility Configurable System
- MUCH MORE
- Mod I & Mod III on Same Disk
- \$49.95
(Reduced from \$124.95)

Dealers! Place your orders now at this special price!

POWERSOFT
(c.a)

11500 STEMMONS EXPRESSWAY, SUITE 125
DALLAS, TEXAS 75229
PHONE (214) 484-2976
MICRONET 70130.203

✓61

DEALER INQUIRIES INVITED



POWERSOFT IS A DIVISION OF BREEZE/QSD, INC.

Shipping is included in sales to Canada & U.S.

FOREIGN ORDERS ADD \$10

“...play an audio type... twice as fast and not affect the frequency range of the voice or the musical key.”

duction companies that are using computers for this frequently use a service bureau, with or without an onsite terminal. On the other hand, if some enterprising software house wanted to sell me a TRS-80 studio business or talent payment program, I would probably buy it.

Dedicated computers are used in many studios for specialized applications, particularly signal processing. While general purpose micros like the TRS-80 may be too slow for this purpose, microcomputer chips, including the TRS-80's Z80, are frequently built into equipment.

Time Control

Perhaps the most important new use for this kind of computing lies in the area of time manipulation. Timing is critical in a commercial: A 30-second television spot can't be as much as a tenth of a second over its allotted time. Playing the film or video faster to save time causes synchronization problems, and makes the actions look like an old-time movie. Playing the sound track faster makes everyone sound like Mickey Mouse.

A dedicated computer called a time compressor has become popular in the last year or so. It allows you to play an audio tape up to twice as fast as it was recorded, and at the same time not affect the frequency range of the voice or the musical key. These devices sample the signal between thirty

and forty thousand times a second and write the digitized value into RAM. At the same time they read out of RAM at a faster rate. Complicated algorithms steer the read and write pointers around so they never run out of memory.

Speeding up a videotape deck to make a tape play faster causes interference to the picture because the television set no longer scans in synchronization with the input signal. This isn't acceptable in a commercial, and a different method is sometimes employed to save time: computer-assisted editing.

Television broadcasts 30 complete pictures a second. Your eye blends these frames together into smooth motion. A few years ago The Society of Motion Picture and Television Engineers proposed a standard method to number each of these frames with a distinct code. The method, called "SMPTE code," is similar to the audio code a TRS-80 uses to record programs or data on a cassette recorder. Virtually every television station, major video house, and a number of audio production companies use SMPTE code to keep track of where they are on a reel of tape.

Dedicated micros generate the code, read the code, and act on a tape editor's instructions to go from one scene to another. The programs for these computers are usually carried in PROMs, and the computers themselves can be very elaborate.

The SMPTE computer in my studio uses four 6809 CPU chips talking to each other. Its programming is so sophisticated it doesn't even read code to find out what frame it's on. It guesses, based on how much tape is on the reel, and then reads the code to see how much to adjust its next guess. This allows me to instruct the computer to go from one end of a reel of a tape to the other, find a specific sound effect, transfer it to a master tape in precise synchronization with a television screen, and then wind back to where it started... all while I take a sip of coffee.

Videotape is edited by transferring scenes from one reel of tape to another, rather than by being cut and spliced together the way film is. This process lends itself beautifully to computerization. Using SMPTE-based computers, a television producer can trim the length of each scene, a thirtieth of a second at a time, until a commercial or program is the right length and the action flows smoothly. Almost every serious videotape production is now assembled under computerized control.

Getting Away from the Real World

Much of the animation, type and special effects you see on television is created by computer. Freeze-frames, animated graphics, and other effects all take place by moving tiny elements of the scene around in an enormously large memory, frequently using the specialized applications of a stock mini-computer.

Character generators, similar to the TRS-80 but with finer resolution, are also used in commercial production. You have probably seen computer-generated type on news or sports programs. These same devices can now animate type, move slogans around the screen, and even generate custom logotypes. One production company uses an unmodified Model I to type information about their commercials directly onto the videotape.

Digital computers synthesize music much better than conventional analog ones. A Vermont firm, New England Digital, manufactures a very fast minicomputer connected to a piano-like keyboard. The Synclavier can make the sound of virtually any orchestral instrument (or the entire orchestra at once) by digitally analyzing an input signal, storing the information on a five-inch floppy disk, and then rebuilding the audio waveform while the musician controls pitch and dynamics from the keyboard. Sounds can also be defined or modified from the control panel to generate



Eventide's spectrum analyzer

DAISY WHEEL

By SMITH-CORONA

SAVE \$500⁰⁰

...and more over other popular
Daisy Wheel Printers.

- 120 WORDS PER MINUTE
- FRICTION FEED
- CHANGEABLE DAISY WHEEL TYPE FONTS
- CENTRONICS PARALLEL or RS232 INTERFACE

You Pay Only **\$745⁰⁰**

Rainbow™

P & P CORPORATION

P.O. BOX 762 • HADDONFIELD, N.J. 08033

✓ 264

TOLL FREE
ORDERS ONLY

800-257-6170

in New Jersey 609-428-3900

DAISY WHEEL by SMITH-CORONA

Enclosed is my check for \$745⁰⁰*

- Visa Master Card Check
 C.O.D. Wire Transfer (less 2%)

Credit Card No. _____ Exp. Date _____

Name _____

Address _____

City _____ State _____ Zip _____

Phone (____) _____

* No charge for shipping
No charge for Credit Card Orders
New Jersey Residents add 5% Sales Tax

Dos helper

- The features your dos doesn't have
- Fast ram spooler
- Type ahead
- Route to disk
- Compare files
- File format conversions
 - Add and drop line numbers
 - Word processor to EDTASM
 - Unpack Basic programs
- Append object files
- Model III TRSDOS directory
- Neat listing of packed Basic programs
- Designed for Newdos80.
Works with any dos
- Only \$19.95

Tatum Labs
P.O. Box 722
Hawleyville, CT 06440
(203) 426-2184

✓ 335

"So we plunked down some money for a one-size-fits-all disposable computer, the TRS-80."

waveforms that don't exist in any orchestra.

The Synclavier is a little bit like the music synthesizer programs available for the TRS-80, only much faster and more precise. Many commercials and made-for-tv movies are not using live musicians at all; it is cheaper and faster for the composer to play all the instruments on the computer. There are also creative advantages for the composer to be able to write a line and immediately hear it played on the different instruments. Synclavier's optional printer can even analyze what the composer is playing and write it out in standard musical notation. (*The Wall Street Journal* reports that the musician's union is still pondering the situation.)

One of the nicest features of the Synclavier, and one which microcomputer people could learn from, is that it is almost totally user-transparent. It looks and feels like a musical instrument, rather than a computer. Data entry is made by an analog-styled pot, rather than through a keypad. Instead of confronting the musician with an overwhelming array of controls, legends light up to indicate the function of a single large knob.

In all, it is one of the few powerful digital devices (other than bank automatic teller machines) that doesn't scare off computer-phobic users.

Doing It with an '80

Microcomputers like the TRS-80 are not fast enough to generate high-quality sound or video, but a lot of real-time studio applications use micros with hardware add-ons for additional functions.

Spectrum analysis is a helpful technique in audio recording. It is a measure of the acoustic energy existing in each frequency range: the volume for the low notes versus the middle or high ones. Engineers use spectrum analysis to verify their recorders' accuracy. Producers use it to tailor sound to an environment (a good mix for a discotheque is not going to be very good on a car radio). Until recently, spectrum analyzers were hard-wired LED displays that either cost a lot of money or did not provide subtle enough readings.

Eventide Clockworks, a New York manufacturer of a popular time-compressor and other studio equipment, has also come out with a TRS-80-based solution to spectrum analysis. Their relatively inexpensive hardware plugs into a 16K Level II machine, and cassette software turns it into a fast and accurate real-time analyzer. The overall system is a lot bigger and harder to work

with than dedicated analyzers, but if you already own the computer it can save a lot of money. (The system is also available for the Pet.)

Eventide's Richard Factor is behind a slow but growing trend to get micros into the studio. Many of his products have a port for digital control, and he has written technical articles on studio/computer bus structures. While some equipment (including Eventide's) uses the IEE-488 bus, which is also used by Hewlett-Packard and Pet, others (SMPTE controllers among them) have the same RS-232 as the TRS-80 and most minicomputers. Eventually a standard will have to be adopted.

Information Processing Applications

Most audio and video studios using the TRS-80, batch-process data using software written in Basic and a number of disk drives. Frequently, this software is written by the owner or manager of the company: someone technical enough to write complex programs, but who knows the needs of their specific productions. Almost all of the applications are in the areas of data base manipulation, scheduling, and bidding.

A Television Production Company

Viz-Wiz has a reputation for highly creative commercial production in the Boston area. They operate a television studio and computerized control rooms; their production clients include Digital Equipment Corporation, McDonald's and Honeywell.

The kind of people who manage a company frequently determine how a computer will be used. Viz-Wiz is owned by Peter Fasciano (a producer/editor), and Tom Sprague (a video engineer). Since both are technically oriented (rather than financial or sales), Viz-Wiz was able to start using computers and custom software long before other companies of their size.

Fasciano put it this way: "We got into computers when the Level I, 4K machine first came out. My partner and I figured it was time to become computer literate. So we plunked down some money for a one-size-fits-all, disposable computer, the TRS-80. After two months we decided to upgrade and write our own programs. We are still using the same machine, but now it has three disk drives, 48K RAM, and every hardware modification we could find."

The computer at Viz-Wiz is on all day, running a massive production management program that took two and a half years to write. Normally when an advertising agency wants a commercial, they have production

*"If you estimate too high
you can lose the job;
too low, you lose your shirt."*

companies analyze a storyboard (a "comic-book" version of the commercial), ask questions, and prepare bids on a standardized 260-line form that includes estimates for everything from talent and make-up to lunch for the crew. If the client likes the bid, the commercial is usually produced. Since the bidding is competitive, however, most of the bids become merely an exercise for the production company.

Fasciano used to spend most of his time preparing bids: making creative judgments on what was needed to achieve a particular effect, how much it would cost, and how much should be set aside for contingencies. It is a painstaking job; if you estimate too high, you can lose the job—too low, you lose your shirt.

Viz-Wiz's TRS-80 now lets the advertising agency describe the commercial over the phone, asks a few specific questions, and then prepares the complete 260-line bid. The program carries data on freelance crew members and their rates, it schedules people and equipment, and even includes a constantly-updated data base of which agencies are easier to work with so it can make adjustments to the bid.

The program also prepares videotape labels, production logs, an invoice, and a complete date file for an AVR program. According to Fasciano, it is "designed to let a secretary sit down and play executive producer." It also gives the real producer more time to be creative.

Even though their TRS-80 is "...spookily reliable. We have had only two disk I/O failures in a year," Fasciano reports that he is finally outgrowing his Model I and will probably buy a Model II soon to run his entire business operation.

There are other computers at Viz-Wiz, but they are specialized signal-handling devices. One of them, a Quantel Digital Effects Generator, is made up mostly of DEC LSI-11 equipment. It includes five separate CPUs in the main rack and a four-bit micro in the control box. Their editing controller is based around an MC-6800 chip with 16 separate PROMs of instructions. Putting it in perspective, Fasciano told me, "It is nice having all this powerful hardware, but I probably would have had a harder time affording it without my plastic-boxed 'toy'."

An Audio Production Company

Sound production is less complicated than video. Even though my studio is one of the busiest commercial houses in New England and our client list includes K-Mart, Exxon, and MGM, we don't need a very so-

phisticated business or bidding system.

Jay Rose / Sound operates two multi-track recording studios, a separate editing room, and a high-speed, high-quality duplicating system. We also maintain a library of more than 16,000 music and sound effects, and have to keep track of thousands of commercial masters and release copies.

Unlike most music studios, who sell studio time to groups and base their competitiveness on musical taste and sound, we sell our ability to produce finished tapes. Efficiency and creativity are more important to our clients than gold records. There is more data organization involved, and a lot more time spent keeping track of small pieces of tape.

The management of Jay Rose / Sound is similar to that of Viz-Wiz: It consists of my wife (a writer/producer) and myself (an engineer/editor). Our goals are production oriented, rather than business. Once we acquired a disk drive for my Model I, it seemed natural to use the computer for production data.

The system usually lives in my house where I can batch-process material at night. Since programming in Basic is so easily self-taught, I have been able to write almost all of our software in a menu-driven format that other studio employees can operate. This way, I can bring the computer to work when there are large data-entry or interactive filing jobs.

Most of our programs are straightforward: processing text for labels, keeping track of client commercial numbers, or computing union-mandated talent payments. Two of our programs represent more interesting programming concepts, and

1: JAY ROSE PRIVATE STOCK	21: AFRICA
3: AIRPLANES	4: AIRPORT
5: ALARMS	6: ANIMALS
7: APPLAUSE	8: AUTOMOBILES
9: BARRIERS	10: BASKETBALL
11: BASKETBALL	12: BATTLE SOUNDS
13: BELLS	14: BIRDS
15: BOATS	16: BUSES
17: CANNON	18: CARS
19: CATS	20: CHILDMEN
21: CHRISTMAS	22: CITY SOUNDS
23: CLOCKS	24: COMEDY
25: COMMUNICATION	26: COMPUTERS
27: COOKING	28: COGS
29: CRASHES	30: CREAKS

NOT -ENTER- TO TURN PAGE.

Some of the available cross-references in the sound effects sorting program.



**If you have
anything to do
with the TRS-80*
System you
should be
reading the
*EIGHTY
SYSTEM
NEWSLETTER*
every week!**

Don't miss a single issue of the new Eighty System Newsletter... published weekly and mailed every Friday by First Class Mail. This is the only publication designed for personnel in the TRS-80* industry, including manufacturers, distributors, dealers and computer users. The Eighty System Newsletter is compiled and edited by Ken Gordon, producer of the National TRS-80* Show, the Eighty/Apple Show, the NJ Microcomputer Show, and publisher of the Amateur Radio Equipment Directory. Here is valuable information in professionally prepared format about TRS-80* hardware, software, peripherals, trends in the industry, and latest news. In addition, each weekly issue contains brief digests of articles related to the TRS-80* system appearing in over 100 computer related and general interest publications. This bibliography will save you both time and money in keeping up with articles in print on the TRS-80* computer system. The Eighty System Newsletter is a must for all active TRS-80* users, plus anyone involved in any way with the manufacturing, distributing or retailing of TRS-80* products.

Subscribe today: Mail the coupon with your check for \$39 for the next 52 weekly issues (sent First Class Mail that's only 75¢ per week.) If for any reason you are not satisfied with the Eighty System Newsletter — we will refund the undelivered portion of your subscription.

KENGORE CORPORATION

3001 Route 27
Franklin Park, NJ 08823
(201) 297-2526

Enclosed is my check for \$39 for the next 52 issues of The Eighty System Newsletter (sent First Class Mail).

Name _____
Company _____
Address _____
City _____ State _____ Zip _____

*TRS-80 is a Registered Trademark of Tandy Corporation/Radio Shack Division.

“... watch the console controls moving up and down without human intervention while a piece of music ‘mixes’ itself.”

may provide some hints for other users who write their own software.

Our mailing list doesn't work on most mail-list programs. While we might have no more than a few hundred separate company names and addresses, each company might have as many as ten different employees we need to communicate with. We devised a double-list mailing system. One list keeps company information (including client details and tax status) in a random-access file. Company account numbers are replaced by a three-letter mnemonic (Needham, Harper & Steers becomes NHS, Ingalls Associates is ING) chosen by the operator. The first few sectors of the file carry the mnemonics and direct the computer to the right logical record for that client. The other list is made up of individual names, job function codes, and their company mnemonics. Ten people in a company still require only one entry of the company name; yet a company with only one or two names doesn't waste disk space. If a person changes employers, it just requires editing the three-letter code.

Our other unusual program sorts and cross-indexes sound effects. The way sounds are interpreted changes with the context: A recording of a sail flapping, with creaking wood and seagulls, is a boat. But

the same recording, with other backgrounds, can be a flag flying or someone making a bed. Filing a sound by its title and nothing else closes off a lot of creative possibilities.

Our sound effects program files effects by title, publisher, tape number and selection, and length. It also adds three additional codes for cross-references, in any of 200 categories. The entire data base is alphabetized four ways and printed into a 60-page book, which we can update any time we want to. Since the data is only entered once and then stored in compressed form, the program is very efficient. It also checks each entry for reasonableness and queries the operator for out-of-range conditions.

We also use Lazy Writer with a number of Basic utilities for automatic line numbering, alphabetization of files, and two-column printing. Of course, we also have SMPTE and time-compression equipment.

Other Studio Applications

There are dedicated computer uses that do not apply to my operation. Console automation, for example, becomes almost a necessity when 46 tracks of rock music are being mixed. Nobody can control a few hundred faders, equalizers, mutes and other functions and still remember a pro-

ducer's creative instructions. Perhaps the most interesting automation system is NECAM, made by the Neve Corporation. NECAM uses the same SMPTE code as audio and video productions, but each time a control on the console is moved it writes the time and nature of the move to disk. During playback, servomotors duplicate the engineer's hand motions. Producers can sit and watch the console controls moving up and down without human intervention, while a piece of music "mixes" itself.

One prototype computer system for the recording studio doesn't use tape recorders at all. Telefunken is introducing high-quality digital recording entirely on hard disk, with editing and mixing instructions carried in RAM. The recording is not subject to any of the usual distortions of an analog tape system, so the sound quality is excellent. Unlike conventional digital recorders, the entire piece of music is available to the computer at once. It becomes very easy to combine a few bars of the drum track from the front of a song under the vocalist from the end, or keep on repeating a bass figure while all the other instruments go on with their original recording.

What's in Store

An important thing to remember with any of these dedicated minicomputer applications, from video manipulation to music synthesis, is how quickly computers have grown more powerful. Many of the things minicomputers are now doing could not have been done on the largest mainframes ten years ago. It is entirely reasonable to expect them to be done on general-purpose microcomputers within the decade.

The back pages of this magazine already feature sophisticated data acquisition modules for the TRS-80, and recent articles have covered speech synthesis and other real-time applications.

There are physical limits to how much high-quality sound or video can be manipulated in a given memory. Audio requires a sampling frequency on the order of 40,000 times a second and video is many times higher; at those rates you could just about store the words "TRS-80" in your machine. But memory is getting smaller and cheaper while CPU chips are getting bigger and faster.

In a few years you may be able to synthesize your cosmic vision of the world, in sound and color and full resolution, on your home television... using your pocket computer. ■



An editing computer in the author's studio. The three sets of numbers (two on the keyboard, one on the screen) are SMPTE code locations. The LED graphic display above the screen is a spectrum analyzer.

THE SWITCH

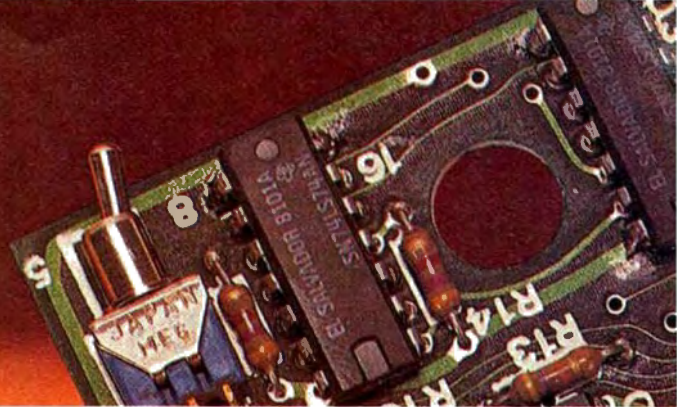

SWITCH TO 5⁷/₈" DOUBLE DENSITY

LNDoubler 5/8

FEATURES

- 5- and 8-inch* disk drives
- Single- & double-density
- Any size and density in any mix
- Read Model I, II* and III disks
- 5- or 8-inch* system disk
- Single & double sided disk drives
- DOS+ 3.3.9 included, with Disk BASIC.
- 6 month warranty
- Up to 3.75 megabytes online
- Easy installation – plug-in & run
- Analog phase lock loop data separation
- Precision write precompensation
- Regulated power supply
- Guaranteed operation at 4MHz
- All contacts gold plated
- Solder masked & silk screened
- Runs under DOS+ 3.3.9, TRSDOS 2.3, NEWDOS 2.1, NEWDOS/80 1.0, LDOS, NEWDOS/80 2.0, and ULTRADOS
- Reads 40- and 35-track disks on 80-track drives
- FD1791 controller + your FD1771
- Fits Model I expansion interfaces
- Fits LNW expansion interfaces
- Track configurations to 80-tracks
- 5 inch disk storage increased to:
 - 161,280 bytes – 35-track SS/DD
 - 322,560 bytes – 35-track DS/DD
 - 184,320 bytes – 40-track SS/DD
 - 368,640 bytes – 40-track DS/DD
 - 368,640 bytes – 80-track SS/DD
 - 737,280 bytes – 80-track DS/DD
- 8 inch disk storage increased to:

591,360 bytes – 77-track SS/DD
1,182,720 bytes – 77-track DS/DD
SS: single-sided DS: double-sided
SD: single-density DD: double-density

COMPLETE – The LNDoubler 5/8, switches your Model I or LNW-80 into the most versatile computer you can own. The LNDoubler's switch allows you to boot from 5- or 8-inch system disks, and it's accessible from outside the interface. The LNDoubler 5/8 comes with a double-density disk operating system (DOS+ 3.3.9), complete with BASIC and utility programs . . . ready to run your software NOW!

VERSATILE – Whether you want single-sided, double-sided, single- or double-density, 5- or 8-inch operation, complete versatility is here today! Any combination of 5- and 8-inch disk storage is possible with the LNDoubler 5/8. Each of your present 40-track, single-sided 5-inch drives will store up to 184,320 bytes (formatted storage) – that's an 80% increase in storage capacity for only half the cost of just one disk drive. With three 8-inch double-density, double-sided drives your Model I will have 3.75 Megabytes of online storage – that's more storage than a Model II or Model III!

ADVANCED – The LNDoubler 5/8 is the most technically advanced, tested and reliable double-density

board you can buy. The LNDoubler 5/8 has more features, more options and more software support than any other product of its kind.

EASY TO INSTALL – The LNDoubler 5/8 is easy to install. There are no traces to cut, no wiring to do, just a screwdriver and a few minutes of your time is all that is required. The instructions are fully illustrated for all interfaces. In minutes you will be 'up-and-running', and enjoying your computer as never before.

COMPARE – Compare features, compare quality, compare value, and make the SWITCH today!

Immediate delivery from stock – at your dealer NOW for only

\$ 219.95

DEALERS – You too can make The Switch.

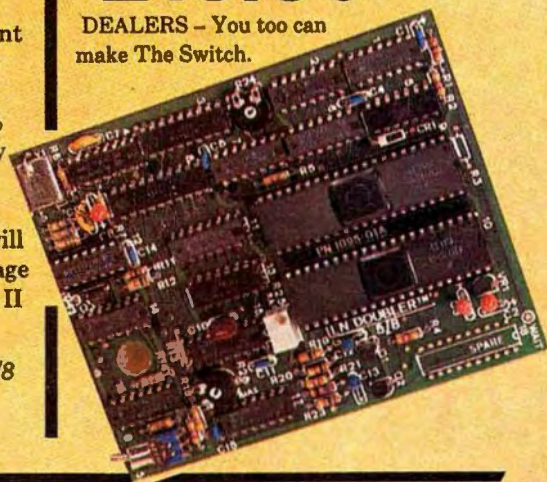

LNW RESEARCH CORPORATION

2620 WALNUT Tustin, CA. 92680 (714) 544-5744 (714) 641-8850

*8" drive operation requires special cable, 8" double-density requires 3.55MHz CPU speed-up modification or LNW-80 4MHz computer. TRS-80 is a trademark of Tandy Corporation.



Hop on board the spirograph special with Commander at the throttle.



Spiromania

by Jake Commander
80 Microcomputing staff

What do you get when you cross a constantly changing angle with a constantly changing radius? Don't all shout at once. What you get is a spirograph, and you already knew that, right? If so, go to the top of the class and the end of the article. If you didn't know that and you share my fascination for those immortal coils, read on.

Early Art

As soon as I ever saw a table-top spirograph set, I just had to have one. Those plastic cogs, colored pens and amazing

patterns intrigued me. I even went to the extra effort of buying one of those multi-colored ballpoint pens with about 20 different color inserts, ranging from a kind of puerile pink to pulmonary purple—perfect for spirographs! I specialized in creations using different shades of the same color and never ceased to be amazed at the possible variations. The way the patterns interacted, causing moire effects to elicit shapes within shapes, was and still is just about my favorite spirographic effect.

On a video screen, the interplay between pixels can be even more stunning than ink on ink. It seems only natural, after getting my Color Computer, that I was drawn into creating computerized psychedelia.

In the March 1982 issue ("The Editor's Choice," page 78), *80 Micro* published one of my programs for creating some spirographic effects, but the program was written in Basic and suffered from the usual drawback of Basic programs—lack of speed. The version in this article is a much more streamlined version and allows many more options. To use the program described here, you need Extended Color Basic with a minimum of 16K RAM. The machine code can be entered using one of the many monitors available for the Color Computer or it can be assembled using a 6809 assembler. My version of the assembly source code was created using the software development system SDS-80C from

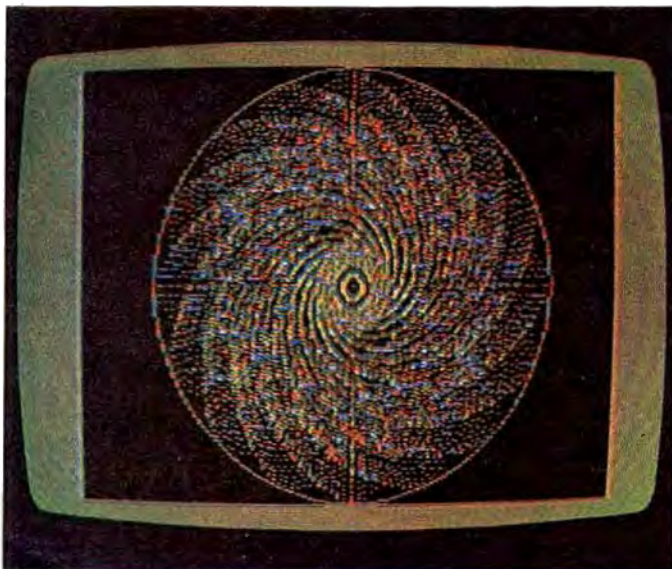

Photo 1

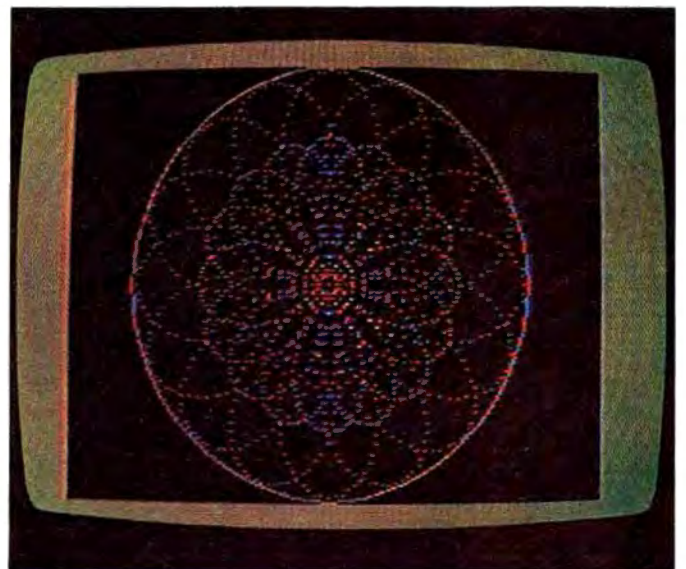

Photo 2

**MISSION: TO DEFEND...
AND SURVIVE!**



by Jeff Zinn

Now Available: the Futuristic

TRISSTICK

Model 1 AND Model 3 owners may now purchase the new, exciting, and versatile "TRISSTICK". The TRISSTICK is compatible with all of our games and comes packaged with complete instructions for use with your own programs. It features the famous Atari joystick with a molded plastic interface module that simply "plugs in" to your computer: no modification or wiring is required.



BIG FIVE SOFTWARE

P.O. Box 9078-185 • Van Nuys, CA 91409 • (213) 782-6861

Prices per game: TRS-80 16K Lev2 Mod1/Mod3 Cassette — \$15.95
TRS-80 32K Lev2 Mod1/Mod3 Diskette — \$19.95
Joystick (specify Mod1 or Mod3) — \$39.95

10% discount for 2 items ordered, 15% for 3 or more.
Please add \$1.75 per order for shipping, foreign orders add \$6.00.
California residents please add 6% sales tax.

All products ©1982 by Big Five Software.
Programs are all 100% machine language for high quality graphics. Disk version saves high scores to disk & is compatible with TRSDOS. Sound effects are playable through the cassette AUX plug. Please call or write for information on all of our products. TRS-80 & TRSDOS are trademarks of Tandy Corp.

“By slightly altering the way in which each spirograph is drawn at every pass through a program loop artwork can be created that is amazing in its creation and execution.”

the Micro Works—an excellent ROM-based package for machine code programmers of the 6809 persuasion and worthy of special mention.

Present Genius

This program allows you to fabricate patterns by drawing multiple spirographs one on top of the other. By slightly altering the way each spirograph is drawn at every pass through a program loop, artwork can be created that is amazing in its creation and execution. The interplay between one layer and another can cause unpredicted new

designs to evolve. Some aesthetic judgement is required; it's all too easy to go over the top and create a graceless hideosity resembling an undercooked pizza.

As the photographs show, with a little experimentation it's possible to create anything from ornate arabesques to stained-glass replicas. The results can be truly dazzling; so much so that when I was working on this project I endured what might be termed sensory overload. The vast richness of color and shape would periodically dull my senses to the point that I couldn't differentiate between pretty nice and pretty ugly. Enough proselytizing; the results, dear readers, I place at your feet.

Uh-Oh Math

To attain quality truly deserving of space in an art gallery, we should have some understanding of what we're doing. I can almost hear you murmuring, "Here we go again. Here comes the nitty-gritty—more math. Bye-bye article." Well, hold on, I'll make it as understandable as possible. A small amount of trigonometry is all we need, and you may know it already. I make no apology for any over-simplifications; math buffs go to the back of the class and chew on some glue for a while.

The main thing we need to understand is the sine function. We also need the cosine function, but it's so closely related to the sine that if you understand one, you understand both.

A diagram of the sine function is shown

in Fig. 1. You've possibly seen graphs like this before and avoided them like the plague: all will now be revealed. Take a look at Fig. 2; it is the cosine function.

Second Things First

Notice how similar Fig. 2 is to the sine graph. I've purposely shown it for 90 degrees before the zero point to emphasize its similarity. If it looks to you like the sine shape pushed sideways 90 degrees, then you have it. That's exactly what it is: The cosine of an angle is the sine of the same angle if 90 degrees were added to it. So if you want the cosine of a particular angle, add 90 degrees and take the sine—that gives the cosine of that angle.

That's dealt cosines a blow; now you can see how you understand one if you understand the other. But we haven't looked at sines yet, so stick with it.

In the present context, when we talk about sines we're talking about circles or circular motion. Since circles are all around us, from the coins in our pockets to the motion of our planet around the sun or the rotary motion of machinery, it's no wonder the sine function crops up so often. In our case, we need it to tell us where to plot dots (or pixels) on the video screen in order to produce motifs and designs based on the humble circle.

Let's pick a circular object, like a clock, to help us analyze what the sine function can tell us. To simplify matters, this clock has only a minute hand. To reinforce the mental

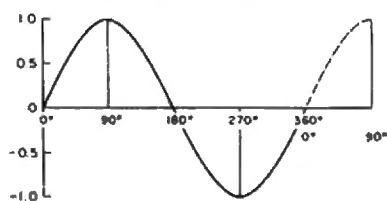

Fig. 1. The Sine Function

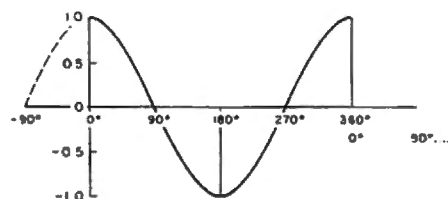

Fig. 2. The Cosine Function

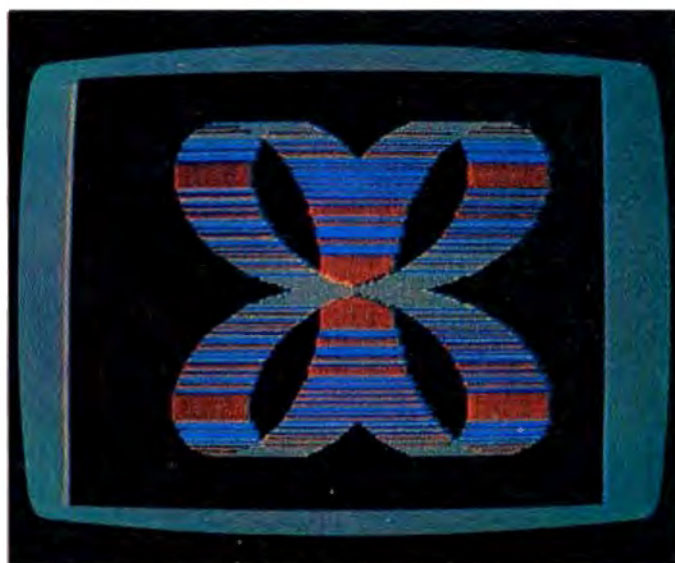

Photo 3

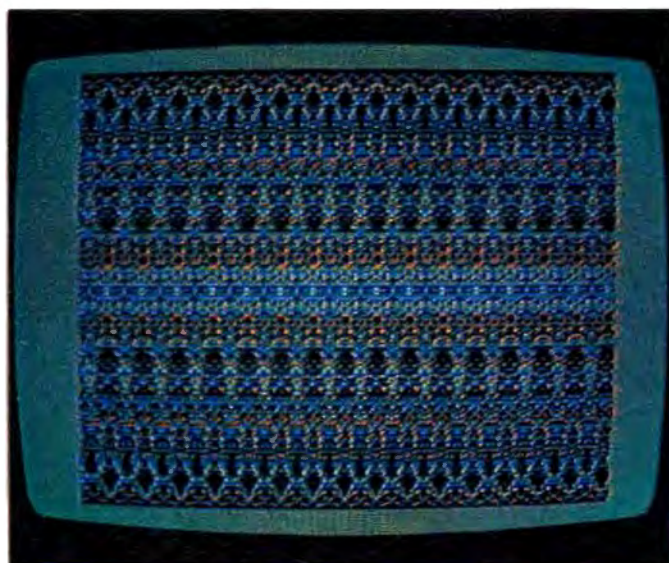

Photo 4

FUTUREVIEW

GREAT NEW PROGRAMS FOR YOUR TRS-80!!!

All programs work on both Mod I and Mod III systems

NON-DISK™ BUSINESS SOFTWARE

What is NON-DISK software? If you own a small business, you may not require a \$5,000 computer system. But a small computer would be a big help. With the aid of our packages, your present Mod I or Mod III computer and a small printer you can have business computer power without the unnecessary extra expense of disk drives. Our NON-DISK software keeps cassette access to a minimum by performing extensive memory crunching. All information is kept inside the computer while in use, then stored to cassette when you are through for the day. All programs are VERY fast, and feature the unique MACH-5™ sort routine. Up to now, expensive disk drives have been required for efficient business operation. NON-DISK is here to change that!

NON-DISK SALES INVENTORY™ allows you to use your computer as an automatic ticket-writer and inventory system. When you write up a sales ticket, the computer figures subtotals, taxes, totals, and at the same time subtracts sale quantities from inventory. It keeps track of daily and weekly sales, sales tax, charge totals, sales totals for up to ten people at one time, and total cost and retail values. After all this work is done, it hands you a neat, impressive sales ticket (with duplicates). Inventory information includes stock number, name, quantity, cost, and a retail price. A full list of inventory is available at any time.

Make your job easier and more accurate. 16K - 205 items; 32K - 635 items; 48K - 1065 items \$49.95

NON-DISK SPEED WRITER™ is the low cost typing package that is FULLY INTERACTIVE with our ADDRESSER package. The SPEED WRITER allows the following capabilities: 1-Type as fast as you like. SPEED WRITER will keep up. 2-Choose any line length up to 120 characters. 3-Store information for use or alteration at a later date. 4-Upper case AND lower case characters are standard (even on Mod II). 5-Automatic center and half-line tab. 6-Print out multiple copies using your printer's special print modes. 7-Editing, line insertion, and line deletion without correction fluid. 8-Easy to understand instructions. You can be operating this system within 15-30 minutes... no 8-hour lessons! 9-Generate addresses using the NON-DISK ADDRESSER and have addresses automatically print on your letters. SPEED WRITER can be used for letters, reports, documents, virtually anything you can use a typewriter for.

SPEED WRITER doesn't offer the extensive functions you'll find in larger word-processing packages, but it doesn't have a \$100 price tag either! It makes an excellent normal typing generator, a useful addition to your business. 16K, 32K \$24.95

NON-DISK ADDRESSER™ allows you to enter names and addresses into your computer and print them on either mailing labels OR envelopes (along with your return address)! You may sort by either name or zip code and store your list for later additions, or for use by SPEED WRITER. End the drudgery of hand addressing. 16K - 100 addresses. 32K - 250 addresses. 48K - 400 addresses. \$24.95

TO ORDER: Send check or Money Order. **WE PAY POSTAGE!** We will answer non-order inquiries if they include a stamped, self-addressed #10 envelope (BASE). All orders are shipped within 5 days. Phone lines are open 10 a.m. - 3 p.m. (all time zones) Mon - Fri. Games are available on Mod III disk (add \$5.00 to price. Requires 2 disk system.)

DEALERS: Send business card and an BASE for complete dealer information

NON-DISK

ELECTRIC BOOKKEEPER™ At last, General Ledger for your cassette-based system! Keep records for up to 50 accounts including CASH, SALES, EXPENSES, A/P, A/R... all definable by YOU. Transaction information includes Date, Debit account, Credit account, Amount, and Reason for transaction. The ELECTRIC BOOKKEEPER allows full editing and print-out functions, including Transaction Listing, Balance of Individual Accounts, Trial Balance Sheet, Trial Income Statement, and End-of-Period Processing. Above all, the system is easy to understand and use. 16K - 230, 32K - 740, 48K - 1250 transactions per period \$49.95

NON-DISK CHECK SYSTEM™ A truly excellent check register and checkbook balancer. Its error checking functions can show you an error even if your checkbook seems to balance. CHECK SYSTEM will perform all math for you, balance your book, reconcile your statement, and keep a permanent record on cassette tape. CHECK SYSTEM supports two modes of operation for business or personal use. Don't spend frustrating hours trying to balance your checking account. NON-DISK CHECK SYSTEM will easily keep track of all your records! Supports but does not require a printer. 16K - 260 entries, 32K - 725 entries, 48K - 1190 entries .. \$24.95



COMPUTER TYPING COURSE™ Teachers and parents especially will want this package. If you've ever wished you could touch-type, this package is just what you need. You can learn to type at your own pace, getting to know finger positions, the keyboard, special characters, numbers, shift, and enter keys. CTC consists of several lessons, each taking a certain part of the keyboard and covering it thoroughly before continuing on to the next lesson. You may review any lesson as many times as you like. As an added bonus, CTC offers accuracy tests at the end of each lesson, and a "Practice Page" that allows you to type anything you wish in order to build your speed. We feel this is the best on the market. 16K \$19.95

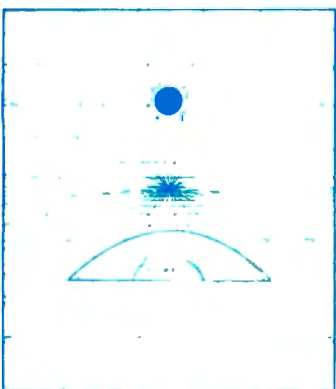

THE PHASE VII™ GAME SYSTEM

In 1978 the first easy-to-play role-playing game appeared on the market... PHASE VII. It was very popular because of its unique feature of using the realms of fantasy AND science fiction. In 1980 it was introduced as a computer game in 16K and 32K versions. The general response was, "It's pretty good, but it could be better." The programmer was crushed and holed himself up in a 3 x 5 closet. He has been working on the program now for two more years. Introducing:

COMPUTER PHASE VII 3.0

The new version is Incredible! Imagine yourself aboard a huge space station where both magic and science work! Armed with your special powers you will fight terrible creatures (watch out for the deadly killer toadstools), while searching for the elusive treasures. As you play, you become more powerful and experienced. The game NEVER ends; one sequence of play leads into the next. No two games are the same. You can take on any identity you wish, and have but one single goal: TO SURVIVE. Includes illustrated rule book \$24.95
Original PHASE VII (if purchased with COMPUTER PHASE VII) \$7.95
(if purchased separately) \$8.95
FOR MASOCHISTS ONLY (solitaire module allows you to play PHASE VII by yourself) \$3.95

P7 FANZINE

One year (mailed first class) \$10.00

CHESS BOARD™

There are plenty of programs around that allow you to play chess with your computer. But what about when you want to play chess with your friend (and show off your computer at the same time)? CHESS BOARD allows you to use the computer as an automatic board. It uses a unique mono color field for easy recognition of pieces, and supports En Passant, Castling, and Pawn Advance. Now you can boast the most expensive chess in the neighborhood. Use your computer! 16K \$14.95

WORMHOLE™

Our favorite! A truly great arcade game. You are the navigator aboard the Seeker, a vast deep space cruiser with hyper drive engines. Unfortunately, these engines are malfunctioning. You have just entered a "wormhole," a dangerous warp in the fabric of space. The sides of the wormhole are supercharged, and mean instant destruction if you touch them. Asteroids are also caught in the wormhole, and you must avoid them as well as the hole. To make things really peachy, the wormhole itself is shifting, causing you to warp back and forth between several different universes, all of which contain a different hazard. As a final blow, your fuel is getting low and you need to find a fueling station! A really enjoyable game 16K \$19.95

PROGRAMMERS: Your software is valuable, and we're the best choice for marketing! Send us an BASE and we'll tell you why. Or better yet, send us a copy of your program for analysis. We market your program FAST! There is no need to wait for a year or more for a marketing decision. FUTUREVIEW will make you money, NOW!

FUTUREVIEW P O BOX 101 JOPLIN, MO 64802 (417) 781-5995

NUCLEAR BEEHIVE™

"The reactor's gone critical! Run for cover!!!" The 'Beehive,' the world's most powerful and dangerous super-reactor, has been sabotaged! The scientist in charge has been killed, leaving you to figure out the call sequence required to damp down the reactor before it starts core meltdown. If you make a mistake, you will not live to regret it. The Beehive is humming. Time is running out. With sweat pouring down your face, you begin. 16K \$14.95



DRAGONLAIR™

Ages ago a great king lived in a series of caves. His daughter fell into a deep sleep (actually, she hacked off a wizard and he put her in suspended animation. Served her right). The king died of grief (not to mention doctor bills), and out of loyalty his servants still remain. Also remaining is a somewhat incredible treasure.

Oh, one little thing. Before he died, the king placed a small dragon to watch over his treasure. That was 500 years ago. Now there is a large dragon. DRAGONLAIR is not an adventure game. There are over 100 rooms with no dangers. Well, almost none. There is one little surprise... 16K \$14.95

LASER LIGHTS™

Put on your favorite record or tape, dim the lights, lean back in your favorite chair, and turn on your computer for one of the most interesting display programs you'll ever see. LASER LIGHTS is a unique, impressive computer light organ. Your favorite music suddenly becomes a pulsating, almost hypnotic computer display. The patterns you see are not random or preset. They are generated completely by your music. Enjoy multiple speed and rhythm sensitivity. You are now within our power. 16K \$12.95



MAROOED AGAIN™

Are you sick of adventure games that go beyond all logic? Relief at last! This one is the best we've ever seen. You have crashed your ship on a hostile planet (fifth time this week). But all is not lost... you've found an alien ship! The crew is dead, but the ship is in perfect condition. You simply need to find the components to get it to blast off. You send an android to scout the ship, but it was damaged in the crash and it's liable to do almost anything. You must get the ship started and blast to safety. In MAROOED AGAIN all events are logical... and dangerous. 16K \$14.95

MODEL I/III

SUPER SKETCHER MODEL I/III

Have you ever wanted to add graphics to BASIC programs as BASIC subroutines in minutes rather than hours or draw schematics, charts, graphs, maps, cartoons or logos such as logos using graphics & alphanumerics, save graphics as pages and animate them or print them with your EPSON MX 80? SUPER SKETCHER is the answer. It works like a text editor with graphics. It's easy to use and features:

- Full Cursor Control
- Help Table
- on-screen editing
- Circle, Square, Sine Wave & point to point commands
- Edit & animate 10 Graphics screens at one time
- Save Graphics files, BASIC subroutines & programs on disk or tape
- 128x45 or 64x15 display
- Built in Epson MX-80 driver
- and much more.

SUPER SKETCHER Mod I/III DISK \$29.95

CODES II for the ELECTRIC PENCIL

CODES II for the Model I and the ELECTRIC PENCIL is an easy to use software package that lets you enter printer control codes into your PENCIL text files with NO hardware additions. Shift your printer into Double Wide Condensed, Expanded character fonts and send any special control codes to your smart printer to get it to do what you bought it for. CODES II loads into the Electric Pencil and includes codes for Epson MX 80 & 100, R/S, II, IV, VII & VIII, Centronics 737/739, MPI 88 series, Okidata Microlines and one that you can customize.

TAPE \$19.95 (Requires lower case) DISK \$24.95

DISK INVENTORY SYSTEM MODEL III

DISK INVENTORY for the Model III allows you to keep track of your disks permanently! This Menu Driven indexed utility lets you search through up to 99 disks (4.75z diskless) in 1 second and display or print them alphabetically by name, extension or disk number. Printer driver has built in page numbers & spacing in all modes and a unique disk bar code labeling feature.

MODEL III DISK \$29.95

AUTOMATIC MENU SYSTEM MOD III

AUTOMENU for the Model III is more than just an automatic menu system. Just power up and AUTOMENU takes over with a complete menu to Execute, Load or List Programs & Command files or enter Debug, Basic or System with a single keystroke. Ideally suited for office use.

MODEL III DISK \$15.95

16K RAM \$15.99

Premium 16K 200 Ns RAM for TRS 80 Model III-1 computers. Includes ram test & instructions. **ONE YEAR GUARANTEE** (Model I owners add \$2 for dip. shunts)

DEALER INQUIRIES INVITED

Allow 2 weeks for personal use. Key C. 1111 orders add \$2.00. When ordering specify computer type and add \$2.00 for S.H.M. Co. retailer's add'l 5% sales tax. VISA, Master Chg.

VISA/MASTER CHG. ACCEPTED



128

**NELSON
SOFTWARE
SYSTEMS**



P.O. Box 19096 - Minneapolis, MN 55419 - 612/827-4703

TRS 80 is registered trademark of Tandy Corp.

"Let's pick a circular object, like a clock, to help us analyze what the sine function can tell us."

image, the clock is two feet high, thus giving the minute hand a length of one foot. The diagrams in Fig. 3 should help you grasp the idea.

First Things Next

Imagine you're standing at the 12 o'clock position looking across the face of the clock. That's important—we're not looking straight at the face, as if we wanted to read the time, we're peering along its surface. In the case of the first clock we'd be staring straight down the minute hand. Now, how much of the length of the minute hand do you see from that 12 o'clock position? The answer from sheer intuition is zero. If we're staring straight at the hand pointing at us, all we'd see is its width; we'd see none of its length. That's the first feel we get for the sine function; the hand has an angle relative to our position of zero degrees and we see the sine of its length which for zero degrees is zero.

Now, wait 15 minutes or if you're less patient, rotate the hand to the three o'clock position. How much of its length do we see now? Once again, intuitively we realize that if it's at an angle of 90 degrees to our position, we'll see its whole length. Another way of saying this is that at 90 degrees we see its length times one, which correlates nicely with the sine of 90 degrees, which is one.

OK, move the hand to the six o'clock position; this time it's pointed away from us at 180 degrees, so we see none of its length. As you've probably guessed, the sine of 180 degrees is zero—the same as the sine of zero degrees, except now you see why. The next step is to the nine o'clock position, at which point you may think you observe the whole length again, but what you're really seeing is the negative value of its length. Remember, we saw the length times one at the three o'clock position; at the nine o'clock or 270 degrees position it's reversed, again correlating with the sine of that angle, which is minus one.

Finally, the hand returns to the top of the clock, at 360 degrees, which is the same as zero degrees and we've literally come full circle and start over.

This clock imagery creates a feeling for the sine values at the four 90-degree points of a circle. Try to imagine the hand of the clock turning slowly from twelve to three; the observed length will at first rapidly increase from zero and then slow down until it reaches its full length at the 90 degree position, after which it shortens again. The rate of increase can be seen in the sine wave graph in Fig. 1. The curve starts off steeply

then flattens out at 90 degrees.

Figure 4 shows this more graphically from the point of view of a sine and cosine. Notice that the sine curve repeats in a mirror-image fashion from 90 to 180 degrees, and then we get the negative mirror-image. In fact, just by using the curve from zero to 90 degrees we have enough information to plot the whole sine curve to 360 degrees. That's the approach I use in the machine code, which I'll describe later on.

Sine of the Times

What use is this to us spirographers? Lots of use: If we take any center point in the video display we can now plot a circle using the techniques we've learned. All we have to do is decide on the radius of the circle and use it as if it were the tip of the minute hand.

Remember that we'll be plotting points at the tip of that imaginary hand—not along the whole hand. The best way to grasp this is with another example: let's choose a radius of 10 pixels and plot a circle by setting dots from zero to 360 degrees. It doesn't matter how many dots we use, but if they're spaced close enough together it will appear as if they're one continuous line.

Start at zero degrees. The sine of zero degrees is zero, so we multiply the length of 10 pixels by zero. The result, zero, simply means that on the left-to-right (or X) axis of the screen, the dot is offset by zero dots from the center. The real center of the screen in Basic's PMODE 4 is the 128th dot, giving us the X coordinate. To get the Y coordinate, take the cosine of zero degrees,

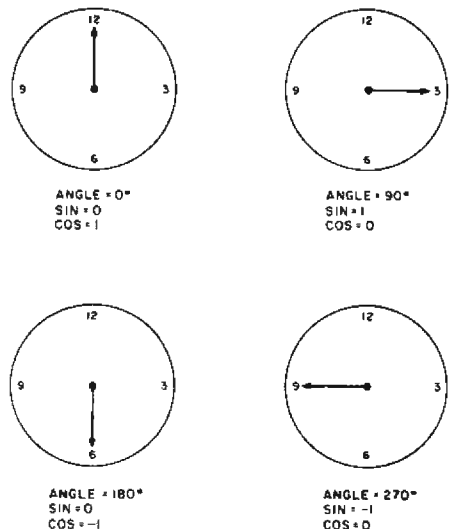
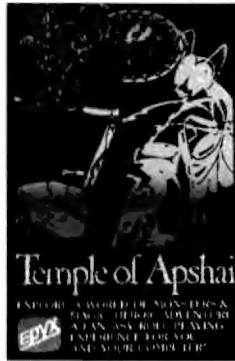

Fig. 3. The Sine Clock

Slaying Monsters Should Be Mostly Fun and Games

An EPYX game from
Automated Simulations



Be one of more than 16 million alter-egos that your computer can generate. Walk into a labyrinth filled with traps, treasures and monsters. There you'll test your strength, constitution, dexterity, intelligence . . . against thousands of monsters in over 200 caverns and chambers—growing in wealth, power and experience as you progress through the four levels of the dungeon.

Your character will do whatever you want him to do. Do battle—in real time—with the likes of giant ants, ghouls, zombies . . . Explore the various levels of the maze and discover the great treasures within.

The Game Manufacturer's Association named The Temple of Apshai the computer game of the year. The Temple is the very first computer game—ever to win the Hobby Industry award for excellence. There can be only one reason for that: it's a great game.

So what will you think of The Temple of Apshai now? Now that it's even better than ever. With better graphics—animated movement—and completely new sound effects that make your computer come alive and make The Temple even more fun.*

The Temple has a superbly illustrated 56-page Book of Lore, and your local dealer has it for the ATARI,** TRS-80,** APPLE,** and IBM** computers.

*If you already have The Temple of Apshai, you can enjoy these great improvements. Just send us your original cassette or disk together with your check for \$5.00 and we'll send you the brand new version—with better-than-ever graphics and sound.

**ATARI, TRS-80, APPLE and IBM are trademarks of Atari, Inc., Tandy Corp., Apple Computer, Inc., and IBM, respectively.

©1981, AUTOMATED SIMULATIONS, INC., P.O. Box 4247, Mountain View, Ca., 94040.

✓28

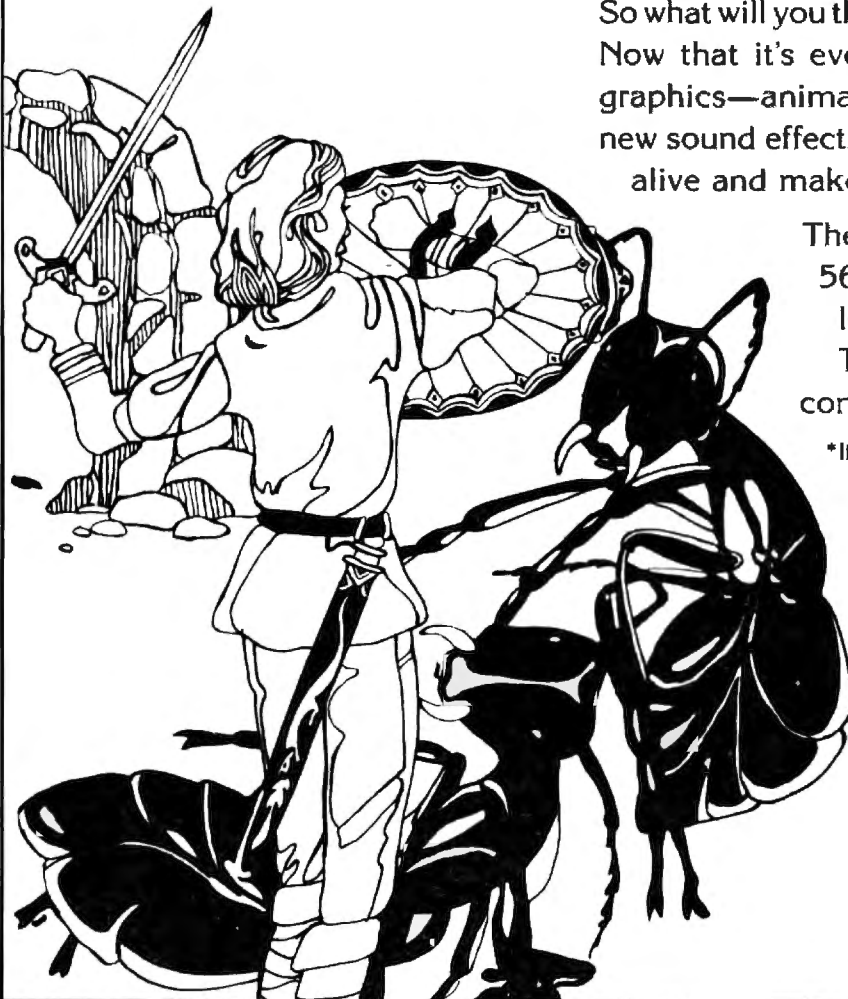

“To appreciate the final technicality of the genus spirographica, imagine what would happen if the radius were changed as the circle was drawn.”

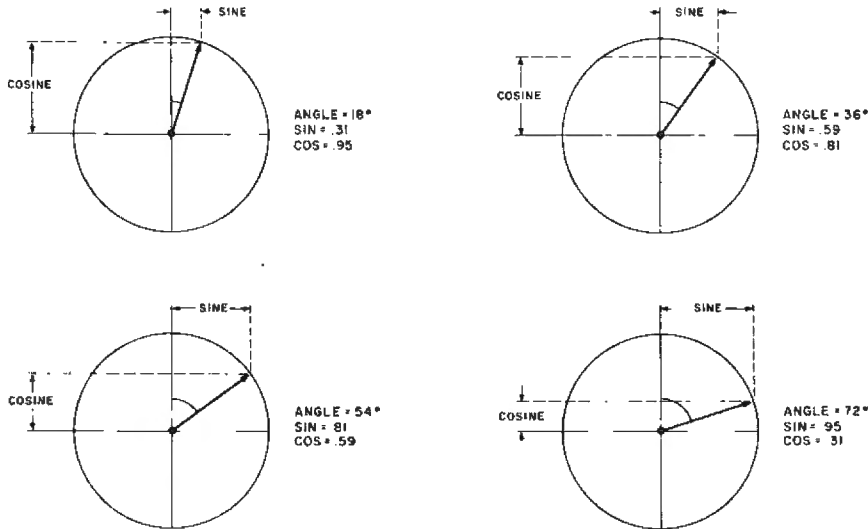

Figure 4

which is one. Multiplying the radius of 10 pixels by one gives us an offset of 10 dots from the center of the top-to-bottom (or Y) axis of the screen. The center position in PMODE 4 is 96, so this would give us a Y coordinate of 106.

This immediately presents a problem; if we plot this 12 o'clock position at 128 dots across and 106 down, we'll be at the 6 o'clock position relative to the center. This is because the Y axis on the Color Computer (and most other graphic computers) is upside down: increasing values on the Y axis bring the plotted points downward instead of up, as in the case of a normal graph. To overcome this minor annoyance, we merely have to negate our cosine results to make the circle come out top side up. So, in our example, instead of adding, we subtract 10 from the center point of 96 which gives us a Y coordinate of 86. At last, we set a pixel at an X,Y coordinate pair of 128,86 and have ourselves a dot at the 12 o'clock position.

Next, we'll step the angle by a chosen, small amount and repeat the procedure, multiplying the 10 pixel radius by the sine and negative cosine values of the new angle, then adding 128 and 96 respectively. This gives us a new dot to the right and slightly below the first dot; we're slowly but surely on our way to drawing a circle. By the time the angle has been stepped to 360 degrees, there will be a circle on the screen with a radius of 10 dots. Notice that if you add different values than 128 and 96, you simply change the center of the final circle.

Now, wasn't that simplicity itself?

Genus Spirographica

To appreciate the final technicality of the genus spirographica, imagine what would happen if the radius were changed as the circle was drawn. All sorts of shapes would present themselves, ranging from spirals to oval shapes to stars to our final goal—the spirograph.

In a real spirograph an inner wheel rotates inside a bigger one. This makes the radius of our circle describe a circular motion of its own within the larger circle. We can approximate this on a computer by multiplying the radius at each plotted angle by the sine of that angle, imparting a simulated circular motion to the radius. Notice that I say simulated; by applying the sine function to the radius, it will take on negative

values—something that's well and good for creating effects, but not what normally happens in real life. In a real spirograph, the inner wheel causes its own radius to gyrate backwards and forwards sine-fashion from a point inside the circumference of the outside wheel rather than the center.

Why bother to write all this complicated stuff in machine code, anyway? It would be easy enough to apply these sine/cosine rules to a changing radius and angle in the good old lingua franca—Basic. The answer is not exactly surprising: speed.

If you tried my program from the March issue, you'll have noticed how slowly the patterns were drawn. Remember, you're plotting a single pixel at a time and for each pixel you need two sines and a cosine. Then, assuming the highest resolution, the coordinates have to be scaled to fit into a 256 by 192 frame on the screen. The Basic interpreter is painfully slow at computing sine functions. That's because these functions work in floating point math which requires many machine code instructions to produce a result which is far too accurate for our needs. Also, the method used to evaluate a sine requires a number of iterations of the Taylor series which converges to approximate the function to an accuracy of five decimal places. It's slow and complicated.

For our needs, a number of zero to 255 is sufficient for the X axis, and zero to 191 for the Y axis. I arrive at these values directly by referring to a table in memory similar to the trigonometry tables you may have used in school. The machine code routine extracts the correct value from the table according to the given angle. In place of the normal trigonometric values from minus one through zero to plus one, I arrive at the numbers from zero through 127 to 255.

To shorten the sine table in memory, I on-

design # (photo #)	Lobes	D/L	X Step	Y Step	Ang Offset	Scale Offset	Comments
1	88	D	0	0	0	40	Pause on 2nd loop
2	88	D	0	0	2	2	Pause 20th loop
3	2	L	2	0	0	0	18 loops
4	5	D	8	0	12	0	To completion
5	88	D	16	0	0	0	4 loops
6	88	D	16	0	0	0	To completion (UR = 4; OC = 87)
7	2	L	0	0	10	10	2 loops (UR = 5; OC = 61)
8	4	L	2	0	0	0	3 loops (UR = 90; OC = 90)

Table 1. Design Parameters

PENETRATOR



Announcing **PENETRATOR** - the fastest and most exciting game ever developed for the TRS80*

PENETRATOR features amazingly fast firing action; accurate bomb release; incredibly smooth graphics and arcade type sound that you have never before seen or heard on a TRS80!

Your mission is to penetrate the enemy defenses, blow up their illegal neutron bomb store and return safely to base - an almost impossible feat!

The console above shows the actual view from your TRS80. The four stages present continually new challenges, and increasing enemy defense means each stage is more difficult than the previous one!

Enemy radar stations constantly track your movements unless you destroy them. You will need all your skill and cunning!

To aid you on your mission, Control Center has provided you with a Training Simulation Chamber; where you may practice your skills in any of the stages before risking your life.

PENETRATOR is a game that will challenge you time after time, hour after hour. The unique customizing feature allows you to change the conditions of the game at will. This means that each **PENETRATOR** package actually contains hundreds of different games to keep you challenged and stimulated.

Don't wait any longer - **PENETRATOR** is available from your favorite software dealer or directly from the publishers.

PENETRATOR includes a 16 page booklet and is compatible with the Alpha joystick.

- Available as:
- 16K TRS Model I/III, two-cassette pack \$24.95
 - 32K TRS Model I/III protected diskette \$24.95
- Please add \$1.50 per order for shipping, foreign orders add \$6.00. California residents please add 6% sales tax. Visa, Mastercharge accepted. Dealer Enquiries Welcomed.

*TRS is a trademark of the Tandy Corporation.

Melbourne House Software 6917 Valjean Avenue, Van Nuys, CA 91406.

“Remember that to arrive at the cosine of an angle you simply add 90 degrees to the given angle and take the sine.”

ly store sine values for the angles zero to 90 degrees. The sines returned for these angles are generated as the byte values 128 to 255 which allow their direct use as X axis coordinates. For use on the Y axis, the value is divided by 3/4 to give the values 96 to 191 as per the screen dimensions. By using the previously mentioned mirror-image property of the sine function, all angles from 90 degrees upwards can be derived from this table to fill in the missing values from zero

to 127 (or 95 in the case of the Y axis). Remember that to arrive at the cosine of an angle you simply add 90 degrees to the given angle and take the sine.

By way of a compliment to the writers of the Circle command in Extended Color Basic, I was horrified to find that their routine drew a circle faster than mine. I was stunned. Where had I gone wrong? In fact, I hadn't gone wrong at all. They cheat by using 64 lines to draw their circle whereas I

plot mine at 720 half-degree increments. Their method is ingenious and very slightly faster, but my circle is rounder—now we're talking artistic perfection! ■

Ed's note: This is the first part of a two-part series, which will conclude in next month's issue. Look at the pretty pictures, study the explanation of sines and cosines, and next month you'll be all set to create great art with Jake's program!

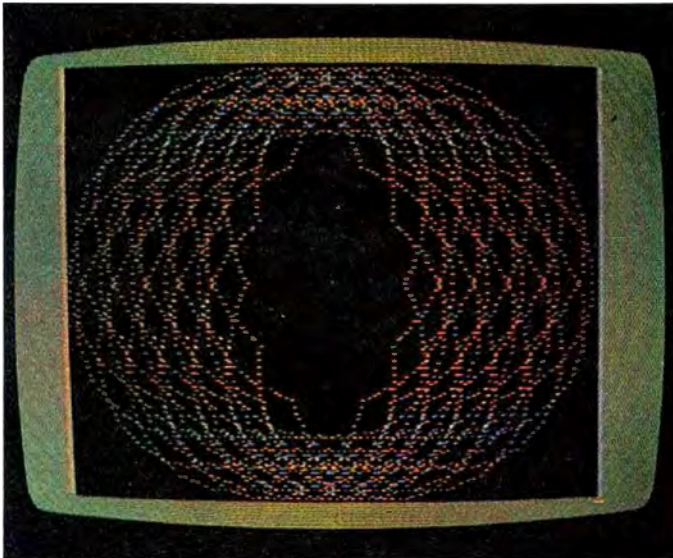

Photo 5

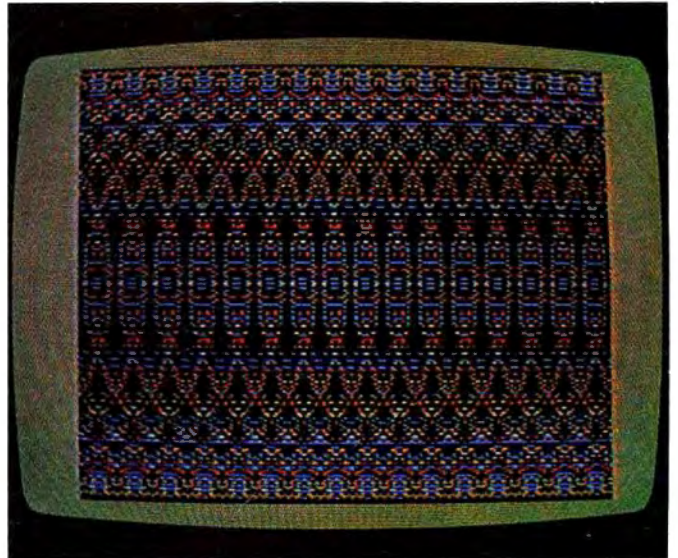

Photo 6

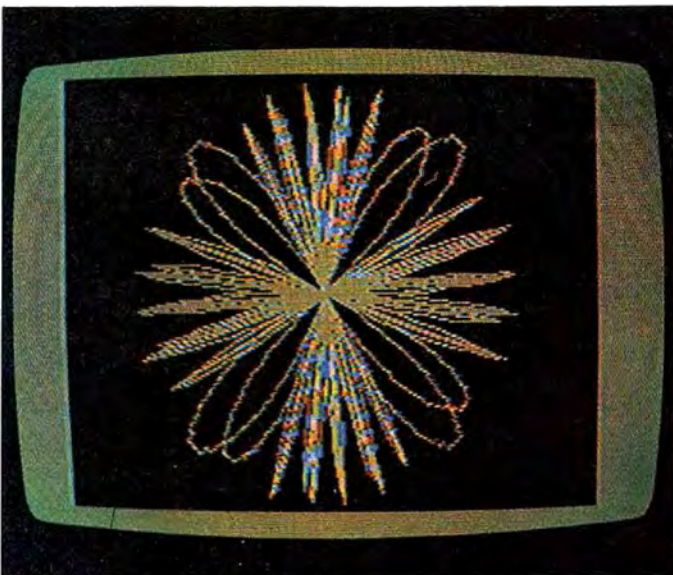

Photo 7

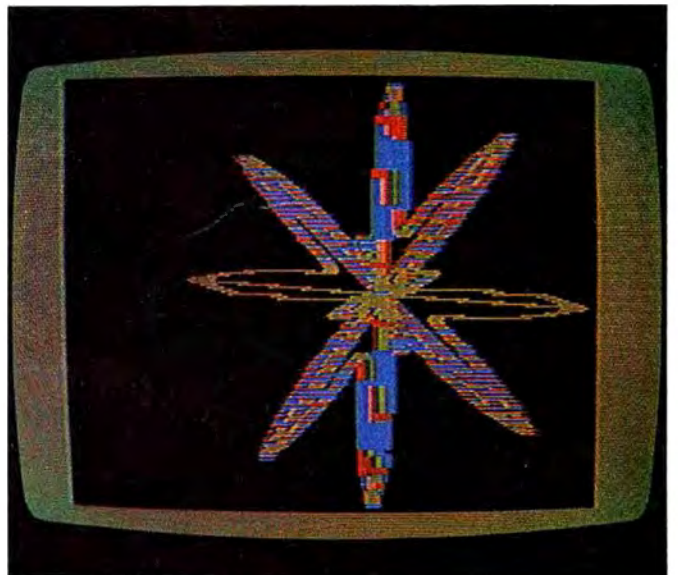

Photo 8

Put Your Fingers On The Pulse Of Wall Street With Your Radio Shack® Computer

If you invest in the market, operate your own business or require updated information quickly to manage your affairs, DOW JONES NEWS/RETRIEVAL® Service provides the authoritative business and financial information you need. . . from Wall Street, Washington and around the world. Now Radio Shack owners can receive this valuable service through TRS-80® Videotex software.

Get Information For Business And Investment Control. . . On Command.

Discover how quickly and easily your personal computer turns into a specialized, sophisticated library of information with access to the Dow Jones data base. It's considered the world's most reliable and comprehensive source of business and financial data providing you with news up-to-the-minute as well as from the previous 90 days.

Now you can review thousands of items from The Wall Street Journal, Barron's and the worldwide Dow Jones News Service without having to maintain piles of newspaper clippings. Information about companies, stocks, labor, government, international market and monetary developments, and so much more, is yours on command.

Quotes From Four Exchanges

Now, in just seconds, you can obtain current prices and the volume traded for stock quotes (15 minutes delayed) on over 6,000 companies. . . plus 50 key financial indicators on 3,200 selected firms and 180 industries. You'll also have access to trading information on mutual funds, treasury notes and bonds.

Imagine being able to spot trends, research a company, obtain data that could affect your business, your investments, your investment decision-making. But you don't have to imagine anything. . . DOW JONES NEWS/RETRIEVAL provides it all right now.

Low Start-Up Cost. . . Free Password.

Stop by your nearest Radio Shack store and find out how easy and inexpensive it is to get Dow Jones investment data through TRS-80 Videotex. Videotex software for Radio Shack computers is only \$29.95. What's more, you get a Dow Jones password absolutely free. . . along with one hour of free introductory time. And there are no start-up or minimum usage charges. In addition, software and usage costs will be tax deductible in many cases (consult your tax advisor for further information).

Customer Support. . . Just A Phone Call Away.

Dow Jones' professional customer service staff is ready to provide complete information about this important home information service now. . . and full customer support after you've made your purchase. Just call toll free. . .

800-257-5114

**In New Jersey call:
(609) 452-1511.**



TRS-80 and Radio Shack are registered trademarks of Tandy Corp.

DOW JONES
NEWS/RETRIEVAL®

DOW JONES NEWS/RETRIEVAL is a registered trademark of Dow Jones & Company, Inc.

Will micros change the way we look at film?

Celluloid CPUs

by Michael E. Nadeau
80 Microcomputing staff

The work of large computers in producing special effects for movies such as *Star Wars* and *Close Encounters* is well known. But few know of the mark micros are making for themselves in Tinseltown.

"There is really a lot happening (in the movie business) with microcomputers," said Richard Shaw, an expert on computer applications for the film industry. There are two main areas where micros are involved in the actual producing of a movie: graphics generation and motion control. (Motion control is the way perspective is kept between camera movement and the action being filmed; i.e., a camera may pan an action shot at a different speed than that action—computers help coordinate this.) The types of computers used in graphics and motion control are usually dedicated, eight-bit, 64K S-100-based machines, he said.

Shaw sees television benefitting most from the use of computers in film production. "Television allows for excellent control by computers. . . because of their high-resolution screens," he said. Hollywood, however, is using micros more as their advantages become apparent.

The China Syndrome

One movie that pioneered the use of micros was *The China Syndrome*. Since the movie simulated an accident at a nuclear power plant an exact reproduction of a reactor control room was built. The crew now needed a way to make all the control boards, lights and gauges behave as they would in an actual emergency.

One person who had a hand in creating the system that ran the movie's control room was Michael Fink, an electronics consultant for the film. Hardware or large com-

puters were too expensive for the control devices; they decided to use a micro. *China Syndrome* was filmed in 1978, just when the micro industry was beginning. At this time it was very difficult to get a micro in the time the movie company needed it. One company, Compal, was not only able to supply a micro within six weeks, but arrangements were made for the movie company to use it for one year.

The Compal 80 was an 8080A-chip-based machine of 64K. With this computer, "We had to simulate a nuclear reactor going nuts," Fink said. Essentially what they did was hook up the Compal 80 to the control panels via the S-100 bus and use software

to control virtually all the action. The author of that software was Richard Hollander. Stuart Ziff, now working on the *Star Wars* sequel, *Revenge of the Jedi*, was responsible for all hardware interfacing. Fink's responsibility was making sure that the system got built.

This team accomplished what Fink considers a first in the movie industry: the use of a microcomputer in live action. The system was set up so at certain cues, an actor could run specific software from the control panel to simulate the proper action for that sequence. For example, Jack Lemmon would say a line—his cue to press a certain button. This button would start the

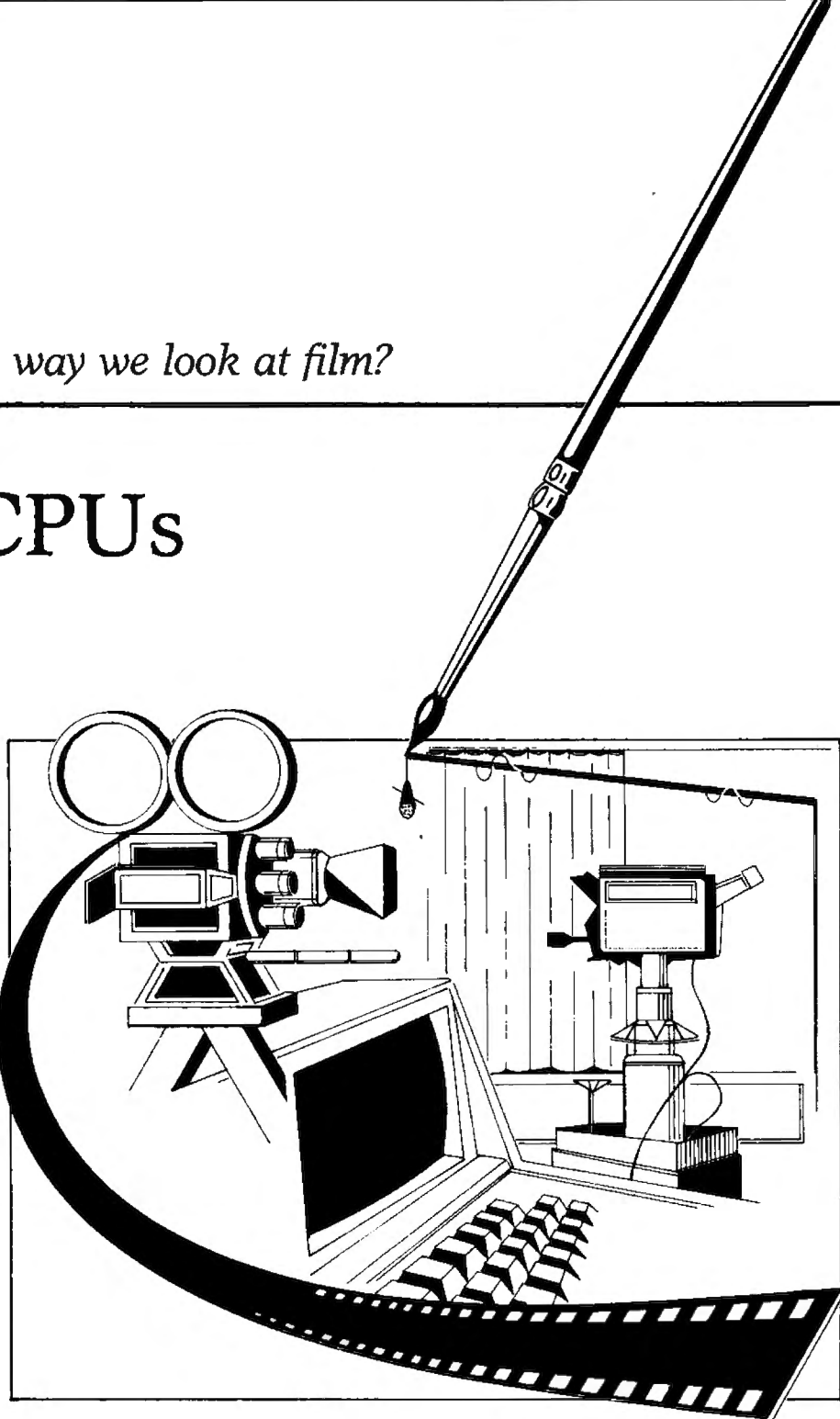

NEW HIGHER PRINTING SPEED, NEW LOWER PRINTER PRICE

High-speed printer

The Heath/Zenith 25 Printer is a heavy-duty, high-speed dot matrix printer that gives you sharp, clear printouts. It prints crisp, clear copy at speeds over 150 characters per second with quiet smoothness.

Baud rates from 110 to 9600 are user-selectable.

Versatile printer

The 25 prints the entire 95-character ASCII set in upper case and lower case with descenders, in a 9x9 matrix. Also, 33 block graphic characters – which are compatible with the Heath/Zenith 89 All-In-One Computer and the 19 Smart Video Terminal – let you create graphs and charts. All functions and timing are microprocessor-controlled.

Plug-in ribbon cartridges make ribbon replacement a no-mess snap.

The 25 works with most computers and terminals – using an RS-232C Serial Interface or a 20 mA current loop with handshaking control signals.

Low-priced printer

The 25 has all the features you've been looking for in a high quality, high-speed dot matrix printer – for only \$1095 in kit form, or for only \$1595 assembled and tested.

Free demonstration awaits you at your Heathkit Electronic Center †

Pick the store nearest you from the list below. And stop in today for a demonstration of the new Heath/Zenith 25 Printer. If you can't get to a store, send \$1.00 for the latest Zenith Data Systems Catalog of assembled commercial computers. We'll also send you a free copy of the latest Heathkit® catalog. Write to Heath Company, Dept. 035-894, Benton Harbor, MI 49022.

HEATH/ZENITH

Your strong partner

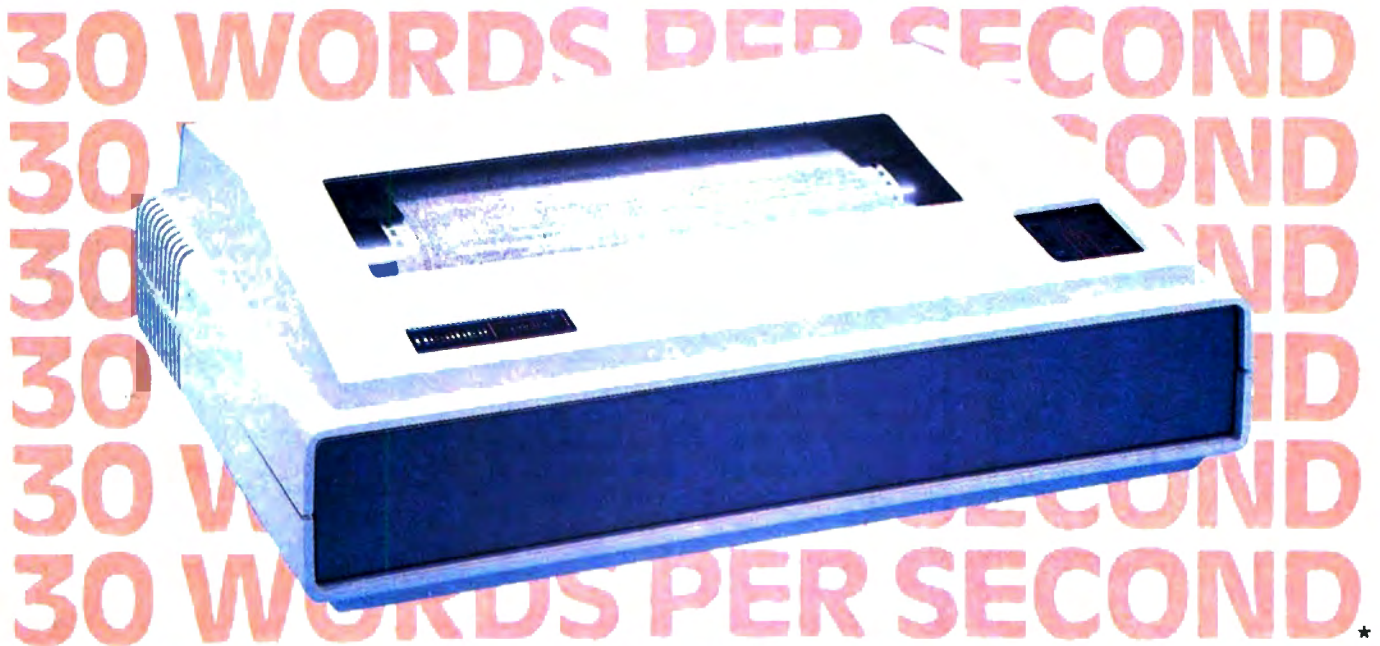

*150 characters per second

Visit your Heathkit Electronic Center†

Where Heath/Zenith Products are displayed, sold and serviced.

PHOENIX, AZ 2727 W. Indian School Rd. 602-279-6247	SACRAMENTO, CA 1860 Fulton Ave. 916-486-1575	ATLANTA, GA 5285 Roswell Rd. 404-252-4341	BALTIMORE, MD 1713 E. Joppa Rd. 301-861-4446	ST. PAUL, MN 1645 White Bear Ave 612-776-1211	ROCHESTER, NY 937 Jefferson Rd 716-424-2560	FRAZER, PA 630 Lancaster Pk (Rt 30) 215-647-5555	SAN ANTONIO, TX 7111 Blanco Rd 512-341-8876
ANAHEIM, CA 330 E. Ball Rd. 714-776-9420	WOODLAND HILLS, CA 22504 Ventura Blvd. 213-883-0531	CHICAGO, IL 3482-66 W. Devon Ave 312-583-3920	ROCKVILLE, MD 5542 Nicholson Lane 301-881-5420	BRIDGETON, MD 3794 McKelvey Rd 314-291-1850	N. WHITE PLAINS, NY 7 Reservoir Rd 914-761-7690	PHILADELPHIA, PA 6318 Roosevelt Blvd 215-288-0180	MIOVALE, UT 58 East 7200 South 801-566-4626
CAMPBELL, CA 2350 S. Bascom Ave. 415-377-8920	DENVER, CO 5940 W. 38th Ave. 303-422-3408	DOWNS GROVE, IL 224 Ogden Ave 312-852-1304	PEABODY, MA 242 Andover St (Rt. 114) 617-531-9330	OMAHA, NE 9207 Maple St 402-391-2071	CLEVELAND, OH 28100 Chagrin Blvd 216-292-7553	PITTSBURGH, PA 3482 Wm. Penn Hwy 412-824-3564	ALEXANDRIA, VA 6201 Richmond Hwy. 703-765-5515
EL CERRITO, CA 6000 Potrero Ave. 415-236-8870	AVON, CT 395 W. Main St. (Rt. 44) 203-678-0323	INDIANAPOLIS, IN 2112 E. 62nd St. 317-257-4321	WELLESLEY, MA 165 Worcester Ave. (Rt. 9) 617-237-1510	ASBURY PARK, NJ 1013 State Hwy 35 201-775-1231	COLUMBUS, OH 2500 Morse Rd 614-475-7200	WARWICK, RI 558 Greenwich Ave 401-738-5150	VIRGINIA BEACH, VA 1055 Independence Blvd. 804-460-0997
LA MESA, CA 8363 Center Dr. 714-461-0110	HIALEAH, FL 4705 W. 16th Ave. 305-823-2280	MISSION, KS 5960 Lamar Ave 913-362-4486	DETROIT, MI 18645 W. Eight Mile Rd. 313-535-6480	FAIR LAWN, NJ 35-07 Broadway (Rt. 4) 201-791-6935	TOLEDO, OH 48 S. Byrne Rd 419-537-1887	DALLAS, TX 2715 Ross Ave 214-826-4053	SEATTLE, WA 505 8th Ave. N 206-682-2172
LOS ANGELES, CA 2309 S. Flower St. 213-749-0261	PLANTATION, FL 7173 W. Broward Blvd. 305-791-7300	LOUISVILLE, KY 12401 Shelbyville Rd 502-245-7811	EAST DETROIT, MI 18149 E. Eight Mile Rd. 313-772-0416	AMHERST, NY 3476 Sheridan Dr 716-835-3090	WOODLAWN, OH 10133 Springfield Pike 513-771-8850	FORT WORTH, TX 6825-A Green Oaks Rd 817-737-8822	TUKWILA, WA 15439 53rd Ave. S 206-246-5358
POMONA, CA 1555 N. Orange Grove Ave. 714-623-3543	TAMPA, FL 4019 W. Hillsborough Ave. 813-866-2541	KENNER, LA 1900 Veterans Mem. Hwy 504-467-6321	HOPKINS, MN 101 Shady Oak Rd 612-938-6371	JERICHO, LI, NY 15 Jericho Turnpike 516-334-8181	OKLAHOMA CITY, OK 2727 N. W. Expressway 405-848-7593	HOUSTON, TX 1704 W. Loop N 713-869-5263	VANCOUVER, WA 516 S. E. Chaklov Dr #1 206-254-4441
REDWOOD CITY, CA 2001 Middlefield Rd. 415-365-8155							MILWAUKEE, WI 5215 W. Fond du Lac 414-873-8250

†Heathkit is a registered trademark of Heath Company. Heath Company and Veritechnology Electronics Corporation are wholly-owned subsidiaries of Zenith Radio Corporation. Heathkit Electronic Centers are operated by Veritechnology Electronics Corporation

CP-208

**FOR TRS-80 MODEL I OR III
AND SOON FOR THE NEW
IBM PERSONAL COMPUTER!**

- ★ **MORE SPEED**
10-20 times faster than Level II BASIC.
- ★ **MORE ROOM**
Very compact compiled code plus VIRTUAL MEMORY makes your RAM act larger. Variable number of block buffers, 31-char. unique word-names use only 4 bytes in header!
- ★ **MORE INSTRUCTIONS**
Add YOUR commands to its 79-STANDARD-plus instruction set!
Far more complete than most Forths: single & double precision arrays, string-handling, clock, more.
- ★ **MORE EASE**
Excellent full-screen Editor structured & modular programming
Word search utility
THE NOTEPAD letter writer
Optimized for your TRS-80 or IBM with keyboard repeats, upper/lower case display driver, full ASCII, single- & double-width graphics, etc.
- ★ **MORE POWER**
Forth operating system
Interpreter AND compiler
8080 or 8088 Assembler
(Z80 Assembler also available for TRS-80)
Intermix 35- to 80-track disk drives
Model III and IBM can read, write and run each other's and Model I diskettes!
VIRTUAL I/O for video and printer, disk and tape (10-Megabyte hard disk available)



**THE PROFESSIONAL FORTH
FOR TRS-80**

(Thousands of systems in use)

MMSFORTH Disk System V2.0 (requires 1 disk drive, 32K RAM) For Radio Shack TRS-80 Model I or III \$129.95
For IBM Personal Computer (advance order) \$249.95

**AND MMS GIVES IT
PROFESSIONAL SUPPORT**

- Source code provided
- MMSFORTH Newsletter
- Many demo programs aboard
- MMSFORTH User Groups
- Inexpensive upgrades to latest version
- Programming staff can provide advice, modifications and custom programs, to fit YOUR needs
- MMSFORTH UTILITIES DISKETTE includes FLOATING POINT MATH (L2 BASIC ROM routines plus Complex numbers, Rectangular-Polar coordinate conversions, Degrees mode, more), plus a full Forth-style Z80 ASSEMBLER, plus a powerful CROSS-REFERENCER to list Forth words by block and line. All on one diskette (requires MMSFORTH V2.0, 1 drive & 32K RAM). \$39.95*
- FORTHCOM, communications package provides RS-232 driver, dumb terminal mode, transfer of FORTH blocks, and host mode to operate a remote TRS-80 (requires MMSFORTH V2.0, 1 drive & 32K RAM). \$39.95*
- THE DATAHANDLER V1.2, a very sophisticated database management system, operable by non-programmers (requires MMSFORTH V2.0, 1 drive & 32K RAM). \$69.95*
- MMSFORTH GAMES DISKETTE real-time graphics & board games w/source code. Includes BREAKFORTH, CRASHFORTH, CRYPTOQUOTE, FREEWAY, OTHELLO & TICTACFORTH (requires MMSFORTH V2.0, 1 drive & 32K RAM). \$39.95*

Other MMSFORTH products under development

FORTH BOOKS AVAILABLE

- MMSFORTH USERS MANUAL - without Appendices, for non-owners \$17.50*
- STARTING FORTH - best companion to our manual \$15.95*
- THREADED INTERPRETIVE LANGUAGES - advanced, excellent analysis of MMSFORTH-like language. \$18.95*
- PROGRAM DESIGN & CONSTRUCTION intro to structured programming, good for Forth \$13.95*
- FORTH -79 STANDARD MANUAL - official reference to 79-STANDARD word set, etc. \$13.95*
- FORTH SPECIAL ISSUE, BYTE Magazine (Aug. 1980) - we stock this collector's item for Forth users and beginners \$4.00*

* - ORDERING INFORMATION: Software prices include manuals and require signing of a non-transferable single-user license. Describe your Hardware. Add \$2.00 S/H plus \$3.00 per MMSFORTH and \$1.00 per additional book. Mass. orders add 5% tax. Foreign orders add 20% UPS COD, VISA & MIC accepted, no unpaid purchase orders please.

Send SASE for free MMSFORTH information.
Good dealers sought!

Get MMSFORTH products from your
computer dealer or

MILLER MICROCOMPUTER SERVICES (K5)

61 Lake Shore Road, Natick, MA 01760
(617) 653-6136

"This team accomplished what Fink considers a first in the movie industry: the use of a microcomputer in live action."

software, which flashed lights and made dials "go crazy."

Fink said the great advantage to this system was that it gave the actors the chance to play with the set, and the set gave the actors cues. The system was flexible enough that if someone wanted to change it, it could be done in a matter of seconds, "saving days in shooting," he said. The set itself took only six weeks to build.

The system had 144 output ports, representing the 144 items the Compal 80 had to control. Variable voltage analog signals were sent to make the gauges go awry, and relay boxes were placed behind each light. Eight miles of cable were used on the set.

A cassette system stored each sequence. "We didn't need speed," Fink said. They would load the tape in the morning, then write what they did to the computer at lunchtime and again in the evening. When they later were doing inserts (as the term implies, the inserting of sequences into parts of the film), they could pull cassette number 233 and use that sequence where they needed it.

Fink said the same system could not have been built as cheaply nor as quickly had they used manual switches and other hardware controls. Software control for the types of special effects used in *The China Syndrome* was new ground in the film industry at the time. Fink said today one could just buy a 64K TRS-80 Model II and "literally buy the software off the shelf."

Blade Runner

Another movie, yet to be released at this writing, used a micro with one of its props during production. *Blade Runner* is a science fiction film based on the book, *Do Androids Dream of Electric Sheep?*, by Philip K. Dick. The plot, set in the future, is about a bounty hunter who hunts down a band of renegade androids. The film was produced by Filmways Pictures and had a \$15 million budget.

Again, Fink was involved in the work done with micros in this film. He and a partner, Linda Fleischer, were in charge of all "hi-tech action props." In the film, there is a vehicle called a Spinner. Based on a conventional car chassis, the Spinner featured a complex control panel. The original plan was to use a Horizon North Star computer to control the dials, digital readouts, and gauges—much the same way the Compal 80 was used in *The China Syndrome*.

Four Spinners were built: two driving versions, one light-weight flying version, and a

process car controlled by the microprocessor system. Fink and Fleischer had to build an interactive system that would simulate the proper instrument behavior in two circumstances: flight and driving pursuit. The instruments included thirteen alphanumeric displays, seven analog displays, and displays in both English and Japanese characters.

"There were a tremendous amount of things in one small vehicle," Fink said. Unfortunately, the efforts of Fink and Fleischer were almost for naught. "Almost none of the system was used... most of it was run by switches (in the actual filming)," Fink said. Apparently in this application there was a little technological overkill. But, Fink said, "You give them more than they ask for."

Movies, Money and Micros

The reason micros are seeing more use in movie making is simple: They save time and money. And micros are not used only in the production of movies. Many directors have discovered that by using a micro or time-sharing on a mainframe they can keep track of their costs as they occur—a very important consideration in Hollywood these days.

"Up until recently it was nearly impossible to tell where the money was going until after the fact," Shaw said. A director or producer cannot apply cost controls until he knows where they are needed. A computer is very handy in this situation.

Other facets of the movie industry use micros as well. Several talent agencies use micros to keep track of clients. A growing number of screenwriters, Shaw included, use micros as word processors.

Shaw sees little resistance in the industry to microcomputers. "People are smart enough to see what is going on," he said. "Those unfamiliar with computing were a little afraid... (but) there is a tremendous turnaround of talent... (and) the new people know more about computers."

He said a lot of the people in movie production using computers often had an interest in physics or electronics, so computers came easily to them. Also, film makers tend to be "a little worried about expenses," Shaw said.

"You don't have to know about computers to use them," Shaw said. "Movies are the first love (of screenwriters, directors, producers, and so on). Computers should free you to apply your creativity. They just get rid of the tedium." ■

FASTER THAN ANY FLOPPY DISK DRIVE!

FOR LESS THAN \$40.00

Yes . . . through the power and flexibility of the LDOS Operating System, Galactic Software brings the TRS-80 user . . . memDISK.

By using a portion of the existing RAM in your TRS-80, memDISK will create a fully functional disk type device. This RAM based disk may be accessed as a normal disk drive with copy, backup, free, dir, save, load, dump, etc. You can even have your memDISK appear automatically everytime you boot your system by using the LDOS System (SYSGEN) feature. The amount of storage available on your memDISK is user selected from 1.5k to 28.5k. The access time of your memDISK device is guaranteed to be **FASTER THAN ANY FLOPPY DRIVE** available, and it's even faster than most hard drive systems. To assure reliability, memDISK even tests the RAM area it will use, before installing itself. Now you can do things with your system that were too slow or impossible before the memDISK system became available. Best of all memDISK involves no additional hardware of any sort, nothing to align, adjust, clean or break. It's all software! All this for as little as \$30 (when purchased with LDOS).

The memDISK system requires a minimum of a 32k, single drive, TRS-80 (Mod I or III) and the LDOS Operating System.

memDISK is just \$39.00 for LDOS owners or you can get Mod I or III LDOS 5.1.1 with memDISK for a package price of just \$159.00 complete. Source code is available to memDISK owner for \$50.00.

Also available from Galactic:

	PRICE	SHIPPING & HANDLING
1. FED - The LDOS File Editor	\$ 40	+ \$2
2. LED - The LDOS Text Editor	\$ 40	+ \$2
3. LC - The LDOS "C" Compiler	\$150	+ \$4
4. I/O MONITOR - The LDOS Disk Error Monitor	\$ 25	+ \$2
5. PDS - Partitioned Data Sets For LDOS	\$ 50	+ \$2
6. MAIL/FILE - The LDOS Compatible Mailing List System	\$159	+ \$4
7. EDAS - The LDOS Editor Assembler	\$ 79	+ \$4
8. FILTER PACKAGE - 13 useful LDOS Filters Complete with Source	\$ 60	+ \$3
9. LDOS & memDISK - An Unbeatable Combo	\$159	+ \$5
10. And of course Mod I or Mod III LDOS	\$129	+ \$5

If you order any two items listed, deduct 10% as a package discount.



11520 North Port Washington Road
Mequon, Wisconsin 53092

ORANGE MICRO JUST TURNED A PAGE IN PRINTER HISTORY.

OUR PRICES, SELECTION & SAME-DAY SHIPPING MAKE US COMPETITIVE...

NEC 8023 Outstanding Graphics, Print Quality & Performance



144 x 160 dots/inch • Proportional Spacing
• Lower case descenders • Nx9 dot matrix
• 8 character sizes • 5 unique alphabets
• Greek character set • Graphic symbols
• 100 CPS print speed • Bi-directional logic-seeking
• Adjustable tractors • Single-sheet friction feed • Vertical & horizontal tabbing

NEC 8023List \$795 **\$Call**
Dot Matrix

IDS Paper Tiger 560/Prism 80/132 Affordable Color, Speed



Dot Resolution Graphics • 9-wire staggered printhead • Lowercase descenders • Over 150 CPS • Bi-directional, logic-seeking
• 8 character sizes • 80-132 columns
• Hi-res dot graphics • Proportional spacing
• Text justifications

Prism 80List \$899 **\$700**
IDS Paper Tiger 560GList \$1395 **\$1100**
Prism 132 (Color)List \$1995 **\$1895**

NEC Spinwriter 7700 & 3500 Daisy Wheel Quality Leader



High speed, letter quality • 55/33 CPS
• Typewriter quality • Bi-directional plotting & proportional spacing • Quiet • OCR quality print • Hi-res plotting/graphing • Quick change ribbon • Optional cut-sheet feeder, horizontal or bidirectional tractors • Prints up to 8 copies

NEC Spinwriter RO
Serial Parallel 77xxList \$3055 **\$2575**
35xxList \$2290 **\$1975**

The Epson Series. High-Quality Printers at a Low Price.



Epson MX70

Super low priced dot resolution graphics
• 5 x 7 dot matrix • User replaceable printhead
• Top of form • 80 CPS optional friction feed
• 10" paper width

Epson MX70List \$450 **\$390**



Epson MX80/MX80FT

9 x 9 dot matrix • Lower case descenders
• 80 CPS • Bi-directional • Logic seeking
• 40, 66, 132, columns per line • 64 special graphic characters: TRS-80 Compatible
• Forms handling • Multipage printing
• Adjustable tractors

Epson MX80List \$645 **\$Call**
Epson MX80FTList \$745 **\$Call**

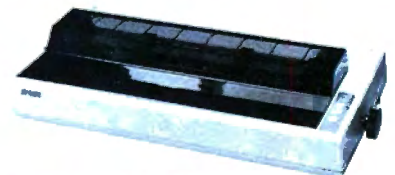

Epson MX100

Same basic features as the MX80 • Plus friction feed for single sheets • Plus 15" wide carriage • Dot Resolution Graphics

MX100List \$995 **\$Call**

Full Line of Epson Accessories

Anadex 9501 High Speed, Commercial Duty Plus Graphics



Dot graphics • Wide carriage • 11 x 9 dot matrix • Lower case descender • Dot resolution graphics • Bi-directional, logic seeking • Up to 200 CPS • RS 232 Serial & Parallel • Forms control • X-On/X-Off • Up to 6 part copy

Anadex 9501List \$1650 **\$1350**

INTERFACE EQUIPMENT

Complete stock of options, cables and accessories.

GRAPPLER APPLE INTERFACE \$175
CCS APPLE SERIAL Interface & Cable \$150
ORANGE INTERFACE for Apple II
Parallel Interface Board and Cable \$110
NOVATION D-CAT direct connect modem \$180
COMPLETE STOCK OF EPSON ACCESSORIES \$Call
CUSTOM PRINTER CABLES FOR Apple, Atari, IBM,
TRS-80 (all models) \$Call
HAYES MICROMODEM \$300
PRINTER STANDS: Large \$99
Small \$25
PRINTER RIBBONS—Most Types \$Call

WE'RE NOW



Red Baron

COMPUTER PRODUCTS

OUR PEOPLE MAKE US EXPERTS.

Malibu 200 Dot Matrix & Letter Quality in One Printer



200 CPS standard • Letter quality font
• 12 optional fonts • Bi-directional logic
seeking • 19 x 18 dot matrix • Expanded
characters (2x, 4x) Optional • Dot resolution
graphics of 144 x 120 • Underlining

Malibu 200List \$2995 **\$2600**

Okidata 82A Hi-Res & TRS-80 Block Graphics



120 CPS • Bi-directional printing • Logic
seeking • Double width & condensed printing
• Friction & tractor feed standard • Font
selection, character pitch & line spacing are
program controllable

Okidata 82AList \$799 **\$Call**

Centronics 739 Crisp Dot-Matrix Characters



Graphics & word processing print quality
• N x 9 dot matrix • suitable for word
processing • Underlining • Proportional
spacing • Right margin justification • Serif
typeface • 80/100 CPS • 9 1/2" pin feed/friction
• Optional 2 Color Kit

Centronics 739-1List \$695 **\$Call**

Centronics 739-3List \$795 **\$725**

Our People, Our Product: Both Are Specialized.

Because our salespeople are printer specialists, they know the capabilities of each printer—and how to match one to your exact need. Red Baron's volume stocking assures a low, low price on a wide array of major brands. We're sure you'll like the product and services you get from Red Baron, and we know you'll love our Customer Benefit Package; an exclusive at Red Baron.



Customer Benefit Package

1. Free Expert Consultation. Before you buy, after you buy. **2. Toll-Free Ordering.** There's never a toll charge when you place your order at Red Baron. **3. Free Catalog.** Get your informative catalog with printer comparison chart and character samples today! **4. Warranty.** The manufacturer's warranty applies where applicable. **5. Same-Day Shipping.** Your order is sent the same day when you call before 11:00 a.m. **6. Free/MasterCard & Visa.** Call us toll-free and charge your printer to your credit card. **7. We Stock What We Sell.** No bait and switch, no hassle. We make every effort to keep a large stock of our advertised products.

Televideo CRT's Price, Performance & Reliability



910CList \$699 **\$600**
920CList \$995 **\$770**
925CList \$995 **\$750**
950List \$1195 **\$970**

Here's how to order.

Phone orders are welcome; same-day shipment on orders placed before 11:00 a.m. Free use of MasterCard and Visa. CODs accepted. Personal checks require 2 weeks clearance. Manufacturer's warranty included on all equipment. Prices subject to revision.



CALL FOR
FREE CATALOG

TOLL FREE

1-800-854-8275 CA, AK, HI
(714) 630-3322

Orange Micro Retail Stores

Sherman Oaks: 13604 Ventura Blvd. (213) 501-3486
Anaheim: 3150 La Palma, # 1 (714) 630-3622
Santa Clara: 3216 Scott Blvd. (408) 980-1213



Red Baron

COMPUTER PRODUCTS

1100 N. TUSTIN
ANAHEIM, CA 92806



Sculpting the Aurora Borealis.

Northern Lights

by Bert Latamore
Desktop Computing staff

I want to make things that cannot be designed without a computer. I am making an effort to understand what the computer is uniquely capable of doing." Sculptor Rob Fisher did not always profess such a unique approach to his sculpting. The sheer magni-

tude of some recent projects, however, persuaded him to research the advantages of computer graphics; more specifically he harnessed CAD/CAM (Computer-Aided Design/Computer-Aided Manufacturing) and advanced vector graphics techniques creating a form of sculpture so new it hasn't been named.

When commissioned to create a five-story hanging construction for Playboy's Atlantic City Casino, Fisher set out two years ago to capture the ethereal grace of the Aurora Borealis.

With 5,000 pieces ranging in size from

four inches to forty feet working together in complex and constantly shifting ways, *Northern Lights* was a designer's Chinese puzzle nightmare. It was designed to be viewed from ground level and the four upper stories of the casino. The engineering problems alone were immense, and the creative questions were staggering.

To design it, Fisher needed to make a special model, one which would accurately show the flexing of the various members and locate the center of gravity of the piece. It had to allow easy judgement of single components and whole sections and in-

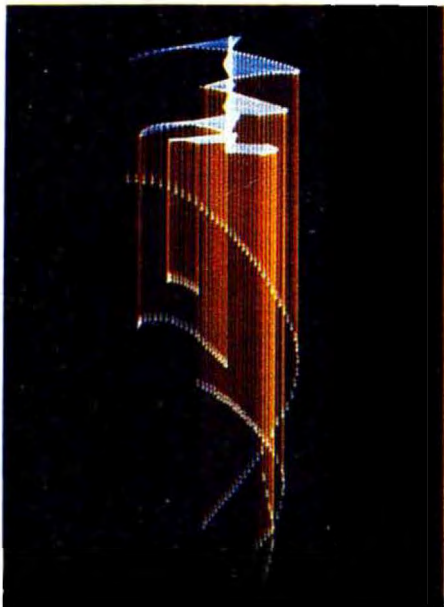

Photo 1. Perspective of sculpture in space
104 • 80 Microcomputing, May 1982

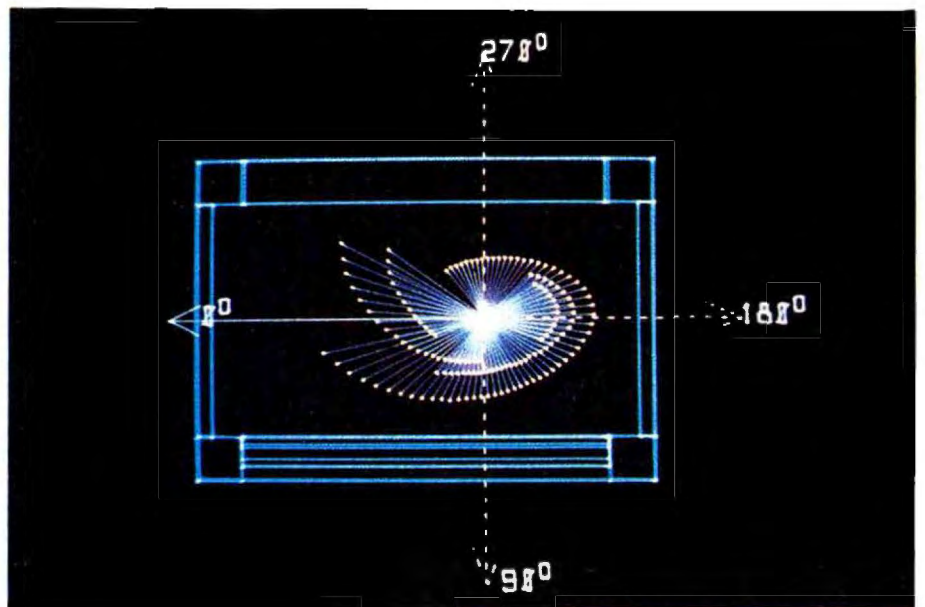

Photo 2. Plan view schematic with axial indicators

“... sculpture is a three-dimensional event; you want to preview it from as many... angles as possible.”

stantly show the effects of each change on the entire work. It also needed to represent the relationship between the sculpture and the then unbuilt building it would go into. “As I started to contemplate constructing the model it became unmanageable,” he commented.

No scale model would accurately duplicate the final piece; the only way to design it seemed to be to build a full size model at enormous cost and effort, hang it somewhere and keep a crew of workmen busy for a year or more making alterations.

“At the same time I was contemplating this problem, I met an architectural student who was taking a computer graphics course,” he commented. The student, from nearby Penn State University, introduced Fisher to a research laboratory director who referred him to Frederick R. Stocker, a computer graphics analyst with more than 10 years experience in CAD/CAM research, including design work on the simulation used by the National Aeronautics and Space Administration’s Skylab project.

Mutually Delighted

Stocker, who has interests in both science and art, and Fisher, who holds an MIT engineering degree, were mutually delighted. Stocker was pleased to have a project as creative as *Northern Lights*, and Fisher was surprised at what Stocker’s customized Adage Model 30 minicomputer could do.

“I knew we were going to see different views of the sculpture,” Fisher explained. This is important because “sculpture is a three-dimensional event; you want to preview it from as many different angles as possible.”

The computer, in fact, allowed him to see it from the top, side and a simulated view from any of the halls that open onto it. In spite of Fisher’s initial fears, the computer proved as interactive as a good word processor.

“It was the terrific ability to make an engineering decision and immediately see its visual effect which so astonished me,” Fisher revealed.

They started with a conceptual model and developed specifications on each component using a combination of computer research and physical testing. As they fed it new data, the computer constantly updated the model, automatically monitoring engineering concerns.

When they finished the initial design, the Adage indicated it weighed 1,500 pounds and placed its center of gravity a foot to one

side of the central column. They spent several months refining the design, trimming its weight to 600 pounds and moving the center of gravity into the central column to avoid putting torque into the roof beam it would hang from.

Computer Tricks

At the same time, Fisher redesigned the veils, meticulously polishing his work. And the Adage, which Stocker described as an older minicomputer with capabilities not too different from those of many of today’s micros, showed some of its tricks.

“The computer looks at data in a very cold, objective way,” Fisher explained. “It asked questions I would never have thought of like ‘What if you flatten out the data and present it in a graph?’”

The graph was invaluable in locating spots where the sculpture’s curves were not correct and needed reworking.

Working With Reality

One of Stocker’s main concerns was ensuring they were working with reality. “It’s tricky because you can show things that are impossible to build,” Stocker said.

CAD/CAM techniques are being used successfully in bridge, automobile and aircraft design, however, so it is possible for

experienced operators to control their computers.

“Ultimately,” Stocker commented, “manufacturing engineers will do their design on the screen and push a button to have it made.”

Although *Northern Lights* was not built quite that easily, the computer did make all the measurements and print complete construction instructions automatically.

The project proved to be the ultimate test of Stocker’s experimental CAD/CAM programs. When he compared the finished work to his computer model he found it accurate to within two inches.

A Profound Effect

The experience had a profound effect on the sculptor. In fact, Fisher, whose work includes fountains, bank facades, mobiles and a 35-foot tall hanging sculpture, started studying Fortran and bought an ENS graphics package driven by a DEC mainframe.

Fisher looked at several microcomputers but found they only offered raster graphics. He felt they could be used for rough initial designs, but compared to the mainframe’s vector system they were unsuitable for detailed design work of such complexity.

The New Work

Fisher’s new work will be even more ambitious than the first. Like *Northern Lights*, it will consist of a large number of columns hanging in space. The shape will resemble a prism standing on end, giving it the cross-section of a triangle with the corners cut off. It will be eight stories high.

Fisher plans to model a spiral galaxy directly from astronomical photographs on his computer screen superimposed over the prism of columns. He will put a six-inch-long polished brass fitting at each place where a column intersects the design of the galaxy. He expects to use about 1,000 of them. This, he admitted, simplifies the galaxy by a proportion of 200 million to one, but it brings it into human view.

One of a Kind

Fisher believes he is the only sculptor designing large-scale pieces on a computer, although he knows of one artist who uses a machine to check his calculations on large standing metal constructions he designs with traditional methods.

The computer has changed Fisher’s art, and he does not expect he will ever be the same. “It was an entirely new approach for me,” he said. “It has changed my way of thinking.” ■

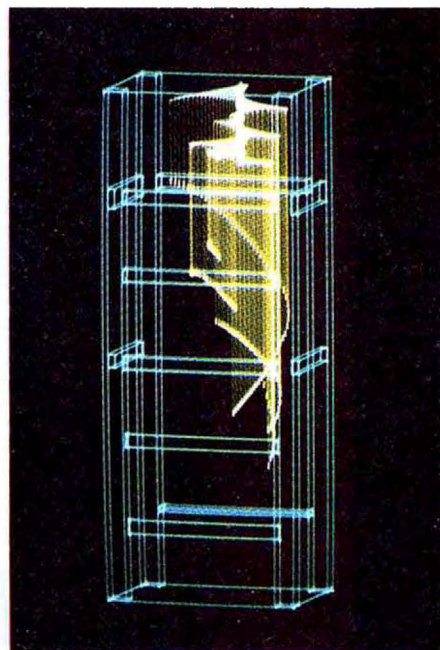

Photo 3. Perspective of sculpture from casino floors



Music and sound effects for your games.

Programmable Sound Generator

Program Listing 1

```
10 '
20 CLS :PRINT** * PROGRAM TO GENERATE AND PLAY RANDOM SOUNDS THROUGH PSGs *
**
30 PRINT" Disk BASIC version, June 1981"
40 ' Program requires a nine-voice or 15-voice PSG Music Board
50 ' with a hardware metronome.
60 DEF FN A-Z :DIM A$(2000,2) :ND=276 :MB=309 :REM Number of bytes of machine language programs
70 K1=0 :M=0 :L=0 :U0=0 :REM Initialize some values
80 F=0 :REM Flag for first time through
90 PRINT :PRINT" Loading - - - - -" :PRINT

100 OUT 4,0 :REM Reset all PSGs
110 FOR X=0 TO MB-1 :REM PLAYBK driver in machine language
120 READ D :POKE -8192+X,D
130 NEXT X
140 FOR X=0 TO Mb-1 :REM RNDM machine language driver
150 READ D :POKE -7680+X,D
160 NEXT X
170 DATA 211,4,62,7,50,240,223,221,42,246
180 DATA 223,221,78,0,221,70,1,237,67,254
190 DATA 223,221,110,254,221,102,255,41,229,209
200 DATA 221,25,221,34,250,223,41,229,209,221
210 DATA 42,246,223,221,25,221,34,252,223,1
220 DATA 2,0,42,246,223,9,126,50,239,223
230 DATA 230,7,40,12,50,240,223,219,0,254
240 DATA 255,40,250,126,24,4,50,240,223,134
250 DATA 211,0,42,250,223,9,126,254,1,40
260 DATA 38,254,3,40,34,254,5,40,30,254
270 DATA 13,40,54,211,1,254,6,42,252,223
280 DATA 9,126,211,2,204,209,224,3,3,42
290 DATA 254,223,41,175,237,66,32,180,201,211
300 DATA 1,95,221,42,252,223,221,9,221,126
310 DATA 1,211,2,29,123,211,1,221,126,0
320 DATA 211,2,205,209,224,24,216,58,239,223
330 DATA 95,42,252,223,9,126,253,33,241,223
340 DATA 203,123,205,198,224,203,115,205,198,224
350 DATA 203,107,205,198,224,203,99,205,198,224
360 DATA 203,91,205,198,224,195,117,224,32,3
370 DATA 253,35,201,253,119,0,253,35,201,253
380 DATA 33,241,223,58,239,223,95,203,123,22
390 DATA 128,205,253,224,203,115,22,64,205,253
400 DATA 224,203,107,22,32,205,253,224,203,99
410 DATA 22,16,205,253,224,203,91,22,0,205
420 DATA 253,224,201,32,3,253,35,201,58,240
430 DATA 223,130,211,0,62,13,211,1,253,126
440 DATA 0,211,2,253,35,201
450 '
500 DATA 211,4,58,249,223,183,32,63,237,95
510 DATA 253,33,51,227,253,119,0,237,95,253
520 DATA 119,1,221,42,246,223,221,110,254,221
530 DATA 102,255,229,193,11,237,67,254,223,221
540 DATA 113,0,221,112,1,41,229,209,221,42
550 DATA 246,223,221,25,221,34,250,223,41,229
560 DATA 209,221,42,246,223,221,25,221,34,252
570 DATA 223,17,18,0,221,42,246,223,221,25
580 DATA 205,31,227,221,119,0,221,42,250,223
590 DATA 221,25,205,31,227,230,15,254,0,40
600 DATA 247,254,2,40,243,254,4,40,239,254
610 DATA 14,40,235,254,15,40,231,221,119,0
620 DATA 221,42,252,223,221,25,254,7,40,2
630 DATA 24,17,205,31,227,230,63,79,230,48 :REM Change 48 to 56
640 DATA 254,48,40,2,24,242,121,24,110,254 :REM and change 48 to 56
650 DATA 6,48,30,254,13,48,33,254,0,40 :REM to turn off all noise chann

els
660 DATA 46,254,9,40,42,254,10,40,38,254
670 DATA 1,40,45,254,3,40,55,254,5,40
680 DATA 68,24,73,205,31,227,230,31,24,69
690 DATA 205,31,227,230,15,254,0,48,2,24
700 DATA 245,254,15,40,241,24,52,205,31,227
710 DATA 230,31,254,3,56,247,24,41,205,31
720 DATA 227,183,40,25,230,15,254,14,56,38
730 DATA 24,242,205,31,227,183,40,11,230,3
740 DATA 254,3,56,24,24,242,205,31,227,125
750 DATA 254,14,56,248,24,3,205,31,227,221
```

Program Listing 1 Continues

Matt Robins

4101 Arch Drive #6

Studio City, CA 91604

A computer-controlled synthesizer capable of nine simultaneous voices can be yours for about \$125 in parts—providing you already have a disk-equipped TRS-80 Model I. You can build a stereo PSG (Programmable Sound Generator) music board with some astounding software-controlled features, not to mention automatic "player-piano" capabilities, wherein the music is synthesized anew whenever the computer plays the digitally encoded score.

General Instrument designed some complex LSI music chips that were aimed at the arcade/games market, but are easy to interface to any microcomputer bus. At \$11-12 apiece, the AY-3-8910/8912 PSG chips can each produce three simultaneous voices with an eight-octave range, governed by one of several envelopes or 16 levels of volume. Variable noise output is also provided.

The PSG chips suffer some limitations: they are slightly off frequency, especially in high octaves; their digital-to-analog converters produce slight clicks during extended envelope decay; only square wave output is available. These PSG chips are precursors of more accurate synthesizer chips to come. Even today, each of the above limitations can be solved in hardware; for example, a square-to-sine wave converter is easy to build.

The limitations of PSGs are overshadowed by the astonishing flexibility afforded by microprocessor control. Let us look at some examples.

- Sound effects generation for computer games. The PSG music board provides stereo outputs for realistic sound effects.

- Music synthesizer: You can encode and play repeatedly a multi-part score. Limited percussion effects are possible.

- You can play random notes after some software "filtering"—elimination of very high notes, for example—to give pleasing cacophonies of ever-changing sounds.

- You can generate semi-random notes or chords. Software can impose musical scales, keys and chord progressions to

*“Next step in adding intelligence
might involve counting
beats, bars and phrases by software.”*

give “random symphonies” that are of some musical value.

- The computer can compose music—but only after a major programming and analytical effort.

- You can refine envelope control by storing envelopes in computer RAM. Envelopes, or attack-decay volume variations, allow the ear to differentiate between various classes of instruments. Envelopes occur on a relatively slow time scale, so the microprocessor can service several envelopes and perform other tasks at the same time.

- You can easily accomplish glissando and “note bending.” Around middle C, for example, the PSGs divide frequencies to produce 14 intervals for a semitone!

- Polyrhythms are programmable, with easy switching between time signatures. You can approximate triplet time. The noise sources on the PSGs limit percussion effects, but the computer-generated signals could trigger external percussion devices.

The list becomes longer if we consider what some simple hardware additions would give:

- Metronome with programmable pulse would give the music board the capability of “bending” time under software control. A triplet metronome running in parallel with the straight-time metronome would give true triplets.

- You could obtain true echo effects by employing multiple PSGs, each of which would duplicate the sounds of the primary PSG after some delay. The delays would be software-programmable.

- You could implement an intelligent synthesizer with as little as one microphone and an analog-to-digital converter. Software would analyze the loudness of a musical performance and trigger the PSGs to produce preset effects. A PSG music board could thus accompany, in real time, a musical performance. The next step in adding intelligence might involve counting beats, bars and phrases by software. The PSGs could trigger special effects at the end of a chorus, for example. If you input key changes into the computer, the computer could generate and play proper chords at preset or semi-random spots.

I will describe the construction of a nine voice PSG music board that is expandable to 15 voices and in/out port mapped. The music board incorporates a metronome that can resolve note durations from a whole note to 1/128th note. The music board

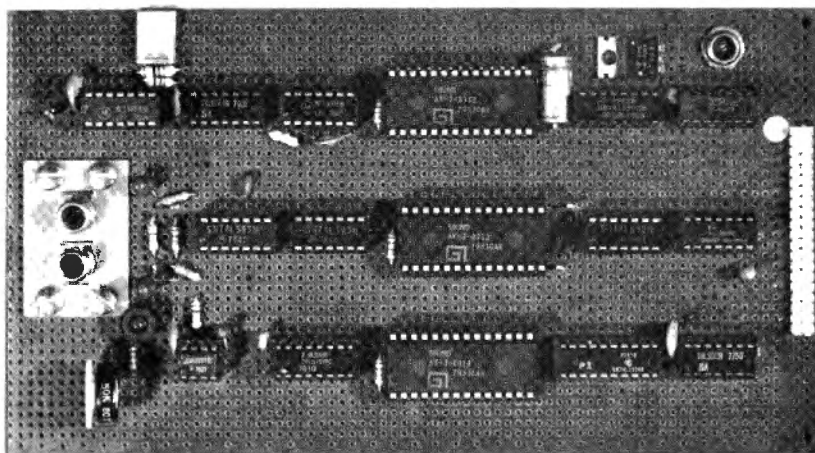

Photo 1. Prototype nine-voice PSG music board, wire-wrapped on a Vector board. The dot next to the header indicates pin 1 of the connector—equivalent to pin 2 of the TRS-80 Model I bus.

Program Listing 1 Continued

```

760 DATA 119,0,221,54,1,0,24,6,221,117
770 DATA 0,221,119,1,19,19,42,254,223,41
780 DATA 175,237,82,194,74,226,201,42,51,227
790 DATA 6,15,41,124,23,172,250,44,227,44
800 DATA 16,246,34,51,227,124,201,0,0
820 *
830 ' You may build a three-dimensional array in here,
840 ' but you must specify the number of notes in A%(0,0).
850 GOTO 970 :REM Or let RNDM build an array of 2000 notes
860 REM FAST PLAYBACK IN MACHINE LANGUAGE
870 IF F>0 THEN 880 ELSE F=2 :REM F=0 for first time through
880 POKE -8199,F:REM Flag transmitted to machine-language pgm.
890 DEFUSR0=-8192
900 PRINT :PRINT" ** PLAYBACK **"
910 K=VARPTR(A%(0,0))
920 IF K <= 0 THEN K1= 65536+K ELSE K1=K
930 PRINT" Array starts at", :PRINT K, :PRINT K1
940 M=CINT(K1/256) :L=K1-M*256
950 POKE -8201,M :POKE -8202,L
960 U0=USR0(A)
970 PRINT :PRINT" ** RANDOM ARRAY GENERATION **"
980 REM Number of notes generated will equal the array dimension.
990 DEFUSR1=-7680
1000 IF F=0 THEN POKE -8199,0 ELSE GOTO 1080 :REM Flag = 0 serves to add
PSG initialization specs first time around
1010 RESTORE
1020 FOR N=1 TO NB :READ A :NEXT N :REM Dummy READS
1030 FOR N=1 TO MB :READ A :NEXT N
1040 FOR N=1 TO 8 :REM Initial values for array--presets
1050 FOR J=0 TO 2
1060 READ A%(N,J)
1070 NEXT J,N
1080 K=VARPTR(A%(0,0))
1090 IF K <= 0 THEN K1=65536+K ELSE K1=K
1100 PRINT" Array starts at", :PRINT K, K1 :PRINT
1110 M=CINT(K1/256) :L=K1-M*256
1120 POKE -8201,M :POKE -8202,L
1130 U0=USR1(A)
1140 GOTO 860 :REM Loop back to PLAYBK driver
1150 REM INITIAL SETTINGS OF PSG'S
1160 DATA 248,7,56 :REM Enable tones on all PSGs
1170 DATA 240,13,13 :REM Envelope shape/cycle = sustain on all but Center
PSG
1180 DATA 8,13,15 :REM Envelope shape/cycle = single pulse for Center PSG
1190 DATA 240,12,80 :REM Envelope Coarse = 80, about 0.4 Hz
1200 DATA 8,12,16 :REM Envelope Coarse about 2 Hz for Center PSG
1210 DATA 248,8,16 :REM Channel A volume is envelope controlled on all PSG
S
1220 DATA 248,9,8 :REM Channel B is at half-volume
1230 DATA 248,10,4 :REM Channel C is at one-quarter volume
1240 END

```

The Scott Adams Adventure Series AN OVERVIEW

operates from an external power supply and provides low noise stereo outputs for playback through a standard stereo system. I include software drivers for playing music and for generating random notes.

Interfacing PSGs

Interested readers should obtain a copy of "AY-3-8910/8912 Programmable Sound Generator Data Manual" from General Instrument Corporation (Microelectronics Division, 600 West John Street, Hicksville, NY 11802). The heart of the PSG is a 16-register array that accepts information from the microprocessor data bus. Figure 1 shows a simplified diagram of the register array. Tone generation requires specifying 12 bits of data from a table of notes, so two registers are needed. PSG register 6, noise period, requires only five data bits. Register 7, enable, determines whether tone or noise or both will be output from a particular audio channel. Registers 8-10 determine audio amplitudes on a 16-step scale, or put the amplitudes under the control of an envelope. Registers 11 and 12 set the envelope period, while register 13 selects envelope shape to give a choice of several envelopes. Loading register 13, envelope shape/cycle, also triggers the attack/decay envelope. Register 14 or 15 is an auxiliary input/output port, not implemented in this application.

Before the PSG music board can accept either register address or data for latching to the PSGs, the microprocessor must first send a control word to the board. The control word is stored in its own latch and selects which combination of the three (or five) PSGs will be enabled. The three PSGs are arranged in a stereo spectrum: left, right and center. The control word, using a three-bit code, also requests a note duration from the metronome.

Next the PSG music board accepts two words from the microprocessor: the first one selects, or addresses, one of the 16 PSG registers (register address in Fig. 1); the second one stores the data in the selected register (bidirectional buffers in Fig. 1). Whether a word is latched as a control word, PSG register address or PSG data is determined by input/output port assignment, as shown in Fig. 2.

The control word is latched by the OUT 0 command. The most significant five bits select one or more PSGs. You may use bits D4 and D5 for easy expansion to five PSGs; the additional PSGs could be placed at left-center and right-center of the stereo spectrum. Alternatively, you can use these data bits to trigger, or select, external devices



I stood at the bottom of a deep chasm. Cool air sliding down the sides of the crevasse hit waves of heat rising from a stream of bubbling lava and formed a mist over the sluggish flow. Through the swirling clouds I caught glimpses of two ledges high above me: one was bricked, the other appeared to lead to the throne room I had been seeking.

A blast of fresh air cleared the mist near my feet and like a single gravestone a broken sign appeared momentarily. A dull gleam of gold showed at the base of the sign before being swallowed up by the fog again. From the distance came the angry buzz of the killer bees. Could I avoid their lethal stings as I had managed to escape the wrath of the dragon? Reading the sign might give me a clue to the dangers of this pit.

I approached the sign slowly.

And so it goes, hour after hour, as you guide your microcomputer through the Adventures of Scott Adams in an effort to amass treasures within the worlds of his imagination.

By definition, an adventure is a dangerous or risky undertaking; a novel, exciting, or otherwise remarkable event or experience. On your personal computer, Adventure is that and more.

For the user, playing Adventure is a dangerous or risky undertaking in that you better be prepared to spend many addictive hours at the keyboard. If you like challenges, surprises, humor and being transported to other worlds, these are the games for you. If you dislike being forced to use your common sense and imagination, or you frustrate easily, try them anyway.

In beginning any Adventure, you will find yourself in a specific location: a forest, on board a small spaceship, outside a fun house, in the briefing room of a nuclear plant, in a desert, etc.

By using two-word commands you move from location to location, manipulate objects that you find in the different places, and perform actions as if you were really there. The object of a game is to amass treasure for points or accomplish some other goal. Successfully completing a game, however, is far easier to state than achieve. In many cases you will find a treasure but be unable to take it until you are carrying the right combination of objects you find in the various locations.

How do you know which objects you need? Trial and error, logic and imagination. Each time you try some action, you learn a little more about the game. Which brings us to the term "game" again. While called games, Adventures are actually puzzles because you have to discover which way the pieces (actions, manipulations, use of magic words, etc.) fit together in order to gather your treasures or accomplish the mission. Like a puzzle, there are a number of ways to fit the pieces together; players who have found and stored all the treasures (there are 13) of Adventure #1 may have done so in different ways.

In finding how the pieces fit, you will be forced to deal with unexpected events, apparent dead ends and Scott's humor, which is one of the best parts of the puzzles.

If you run into a barrier like not being able to discover more rooms, don't give up. Play the game with some friends; sometimes they'll think of things you haven't tried.

While I pondered how to reach the throne room — which I was sure contained the treasures of Croesus — the fog grew thicker and the hours passed. I realized I would not be able to outwit Adams today...but maybe tomorrow. I marked my present location on my tattered map and began the long trip to the surface. As I dropped myself off to bed, I thought about other possible Adventures.

But enough for tonight. Tomorrow — another crack at the chasm.

—by Ken Mazur

Reprinted with permission from
PERSONAL COMPUTING MAGAZINE, FEB. 1980
Copyright 1980 PERSONAL COMPUTING MAGAZINE
1050 Commonwealth Ave., Boston, Mass. 02215

The 12 Scott Adams Adventures ¹⁹

Adventureland • Pirate Adventure • Mission Impossible •
Voodoo Castle • The Count • Strange Odyssey • Mystery
Fun House • Pyramid of Doom • Ghost Town • Savage
Island-Part 1 • Savage Island-Part 2 • Golden Voyage

WHO ARE YOU THIS TIME?

Are you the seeker of lost treasures in an enchanted realm of magical beings? Perhaps you're an astronaut, thousands of light years from earth, searching the galaxy's rim for the fabulous treasures and advanced technologies of a long-dead civilization. Maybe you're the plunderer of ancient pyramids in a maddeningly dangerous land of crumbling ruins and trackless desert wastes.

Imagine.

You wish to soar to other worlds, to behold wonders never beheld by mortal eyes, to dream unrestrained to the furthest limits of your imagination.

Imagine now that you can.

The ADVENTURE SERIES by Scott Adams has been reviewed by every major microcomputing magazine, receiving only the highest praise for its mind-puzzling challenge & refreshing originality.

Tens of thousands of adults and children have matched wits with the Adventure Master. Now, it's your turn. If you crave the challenge and panorama of the exotic, touched with sparkling humor, then the Adventure Series is for you.

With the incredible Adventure Series by Scott Adams,
**YOU ARE WHOMEVER YOU WANT TO BE,
 WHENEVER YOU WANT TO BE!**

Adventure
 INTERNATIONAL
 A DIVISION OF SCOTT ADAMS, INC.

1982
 BOX 3435, LONGWOOD FL 32750
 (305) 862-6917 (QUESTIONS)

ORDER FROM YOUR FAVORITE DEALER
 or CALL TOLL FREE (800) 327-7172
 (ORDERS ONLY PLEASE)

	SINGLE TAPE	12 PACK TAPE	SINGLE DISK	TRIPLE DISK	12 PACK DISK		
APPLE	\$19.95 24K	\$129.951 24K	\$29.95* 48K	\$69.95* 48K	—	Adventure Hint Book (All 12)	\$ 7.95
ATARI	\$19.95 24K	\$129.951 24K	—	\$39.95 40K	\$129.951 48K	Adventure Hint Sheet (Single)	1.00
CP/M (Z-80)	—	—	—	—	\$129.951	Commodore VIC (Cartridge)	39.95
TRS-80 MOD 1&3	\$19.95 16K	\$129.951 16K	—	\$39.95 32K	\$129.951 32K	T.I. 994 (Tape or Disk)	29.95
TRS-80 MOD 2	—	—	—	—	\$129.95	Requires Adventure Command Module	

*Scott Adams' Graphic Adventure Series
 Apple Disks-Full Color Hi-Res Graphics
 112 Adventure Hint Book Incl.

"A manual trimpot for adjusting metronome beats is connected to Z13."

like a triplet metronome, for example. The least significant three bits, D0-D2, are a code for the note duration requested from the metronome, as listed in Fig. 3.

IN 0 is the status of the hardware metronome. It can have one of two values that must be continually tested in a wait loop by the software while the previous note is

played. The computer spends most of its time in the wait loop. If the value at the input port is no longer equal to 255, then the previous note has ended and PSG registers can be updated to begin the next note. The first entry in updating is the control word via the OUT 0 command, which resets the metronome status to 255.

The OUT 1 command is the address latch for selected PSGs. It is equivalent to bus control 1 (BC1), described in the PSG Data Manual. As implemented in the music board, the microprocessor can address PSG registers 0-13. OUT 2 next latches actual data into the selected register. Whenever an OUT 1 or OUT 2 signal is received, the music board sends the required bus direction (BDIR) signal to the PSGs, as described in the manual. This assures that the data on the microprocessor bus gets latched by the bidirectional buffers of Fig. 1. Finally, OUT 4 is a RESET signal that sets

Program Listing 2

```

00100 ; ** PLAYBK **
00110 ; FAST PLAYBACK FOR PROGRAMMABLE SOUND GENERATORS
00120 ; SYNCHRONIZING ON WHOLE NOTE IMPLEMENTED
00130 ; TABLE OF ENVELOPE SHAPE/CYCLES IMPLEMENTED
00140 ; MATT. ROBINS, 6/9/81
00150
00160 ;
00170 CWORD EQU $-11H ;CONTROL WORD STORAGE
00180 CND EQU $-10H ;CURRENT NOTE DURATION
00190 LENV EQU $-0FH ;ENV. SHAPE/CYCLE, LEFT
00200 RENV EQU $-0EH ; RIGHT
00210 LCENV EQU $-0DH ; LEFT-CENTER
00220 RCENV EQU $-0CH ; RIGHT-CENTER
00230 CENV EQU $-0BH ; CENTER
00240 KLSB EQU $-0AH ;K=VARPTR(A(B,0)), POKED
00250 FL EQU $-7 ;FIRST TIME THROUGH FLAG
00260 K2 EQU $-6 ;=K+(N+1)*2, ADDR. OF A(B,1)
00270 K4 EQU $-4 ;=K+(N+1)*4, ADDR. OF A(B,2)
00280 NOTES EQU $-2 ;ACTUAL NUMBER OF NOTES
    
```

Program Listing 2 Continues

—ATTENTION ALL TRS-80® OWNERS—

No matter how your Model I, II, or III is used, whether it be business or pleasure, this product can benefit you.

The **FATIGUE FIGHTER™** reduces the operator fatigue (irritated, watery eyes and headaches) caused by the harsh white video display thereby making computer use more efficient and/or enjoyable. The graph at the right will help explain how it works. Superimposed on the standard eye sensitivity curve is the band pass curve of the **FATIGUE FIGHTER™** as recorded by a spectrophotometer. A marker is also on the graph at the ideal psychological tolerance color. As you can see, the green color of the **FATIGUE FIGHTER™** takes advantage of both eye sensitivity and psychological tolerance to make the display less irritating.

The **FATIGUE FIGHTER™** is made of tough 1/8 inch thick acrylic sheet which adds absolutely no distortion or fuzziness to the display and is industry proven to be an excellent material for optical filtering (e.g. lenses for laser safety goggles). It installs easily on all three TRS-80® models with a pressure sensitive adhesive which will not let the filter fall off yet allows easy removal if necessary. Finally, the black and silver border design makes it a perfect match for the computer styling.

If you want a **FATIGUE FIGHTER™** of your own but prefer not to order by mail, check with your local computer stores to see if they have them in stock. Otherwise follow the ordering instructions below.

TO ORDER: Send Name & Address Typed or Clearly Printed with Check or Money Order (U.S. FUNDS) for \$14.95 Each, Including Shipping. Canadian Orders add \$1.00 Each. All Other Foreign Orders Add \$2.00 Each for Shipping. NO CREDIT CARD ORDERS. CODs (U.S. ORDERS ONLY) are \$2.50 Additional Per Order & are Accepted by Mail or by Calling 904-378-2494 9-5 M-F. Florida Residents Add 4% Sales Tax. **ALL MAIL ORDERS MUST BE SENT TO THE U.S. ADDRESS**

TRS-80 IS A
TANDY CORP.
TRADEMARK.

SID SOUTHERN INNOVATIVE DESIGN
1520 NORTHEAST 12TH STREET
GAINESVILLE, FLORIDA 32601 ✓ 35

DEALER INQUIRIES INVITED

CANADIAN DEALERS ONLY— For pricing and ordering information contact:
MICRO-COMP ENTERPRISES, 955 Brock Rd. S., Unit 3, Pickering, Ont. L1W 2X9 Phone 416-839-4561

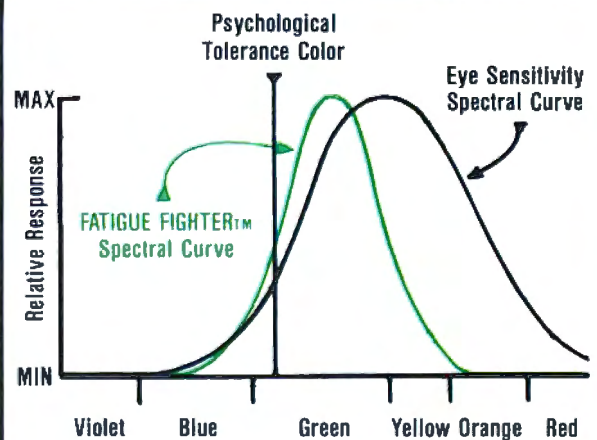

ALIEN DEFENSE

Defend Planet from
6 Different Types
of Alien Attacks

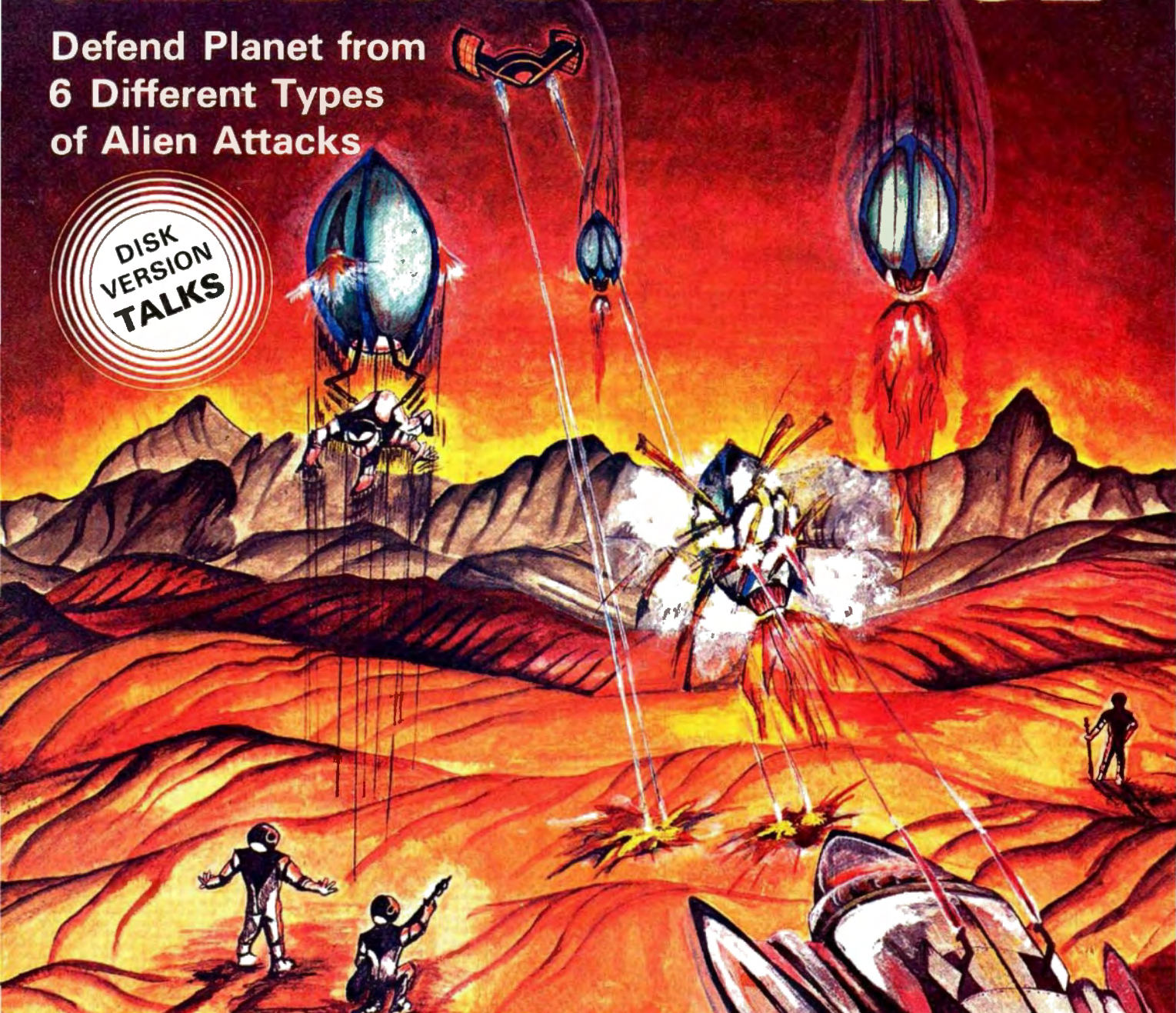

SSM SOFT SECTOR MARKETING,
INCORPORATED

6250 Middlebelt • Garden City, Michigan 48135
800-521-6504 / (313) 425-4020

Written by Larry Ashmun, Copyright ©1981 Soft Sector Marketing, Inc.

Prices Per Game: TRS-80 16K Level II Mod I/Mod III Cassette \$15.95
TRIS-80 32K Level II Mod I/Mod III Diskette \$19.95

Talking and sound effects are playable through the cassette AUX plug. High scores are automatically saved after each game on disk versions.

Call or write for our complete catalog.

10% discount for 2 items, 15% for 3 or more. Please add \$2.50 per order for postage & handling. Michigan residents add 4% sales tax. Outside USA (except Canada) please add \$10.00 per order for postage & handling.

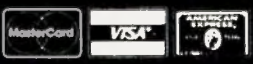

"A special feature of the music board is its unique hardware metronome."

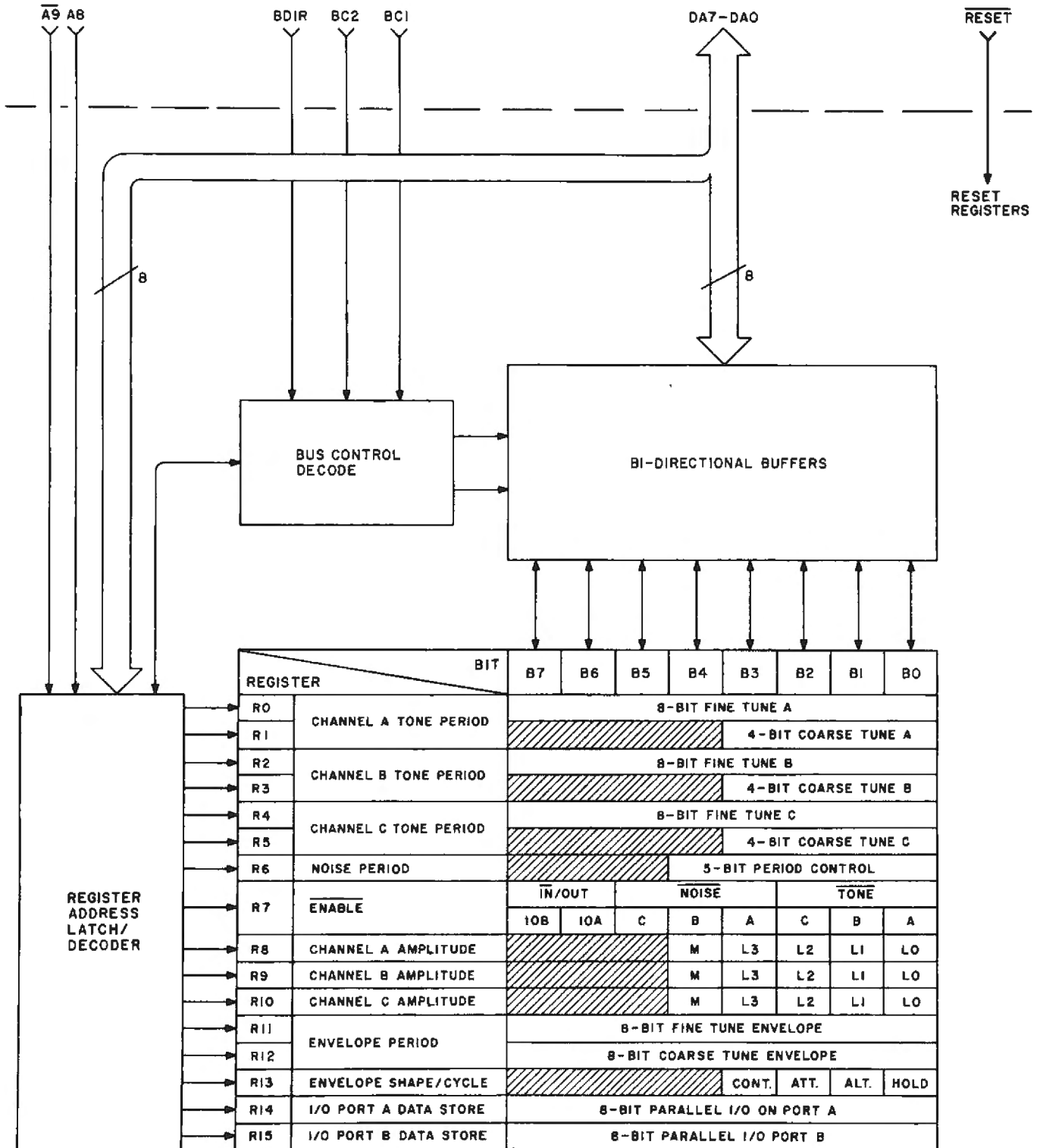

Fig. 1. Internal registers of PSGs. All register numbers in decimal.

GALAXY OF FEATURES

A **GALAXY** of features makes the **LNW80** a remarkable computer. As you explore the **LNW80**, you will find the most complete, powerful, ready to run, feature-packed personal and business computer ever made into one compact solid unit.



MODEL I COMPATIBILITY - The **LNW80** is fully hardware and software compatible with the Model I. Select from a universe of hardware accessories and software - from VisiCalc® to space games, your **LNW80** will launch you into a new world of computing.

FULLY LOADED - A full payload includes an on-board single and double density disk controller for 5 1/4" and 8" single or double sided disk drives. RS232C communications port, cassette and parallel printer interfaces are standard features and ready to go. All memory is fully installed - 48K RAM, 16K graphics RAM and 12K ROM complete with Microsoft **BASIC**.

QUALITY CONSTRUCTION - Instrumentation quality construction sets **LNW80** computers apart from all the rest. Integrated into the sleek solid steel case of the **LNW80** is a professional 74-key expanded keyboard that includes a twelve key numeric keypad.

HIGH RESOLUTION GRAPHICS & COLOR - The stunning 480 X 192 resolution gives you total display control - in color or black and white. The choice of display formats is yours; 80, 64, 40 and 32 columns by 24 or 16 lines in any combination of eight colors.

PERFORMANCE - Lift-off with a 4MHz Z80A CPU for twice the performance. The **LNW80** outperforms all computers in its class.



Our down to earth price won't send you into orbit

LNW Research Corp.

2620 WALNUT Tustin, CA. 92680
(714) 641-8850 (714) 544-5744

Monitor and Disk drives not included
TM Personal Software, Inc.

"Before any sounds can be produced you must enter certain presets."

all values of data in the PSG to zero. The actual value output by the computer via OUT 4 does not matter.

A special feature of the music board is its unique hardware metronome. Inclusion of a hardware metronome simplifies the software necessary for encoding music. The metronome has an adjustable trimpot for manually presetting the metronome rate. A flashing LED gives a visual indication of quarter notes, or metronome beats. Actual note duration is software selected and encoded in the least significant three bits of the control word, as Fig. 3 shows. For entering a musical score, you can use the metronome in several ways:

- To count time in the shortest units needed for a particular musical selection, for example 64th notes, with the software keeping a tally of notes.

- With certain limitations, the metronome can count all the note durations, and you need encode only simultaneous notes in terms of the smallest note durations.

You can bypass the metronome altogether if the software never tests the value of IN 0, or temporarily if software decodes 000 not as 128th notes but as Static or no advance of the metronome—governed by last note duration. This gives simultaneous notes or chords, wherein only the first of several simultaneous notes is encoded with the (shortest necessary) note duration, and the remaining notes have a 000 code. Bypassing the metronome is also useful for inputting initial PSG specs—presetting the PSGs—at the beginning of a musical selection.

If you use the metronome to keep track of all notes, a slight complication occurs whenever different PSGs are selected for the two or more simultaneous notes. Software must keep track of the current note duration for the first note and re-output the control word for subsequent Static notes, using saved current note duration (but different PSG select) instead of the 000 code. In other words, the 000 code is never output to the metronome; software always appends the current note duration code to all simultaneous notes.

Circuit Description

Figure 4 shows the schematic of the music board. The clock circuitry is from the PSG Data Manual. It contains a popular color burst crystal in a standard tank circuit. The crystal's fundamental frequency is divided by two by Z2A, a 74LS74 flip-flop. The resultant frequency of 1.7897725 MHz is supplied to each PSG, where it is divided down to produce tones and noise, and to

Program Listing 2 Continued

```

                                00290          ; = A(0,0) FROM BASIC
                                00300          ; OR RNDM PROGRAM
                                00310          ;
E000 D304          00320          OUT      (4),A          ;RESET PSG'S
E002 3E07          00330          LD        A,7          ;INITIALIZE CND WITH A
E004 32F0DF        00340          LD        (CND),A          ; WHOLE NOTE
E007 DD2AF6DF      00350          LD        IX,(KLSB)        ;ADDRESS OF A(0,0)
E00B DD4E00        00360          LD        C,(IX)          ;ACTUAL NUMBER OF NOTES
E00E DD4601        00370          LD        B,(IX+1)        ; = A(0,0)
E011 ED43PEDF      00380          LD        (NOTES),BC       ;SAVE IN DATA TABLE
E015 D06EPE        00390          LD        L,(IX-2)        ;DEPTH OF 1ST ARRAY DIM.
E018 D066PF        00400          LD        H,(IX-1)        ; FROM X-2 OF VARPTR
E01B 29           00410          ADD      HL,HL          ;CALCULATE K2
E01C E5           00420          PUSH     HL
E01D D1           00430          POP      DE
E01E DD19          00440          ADD      IX,DE          ;IX STILL CONTAINS (KLSB)
E020 DD22PADF      00450          LD        (K2),IX        ;SAVE IN DATA TABLE
E024 29           00460          ADD      HL,HL          ;CALCULATE K4
E025 E5           00470          PUSH     HL
E026 D1           00480          POP      DE
E027 DD2AF6DF      00490          LD        IX,(KLSB)        ;ADDRESS OF A(0,0)
E02B DD19          00500          ADD      IX,DE
E02D DD22PCDF      00510          LD        (K4),IX        ;SAVE IN DATA TABLE
E031 010200        00520          LD        BC,2          ;INITIAL VALUE FOR LOOP
                                00530          ;BC=ARRAY INDEX TIMES TWO
                                00540          ; IF INITIAL PRESETS ARE STATIC (000 CODE FOR THE METRONOME)
                                00550          ; THEN WHOLE NOTE IN (CND) IS APPENDED TO EACH CONTROL WORD
E034 2AF6DF        00560          LD        HL,(KLSB)        ;CALCULATE ARRAY POINTER
E037 09           00570          ADD      HL,BC
E038 7E           00580          LD        A,(HL)          ;POINT TO A(N,0)
E039 32EFDf        00590          LD        (CWORD),A        ;ENTER INTO TABLE
E03C E607          00600          AND      7              ;TEST FOR STATIC
E03E 280C          00610          JR        Z,STATIC        ; 000 IN BITS 0, 1 AND 2
E040 32F0DF        00620          LD        (CND),A          ;SAVE CURRENT NOTE DURAT.
                                00630          ; THE WAIT LOOP HOLDS BACK NEW NOTE UNTILL PREVIOUS NOTE HAS EXPIRED.
E043 DB00          00640          INLOOP  IN      A,(0)        ;HARDWARE INPUT LOOP
E045 FEFF          00650          CP        0FFH
E047 28FA          00660          JR        Z,INLOOP        ; LOOP IF NOT READY
E049 7E           00670          LD        A,(HL)
E04A 1804          00680          JR        OUTPUT          ;RELOAD A(N,0)
E04C 3AF0DF        00690          STATIC LD      A,(CND)        ;LOOK UP CURRENT NOTE DUR.
E04F 86           00700          ADD      A,(HL)          ;APPEND IT TO STATIC
E050 D300          00710          OUTPUT  OUT     (0),A        ;OUTPUT CONTROL WORD
                                00720          ; THE HARDWARE METRONOME IS BEING REPEATEDLY LOADED WITH
                                00730          ; CURRENT NOTE DURATION FOR STATIC (SIMULTANEOUS) NOTES
                                00740          ;
                                00750          ; CALCULATE ARRAY INDEX FOR PSG ADDRESS SPECIFICATIONS
E052 2AFADF        00760          LD        HL,(K2)          ;FROM DATA TABLE
E055 09           00770          ADD      HL,BC          ;POINT TO A(N,1)
E056 7E           00780          LD        A,(HL)          ; = A(N,1)
E057 FE01          00790          CP        1              ;TEST FOR DOUBLE
E059 2826          00800          JR        Z,DOUBLE        ; PSG REGISTERS
E05B FE03          00810          CP        3
E05D 2822          00820          JR        Z,DOUBLE
E05F FE05          00830          CP        5
E061 281E          00840          JR        Z,DOUBLE
E063 FE0D          00850          ; TEST FOR PSG REG. 13, ENVELOPE SHAPE/CYCLE
E065 2836          00860          CP        13             ;PSG REG. 13?
                                00870          JR        Z,ESC          ;FOR FURTHER PROCESSING
                                00880          ;
E067 D301          00890          OUT      (1),A          ;OUTPUT ADDRESS FOR ANY
                                00900          ; OTHER SINGLE PSG REG.
E069 FE06          00910          ; TEST WHETHER JUST ADDRESSED PSG REG. 6, NOISE PERIOD,
                                00920          ; WHICH MUST TRIGGER ENVELOPE SHAPE/CYCLE AUTOMATICALLY
                                00930          CP        6
E069 FE06          00940          ; CALCULATE POINTER TO ARRAY MEMBER CONTAINING PSG DATA

```

Program Listing 2 Continues

		D7	D6	D5	D4	D3	D2	D1	D0
OUT 0	Control Word.	L	R	X	X	C	note duration		
	A 1 selects, a 0 deselects a left, right or center PGS.								
	X = does not matter (reserved for left-center and right-center PSG).								
IN 0	Status of Hardware Metronome.								
	Previous note still active:	1	1	1	1	1	1	1	1
	Previous note has ended:	1	1	1	1	1	1	1	0
OUT 1	Address Latch for selected PSGs.								
	PSG register 0:	0	0	0	0	0	0	0	0
	through register 13:	0	0	0	0	1	1	0	1
OUT 2	Data Latch for PSGs.								
		Data range: 0-255, as required.							
OUT 4	Reset all PSGs. Sets all values of data to zero.								
	The actual value output via OUT 4 does not matter.								

Fig. 2. Input/output port assignment

"In line 13, three simultaneous notes can be triggered . . ."

advance envelopes.

Z6, Z7 and Z8 decode the address bus for port mapping. Z3 and Z4 gate the microprocessor IN and OUT signals to give the port assignment listed in Fig. 2. The microprocessor data bus is connected to each PSG as well as to Z9, a 74LS374 Latch. Z9 stores the control word that enables PSGs and latches a request onto the metronome.

The hardware metronome relies on Z13, a 555 timer, to provide the clock. A manual trimpot for adjusting metronome beats is connected to Z13. Timer output goes to two cascaded binary counters, Z11 and Z12. The eight binary outputs are applied to Z10, a 74LS151 One-of-eight Data Selector. A three bit code latched to the address inputs of Z10 will select one of the eight counter lines. The selected line will appear at pin 6 of Z10, for analysis by edge detector circuitry utilizing a CMOS 4070 Exclusive-Or gate, Z5.

A change of state, that is either a positive or negative transition, indicates the end of a particular note. The edge detector converts this transition to a short positive-going pulse which is applied to Z2b, a 74LS74 flip-flop that is armed by an OUT 0 command. Once armed, additional OUT 0 signals have no effect, and the flip-flop output stays positive until it receives the edge detector pulse. Thereupon the output goes low, permitting gate Z4 to output a high level signal to transistor Q1 if an IN 0 signal is received, as during the software wait loop. The 2N3904 npn transistor Q1 is wired in an open-collector configuration; a high level applied to its base will give a true low at microprocessor data bit D0, whereas a low level on its base will give a high-impedance output that does not affect the data bus. In response to an IN 0 command, the data will yield 254 if D0 is at logic level low, and 255 if D0 is at high impedance.

The LED is connected to the counter line for eighth notes. This gives a short flash every quarter note.

The nine-voice PSG music board draws

D2	D1	D0	
1	1	1	= Whole note
1	1	0	= Half note
1	0	1	= Quarter note
1	0	0	= Eighth note
0	1	1	= 16th note
0	1	0	= 32nd note
0	0	1	= 64th note
0	0	0	= 128th note (or Static—no advance)

Fig. 3. Metronome codes

about 250 mA at 5 VDC. This can be conveniently obtained from an AC Adaptor such as the Radio Shack Cat. No. 270-1551, 300 mA at 9 VDC, plugged into the voltage regulating circuit shown on the schematic of Fig. 4. If you expand the music board to 15 voices, or five PSGs, the power supply will have to be larger because each PSG chip draws 45-75 mA. Expanding the music board to 15 voices is straightforward; it involves connecting the unused outputs of Z9 to A8 of each PSG: D4 for right-center and D5 for left-center PSG, and employing a five to two stereo mixer such as that shown in Fig. 5. Encoding of 15 voices will require more RAM. A 48K TRS-80 will accommodate a 5-10 minute multi-part musical score, played at average tempo.

The parts list is given in Fig. 6. The finished nine-voice PSG music board is shown in Photo 1, wire wrapped on a Vector board.

Metronome Limitations

If you use the metronome to count only the shortest time intervals necessary for a particular selection, say 64th notes, the considerations below do not apply. However, if you use the metronome to count all the notes of a selection, some limitations apply: you must break certain sequences of notes down into proper elements to assure correct counting.

Fig. 7 is a partial timing diagram showing how the different note-duration outputs are available from the metronome simultaneously. The diagram applies to the 74LS93 binary counters used in the metronome's construction. The metronome always counts between transitions, either positive or negative. For example, if you start on the plateau of a quarter note followed by an eighth note, time proceeds along the

quarter note plateau until the first transition is encountered; then the metronome jumps to the output labeled eighth note and proceeds along this plateau until the next transition. For any transition, the IN 0 value will not be equal to 255, so that software can load the next series of specifications.

Certain note sequences must be programmed in time units that the metronome can handle without error. Fig. 8 shows two examples. In general, if a short, syncopated note precedes a longer note, you must break up the longer note into shorter tied notes. In actual programming this rarely occurs; moreover, the reverse—longer note followed by much shorter notes—gives no problem.

You should synchronize the metronome with the longest note possible, by outputting a whole note rest before the musical selection begins. This will assure that all note outputs are initially at a low logic level, and that the metronome will begin counting on the downbeat.

Testing and Programming

After performing continuity tests and inserting the ICs, you can obtain some sounds from the music board. The easiest approach is to enter from the keyboard a series of OUT 0, OUT 1 and OUT 2 statements for the control word, PSG register address and PSG data respectively, as shown in the example of Fig. 9. Before any sounds can be produced, you must enter certain presets, such as those in lines 1-3. After a note is specified, as in lines 4 and 5, the envelope must be triggered by addressing PSG register 13, envelope shape/cycle. Since line 3 selected envelope control, a note will not be struck unless PSG register

COLOR COMPUTER USERS . . . YOUR EXCLUSIVE MONTHLY MAGAZINE



the RAINBOW

HAS A POT OF GOLD FULL OF

- Programs
- Hints and Tips
- Helpful Utilities
- Honest Reviews
- New User Tutorials
- Software Discounts

The RAINBOW is devoted only to the TRS-80[®] COLOR COMPUTER! It is the magazine that will help you get the most out of your Color Computer whether you're interested in fun and games, business applications or education.

"The RAINBOW is a pot of gold full of fabulous information!" —P. M., Detroit

"I wouldn't be without the RAINBOW. It's the best!"

—R. P., Seattle

the RAINBOW

5803 Timber Ridge Dr. • Prospect, KY 40059

Subscribe to the RAINBOW today.

A 12-month subscription is only \$16.

Canadian points please add \$2.50

All subscriptions start with current issue. Limited back issues available for \$2. plus \$2.50 postage and handling.

®Trademark of Tandy Corp.

296

“These specifications are sufficient to encode a multi-part score. . .”

13 is addressed. In line 13, three simultaneous notes can be triggered this way.

The simple example above makes no use of the metronome, since no software was

employed to analyze the metronome code or to sample IN 0, the metronome status port. Shortly, I will discuss a PLAYBK driver which will accept a three-dimensional array

similar to the one shown on Fig. 9, but with several simplifications. The following points summarize the requirements for a three-dimensional integer array $A\%(X,2)$:

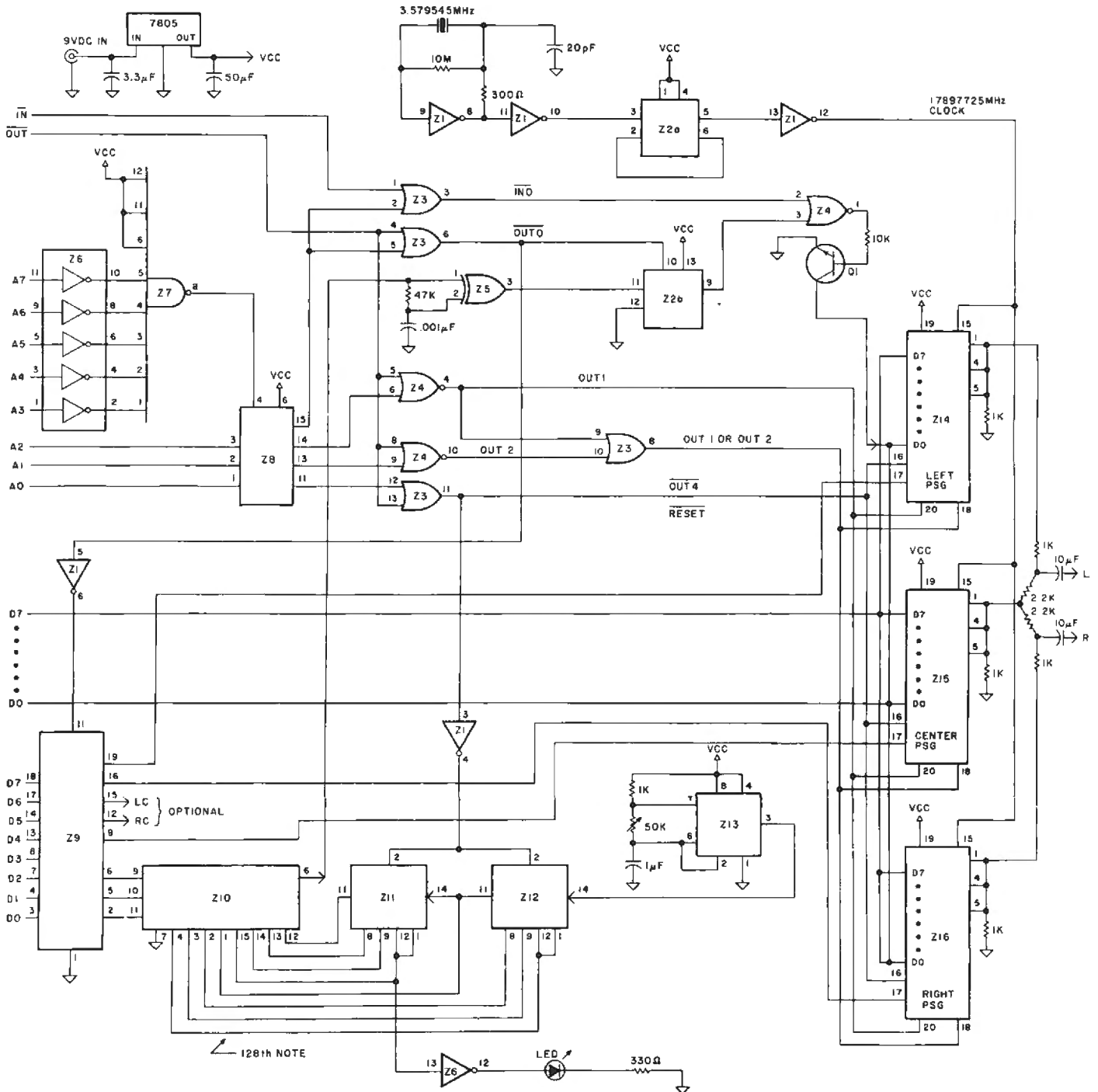
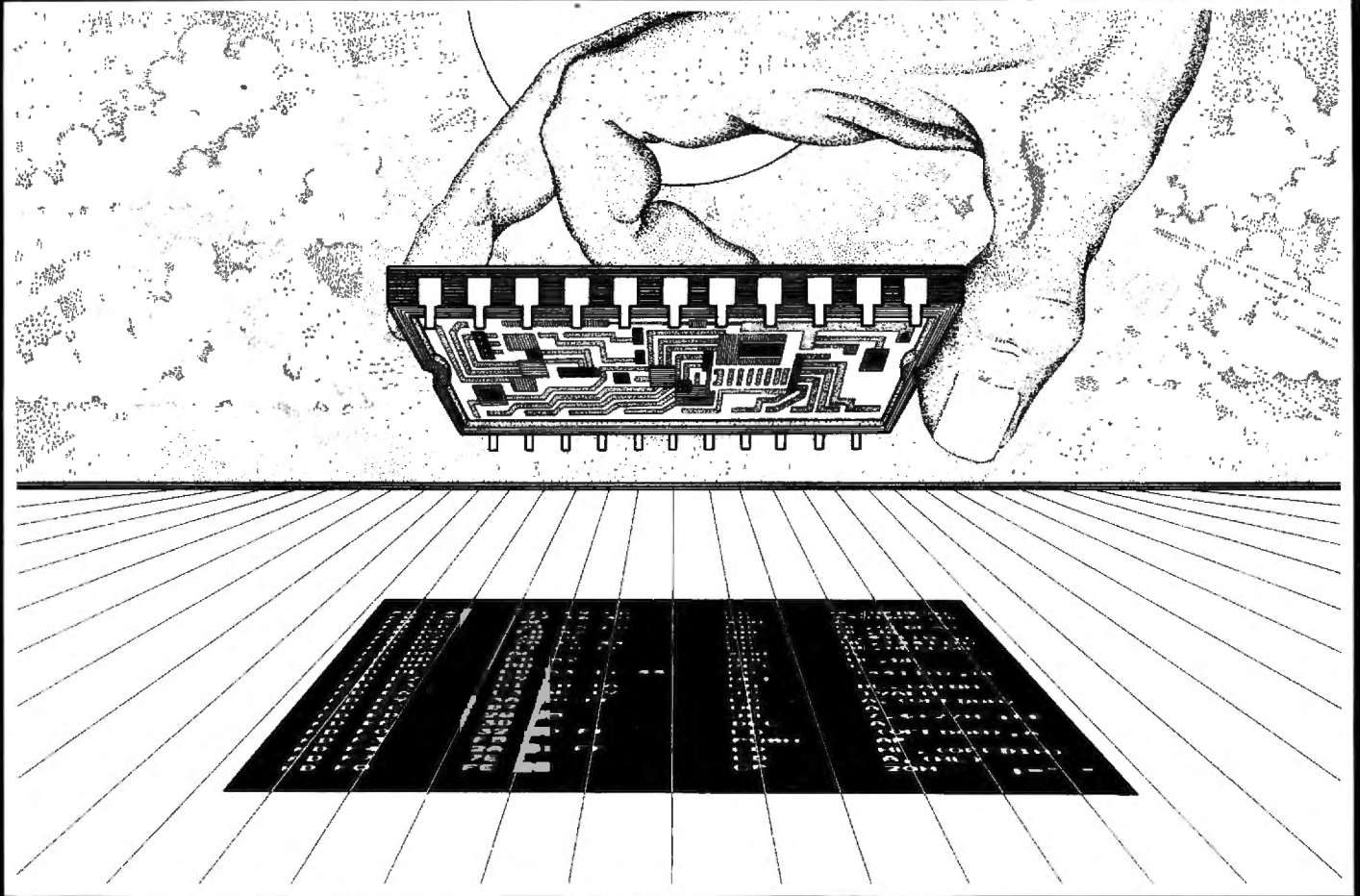

Fig. 4. PSG music board schematic

MACRO-MONITOR ...THE SHADOW



What secrets lurk deep within the heart of your microprocessor? Only THE SHADOW knows. Advanced Operating Systems shines the light on the intricate workings of your *TRS-80 Model I or Model III microcomputer. MACRO-MONITOR, THE SHADOW, is a machine language program by Jake Commander which allows you to disassemble and examine program instructions from any part of your computer's memory. THE SHADOW even enables you to single-step through your computer's ROM.

With THE SHADOW, you can load a machine language program from disk or tape and

begin execution at a user-specified breakpoint, one instruction at a time, with a user-defined time delay between instructions. It will disassemble each instruction as it is being executed and route it along with all current register values to your video screen or printer. The user may also search through memory for a specific character string (ASCII or Hex) up to 16 bytes in length.

THE SHADOW permits machine language programs to be relocated within memory with all internal calls and jumps changed to execute in the new location. The program also provides a visual display of tape LOADS and SAVES.

THE SHADOW is completely user-relocatable in RAM making it an extremely valuable tool for all programmers.

Now available at your local software retailer, or call (800) 348-8558 to order. (Indiana residents, call (219) 879-4693) MasterCard and VISA accepted.

MODEL I TAPE	\$54.95
MODEL I DISK	\$59.95
MODEL III DISK	\$69.95

ADVANCED OPERATING SYSTEMS

450 St. John Road
Michigan City, IN 46360

✓ 280

"Only the shortest time intervals are encoded explicitly. . ."

- The three dimensions are assigned as follows: A%(N,0) = control word; A%(N,1) = PSG register address; and A%(N,2) = PSG data.

- A%(0,0) contains the number of notes to be played. A%(0,1) and A%(0,2) are unnecessary although they may be used for identification.

- The PLAYBK driver automatically performs double loads to the tone-generat-

ing PSG registers. Only the MSB registers 1, 3 or 5 need to be addressed via A%(N,1); the corresponding A%(N,2) should contain the entire code for the desired note frequency.

- The driver automatically triggers PSG register 13, envelope shape/cycle, whenever a note is to be output (registers 1, 3 or 5) or whenever PSG register 6, noise period, is loaded.

- The driver does not execute any data sent to PSG register 13, envelope shape/cycle, but stores them in a lookup table. The most current values in the table trigger notes and noise automatically.

- You enter the score from left to right, in a "parallel" fashion, similar to the way a keyboardist would play a score.

- The first of simultaneous notes requires a metronome code that reflects the *shortest* of the simultaneous notes. The other notes, including the shortest ones, use 000 for the code. Thus only the shortest time intervals are encoded explicitly; the longer notes will sustain automatically until reloaded.

- You can obtain tied notes by temporarily outputting an appropriately different envelope period, and reloading the usual envelope period afterwards.

- You can obtain rests by turning off a particular channel: temporarily load its amplitude register with 0000, and then reload it with the usual value afterwards.

These specifications are sufficient to encode a complicated multi-part score, but it is a time consuming task for anything but short selections.

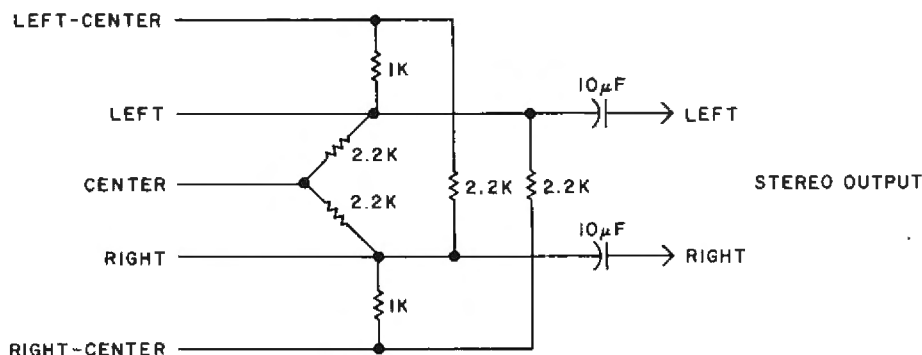

Fig. 5. Stereo mixer for a 15-voice PSG music board

IC	Type	Vcc	GND
Z1	4069UB	14	7
Z2	74LS74	14	7
Z3	74LS32	14	7
Z4	74LS02	14	7
Z5	4070B	14	7
Z6	74LS04	14	7
Z7	74LS30	14	7
Z8	74LS138	14	7
Z9	74LS374	10	20
Z10	74LS151	16	8
Z11, Z12	74LS93	14	7
Z13	555	8	4
Z14, Z15, Z16	AY-3-8912	3	6

Source	Device
1	VECTOR 51X1PDP Mounting frame
1	VECTOR 3677-6DP DIP Padboard
1	APP-924150-24 Interface cable
1	APP-929636-05 Male header, straight, WW
1	RS 272-1310 Color burst crystal, 3.579545 MHz
1	2N3904 transistor
1	7805 voltage regulator
1	RS 271-219 50K one-turn trimpot
1	LED with mount
6	Resistors, 1k 1/4W
2	Resistors, 2.2k
1 each	Resistors: 300 ohm, 330 ohm, 10k, 47k, 10M
1 each	Ceramic caps: 20pF, .001µF, .1µF
3 or more	Decoupling caps, 0.1 or 0.22 µF
1 each	Tantalum caps: 1µF, 3.3µF
2	Tantalum caps, 10µF
1	Electrolytic cap, 50µF/25V
1	RS 274-332 Audio jacks, dual
1	RS 270-1551 Power supply, 9V at 300 mA
1	Switchcraft 722A Power supply jack (small pin)

Fig. 6. Parts list for nine-voice PSG music board

Software

Program Listing 1 shows a short Basic calling program and two machine-language drivers, PLAYBK and RNDM, encoded in Data statements. The Basic program transmits two variables to the USR subroutines: a flag to prevent reinitializing certain values, and VARPTR of A%(0,0), the first member of the three-dimensional integer array containing the notes. The PLAYBK driver also needs the value of A%(0,0), the actual number of notes, so it is defined in line 840 of Listing 1. Initializing certain variables in line 70 prevents the array from being dynamically relocated by the Basic interpreter after the first loop through the program, and may be omitted.

Program Listing 2 is an EDTASM source file for the PLAYBK driver. It accepts the three-dimensional array from Basic and sends the proper sequence of PSG addresses and data to the output ports, as well as reads the metronome status via an input port, as specified in Fig. 2.

At top of PLAYBK is a data table with 12 entries. Five of these are envelope shape/cycle specifications for PSG register 13. These are output automatically after notes or noise, because they trigger the envelopes. Data table entries K2, K4 and Notes are calculated array parameters. Program lines 350-510 perform these calculations.

MX-80/100 OWNERS

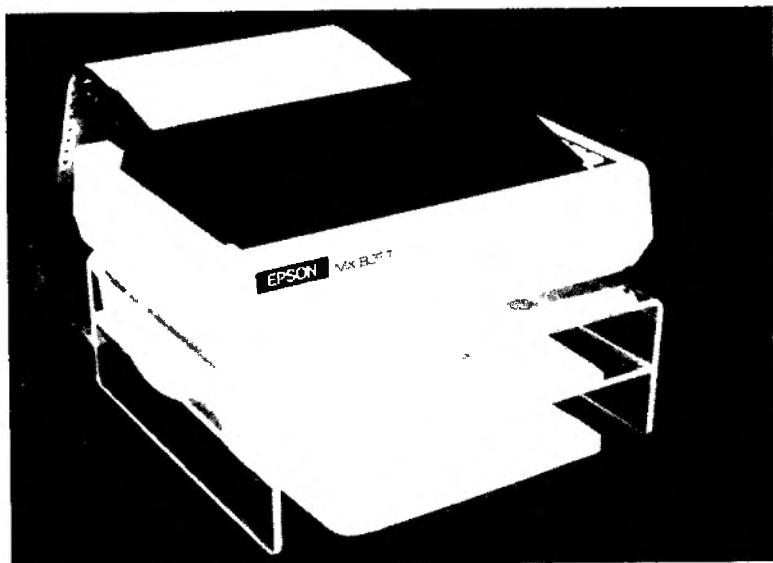

PRINTER STANDS

End the mess of paper from your desktop printer. Paper is fed from under the printer and allowed to stack neatly behind your machine. Made from the highest quality clear plexiglass, this is a handsome addition to home or office. Available in two sizes - Regular for printers such as MX-80, Microline80, etc. or Large for printers such as MX-100, DataRoyal, DWII etc. Available with extra shelf for quick and easy forms change.

Regular (300010)	29.95
Regular w/shelf (300011)	44.95
Large (300020)	34.95
Large w/shelf (300021)	49.95

MX-80 RELOADS

Reload your own MX-80 & MX-100 Ribbon Cartridges, and save money. These endless loop Silver Dollar Ribbon packs load into your worn cartridge easily, saving you money. Now available in **Blue** and **Red**.

Black (500000)	\$3.95 ea.	Black (500001)	\$39.50 doz.
Red (500010)	4.95 ea.	Red (500011)	49.95 doz.
Blue (500020)	4.95 ea.	Blue (500021)	49.95 doz.

MX-80 RIBBON CARTRIDGE

Same as original cartridge, with the additional feature of "Mobis" loop which turns the ribbon 180° after each run through the cartridge extending ribbon life. As you know MX-80 cartridges cost \$15.00 from most sources, but these are only \$10.95 each or save even more by buying 3 at \$29.95.

1 cartridge (500050)	\$10.95	2 pack (500051)	\$29.95
----------------------------	----------------	-----------------------	----------------

NEW — We now carry the **DIGIAC MULTIUSER COMPUTER**. Call for details on **MULTIUSER Processing!!**



171 Hawkins Road
Centereach, New York 11720

(516) 981-8568 (Voice)
(516) 588-5836 (Data)
MNET-70331, 105



Dealer Inquiries Welcome

Add \$2.00 S & H
NYS res. add appr. tax ✓300

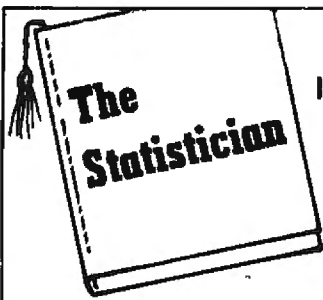

First in
Its Class
and
Looking
for
Work.

TRS-80 Model I, II, III

Five multiple regression procedures (including stepwise, backward elimination, all subset, and ridge), 24 transformations, comprehensive data base manager (with search and sort), descriptive statistics, hypothesis testing (7 tests), time series analysis (7 models), random variate generation, discrete probability distributions, sampling distributions, nonparametrics (5 tests), and complete documentation.

Complete package with manual — \$125
To order, send payment plus \$2.00 shipping and handling to:

Quant Systems

P.O. Box 628

Charleston, S.C. 29402

803-571-2825

✓194

S.C. residents add 4% sales tax
Overseas orders add \$7 for shipping

**EPSON MX-80
COMPLETE
PRINTER PACKAGE
SAVE \$270⁰⁰**

- EPSON MX-80
- GRAFTRAX-80
- EXTRA MX-80 RIBBON
- 5000 MAILING LABELS
- 3200/2600 SHEETS (1 Case) TRACTOR FEED PAPER
- LISTER/CMD (Disk Model I & III Only)

APPROXIMATE VALUE \$839.⁸⁵

You Pay Only \$569.⁸⁵

Rainbow

P & P CORPORATION

✓265

P.O. Box 362 • HADDONFIELD, N.J. 08033

TOLL FREE ORDERS ONLY **800-257-6170**
in New Jersey 609-428-3900

Enclosed is my check for \$569.⁸⁵
plus \$11.90 for shipping and handling

MX-80 Complete Printer Package

Visa Master Card Check
C.O.D. Wire Transfer (less 2%)

Credit Card No _____ Exp Date _____

Name _____

Address _____

City _____ State _____ Zip _____

Phone (_____) _____

* New Jersey Residents add 5% Sales Tax

"The wait loop prevents the output until the metronome status indicates that previous note has ended."

Program Listing 2 Continued

```

E06B 2AFCDP 00950 LD HL,(K4) ;FROM DATA TABLE
E06E 09 00960 ADD HL,BC ;POINT TO A(N,2)
E06F 7E 00970 LD A,(HL) ;= A(N,2)
E070 D302 00980 OUT (2),A ;OUTPUT PSG DATA
E072 CCD1E0 00990 CALL Z,TRIGG ;FROM CP 6 INSTRUCTION
; CONTINUE PROCESSING ARRAY IF NOT AT END
E075 03 01010 CONT INC BC ;ADVANCE ARRAY POINTER
E076 03 01020 INC BC ; BY TWO (INTEGER ARRAY)
E077 2AFEDF 01030 LD HL,(NOTES) ;NUMBER OF NOTES
E07A 29 01040 ADD HL,HL ;DOUBLE IT
E07B AF 01050 XOR A ;CLEAR CARRY
E07C ED42 01060 SBC HL,BC ;END OF ARRAY?
E07E 2B44 01070 JR NZ,LOOP
E080 C9 01080 RETURN RET ;BACK TO BASIC
; A CONTAINS PSG REGISTER NUMBER 1,3, OR 5
E081 D301 01100 DOUBLE OUT (1),A ;=A(N,1) OUTPUT PSG REG. NO.
E083 5F 01110 LD E,A ;SAVE A IN E FOR DECREMENT.
E084 DD2AFCDP 01120 LD IX,(K4) ;FROM DATA TABLE
E088 DD09 01130 ADD IX,BC ;BC=ARRAY POINTER
E08A DD7E01 01140 LD A,(IX+1) ;= A(N,2), MSB DATA
E08D D302 01150 OUT (2),A ;OUTPUT MSB DATA
E08F 1D 01160 DEC E ;POINT TO LSB REG. NO.
E090 7B 01170 LD A,E ;A=PSG REG. NO. 0, 2 OR 4
E091 D301 01180 OUT (1),A ;OUTPUT PSG REGISTER NO.
E093 DD7E00 01190 LD A,(IX) ;= A(N,2), LSB DATA
E096 D302 01200 OUT (2),A ;OUTPUT LSB DATA
E098 CDD1E0 01210 CALL TRIGG ;TRIGGER ENVELOPE
E09B 1BD8 01220 JR CONT ;CONTINUE
;
; ROUTINE TO ENTER ENVELOPE SHAPE/CYCLE INTO TABLE
; FOR SUBSEQUENT AUTOMATIC OUTPUT WITH NOISE OR TONES
E09D 3AEFDF 01260 ESC LD A,(CWORD) ;CURRENT CONTROL WORD
E0A0 5F 01270 LD E,A ;INTO E
E0A1 2AFCDP 01280 LD HL,(K4) ;CALCULATE A(N,2)=DATA
E0A4 09 01290 ADD HL,BC
E0A5 7E 01300 LD A,(HL) ;= A(N,2)
E0A6 PD21F1DF 01310 LD IX,LENV ;POINT TO TOP OF TABLE
E0AA CB7B 01320 BIT 7,E ;TEST WHETHER LEFT PSG
; WAS SELECTED
E0AC CDC6E0 01340 CALL FILL ;UPDATE TABLE IF NECESS.
E0AF CB73 01350 BIT 6,E ;RIGHT PSG SELECTED?
E0B1 CDC6E0 01360 CALL FILL ;LEFT-CENTER?
E0B4 CB6B 01370 BIT 5,E ;RIGHT-CENTER?
E0B6 CDC6E0 01380 CALL FILL ;CENTER PSG?
E0B9 CB63 01390 BIT 4,E ;BACK TO LOOP
E0BB CDC6E0 01400 CALL FILL ;JP IF BIT SET
E0BE CB5B 01410 BIT 3,E ;TABLE POINTER
E0C0 CDC6E0 01420 CALL FILL ;TO ROUTINE
E0C3 C375E0 01430 JP CONT ;UPDATE TABLE ENTRY
;
; SUBROUTINE TO TRIGGER ENVELOPES USING TABLE ENTRIES
; PROPER ENVELOPE SHAPE/CYCLE IS OUTPUT TO EACH PSG
E0D1 PD21F1DF 01540 TRIGG LD IX,LENV ;POINT TO TOP OF TABLE
E0D5 3AEFDF 01550 LD A,(CWORD) ;CURRENT CONTROL WORD
E0D8 5F 01560 LD E,A ;INTO E
E0D9 CB7B 01570 BIT 7,E ;LEFT PSG SELECTED?
E0DB 1600 01580 LD D,80H ;= 10000000
E0DD CDFDE0 01590 CALL EXAM ;EXAMINE IT
E0E0 CB73 01600 BIT 6,E ;RIGHT PSG?
E0E2 1640 01610 LD D,40H ;= 01000000
E0E4 CDFDE0 01620 CALL EXAM ;LEFT-CENTER PSG?
E0E7 CB6B 01630 BIT 5,E ;= 00100000
E0E9 1620 01640 LD D,20H ;RIGHT-CENTER PSG?
E0EB CDFDE0 01650 CALL EXAM ;= 00010000
E0EE CB73 01660 BIT 4,E ;CENTER PSG?
E0F0 1610 01670 LD D,10H ;= 00001000
E0F2 CDFDE0 01680 CALL EXAM ;TO CALLING PROGRAM
E0F5 CB5B 01690 BIT 3,E
E0F7 1600 01700 LD D,0 ;IF BIT SET
E0F9 CDFDE0 01710 CALL EXAM ;ADVANCE TABLE POINTER
E0FC C9 01720 RET ;TO SUBROUTINE
; MUST APPEND CND TO ANY CONTROL WORD FOR THE METRONOME
E0FD 2003 01740 EXAM JR NZ,HIGH ;FROM TABLE
E0FF FD23 01750 INC IX ;APPEND CND TO SINGLE
E101 C9 01760 RET ; PSG SELECT IN D
E102 3AF8DF 01770 HIGH LD A,(CND) ;OUTPUT CONTROL WORD
E105 82 01790 ADD A,D ; FOR SINGLE PSG
; PSG REG. 13
E106 D300 01810 OUT (0),A ;ADDRESS IT
E108 3E0D 01830 LD A,13 ;GET PROPER ENV. SHAPE
E10A D301 01840 OUT (1),A ;OUTPUT IT AS DATA TO PSG
E10C PD7E00 01850 LD A,(IX) ;POINT TO NEXT TABLE ENTRY
E10F D302 01860 OUT (2),A ;TO SUBROUTINE
E111 FD23 01870 INC IX
E113 C9 01880 RET
0000 01890 END
00000 TOTAL ERRORS

```

"The random number generator may crash if too many values are rejected in a repeating loop."

Current control word is stored under CWORD. The program uses it to enable the proper PSGs, after current note duration (CND), also stored in the table, is appended

to the control word. The CND is the three bit metronome code, as listed in Fig. 3, that is automatically appended for any simultaneous notes that have been encoded using

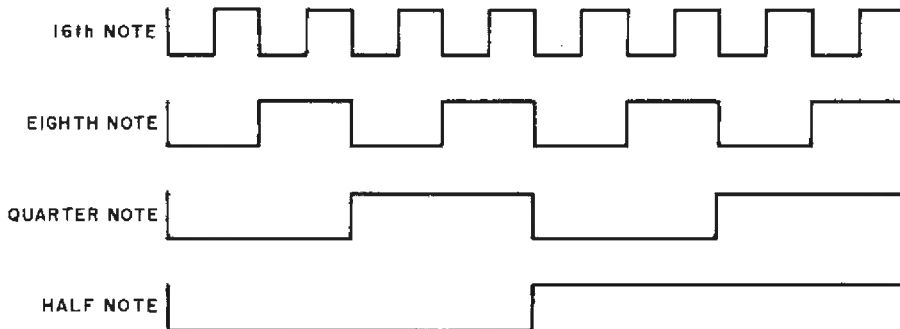

Fig. 7. Timing diagram for metronome based on 74LS93 binary counters. Only four of the eight available outputs are shown.

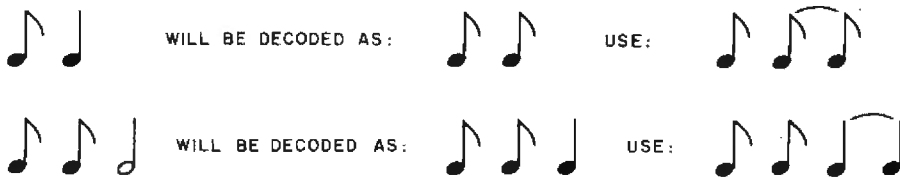

Fig. 8. Examples of note sequences that must be encoded in smaller time units

```

Program Listing 3

00100 ;
00110 ; ** RNDM **
00120 ; ROUTINE TO GENERATE RANDOM SOUNDS WITH DIGITAL MASKING
00130 ; MATT. ROBINS, 6/18/81
E200 00130 ORG 0E200H ;=57856 OR -7688
DFEF 00140 CWORD EQU 0DPEFH ;CONTROL WORD STORAGE
DFPF 00150 KLSB EQU 0DPP6H ;ADDRESS OF A(0,0)
DFPF 00160 FL EQU 0DPP9H ;FLAG=0 FIRST TIME THROUGH
DFFA 00170 K2 EQU 0DPPAH ;ADDRESS OF A(0,1)
DFFC 00180 K4 EQU 0DPPCH ;ADDRESS OF A(0,2)
DFFE 00190 NOTES EQU 0DPPFH ;MAXIMUM NUMBER OF NOTES
00200 ;
E200 D304 00210 OUT (4),A ;RESET PSG'S
E202 3AF9DF 00220 LD A,(FL) ;TEST FLAG = 0
E205 B7 00230 OR A ; IF FIRST TIME THROUGH
E206 203F 00240 JR NZ,BYPASS ;DATA TABLE ALREADY FILLED
00250 ; ENTER INITIAL SEED FOR RANDOM NUMBER GENERATOR
E208 ED5F 00260 LD A,R ;FROM REFRESH REGISTER
E20A FD2133E3 00270 LD IY,RSEED ;POINT TO RSEED
E20E FD7700 00280 LD (IX),A ;LSB
E211 ED5F 00290 LD A,R ;ANOTHER NUMBER
E213 FD7701 00300 LD (IX+1),A ;MSB
00310 ; CALCULATE PARAMETERS FOR TABLE
E216 DD2AF6DF 00320 LD IX,(KLSB) ;ADDRESS OF A(0,0)
E21A DD6EFE 00330 LD L,(IX-2) ;GET DEPTH OF 1ST DIMENSION
E21D DD66FF 00340 LD H,(IX-1) ; PROM K-2 OF VARPTR
E220 E5 00350 PUSH HL
E221 C1 00360 POP BC
E222 08 00370 DEC BC ;CALCULATE NO. OF NOTES
00380 ; = ONE LESS THAN DEPTH
00390 ; OF FIRST DIMENSION
E223 ED43FEDF 00400 LD (NOTES),BC ;SAVE IN DATA TABLE
E227 DD7100 00410 LD (IX),C ;LOAD A(0,0) WITH MAX. NOTES
E22A DD7001 00420 LD (IX+1),B ; FOR PLAYBK ROUTINE
E22D 29 00430 ADD HL,HL ;CALCULATE K2
E22E E5 00440 PUSH HL
E22F D1 00450 POP DE
E230 DD2AF6DF 00460 LD IX,(KLSB)
E234 DD19 00470 ADD IX,DE

```

Program Listing 3 Continues

The Captain 80 Book of BASIC ADVENTURES

- EIGHTEEN ADVENTURES:
- Atlantean Odyssey
 - Dog Star
 - Thunder Road
 - Deadly Dungeon
 - Revenge of Balrog
 - The Fortress at Times-End
 - Temple of the Sun
 - Lost Ship
 - Spider Mountain
 - Lost Dutchman's Gold
 - Journey to the Center of the Earth
 - King Tut's Tomb
 - Voyage to Atlantis
 - House of Seven Gables
 - Sorcerer's Castle
 - CIA Adventure
 - Arctic Adventure
 - Adventureland

All these program listings plus an Adventure Generator not available from any other source!

\$19.95*

Although all programs are written for TRS-80 Model I & III, these programs will easily convert to any other machine using Microsoft® BASIC.



Send to :

80 Northwest Publishing
383B South Warner St.
Tacoma, WA 98409
(206) 475-2219

Name _____

Address _____

City _____

State, Zip _____

Visa/ MC _____

Exp. Date _____

*Please add \$2.05 for Shipping and Handling.

"Thus, noise period registers are treated like tone period registers."

Program Listing 3 Continued

```

E236 DD22PADF 00480      LD      (K2),IX      ;SAVE IN DATA TABLE
E23A 29          00490      ADD     HL,HL        ;CALCULATE K4
E23B E5          00500      PUSH   HL
E23C D1          00510      POP    DE
E23D DD2AF6DF 00520      LD     IX,(KLSB)
E241 DD19        00530      ADD     IX,DE
E243 DD22CDF 00540      LD     (K4),IX      ;SAVE IN DATA TABLE
E247 111200     00550      LD     DE,18        ;INITIAL VALUE FOR LOOP
                                ; FOR N=9 (PRESETS)
                                ; FROM BASIC
                                00560
                                00570
                                00580 ;

```

Program Listing 3 Continues

000. Program lines 580-600 test for the presence of the 000 metronome code. If found, lines 690-700 append the CND to the control word and output it in line 710. Thus, the metronome is repeatedly loaded with the note duration given for the first of several simultaneous notes, even though different PSGs receive the simultaneous notes.

If the next note duration is not Static, code 000, the wait loop in lines 640-660 prevents the output until the metronome status indicates that previous note has ended. Once the control word with proper CND is output, the enabled PSGs are ready to receive the next two specifications: PSG address and PSG data, encoded in array members A%(N,1) and A%(N,2) respectively.

Lines 780-840 test for addresses to PSG registers 1, 3 or 5. These registers contain the most significant four bits of tone period, but the corresponding array member for PSG data will contain the entire 12-bit value that has to be separated into LSB-MSB and output to the double PSG tone period registers. A branch to Double accomplishes the double loads. Subroutine Trigg at line 1540 triggers the tones by looking up the most recent envelopes in the data table and then outputting them to PSG register 13 of the proper PSG.

Line 860 tests for an address to PSG register 13, envelope shape/cycle. Any entries to this register are not output immediately, but stored in the data table by a branch to ESC, line 1260. Finally, line 890 outputs any remaining PSG addresses, including registers 0, 2, 4, 6, 7, 8, 9, 10 or 11. If PSG register 6 was output, as tested in line 930, subroutine Trigg is called, because a proper envelope shape has to be output whenever register 6, noise period, is addressed. Thus, noise period registers are treated like tone period registers. Line 980 outputs the actual PSG data, stored in array as A%(N,2), to any selected PSG register except 1, 3, 5, 6 or 13.

Lines 1010-1070 advance array pointers and test whether all notes have been played. If so, line 1080 returns to the Basic calling program.

Program Listing 3 is the random note array generating routine, or RNDM. It creates a three-dimensional integer array. At the top of the listing is a data table that is shared with PLAYBK. First time through, the routine calculates array parameters K2, K4 and Notes. In this case, Notes is the maximum number possible after dimensioning the array in the Basic program. Lines 260-300 enter a seed for the random

What's a SemiDisk?™

The best disk emulator you'll find anywhere. It's a single 512K byte memory board. (1 Megabyte on special order) It operates like a disk, except far faster. Your software is compatible with no modifications.

No strings attached. No need for a special CPU, DMA, I/O, or disk controller. No need to return your operating system disk. No changes to your present hardware.

SemiDisk doesn't interfere with memory space, which is left totally free for the operating system or user programs. If you have an 8080, 8085, or Z80 CPU with CP/M 2.X on S-100, you can use it right now. (Available soon for TRS-80 Model 2 and IBM Personal Computer.)

Unmatched Performance:

- 30 to 300 times faster than 8" floppies
- Much faster than hard disks
- Expandable to 8 Megabytes
- Only 0.6 amps (typ) supply current for 512K (0.9 amps for 1 Megabyte)

SemiDisk is the least expensive disk emulator per byte of storage. At \$1995 for 512K, it's less than a third the cost of the closest competition.

So compare price, performance, hardware requirements, flexibility, storage density, and expandability, and you'll select SemiDisk!

**SemiDisk
Systems**

P.O. Box GG
Beaverton, OR
97075

(503)-
642-3100

TRS-80 trademark of Radio Shack — CP/M Trademark of Digital Research

"Since the PSGs use a logarithmic volume scale, the low volumes are disproportionately quiet."

number generator RAND by reading the Z80 refresh register R.

After the first time through, the entry point to the RNDM program is at line 550. The Z80 register pair DE serves as an array index times two, since an integer array member occupies two bytes of RAM, and is initialized to a value that accommodates the initial settings entered via Data statements in Basic. Eight such presets were entered into the array in Listing 1, lines 1160-1230. The RNDM routine builds the three-dimensional array starting with the array index N=9. In line 610 of Listing 3, a call to RAND produces the first random control word that is immediately entered into the array as A%(9,0). In line 650, a call is made to RAND to obtain a PSG register address. After rejecting non-applicable registers, the random number becomes array member A%(N,1) in line 770.

Logically it would follow that a third call

to RAND would give the PSG data, array member A%(N,2). Unfortunately, such purely random data do not sound pleasant. The rest of the program performs "software filtering" to limit the randomness of some

of the entries, and thereby make the output more pleasing acoustically. You can experiment with additional filtering, bearing in mind that the random number generator may crash if too many values are rejected in

	Control word	PSG Address	PSG Data	Action
1.	11111000 = 248	7	111000 = 58	Enable tones on all PSGs.
2.	11111000 = 248	12	01010000 = 80	Envelope Coarse = 80, about 0.4 Hz.
3.	11111000 = 248	8	10000 = 16	Chan. A volume is envelope-controlled.
4.	10000000 = 128	1	1	C-4, MSB, from Left PSG.
5.	10000000 = 128	0	172 (dec)	C-4, LSB.
6.	10000000 = 128	13	0000	Envelope Shape/Cycle: long decay.
7.	01000000 = 64	1	1	E-4, MSB, from Right PSG.
8.	01000000 = 64	0	83 (dec)	E-4, LSB.
9.	01000000 = 64	13	0000	Trigger the envelope.
10.	00001000 = 8	1	1	G-4, MSB, from Center PSG.
11.	00001000 = 8	0	29 (dec)	G-4, LSB.
12.	00001000 = 8	13	0000	Trigger.
13.	11111000 = 248	13	0000	Retrigger the three notes.

Fig. 9. Sequence of OUT statements needed to play three notes and a C maj chord

FREE...

VERBATIM DATA-LIFE DISKETTES

We'll send you a plastic box of 10 Verbatim Data-Life Diskettes, ABSOLUTELY FREE ... when you purchase any one of the following three items:

APPARATS NEWDOS/80®, 2.0 \$149.95
 HAYES SMARTMODEM 279.00
 ST80 III 149.95

COPY MODEL III SCRIPSIT/VISICALC® \$20.00

Works with all model III Visicalc/scrpsit and allows unlimited backups of master disks. Works even if you're already backed up twice. Simple 17 line program.

TRS 80 AIR NAVIGATIONAL PROGRAM... \$39.95

For FBO'S - Charter - Business - Personal. Plan trips anywhere in the contiguous U.S. Program produces pilot-oriented, flyable, printout of locations in memory, or that you input. Shows trip data leg-by-leg, with mileage between points, MC, Wind correction, MH & GS, fuel per leg, ETE, ETA, Total mileage, time, fuel, average GS, plus fuel management.

Program requires 48K disk and printer

(Specify model I or III). Disk has over 200 locations, expandable to 500. Send \$5.00 for sample printout and instructions.

VERBATIM® DATA-LIFE DISKETTES 5"... \$29.90 box 8"... \$39.90 box

5" Diskettes come in reusable plastic storage box.

LAYMAN'S GUIDE TO NEWDOS/80, 2.0- \$7.50

An easy-to-understand, plain-English guide to the most commonly used features of NEWDOS/80, 2.0.

ST80 III... \$149.95

Smart terminal communications package. Allows file uploading/downloading. Emulates many different terminals. Total oper-

ator control. (Written by Lance Mickus.) - Includes FREE Diskettes. -

HAYES SMARTMODEM®... \$279.00

Talk with other computers over regular Telephone lines. SMARTMODEM can auto dial - auto answer - repeat - allows for audio monitoring - programmable - is FCC approved direct-connect - Full or half duplex capability, 0 - 300 baud - RS-232C interface - seven status LED's. - (Includes FREE Diskettes) -

VISA - Mastercard - Money Orders - COD. Allow 2 weeks for personal checks. Kansas residents add 3.5% sales tax.



256 E. 4th Hutchinson, Kansas 67501
 316/665-3611

"The idea is to scramble the initial seed number."

Program Listing 3 Continued

```

E24A DD2AF6DF 00590 LOOP LD IX,(XLSB) ;ADDRESS OF A(0,0)
E24E DD19 00600 ADD IX,DE ;POINT TO A(N,0)
E250 CD1FE3 00610 CALL RAND ;GET B-255
E253 DD7780 00620 LD (IX),A ;ENTER A(N,0) INTO ARRAY
E256 DD2AF6DF 00630 LD IX,(K2) ;ADDRESS OF A(0,1)
E25A DD19 00640 ADD IX,DE ;POINT TO A(N,1)
E25C CD1FE3 00650 LOOP1 CALL RAND
E25F E60F 00660 AND 15 ;MASK TO GET B-15
E261 FE00 00670 CP 0 ;REJECT IF REG. 0, 2 OR 4
E263 2BF7 00680 JR 2,LOOP1 ; (HANDLED BY 1, 3 AND 5)
E265 FE02 00690 CP 2
E267 2BF3 00700 JR 2,LOOP1
E269 FE04 00710 CP 4
E26B 2BEF 00720 JR 2,LOOP1
E26D FE0E 00730 CP 14 ;REJECT IF REG. 14 OR 15
E26F 2BE8 00740 JR 2,LOOP1 ; (NOT USED)
E271 FE0F 00750 CP 15
E273 2BE7 00760 JR 2,LOOP1
E275 DD7780 00770 LD (IX),A ;ENTER A(N,1) INTO ARRAY
E278 DD2AF6DF 00790 LD IX,(K4) ;ADDRESS OF A(0,2)
E27C DD19 00800 ADD IX,DE ;POINT TO NEXT A(N,2)
E27E FE07 00810 ; FOR PSG REG. 7, MASK OUT TWO (OR THREE) NOISE ENABLES
E280 2802 00820 CP 7
E282 1B11 00830 JR 2,BITS6 ;NEEDS 6-BIT VALUE
E284 CD1FE3 00840 CALL RAND ;BYPASS IF NOT = 7
E287 E63F 00850 AND 3FH ;MASK TO GET B-63
E289 4F 00860 LD C,A ;SAVE IN C
E28A E630 00870 AND 48 ;= 00110000, MASK TO TEST
E28C FE30 00880 CP 48 ; FOR A "1" IN BITS 4 & 5
E290 2802 00890 ; A 56 INSTEAD OF 48 WOULD TURN OFF ALL NOISE CHANNELS
E292 1BF2 00900 JR 2,EQUAL ;MUST EQUAL 11XXXX
E294 79 00910 JR BITS6 ;NOT EQUAL
E296 1B6E 00920 LD A,C ;RESTORE A=0-63
E298 FE06 00930 CP 6 ;PSG REG. 6 NEEDS 5 BITS
E29A 201E 00940 JR 2,BITS5
E29C FE0D 00950 CP 13 ;PSG REG. 13 NEEDS 4 BITS
E29E 2821 00960 JR 2,BITS4
E2A0 FE08 00970 ; FOR PSG REG. 8, 9 OR 10, MASK OUT LOWEST AMPLITUDES
E2A2 202E 00980 CP B ;A CONTAINS PSG REG. NO.
E2A4 FE09 00990 JR 2,AMPL
E2A6 202A 01000 CP 9
E2A8 FE0A 01010 JR 2,AMPL
E2AA 2026 01020 CP 10
E2AC FE0B 01030 JR 2,AMPL
E2AE 2022 01040 CP 10
E2B0 FE0C 01050 JR 2,AMPL
E2B2 2020 01060 ; FOR PSG DOUBLE REG. 1, 3 OR 5, ADD WEIGHTS APPROPRIATELY
E2B4 FE0D 01070 ; AND REJECT HIGHEST NOTES IF MSB = 0
E2B6 202D 01080 CP 1
E2B8 202C 01090 JR 2,DBLE1 ;WILL GET 14-3583
E2BA 202B 01100 CP 3
E2BC 2027 01110 JR 2,DBLE2 ;WILL GET 14-767
E2BE 2025 01120 CP 5
E2C0 2024 01130 JR 2,NOMSB ;WILL GET 14-255
E2C2 2023 01140 JR OUTPUT ;DEFAULT FOR REG. 11 OR 12
E2C4 2022 01150 ;
E2C6 CD1FE3 01160 BITS5 CALL RAND ;FOR PSG REG. 6
E2C8 E61F 01170 AND 1FH ;0-31, 5 BITS
E2CA 2045 01180 JR OUT1
E2CC 2020 01190 ; ELIMINATE SOME CLICKS BY REJECTING SHORT ENVELOPE
E2CE 2020 01200 ; SHAPE/CYCLE CODES: 0000 THROUGH 0111, AND 1111 (BINARY)
E2D0 CD1FE3 01210 BITS4 CALL RAND ;FOR PSG REG. 13
E2D2 E60F 01220 AND 0FH ;0-15, 4 BITS
E2D4 FE08 01230 CP B ;ELIMINATE SOME CLICKS
E2D6 30B2 01240 JR NC,RETEST ;>= 1000 O.K., EXCEPT 1111
E2D8 10F5 01250 JR BITS4 ;GET ANOTHER
E2DA FE0F 01260 RETEST CP 0FH ;= 1111 BINARY?
E2DC 2BF1 01270 JR 2,BITS4 ;REJECT, SHORT CLICKS
E2DE 1B34 01280 JR OUT1
E2E0 CD1FE3 01290 AMPL CALL RAND ;FOR PSG REG. 8, 9 OR 10
E2E2 E61F 01300 AND 1FH ;MASK TO GET 0-31
E2E4 FE03 01310 CP 3 ;REJECT LOW AMPLITUDES,
E2E6 30F7 01320 JR C,AMPL ; < 3
E2E8 1B29 01330 JR OUT1
E2EA CD1FE3 01340 DBLE1 CALL RAND ;PSG REG. 1 IS FULL-RANGE
E2EC B7 01350 OR A ;WITH H=0, TEST FOR MSB=0
E2EE 2B19 01360 JR 2,NOMSB ;IF NO MSB, REJECT HIGHEST NOTES
E2F0 E60F 01370 AND 0FH ;0-15
E2F2 FE0E 01380 CP 0EH ;0-DH FOR MSB
E2F4 3026 01390 JR C,OUT12
E2F6 1BF2 01400 JR DBLE1
E2F8 CD1FE3 01410 DBLE2 CALL RAND ;PSG REG. 3, LIMITED
E2FA B7 01420 OR A ;TEST FOR NO MSB
E2FC 2B0B 01430 JR 2,NOMSB
E2FE E603 01440 AND 3 ;0-3
E300 FE03 01450 CP 3 ;REJECT 3
E302 3018 01460 JR C,OUT12 ;ACCEPT 0-2 FOR MSB
E304 1BF2 01470 JR DBLE2
E306 1480 ;
E308 CD1FE3 01490 NEWL CALL RAND ;GET NEW LSB IF NECESSARY
E30A 7D 01500 NOMSB LD A,L ;WITH H=0, TEST L
E30C FE0E 01510 CP 14 ;REJECT IF < 14
E30E 30F8 01520 JR C,NEWL
E310 1803 01530 JR OUT1 ;BYPASS NEXT

```

Program Listing 3 Continues

a repeating loop. This is due to the fact that computer-generated random numbers are pseudo-random.

The software filtering begins with line 820, which tests whether PSG register 7, enable, was chosen. If so, then two of the three noise channels are shut off. I find it particularly pleasing if all noise channels are turned off, because noise tends to be overly loud compared to tones. After the noise channels are turned off, and a random number of tone channels are on, the resulting PSG data are entered into the array as A%(N,2) by a branch in line 940.

Data for PSG register 6, noise period, are output without filtering. However, data for PSG register 13, identified by line 970, undergo extensive testing to eliminate nine of the 16 available envelope shapes. The eliminated envelope shapes, all sharp attack-decay combinations, produce clicks whenever envelope period is short. You can also force longer envelope periods whenever a sharp attack-decay envelope is selected.

Starting with line 1000, a test is made for amplitude register 8, 9 or 10. Since the PSGs use a logarithmic volume scale, the low volumes are disproportionately quiet. Program line 1320 rejects the lowest three steps of volume control, including 0000, which would turn a channel off.

Multiple levels of software filtering are applied to the tone-generating PSG registers 1, 3 and 5, starting at program line 1080. Since the PSGs can produce frequencies above 110 kHz, I have limited the range to about 8,000 Hz, or B-8, by not permitting codes less than 14 for tone generation. Secondly, the coding of tones, if random, would produce too many low-frequency notes. Therefore, weights are applied to the three tone period channels. Channel 1 is "full range," channel 2 starts at about D-3, and channel 3 covers A-4 to B-8. Random data within these ranges are entered into the array as A%(N,2) for the appropriate MSB tone-generating register. The PLAYBK routine resolves the entry into MSB and LSB and outputs these as a double load.

Subroutine RAND generates the random numbers. The idea is to scramble the initial seed number extensively and to use the freshly-generated number as a seed for a subsequent operation. The interested reader might look up N. Wadsworth's RANNUM subroutine on p. 113 of "Z80 Software Gourmet Guide & Cookbook" (Scelbi, 1979) for an alternative random number generator.

With the software presented, the nine-



AMERICAN

118 SO. MILL ST
PRYOR, OK 74361
(918) 825-4844

SMALL BUSINESS COMPUTERS

ALL PRICES ARE CASH DISCOUNTED 3%. C.O.D. AND CHARGE ORDERS ARE 3% MORE.
RETAIL LOCATION: 447 S. WOOD, PRYOR, OKLAHOMA 74361

DON'T PAY MORE!!

TRS-80 MODEL III

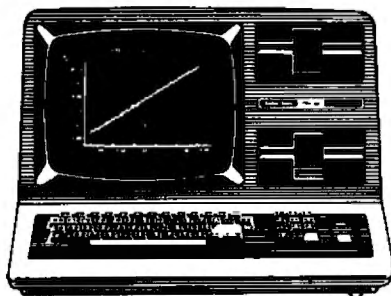

- 16K.....\$825
- 48K.....\$849
- 48K 1 DRIVE.....\$1499
- 48K 2 DRIVE.....\$1749

THERE'S NO SECRET

There's no secret as to why we can sell TRS-80 computer equipment for less. Low overhead — that's the reason — pure, simple and straight! As everyone knows, Radio Shack is a huge corporation...with huge expenses. We are able to buy the bare-bones computers from Radio Shack. To these computers, we add our own memory chips, disk drives, cables, etc. The result is a computer system which is equal to, or in many cases, superior to the one you would get from Radio Shack in both price and performance capabilities. There is one thing that you don't get from Radio Shack — their 90 day warranty. What you get in its place is the exclusive 180 days American Small Business Computer's Warranty. So...if you like the Radio Shack computer, but don't like the price...CHECK US OUT!!!

TRS-80 MODEL II

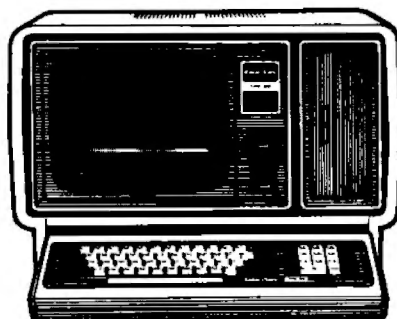

**64K MODEL II
WITH ONE DISK DRIVE**

\$3287⁰⁰

MODEL I, III SOFTWARE

- PROFILE.....\$69.95
- PROFILE III PLUS.....\$175.00
- VISICALE.....\$87.95
- VISICALE III.....\$175.00
- SCRIPSIT.....\$87.95
- SCRIPSIT DICTIONARY.....\$175.00
- SUPER SCRIPSIT.....\$131.00

COLOR COMPUTER

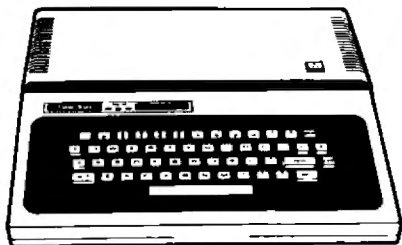

- 4K LEVEL 1.....\$318
- 16K LEVEL I.....\$335
- 16K EXT. BASIC.....\$435
- 32K EXT. BASIC.....\$520
- DRIVE I.....\$499
- DRIVE 2, 3, 4.....\$250

16K RAM NOW ONLY \$16.95

For MOD I, II, III Color Comp.

American Small Business Computers is not an authorized Radio Shack Dealer. We do not offer a Radio Shack 90 Day Warranty on our computers. Instead, we offer the American Small Business Computers **180 Day Warranty**. If you have a problem with your computer, return it to us for about 48 hours. If we can't fix it, we'll replace it!

* TM Tandy Corp.

217

CALL 918-825-4844

“... the nine-voice or 15-voice PSG brand will play a continuously changing repertory of random sounds.”

Program Listing 3 Continued

```

E300 CD1FE3 01540 OUTPUT CALL RAND ;FOR PSG REG. 11 OR 12
E303 DD7700 01550 OUT1 LD (IX),A ;ENTER A(N,2) INTO ARRAY
E306 DD360100 01560 LD (IX+1),0 ; SETING MSB=0
E30A 1806 01570 JR RETURN
E30C DD7500 01580 OUT12 LD (IX),L
E30F DD7701 01590 LD (IX+1),A ;ENTER TWO BYTES INTO ARRAY
E312 13 01600 RETURN INC DE ;ADVANCE ARRAY POINTER
E313 13 01610 INC DE ; BY TWO
E314 2AFEDF 01620 LD HL,(NOTES)
E317 29 01630 ADD HL,HL
E318 AF 01640 XOR A ;CLEAR CARRY
E319 ED52 01650 SBC HL,DE ;END OF ARRAY?
E31B C24AE2 01660 JP NZ,LOOP
E31E C9 01670 RET ;BACK TO BASIC
01680 ;
01690 ; SUBROUTINE TO GENERATE A 16-BIT RANDOM NUMBER
E31F 2A33E3 01700 RAND LD HL,(RSEED) ;GET PREVIOUS RSEED
E322 060F 01710 LD B,15
E324 29 01720 RA ADD HL,HL
E325 7C 01730 LD A,H
E326 17 01740 RLA
E327 AC 01750 XOR H
E328 FA2CE3 01760 JP M,RB
E32B 2C 01770 INC L
E32C 10F6 01780 RB DJNZ RA
E32E 2233E3 01790 LD (RSEED),HL
E331 7C 01800 LD A,H ;FOR CONVENIENCE, PASS
E332 C9 01810 RET ; ALSO IN A
E333 01820 RSEED EQU $ ;SEED FOR RANDOM NUMBERS
00000 01830 END
00000 TOTAL ERRORS

```

voice or 15-voice PSG music board will play a continuously changing repertory of random sounds. You can enter your own array in Data statements to encode a musical score and employ the PLAYBK driver, but this method of entry is laborious. Jerry Yamaguchi has written a machine-language interpreter and a compiler, 2K each, that facilitates score entry. These programs, together with instructions and five demo tunes, can be obtained on disk for a nominal fee by enclosing a SASE and contacting him at 2737 Butler Avenue, Los Angeles, CA 90064. ■

Source code listings 2 and 3 will assemble with two 'Field overflow' errors using Radio Shack's Editor/Assembler. This is due to a design flaw in the Editor/Assembler and not in the source code. The object code, however, will be written correctly.

CONVERT YOUR TRS-80 MODEL-I OR III INTO A DEVELOPMENT SYSTEM



Now you can develop Z-80 based, stand-alone devices such as games, robots, instruments and peripheral controllers, by using your TRS-80 as a development system. The DEVELOPMATE plugs into the expansion connector of your TRS-80 and adds PROM PROGRAMMING and IN-CIRCUIT-EMULATION capabilities to your system (with or without expansion interface).

Complete instructions and sample schematics are included to help you design your own simple stand-alone microcomputer systems. THESE SYSTEMS CAN BE AS SIMPLE AS FOUR ICs: one TTL circuit for clock and reset, a Z-80, an EPROM, and one peripheral interface chip

When the In-Circuit-Emulation cable is plugged into the Z-80 socket of your stand-alone system, the system becomes a part of your TRS-80: You can use the full power of your editor/assembler's debug and trace program to check out both the hardware and the software. Simple test loops can be used to check out the hardware, then the system program can be run to debug the logic of your stand-alone device.

Since the program is kept in TRS-80 RAM, changes can be made quickly and easily. When your stand-alone device works as desired, you use the Developmate's PROM PROGRAMMER to copy the program into a PROM. With this PROM, and a Z-80 in place of the emulation cable, your stand-alone device will work by itself.

The DEVELOPMATE is extremely compact: Both the PROM programmer and the In-Circuit-Emulator are in one small plastic box only 3.2" x 5.4". A line-plug mounted power supply is included. The PROM programmer has a "personality module" which defines the voltages and connections of the PROM so that future devices can be accommodated. However, the system comes with a "universal" personality module which handles 2758, 2508 (8K), 2716, 2516 (16K), 2532 (32K), as well as the new electrically alterable 2816 and 48016 (16K EEPROMs).

The COMPLETE DEVELOPMATE B1, for Model I, with software, power supply, emulation cable, TRS-80 cable, and "universal" personality module \$329
 DEVELOPMATE 83, Model III version, same as above \$329
 PM2 PERSONALITY MODULE for 2732A EPROM \$15
 PM3 PERSONALITY MODULE for 2764 EPROM \$15

ORION
INSTRUMENTS

172 Otis Avenue, Dept. M, Woodside, CA 94062
(415) 851-1172

Master Charge and Visa phone orders accepted
California residents please add 6% sales tax



AMERICAN

118 SO. MILL ST
PRYOR, OK 74361
(918) 825-4844

SMALL BUSINESS COMPUTERS

ALL PRICES ARE CASH DISCOUNTED 3%. C O D. AND CHARGE ORDERS ARE 3% MORE.
RETAIL LOCATION: 447 S. WOOD, PRYOR, OKLAHOMA 74361

EPSON PRINTERS 180 DAY GUARANTEE!!!

We sell the complete EPSON line at the lowest prices!

If you don't believe it, give us a call. But, just as important, we offer an unprecedented **180 Day Warranty!** How do we do it? It's easy. We sell the most reliable printer in the world — EPSON!

✓219

TRS-80* MODEL 1 MINI DISK DRIVES

Our Mini Disk Drives are based on the world famous TEAC Mini Disk Unit. The TEAC Unit features an estimated 8000 power-on-hours mean time between failure (that's 8 hours a day, 5 days a week, for 3.85 years!). Our drives also feature a lead screw head positioner-not a band type positioner. This type of positioner insures accurate head positioning over the read-write media while giving a very quiet, noise-free read-write operation. If you have any doubts about our drives, our **one year warranty** should convince you that we know this unit is the **best** drive at the **best** price on the American market. This is one example where you can pay less and get more!!

\$250

- 40 TRACK SINGLE SIDE.....\$250
- 40 TRACK DOUBLE SIDE.....\$340
- 80 TRACK SINGLE SIDE.....\$340
- 80 TRACK DOUBLE SIDE.....\$475
- VERBATIM DISKETTES.....\$29.95
- 2-DRIVE CABLE.....\$29.95
- 4-DRIVE CABLE.....\$39.95

**COMPLETE DRIVE
WITH POWER SUPPLY**

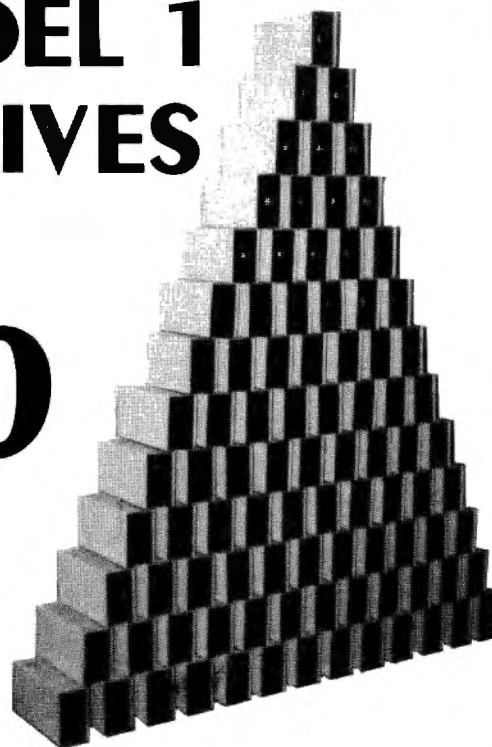

**WE STOCK
DISK DRIVES!**

918-825-4844

✓218



A history of digitally synthesized music.

A Little Byte Music

Steve Levine
P.O. Box 224
Ambler, PA 19002

A great deal of research done has been in the field of digital synthesis and computer music. General purpose digital computers didn't play a significant part until the 1960s. Bell Labs was interested in music synthesis for partly economic and partly academic reasons, and they became the pioneers of this new art form/technology. The Massachusetts Institute of Technology (MIT), Stanford University, Brooklyn College, Columbia/Princeton, Dartmouth and Queens College of CUNY, just to name a few, were also active in research of computer music. Many scientific disciplines found applications for computer music, typical examples being:

- Artificial Intelligence—Automatic scoring of "Masterworks."
- Scientific Analysis—Using the analyzed data of the earth's magnetic field as the basis for a score.
- Digital Signal Processing—Conventional analog signal theory applied to musical sound generations.

Of the memorable systems that were built and programmed in the 60s and 70s the three discussed below were somewhat astounding in their design as well as the sounds they produced.

The Groove System

An acronym for Generating Real-Time Operations on Voltage-controlled equipment, this system was developed in the late 60s at Bell Labs by Dr. Max Matthews and F. R. Moore. It consisted of a vast array of laboratory-quality sound generators and mod-

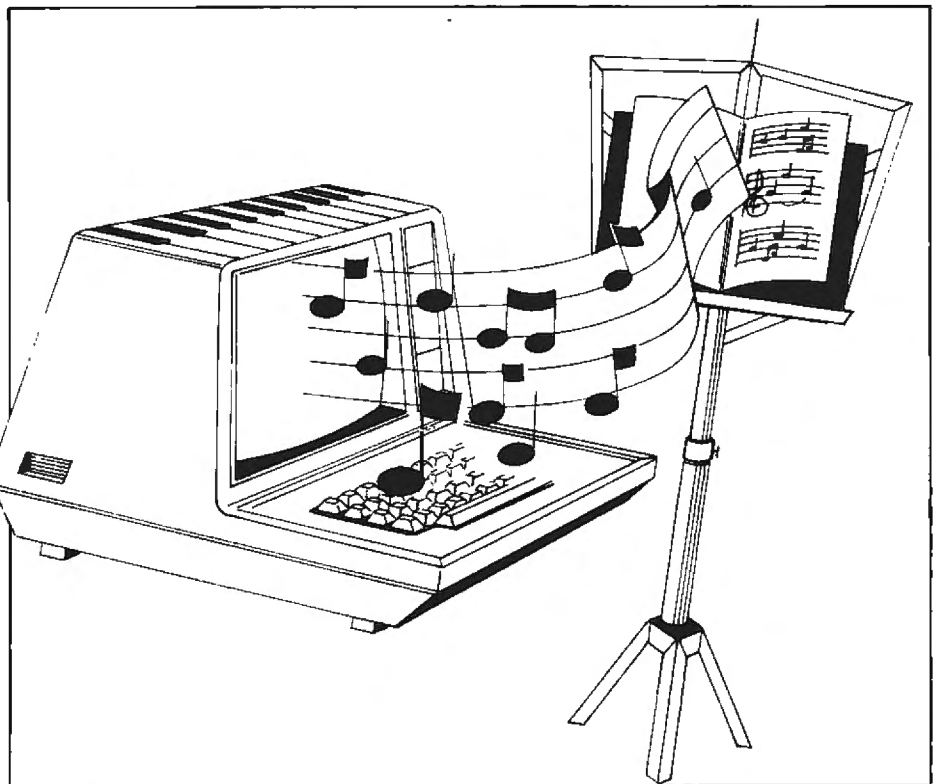

fiers, which were electrically coupled to input control devices such as joysticks, pots, switches, music keyboards and a drawing tablet. The computer was involved in the processing of events in time. A composer could write a Fortran program that would process input and treat temporal events in any way you could program it. The result was algorithmic control over the synthesis process.

The Hal Alles Digital Synthesizer

In the 70s Dr. Harold Alles of Bell Labs designed a fully digital synthesizer based on microprogrammed architecture doing sine-wave additive synthesis. It incorporated an LSI-11 minicomputer and scores of analog input devices, which were processed by the LSI-11.

The device was a self-contained perform-

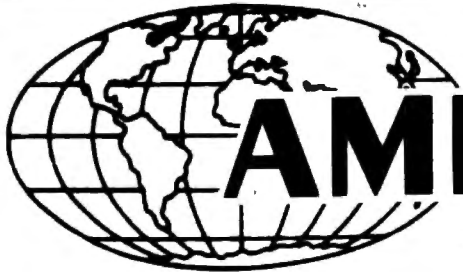

AMERICAN

SMALL BUSINESS COMPUTERS

118 SO. MILL ST
PRYOR, OK 74361
(918) 825-4844

ALL PRICES ARE CASH DISCOUNTED 3%. C.O.D. AND CHARGE ORDERS ARE 3% MORE
RETAIL LOCATION: 447 S. WOOD, PRYOR, OKLAHOMA 74361

32K EXPANSION INTERFACES

These Expansion Interfaces are Brand New, with original documentation and in perfect working condition.

Notice: These prices are good only through June 1, 1982. After June 1, 1982, the price will be \$399.00

\$329⁹⁵

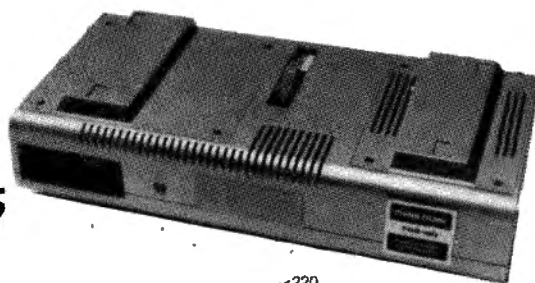

✓220

CAMEO HARD DISK DRIVES FOR TRS-80 MODEL II

The Cameo Hard Disk offers TRS-80 Model II users 10 million bytes of on-line disk storage. Five million bytes are stored on a standard non-removable disk platter. The second five million bytes are stored on a removable "disk pack". This configuration allows, for example, the accounts receivable to be stored on one disk pack, accounts payable on still another disk pack, mailing list on another, etc., etc.

The Cameo also allows up to four computers to share the same disk drive. This means one person working at one computer can be updating accounts payable, while another person working at another computer can be retrieving records from a data base. So...when your business needs soar beyond a floppy disk limitations, call AMERICAN SMALL BUSINESS COMPUTERS and ask for THE CAMEO CONNECTION.

CALL FOR PRICING INFORMATION

★ Dealers needed for all Cameo Hard Disk Products ★



✓221

TRS-80™ Daisy Wheel Printer II

By Radio Shack

Yes, this is the same Daisy Wheel sold by Radio Shack for a couple of hundred bucks more. This is just one more reason why it really pays to shop American Small Business Computers.

\$1649⁹⁵

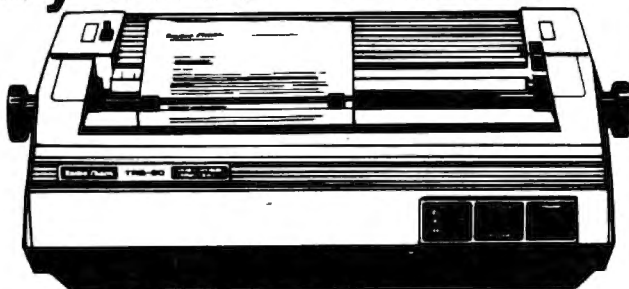

918-825-4844

TRS-80 PRINTERS

- Line Printer V.....\$1635
- Line Printer VI.....\$1020
- Line Printer VII.....\$325
- Line Printer VIII.....\$619

✓222

“The latest comer to the computer music world, and probably the first practical digital synthesizer.”

ance system with two rank digitally scanned music keyboards, a CRT display, alpha-numeric keyboard, 72 studio quality slide pots, several joysticks, and two eight-inch floppy disks. The synthesizer section contained 32 F.M. sine-wave oscillators with .002 Hz. resolution, 32 F.M. oscillators capable of generating harmonics up to the 127th partial, 32 second-order (two-pole) digital filters, 32 four quadrant multipliers (digital), two seconds of digital reverb, four channels of 16-bit D/A converter output, two 14-bit A/D inputs, and 255 timers with 16 of their own fifos for holding and shuffling timing events.

The sample rate of the system is 30 kHz. The system creates music by specifying various aspects of the piece from input controller data as well as from files of algorithmically generated music. The device is capable of real-time performance, but with a slight degradation in throughput, as opposed to preparing performance control information in advance, which resulted in a substantial savings in throughput power.

The Fairlight CMI

The latest comer to the computer music world, and probably the first practical digital synthesizer, the CMI took a totally new approach for control than had any other machine before it. Designed and built by a couple of Australians named Peter Vogel and Kim Ryrey and costing a mere \$35,000, this musical instrument won the favor of many rock stars. I had the great fortune of harboring one for about 18 months or so in exchange for some technical support and paper presentations at various conferences.

The Fairlight produced sounds in two distinct ways; reverse FFT, and the sampling of real sounds for playback and manipulation.

There were also many ways in which to input control information into the instrument including: a light pen for drawing arbitrary waves or splicing/editing waveforms, pots or footpedals, music keyboards (up to eight in all), and an ASCII keyboard for algorithmic control from a composition language.

The most characteristic sound possible and which eventually became the trademark was the sampled sound called “LO-STRING.” This was taken from a tape recording of the London Philharmonic Orchestra string section all playing the same note simultaneously! The effect was astounding. By playing one note on the keyboard you could sound like the entire or-

chestra string section all by yourself. (This presented some interesting legal questions.)

As far as additive synthesis is concerned, one could create individual harmonic envelopes for each of 32 harmonics out of a pallet of 128, with scaling and temporal adjustment. The effect was usually unpredictable since there was not enough fine control to recreate all the spontaneous harmonic envelopes involved in the very important attack portion of the wave. Also it is quite difficult to specify this information from just a list of line segment or Fourier spectrum analysis datum. Nevertheless, I enjoyed the CMI and learned a great deal from it. It had two eight-inch floppy disks and was a general purpose multi-tasking computer as well.

The sequencer and composer language together provided a very flexible environment to create musical scores and just plain jam. I could write For...Next loops, play the notes into the composer and the program would score it on the screen as I played. The composer did not retain the timing information, but that could be hand typed on the ASCII keyboard later on. By playing in the general pitch and then making loops and dynamic constructs, one could create almost impossible sequences that would play tirelessly and perform nested permutations while you just sat back and listened in awe!

One more thing about the composer and sequencer: You could convert composer files into sequencer files so they could be used as bass lines or drum kits or repeating chorus backgrounds for live, fully expressed and recorded sequences. The backgrounds could be overdubbed or merged with the new tracks as in a multi-track tape recorder.

Another neat feature is the ability to draw arbitrary waveforms into a graphic “page” using the light-pen for different manipulations. You can merge, mix, rotate and redraw waveforms and display them in two-dimensional or pseudo-three-dimensional form on the CRT. We also merged human voice samples with real musical instruments forming totally new synthetic sounds.

The Fairlight CMI made use of very good ergonomics (human engineering) to interface the user with this vastly complex device. It has inspired many new instruments.

Fundamentals of Digital Synthesis

All digital synthesis involves sampling.

If sound is to be output from a computer, it must first be converted from numbers to analog voltages. An analog waveform may be broken up into many discrete levels and then stored as a long string of numbers. The waveform may be created entirely from a mathematical function or be digitized from a real sound in the outside world. However it is created, it must eventually be converted by a digital to analog converter. In most cases, a D/A converter is essentially a resistor ladder fed by a current source with each leg of the ladder having one of the “N” bits tied to its input. When a number is fed to the inputs of the resistor network, the current is summed according to the binary weighting of the individual resistors, usually the reciprocal of powers of two. D/A converters are very important in digital synthesis and are always a prime consideration in determining the quality of a digital synthesizer.

Look for the following qualities in D/A converters: the number of bits (determines the dynamic range = $n \text{ bits} \times 6 \text{ dB}$), speed or settling time (governs the highest frequency that can be sampled), and linearity (contributes to the accuracy of the reproduced waveform).

Synthesis is accomplished when waveform samples are output to the D/A converter at twice the highest synthesis frequency. The sample rate must be at least two times the highest frequency in order to avoid alias or foldover frequencies. This foldover is called the Nyquist frequency.

Examples of the Nyquist theorem can be found in western movies. When a western wagon rolls across the screen, the wheels seem to be revolving backward. This is due to the rotation frequency of the wheels being faster than the frequency of the camera shutter sample rate. The movie film (sample converter) is not receiving enough samples per second to accurately reproduce the rapidly moving (repeating wave) wheel. The result is an image whose camera frequency is a sub-multiple of the original wagon wheel. The formula for predicting foldover is:

$$Af = Sr - F \quad \begin{array}{l} Af = \text{alias frequency} \\ Sr = \text{sample rate} \\ F = \text{frequency to sample} \end{array}$$

Generally, sound is synthesized by computing waveform tables with several different waveforms in their own memory areas. The main program starts outputting samples to the D/A converter at a rate conforming to the above rules. In most cases, however, the converter is limited by the cycle-



AMERICAN

SMALL BUSINESS COMPUTERS

118 SO. MILL ST
PRYOR, OK 74361
(918) 825-4844

ALL PRICES ARE CASH DISCOUNTED 3%. C.O.D. AND CHARGE ORDERS ARE 3% MORE.
RETAIL LOCATION: 447 S. WOOD, PRYOR, OKLAHOMA 74361

DISCOUNT SOFTWARE FOR THE TRS-80

FARM & RANCH MANAGEMENT PROGRAMS

BEEF PROJECTION—This program simulates feeding situations for beef cattle. \$20.00
BEEF RATION—This program evaluates energy, protein, calcium, and phosphorus content of ration specified by the user. \$15.00
DAIRY COW—This ration evaluator computes the daily requirements for specified cow weight, milk production, and butterfat content. \$15.00
FEED LOG—This pen record tracks each pen of cattle on costs accumulated. It prints a status report on any pen, and a close-out when all costs and income have been entered. \$35.00 (Models I and II), \$100.00 (Model III)
FARM RECORD—This program is a general farm bookkeeping program. It is capable of 52 income and 47 expense categories with inventories, net worth, 9 employee payrolls, 9 external accounts payable/receivable, 5 bank accounts, and 5 enterprises. \$38.00
GOVERNMENT PROGRAM—This program compares participation with non-participation in wheat-feed grain-cotton programs under various assumptions about yields, production costs, and market prices. \$15.00
GRAIN STORAGE—This program computes the cost per bushel for on-farm storage, interest, shrink and miscellaneous costs for on-farm or commercial storage for 6 time periods. \$15.00
LOAN—This program computes either interest rate, payment amount, amount of loan or years of loan when the other three variables and number of payments per year are entered. \$15.00
MACHINE COST—This program calculates the average annual depreciation, interest, repairs, fuel and labor costs per hour and per acre, for machines or vehicles, for each year of ownership. \$20.00
RECORD MANAGEMENT—This is a general purpose program for entering, correcting, sorting, or searching data files such as cow records, field records for crops, machinery parts lists, mailing lists etc. \$15.00
ESTATE TAX—This program prints anticipated Oklahoma and Federal taxes for specified estates of individuals/spouses. It allows for the testing of various distribution strategies. \$25.00
FEED FORMULATOR—The Feed Formulator calculates the least-cost ration for up to 20 nutritional constraints and up to 30 ingredients. \$35.00
PASTURE PROJECTION—This program projects gains and income expense from pasture for beef cattle. \$20.00

HARDWARE REQUIREMENTS FOR THE ABOVE PROGRAMS: (MINIMUM) TRS-80 Model I or III with 48K and one disk drive. For Model II Versions of the above programs, please add \$5.00 per program (Feed Log Program Add \$80). Buy all the above programs and save even more! Model I and III Versions only \$250.00 (Save \$30). Model II Versions Only \$350.00 (Save \$55).

**NEW DOS/80 2.0
OR
DOS PLUS 3.4
YOUR CHOICE, ONLY
\$139**

BIG FIVE

- Supernova
- Attack Force
- Cosmic Fighter
- Meteor Mission
- Defense Command

\$18.95 — Disk

\$12.95 — Cassette

RADIO SHACK SOFTWARE MOD I, III

PROFILE.....\$69.95
PROFILE III PLUS.....\$175.00
VISICALE.....\$87.95
VISICALE III.....\$175.00
SCRIPSIT.....\$87.95
SUPER SCRIPSIT.....\$175.00
SCRIPSIT DICTIONARY.....\$131.00

MICROSOFT

ADVENTURE.....\$23.00
OLYMPIC DECATHALON....\$24.95

DOS PLUS 3.4 and NEWDOS/80 2.0 are two of the most advanced operating systems ever available for the TRS-80. After spending thousands of dollars on your computer, why limit yourself by using an inferior operating system? Order Today!!

CALL

918-825-4844

DEALER INQUIRIES INVITED

223

★ ATTENTION SOFTWARE AUTHORS ★

American Small Business Computers is one of the nation's largest suppliers and distributors of TRS-80 related software. If you have a program which you would like to market, please contact Ms. Jeanie Phillips at American Small Business Computers. She will test and evaluate each program received. If the program meets our high standards, an offer of acceptance, along with our terms, will be returned with the software. All types of games, business and scientific programs will be considered. Highest royalties are now being paid for Color Computer programs.

"To make real music, form a 'playlist' (a la computer graphics 'displaylist'). . .

time of the microprocessor software. The resulting output is deglitched by a sample and hold circuit and then low-pass filtered to prevent some of the higher alias frequencies from being heard.

If you want to change voices or possibly mix a few on their way out, simply pick samples from the different wavetables and 'accumulate' or sum them up just before they are output to the D/A converter. This is limited by the sample-rate as usual. The number of simultaneous voices possible is usually proportional to the sample rate.

To make real music, form a 'playlist' (a la computer graphics 'displaylist') consisting of pitch and duration specifications for the various voices. Frequency is changed by taking the pitch or note number and using it as an increment into the continuous waveform table. The table, which is thought of as being circular, causes it to produce a lesser or greater cycle time.

A more scientific way to visualize this process is plotting the entire waveform on graph paper. Using one square as the unit of one half the sampling rate, you can hop through the table picking out every sample ending with the lowest frequency of that waveform on our new plot. If you take every other sample (two squares at a time) and replot them on a different sheet, you will see a waveform twice the frequency of the first, and so on. The larger the increment, the higher the frequency. In essence, you are going from one end of the table to the other in fewer samples, resulting in a waveform whose phase crosses zero more frequently (assuming that the sample rate is fixed). Try it on paper, or on your computer screen.

Waveforms have to come from somewhere. In the above example they usually come from a method known as Fourier Analysis. Named after the French mathematician, this technique is widely used in

analysis of periodic phenomena of all types — from visual spectral, to vibration, to chromatography, to audio analysis. The latter is responsible for much of the work done in digital synthesis.

Simply, the FFT (Fast Fourier Transform), breaks a complex wave consisting of many harmonics or partials into its component parts. This process is accomplished by higher mathematics and the analog to digital conversion of the source signal in question. The computer uses an analog to digital converter to fill up a table in memory consisting of the sound waveform, say a clarinet for instance (*Computer Music Journal* Vol. 1, #1, James A. Moorer). A certain number of samples are taken as some multiple of the sample rate divided by the amount and bit size of the memory buffer available. The algorithm extracts periodic wave patterns representing the individual harmonics and builds a table of harmonic strengths for as many harmonics as the algorithm is designed for. This resulting information, sometimes called "Power Spectrum," is used to reconstruct the original source waveform, usually with less harmonic content than is found in the original waveform. This time-consuming process is not done in real time.

The results of the FFT are valuable in providing compressed forms of real waveforms and also resynthesizing or creating new instruments using the process in reverse. Harmonics can be resummed and the complex wave may be resynthesized by specifying the harmonic number and its power (usually some kind of amplitude envelope for the harmonic).

A great deal of data is required for synthesis. To derive the important and useful coefficients to drive a Fourier synthesizer to create a horn-type sound, a data base must be built describing the horn within the limitations of the synthesis hardware and performance control. If you attempt to manipulate the dynamics of the synthesis process, you must create waveforms which sound sensible when manipulated.

Analog Synthesis Under Computer Control

The concept of controlling an analog synthesizer originated at Bell Labs in the 1960s. Dr. Max Matthews was responsible for developing some of the early software and hardware.

In principle, a voltage-controlled device such as an oscillator or filter would have one or more of its parameters swept by a varying voltage, whose function would be

ESTATE PLANNING MODEL SAVE TIME AND MONEY

by using your TRS-80* Model II, 64 K computer
for professional estate analysis.

- ☆ **Marital Deduction Formula Analysis Reports** analyze six formula bequests for both husband and wife for both orders of death.
- ☆ **Estate Tax Return Report** computerizes estate tax planning for decedents' estates.
- ☆ **Client-Ready Reports** printed.
- ☆ **State (Ohio) and Federal Taxes** computed.
- ☆ **Free Updates** to reflect legislative changes for one year.
- ☆ **Sold and maintained by author:** an attorney and estate planning professional.
- ☆ **ALREADY REVISED** to comply with 1981 TAX REDUCTION ACT.

YES, please send me more information on the
Estate Planning Model.

Name _____

Name of Firm _____

Street _____

City _____ State _____ Zip _____

Mail to: Beard Software Development Co.
59 Skyline Avenue
Canfield, Ohio 44406

*TRS-80 is a trademark of Tandy Radio Shack

134



AMERICAN

118 SO. MILL ST
PRYOR, OK 74361
(918) 825-4844

SMALL BUSINESS COMPUTERS

ALL PRICES ARE CASH DISCOUNTED 3%. C.O.D. AND CHARGE ORDERS ARE 3% MORE.
RETAIL LOCATION: 447 S. WOOD, PRYOR, OKLAHOMA 74361

DISCOUNT PRINTERS

EPSON—CALL FOR PRICES

OKIDATA

MICROLINE 80.....\$350
MICROLINE 82A.....\$469
MICROLINE 83A.....\$719
MICROLINE 84.....\$1015

C. ITOH

PROWRITER.....\$499
F10-40.....\$1450
F10-55.....\$1750

Paper, Ribbons and Other Accessories are also available

✓ 224



TRS-80[®]



DISCOUNT COMPUTERS

It is the stated goal of CLEVELAND ELECTRONICS to sell TRS-80 computers and peripherals at the lowest prices in the WORLD. We ask that you call other dealers, check your local Radio Shack store and mail order houses and then call us LAST (Toll Free, of course). We think that you will be pleasantly surprised.

So... give us a call TODAY!

WE NOW SELL - EPSON

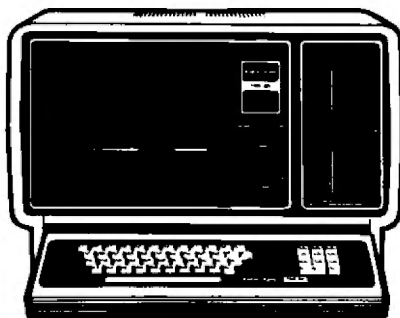

FOR TOLL FREE ORDERING
AND PRICE QUOTES, CALL:
1-800-331-3896

CLEVELAND ELECTRONICS

121 BROADWAY ✓ 225
CLEVELAND, OK. 74020
1-800-331-3896

TRS-80 MODEL III
IN STOCK

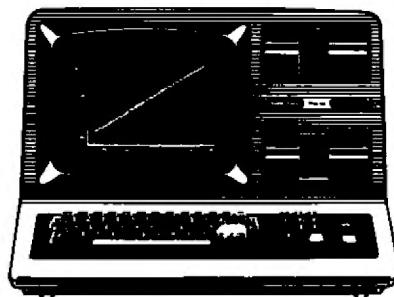

THE ULTIMATE IN COLOR COMPUTING

WORD PROCESSING

THE SUPER "COLOR" WRITER II

The Word Processor that re-wrote the book on Word Processing

The Super "Color" Writer is a FAST, machine code, full featured, character (screen) oriented word processing system for the TRS-80(TM) Color Computer and ANY printer. The video display is styled after a professional phosphor (green characters on black background) display for hours of use without eye fatigue (optional orange on black). The unique print WINDOW frees you from 32, 51 or 64 character lines FOREVER! This window can be moved anywhere in the text file, up, down, left or right to display the text as it will be printed without wasting paper. You can create or edit Super "Color" Terminal files, ASCII files, BASIC programs or Editor/Assembler source listings. It's simple enough for beginners with 4K and...for the professional writer with a 32K disk system and a lot to say, there's plenty of room to say it!

COMPARISON CHART	SUPER COLOR WRITER			THE COMPETITION		
	4K	16K	32K	4K	16K	32K
System Size						
TAPE: Text space	N/A	8K	24K	N/A	2K	18K
ROMPAK: Text space	2.5K	15K	31K	N/A	N/A	N/A
DISK: Text space	N/A	6.5K	22.5K	N/A	0.5K	16.5K
Right Justify		YES			NO	
Video Window		YES			NO	
Edit any ASCII File		YES			NO	

The figures speak for themselves and with professional features like PROGRAMMABLE function string commands to perform up to 28 commands automatically, PROGRAMMABLE text file chaining, PROGRAMMABLE column insert & delete, and right hand JUSTIFICATION with punctuation precedence, the choice is clear but there's still more!

The Super "Color" Writer takes full advantage of the new breed of "smart printers" with Control codes 1-31, 20 Programmable control codes 0-255 for special needs and built in Epson MX-80, Centronics 737, 739 and R.S. Line Printer IV, VII, VIII drivers.

CHECK THESE FEATURES!!

HIGH SPEED & normal operations • 32K Compatible • Window • Key beep • HELP table • 128 character ASCII & graphics • Memory left • Lower case • Full cursor control • Quick paging • Scrolling • Word wrap around • Tabs • Repeat all functions • Repeat last command • Insert character & line • Delete character, delete to end of line, line to cursor, line & block • Block move, copy & delete • Global Search, Exchange & Delete • Merge or Append files • Imbed Control Codes in text • Underline • Superscripts • Subscripts • Headers, Footers & 2 Auxiliary footnotes on odd, even or all pages definable position • Flush right • Non-breakable space • 4 centering modes: 5, 8.3, 10 & 16.7 (CPI) • Full page & print formatting in text • Single sheet pause • Set Page length • Line length, Line spacing, Margins, page numbers • Title pages • Printer baud: 110, 300, 600, 1200, 2400 • Linefeeds after CR • Soft & hard formfeed • Works with 8 bit printer fix • and more!

SUPER "COLOR" WRITER DISK

The Disk version of the Super "Color" Writer works with the TRS-80C Disk System and has all the features listed above plus many more! Use with up to four Disk Drives. Includes an extended HELP table you can access at any time. Call a directory, print FREE space, Kill disk files and SAVE and LOAD text files you've created all from the Super "Color" Writer. Print, merge or append any Super "Color" Terminal file, ASCII file, BASIC program or Editor/Assembler source listing stored on the Disk of tape. The Super "Color" Writer Disk version has additional formatting and print features for more control over your printer and PROGRAMMABLE chaining of disk files for "hands off" operation. Print an entire BOOK without ever touching a thing!

Includes comprehensive operators manual.

TAPE \$49.95 ROM PAK \$74.95 DISK \$99.95

Manual only, \$7.00 Refundable with purchase.

Allow 2 extra weeks for personal checks. C.O.D. orders add \$2.00. When ordering specify computer type and add \$2.00 for S/H. Minn. residents add 5% sales tax. VISA/Master Chg.

DEALER INQUIRES ARE INVITED.

TRS-80 is a registered trademark of the Tandy Corp.

COMMUNICATIONS

THE SUPER "COLOR" TERMINAL

Time Share, Smart Terminal, High-speed Data X'fer & Videotex

The Super "Color" Terminal turns the Color Computer into a Super-smart terminal with all the features of VIDEOTEX(TM) plus much more. COMMUNICATE with Dow Jones & Compuserve and with computers like the TRS-80(TM) MODEL I, II, III, APPLE etc., via modem or RS-232 direct! Save the data to tape or print it! Reduces ON-LINE cost to a minimum!

FEATURES

10 buffer size settings from 2-30K • Buffer full indicator • Lprints buffer contents • Full 128 ASCII keyboard • Compatible with Super "Color" Writer files • UPLOAD & DOWNLOAD ASCII files, Machine Language & Basic programs • Set RS-232 parameters • Duplex: Half/Full • Baud Rate: 110, 300, 600, 1200, 2400, 4800 • Word Lengths: 5, 6, 7 or 8 • Parity: Odd, Even or None • Stop Bits: 1-9 • Local linefeeds to screen • Tape save & load for ASCII files, Machine code & Basic programs • Unique clone feature for copying any tape.

Super "Color" Terminal Disk

The Disk version offers all the features listed above plus Host ability in full duplex • Lower case masking • 10 Keystroke Multiplier (MACRO) buffers on disk to perform repetitive log-on tasks and send short messages (up to 255 bytes) • Programmable prompts for send next line • Selectable character trapping • Set printer line length • Pagination • Linefeed with CR option • Printer Baud: 110, 300, 600, 1200 & 2400 • Documentation.

TAPE \$39.95 ROM PAK \$49.95 DISK \$69.95

Documentation only, \$4.00 Refundable with purchase.

16K RAM KIT \$15.99

PREMIUM 16K 200 Ns Ram for TRS-80 Color Computer. Includes ram test instructions and a ONE YEAR GUARANTEE. 32K upgrade instructions FREE! (32K requires soldering)

ROMPAK KITS

Put your programs in a ROMPAK or execute tape based programs in a RAMPAK at \$COOO. Kit includes 1 socketed P.C. board that holds up to 4, 2716 EPROMs or 4, 2K Static Ram Chips for a total of 8K and a plastic housing to fit the rom port. \$24.95

2716 2K 5v EPROM \$5.95 ea.

2K Static RAM \$19.95 ea.

COLOR GAMES!!

FEATURING GREAT GRAPHICS & SOUND!

ADVENTURE 3-PAK Requires 16K Extended Basic. **TAPE \$24.95**

This TRILOGY OF 3-D FANTASY GAMES takes you to the WORLD UNDER THE CIMEEON MOON. Engage in ritual combat with Tooamoath Narthokc Monsters and skilled warriors. Advance in rank with play experience. Then adventure through DAZMAR'S UNDERWORLD OF DOOM to the forbidden ruins of Castle Argaan. Search for the Eye of Dazmar while avoiding the sorcerer's intricate traps. Survivors must then negotiate the perilous peaks of the Ugrek Mountains to the FORSAKEN GULTCH where the wicked idol awaits restoration.

VEGAS 5-PAK Requires 16K Extended Basic **TAPE \$19.95**

The THRILLS OF A VEGAS CASINO at home. Five action packed Vegas games for up to four players: CASINO CRAPS • 21 • ONE ARMED BANDIT • UP & DOWN THE RIVER • KENO. Bank tracks players' winnings from game to game • realistic cards • regulation tables • boards • authentic sounds • lively graphics • official rules in each game.

COMBAT 3-PAK Requires 16K Extended Basic **TAPE \$24.95**

Three action packed two player games featuring lifelike graphics and sound of LASER FIRE, CANNONS and PHOTON TORPEDOES.

2-1-0 TANK COMBAT five terrains • the experienced arcade player can design combat scenario. **STELLAR BATTLE** pilot a Flex-Wing Fighter at incredible speeds in enemy space taking out Dorian Tye Fighters defending the Imperial Star Fortress. **GALACTIC BLOCKADE** maneuver your craft in a course that boxes your opponent but avoid cosmic debris and hostile space probes!



**NELSON
SOFTWARE
SYSTEMS**



✓ 128

P.O. Box 19096 Minneapolis, MN 55419 612/827-4703

“With significant advances in hardware for digital synthesis abounding, we are left the job of creating software.”

controlled by the computer (usually through the use of a D/A converter). By connecting conventional control devices, (keyboards, pots, joysticks and so on) and using an A/D converter to sample the input devices, a real-time performance can be achieved.

Today most of the circuitry for implementing these voltage-controlled modules can be found on monolithic integrated circuits for a fraction of their original module cost. A few manufacturers make microcomputer-oriented subsystems using this technique. One makes a complete system with one generation, filtering and performance system.

Some of the possibilities with analog control are:

- Algorithmic generation of musical scores
- Computed timbre control
- Complex sequence generation and storage
- Algorithmic processing of human control input

This is all possible due to the fact that analog sound generation does not require processor time to create the basic sound. A short Basic or assembler program may be executed within the time that a Vco D/A must be updated. The necessary D/A converter is usually not of the high-speed type but should be at least 12 bits wide to allow small increments in frequency. The Vco usually has a very wide range of voltage to frequency control. The same is true of VCFs and VCAs as well.

Sound Generators

Although sound generators are listed in the resource table, they are not considered seriously for music synthesis purposes. They range from such things as the General Instruments AY3-8910 to Texas Instruments hybrid chips.

The basic principle of the 8910 is the use of frequency and amplitude control registers which are written into and whose values are continually used to produce sound without further processor intervention. The amplitude values are used as crude scaling (15 different levels) for square waves which are not musically precise throughout their entire range (Uneven Temperament). There is also a set of noise generators on chip. The chip is fun, but it usually finds its way into pinball machines and arcade video games.

The hybrid type T1-76477 and family contains voltage-controlled oscillators on chip with limited wave-shape output. There are a

few bits of digital input control, but only for selected different modes and patches. For example, you can route the oscillator to a VCA, mix noise with oscillators, and so on — not very flexible for creating music, just noise or sound effects for games.

With significant advances in hardware for digital synthesis abounding, we are left with the job of creating software. This can free our personal computer to monitor slow processes such as performance input (algorithmic controlled) and sequencing as well as creation and analysis of musical data.

Many of the products available for small computers today allow the user to write his or her own routines or interface home-brew hardware with the system. Some of the products are not oriented toward the experimenter, but are more performance oriented. They simply play music like a player piano (once they have been loaded or composed onto). These systems range from being a

novelty to an effective musical experimentation and training aid.

Since the techniques above require a lot of time to execute as well as a lot of memory and good converters, we haven't yet seen practical instruments based on these methods. Some of the products available, however, come pretty close for the money. I am surprised at the level of software sophistication that is reached by the personal computer music industry. I am also impressed by the untapped capabilities of these systems.

One should not judge small-computer music systems by their stand-alone merit as a performing do-everything musical instrument. There should definitely be more accent on the experimenter system and the small researcher (this could be you or me) in his or her attic or basement. We are the ones that work out most of the problems and do most of the experimentation. We will

NEW CLASSICS SOFTWARE

239 FOX HILL ROAD · DENVERVILLE NEW JERSEY 07834 · TELEPHONE 201-625-8838

PASCAL 80 by Phelps Gates

“If anyone could devise a good PASCAL system for the TRS-80® it was Phelps Gates. I am happy to report he has done just that.”

BYTE, Dec. 1981, pg. 304

“After trying out...(the competition) I found myself using PASCAL 80 exclusively.” Creative Computing, Nov. 1981, pg. 96

PASCAL 80 is the friendliest PASCAL available anywhere! Monitor, editor, and compiler are in memory at the same time, avoiding time consuming and annoying disk access and disk switching. Yet, it uses standard PASCAL syntax and leaves 23K of work space in 48K (32K at run time).



PASCAL 80 has 14 digit accuracy and requires a 48K TRS-80® with one disk drive. It comes in a binder with easy and complete user instructions for \$99. Add \$2 shipping and handling per order and specify Model I or Model III.



Credit card orders: (201) 625-8838

NEW CLASSICS SOFTWARE
239 Fox Hill Road
Denville, NJ 07834

(PASCAL 80 does not implement variant records, pointer and window variables, or functions and procedures used as parameters.)

✓ 255

“There is great amount of research being funded by the Department of Defense, . . . a heavy user of powerful signal-processing integrated circuits.”

be the ones to write about it, or feed it back to the manufacturers.

Computers in the Arts

There are presently two festivals that I know of to date that deal directly with computer music and related technology. The Symposium on Small Computers in the Arts (Box 1954, Philadelphia, PA 19105) is sponsored by the Philadelphia Area Computer Society and the Philadelphia Chapter of the IEEE Computer Society. This festival combines computer graphics and computer music tutorials as well as demonstrations of equipment, sale of books, periodicals and hardware for both areas.

The International Computer Music Conference is held at a different world-wide site each year. This is the academic community's gathering of minds. The conference has a patron publication, the *Computer Music Journal* (28 Carlton St., Cambridge, MA

02142), which is highly esteemed in the field and published by the MIT press. In addition there are always the personal computer fairs such as the Trenton Computer Festival and the West Coast Computer Fair.

The Future of Computer Music

The computer music industry can only grow as fast as the demand for these virtually limitless instruments. There is a great amount of research being funded by the Department of Defense, a heavy user of powerful signal-processing integrated circuits. The U.S. Navy has been funding research to IBM and others for the development of VHSIC (very high-speed integrated circuits). There is a good chance that a general purpose Fourier transformer capable of audio bandwidth generation of dozens of simultaneous complex waveforms on a single VLSI (very large-scale integration) Cmos chip will be available in the next five years. It will be

only a small example of the types of pioneer technology that will find its way into alternative uses.

As for the near future, there is still software to be written for the devices currently available. The possibilities are becoming more and more interesting. ■

For a list of currently available micro and minicomputer music products compiled by Steve Levine, send an SASE to Janet Flerio, 80 Microcomputing, 73 Pine St., Peterborough NH 03458.

Steve Levine is a computer systems engineer whose experience ranges from micro and minicomputer design and programming to digital synthesis research and development. Steve has also been co-chairman of the IEEE Symposium on small computers in the arts for the past four years (formerly the Personal Computer Arts Festival).

ARCADE FAVORITES

- ALL GAMES WRITTEN IN M/C CODE FOR FAST REAL TIME GRAPHICS WITH SOUND.
- SUIT TRS-80 MODEL I & III OR PMC-80.
- ALL GAMES 2 PLAYERS WITH TOP 10 SCORES.
- ALL GAMES LOCATED 5200H OR HIGHER WITH NO LOADER TO FACILITATE EASY PLACEMENT ON DISK.

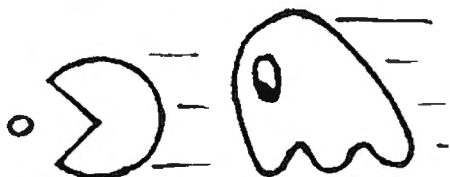

GHOST HUNTER.

Gobble up the dots before a ghost gobbles you. Eat a power pill and it is your turn to chase the ghosts.

INSECT FRENZY.

Fight off an attack from the savage centipede but keep an eye out for the giant spider, it can appear anytime.



HOPPY.

Get your frog across the busy highway without being flattened. Then cross the river by means of jumping on logs and diving turtles.



ALL GAMES \$16.95 each.

MAKE ALL CHECKS AND MONEY ORDERS PAYABLE TO: DUBOIS AND McNAMARA.

DEALER ENQUIRIES WELCOME (415) 441-3080

POST TO: 495 ELLIS, SUITE 356

SAN FRANCISCO, CA 94102-1996

Now my accounting systems run on CP/M as well as TRSDOS.

So they'll work with your micro, no matter which it uses.

I'm Irwin Taranto, and I originally designed my Model II systems to work with TRSDOS, the operating software Radio Shack supplies with the TRS-80.

I designed them extremely carefully, with features other microcomputer accounting systems don't have. Mine all integrate with the general ledger, and, where it helps, they integrate with each other.

My general ledger system gives year-to-year comparisons, in dollars and percentages. It figures budgets and it even has a report generator.

My accounts receivable systems can do sales analysis by product code and figure in salesmen's commissions. They generate mailing lists by customer code or zip code for up to 2000 customers. You can choose either an open item system or a balance forward system which works on a cash or an accrual basis.

My payroll system can handle up to 600 employees in multiple departments, with any state tax routine (we provide them all). It can make any miscellaneous deductions you ask it to — it even does tips and meals.



TRSDOS and TRS-80 are trademarks of the Tandy Corporation.
CP/M is a trademark of Digital Research Corporation.

My inventory control system stores up to 5000 items. It can report by vendor, tell you when you're out of stock or when you need to reorder. It can update price or cost automatically, and integrates fully with my invoicing system.

There's a lot more, too. Over the years, I've had thousands of phone conversations with my customers, working out the bugs and kinks and adding desirable features. Everybody talks about "user-oriented" systems, but because of all these phone calls, it really means something when I say it. These may well be the most thoroughly researched small business accounting programs in the world.

They're also the best supported, at least as far as microcomputer systems go. If you have a problem, just call. If your problem is tough enough, I'll get on the phone myself. There's no charge for phone assistance, ever.

All these calls keep me upgrading my systems constantly. If you own one, you're eligible for a standing offer I've made all along: send me your diskette, and I'll send you the latest upgrade for only \$25.

Now I've taken another step. More and more owners are switching over to CP/M software these days. It seems to be where the whole microcomputer industry is heading.

That's fine with me, because I've just converted all these accounting systems, and can sell them for the prices I've listed:

General Ledger/Cash Journal	\$ 299
Accounts Payable/Purchase Order	349
Open Items Accounts Receivable/Invoicing	349
Balance Forward Accounts Receivable	399
Payroll	299
with Job Costing Option	399
Inventory Control	399

For mail-order programs, these prices may seem high. But for serious accounting programs, nothing can touch them.

Michael Tannenbaum, the "80 Accountant" in *80 Microcomputing*, just called them "a very impressive product at a very reasonable price."

Our TRS-80 Model I and Model III systems aren't quite as sophisticated. But they're tremendous buys at \$99 each (\$149 for general ledger).

So call me and take your choice — CP/M or TRSDOS. Same price, same support. My systems are ready and waiting.

Taranto
& ASSOCIATES, INC.

✓ 70

121 Paul Drive, San Rafael CA 94903
Outside California, toll free (800) 227-2868. In California, (415) 472-2670.

Birth of a legend.



Epson.

A whole new generation of Epson MX printers has just arrived. And while they share the family traits that made Epson famous — like unequalled reliability and ultra-fine printing — they've got a lot more of what it takes to be a legend.

For instance, they've got a few extra type styles. Sixty-six, to be exact, including italics, a handy subscript and superscript for scientific notation, and enough international symbols to print most Western languages.

What's more, on the new-generation MX-80, MX-80 F/T and MX-100, you get GRAFTRAX-Plus dot addressable graphics. Standard. So now you can have precision to rival plotters in a reliable Epson printer. Not to mention true backspace, software printer reset, and programmable form length, horizontal tab and right margin.

All in all, they've got the features that make them destined for stardom. But the best part is that beneath this software bonanza beats the

Uh...three legends.

heart of an Epson. So you still get a bidirectional, logical seeking, disposable print head, crisp, clean, correspondence quality printing, and the kind of reliability that has made Epson the best-selling printers in the world.

All of which should come as no surprise, especially when you look at the family tree. After all, Epson *invented* digital printers almost seventeen years ago for the 1964 Tokyo Olympics. We were

the first to make printers as reliable as the family stereo. And we introduced the computer world to correspondence quality printing and disposable print heads. And now we've given birth to the finest printers for small computers on the market.

What's next? Wait and see. We're already expecting.

EPSON
EPSON AMERICA, INC.

3415 Kashiwa Street • Torrance, CA 90505 • (213) 539-9140

FEATURE	ORIGINAL MX-80	GRAFTRAX-80*	ORIGINAL MX-100	MX-80 with GRAFTRAX-Plus	MX-80 F/T	MX-100
Bidirectional printing	X	X	X	X	X	X
Logical seeking function	X	X	X	X	X	X
Disposable print head	X	X	X	X	X	X
Speed: 80 CPS	X	X	X	X	X	X
Matrix: 9 x 9	X	X	X	X	X	X
Selectable paper feed			X		X	X
PAPER HANDLING FUNCTIONS						
Line spacing to n/216		X		X	X	X
Programmable form length	X	X	X	X	X	X
Programmable horizontal tabs	X	X	X	X	X	X
Skip over perforation			X	X	X	X
PRINT MODES AND CHARACTER FONTS						
96 ASCII characters	X	X	X	X	X	X
Italics character font		X		X	X	X
Special international symbols				X	X	X
Normal, Emphasized, Double-Strike and Double/Emphasized print modes	X	X	X	X	X	X
Subscript/Superscript print mode				X	X	X
Underline mode				X	X	X
10 CPI	X	X	X	X	X	X
5 CPI	X	X	X	X	X	X
17.16 CPI	X	X	X	X	X	X
8.58 CPI	X	X	X	X	X	X
DOT GRAPHICS MODE						
Line drawing graphics				X	X	X
Bit image 60 D.P.I.		X	X	X	X	X
Bit image 120 D.P.I.		X	X	X	X	X
CONTROL FUNCTIONS						
Software printer reset		X		X	X	X
Adjustable right margin			X	X	X	X
True back space		X		X	X	X
INTERFACES						
Standard — Centronics-style 8-bit parallel	X	X	X	X	X	X
Optional — RS-232C current loop w/2K buffer	X	X	X	X	X	X
RS-232C x-on/x-off w/2K buffer	X	X	X	X	X	X
IEEE-488	X	X	X	X	X	X

*Tandy TRS-80 block graphics only available with GRAFTRAX 80.

ABCDEFGHIJKLMNOP abcdefghijklmn ABCDEFGHIJKLMNOP abcdefghijklmn 01234
 ABCDEFGHIJKLMNOP abcdefghijklmn ABCDEFGHIJKLMNOP abcdefghijklmn 01234
 ABCDEFGHIJKLMNOP abcdefghijklmn ABCDEFGHIJKLMNOP abcdefghijklmn 01234
 ABCDEF abcdef ABCDEF abcdef 0123456
 ABCDEFGHIJKLMNOPQRSTUVWXYZ abcdefghijklmnopqrstuvwxyz ABCDEFGHIJKLMNOPQRSTUVWXYZ abcdefghijklmnopqrstuvwxyz 01234567
ABCDEF abcdef ABCDEF abcdef 0123456
 ABCDEFGHIJKLMNOP abcdefghijklmn ABCDEFGHIJKLMNOP abcdefghijklmn 01234
 ABCDEFGHIJKLMNOPQRSTUVWXYZ abcdefghijklmnopqrstuvwxyz ABCDEFGHIJKLMNOPQRSTUVWXYZ abcdefghijklmnopqrstuvwxyz 01234567

Small Computers in the Arts symposium a disappointment.

The Philly Phiasco

by David Gunn
106 Midway
Riverton, NJ

This review is a composer's comments on the state of the art in computer synthesized music and graphics as presented at the Philadelphia Computer in the Arts Symposium held in November. David Gunn is an accomplished musician and writer

whose compositions have been performed across the country.

The IEEE's Symposium of Small Computers in the Arts in Philadelphia, left me with a feeling of discombobulation.

You see, the goal of the Institute of Electrical and Electronics Engineers (IEEE) was "to increase the participant's awareness of the uses of small computers in the arts and to provide a forum for information ex-

change." The key word here is "arts." Apparently, no one connected with the Symposium had a very clear idea of what the word meant in this day and age, so they did what any logical non-artist would do—they checked the dictionary . . . and found "Art: a shortened form of Arthur."

But their reasoning persisted. Arthur Who? There are several choices:

- Arthur, some legendary British king who yanked a sword out of a rock. (But you don't need a computer for this kind of work; you need a pair of vise grips!)

- Arthur Murray, a famous dancing fellow. (While this might not seem significant at first, consider: renowned Bell Computer Labs is located in Murray Hill, New Jersey. Coincidence? You be the judge.)

- Chester Arthur, last of the 'so what?' U.S. presidents. (Alas, no computer connection here, either.)

This lack of information on the arts must have left them feeling a bit ill at ease . . . but hope springs eternal from the human who's at home in the computer world. So, on with the show.

First, there was the little matter of my getting in without springing for the \$75 entrance fee. With a little creative effort, I had an official-looking press pass.

Inside, things were in a minor state of disarray as last minute logistical considerations switched around available space. Chris Morgan (Editor in Chief of *Byte*) officially opened the festivities with a keynote address, the theme of which was "never trust a computer you cannot lift."

The seminars were equally divided between musical applications and graphic applications—or, stuff to hear and stuff to watch. The best of the watching stuff was high-tech computer art from big machines



What is "Art"?

“...after I had savored 90 minutes of predictable software transcriptions of Bach, Bacharach and the Beatles, the rest of the symposium began to take on a definite charm.”

under the auspices of culturally astute institutions like NASA and Bell Labs. Nice imagery...but created on equipment that takes more than pin money to run. So the next time you lose a quarter in a pay phone, just consider you are in some way helping to fund Industry's equivalent of Bugs Bunny.

The computer music applications, however, intrigued me. I wondered what advances had been made since I had dabbled in it during my college days. Was the electronic synthesizer finally to be embraced by audiences as well as composers due to its increased accessibility? Were strange and exciting new sounds now capable of being generated by the mere flick of a switch, the tap of a button?

Sadly, these questions remained unanswered. Example after example of computer-music spewed forth from shiny synthos, but nothing new, nothing remotely innovative was produced—just the same old beeps and boops you have heard before. Three days worth of this electronic show and tell spawned only tedium and unimaginative noises. How is this possible?

At first, I attributed it all to Murphy's Law: When three and four seminars are running simultaneously and only one could be attended, the others would be necessarily more interesting. So when, for example, I had to decide between "Advanced Software Music Synthesis: Delayed Playback," "Uses of Small Computers in Music," and "Graphics on the Apple II and Atari Computers," I assumed I had just chosen wrongly, again.

But gradually the thought occurred to me that perhaps these guys were simply in some sort of cultural vacuum, and really endorsed Chris Morgan's remark that "composers should send an audience out whistling—or trying to whistle—the tune." In other words, stay with the status quo.

Four of the tutorials were conducted by Hal Chamberlin. They consisted largely of paraphrasing parts of his book, *Musical Applications of Microprocessors*, which sold for \$24.95 at the nearby computer arts store, in case you wanted to follow along. The culmination of his presentations was his software rendition of J.S. Bach's *Tocata and Fugue in D Minor*. . . nothing new here—he programmed it in 1977.

But wait—he did have a *new* piece he was working on; it consisted of six notes. Well, no one ever said that composition was easy.

Hold on, you say. You have no right to

pick on these people so much!

Perhaps you're right. After all, they did seem to be quite serious about their Art. (They must mean the Murray fellow.)

On second thought—if I don't, who will?

There were other demonstrations, to be sure. One of the designers of the Synergy digital synthesizer had to keep whacking his prototype against a table to get it to function properly. Another person, diddling with a Datamax computer, demonstrated a graphics language which allows non-programmers to make a bunch of squiggles, calling it "advanced animation." Still another was content to discuss his micro-processorized pipe organ, surely a revolutionary step forward in the annals of computer music.

But the best was still to come, i.e., the Fourth Annual Philadelphia Computer Music Concert. To put this in perspective, after I had savored 90 minutes of predictable software transcriptions of Bach, Bacharach and the Beatles, the rest of the Symposium began to take on a definite charm.

How can you go through ten entire tunes without changing timbre parameters? Or the volume—couldn't the volume have been varied once in a while?

Apparently not.

And that was the good part.

The bad part was labeled an "improv session" (that's when you have not practiced together long enough to get it down right) with three musicians (their word): a keyboardist playing an alphaSyntauri synthesizer, a drummer, and a female vocalist. After the vocalist recited a T.S. Eliot poem with her back to the audience, after the keyboardist banged out the sort of "blues" one hears mostly over supermarket sound systems, and after the drummer watched for ten minutes for a good spot to hit his cymbal, I started to get this uneasy feeling—musical indigestion.

It was all dentist's office music—inoffensive melodic pablum.

No, not quite. I was offended. Minor league rock 'n' roll has no business on a program allegedly reflecting the forefront of computer music. In fact, *none* of the stuff belonged on the program. It was as exciting as hearing "Bolero" being played on the piano.

At any rate, the final day was set aside for last minute spiels by synthesizer representatives gamely trying to hawk their machines, and a closing plenary session. During the latter, it was announced that the

Symposium had made a profit (a financial one, that is, as opposed to an intellectual one). Also mentioned were two frequently overlooked artistic applications of computers which might find their way onto next year's program: designing athletic footwear and building model ships.

That is when I finally threw in the towel and left.

Some weeks later, I had a chance to talk with the folks at New England Digital (designers of the Synclavier II) and asked them why they had not attended the Symposium. They admitted they had been to one a couple of years ago, and found it lacking in direction and substance, and decided it wouldn't be particularly worthwhile attending another one.

If you're interested in the cutting edge of computer application in the arts, I agree. But hey, if shoes and boats are your bag, then next year's show is for you! ■

NEW PROGRAMS FOR THE TRS-80

INCOPROP

Income Property Analysis for the TRS-80



INCOPROP: Based upon standardized methods of property analysis used throughout the real estate industry. Generates a 3 page report containing an annual property operating statement and a comprehensive 10 year cash flow analysis. Contains I.R.S. tax table to project after-tax income stream and investor's I.R.R.

- Handles 5 different methods of tax depreciation
 - Handles up to 3 loans & 3 different type loans
 - Highly interactive format permits "Sensitivity Analysis"
 - Disk files created for permanent storage of data
- Minimum system requirements: 32K RAM, 1 drive and printer. Sold with informative 78 page user's manual covering basic aspects of income property investment & 50 data worksheets.

Model I & III only. Available for easy transfer to disk. \$129.00
 Model II only. \$89.00. Includes software. \$129.00
 Model II only. Version 1.0 available on MS-DOS. \$129.00

MAINDEX: An easy to use program to aid you in the indexing of your files on disk. Can't find that program you wrote last month? Put your computer to work! Find any program or data file in your system in seconds.

- A Main Index of all your other disk's directories
 - Alphabetizes list of files and gives you names, dates used, dates written, tracks and file descriptions
 - Sorts Files by name, disk and categories
 - File descriptions can be searched for key words
 - Prints disk labels with disk name and file names
 - Uses all the advanced and extremely fast file manipulation capabilities of Apparat, Inc.'s NEWDOS-80.
- Requires Level II 66K, 1 disk drive and NEWDOS-80. \$29.95 (available for easy transfer to disk)

VISA  177  MasterCard



DEPT EM, PO BOX 591, NOVATO, CA 94947



And other factors relating to music generation.

Programming Pitch

Merton L. Davis
3A Palmetto Arms
Camden, SC 29020

Have you ever wished you could hear how a piece of sheet music sounds but lacked skill on a musical instrument? Or even possessing such a skill, have you wished to practice a duet with an exacting partner at the tempo of your choice? With these three requirements: a Model I, Level II 16K computer; a stereo with an auxiliary input; and the ability to read music and type, you can now do so.

This Basic program allows the user to play the entire range of 88 keys on the piano at a chosen tempo. Data statements in Program Listing 1, lines 1-107, load the machine language generator that must accompany the Basic driver. The music generator accepts a note read by the Basic driver; interprets it in terms of a vibration period and sends a vibration at that frequency to your stereo speaker.

Basic Program Description

The Basic program reads each note (or rest) and the value of the note (from 1/64th to whole) and the tempo you wish to play it. The data is supplied to the machine language program for tone generation and returned to Basic for the next note. Since a working knowledge of the Basic program is essential, flowcharts are provided in Figs. 2a, 2b, and 2c.

Lines 5-107 contain the data to POKE the machine language into memory. Line 110 saves the memory and does the POKEing. If the checksum is correct in line 115, the program goes to line 340 where you are assured that the machine language is properly entered. Lines 1-15 are then deleted, and the ready signal is given.

Lines 120 and 340 constitute the general Basic driver. All lines beyond line 340 are special for the piece of music you wish to play. I like to save the program through line 340 on tape and then merge from my musical data file the music of my choice.

Line 130 zeroes two flags, G and H, and asks for a tempo AP at which you wish to play the number. The G flag allows reading either the note paired with its value in line 140 or the single note alone. The H flag allows one repeat to the beginning of the piece. When H equals one the program knows it is in a repeat cycle.

The tempo AP is set to a single precision number AT at 1/5th the value of AP. The range of AP values of 1-20 from fastest to slowest is suggested. Any decimal value up to 20 is permissible, subject only to the confines of the value of a 2-byte integer as explained below.

Line 140 reads the music data starting at line 1000. Depending on G, it reads either the note string NT\$ paired with B (the note value) or NT\$ alone. G is set in the program for passages in which the note value (or B-value) is unchanging. A table of B-values

is in Fig. 3. NT\$ is a three-character string that identifies one of 88 notes on the piano keyboard. The first character (A-G) defines the note; the second (N, S, or F) indicates a natural, sharp or flat; the third (from zero to seven) tells the octave. The program plays all notes from AN0 to CN7.

Line 150 sets RK, an integer product of B and AT. RK is used only to compute the duration of the rests. This computation is detailed when we come to lines 220-240.

Line 155 prevents a string equal to two or greater than three from reaching the machine language program. Line 155 is one of three lines that should be deleted after your music data is debugged. Deleting this line results in a good legato effect and the best note versus rest timing relationship. Lines 185 and 235, the other two lines to delete, protect against entering a note in the upper register for too long a duration and against excessively long rest durations.

Line 160 directs the program to line 210 where all cases of NT\$ not being a note but an integer from zero to nine are treated. Line 170 finds C, the VARPTR location of NT\$, and passes it to the USR location for determining P. P is the vibration period for the particular note.

Line 180 calculates a single precision A that defines the playing duration of the note. A is directly proportional to B and AT and indirectly to the period P. The proportionality constant 1950 assures that even at the lowest period on the keyboard, the first term in the expression to evaluate A will be one. 1.1 is added to assure an A-value of no lower than two. If you ask for a long duration note in the high upper register of the piano keyboard, the A could become greater than 65535 and line 185 stops the program.

Line 190 determines the D-value, the integer passed on to the machine language

Line Numbers	Function
1-115	Saves memory and loads machine language program. Lines are automatically deleted after first RUN entry.
120-130	Sets parameters for playing notes.
140-160	Reads music data and directs to effects other than notes.
170-200	Sets period P and duration D to play the note.
210	Determines L-value that directs to non note-playing features and to special effects.
220-240	Sets rest parameters.
250-300	Directs program to special effects or to end music.
310-320	Plays the note or rest.
350-480	Special effects for "Carmen March". This part is changed for each particular piece.
1000-1220	The music data. Change for each piece.

Fig. 1 Basic Program Summary

The Key Box
Basic Level II
Model I
16K RAM

TUNE-UP YOUR TRS-80®

TRS-80 INFORMATION SERIES - VOLUME III

Dennis Bathory Kitz:
**THE CUSTOM TRS-80.
& OTHER MYSTERIES**

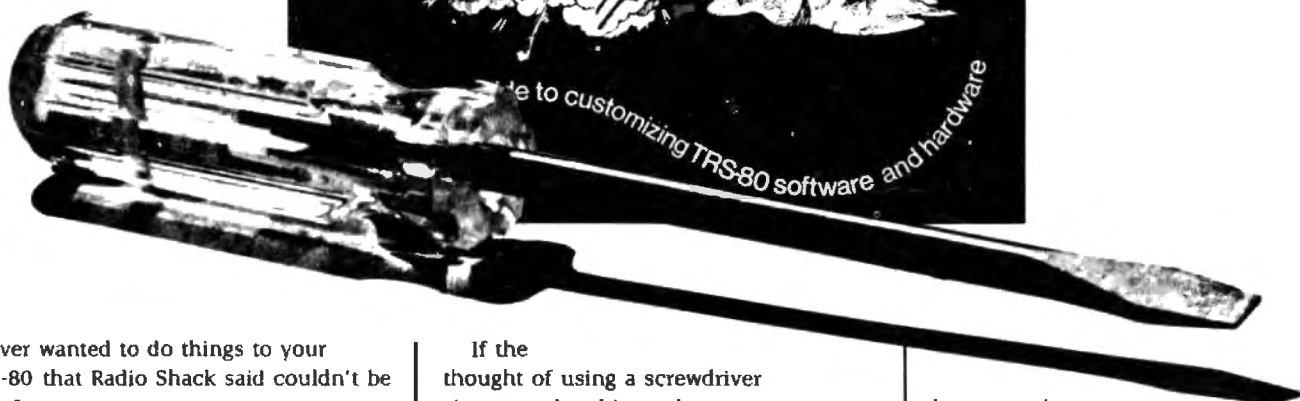

Ever wanted to do things to your TRS-80 that Radio Shack said couldn't be done?

How about upper/lower case, reverse video, high-resolution graphics, a high-speed clock, audible keystrokes, an extra keyboard, and a real-time clock?

Still not enough?

How about using an 8-track as a mass storage device, making music, controlling a synthesiser, monitoring your data bus, and individual reverse characters? All these hardware modifications, plus lots more, are in *The Custom TRS-80 and Other Mysteries* by Dennis Bathory Kitz - the latest book from IJG Computer Services.

If the thought of using a screwdriver gives you the shivers then you can turn to the software section. In this you learn



1260 West
Foothill Bl.
Upland, CA
91786 (714)
946-5805

ON SALE NOW!

how to make BASIC programs auto-execute, reset the memory size, patch into the interpreter, test memory with machine-language, pack program lines with machine code, and generate sound effects.

The Custom TRS-80 and Other Mysteries is more than 300 pages of practical information, and tested software, for \$29.95. Order your copy now, and start turning your TRS-80 into a five-hundred-dollar supercomputer! Pick one up at your local IJG dealer and B. Dalton bookstores.

TRS-80 is a Trade Mark of the Tandy Corporation

"It may be deleted but the timing constants suggested in this program may no longer apply."

program telling it the duration of the note. The program then goes to line 310 where the second USR entry is set and the note is played (line 320) with the period P passed to the machine language.

Line 200 prints out the note and the note value on the video monitor just before it is played. This is especially useful during debugging. It may be deleted but the timing

constants suggested in this program may no longer apply. Unlike lines 155, 185, and 235, the rest timing constants were computed with line 200 present.

Line 210 directs the program to line 250 if the value of the one-character note string is other than zero. If it is zero, then a rest is recognized and treated in lines 220-240.

Line 220 sets D equals one which the

machine language program recognizes as a rest. Three constants (CK, DK, and EK) are then set for the quadratic equation that computes AD, the rest duration in line 230. It was found that a B-value expressing the duration of a quarter note (for example) is not precise in time for a quarter rest unless AD is determined as a power function of RK (the product of B and AT). Furthermore, be-

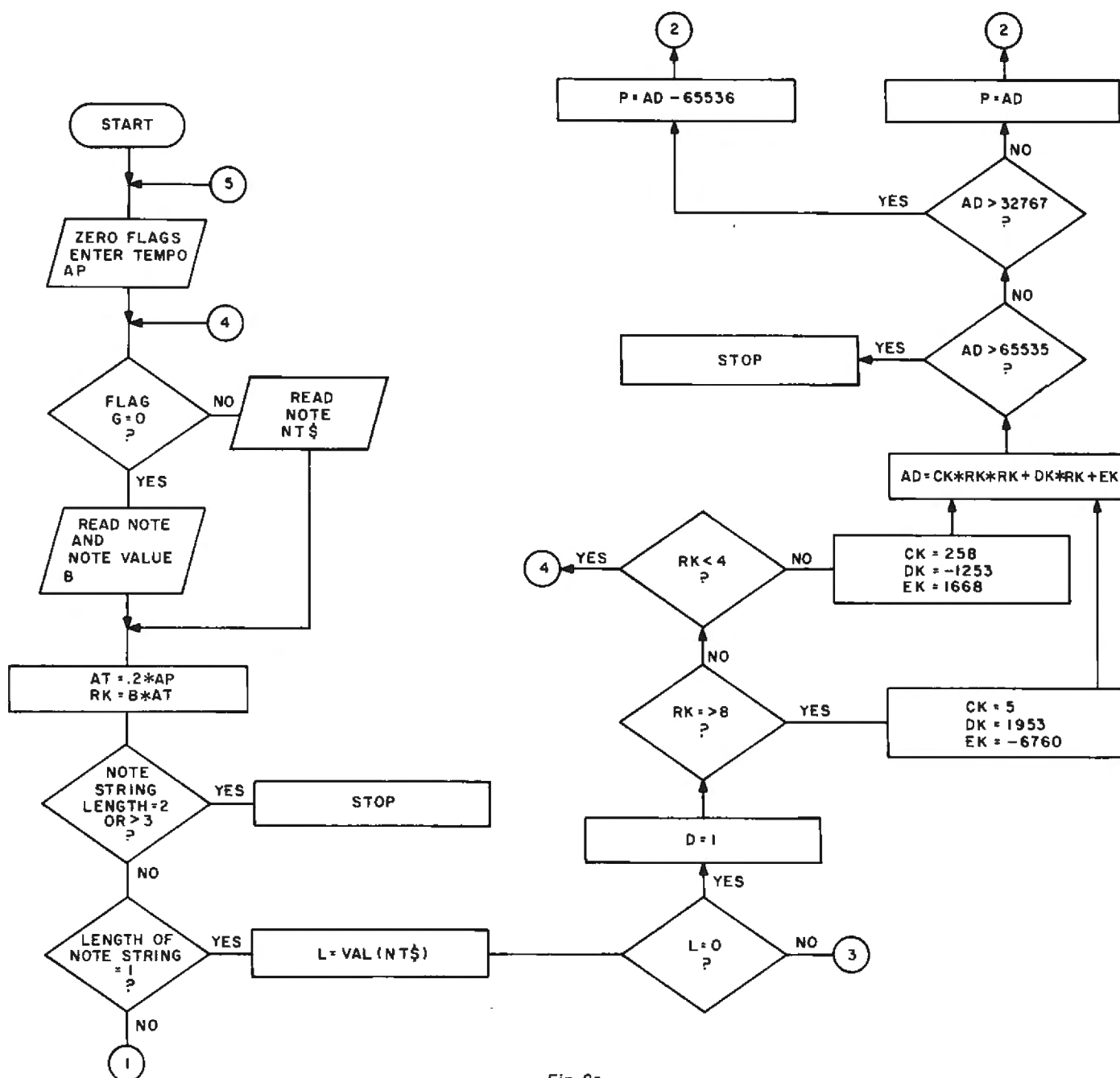

Fig. 2a

TELEWRITER

the Color Computer Word Processor

the only one with all these features for your TRS-80 Color:

51 column x 24 line screen display ■ Sophisticated full-screen editor

Real lower case characters ■ Powerful text formatter

Works with any printer ■ Special MX-80 driver

Runs in 16K or 32K ■ Disk & cassette I/O

requires absolutely no hardware modifications

TELEWRITER

Telewriter is the powerful word processor designed specifically for the Color Computer. It can handle almost any serious writing job and it is extremely easy to use. It has all the advanced features you need to create, edit, store, format and print any kind of text. With Telewriter you can quickly produce perfect, finished copy for letters, reports, term papers, articles, technical documentation, stories, novels, screenplays, newsletters. It is also a flexible and efficient way to take notes or organize ideas and plans.

51 x 24 DISPLAY

The Color Computer is an incredibly powerful and versatile computer, but for text editing it has some major drawbacks. The small 32 character by 16 line screen format shows you too little of the text and, combined with its lack of lower case letters, bears little resemblance to the way text really looks on the page. Reverse video in place of lower case just adds confusion.

Telewriter eliminates these shortcomings with **no hardware modifications required**. By using software alone, Telewriter creates a new character set that has **real lower case letters**, and puts 24 lines of 51 characters on the screen. That's more on-screen characters than Apple II, Atari or TRS-80 Model III. That's more than double the Color Computer's standard display.

FULL SCREEN EDITOR

The Telewriter editor is designed for maximum ease of use. The commands are single key (or single key plus control key), fast, and easy to remember. There is no need to switch between insert modes and delete modes and cursor movement modes. You simply type. What you type is inserted into the text at the cursor, on the screen. What you see on the screen is always the current state of your text. You

can move quickly through the text with one key cursor movement in all 4 directions, or press the shift key simultaneously for fast, auto-repeat. You can jump to the top or bottom of the text, the beginning or end of a line, move forward or backward a page at a time, or scroll quickly up or down. When you type past the end of the line, the wordwrap feature moves you cleanly to the next

... one of the best programs for the Color Computer I have seen . . .

— Color Computer News, Jan. 1982

You can copy, move or delete any size block of text, search repeatedly for any pattern of characters, then instantly delete it or replace it with another. Telewriter gives you a tab key, tells you how much space you have left in memory, and warns you when the buffer is full.

FORMAT FEATURES

When it comes time to print out the finished manuscript, Telewriter lets you specify: left, right, top, and bottom margins; line spacing and lines per page. These parameters can be set before printing or they can be dynamically modified during printing with simple format codes in the text.

... truly a state of the art word processor . . . outstanding in every respect.

— The RAINBOW, Jan. 1982

Telewriter will automatically number pages (if you want) and automatically center lines. It can chain print any number of text files from cassette or disk without user intervention. You can tell it to start a new page anywhere in the text, pause at the bottom of the page, and set the Baud rate to any value (so you can run your printer at top speed).

You can print all or any part of the text buffer, abort the printing at any point, and there is a "Typewriter" feature which allows you to type straight to your printer. Because Telewriter lets you output numeric control codes directly (either from the menu or during printing), it works with **any printer**. There's even a special driver for the Epson MX-80 that lets you simply select any of its 12 fonts and do underlining with a single underline character.

CASSETTE AND DISK I/O

Because Telewriter makes using cassette almost painless, you can still have a powerful word processor without the major additional cost of a disk. The advanced cassette handler will search in the forward direction till it finds the first valid file, so there's no need to keep retyping a load command when you are lost in your tape. The Verify command checks your cassette saves to make sure they're good. You can save all or any part of the text buffer to disk or cassette and you can append pre-existing files from either medium to what you have in the buffer already.

AVAILABLE NOW

Telewriter turns your Color Computer into the lowest cost hi-power word processor in the world today. It runs in 16K or 32K (32K recommended) and is so simple you can be writing with it almost immediately. It comes with 63 pages of documentation and is fully supported by Cognitec. Telewriter costs \$49.95 including shipping (California residents add 6% tax). To order, specify disk or cassette and send check or money order to:

Cognitec
704 Nob Ave.
Del Mar, Ca. 92014

Or call (714) 755-1258 weekdays 7 AM-4PM PST. We will gladly answer your questions.

Apple II is a trademark of Apple Computer, Inc.; Atari is a trademark of Atari, Inc.; TRS-80 is a trademark of Tandy Corp.; MX-80 is a trademark of Epson America, Inc.

➤ 121

MICROSETTE

DISKETTES CASSETTES

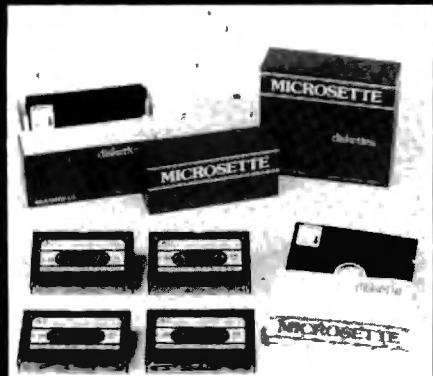

Microsette's reputation for quality and credibility has made us the leading supplier of low cost, short length cassettes. Now, we also offer 5 1/4-inch single sided, soft sector diskettes in single or double density. We give the same attention to quality and reliability for our disks as we do for our cassettes.

LOOK AT OUR PRICES
includes boxes and shipping

CASSETTES Boxes included

Item	10 Pack	50 Pack
C-10	\$ 7.50	\$ 32.50
C-20	9.00	39.00
C-60	11.00	50.00
C-90	15.00	70.00

DISKETTES 5 1/4-inch

MD-5	\$25.00	\$110.00
------	---------	----------

UPS shipment in Cont. USA incl.
We can not ship to P.O. Boxes

Length	Qty.	Price	Total
SUBTOTAL			
Calif. Cust. add Sales Tax			
TOTAL			

Shipping address enclosed
 Check or money order enclosed
 Charge to: Visa MasterCard
 Account No. _____
 Expiration Date _____

SIGNATURE _____

312

MICROSETTE CO.

475 Ellis St., Mt. View,
CA 94043 (415) 968-1604

"... it was found best to bypass the overhead and return directly to line 140 for the next note."

cause of the sheer overhead of treating rests in the program, two sets of constants had to be determined—one for the cases where RK is greater than or equal to eight (where the overhead is small relative to the AD value) and the second case where the overhead is more (the region of RK values between 4 and 8). When RK values are less than four (a sixteenth rest played at an AP tempo of five) it was found best to bypass the overhead and return directly to line 140 for the next note.

The two sets of constants in line 220 were determined experimentally by taping notes having RK values varying from 2-64. By

playing back through one side of the stereo and simultaneously playing a note half-value (1-32) plus a rest half value, an AD value could be determined for each RK. The constants of line 220 were then calculated by linear regression. If you wish to make significant changes in the portion of the program that treats rests, or that which treats notes, you may have to redetermine the CK, DK, and EK constants.

Line 230 determines the AD value. Integer arithmetic is used to conserve time as much as possible. The AD value could exceed the value of a 2-byte integer in which case the program is stopped in line 235. If this hap-

Program Listing 1

```

1 'MUSIC--A PROGRAM FOR A 16K MODEL I LEVEL II TRS-80
2 'BY M. L. DAVIS
3 ' 3A PALMETTO ARMS
4 ' CAMDEN, S. C. 29020
5 DATA 205,127, 10, 35, 94, 35, 86,235,221, 33
6 DATA 138,124, 1, 40, 0, 17,120, 0,126,254
7 DATA 65,202, 59,124,221, 25,254, 66,202, 59
8 DATA 124,221, 25,254, 67,202, 59,124,221, 25
9 DATA 254, 68,202, 59,124,221, 25,254, 69,202
10 DATA 59,124,221, 25,254, 70,202, 59,124,221
11 DATA 25, 35,126,254, 78,202, 75,124,221, 9
12 DATA 254, 83,202, 75,124,221, 9, 1, 5, 0
13 DATA 35,126,254, 48,202,129,124,221, 9,254
14 DATA 49,202,129,124,221, 9,254, 50,202,129
15 DATA 124,221, 9,254, 51,202,129,124,221, 9
16 DATA 254, 52,202,129,124,221, 9,254, 53,202
17 DATA 129,124,221, 9,254, 54,202,129,124,221
18 DATA 9,221,102, 4,221,110, 3,195,154, 10
19 DATA 65, 78, 48,146, 7, 65, 78, 49,201, 3
20 DATA 65, 78, 50,228, 1, 65, 78, 51,242, 0
21 DATA 65, 78, 52,121, 0, 65, 78, 53, 60, 0
22 DATA 65, 78, 54, 30, 0, 65, 78, 55, 15, 0
23 DATA 65, 83, 48, 37, 7, 65, 83, 49,146, 3
24 DATA 65, 83, 50,201, 1, 65, 83, 51,228, 0
25 DATA 65, 83, 52,114, 0, 65, 83, 53, 57, 0
26 DATA 65, 83, 54, 28, 0, 65, 83, 55, 14, 0
27 DATA 65, 70, 48,178, 7, 65, 70, 49, 2,
28 DATA 65, 70, 50, 1, 2, 65, 70, 51, 0, 1
29 DATA 65, 70, 52,128, 0, 65, 70, 53, 64, 0
30 DATA 65, 70, 54, 32, 0, 65, 70, 55, 16, 0
31 DATA 66, 78, 48,191, 6, 66, 78, 49, 95, 3
32 DATA 66, 78, 50,175, 1, 66, 78, 51,215, 0
33 DATA 66, 78, 52,107, 0, 66, 78, 53, 53, 0
34 DATA 66, 78, 54, 26, 0, 66, 78, 55, 13, 0
35 DATA 66, 83, 48, 94, 6, 66, 83, 49, 47, 3
36 DATA 66, 83, 50,151, 1, 66, 83, 51,203, 0
37 DATA 66, 83, 52,101, 0, 66, 83, 53, 50, 0
38 DATA 66, 83, 54, 25, 0, 66, 83, 55, 12, 0
39 DATA 66, 70, 48, 37, 7, 66, 70, 49,146, 3
40 DATA 66, 70, 50,201, 1, 66, 70, 51,228, 0
41 DATA 66, 70, 52,114, 0, 66, 70, 53, 57, 0
42 DATA 66, 70, 54, 28, 0, 66, 70, 55, 14, 0
43 DATA 67, 78, 48, 94, 6, 67, 78, 49, 47, 3
44 DATA 67, 78, 50,151, 1, 67, 78, 51,203, 0
45 DATA 67, 78, 52,101, 0, 67, 78, 53, 50, 0
46 DATA 67, 78, 54, 25, 0, 67, 78, 55, 12, 0
47 DATA 67, 83, 48, 2, 6, 67, 83, 49, 1, 3
48 DATA 67, 83, 50,128, 1, 67, 83, 51,192, 0
49 DATA 67, 83, 52, 96, 0, 67, 83, 53, 48, 0
    
```

Program Listing 1 Continues

*"Line 230 determines the AD value.
Integer arithmetic conserves time as
much as possible."*

Program Listing 1 Continues

```

50 DATA 67, 83, 54, 24, 0, 67, 83, 55, 30, 0
51 DATA 67, 70, 48,191, 6, 67, 70, 49, 95, 3
52 DATA 67, 70, 50,175, 1, 67, 70, 51,215, 0
53 DATA 67, 70, 52,107, 0, 67, 70, 53, 53, 0
54 DATA 67, 70, 54, 26, 0, 67, 70, 55, 13, 0
55 DATA 68, 78, 48,172, 5, 68, 78, 49,214, 2
56 DATA 68, 78, 50,107, 1, 68, 78, 51,181, 0
57 DATA 68, 78, 52, 90, 0, 68, 78, 53, 45, 0
58 DATA 68, 78, 54, 22, 0, 68, 78, 55, 30, 0
59 DATA 68, 83, 48, 90, 5, 68, 83, 49,173, 2
60 DATA 68, 83, 50, 86, 1, 68, 83, 51,171, 0
61 DATA 68, 83, 52, 85, 0, 68, 83, 53, 42, 0
62 DATA 68, 83, 54, 21, 0, 68, 83, 55, 30, 0
63 DATA 68, 70, 48, 2, 6, 68, 70, 49, 1, 3
64 DATA 68, 70, 50,128, 1, 68, 70, 51,192, 0
65 DATA 68, 70, 52, 96, 0, 68, 70, 53, 48, 0
66 DATA 68, 70, 54, 24, 0, 68, 70, 55, 30, 0
67 DATA 69, 78, 48, 13, 5, 69, 78, 49,134, 2
68 DATA 69, 78, 50, 67, 1, 69, 78, 51,161, 0
69 DATA 69, 78, 52, 80, 0, 69, 78, 53, 40, 0
70 DATA 69, 78, 54, 20, 0, 69, 78, 55, 30, 0
71 DATA 69, 83, 48,197, 4, 69, 83, 49, 98, 2
72 DATA 69, 83, 50, 49, 1, 69, 83, 51,152, 0
73 DATA 69, 83, 52, 76, 0, 69, 83, 53, 38, 0
74 DATA 69, 83, 54, 19, 0, 69, 83, 55, 30, 0
75 DATA 69, 70, 48, 90, 5, 69, 70, 49,173, 2
76 DATA 69, 70, 50, 86, 1, 69, 70, 51,171, 0
77 DATA 69, 70, 52, 85, 0, 69, 70, 53, 42, 0
78 DATA 69, 70, 54, 21, 0, 69, 70, 55, 30, 0
79 DATA 70, 78, 48,197, 4, 70, 78, 49, 98, 2
80 DATA 70, 78, 50, 49, 1, 70, 78, 51,152, 0
81 DATA 70, 78, 52, 76, 0, 70, 78, 53, 38, 0
82 DATA 70, 78, 54, 19, 0, 70, 78, 55, 30, 0
83 DATA 70, 83, 48,128, 4, 70, 83, 49, 64, 2
84 DATA 70, 83, 50, 32, 1, 70, 83, 51,144, 0
85 DATA 70, 83, 52, 72, 0, 70, 83, 53, 36, 0
86 DATA 70, 83, 54, 18, 0, 70, 83, 55, 30, 0
87 DATA 70, 70, 48, 13, 5, 70, 70, 49,134, 2
88 DATA 70, 70, 50, 67, 1, 70, 70, 51,161, 0
89 DATA 70, 70, 52, 80, 0, 70, 70, 53, 40, 0
90 DATA 70, 70, 54, 20, 0, 70, 70, 55, 30, 0
91 DATA 71, 78, 48, 64, 4, 71, 78, 49, 32, 2
92 DATA 71, 78, 50, 16, 1, 71, 78, 51,136, 0
93 DATA 71, 78, 52, 68, 0, 71, 78, 53, 34, 0
94 DATA 71, 78, 54, 17, 0, 71, 78, 55, 30, 0
95 DATA 71, 83, 48, 2, 4, 71, 83, 49, 1, 2
96 DATA 71, 83, 50, 0, 1, 71, 83, 51,128, 0
97 DATA 71, 83, 52, 64, 0, 71, 83, 53, 32, 0
98 DATA 71, 83, 54, 16, 0, 71, 83, 55, 30, 0
99 DATA 71, 70, 48,128, 4, 71, 70, 49, 64, 2
100 DATA 71, 70, 50, 32, 1, 71, 70, 51,144, 0
101 DATA 71, 70, 52, 72, 0, 71, 70, 53, 36, 0
102 DATA 71, 70, 54, 18, 0, 71, 70, 55, 30, 0
103 DATA 205,127, 10,229, 33,254,127,205, 13, 38
104 DATA 235, 94, 35, 86,225, 14, 1, 27,122,179
105 DATA 19, 40, 6, 62, 3,169, 79,211,255,229
106 DATA 43,124,181, 32,251,225, 27,122,179, 32
107 DATA 238,195,154, 10, 68, 0
110 POKEL6562,123:POKEL6561,253:CLR100:FORZ=31742 TO 32767:REA
D X:S = S+X:POKEZ,X:NEXT
115 IF S=69640 THEN 340 ELSE PRINT"BAD CHECKSUM IN DATA":STOP
120 DEFINTC-Z
130 CLS:G=0:H=0:INPUT"TEMPO 1 TO 20 (1 IS FASTEST)";AP:AT = .2*A
P:RESTORE
140 IF G=0 READ NT$,B ELSE READ NT$
150 RK = B*AT
155 IF LEN(NT$) = 2 OR LEN(NT$)>3 THEN PRINT NT$;" BAD":STOP
160 IF LEN(NT$) = 1 THEN 210
170 C=VARPTR(NT$):POKEL6527,123:POKEL6526,254:P=USR(C)
180 A=1950*B*AT/P+1.1
185 IF A>65535 THEN CLS : PRINT"B*AT PRODUCT";B*AT;"IS TOO LARGE
":STOP

```

Program Listing 1 Continues



TEACH YOUR CHILDREN

ALPHA—Our best seller. Enhanced with larger letters and three exercises. Alphabet recognition for preschoolers.

ALPHA II—More alphabet exercises. Find the duplicate letters; letters before and after; put in alphabetical order.

SIGMA—Addition problems for grades 1-3.

SIGMA-EX—Addition problems for the younger or slower learner.

SIGMA-82—Addition, subtraction, multiplication and division. Nine speed levels. Time left and total time constantly displayed.

SPE-L—Spelling practice for grades 2-4.

Learning to Count Money—A THREE PROGRAM SYSTEM THAT TEACHES THE IMPORTANT SKILL OF COUNTING MONEY. SUPERIOR GRAPHICS. (SOLD BY THE SET ONLY.)

Available on cassette only for TRS-80 Models I and III \$6.95 each, two for \$12.00, four for \$21.00 Learning to Count Money—\$19.95

Add \$1.00 to total order for first class shipment.



Mercer Systems Inc.
87 Scooter Lane
Micksville, N.Y. 11801

GRAPHICS

Graphpac-80 is an easy to use universal Graphics program designed to drive any dot addressable Crt, printer, plotter. Graphpac-80 takes it's data from your disk files and is usable from: Basic, Fortran Pascal, Fourth, Cobol, etc.

Graphpac-80 has these features:

- Circle, Ellipse, Sector, Arc
- Line Relative and Absolute
- 2D and 3D Coordinate Systems
- Character Generation with 360 degrees rotation and size control.
- Over 15 additional commands
- Pie, Bar, Scatter and X, Y Plots
- Maps of the USA and the World
- Various Pictures

Graphpac-80 is available for: TRS-80 Model 1, 2 with 48K and disk, CP/M systems with 48K. Versions already configured for: Epson MX-80 with Graffrax, Calcomp 565 x,y plotter, Matrox ALT 512 5100 Graphics board. TRS-80, \$29.95 CP/M, \$59.95

Call or write:

M.E.S.C.
Parkhurst Drive
Salisbury, MO 21801
301-742-7333

393

GOOD GRIEF !!
THIS IS UNBELIEVABLE!



TOP-NOTCH PROFESSIONAL SOFTWARE FOR THE TRS-80 MODEL II AT LOW PRICES!

- Power enough for the professional programmer
- Easy for the beginner
- Extremely useful

MENU - Program menu generator. Price: \$24.95

- Great way to organize disks, especially hard drives!
- Like having a directory with descriptions and better!
- Ideal front end for an application package
- Displays menu of programs including descriptions
- User selects program with cursor or by line number
- Can run BASIC or TRSDOS compiled programs
- Up to 200 lines in menu including comment lines
- Submenus (other menu files) can be put in menu
- TRSDOS commands can be menu items
- Each disk or program package can have separate menu
- Complete editing facilities including menu "locking"
- Can pass information to selected program through file

RESEQ - Program line renumberer. Price: \$44.95

- No programmer should be without this utility!
- The ideal solution for inserting lines into crowded code!
- Makes structured programming in BASIC easier
- Renumbers all or part of the lines of a program
- Renumbers up to 30 groups of lines at once
- Can copy groups of lines leaving originals
- Can combine groups and renumber them together
- Can relocate a group by adding or subtracting a constant from all line numbers
- Can print table showing old and new line numbers
- Can flag unrenumberable line number references
- Can have separate input and output files
- Works on compressed format files
- SAVE PROG.BAS. A unnecessary!
- Fast - up to 240 lines/minute

CREF - Cross reference generator. Price: \$34.95

- No more worries about accidental misuse of variables!
- Contains features not found in similar utilities elsewhere!
- Complete cross-reference listing of variables, arrays, functions, line number references, and USR routines
- Flags different types of use (line numbers, GOTO, GOSUB, ON ERROR GOTO, RESUME, ERI, FIELD and regular variables, arrays, use modify, define, functions and USR routines, use define)
- Warns when variable may have been used incorrectly
- References listed by effective name and type
- Listing arranged alphabetically or numerically - each type of item in a separate section
- Disk temporary file - no limit on program size
- Works on compressed format files
- Fast - up to 180 lines/minute using Line Printer III

VARLIST - List full names of variables used in program. Price: \$24.95

- When bought with CREF, this is the icing on the cake!
- Lists full names of all variables, arrays, and functions alphabetically. USR routines are listed separately
- Variables having names with same first 2 characters and type are listed together
- Helps find variables with same first 2 characters
- Output listing to CRT, printer, or disk file
- No limit on program size
- Works on compressed format files
- Fast - up to 540 statements/minute on Line Printer III

Introductory offer: Purchase all four packages for only \$99.95!

Note: The above software requires 64K memory to run

For more information: Individual user guides for above packages are available for \$7.50 each, creditable towards purchase of that package if purchased within 90 days

Add \$2.00 for postage and handling
Iowa residents add 5% sales tax

To order call collect (515) 236-8406



World Software Resource
Div. Sumner Enterprises
Hwy. 146 N
Grinnell, IA 50112

376

"... then the program is directed to line 350 for special effects of the piece."

Program Listing 1 Continued

```

190 IF A<32768 THEN D=INT(A) ELSE D=INT(A-65536)
200 PRINTNTS;B,:GOTO310
210 L=VAL(NT$):IF L<>0 THEN 250
220 D=1:CK=5:DK=1953:EK=-6760:IF RK<4 THEN 140 ELSE IF RK<8 THEN
    CK=258:DK=-1253:EK=1668
230 AD=CK*RK*RK+DK*RK+EK
235 IF AD>65535 THEN PRINT"RK VALUE";RK;"IS TOO LARGE":STOP
240 IF AD<32768 THEN P=AD:GOTO 320 ELSE P=AD-65536:GOTO 320
250 IF L=1 AND B<0 THEN 130 ELSE IF L=1 THEN G=1:GOTO 140
260 IF L<>2 THEN 290
270 IF B>0 AND G=0 THEN 350
280 IF H=0 THEN RESTORE:H=1:GOTO 140 ELSE H=0:GOTO 140
290 IF L=3 THEN B=.2*B:GOTO 140 ELSE IF L=4 THEN B=.5*B:GOTO 140
    ELSE IF L=5 THEN B=.8*B:GOTO 140 ELSE IF L=6 THEN G=0:GOTO 140
    ELSE IF L=7 THEN B=1.25*B:GOTO 140 ELSE IF L=8 THEN B=2*B:GOTO 140
    ELSE IF L=9 THEN B=5*B:GOTO 140
300 PRINT"BAD NOTE":STOP
310 POKE16527,127:POKE16526,210
320 F=USR(P):GOTO 140
340 CLS:PRINT"MUSIC GENERATOR READY FOR RUNNING":DELETE1-115
347 'SPECIAL EFFECTS FOR CARMEN MARCH
350 ONBGOTO400
400 N=INT(2*AP):D=16:DR=15:READP1,P2,P3
410 FORZ=1:TON
420 P=P1:F=USR(P):FORZ1=1:TO:DR:NEXT
430 P=P2:F=USR(P):FORZ1=1:TO:DR:NEXT
440 NEXTZ
450 P=P1:F=USR(P):FORZ1=1:TO:DR:NEXT
460 P=P3:F=USR(P):FORZ1=1:TO:DR:NEXT
470 P=P1:F=USR(P):FORZ1=1:TO:DR:NEXT
480 GOTO140
1000 'DATA FOR 'CARMEN MARCH' BY GEORGES BIZET
1010 DATAAN5,8,AN5,2,0,2,AN5,2,0,2,AN5,2,0,2,EN4,2,0,2,DN4,2,0,2
    ,EN4,2,0,2,AN5,8,AN5,2,0,2,AN5,2,0,2,AN5,2,0,2,BN5,2,0,2,CS5,2,0,2
    ,2,BN5,2,0,2,AN5,4,0,4,AN5,2,0,2,AN5,2,0,2,BN5,2,0,2,AN5,2,0,2,G
    S4,2,0,2,AN5,2,0,2,2,1,53,48,57
1020 DATADN5,4,0,4,DN5,2,0,2,DN5,2,0,2,DN5,2,0,2,AN5,2,0,2,GN4,2
    ,0,2,AN5,2,0,2,DN5,4,0,4,DN5,2,0,2,DN5,2,0,2,DN5,2,0,2,EN5,2,0,2
    ,FS5,2,0,2,EN5,2,0,2,DN5,4,0,4,DN5,2,0,2,CS5,2,0,2,BN5,4,0,4,BN5
    ,2,0,2,AN5,2,0,2,2,1,64,60,72
1030 DATAAN5,4,0,4,AN5,2,0,2,AN5,2,0,2,EN4,2,0,2,DN4,2
    ,0,2,EN4,2,0,2,AN5,4,0,4,AN5,2,0,2,AN5,2,0,2,AN5,2,0,2,BN5,2,0,2
    ,CS5,2,0,2,BN5,2,0,2,AN5,4,0,4,AN5,2,0,2,AN5,2,0,2,BN5,2,0,2,AN5
    ,2,0,2,GS4,2,0,2,AN5,2,0,2
1035 DATA2,1,53,48,57
1040 DATAEN5,4,0,4,EN5,2,0,2,EN5,2,0,2,EN5,4,DN5,4,CS5,2,0,2,DN5
    ,2,0,2,EN5,4,0,4,EN5,2,0,2,EN5,2,0,2,EN5,4,DN5,4,CS5,2,0,2,DN5,2
    ,0,2,EN5,8,EN4,4,FS4,4,GS4,8,EN4,4,CS5,4,BN5,16,AN5,8,0,8,2,0
1050 DATACS4,4,0,4,FS4,4,0,4,CS4,4,0,4,BN4,4,0,4,AN4,8,GS3,4,PS3
    ,4,GS3,4,0,4,CS3,4,0,4,FS3,8,GS3,8,AN4,8,CS4,8,ES4,8,DS4,4,ES4,4
    ,CS4,4,0,4,CS4,4,0,4
1060 DATACS4,8,FS4,4,0,4,CS4,4,0,4,BN4,4,0,4,AN4,8,GS3,4,PS3,4,G
    S3,4,0,4,CS3,4,0,4,FS3,4,0,4,GS3,4,0,4,AN4,4,0,4,CS4,4,0,4,ES4,8
    ,DS4,4,ES4,4,CS4,8,0,8
1070 DATADN5,4,DN5,4,DN5,4,0,4,EN5,4,EN5,4,EN5,4,0,4,FS5,4,FS5,4
    ,FS5,4,0,4,DN5,4,DN5,4,DN5,4,0,4,CS5,4,0,4,GS4,4,0,4,CS5,4,0,4,D
    N5,4,0,4,CS5,4,0,4,GS4,4,0,4,CS5,4,0,4,0,8,DN5,4,DN5,4,DN5,4,0,4
    ,EN5,4,EN5,4,EN5,4,0,4
1075 DATAFS5,4,FS5,4,FS5,4,0,4,DN5,4,DN5,4,DN5,4,0,4
1080 DATAGS2,4,GS4,2,GS5,2,GS1,4,GS4,2,GS5,2,AN2,4,GS4,2,GS5,2,A
    N3,4,GS4,2,GS5,2,AS3,4,GS4,2,GS5,2,AS2,4,GS4,2,GS5,2,BN2,4,GS4,2
    ,GS5,2,BN3,4,GS4,2,GS5,2,BS3,4,GS4,2,GS5,2,BS4,4,GS4,2,GS5,2,CS2
    ,4,GS4,2,GS5,2,CS3,4,GS4,2,GS5,2
1085 DATADN5,4,GS4,2,GS5,2,GS4,4,0,4,GS4,4,0,4,AN5,4,0,4,AN5,2,0
    ,2,AN5,2,0,2,AN5,2,0,2,EN4,2,0,2,DN4,2,0,2,EN4,2,0,2,AN5,4,0,4,A
    N5,2,0,2,AN5,2,0,2,AN5,2,0,2,BN5,2,0,2,CS5,2,0,2,BN5,2,0,2,AN5,4
    ,0,4,AN5,2,0,2,AN5,2,0,2,BN5,2,0,2
1087 DATAAN5,2,0,2,GS4,2,0,2,AN5,2,0,2
1090 DATA2,1,53,48,57,DN5,4,0,4,DN5,2,0,2,DN5,2,0,2,DN5,2,0,2,AN
    5,2,0,2,GN4,2,0,2,AN5,2,0,2,AN5,2,0,2,AN5,4,0,4,AN5,2,0,2,AN5,2,
    0,2,EN5,2,0,2,FS5,2,0,2,EN5,2,0,2,AN5,4,0,4,AN5,2,0,2,CS5,2,0,2,
    BN5,4,0,4,BN5,2,0,2,AN5,2,0,2

```

Program Listing 1 Continues



Rose

You've Got TOTAL ACCESS

(specializing in TRS80™)

TO YOUR COMPUTER HARDWARE & SOFTWARE NEEDS. CALL ROSE TODAY!

The complete line of Radio Shack products is available through TA with standard RS limited warranty. Call me for price and delivery. Just cause you don't see it don't mean we ain't got it. ROSE

I've got

★ DISK DRIVES

TA400 (40-T).....	\$289
TAB00 (80-T).....	\$399
TA400 Flippy.....	\$319
TAB00 Flippy.....	\$409
TA400-2 Dual Head.....	\$409
TAB00-2 Dual Head.....	\$549

Complete with silver enclosure & power supply.

All TA Drives are MPI.

★ CABLES

2-Drive.....	\$23.95
4-Drive.....	\$33.95
Extender Cable.....	\$14.95

★ BARE DRIVES

TA400B.....	\$249
TAB00B.....	\$349
TA400B Flippy.....	\$269
TAB00B Flippy.....	\$359

★ EPSON PRINTERS

MX80.....	\$469.00
MX80 F/T.....	\$579.00
MX100.....	\$769.00
Parallel Cables.....	\$24.95
MX 70-80 Ribbons.....	\$12.95

★ OPERATING SYSTEMS

TRSDOS 2.3 Disk & Manual.....	\$19.95
LDOS.....	\$119.95
NEWDOS/80.....	\$129.95
DOSPLUS 3.3,3.3D.....	\$89.95

★ IRON

Disk Drive Power Supply, Single.....	\$37
Disk Drive Case (silver) and Base	\$19
Memorex Diskettes (bx of 10).....	\$25

90 day warranty on DRIVES. Add \$5.00 freight per drive in Cont. U.S. UPS COD charge \$1.50. There is also a 15 day FREE TRIAL on TA drives. If not completely satisfied I'll refund your money (less shipping). I'll take exception to improper use or mishandling.

★ RADIO SHACK COMPUTERS

26-1061 MIII, LI, 4K.....	\$595
26-1062 MIII, LII, 16K.....	\$835
26-1065 MIII, 48K, 1 Drive.....	\$1695
26-1066 MIII, 48K-2 Dr-RS232.....	\$2099
26-3001 4K Color Computer.....	\$315
26-3002 16K w/ext. Basic.....	\$485
26-3003 32K w/ext. Basic.....	\$566
26-3501 Pocket Computer.....	\$185
26-4002 MII, 64K, 1-dr.....	\$3288

★ PERIPHERALS - Model I, II, III

26-1140 OK Exp. Interface.....	\$249
26-1140 With 16K Mem. Tstd/Guar.....	\$299
26-1140 With 32K Mem. Tstd/Guar.....	\$349
26-1145 MII RS232 w/cable.....	\$85
26-1148 MIII RS232 w/cable.....	\$89
26-1172 D.C. Modem I.....	\$135
26-1173 D.C. Modem II.....	\$169
26-1206 CTR-80 Recorder.....	\$51
26-3008 CC Joysticks, pr.....	\$21
26-3010 13" Color Video.....	\$353
26-4150 MII 8.4MB Disk.....	\$3820
26-4151 MII Hard Disk No.2.....	\$2970
16K 200nsec Memory Guar 1yr.....	\$29

★ OTHER PRINTERS & ACCESSORIES

26-1158 Daisy Wheel II.....	\$1694
26-1455 Acoustic Cover.....	\$339
26-1447 Tractor Assy.....	\$208
26-1448 Sheet Feeder.....	\$1111
26-1165 Line Printer V.....	\$1581
26-1166 Line Printer VI.....	\$986
26-1167 Line Printer VII.....	\$339
26-1168 Line Printer VIII.....	\$679
26-1191 Flat Bed Plotter.....	\$1695
26-1195 Digitizer.....	\$379
ANADEx DP-9500, 9501.....	\$1295
NEC 7730 Spinwriter, 55cps.....	\$2484
Daisy Wheel Printer, 45cps.....	\$1779
Tractor for above.....	\$237
Sheet Feeder for above.....	\$1250
26-1308 Printer Stand.....	\$88
26-4302 Printer Stand.....	\$129
26-1401 or 4401 Printer Cable.....	\$32

★ NEC COMPUTERS

PC-8001A Keyboard & Processor.....	\$1099
PC8011A Expansion Unit.....	\$699
PC-8031A 2-drive Expansion Unit.....	\$1093
PC-8041A Green Phos. Video.....	\$225
PC-8043A HighRes Color Mon.....	\$925

ZENITH MONITORS

12" Screen * Green Phosphor
This is the one you have been waiting for. Well built, works great with the model I. Also has 40/80 column switch so the Apple folks can use it. 90 day warranty good Nationwide. Sell your old Model I monitor and be the first on your block to have a "real" green screen.
12" Zenith Green Phos. Mon..... \$135
Cable for Model I..... \$7

★ RADIO SHACK SOFTWARE

I have most all R/S software instock and it can be yours at 15% off the R/S retail price. Call me for the latest availability.

DOUBLE DENSITY DATA SEPARATOR FROM AEROCOMP \$49.95

If you own a PERCOM DOUBLER A * DOUBLER II * or ENDoupler ** upgrade it with the DDS Plug right in. No more lock-out! You deserve one of these.

ORDER NOW! TOLL FREE 800-527-3582

Write or call ROSE TOLL FREE at 1-800-527-3582. Texas residents call 214-234-1770. Please use the toll free lines for orders and literature requests only. Technical help or service use the Texas line. Prices are mail order only. You pay by VISA or MASTERCARD, you can send check or money order (allow a couple of weeks for personal checks to clear) or order COD (we ship COD'S cash, certified check or money order only). 25% deposit required on all COD orders. Rose will take American money in just about any form. Add freight (UPS where possible) on all orders. Texas residents cough up 5% sales tax. Allow 2-4 weeks for delivery. Order today - I need the money!

TOTAL ACCESS P.O. BOX 3002 RICHARDSON, TX 75080

214-234-1770

ROSE'S SPECIAL OF THE MONTH

★ AEROCOMP'S ★ ALL NEW DOUBLE DENSITY CONTROLLER

"DDC" \$149.95

Here's a Double Density Controller for Mod. 1 that does away with all those data separation problems that seem to keep cropping up! Rose wouldn't fun ya now, would she? Don't be scared of Double Density any more. AEROCOMP has designed some advanced circuitry that even I don't understand - but I do know it works. Better order now. Quantities are going to be a bit short.

\$189.95 complete with Dosplus 3.3D. How many do you want? 12?

* Trademark of PERCOM DATA CO. ** Trademark of LNW * TRS80 & Radio Shack are trademarks of Tandy Corp. Copyright 1981 TOTAL ACCESS

“... use two quarter rests or four eighths... A whole rest will probably never make it.”

pens, use two quarter rests or four eighths rests for a half rest. A whole rest will probably never make it. Line 235 is among the three lines to be deleted after the music data are debugged.

Line 240 converts the AD value to the P integer that the machine language interprets

as a period for playing rests.

Lines 250-300 treat all cases where L (the integer value of NT\$) is not zero. In line 250 an L of one ends the piece, provided it is accompanied by a negative B-value. If B is any number greater than zero, the program returns to line 140 with that fixed B-value

and G is set to read only NT\$.

Lines 270 and 280 treat cases of L equals two. If B is positive and is read with NT\$ then the program is directed to line 350 for special effects of the piece with the B-value used for further direction at line 350. If B equals zero then a repeat functions at line

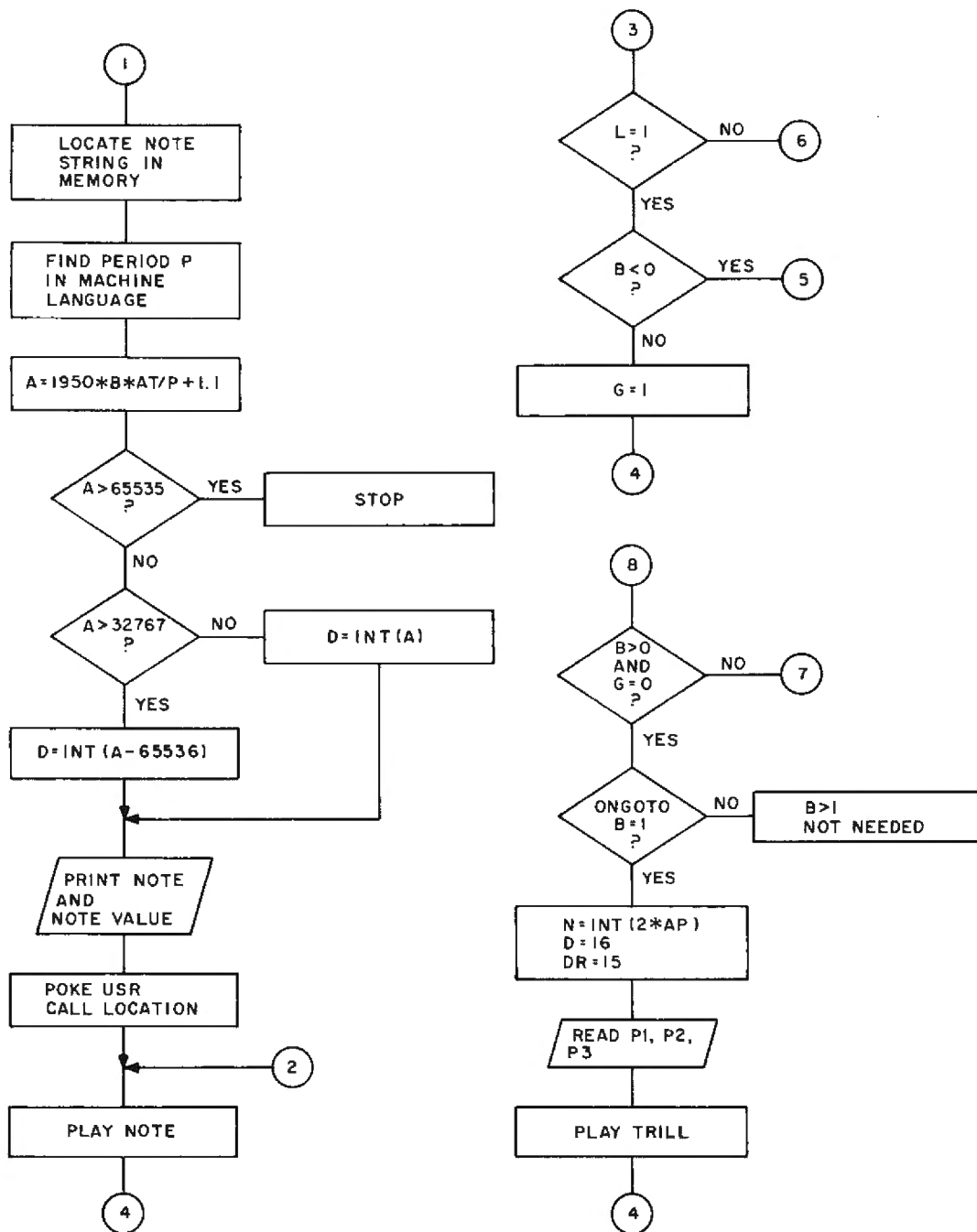

Fig. 2b

Level IV Products, Inc. Is Expanding Again! 3 Locations To Serve You...

<p>HEADQUARTERS DIVISION 32429 Schoolcraft Road Livonia, Michigan 48150 313 / 525-6200</p>	<p>LEVEL IV COMPUTER CENTER 182 North 20th Street Battle Creek, Michigan 49015 616 / 963-2212</p>	<p>RADIO SHACK* DEALER STORE #P-130 134 South Front Dowagiac, Michigan 49047 616 / 782-6600</p>
---	--	--

Our Purchasing Power, (\$5 Million plus Gross Sales) allows us to offer the best of RADIO SHACK*, as well as other popular Hardware and Software at the **LOWEST DISCOUNT PRICES AVAILABLE!**

OUR POLICY IS THAT IF WE SELL IT...WE ALSO SERVICE IT!
CALL US TOLL FREE IF YOU DON'T SEE THE ITEM YOU'RE LOOKING FOR.

TYPICAL PRICES (PARTIAL LISTING)

TRS 80* Color Computer, 32K w/ext. Bas.....	499.00
TRS 80* Mod III, 48K w/1-40 TR Drive.....	1589.00
TRS 80* MOD II, 64K w/1-8" Drive.....	3375.00
TRS 80* MOD 16, 128K w/1-Double 8" Drive.....	CALL
TRS 80* MOD III, 6.4MEG Winchester Drive.....	2795.00
5¼" Add on Drives for MOD I, III, Color, etc.....	from 228.00
8" Add on Drives for MOD II, MOD 16.....	from 540.00
Printers, Radio Shack*, Epson, Citoh, etc.....	CALL
Technical Service (7 technicians on staff).....	24.00/hour
UPGRADE YOUR PRESENT COMPUTER.....	CALL FOR A QUOTE!

WARRANTY POLICY:

The Radio Shack* 90 Day Warranty requires construction from Radio Shack* Supplied components, at slightly higher prices.

Equipment containing non-R/S components is covered by our 6 month parts and labor warranty.

Inquire when ordering to ascertain your coverage.

TERMS OF SALE:

We allow a 2% discount for cash pre-paid orders, personal checks require 2 weeks for bank clearance.

VISA, Master Charge and C.O.D. orders accepted, deposits are required for all special order and assembly items.

SHIPPING:

Foreign orders and large items shipped best-way freight collect, most others are shipped promptly

from stock via U.P.S. add 1.5% or \$2.50 minimum, and \$1.50 if C.O.D.

DEALER'S NOTE: Some key areas are still available for both re-sale and servicing dealerships, contact our Headquarters Division for Details.

**TOLL FREE ORDER HOT LINE
800-521-3305**

**HARDWARE/SOFTWARE
Service Line
313 / 525-6200**

Your One Stop Computer Shopping Center

*TRADE MARK OF TANDY CORPORATION



"More than one repeat could be programmed but complexities interrupt music continuity."

Program Listing 2 Continued

```

1095 DATA2,1,64,60,72,AN5,4,0,4,AN5,2,0,2,AN5,2,0,2,AN5,2,0,2,EN
4,2,0,2,DN4,2,0,2,EN4,2,0,2
1100 DATAAN5,4,0,4,AN5,2,0,2,AN5,2,0,2,AN5,2,0,2,BN5,2,0,2,CS5,2
,0,2,BN5,2,0,2,AN5,4,0,4,AN5,2,0,2,AN5,2,0,2,AN5,2,0,2,BN5,2,0,2,AN5,2,0,2
,GS4,2,0,2,AN5,2,0,2
1110 DATA2,1,53,48,57,EN5,4,0,4,EN5,2,0,2,EN5,2,0,2,EN5,2,0,2,DN
5,2,0,2,CS5,2,0,2,DN5,2,0,2,EN5,4,0,4,EN5,2,0,2,EN5,2,0,2,EN5,2,
0,2,DN5,2,0,2,CS5,2,0,2,DN5,2,0,2
1120 DATAEN5,8,EN4,4,FS4,4,GS4,8,EN4,4,CS5,4,DN4,1,EN4,1,GS4,1,B
N5,13,AN5,4,0,12,FN3,4,0,4,FN3,2,0,2,FN3,2,0,2,FN3,2,0,2,CN3,2,0
,2,BF3,2,0,2,CN3,2,0,2,FN3,4,0,4,FN3,2,0,2,FN3,2,0,2,FN3,2,0,2,G
N3,2,0,2,AN4,2,0,2,CN3,2,0,2
1125 DATAFN3,4,0,4,FN3,2,0,2,FN3,2,0,2,FN3,2,0,2,CN3,2,0,2,BF3,2
,0,2,CN3,2,0,2,FN3,16,FN3,8,0,8
1130 DATAEP4,4,0,4,EP4,2,0,2,EP4,2,0,2,EP4,2,0,2,BF4,2,0,2,AF4,2
,0,2,BA4,2,0,2,EP4,8,EP4,4,EP4,4,EP4,4,FN4,4,GN4,4,FN4,4,EP4,8,E
F4,4,EP4,4,EP4,4,BF4,4,AF4,4,BF4,4,EP4,16,EP4,8,0,8,DF5,4,0,4,DF
5,2,0,2,DF5,2,0,2,DF5,2,0,2
1135 DATAAP5,2,0,2,GF4,2,0,2,AF5,2,0,2
1140 DATADP5,4,0,4,DF5,2,0,2,DF5,2,0,2,DF5,2,0,2,EF5,2,0,2,FN5,2
,0,2,EF5,2,0,2,DF5,8,DF5,4,DF5,4,DF5,4,AF5,4,GF4,4,AF5,4,DF5,16,
DF5,8,0,8,BN4,4,0,4,BN4,2,0,2,BN4,2,0,2,BN4,2,0,2,FN3,2,0,2,EN3
,2,0,2,FN3,2,0,2
1145 DATABN4,4,0,4,BN4,2,0,2,BN4,2,0,2,BN4,2,0,2,CS4,2,0,2,DS4,2
,0,2,CS4,2,0,2,BN4,4,0,4,BN4,2,0,2,BN4,2,0,2,BN4,2,0,2,FN3,2,0,2,
EN3,2,0,2,FN3,2,0,2
1150 DATABN4,16,BN4,8,0,8,EN3,21.33,EN3,5.33,EN3,5.33,DN3,21.33,
DN3,5.33,DN3,5.33,CS3,21.33,CS3,5.33,CS3,5.33,BN3,21.33,BN3,5.33
,BN3,5.33,EN4,16,FS4,12,EN4,4,CS4,16,CS4,16
1160 DATACS4,12,BN4,4,CS4,12,DN4,4,CS4,24,0,8,DN4,16,BN4,12,EN4,
4,CS4,32,AN4,16,FS3,12,BN4,4,EN3,24,0,4,BN4,16,BN4,12,BN4,4,BN4,
8,FS4,8,EN4,8,DN4,8
1170 DATACS4,8,BN4,8,CS4,8,DN4,8,CS4,24,0,8,GS4,16,CS4,12,CS4,4,
CS4,16,BS4,12,DS4,4,GS4,16,ES2,8,0,8,GS2,8,0,8,CS2,8,0,8,BN3,8,F
S4,2.67,GS4,2.67,FS4,2.67,ES4,8,FS4,8
1180 DATABN4,8,CS4,8,DN4,16,EN2,8,CS4,2.67,DN4,2.67,CS4,2.67,AN4
,8,FS4,8,EN4,8,CS5,2.67,DN5,2.67,CS5,2.67,AN5,8,FS5,8,EN5,8,AN5,
2.67,BN5,2.67,AN5,2.67,EN4,8,DN5,8,CS5,16,BN5,16,1,2,AN5,0,0,0,A
N5,0,AN5,0,AN5,0,EN4,0,DN4,0,EN4,0
1190 DATAAN5,0,0,0,AN5,0,AN5,0,AN5,0,AN5,0,AN5,0,AN5,0,AN5,0,0,0
,AN5,0,AN5,0,AN5,0,EN4,0,DN4,0,EN4,0,AN5,0,AN5,0,AN5,0,AN5,0
,BN5,0,CS5,0,BN5,0,AN5,0,EN4,0,DN4,0,EN4,0,AN5,0,BN5,0,CS5,0,BN5
,0,AN5,0,EN4,0,DN4,0,EN4,0,AN5,0
1195 DATABN5,0,CS5,0,BN5,0
1200 DATAAN5,0,BN5,0,CS5,0,BN5,0,AN5,0,BN5,0,CS5,0,BN5,0,AN5,0,B
N5,0,CS5,0,BN5,0,AN5,0,BN5,0,CS5,0,BN5,0,AN6,EN2,AN3,EN2,AN6,AN3
,AN6,AN3,AN6,AN3,EN5,AN3,DN5,AN3,EN5,AN3,CS5,EN2,AN3,EN2,EN5,AN3
,EN5,AN3,EN5,AN3,CS5,AN3,BN5,AN3,CS5,AN3
1210 DATAAN5,EN2,AN3,EN2,CS5,AN3,CS5,AN3,CS5,AN3,AN5,AN3,GS4,AN3
,AN5,AN3,EN4,AN3,AN5,AN3,DN4,AN3,EN4,AN3,CS4,AN3,EN4,AN3,BN4,AN3
,CS4,AN3
1215 DATA6,AN4,8,0,4,AN5,4,AN5,8,0,4,AN5,4,AN5,8,0,4,AN5,4,AN5,8
,0,4,AN5,4,AN2,2,AN3,2,AN4,2,AN5,42
1220 DATA1,-1

```

280 by setting the H flag and restoring the data to the beginning of the piece. More than one repeat could be programmed but the complexities make it impossible to avoid a long interruption in music continuity. If you wish additional repeats, you must retype the data into the program.

Line 290 deals with L-values from 3-9. They are used only when G equals one and no B-values are being read. L-values from 3-5 shortens B from .2x to .8x. L-values from 7-9 correspondingly lengthens B from 1.25x to 5x. Pair L-values of five with seven, of four with eight, and of three with nine to return to the original B. Use these three L's for time shadings when G equals one. If you wish to return to paired readings with B accompanying the note and are reading only the note, put L equals six in the data to set G to zero.

If you wish time shadings when G equals zero such as for ritard and accelerando, B-values can be varied by fractional amounts. Increase B to slow the music and decrease B to speed it up. Time shadings that alter the tempo AT are more difficult as they require small program changes. You may insert, for example, after the G equals 1 in line 250 an "AT = 1.25*AP" before going to note reading with a fixed B. But be sure to insert an "AT = .2*AP" following the G = 0 in line 290 if you wish to return to the original tempo with note paired with B readings.

The "Carmen March"

Lines 350 through 1220 are special for the "Carmen March" by George Bizet. This number illustrates many of the program's capabilities. Line 350 is reached by an NT\$ equals two and B equals one reading of data from line 270. A B-value of one directs the program to line 400 for a special effect of trilling. Other special effects might be added in lines 500-999 for glissando, shakes, or the like by B-values of two or above in line 350. Only trills are used in the "Carmen March" and therefore only lines 400-480 are used.

Line 400 sets N to define the length of the trill as a function of the tempo at which you wish to play the piece. D is then set at 16. The machine language must have a D to function and I found 16 to be acceptable for trills. A DR-value is then set for the very short interval of silence between notes of the trill. If you wish to vary the duration of the trill you may change the DR-value from the value of 15 or change the constant in the equation $N = INT(2*AP)$. Finally, the periods of three notes (P1, P2, and P3) that perform

Program Listing 2

```

1 'MUSIC DRIVER V10 FOR MUSIC KEYBOARD AT 7A68H AND MUSIC GENERA
TOR AT 7PBDH
2 'PROGRAM FOR TRS-80 MODEL I LEVEL II 16K
3 ' BY MERTON L. AVIS
4 ' 3A PALMETTO ARMS
5 ' CAMDEN S. CAROLINA 29020
6 'RUN FIRST TO LOAD KEYBOARD AND MUSIC GENERATOR
7 'THEN RUN TO PLAY MUSIC AT TEMPO OF YOUR CHOICE
8 '
9 DATA 205,127, 10,229, 33, 32,123,205, 13, 38

```

Program Listing 2 Continues

A Computer That Writes Programs For You.

What will they think of next..?

Your computer is fantastically fast...once it knows what to do. You probably realize that a computer is really the combination of hardware and software, working together smoothly, to give you what you want. Either one alone is useless. Software is really the key...the "mind" of a computer system. Every project or task you want to do requires a new specific software application to make it behave exactly the way you desire.

Of course, you may be able to "force-fit" an application into some existing canned program you have, but to really get results, you need a separate application program to run on your computer.

Until now, that meant you were forced to pay money for application software off the shelf, or if you could afford it, have it custom written for you, or, if you are qualified, do it yourself...spending endless hours figuring it out and writing it. Now, your computer can write individual application programs for you. These programs are each separate, unique software programs that run in standard Basic on your computer.

A company named FutureSoft has developed this exciting and long awaited remarkable working tool for you. There are two versions called *Quikpro+Plus* and standard *Quikpro*. Both of them create unique separate Basic programs for you...to do exactly, precisely, what you want to do. And listen to this...you create a new program in minutes instead of hours.

You can quickly generate a new program when you want it. You can generate thousands of different unique programs, each one standing alone as a complete program that runs in Basic. Best of all, you do not have to be a programmer to do it. The *Quikpro* software becomes your personal programmer, waiting to do your work for you any time of day or night you choose to use it.

The custom programs you generate from this software provide for: Data Entry, Additions, Changes, Record Locating & Searches, great variety of Computations, and Report Printing (if you have a printer). It lets you decide what data to manipulate and how to manipulate it. It lets you decide the formats you want to appear on your screen and/or to print out in a report. It lets you use differing formats on the same data base. It lets you make calculations from data within records without altering the data base. It lets you report results with or without including the base data from which results were calculated.

All this is included in the ability/power of the program you create. You do it by simply answering questions that appear on your screen. Instantly, the *Quikpro* software instructs the computer to perform complex and

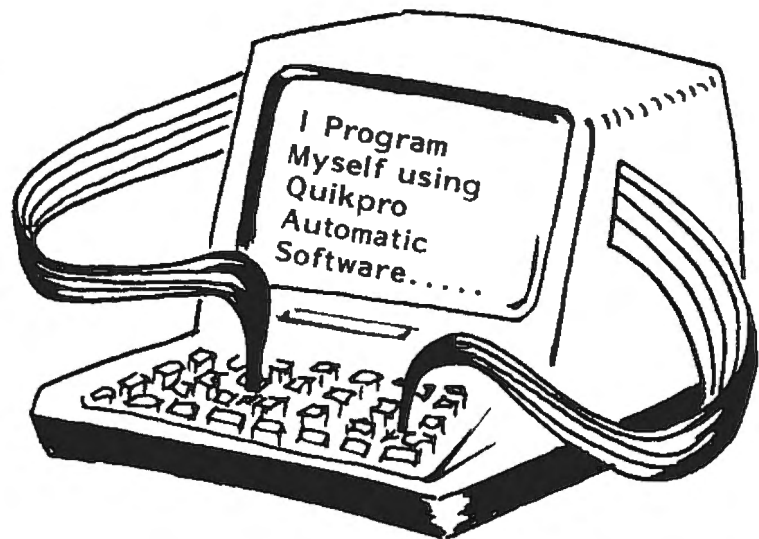

error free instructional sequences. You get the immediate benefits of professionally written software for your application.

The resulting custom program is truly a separate Basic program. You can list it, you can modify it, you can actually see what makes it tick. You can even ask it to print out its own operating instruction manual so others can run it for you. Finally, you can really tap the speed and power of your computer the way you really want. You can create new programs for every use you have in Business, Science, Education, and Hobby areas. And you can start now.

The software is available immediately from the creators. It comes in two versions. If you want to generate separate Basic programs with all the data handling plus Calculations and Report Printing features, you want *Quikpro+Plus*. Specify to run on TRS80 Model I and Model III at only \$149; to run on TRS80 Model II at \$189.

If you do not need Calculation ability or Report Printing in the separate Basic programs you will create from this program generating software, then standard *Quikpro* will do the job for you. Standard *Quikpro* to run on TRS80 Model I or Model III is \$89; to run on TRS80 Model II is \$129. (Later on you can always trade up to the Plus Versions for only the cost difference between the two).

Both programs are available to run on many other computers besides TRS80. Details are available by calling or writing.

You can order right now by phone or mail. If you have Visa/Mastercard, call toll-free from:

All States except CA-AL-HI	1-800-824-7888 OP# 441
From California call	1-800-852-7777 Op# 441
From Alaska/Hawaii call	1-800-824-7919 Op# 441

Operators on duty 24 hours daily. Operators can not answer technical questions. If you need technical information or want to order from Canada or other nations, call 1-904-269-1918 during office hours, Eastern Time, Mon.-Fri.

Send mail orders with check, money order or credit card information to: FutureSoft, P.O. Box 1446-D, Orange Park, Florida 32073. FutureSoft gives you a satisfaction or your money refunded guarantee for 10 days from delivery. You can run the software yourself on your own computer and see with your own eyes what it can do for you. Order now. ✓66

THE ULTIMATE CHECKBOOK

The Ultimate Checkbook is designed to help the individual keep track of checks, tax deductions, and deposits as well as provide for fast and easy checkbook balancing and bank reconciliation. However, its versatility is such that it can be used effectively as a "Mini-Ledger" for many small businesses.

FEATURES: ✓ 309

- Menu driven for easy use
- Checks can be entered, edited, and deleted quickly
- In-memory check capacity of approximately 400 checks
- Check listings on screen or your printer
- Running balance displayed when posting checks
- Defaults for check numbers and date to speed data entry
- Check-by-check balance displayed or printed
- Defaults for check numbers and date to speed data entry
- Search routine finds checks quickly and easily
- Fast MACHINE LANGUAGE, multi-key sort
- Totals checks and deposits by deduction, budget, or deposit categories

System Requirements: TRS-80 Models I & III with 48K, DOS & Printer (Optional). Please indicate model when ordering \$39.95. Please add \$2 for handling and postage, \$5 overseas. For your convenience you may phone in VISA or M/C orders.

SOFTWAREHOUSE INTERNATIONAL
We've Moved! P.O. Box 1383 Tandy Corp.
Clovis, CA 93613; (209) 251-7877

GET YOUR TRS-80 DIRECT FROM

AUTHORIZED SALES CENTER

FORT WORTH COMPUTERS AND VIDEO

377 PLAZA, HWY 377 GRANBURY FORT WORTH, TX 76048 ✓214

AND SAVE \$

FREE! Zenith Color TV, NEW 1982 Model, with every MOD II or equivalent.

Get our quote "before" you buy. Full manufacturers' warranty. Texas residents add 4% sales tax.

817-573-4111

COST OF CALL REFUNDED FOR ORDERS BY TELEPHONE

Maxell Floppy Disks

The Mini-Disks with maximum quality.



Dealer inquiries invited. C.O.D.'s accepted. Call FREE (800) 235-4137.

PACIFIC EXCHANGES
100 Foothill Blvd., San Luis San Luis Obispo, CA 93401
In Cal. call (800) 592-5935 or (805) 543-1037

✓ 207

"For normal staccato give 1/2 the B value... the other half with a rest of equal B value."

the trill are read. The periods are read directly rather than going to the machine language so not to require POKEing the location of the USR into memory. The values to use for P1, P2, and P3 are listed in the

Assembly code of Program Listing 2 under the Table of Notes. This table is structured such that three bytes for the note string are followed by two bytes for the note period. Every note and corresponding period from AN0 to CN7 is listed.

After P1 through P3 are read, lines 410 through 440 plays the main section of the trill. The finishing grace is accomplished in lines 450 through 470. Finally, the program returns to line 140 for the next note to play.

The data for the music starts in line 1010. I use 10 line numbers of data for each line of music. In this way, line 1210 tells me that there are 21 lines of music in the "Carmen March." If this information is used in conjunction with the printing in line 200, debugging the data should be eased.

The music data starts in line 1010 with an eighth note played at AN5 as shown by the AN5,8 combination. Next comes a series of sixteenth notes played staccato. For normal staccato give the note 1/2 the regular B-value (a 32nd note value in this case) and take up the other half with a rest of equal B-value. The ratio may be varied from 1/4 to 3/4 or 3/4 to 1/4 depending on the sharpness of the staccato desired. A full B-value plays the note a good legato. Later in line 1010, AN5,4,0,4 shows an eighth note played staccato.

Line 1010 also has an example of data producing a trill. The sequence at the end of the line ("2,1,53,48,57") sends the program to line 400 where a trill is played with three notes having periods of 53, 48, and 57.

Line 1040 contains an example of a repeat. The 2,0 combination after the eighth rest at the end of line 1040 starts the music from the beginning. When the music again reaches the 2,0, it continues on with data from line 1050.

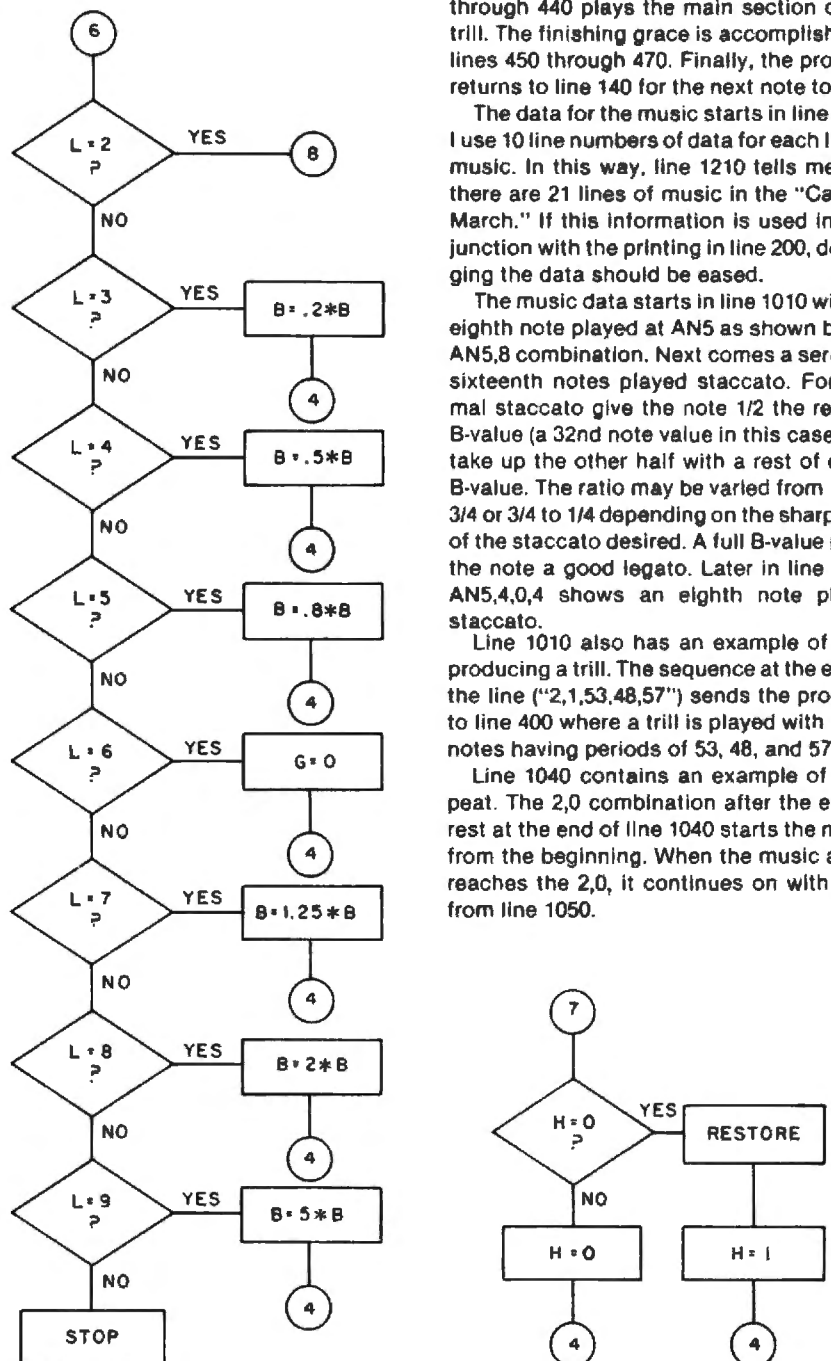

Fig. 2c

Your best Model I/III peripheral buy is a modem.

Considering expanding your TRS-80 Model I or III? Then you should know that **only one kind of peripheral** can give you all these **extra capabilities** . . . in a single unit:

- **Computer-to-computer data communications, for better personal or business management.**
- **Access to free "bulletin board" resources.**
- **Access to Source, CompuServe and other time-sharing systems.**
- **Services like electronic mail, instant news and financial reports.**
- **An almost limitless supply of new games and other enthusiast activities.**

Of course, we're talking about a modem. A far more **sensible** first step in expanding than, say, joysticks, or a voice box, or a printer. And, therefore, your **best peripheral buy**.

A modem opens up a whole new world to you. A world of **thousands of computers** and computer people just like you, in homes and businesses around the block and across the country. A world you tap through your telephone.

But don't simply settle for any modem. For the most modem satisfaction, you need to make the **best modem buy**.

And that's **LYNX**.



Lynx for Model I/III.

The new LYNX for TRS-80 Model I and Model III. It's the latest innovation from the people who are making data communications affordable. It's the best first step you can take in expanding. It makes your microcomputer a whole new animal.

Your best Model I/III modem buy is LYNX.

The new LYNX is the ideal modem for your Model I or III. That's because it's the **key element** of a **total direct-connect telephone communications package**.

This package includes all serial and computer bus interfaces, cables and terminal software . . . and comes to you with these remarkable features:

- **SINGLE PRICE: \$299.95!**
- **Compatible with both Model I and III.**
- **No separate purchases required.**
- **One-year warranty.**
- **Auto dial/auto answer.**
- **Works with any software, including ST-80 by Micklus.**
- **Active clear, break, and "control" keys.**
- **Half or full duplex, variable word length, parity and stop bits.**
- **Dial from phone, keyboard, or memory.**
- **Works with or without Model I expansion interface.**
- **Works with or without Model III RS-232 card.**
- **Can be placed on either side of Model III.**
- **No tools needed to install.**

No other modem gives you so much in a **single package**. And when you **compare** the LYNX price with the **total cost** of bringing any other modem on line, it could **save you OVER \$100!**

ESILYNX

123 LOCUST STREET LANCASTER, PENNSYLVANIA 17602
Phone 717/291-1116

TRS-80 is a trademark of the Radio Shack Division of Tandy Corporation.
FCC Registration Number: A909KE-68171-DM-N

✓ 49



Consult your local microcomputer retailer, or call one of these LYNX handlers today.

THE BOTTOM LINE
Milford, NH
800/343-0726

B. T. ENTERPRISES
Centereach, NY
516/981-8568

BREEZE/QSD
Dallas, TX
214/484-2976

COMPUTER PLUS
Littleton, MA
800/343-8124

THE PROGRAM STORE
Washington, DC
800/424-2738

STEVENS RADIO SHACK
Phoenixville, PA
800/345-6279

SIMUTEK
Tucson, AZ
800/528-1149

PROGRAMS UNLIMITED
Jericho, NY
800/645-6038

"The arpeggio notes of a chord may be given any B value from .06 to two. . ."

Program Listing 2 Continued

```

10 DATA 235, 94, 35, 86,225,122,179,202,212,127
11 DATA 35, 94, 35, 86,213,253,225,221, 33, 37
12 DATA 123, 33, 34,123,205, 13, 38, 1,168, 0
13 DATA 253,126, 0,254, 65,202,189,122,221, 9
14 DATA 254, 66,202,189,122,221, 9,254, 67,202
15 DATA 189,122,221, 9,254, 68,202,189,122,221
16 DATA 9,254, 69,202,189,122,221, 9,254, 70
17 DATA 202,189,122,221, 9, 1, 56, 0,253,126
18 DATA 1,254, 78,202,209,122,221, 9,254, 83
19 DATA 202,209,122,221, 9, 1, 7, 0,253,126
20 DATA 2,254, 48,202, 8,123,221, 9,254, 49
21 DATA 202, 8,123,221, 9,254, 50,202, 8,123
22 DATA 221, 9,254, 51,202, 8,123,221, 9,254
23 DATA 52,202, 8,123,221, 9,254, 53,202, 8
24 DATA 123,221, 9,254, 54,202, 8,123,221, 9
25 DATA 221,126, 5, 18, 19,221,126, 6, 18, 33
26 DATA 189,127, 34,142, 64,221,102, 4,221,110
27 DATA 3,195,154, 10, 68, 0, 80, 67, 0, 65
28 DATA 78, 48,178, 9, 96, 9, 65, 78, 49,214
29 DATA 4,190, 4, 65, 78, 50,105, 2, 96, 2
30 DATA 65, 78, 51, 50, 1, 49, 1, 65, 78, 52
31 DATA 151, 0,154, 0, 65, 78, 53, 73, 0, 80
32 DATA 0, 65, 78, 54, 34, 0, 42, 0, 65, 78
33 DATA 55, 15, 0, 24, 0, 65, 83, 48, 38, 9
34 DATA 220, 8, 65, 83, 49,145, 4,124, 4, 65
35 DATA 83, 50, 70, 2, 61, 2, 65, 83, 51, 33
36 DATA 1, 32, 1, 65, 83, 52,142, 0,146, 0
37 DATA 65, 83, 53, 69, 0, 75, 0, 65, 83, 54
38 DATA 32, 0, 40, 0, 65, 83, 55, 14, 0, 23
39 DATA 0, 65, 70, 48, 0, 0, 2, 0, 65, 70
40 DATA 49, 32, 5, 5, 5, 65, 70, 50,142, 2
41 DATA 131, 2, 65, 70, 51, 69, 1, 67, 1, 65
42 DATA 70, 52,160, 0,163, 0, 65, 70, 53, 78
43 DATA 0, 84, 0, 65, 70, 54, 37, 0, 44, 0
44 DATA 65, 70, 55, 16, 0, 25, 0, 66, 78, 48
45 DATA 162, 8, 97, 8, 66, 78, 49, 79, 4, 61
46 DATA 4, 66, 78, 50, 37, 2, 29, 2, 66, 78
47 DATA 51, 16, 1, 15, 1, 66, 78, 52,134, 0
48 DATA 138, 0, 66, 78, 53, 65, 0, 71, 0, 66
49 DATA 78, 54, 30, 0, 38, 0, 66, 78, 55, 13
50 DATA 0, 22, 0, 66, 83, 48, 38, 8,238, 7
51 DATA 66, 83, 49, 17, 4,255, 3, 66, 83, 50
52 DATA 6, 2,254, 1, 66, 83, 51, 1, 1, 1
53 DATA 1, 66, 83, 52,126, 0,131, 0, 66, 83
54 DATA 53, 61, 0, 67, 0, 66, 83, 54, 28, 0
55 DATA 36, 0, 66, 83, 55, 12, 0, 21, 0, 66
56 DATA 70, 48, 38, 9,220, 8, 66, 70, 49,145
57 DATA 4,124, 4, 66, 70, 50, 70, 2, 61, 2
58 DATA 66, 70, 51, 33, 1, 32, 1, 66, 70, 52
59 DATA 142, 0,146, 0, 66, 70, 53, 69, 0, 75
60 DATA 0, 66, 70, 54, 32, 0, 40, 0, 66, 70
61 DATA 55, 14, 0, 23, 0, 67, 78, 48, 38, 8
62 DATA 238, 7, 67, 78, 49, 17, 4,255, 3, 67
63 DATA 78, 50, 6, 2,254, 1, 67, 78, 51, 1
64 DATA 1, 1, 1, 67, 78, 52,126, 0,131, 0
65 DATA 67, 78, 53, 61, 0, 67, 0, 67, 78, 54
66 DATA 28, 0, 36, 0, 67, 78, 55, 12, 0, 21
67 DATA 0, 67, 83, 48,177, 7,125, 7, 67, 83
68 DATA 49,214, 3,196, 3, 67, 83, 50,233, 1
69 DATA 228, 1, 67, 83, 51,242, 0,242, 0, 67
70 DATA 83, 52,119, 0,124, 0, 67, 83, 53, 57
71 DATA 0, 64, 0, 67, 83, 54, 26, 0, 35, 0
72 DATA 67, 83, 55, 30, 0, 38, 0, 67, 70, 48
73 DATA 162, 8, 97, 8, 67, 70, 49, 79, 4, 61
74 DATA 4, 67, 70, 50, 37, 2, 29, 2, 67, 70
75 DATA 51, 16, 1, 15, 1, 67, 70, 52,134, 0
76 DATA 138, 0, 67, 70, 53, 65, 0, 71, 0, 67
77 DATA 70, 54, 30, 0, 38, 0, 67, 70, 55, 13
78 DATA 0, 22, 0, 68, 78, 48, 66, 7, 18, 7
79 DATA 68, 78, 49,159, 3,140, 3, 68, 78, 50
80 DATA 205, 1,201, 1, 68, 78, 51,228, 0,228
81 DATA 0, 68, 78, 52,112, 0,117, 0, 68, 78

```

Program Listing 2 Continues

Line 1120 illustrates the handling of the chords. Because one note is played at a time, chords are entered as arpeggio as when playing a harp. The DN4,1,EN4,1,GS4,1,BN5,13 combination following the sixteenth note at CS5 in line 1120 plays an arpeggio chord with the melody note at B natural of the 5th octave. The sum of the B-values of all notes of a chord must total 16 because it is composed of quarter notes. Therefore, the three notes preceding the melody note BN5 are valued at one each and BN5 is given the remainder, 13, to bring out the melody note clearly. The arpeggio notes of a chord may be given any B-value from .6 to two depending on your taste, but be sure the melody note takes the balance of the total for the chord as a unit note.

The data in line 1180 illustrates two effects. Divisions in timing are handled in CS4,2.67, DN4,2.67, CS4,2.67. The "Carmen March" is written in 2/4 time, meaning two quarter notes per measure or a total of $2 \times 16 = 32$ beats (B-values) per measure. For precise timing, each measure must total 32 in B-value, unless there are ritards or accelerandos. When the music calls for three notes to be played in the same time as one eighth note, as in the above instance, then divide eight (the B-value for an eighth note) by three to get 2.67 as your entry for B after each note.

The second effect in line 1180 comes immediately after BN5,16, the quarter note at BN5. The 1,2 pair tells the program to read only the note NT\$ in line 140 and that the B-value will be constant at two in the succeeding. The 1,2 is followed by AN5,0,0,0, AN5,0 which tells the program to play one sixteenth note staccato at AN5 and follow by a sixteenth (or 2 32nd) rest and then another staccato AN5 sixteenth note.

The passage of reading of NT\$ alone ends with the AN3 note at the end of line 1210. The 6 at the start of line 1215 commences reading NT\$ paired with its B-value again. At the very end of the piece (end of line 1215) there is another arpeggio chord of four A Natural notes covering a three octave span. Because the music calls for a pause at this point, the sum of the B-values for the four notes total 48 rather than the 32 required for normal timing.

The piece ends with the 1, - 1 pair in line 1220. If you wish to end while reading only NT\$ and not the B-value, be sure to end the data with a "6,1, - 1" combination.

Special Effects

Several special effects are not illustrated

“...play a turn when a ~ follows a note.”

in the “Carmen March.” Two quite common ones are grace notes and turns. All grace notes should be given a B-value less than one but greater than .5. The timing should be deducted from the note preceding the grace rather than from the note in front. Thus, if two grace notes of .6 timing each follow a quarter note, then this quarter note should be given a B-value of 14.8 rather than 16.

A turn is required when a ~ sign follows a note in music. Give the note to be turned half its value (an eight for a quarter note for example) and then divide the remaining half evenly among the four notes of the turn. Any other special effect may be accomplished with this program and some ingenuity.

Machine Language Program

The documentation in Program Listing 2 is sufficiently detailed for comprehension of the machine language program. There are two USR entries—one at 7BFE (31742 decimal) to find the note period and the second at 7FD2 (32722 decimal) to generate the tone. The functions of lines 170-770 are to point HL to the first character of the note string in memory and point IX to the start of the note table at 7C8A. IX is incremented until the first three bytes after every fifth from the table start matches the three bytes to which HL points. When the complete match is found, the last two bytes of the five hold the period for the note and this value is transmitted to Basic.

The note table begins with line 810 and ends with line 4170. All the A notes of the entire keyboard are given 120 bytes at the start of the table. This is followed by B notes and so on to G, each given 120 bytes. The naturals, the sharps, and flats succeed each other by occupying 40 bytes of the 120. Octaves zero through seven are covered in the 40 bytes. The program and this table are structured so that any 3-byte string finding its way into the program plays

Note Value	B-Value
Whole	64
Half dot	48
Half	32
Quarter dot	24
Quarter	16
Eighth dot	12
Eighth	8
Sixteenth dot	6
Sixteenth	4
Thirty second	2
Sixty fourth	1

Fig. 3. B-value to Use in Basic

“I BOUGHT IT”
“My biggest loss
of programming
time using
Snappware’s
EXTENDED BASIC
is spent
inserting
my diskette.”

SCOTT ADAMS - PRES. OF ADVENTURE INTL.



Reduce your programming time significantly with Snappware's EXTENDED BASIC. The program is written entirely in machine language for super fast execution and is fully integrated into the TRSDOS* BASIC interpreter, requiring no user memory. Here are just some of the ways EXTENDED BASIC can make your programming task easier:

- Quick way to recover BASIC program following a New, System or Accidental re-boot.
- Single character abbreviations for the most frequently used commands.
- Six single key stroke commands to list the first, last, previous, next or current program line. Even edit current line.
- A powerful cross-reference facility with output to display and/or printer.
- Ability to trace a variable through the code.
- Determine easily if a variable is in use.
- Permits programmer to display and/or print the value of any or all program variables.
- Identifies the variable type for all variables.
- Lists each element of any array separately.
- Program line renumbering facilities allowing for specification of an upper limit of the block of lines to be renumbered, relocation of renumbered blocks of code and duplication of blocks of code.
- Cross reference facility for key words and character strings including global replacement of key works.
- Compresses your program to an absolute minimum by removing extraneous information.
- Merge lines.
- Deletes statements that could not be executed.

If you consider your programming time to be worth money, call us and let us show you how to get more of it.

*TRSDOS™ Tandy Corporation

MODEL II \$200.00
 MODEL III \$125.00

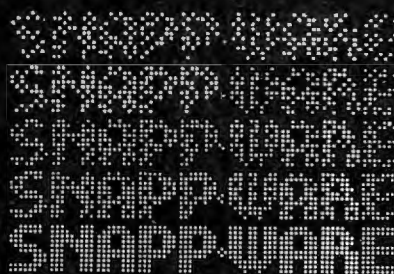

Time saving power
at your fingertips.

CALL TOLL FREE:

1-800-543-4628

OHIO RESIDENTS CALL
 COLLECT: (513) 891-4496

3719 Mantell
 Cinti., Ohio 45236



***** NOTICE *****

PROGRESSIVE ELECTRONICS

is now authorized
SALES and SERVICE
for
MICRO DESIGN PRODUCTS

	M-1 Expansion	M-3 Expansion	Phone Modem
Board & Manual	MDX2 \$74.95	MDX3 \$74.95	MDX4 \$29.95
Parts Kit	\$205.00	\$205.00	\$40.00
Assembled & Tested	\$399.95	\$324.95	\$99.95

Aluminum Enclosures for the MDX2 \$45.00

Mill Internal Drive Installation Kit \$119.95
includes Power Supply, Cables, Mounting Brackets

643 E CHESTNUT ST
LANCASTER OH 43130
614/687-1019 hrs 9-9 EST

IN CHICAGO

... YOU'VE HEARD ABOUT US ...



Emmanuel B. Garcia, Jr. & Associates
203 North Wabash Ave. • Chicago, IL 60601
312/782-9750

- serving the TRS-80⁺ community since 1978
- publisher of "Chicatrug News" (write for sample issue)
- well-stocked display room
- quality products only
- personalized service
- good technical support
- repair facilities

... NOW HEAR THIS ...

ANNOUNCING THE OPENING OF
OUR NEW MORRIS, ILLINOIS STORE:

EbG & Associates
RADIO SHACK[®] DEALER STORE #R-619
531 Bedford Road • Morris, IL 60450
815/942-9521

PREPAID ORDERS SHIPPED PROMPTLY.
AMERICAN EXPRESS / VISA / MASTERCHARGE & C.O.D.
ACCEPTED. (Add \$2 shipping; \$9 per drive or printer.)

*Trademark of Tandy Corporation

✓271

"The naturals, sharps and flats
succeed each other in 40 of the
next 120."

Program Listing 2 Continued

```

82 DATA 53, 54, 0, 61, 0, 68, 78, 54, 25, 0
83 DATA 34, 0, 68, 78, 55, 30, 0, 38, 0, 68
84 DATA 83, 48, 217, 6, 172, 6, 68, 83, 49, 106
85 DATA 3, 87, 3, 68, 83, 50, 179, 1, 175, 1
86 DATA 68, 83, 51, 215, 0, 215, 0, 68, 83, 52
87 DATA 105, 0, 111, 0, 68, 83, 53, 50, 0, 58
88 DATA 0, 68, 83, 54, 23, 0, 32, 0, 68, 83
89 DATA 55, 30, 0, 38, 0, 68, 70, 48, 177, 7
90 DATA 125, 7, 68, 70, 49, 214, 3, 196, 3, 68
91 DATA 70, 50, 233, 1, 228, 1, 68, 70, 51, 242
92 DATA 0, 242, 0, 68, 70, 52, 119, 0, 124, 0
93 DATA 68, 70, 53, 57, 0, 64, 0, 68, 70, 54
94 DATA 26, 0, 35, 0, 68, 70, 55, 30, 0, 38
95 DATA 0, 69, 78, 48, 119, 6, 79, 6, 69, 78
96 DATA 49, 57, 3, 39, 3, 69, 78, 50, 154, 1
97 DATA 150, 1, 69, 78, 51, 203, 0, 203, 0, 69
98 DATA 78, 52, 99, 0, 105, 0, 69, 78, 53, 47
99 DATA 0, 55, 0, 69, 78, 54, 21, 0, 30, 0
100 DATA 69, 78, 55, 30, 0, 38, 0, 69, 83, 48
101 DATA 26, 6, 245, 5, 69, 83, 49, 10, 3, 248
102 DATA 2, 69, 83, 50, 131, 1, 128, 1, 69, 83
103 DATA 51, 191, 0, 191, 0, 69, 83, 52, 93, 0
104 DATA 99, 0, 69, 83, 53, 44, 0, 52, 0, 69
105 DATA 83, 54, 20, 0, 29, 0, 69, 83, 55, 30
106 DATA 0, 38, 0, 69, 70, 48, 217, 6, 172, 6
107 DATA 69, 70, 49, 106, 3, 87, 3, 69, 70, 50
108 DATA 179, 1, 175, 1, 69, 70, 51, 215, 0, 215
109 DATA 0, 69, 70, 52, 105, 0, 111, 0, 69, 70
110 DATA 53, 50, 0, 58, 0, 69, 70, 54, 23, 0
111 DATA 32, 0, 69, 70, 55, 30, 0, 38, 0, 70
112 DATA 78, 48, 26, 6, 245, 5, 70, 78, 49, 10
113 DATA 3, 248, 2, 70, 78, 50, 131, 1, 128, 1
114 DATA 70, 78, 51, 191, 0, 191, 0, 70, 78, 52
115 DATA 93, 0, 99, 0, 70, 78, 53, 44, 0, 52
116 DATA 0, 70, 78, 54, 20, 0, 29, 0, 70, 78
117 DATA 55, 30, 0, 38, 0, 70, 83, 48, 194, 5
118 DATA 160, 5, 70, 83, 49, 223, 2, 208, 2, 70
119 DATA 83, 50, 109, 1, 107, 1, 70, 83, 51, 180
120 DATA 0, 181, 0, 70, 83, 52, 88, 0, 94, 0
121 DATA 70, 83, 53, 42, 0, 49, 0, 70, 83, 54
122 DATA 19, 0, 27, 0, 70, 83, 55, 30, 0, 38
123 DATA 0, 70, 78, 48, 119, 6, 79, 6, 70, 78
124 DATA 49, 57, 3, 39, 3, 70, 78, 50, 154, 1
125 DATA 150, 1, 70, 78, 51, 203, 0, 203, 0, 70
126 DATA 70, 52, 99, 0, 105, 0, 70, 78, 53, 47
127 DATA 0, 55, 0, 70, 78, 54, 21, 0, 30, 0
128 DATA 70, 78, 55, 30, 0, 38, 0, 71, 78, 48
129 DATA 111, 5, 80, 5, 71, 78, 49, 181, 2, 168
130 DATA 2, 71, 78, 50, 88, 1, 86, 1, 71, 78
131 DATA 51, 170, 0, 172, 0, 71, 78, 52, 83, 0
132 DATA 89, 0, 71, 78, 53, 39, 0, 47, 0, 71
133 DATA 78, 54, 17, 0, 26, 0, 71, 78, 55, 30
134 DATA 0, 38, 0, 71, 83, 48, 32, 5, 5, 5
135 DATA 71, 83, 49, 142, 2, 131, 2, 71, 83, 50
136 DATA 69, 1, 67, 1, 71, 83, 51, 160, 0, 163
137 DATA 0, 71, 83, 52, 78, 0, 84, 0, 71, 83
138 DATA 53, 37, 0, 44, 0, 71, 83, 54, 16, 0
139 DATA 25, 0, 71, 83, 55, 30, 0, 38, 0, 71
140 DATA 70, 48, 194, 5, 160, 5, 71, 70, 49, 223
141 DATA 2, 208, 2, 71, 70, 50, 109, 1, 107, 1
142 DATA 71, 70, 51, 180, 0, 181, 0, 71, 70, 52
143 DATA 88, 0, 94, 0, 71, 70, 53, 42, 0, 49
144 DATA 0, 71, 70, 54, 19, 0, 27, 0, 71, 70
145 DATA 55, 30, 0, 39, 0, 205, 127, 10, 229, 33
146 DATA 32, 123, 205, 13, 38, 235, 94, 35, 86, 225
147 DATA 14, 1, 62, 3, 169, 79, 211, 255, 125, 183
148 DATA 229, 194, 219, 127, 44, 69, 16, 254, 203, 124
149 DATA 32, 5, 37, 250, 237, 127, 36, 37, 46, 254
150 DATA 195, 219, 127, 122, 179, 225, 202, 247, 127, 27
151 DATA 195, 206, 127, 33, 104, 122, 34, 142, 64, 195

```

Program Listing 2 Continues

“... you begin to hear washed out bass...”

some note. The default if the first character is not A to G plays a G. If the second character is bad, the flat note is played. Finally, if the third character is not 0-7 it plays the seventh octave by default if a note exists there. If not (notes above CN7) it plays a note of period equal to 30.

The note period, or a calculated rest period, is entered into HL in line 4200. This is temporarily saved while HL goes about the business of getting the Basic D-value into DE in lines 4220-4270. After checking to see if the value in DE indicates a rest (lines 4300-4340) the note is played (lines 4350-4380) by toggling A from two to one and sending the vibration out port FFH. A delay to define the period of vibration is implemented in lines 4400-4430 and continued until HL is decremented to zero. Lines 4440-4480 restore the period to HL and continue the tone until the D-value in DE zeroes. In the rest case, the tone generation lines (4350-4380) are bypassed and no loop back occurs in line 4480 because the D-value of a rest is one. After DE zeroes, the program returns to Basic.

Calculating Periods

The periods in the two bytes following each note in the table of Program Listing 2 are calculated from the vibration frequency of 264 per second for middle C (CN3). Multiply 264 by 1.05946 to obtain the frequency for each half step up from middle C and divide by the same factor for each half step down. This factor doubles the frequency for each full octave step upscale.

The period is calculated from the frequency by the formula $P = 53800/F$. The factor 53800 gives each of the 88 notes a distinct integer for P, all properly related to each other. If you are unsatisfied with the tuning of your computer instrument, modify the periods listed in the table but modify all 88 to preserve the proper relationship. Decrease the factor 53800 for a higher pitch or increase for a lower pitch. If the factor is decreased too much you begin to lose distinction in the 7th octave or perhaps even the 6th. If the factor is increased you begin to hear washed out bass notes in the 0th octave. Remember some periods are listed more than once—GS3, for example, has the same period as AF4.

Using the Music Program

Type in the Basic program through line 340 and Run. Wait for the machine language program to be loaded and for the Ready signal. Next either type in lines

“I BOUGHT IT”

“My biggest loss of programming time using Snappware’s EXTENDED BUILT IN FUNCTIONS is spent inserting my diskette.”

SCOTT ADAMS - PRES. OF ADVENTURE INTL.



Snappware’s EXTENDED BUILT IN FUNCTIONS is a collection of much needed additions to the TRSDOS* BASIC interpreter which greatly extends its convenience and utility. The following features become part of your BASIC language and provide the enhancements without requiring any additional memory. The most important component of EXTENDED BUILT IN FUNCTIONS is an in-memory sort routine, guaranteed to be the fastest general purpose in-memory sort on the market. Along with this you also receive other EXTENDED BUILT IN FUNCTIONS. Here is a sampling:

SRT—Sorts one or more arrays into a specified sequence

FMT—Arranges data into a string variable as with PRINT USING

PDAT/UDATS—Permits user to do arithmetic on dates.

PKS/UPKS—Compresses strings to save disk space.

ETIMS—Shows the difference between two times.

CLEAR—Specifies the number of file blocks to be allocated when you specify high memory and string space.

DELETE—Allows you to dynamically remove portions of a BASIC program.

In addition to these, there are functions unique to Model II and to Model III. The exclusives to Model II are long error messages and PEEK/POKE.

The exclusives to Model III are:

SWAP—Supports exchange of variables with a single statement.

HEXS—Converts numbers to hexadecimal strings.

RESTORE—Allows you to set READ pointer to location of choice.

If you consider your programming time to be worth money, call us and let us show you how to get more of it.

MODEL II	\$100.00
MODEL III	\$ 75.00

*TRSDOS™ Tandy Corporation

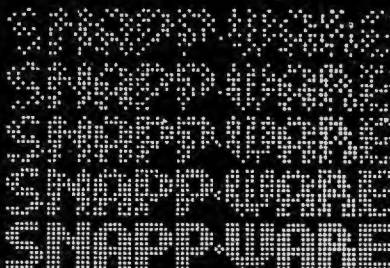

Time saving power at your fingertips.

CALL TOLL FREE:

1-800-543-4628

OHIO RESIDENTS CALL COLLECT: (513) 891-4496

3719 Mantell Cinti., Ohio 45236



SOFTWARE

**FOR YOUR 16K TRS-80
COLOR, MODEL I, III
ATARI 400/800, APPLE II**

**NOW YOUR COMPUTER
CAN ACT LIKE A
COMPUTER SHOULD!!!
WITH OUR
MAGNETIC
MAGAZINES,
YOUR MICRO
WILL ENTERTAIN,
EDUCATE, AND
CHALLENGE YOU.**



On cassette or diskette*, you will receive 6-10 programs every month ranging from games, home entertainment, and personal finance, to more of our unique "teaching" programs.

Our next issue will include:

1. ALIEN INVASION with Graphics
2. Pharaoh's Curse (Adventure)
3. Itemized Deductions (Schedule A)
4. Sine, Cosine, Tangent with Graphics
5. Using Strings
6. Utility of the Month (I)

You've already missed Stock Market Analysis, Concentration, Checkers, Golf, Algebra and Geometry Tests and Football. * Later issues will include Backgammon, Chess, all Tax Schedules, Baseball, and many more. So don't let another issue pass you by! Subscription price for cassette is \$50 per year, \$30 per 1/2 year and \$10 for a trial issue; for diskette \$75 per year, \$45 per 1/2 year and \$15 for a trial issue.

* (Back issues available on request)

THE COLOR ACCOUNTANT

With our complete home accounting system, keeping track of your finances can be as easy as PI.

1. Chart of Accounts Maintenance
2. Complete Checkbook Maintenance
3. Tax Deduction Flags
4. Net Worth Statement
5. Income Less Expense Statement
6. Complete Graph Package (graphs any files)
7. Payments and Appointments Calendar
8. Home Budget Analysis
9. Mailing List
10. Schedule 1040 (Long Form)

All programs are menu-driven and allow add/change/delete. Also, all files and statements can be listed to screen or printer, and saved to cassette or diskette. The cost of THE COLOR ACCOUNTANT is \$75 for cassette and \$80 for diskette. This package requires 16K except for the ATARI 400/800 which requires 24K for cassette and 32K for diskette. THE COLOR ACCOUNTANT also comes with 40 pages of documentation.

the programmer's program



Do you know all the innovative ways of using BASIC commands? The staff at the Programmer's Institute have designed a set of programs explaining everything the manuals omit. The Programmer's Program leads you step by step through the fundamentals of programming your computer. Then you explore the finer points... multiple loops, queues, stacks, game programming, sorts, trees, boolean logic, and memory savers. All these methods make your programming tasks easier and more efficient. Difficult (and very useful) programs are created before your eyes, and designed so you learn at your own speed! The Programmer's Program is a must for every owner of a microcomputer. (\$50 cassette, \$55 diskette).

Order both The Programmer's Program and 1 year's subscription and the total cost is only \$75 cassette, \$100 diskette. If you order now, you will receive a Football Program and Computerized Telephone Directory **ABSOLUTELY FREE** with any \$75 order. So don't wait... order today!

THE PROGRAMMER'S INSTITUTE

A Futurehouse Company
P.O. Box 3191 Dept. B #245
Chapel Hill, N.C. 27514
(919) 489-2198 MC & Visa Welcome



<input type="checkbox"/> Programmer's Program	Year Subscription
<input type="checkbox"/> Color Accountant	1/2 Year Subscription
<input type="checkbox"/> Type of Computer	Trial Issue

ATARI, TRS-80, and APPLE are trademarks of the Atari Family, and Apple Corp. The Programmer's Program, TRC, Appletree, Magazine, and The Color Accountant are trademarks of the Programmer's Institute.

*All software available on cassette for ATARI 400/800, APPLE II+, MODEL I, III, COLOR. On diskette for ATARI 400/800, APPLE II+, MODEL III.

*"... modify the periods listed but
modify all 88 to preserve relationship."*

Program Listing 2 Continued

```

152 DATA 154, 10
153 POKE16562,122:POKE16561,103: CLEAR100:FORZ=31336TO32767:READX
  :S=S+X:POKEZ,X:NEXT
155 IFS=96246THEN300 ELSE PRINT"BAD CHECKSUM IN DATA":STOP
160 DEFINTC-Z:POKE16527,122:POKE16526,104:K=2500:PC=0:D=1:AB=1.4
  9:DK=1230:EK=-8830
170 CLS:G=0:INPUT"TEMPO 1 TO 20 (1 IS FASTEST)":AP:AT=.479*AP:RE
  STORE
180 IF G=0 READ NT$,B ELSE READNT$
185 IF LEN(NT$)=2 ORLEN(NT$)>3 THEN PRINT NT$;" BAD":STOP: 'DELE
  TE THIS LINE AFTER DEBUGGING
190 IFL=VAL(NT$)=1THEN230
195 BC=B-AB
200 P=USR(VARPTR(NT$)):A=K*BC*AT/PC
205 IF A>65535 THEN CLS:PRINT"BC*AT PRODUCT";BC*AT;" TOO LARGE":S
  TOP:'DELETE THIS LINE AFTER DEBUGGING
210 IFA<32768THEND=AELSED=A-65536
215 PRINTNT$;B; 'DELETE THIS LINE AFTER DEBUGGING DATA
220 F=USR(P):GOTO180
230 L=VAL(NT$):IFL<>0THEN270
240 RK=B*AP:IFRK<8THENFORZ=1TO INT(5*AP):NEXT:GOTO180
250 AD=DK*RK+EK:D=0
255 IFAD>65535 THEN PRINT"RK VALUE";RK;" IS TOO LARGE":STOP:'DELE
  TE THIS LINE AFTER DEBUGGING
260 IFAD<32768THENP=AD:F=USR(P):D=1:GOTO180 ELSEP=AD-65536:F=USR
  (P):D=1:GOTO180
270 IFL=LANDB<>0THENG=1:GOTO180ELSEIFL=1THEN170
280 IFL=2THEN350
290 IFL=3THENB=.2*B:GOTO180ELSEIFL=4THENB=.5*B:GOTO180ELSEIFL=5T
  HENB=.8*B:GOTO180ELSEIFL=6THENG=0:GOTO180ELSEIFL=7THENB=1.25*B:G
  OTO180ELSEIFL=8THENB=2*B:GOTO180ELSEIFL=9THENB=5*B
300 CLS:PRINT"MUSIC GENERATOR READY FOR RUNNING":DELETE1-155
310 F=USR(USR(VARPTR(NT$))):FORZ=1TODR:NEXT:RETURN
350 'SPECIAL EFFECTS FOR CHOPIN "BERCEUSE"--TREBLE CLEF--
351 ONBGOTO400,500,600,650,700
400 N=INT(.45*AP):D=13:DR=15:READN1$,N2$
410 FORZ=1TON
420 NT$=N1$:GOSUB310:NT$=N2$:GOSUB310:NEXTZ
430 NT$=N1$:GOSUB310:GOTO180
500 N=INT(.45*AP):D=13:DR=15:READN1$,N2$,N3$
510 FORZ=1TON
520 NT$=N1$:GOSUB310:NT$=N2$:GOSUB310:NEXTZ:N=N/2
530 FORZ=1TON
540 NT$=N3$:GOSUB310:NT$=N2$:GOSUB310
550 NEXTZ:NT$=N2$:D=32:GOSUB310:GOTO400
600 FORZ=1TO138:READNT$:P=USR(VARPTR(NT$)):D=3510/PC:F=USR(P):FO
  RZ1=1TODR:NEXT:NEXTZ
610 FORZ=1TO22:READNT$:P=USR(VARPTR(NT$)):D=3000/PC:F=USR(P):FOR
  Z1=1TODR:NEXT:NEXTZ
620 GOTO180
650 FORZ=1TO9:READNT$:P=USR(VARPTR(NT$)):D=2600/PC:F=USR(P):FORZ
  1=1TODR:NEXT:NEXTZ:GOTO180
700 FORZ=1TO72:READNT$:P=USR(VARPTR(NT$)):D=3510/PC:F=USR(P):FOR
  Z1=1TODR:NEXT:NEXTZ:GOTO180
1000 'DATA FOR CHOPIN "BERCEUSE" TREBLE CLEF
1010 DATAFN4,24,EF4,8,AF5,8,FN4,8,EF4,8,FN4,8,DF4,8,BF4,8,CN4,8,
  EF4,8,AF4,8,DF4,14,1,8,EF4,GF4,BF5
1020 DATAAF5,GF4,FN4,EF4,DF4,EF4,PN4,CN4,BF4,EF4,AF5,PN4,EF4,FN4
  ,DF4,BF4,CN4,EF4,AF4,DF4,BF4,EF4,GF4,BF5,AF5,DF5,BF5,GF4,CN5,AF5
1030 DATAFN4,BF5,GF4,EF4,AF5,PN4,EF4,PN4,DF4,BF4,CN4,EF4,4,AF4,F
  N3,DF4,EF3,DF3,DF4,EF4,CN4,GF4,BF4,BF5,GF4,AF5,FN4,DF5,EF4,BF5,D
  F4,GF4,DN4,CN5,AF4,AF5,AF4,6
1040 DATAAF5,2,AF4,22,AF5,2,AF4,6,AF5,2,AF4,6,FN4,2,AF4,6,EF4,2,
  AF4,6,FN4,2,AF4,6,DF4,2,AF4,6,BF4,2,AF4,6,CN4,2,AF4,6,EF4,2,AF4,
  6,AF5,2,AF4,6,CN4,2,AF4,6,DF4,2,AF4,6
1045 DATADN4,2,AF4,6,EF4,2,AF4,6,EN4,2,AF4,6,PN4,2,AF4,6,BF5,2,A
  F4,6,CN4,2,AF4,6,AF5,2,AF4,6,BF5,2,AF4,6,GF4,1.7,GN4,1.7,AF4,4.6
1050 DATAFN4,1.7,2,1,AF5,BF5,1,2,GN4,AF5,DF5,BF5,FN4,GF4,CN5,AF5
  ,EN4,PN4,BF5,GF4,DN4,EF4,AF5,PN4,CN4,DF4,GF4,EF4,BN4,CN4,PN4,DF4
  ,AN4,BF4,EF4,CN4,GN3,AF4,CN4,BF4,GN3,AF4,BF4,CN4,DF4,EF4,PN4,GF4
1060 DATAGN4,AF5,AN5,CF5,BF5,CN5,BN5,DF5,CN5,DN5,DF5,EF5,DN5,FP5

```

Program Listing 2 Continues

*"If you hear a sour note
press Break . . ."*

350-1220 or merge from your file of music programs. For purposes of merging you might use one of the Merge programs published by Bill Dalesandry or by Dale Rupert in the November 1981 issue of *80 Microcomputing* to good advantage. Keep either one resident in memory where it will not interfere with the resident music generator. Now you can play one piece following another by deleting and merging a new set of music data.

If you type in the "Carmen March," and your typing skill is as aggravating as mine, you will likely have to debug the data of errors. To do this, plug the grey auxiliary lead to your cassette into an auxiliary input of your stereo through an available adapter (from Radio Shack). Switch on your stereo and you are ready to go.

Enter Run and respond to the tempo query with a slow tempo such as 10 and then Enter. If the music plays to the end without a sour note and the tempo query again appears, you have done a perfect job of entering the data. Next, press the Break key and delete lines 155, 185, and 235. Run the program once again but this time at a tempo of 5 which I found best for this piece. After you are satisfied that all is correct, and you wish to save the March in your music files, delete lines 1 through 340 and CSAVE the rest.

If by chance you hear a sour note the first time through, press the Break key as soon as you hear it. The video screen will display the sour note as you entered it along with its B-value. If the note was entered incorrectly edit the correct note in the proper place.

Defects and Changes

The program provides many hours of entertainment, but those purists who insist on flawless musical fare may frown upon some imperfections. Perhaps the most glaring of these is the timing in playing of notes (not rests) of widely differing note value. For example, playing 32 1/32nd notes takes perceptively longer than one whole note simply because the 32 1/32nd notes must traverse the Basic overhead 32 times versus once for the whole note. A power equation in line 180 relating P to the duration of the tone, similar to that in line 180 for rests, will not suffice because the calculation adds to the interval of silence between notes. The best solution is to shorten the Basic program as much as possible.

Shortening the silent interval by reading successive note periods directly from the Basic data and, therefore, eliminating the

"I BOUGHT IT"

"My biggest loss
of programming
time using
Snappware's
AUTOMAP and
AUTOFILE is
spent inserting
my diskette."

SCOTT ADAMS - PRES. OF ADVENTURE INTL.



When working with direct files or creating a formatted screen, Autofile and Automap are indispensable aids.

Autofile is designed to automate for the BASIC programmer the task of moving data elements to and from a direct file. Previously, this was a time consuming chore because the FIELDed variables may not be directly referenced by user logic. The FIELD statement was eliminated, thereby relieving you of the guessing game as to where the FIELDed variable is. In addition, the LSET and the CVx functions are performed automatically. The software, when installed, becomes part of your BASIC interpreter providing the enhancements without additional memory.

Automap is designed to automate for the BASIC programmer the task of presenting information on the video display and accepting information from the keyboard operator. The software consists of two main components: the OFF-LINE COMPONENT used to describe to the system the screen formats and the ON-LINE COMPONENT from within your BASIC program to initialize a screen, send data to the video display and receive data from the keyboard operator. This facility when installed, becomes part of your BASIC interpreter.

Both products complement one another and, if used in conjunction, can save a significant amount of programming time.

If you consider your programming time to be worth money, call us and let us show you how to get more of it.

Automap	MODEL II	\$100.00
	MODEL III	\$ 75.00
Autofile	MODEL II	\$ 75.00
	MODEL III	\$ 60.00

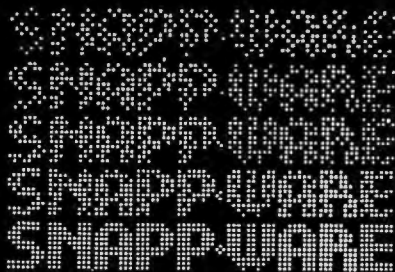

**Time saving power
at your fingertips.**

CALL TOLL FREE:

1-800-543-4628

OHIO RESIDENTS CALL
COLLECT: (513) 891-4496

3719 Mantell
Cinti., Ohio 45236



WHEN IT COMES TO
dBASE II
WE WROTE THE BOOK!

dBASE II USER'S GUIDE \$ 29
SOFTWAREBANC

140 PAGES OF ORIGINAL MATERIAL COVERING NEW dBASE II VERSION. FREE WITH ANYTHING IN THIS AD!

QUICKCODE \$249

FOX & GELLER ASSOCIATES

DESCRIBE YOUR APPLICATION AND LET QUICKCODE WRITE ALL OF THE dBASE PROGRAMS AUTOMATICALLY. NO PROGRAMMING SKILL IS NEEDED.

dUTIL \$ 75

FOX & GELLER ASSOCIATES

POWERFUL UTILITY PACKAGE FOR dBASE PROGRAMMERS. MAKES YOUR PROGRAMS FASTER, SMALLER, AND MORE READABLE.

dBASE II \$595

ASHTON-TATE

THE BEST DATA BASE AVAILABLE HAS BEEN MADE BETTER WITH THESE VALUABLE ADDITIONS. NO RISK 30 DAY MONEY BACK GUARANTEE!

dBASE II CLASSES

SOFTWAREBANC

TAUGHT BY THE AUTHOR OF THE dBASE II USER'S GUIDE. REGISTER FOR BOSTON, HOUSTON, MIAMI, AND NEW YORK NOW.

EXPERT TECHNICAL SUPPORT

OUR SUPPORT LINE IS STAFFED BY EXPERT dBASE II PROGRAMMERS. CAN ANYONE ELSE MATCH THAT?

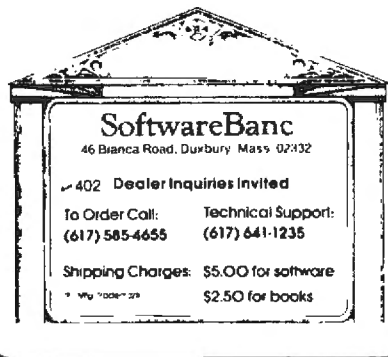

"... The program provides hours of entertainment, but those purists..."

Program Listing 2 Continued

```
,EF5,FN5,EN5,GF5,FN5,GN5,GF5,AF6,GN5,BF6
1070 DATAAF6, FN6, EF6, DF6, FN5, DF6, CN6, BF6, DF5, BF6, AF6, GF5, BF5, GF5
, FN5, EF5, GF4, EF5, DF5, CN5, EF4, CN5, BF5, AF5, 6
1075 DATAAF5, 8, FN5, 12, BF5, 3, EF5, 2, 7, AF5, 2, 7, DF5, 2, 7, GF4, 2, 7, CN5,
2, 7, FN4, 2, 7, BF5, 1, 7, EF4, 1, 7, AF5, 1, 7, DF4, 1, 7, GF4, 1, 7, CN4, 1, 7
1080 DATAFN4, 12, CN4, 4, FN4, 4, BF4, 4, FN4, 3, BF4, 3, FN4, 3, BF4, 3, FN4, 3,
BF4, 3, EF4, 3, BF4, 3, 1, 2, 67, AF4, AN4, BF4, BN4, CN4, DF4, DN4, EF4, EN4, FN4
, FS4, GN4, AF5, AN5, BF5, BN5, CN5, DF5
1090 DATADN5, EP5, EN5, FN5, FS5, GN5, AP6, BF6, AP6, BF6, EF5, BF6, DF5, BF6
, CN5, BF6, BF5, BF6, AF5, DF6, 6, 0, 10, 1, 2, 67, DF6, AF5, 0, GF5, CN6, 0, GF5, E
P4, 0, EF5, BF6, 0
1100 DATABF6, EP4, 0, DF5, AP6, 0, FN5, DF4, 0, AN5, FN5, 0, EP5, CN4, 0, GF4, C
N5, 0, AF5, FN3, 0, DF4, AP5, 0, DF5, AP4, 0, GP4, EP5, 0, GP5, EF4, 0, EP5, BF6, 0
1110 DATABF6, EN4, 0, DF5, AF6, 0, DF6, AF5, 0, GF5, EF6, 0, FN6, CN5, 0, EF5, C
N6, 0, 6, DF5, 2, DF6, 8, 67, 1, 2, 67, CN6, CN6, CF6, BF6, BF6, AN6, AF6, AF6, GN5
, GF5, GF5, FN5, FF5, FF5
1120 DATAEP5, DN5, DN5, DF5, CN5, CN5, CF5, BF5, BF5, AN5, AF5, AF5, GN4, GF4
, GF4, FN4, EP4, EN4, AF4, GF4, FN4, AP4, FN4, EP4, AF4, EF4, FN4, AP4, AF5, GF4
, AP4, GF4, FN4, AF4, GF4
1130 DATAAF4, GF4, GN4, AF4, GN4, AF5, AF4, AF5, AN5, AF4, AN5, AF5, AF4, AF5
, GN4, AF4, AF5, GF4, 6, FN4, 2, 0, 2, AF5, 2, 0, 2, DF5, 2, 0, 2, EP5, 2, 0, 2, FN5, 2
, 0, 2, GF5, 2, 0, 2, FN5, 2, 0, 2, EF5, 2, 0, 2, CN5, 2, 0, 2, BF5, 2, 0, 2, AP5, 2, 67
, BF5, 2, 67, BF5, 2, 67
1140 DATAAF5, 2, 0, 2, AF5, 2, 0, 2, 1, 1, 75, DF5, 0, DF5, 0, GF5, 0, FN5, 0, AF6,
0, DF6, 0, DP6, 0, CN6, 0, BF6, 0, AF6, 0, EF5, 0, FN5, 0, CN5, 0, BF5, 0, AF5, 0, 6,
1, 2, AF4, AF5, CN4, BF4, BF4, AF5, DF4, CN4, CN4, AF5
1145 DATAEP4, DF4, BF4, AF5, DF4, CN4, AP5, DF4, DF4, AF5, FN4, EP4
1150 DATADP4, BF5, FN4, FF4, EP4, CN5, GF4, FN4, FF4, DF5, GN4, GF4, FN4, DN5
, AF5, GN4, GF4, EF5, AN5, AF5, GN4, FF5, BF5, AN5, 6
1160 DATAFN5, 8, 2, 3, BF5, GP5, BF5, AF5, FN5, AF5, BF5, GF5, BF5, FN4, DF5, F
N4, AF5, FN5, AF5, GF4, EP5, GP4, AP5, FN5, AF5, EP4, CN5, EP4, GF4, EP5, GP4, F
N4, DF5, FN4
1170 DATAGF4, EF5, GF4, DF4, BF5, DF4, FN4, DF5, FN4, EP4, CN5, EF4, FN4, DF5
, FN4, CN4, AP5, CN4, EP4, CN5, EF4, DF4, BF5, DF4, EP4, CN5, EF4, BF4, GF4, BF4
, DF4, BF5, DF4, CN4, AP5, CN4
1180 DATAAF4, FN4, AF4, AN4, FS4, AN4, BF4, GN4, BF4, BN4, AF5, BN4, CN4, AN5
, CN4, DF4, BF5, DF4, DN4, BN5, DN4, EP4, CN5, EF4, EN4, CS5, EN4, FN4, DN5, FN4
, FS4, EF5, FS4, GN4, EN5, GN4
1190 DATAAF5, FN5, AF5, AN5, FS5, AN5, BF5, GN5, BF5, BN5, AF6, BN5, CN5, AN6
, CN5, DF5, BF6, DF5, DN5, BN6, DN5, EF5, CN6, EP5, EN5, CS6, EN5, FN5, DN6, FN5
, FS5, EP6, FS5, GN5, EN6, GN5
1200 DATAEP6, FN6, FF6, EF6, DF6, CN6, BF6, AF6, GF5, FN5, FF5, EF5, DF5, CN5
, BF5, AF5, GF4, FN4, FF4, EF4, DF4, CN4, CF4, 2, 2, 2, AN4, BF4, AF4, AF4, BF4, 2
, 4, FN3, AF4, DF4, FN4, BF5, AF5, AF5, AF5, BF6, AF6, 2, 0, 2
1205 DATABF4, 2, 2, 1, AF4, BF4, 2, 4, GN3, AF4, EP4, GF4, BF5, AF5, AF5, AF5, B
F6, AF6, 2, 0, 2
1210 DATA2, 5, DF6, BF6, DF6, AF6, DF6, FN5, DF6, GF5, DF6, FN5, DF6, DF5, DF6
, FN5, CN6, DF5, CF6, FN5, BF6, CN5, AN6, GF5, AF6, CN5, GN5, EP5, GF5, AN5, FN5
, CN5, EF5, AF5, GF5, GF4, CN5, AF5
1220 DATADP5, BF5, DF5, AF5, DF5, FN4, DF5, GF4, DF5, FN4, DF5, DF4, DF5, FN4
, CN5, DF4, CF5, FN4, BF5, CN4, AN5, GF4, AF5, CN4, GN4, EF4, GF4, AN4, FN4, CN4
, EF4, AF4, GF4, GF3, CN4, AF4
1230 DATADP4, 16, DF4, 8, CN4, 4, DF4, 4, EF4, 4, GF4, 4, BF5, 4, BF4, 4, AF4, 16
, AF4, 8, GF3, 4, AF4, 4, CN4, 4, EF4, 4, GF4, 4, GF3, 4, FN3, 4, 0, 4, AF5, 4, GN4, 4
, AF5, 4, BF5, 4, AF5, 4, CN4, 4, GF4, 4, CN5, 4, GF5, 4
1240 DATAFN5, 4, EF5, 4, DF5, 4, FN4, 4, AF5, 4, CN5, 4, BF5, 4, GF4, 4, EF4, 4, B
F4, 4, CN4, 4, EF4, 4, AF4, 24, 1, 2, 67, GN3, AP4, BF4, CN4, DF4, EF4, FN4, GF4, B
F5, 6, AF5, 24, 1, 2, 67, GN4, AF5, CN5, BF5, AF5, GF4, EF4, BF4, CN4
1250 DATABF4, AP4, EF4, DF4, EF4, GF4, FN4, GF4, BF5, AF5, AF6, BF5, AF6, DF5
, AF6, CN5, AP6, FN5, EF5, DF5, DF6, CN6, BF6, AP6, FN5, EF5, DF5, CN5, BF5, AF5
, FN4, EF4, DF4, CN4, BF4, AF4, 6
1260 DATADP4, 24, 1, 4, CF4, DF4, FN4, BF5, AF5, EF4, CF4, FN3, CF4, EF4, AF4
, DF4, CF4, DF4, FN4, BF5, AF5, EF4, CF4, FN3, CF4, EF4, AF4, DF4, CF4, DF4, FN4
, AF5, CF5, DP5
1270 DATAEP5, GF5, FN5, EF5, CF5, AF5, EF4, GF4, FN4, DF4, CF4, AF4, 6, BF4, 2
4, 1, 4, DF4, GF4, AF5, BF5, CF4, BF4, DF4, GF4, AF5, BF5, DP5, GF5, AF6, BF6, GF
5, EF5, DP5
1280 DATAFN5, EF5, BF5, CN5, EF5, DF5, AF5, BF5, DF5, CN5, GF4, AF5, CN5, BF5
, FN4, GF4, BF5, AF5, EF4, FN4, AP5, GF4, DF4, EP4, 6, FN4, 24, 1, 8, EF4, AF5, FN
4, EF4, FN4, DF4, BF4, DF4, AF4
1290 DATABF4, DF4, AF4, GF3, DF4, FN3, 0, 0, 0, FN3, AF4, EF3, EF3, AF4, DF3, 0
```

“... allow space for
‘Carmen’ and the whole
- opera...”

need of the periodfinding portion of the machine language, results in a barely perceptible improvement in melodic quality. Alter the program to read periods directly only if you need the 980 bytes of machine code for extra long music in your Basic program. The rewards in improved sound reaching the ear are not worth the pain of having to look up the period for each note as it is typed into the data.

If you have a 32K or 48K system, you will want to locate the Piano Keyboard and Music Generator in uppermost memory to allow space not only for the “Carmen March” but perhaps for the whole opera. If you do this, be sure to respond to the memory size query, on power up, to the start of the new location minus one. Also POKE the new USR entry for periodfinding (line 170) at the new starting location of Piano Keyboard, and the new USR entry for the Tone Generator (line 310) at 980 memory locations beyond.

One other shortcoming that the musical purist may find objectionable is lack of shading in loud and soft passages. Although the tone frequency is adjustable, I found no way to vary the amplitude in the software. One way that produced a reasonably good crescendo or diminuendo is to use your tape deck if you have one attached to your stereo. Follow the music while recording from the computer and manually adjust the recording level for loudness and softness. After two or three attempts, you could find something that sounds pretty fair on playback.

If you do have an operational cassette tape deck on your stereo, you also may enjoy the opportunity to play more than one voice with music generated by the computer. You can, for example, record the bass of your music and then play back through one side of your stereo. Simultaneously play through the second input of the stereo your computer-generated treble. You will find the note-value and rest relationship timing about perfect for synchronizing the two voices in most cases. A problem may occur if one voice contains many more notes per measure than the other because of the defect in timing cited above. If you take the time to experiment with the treble by changing the timing constant (the 0.2 in line 130 of the Basic program) you will be rewarded with good synchronization and hours of musical enjoyment. ■

Merton Davis, a retired E.I. DuPont chemist, enjoys piano, chess, golf, and computing.

“I BOUGHT IT”

“My biggest loss
of programming
time using
Snappware’s
**COLLEGE EDUCATED
GARBAGE COLLECTOR**
is spent inserting
my diskette.”

SCOTT ADAMS - PRES. OF ADVENTURE INTL.



The Snappware College Educated Garbage Collector (SNAPP-VI) is an intelligent processing function which greatly improves performance of typical BASIC applications. And here's why.

Microsoft uses a 'variable length string' in the BASIC interpreter. Each time the string is assigned a new value, it is relocated in a string pool. Periodically the string pool must be reorganized and condensed into a single contiguous area. Performing this string space reclamation is time consuming and inefficient because this approach evaluates and collects each string individually. The time required is roughly proportional to the square of the number of active strings in the resident program. During reclamation the system seems to 'lock-up' and does not respond to the operator until the process is completed.

This time consuming approach requires a better solution. Snappware has developed a solution which takes advantage of the auxiliary memory available. SNAPP-VI requires only four bytes per active string as a work area. When free storage space is available, our system temporarily borrows, uses and returns the space to the free storage pool when completed. If storage is not available, our system will temporarily transfer out to disk enough of the BASIC program to make room for our work area and return the 'paged out' information to its correct location when completed.

Benchmarked times show, in some situations, SNAPP-VI performs one hundred times as fast as the Microsoft approach.

If you consider your programming time to be worth money, call us and let us show you how to get more of it.

MODEL II \$100.00
MODEL III \$ 75.00

*TRSDOS™ Tandy Corporation

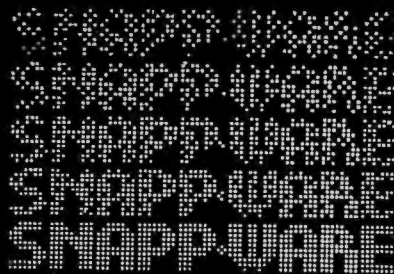

**Time saving power
at your fingertips.**

CALL TOLL FREE:

1-800-543-4628

OHIO RESIDENTS CALL
COLLECT: (513) 891-4496

3719 Mantell
Cinti., Ohio 45236





Making chord-fingering diagrams easy.

Fret No More!

Edward Louis
Box 268
Powell Road
Holland Patent, NY 13354

Have you always wanted to play the guitar like Roy Clark or Chet Atkins, but never had time to really get at it? Or have you spent countless hours practicing, but find yourself bogged down once you get past the C, F and G chords in the "open" position?

For twenty years I tried to play that instrument, but with limited success. I never liked tediously deciphering and memorizing one chord at a time. I was even more frustrated when I witnessed professional performers effortlessly moving their fingers to produce the most beautiful music.

After becoming fairly proficient with my TRS-80, I decided there must be a way to take some of the tedium out of learning to play the guitar. The program I will describe is the result of over a year of continuous refinement on my initial effort.

Because of the program, learning a new song is now a matter of one session rather than weeks of practice. Although not my original intent, I have found the use of this program as an educational tool even more effective than its application as a chord finder.

Face the Music

There are many chord forms. This multiplicity helps explain why it is not easy to learn to play the guitar.

The Key Box

Basic Level II
Model I
16K RAM

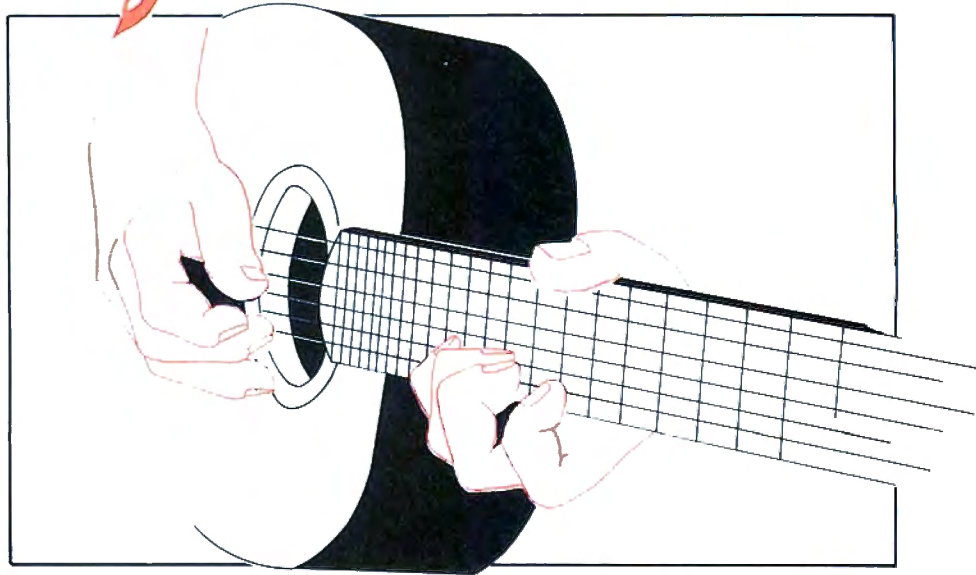

There are some compensating factors when comparing the guitar to other instruments. The guitar is one of the few instruments that allows you to play in any key signature by merely moving your hand up or down a few frets, providing the original chord did not contain any "open" notes (notes which required no fret fingered on a string).

(This is analogous to a machine language program that is completely relocatable, providing all jumps are relative and do not exceed the top memory address.)

I implemented these factors as a set of routines which convert conventional chord name and melody note inputs to finger positions on a schematic representation of the guitar keyboard.

The program has the following capabilities: You can enter up to 40 chords in any sequence.

Entry is in the standard format found on most published sheet music. A null input (entry without first entering an alphanumeric) is used for any element you need not specify. For example, you would enter a B-flat minor seventh (B bm 7) chord as follows:

```
B <Enter>
B <Enter>
M <Enter>
7 <Enter>
```

You would enter a C chord as:

```
C <Enter>
<Enter>
<Enter>
<Enter>
```

There will always be four <Enters> per chord, but as few as one or as many as four specifiers.

You enter the melody notes as shown in this example. You would enter A-sharp (A#) as:

```
A <Enter>
# <Enter>
```

You would enter G as:

```
G <Enter>
<Enter>
```

Thus there are always two <Enters> for each melody note but as few as one specifier. Program prompts should make this clear. When 40 chords have been processed or when you enter x, the program reverts to the menu.

After you have entered one or more

Call or Write Your Nearest Snappware Distributor

MICRO-80
284 Goodwood Road
Clarence Park
Adelaide South Australia
Ph-(08) 2117224

DIGI-TEK SYSTEMS
65 Thornridge Circle
Kitchener Ontario N2M-4V9
Ph-(519) 742-8205

STRAWFLOWER ELECTRONICS
50 North Cabrillo
Half Moon Bay
California 94019
Ph-(415) 726-9128

COMPUTER MAGIC
115 Wiltshire Avenue
Louisville, Kentucky 40207
Ph-(502) 893-9334

E-C DATA
Tornevangsvej 88
P.O.B. 116
DK-3460
Birkerød, Denmark
Ph +45/2/81/ 81 91

SYSTEM SOFT
49, Dunvegan Drive
Rise Park
Nottingham, England
NG5 5Dx
Ph-(0602) 275559

CUSTOM COMPUTING
104 Bushwick Rd.
Poughkeepsie, NY 12603
Ph-(914)-471-9318

AEROCOMP
Redbird Airport
Hanger 8
Dallas, Texas 75232
Ph-(214) 339-5104

NOTICE

Snappware Goes On Trial! You Be The Judge!

Snappware knows your programming time is valuable. That's why we are offering a trial package that will cut your programming time up to 75%!

This unprecedented offer allows you to judge for yourself the value of our software using *your* hardware at *your* convenience. Our five best selling products: EXTENDED BASIC, EXTENDED BUILT IN FUNCTIONS, COLLEGE EDUCATED GARBAGE COLLECTOR, AUTOMAP and AUTOFILER, are all available to you on a trial basis for only \$50.00 for the Model II and \$35.00 for the Model III. We're convinced that after you see how well our software helps you perform programming tasks, you will purchase them like thousands of others have.

Our trial package consists of a master diskette which may be used to create one working copy. Your purchase price for the trial package will be credited toward the purchase of any software Snappware sells.

If for any reason you are not satisfied, just return the trial diskette and working copy and we will refund your money, no questions asked. With an unconditional guarantee like this, you can't lose.

Call our toll free number 800-543-4628 to put us on trial. We're sure your verdict will be: Snappware saves you time and money.

MODEL II Trial Package \$50.00
MODEL III Trial Package \$35.00



**Time saving power
at your fingertips.**

CALL TOLL FREE:

1-800-543-4628

**OHIO RESIDENTS CALL
COLLECT: (513) 891-4496**

**3719 Mantell
Cinti., Ohio 45236**



"Have you always wanted to play the guitar like Roy Clark or Chet Atkins, but never had time to really get at it?"

chords, there are a number of program options. You can display the chords on the screen with a variable time delay between chords. You can produce a printout of any chord if you press H while it is displayed.

You can repeat the chord display sequence by entering a new time delay number followed by ,1.

The display sequence will end if after a sequence is completed you enter any number followed by ,0.

You can store a sequence of chords and its associated song name on cassette. (You can substitute disk storage as a sequential file, but you must change program constants for the machine language portion to make room for your DOS Basic.)

To use the program, save memory at 29778. CLOAD the program. Use menu item one to create as many chords and associated melody notes as you desire (up to 40 chords).

Menu item one will ask you for a key and a song name. Answer the key question with C if you do not want to transpose (even if the song you are entering is in some other key). Input the other key names (C# to B) to

offset your chord entries by an appropriate amount. For example, if you enter a song written in C with a key of F, the chords will show up on the fret matrix display as if the song were in F. If you enter a song written in Eb with a key of F, the fret matrix will display the song in Ab. This may sound complex if you know little music theory. You can always use C as a key name and not worry about it, but if you like automatic transposition, the feature is helpful.

When you have entered one or more chords and melody notes, you may go back to the menu by entering x instead of a chord name. At this point you may display or save your chord sequence. If you choose to display, please pay attention to the prompts. It takes a little time to POKE the chord elements into memory.

When the fret matrix appears, be sure to enter only those numbers asked for. If you enter strings or commands at this time, the fret matrix will be broken up and you will have to go back to the menu.

The first time the fret matrix appears, enter a number from 1-256 (not zero unless you want a very long delay). This is a time

value (an entry of 10 equals about three seconds). This is the length of time each chord is displayed.

As soon as you have done this, the chords will appear one by one on the fret matrix background, until all have been displayed. At that time you may enter another number (again for display length) followed by ,1. If you enter ,0 the program will return to the menu.

During each chord display, you can get a printout of that particular chord by pressing H. You must have a printer ready and, if you have a serial RS-232 interface, its driver must be in place.

A typical display appears in Fig. 1. The asterisks across the top of the diagram represent the six strings and those down the sides represent the frets with numbering on every other fret to avoid clutter. In this diagram, one F tells you to hold down

Program Listing 1

```

10 CLS: PRINTCHR$(23):PRINT @ 200,"G-U-I-T-A-R":FOR B=1 TO 200:NEXT B:CLEAR
 500
20 ZAH = 29779
30 FOR ZII = 29779 TO 30062
40 READ ZI%: POKE ZAH,ZI%: IF ZAH=32767 THEN ZAH=-32768 ELSE ZAH=ZAH+1
50 NEXT ZII: GOTO 250
60 DATA 205,127,10,34,111,117,33,14,10,34,113,117,237,98,34
70 DATA 115,117,34,117,117,237,91,113,117,33,175,117,25,17,21
80 DATA 61,1,66,0,237,160,226,175,116,217,62,5,33,117,117,190
90 DATA 40,5,17,4,0,24,14,42,117,117,1,6,0,237,66,34,117,117
100 DATA 17,44,0,42,115,117,25,34,115,117,17,21,61,25,34,121
110 DATA 117,33,117,117,52,217,237,91,121,117,24,198,58,111
120 DATA 117,71,17,255,255,33,222,57,25,56,253,205,39,117,16
130 DATA 242,33,21,61,54,32,34,119,117,237,91,119,117,19,1,20
140 DATA 0,237,176,1,45,0,9,34,119,117,237,75,119,117,17,249
150 DATA 63,237,82,250,232,116,24,5,237,98,9,24,215,42,113,117
160 DATA 17,66,0,237,82,34,113,117,40,9,33,112,117,53,40,3,195
170 DATA 95,116,201,33,125,117,54,32,34,119,117,237,91,119,117
180 DATA 19,1,130,10,237,176,201,0,0,0,0,0,0,32,0,32,0,32
190 DATA 0,0,0,42,38,64,34,92,117,34,100,117,58,2,56,254,1
200 DATA 192,245,197,213,229,33,120,60,22,13,6,64,78,62,95,145
210 DATA 56,9,121,14,32,145,56,7,78,24,11,14,42,24,7,126,254
220 DATA 13,40,10,24,245,205,0,0,35,16,224,14,13,205,0,0,21
230 DATA 194,63,117,225,209,193,241,201
250 DIM M(40):DIM F(40):DIMS(40):DIM NC(40):DIM N1S(40):DIM N2S(40):DIM N4S
(40):DIM N5S(40):DIM N(40):DIM T(40)
260 DIM KES(12):DIM NES(12):DIM GT(6,13)
270 DATA A,2,B,4,C,5,D,7,E,9,F,10,G,12
280 FOR OT=0 TO 6
290 FOR UM=0 TO 1
300 READ WNS(OT,UM)
310 NEXT UM,OT
320 DATA F,GB,G,AB,A,BB,B,C,DB,D,EB,E
330 DATA 1,2,3,4,5,6,7,8,9,10,11,12
340 DATA 5,10,3,8,12,5
350 DATA 6,11,4,9,1,6
360 DATA 7,12,5,10,2,7
370 DATA 8,1,6,11,3,8

```

Program Listing 1 continues

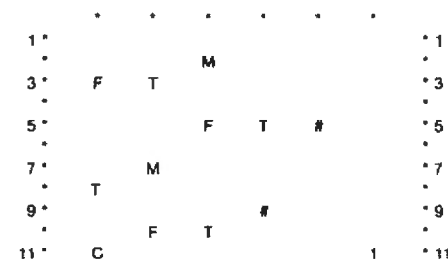

Figure 1

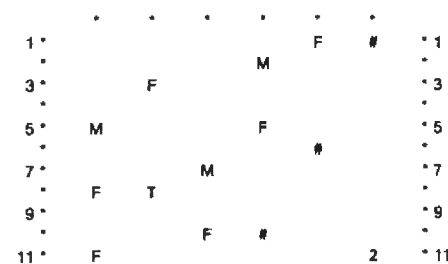

Figure 2

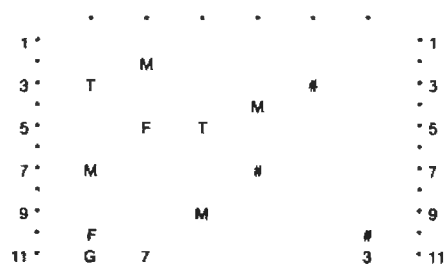

Figure 3

GRAPHICS

THE NEW DIMENSION IN WORD PROCESSING FROM **SIMUTEK**

Word processing will never be the same.

CopyArt™ from Simutek is the first word/graphics processor for TRS-80 Mod. I & III, or PMC-80 and 81. CopyArt gives you unmatched editing flexibility. Change sizes and styles of type in a single line. Insert or delete characters, words and lines. Underline, bold face and make block moves simply. Pagination, headers and footers are a snap. You have complete format control, including justification, centering and flush right copy positioning.

And that's just the beginning.

CopyArt™ is also a graphics generator that can make words and letters in any size, produce graphs, charts, cartoons, logos, borders and illustrations. Business graphs and charts can be intermixed with text to produce reports of exceptional quality. CopyArt's scrolling capability frees you from the bonds of a 64 column screen. CopyArt can simulate a page up to 255 characters wide.

Commands in CopyArt are as simple as 'I' for Insert, 'B' for block move, etc. CopyArt even supports DOS commands like DiRectory, FREE and KILL. A special HELP command gives you instant access to an on-line manual.

CopyArt™ makes word processing more flexible than ever before. It supports the full graphics character sets of Epson and Okidata printers as well as the proportionally spaced justification superscripting, and subscripting capabilities of Centronics' 737 and 739 printer and Radio Shack's Line Printer IV. On non-graphic printers (C-Itoh, Diablo, Radio Shack Daisy Wheel, and others with the ability to turn off linefeeds) CopyArt creates pseudographics by overstriking standard characters. On every printer, especially dot matrix printers, the double printing feature produces unbelievably crisp copies.

(Headline and illustrations produced on CopyArt)

Technical questions? Call (602) 323-9391. Dealer inquiries welcome.

TRS-80 is a TM of Radio Shack, a Tandy Corporation • CopyArt is a TM of Simutek Computer Products Inc. ↗12

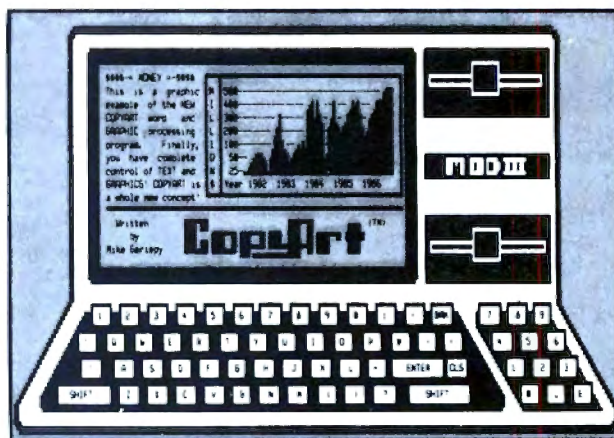

CopyArt™ WORD/GRAPHICS PROCESSOR FROM SIMUTEK

Diskette and instruction manual ___ \$149.95

Requires TRS-80 MOD I or III, 48K, 1 disk

10 DAY MONEY BACK GUARANTEE

To order call **TOLL FREE 800-528-1149** for VISA
MasterCard American Express COD orders only.

Or mail check or money order to

SIMUTEK

Computer Products Inc.

4877 E. Speedway, Tucson, AZ 85712

"The guitar is one of the few instruments that allows you to play in any key signature by moving your hand up or down a few frets."

the first string at the third fret.

Just place your fingers on one of each of the different alphas in a given cluster, and the proper chord will result. On each display there will be two or three clusters with a melody note (signified by #). You can play the chord and melody note in more than one position on the guitar: choose the most convenient and best-sounding.

For those of you with some musical background, the alphanumeric indicators indicate these parts of the chord:

= melody note
T = root
M = third
F = fifth
S = seventh or ninth

This information is not necessary to use the program. If this display confuses you, you can change the program at lines 2820-3050 (see Program Listing 1) so all POKE alphas are the decimal equivalent of whatever you desire. For example, if you want all xs, replace the various ASCII decimals with 88.

At the bottom of each chord display, fret eleven, is the chord number in the sequence and the name of the chord.

I suggest that to get started you use a two or three chord sequence until you become familiar with the system. For example, a common sequence used in Latin songs consists of C, F and G7 repeated over and over. Enter these just once followed by an X. Use melody notes E, F and D respectively. The results should be as shown in Figs. 1-3.

Program Description

Lines 20-230 POKE the machine language portion (thanks to Ron Cain in the May 1981 issue of *80 Microcomputing* for making this an easy task with his Encoder program).

The menu resides in lines 570-640.

Look at the ON GOTO statements, and you will see that each segment is in the lines as shown:

Create	line 950
Cassette Save	line 3470
Display	line 3070
Instructions	line 850
Cassette load	line 3390

Create (line 950) is a conversion routine which changes the chord name input to array elements representing each chord and melody note. These arrays are saved to or loaded from the cassette (or disk if you make that conversion). These arrays are also a basis for the display.

Program Listing 1 continued

```

380 DATA 9,2,7,12,4,9
390 DATA 10,3,8,1,5,10
400 DATA 11,4,9,2,6,11
410 DATA 12,5,10,3,7,12
420 DATA 1,6,11,4,8,1
430 DATA 2,7,12,5,9,2
440 DATA 3,8,1,6,10,3
450 DATA 4,9,2,7,11,4
460 DATA 5,10,3,8,12,5
470 FOR X=1 TO 12
480 READ NE$(X)
490 NEXT X
500 FOR Q=1 TO 12
510 READ NE$(Q)
520 NEXT Q
530 FOR R=1 TO 13
540 FORC=1 TO 6
550 READ GT(C,R)
560 NEXT C,R
570 PRINT @ 530,"BY EDWARD LOUIS":FOR B=1 TO 1000:NEXT B
580 CLS:PRINT @ 74,"***MENU***":PRINT:PRINT
590 CLS:PRINT "TO ENTER NEW SONG TYPE 1"
600 PRINT "TO SAVE SONG ON CASSETTE TYPE 2"
610 PRINT "TO DISPLAY SONG TYPE 3"
620 PRINT "TO LOAD SONG FROM CASSETTE TYPE 5"
630 PRINT "TO DISPLAY INSTRUCTIONS TYPE 4"
640 INPUT Q: ON Q GOTO 950,3470,3070,650,3390
650 CLS:PRINT "THIS PROGRAM ALLOWS THE STORAGE, DISPLAY,"
660 PRINT "AND/OR HARD COPY OF GUITAR CHORDS PLUS AN ASSO-"
670 PRINT "CIATED MELODY NOTE FOR UP TO 40 CHORDS IN A SEQU-"
680 PRINT"ENCE. THE DISPLAY AND HARD COPY PROVIDE UP TO"
690 PRINT"THREE SETS OF FINGERING FOR EACH CHORD AND MELODY"
700 PRINT"NOTE. THIS PROVIDES FLEXIBILITY AND AN EASY LEARNING"
710 PRINT"MEMORIZATION TECHNIQUE THAT EVENTUALLY LEADS TO"
720 PRINT"A GOOD FAMILIARITY WITH THE GUITAR KEYBOARD"
730 PRINT"CHORDS ARE ENTERED WITH STANDARD NOTATION"
740 PRINT"AS SEEN ON MOST SHEET MUSIC. THE CHORD SHOULD BE"
750 PRINT"ENTERED FOLLOWED BY AN ASSOCIATED MELODY NOTE."
760 PRINT"THIS SEQUENCE IS REPEATED FOR EACH COMBINATION"
770 PRINT"OF CHORD AND MELODY NOTE. IF DESIRED, A NULL INPUT"
780 PRINT"WILL BE ALLOWED FOR ANY INDIVIDUAL CHORD OR MELODY NOTE. "
790 PRINT:INPUT "***TO SEE MORE INSTRUCTIONS,PRESS <ENTER>***":X
800 CLS:PRINT "AN EXAMPLE OF CHORD NOTATION IS 'CM7' WHICH "
810 PRINT"IS READ AS C MINOR SEVENTH. THIS EXAMPLE WOULD BE"
820 PRINT"ENTERED AS C,NULL,M,7. IF A SEQUENCE OF LESS"
830 PRINT"THAN 40 CHORDS IS DESIRED, AN <X> WILL END THE"
840 PRINT"SEQUENCE."
850 PRINT"CHORDS WILL BE DISPLAYED SEQUENTIALLY AT"
860 PRINT"THE RATE SELECTED AND WILL REPEAT AS A COMPLETE"
870 PRINT"SEQUENCE ON REQUEST. RAM CONTENTS ARE DESTROYED ON"
880 PRINT"RESTARTING THE PROGRAM SEQUENCE BUT IF THE SONG IS"
890 PRINT"SAVED ON DISK OR CASSETTE IT CAN BE RELOADED. "
900 PRINT"HARD COPY CAN BE OBTAINED FOR EACH CHORD"
910 PRINT"BY PRESSING <H> DURING THE TIME DELAY AFTER EACH"
920 PRINT"CHORD IS DISPLAYED ."
930 PRINT:INPUT"END OF INSTRUCTIONS,***TO RETURN TO MENU PRESS <ENTER>***":
X
940 GOTO 580
950 CLS:PRINT "LOADING CHORD DATA"
960 INPUT"KEY":K$
970 INPUT"NAME OF SONG":Y$
980 POKE 16526,4:POKE 16527,117
990 X=USR(N)
1000 U$="":N1$=""
1010 Z1=2640
1020 INPUT"1ST ELEMENT OF CHORD 'EXAMPLE C,B,A,D,G'":N1$
1030 IF N1$="X" THEN 1040 ELSE 1050
1040 NL=NC:GOTO 580
1050 GOSUB 3270
1060 N2$="":U$=""
1070 CLS:INPUT"2ND ELEMENT OF CHORD,'# FOR SHARP,B FOR FLAT,NULL FOR NATURA
L'":N2$
1080 IF N2$="#" THEN 1110
1090 IF N2$="B" THEN 1120
1100 GOTO 1130
1110 N2=1:GOTO 1140
1120 N2=-1:GOTO 1140
1130 N2=0:GOTO 1140
1140 N3=N1+N2
1150 IF N3=13 THEN N3=1
1160 U$=STR$(N3)
1170 V$="":N4$=""

```

Program Listing 1 continues

MORE BYTE PER BUCK

**OUR LOW PRICES INCLUDE FREE SHIPPING
SATISFACTION GUARANTEED BY SIMUTEK**

COMPUTERS

Complete MODEL III COMPUTER

Model III with 48K memory, 2 disk drives, 370K storage, and ready to run with TRSDOS 1.3 and manual. 120 day Simutek warranty parts and labor. Compatible with all Radio Shack software. \$1899.99

Model III with 48K, 2 double sided 40 track disk drives with 750K storage. Comes with NEWDOS 80 V.2 and manual. 120 day Simutek warranty parts and labor. Compatible with Radio Shack software. Complete and ready to run. \$2389.99

MODEL III FIVE MEGABYTE HARD DISK

Comes with modified DOSPLUS. No installation required, just plug in 50 pin bus. Complete and ready to run. \$2499.99

MODEL III INTERNAL DISK DRIVE KITS

If you can use a phillips screwdriver, you can easily install Simutek's Model III disk drives and controller in less than an hour. Absolutely NO SOLDERING, TRACE CUTTING OR TECHNICAL KNOWLEDGE REQUIRED! The J & M controller is the best on the market today. We've tried others and found J & M's the finest and easiest to install. We warranty the J & M controller for 120 days against defects in workmanship.

ONE 40 TRACK TANDON DISK DRIVE WITH 185K STORAGE, and J & M controller. Radio Shack DOS, manual. No soldering or trace cutting required. Ready to install with instructions. \$619.99

TWO 40 TRACK TANDON DISK DRIVES 370K STORAGE, with J & M controller Radio Shack DOS, manual. No soldering or trace cutting. Ready to install and run. Instructions. \$889.99

TWO DOUBLE SIDED 40 TRACK DISK DRIVES with 750K storage and J & M controller. NEWDOS 80 V.2. and manual and Model III DOS. No soldering or trace cutting. Ready to install and run. Full instructions. \$1299.99

DISK DRIVES

MODEL I DISK DRIVES

ONE TEC DISK DRIVE 40 TRACK DISK DRIVE with 5ms track to track access time, with power supply chassis, extender cable and shipping for TRS-80. One year warranty on parts and labor. Ten day money back guarantee. Model I or III \$279.00

ONE TEAC 40 TRACK DISK DRIVE, 30 ms track to track, with P/S and chassis, ready to run as drive 0-4. 10 day money guarantee. One year warranty \$279.00

ONE TANDON 40 TRACK DISK DRIVE, 5 ms track to track, with P/S and chassis, ready to run as drive 0-4 or Model III external. 10 day money back warranty \$279.00

ONE 2 DRIVE cable for Model I or III. (Specify) \$25.00

ONE 4 DRIVE cable for Model I only \$35.00

PRINTERS

Letter quality Daisywheel
TEC C-Itch 40 CPS Parallel \$1599.99
TEC C-Itch 40 CPS Serial \$1649.99
TEC C-Itch 45 CPS Parallel \$1799.99
TEC C-Itch 45 CPS Serial \$1899.99
TEC C-Itch tractor feed \$269.00

High quality dot matrix
TEC C-Itch PROWRITER 8510 \$539.99
Epson MX-80 \$479.99
Epson MX-80 F/T \$599.99

Epson MX-100 \$799.99
Epson Graphtrax \$89.99
Malibu 200 dual mode \$2695.99
Okidata microline 80 \$369.99
Okidata microline 82A \$599.99
(Free tractor feed)
Okidata microline 83A \$799.99
(Free tractor feed)
Okidata microline 84 \$1269.99
(Free tractor feed)

Printer Cable for Expansion Interface or Model III computer \$29.95



ACCESSORIES/ SOFTWARE, ETC.

16K MEMORY SET SPECIAL

\$17.89 with Instructions for MOD I, III Color 4K, Apple, Exidy, one year warranty 200 NS \$17.89

MODEL I, III SOFTWARE

LDOS \$149.95
NEWDOS 80 Ver. 2.0 \$139.00

DOSPLUS...NEW VERSION! \$139.95

DISK HOLDER 5-1/4 \$21.95

PERCOM'S DOUBLER II and DoubleDOS. The best and easiest to install. Double density mod for Model I. \$159.95

BOOKS

MICROSOFT BASIC DECODED AND OTHER MYSTERIES..... \$29.95
TRS-80 DISK AND OTHER MYSTERIES..... \$22.50
BASIC FASTER AND BETTER..... \$29.95
CUSTOM TRS-80..... \$29.95



\$21.95



SUPER MODEM

ESI Lynx smart modem for MOD I or III. Does not require RS-232. Auto answer/dial. Complete with terminal AND host programs. \$279.95

Stop those headaches and eye strain! ZENITH GREEN SCREEN MONITOR and TRS-80 CABLE \$149.00

SIMUTEK HAS BEEN SATISFYING CUSTOMERS NATIONWIDE FOR THREE YEARS

IF NOT FULLY SATISFIED WITH ANY HARDWARE FOR ANY REASON, RETURN WITHIN TEN DAYS FOR A FULL REFUND OR EXCHANGE. Sorry, no refunds on software.

QUESTIONS? WE KNOW TRS-80S CALL OUR TECHNICAL HOTLINE FOR QUICK AND PROFESSIONAL ANSWERS. (602) 323-9391

ORDERS RECEIVED TODAY ARE SHIPPED TOMORROW. IF AN ITEM IS TEMPORARILY OUT OF STOCK YOU ARE NOT CHARGED UNTIL IT IS SHIPPED.

USE OUR DIME TO ORDER TOLL FREE. (ORDERS ONLY)

(800) 528-1149

FREE SHIPPING ON ALL ORDERS!!
C.O.D.'S OVER \$200 REQUIRE 10% DEPOSIT. ALL C.O.D.'S WILL REQUIRE CASH OR CERTIFIED CHECK FOR PAYMENT.
WE ACCEPT AMERICAN EXPRESS, VISA and MASTERCARD. NO SURCHARGE FOR CREDIT CARD ORDERS!
SORRY, PERSONAL CHECKS REQUIRE 4-5 WEEKS TO CLEAR.



SIMUTEK COMPUTER PRODUCTS INC.

4897 E. SPEEDWAY, TUCSON, ARIZONA 85712 (602) 323-9391 (800) 528-1149

TRS-80 IS A TM OF RADIO SHACK, A TANDY CORP.

CANADIANS

NOW IN STOCK

ACORN SOFTWARE

BIG FIVE

INSTANT SOFTWARE

CREATIVE COMPUTING

ADVENTURE

INTERNATIONAL

APPARAT INC.

EPSON PRINTERS

MANY MORE

MOD I • MOD III • COLOR

Excellent 5¼" Diskettes
S. Den. or D. Den.
Fully Guaranteed

Lower Case Mod - Mod I
One IC \$29.95

IBM Selectric Printer
Conversion Kit \$825.00

VISA

Phone or Write for Info.
(403) 423-3919

CMD MICRO 181
10546 - 106 Street
Edmonton, Alberta
T5H 2X6

Program Listing 1 continued

```
1180 CLS:INPUT"3RD ELEMENT OF CHORD,NULL FOR NORMAL,M FOR MINOR,O FOR DIMIN
ISHED,+ FOR AUGMENTED";N4$
1190 IF N4$="+" THEN 1230

1200 IF N4$="O" THEN 1230
1210 IF N4$="M" THEN 1240
1220 IF N4$="" THEN 1250
1230 V$=N4$:GOTO 1260
1240 V$="3":GOTO 1260
1250 V$="0":N5$=""
1260 CLS:INPUT"4TH CHORD ELEMENT,NULL FOR NONE,7 FOR SEVENTH,D FOR MAJOR SE
VENTH,9 FOR NINTH";N5$
1270 IF N5$="9" THEN 1310
1280 IF N5$="7" THEN 1310
1290 IF N5$="D" THEN 1310
1300 IF N5$="" THEN 1320
1310 W$=N5$:GOTO 1330
1320 W$="0"
1330 CLS:INPUT"FIRST ELEMENT OF MELODY NOTE, 'EX.=A,B,C,D,ETC.'";N6$
1340 GOSUB 3320
1350 N7$=""
1360 CLS:INPUT"2ND ELEMENT OF MELODY NOTE,# FOR SHARP,B FOR FLAT,NULL FOR N
ATURAL";N7$
1370 IF N7$="#" THEN 1400
1380 IF N7$="B" THEN 1410
1390 IF N7$="" THEN 1420
1400 N7=1:GOTO 1430
1410 N7=-1:GOTO 1430
1420 N7=0:GOTO 1430
1430 N8=N7+N6
1440 IF N8=13 THEN N8=1
1450 N9=STR$(N8)
1460 CLS
1470 FOR X=1 TO 12
1480 IF KE$(X)=K$ THEN 2640
1490 NEXT X
1500 FOR Q=1 TO 12
1510 IF VAL(N9)=VAL(N6$(Q)) THEN 2670
1520 NEXT Q
1530 IF VAL(U9)=0 THEN 3130
1540 FOR Q=1 TO 12
1550 IF VAL(N6$(Q))=VAL(U9) THEN 2690
1560 NEXT Q
1570 IF T>12 THEN T=T-12
1580 IF VAL(V9)=3 THEN M=3+T
1590 IF VAL(V9)=3 THEN F=7+T
1600 IF V9="#" THEN M=4+T
1610 IF V9="#" THEN F=8+T
1620 IF V9="#" THEN M=6+T
1630 IF V9="O" THEN M=3+T
1640 IF V9="O" THEN F=6+T
1650 IF V9="O" THEN M=6+T
1660 IF VAL(V9)=0 THEN M=4+T
1670 IF VAL(V9)=0 THEN F=7+T
1680 IF VAL(W9)=7 THEN S=10+T
1690 IF W9="D" THEN S=11+T
1700 IF VAL(W9)=9 THEN S=10+T
1710 IF W9="D" THEN S=1700
1720 IF VAL(W9)=0 THEN S=0
1730 IF M>12 THEN M=M-12
1740 IF F>12 THEN F=F-12
1750 IF S>12 THEN S=S-12
1760 IF N>12 THEN N=N-12
1770 NC=41-Z1/66
1780 Z1=Z1-66:IF Z1=0 THEN 500
1790 T(NC)=T:M(NC)=M:F(NC)=F:S(NC)=S:N(NC)=N:NC(NC)=NC:N1$(NC)=N1$:N2$(NC)=
N2$:N4$(NC)=N4$:N5$(NC)=N5$
1800 PRINT "YOU HAVE INPUT ";NC;"CHORDS"
1810 PRINT "NEXT CHORD OR 'X' TO END SEQUENCE":GOTO 1820
1820 CLS
1830 PRINT @ 301,"1":PRINT @ 271,"1"
1840 PRINT @ 429,"3":PRINT @ 399,"3"
1850 PRINT @ 557,"5":PRINT @ 527,"5"
1860 PRINT @ 685,"7":PRINT @ 655,"7"
1870 PRINT @ 813,"9":PRINT @ 783,"9"
1880 PRINT @ 941,"11":PRINT @ 911,"11"
1890 FOR D=13 TO 46 STEP 3
1900 SET(35,D)
1910 NEXT D
1920 FOR E=42 TO 82 STEP 8
1930 SET(E,10)
1940 NEXT E
1950 FOR E=13 TO 47 STEP 3
1960 SET(86,E)
1970 NEXT E
1980 POKE 16526,83:POKE 16527,116
1990 PRINT@1,"**",YY$
2000 NC=40-Z1/66:INPUT"INPUT TIMER,MAX 255,10=3 SEC.";TL
2010 N=NC*256+TL
2020 X=USR(N)
2030 PRINT@1,"**",YY$
2040 INPUT"ENTER 'TIMER LENGTH','1' FOR CHORD RECYCLE,'0' FOR MENU";TL,CR
2050 IF CR=1 THEN 2010 ELSE 500
2060 FOR C=4 TO 6
2070 FOR R=1 TO 11
2080 IF GT(C,R)=N THEN 2710
2090 NEXT R,C
2100 IF XX<1 THEN XX=1
2110 IF XX=1 THEN YY=4
2120 IF ZZ<1 THEN ZZ=1
2130 IF ZZ=1 THEN AA=4
```

Program Listing 1 continues

BIS Bayesian Investment Services

Send \$1.00 for
instructive catalog
with sample output
of TRS-80^{*}
investor programs
written by economist
Dr. Richard Harriff
of BIS.

Stock Timer™
Commodity Timer™
Option Valuator™
Convertible
Valuator™
Portfolio Valuator™

Write or call:

BIS

757 Santa Rosita
Solana Beach, CA 92075
(714) 755-6225

*TRS-80 is a trademark of Tandy Corp.

RUN BASIC PROGRAMS AT SUPER SPEED

WITH ZBASIC 2.2.

THE WORLDS FASTEST TRS-80 BASIC COMPILER from **SIMUTEK**

BELIEVE IT OR NOT WE'VE ADDED MORE NEW FEATURES to the ONLY INTERACTIVE BASIC COMPILER for the TRS-80!

1. Speed increases of 10-100 times are typical after compilation.
2. Compiled code can be RELOCATED to run anywhere in memory. Code is even ROMable!

3. ZBASIC 2.2 NOW SUPPORTS BOTH RANDOM and SEQUENTIAL DISK I/O.

4. ZBASIC 2.2 is now a super tool for business programmers: RANDOM ACCESS FILES, and PRINT USING statements are supported as well as a HIGH PRECISION MATH package (with no rounding problems).

5. Special BUILT-IN MACHINE LANGUAGE COMMANDS to increase program operation by as much as 1000 times! Special commands are implemented for fast memory searching (CPDR, CPR), block memory moves (LDIR, LDDR), inputting and printing HEX numbers, inserting MACHINE LANGUAGE into COMPILED CODE, disabling and enabling interrupts, inverting memory, 16 bit PEEKs and POKES, and stack control, debug and much more.

6. ZBASIC 2.2 compiles the ENTIRE PROGRAM into to Z-80 machine language. (Not 8080 code or a combination of BASIC and machine language like some other compilers.) Clumsy LINKING LOADERS, and RUNTIME MODULES are not needed, ZBASIC 2.2 creates a ready to run MACHINE LANGUAGE program

7. NO ROYALTIES imposed on registered ZBASIC owners.

8. Typical COMPILATION TIME is TWO SECONDS for a 4K program.

9. Use TRS-80 Basic to write ZBASIC programs!

10. Compile many existing programs with only minor changes. (Some BASIC programming experience is required.)

11. Fully compatible with both the Model I and the Model III. Mod I compiled programs work on a MODEL III, and visa-versa. ZBASIC works with NEWDOS-80, NEWDOS+, DOSPLUS, LDOS, MULTIDOS, ULTRADOS, TRSDOS etc

12. BUILT-IN and much improved MUSIC and SOUND EFFECTS commands

13. Improved CHAINING for disk users.

14. TIME\$ now available on DISK version.

15. ZBASIC 2.2 now has an INPUT @ command (similar to PRINT @).

16. The TAB function will now tab 255 columns on a printer. (BASIC cannot tab past column 64.)

17. NEWDOS 80 2.0 USERS can use the CMD "dos command" function!

18. NEW and EASIER to use USR COMMANDS

19. New math functions to calculate XOR and INTEGER REMAINDERS

20. Logical STRING COMPARISONS are now supported

21. The disk commands INSTR, MID\$ ASSIGNMENT are now supported on both DISK AND TAPE ZBASIC.

22. DEFSTR is now supported.

23. Eight disk files may be opened simultaneously; random, sequential or mixed.

24. LINE INPUT#, is now supported

25. Invoke the compiler by simply hitting these two keys. " - "

26. NEW 100+ PAGE MANUAL WITH DESCRIPTIONS AND EXAMPLE

27. ZBASIC 2.2 Comes with CMDFILE/CMD program from MISOSYS, to allow appending or merging compiled programs and machine language programs from tape or disk.

ZBASIC 2.2 DOES NOT SUPPORT THESE BASIC COMMANDS:

1. ATN, EXP, COS, SIN, LOG, TAN, and exponentiation. (However, subroutines are included in the manual for these functions.)
2. ERROR, ON ERROR GOTO, ERL, ERR RESUME.
3. No direct commands like AUTO, EDIT, LIST, LLIST ETC, although these commands may be used when writing programs.
4. Others NOT supported. CDBL, CINT, CSNG, DEFFN, FIX, FRE.
5. Normal CASSETTE I/O. (ZBASIC supports it's own SPECIAL CASSETTE I/O statements.)
6. SOME BASIC COMMANDS MAY DIFFER IN ZBASIC. For instance, END jumps to DOS READY, STOP jumps to BASIC READY etc
7. MEMORY REQUIREMENTS to approximate the largest BASIC program that can be compiled in your machine (at one time), enter BASIC and type: PRINT (MEM-6500)/2. Remember, you can merge compiled programs together to fill memory.

ZBASIC 2.2 SPEED COMPARISON DEMO

To help give you an idea how fast compiled programs are, we have included this demo program:

ZBASIC 2.2 DEMO PROGRAM

Time to compile and run complete program	: 0 MIN. 2 SEC.
BASIC Execution speed MOD 1, LEVEL II	: 7 MIN. 34 SEC.
ZBASIC Execution speed MOD 1, LEVEL II	: 0 MIN. 18 SEC.
BASIC Program size (WITHOUT VARIABLES)	: 895 BYTES
ZBASIC Program size (WITHOUT VARIABLES)	: 2733 BYTES

(Remember that the ZBASIC program includes an 1879 byte sub-routine package.) Program shown exactly as compiled and run in BASIC and ZBASIC.

```

10 '===== ZBASIC 2.2 EXAMPLE PROGRAM AND TIME TEST=====
20 CL@:CLEAR100:DEFINT A-X:DEFSTR Z:DIM AA(64,24),Z(50):RANDOM
30 AA=100:BB=-1000:CC=3:DD=-3:EE=-9999:BT@="START TIME "+TIME@
40 FOR I=1 TO 27 STEP 2 :FOR J=47 TO 1 STEP -3:XX=POINT(I,J):SET(I,J)
50 XX=(I-J)/CC*(7+I+J):XX=ABS(INT(RND(I*J)-AA)+7):RESET(I,J)
60 XX=PEEK(I+J):POKE15360+I+J,J:OUT255,J AND (3*J):XX=INP(I)
70 AB@=STR$(I+J):BA@=LEFT$(AB@,2):AA(I/2,J/2)=VAL(BA@)+AA*3
80 BA@=BA@+RIGHT$(BA@,RND(3)):XX=INSTR(1,BA@,"9"):XX=90R(I*J)
90 BA@=MID$(BA@,2,2):MID$(BA@,1,1)=2:IF XX THEN 100 ELSE CL@
100 IF LEN(BA@)>3 OR SGN(XX)=1 AND ASC(BA@)=32 THEN PRINT"+++";
110 IF PDB(0) 62 THEN TRDN:TROFF:PRINT ELSE XX=NOT(RND(99))+100
120 A@=INKEY$:IF A@="Y" OR A@="y" AND I>120 THEN PRINT"TRUE.."
130 RESTORE:READA,C,Z(J),D:GOSUB170:GOSUB170:GOSUB170:GOTO210
140 NEXT:PRINT":":NEXTI:CLS:PRINT@S12,ST@,"STOP TIME "+TIME@
150 STOP'===== END OF MAIN TEST LOOP =====
160 DATA 12345,-1,"TEST",-9999
170 ON RND(6) GOTO 180,190,200,180,190,200
180 RETURN
190 RETURN
200 RETURN
210 ON RND(9) GOSUB 180,190,200,180,190,200,180,190,200
220 GOTO140
    
```

NOTICE ZBASIC 2.0 OWNERS: you can upgrade your ZBASIC 2.0 for no charge. Just send us your original diskette/cassette and a \$ A.S.E with your registered serial number and copy of your invoice. We will send you ZBASIC 2.2 and updates to your manual.

VISA, MASTERCARD, AMERICAN EXPRESS, C. O. D. ORDERS ONLY

800 528-1149 order line

ZBASIC 2.2 DISK VERSION AND MANUAL	89.95
ZBASIC 2.2 TAPE VERSION AND MANUAL	79.95
ZBASIC 2.2 DISK & TAPE VERSION AND MANUAL	99.99
MANUAL ONLY (APPLIES TO PURCHASE)	25.00

SIMUTEK COMPUTER PRODUCTS INC.

TECHNICAL QUESTIONS PLEASE CALL (602) 323-9391
4897 E. SPEEDWAY, TUCSON, ARIZONA 85712

TRS-80 is tm of Radio Shack, a Tandy Corp.

COMPUTER BOOKS FOR BEGINNERS

Everything you need to know to get started programming your own computer. These handy books of programs and about programming are jammed with easy-to-understand info for beginners. They are crammed with hundreds of tips, tricks, secrets, hints, shortcuts and techniques plus hundreds of tested ready-to-run programs. Our full line includes program books and programming aids for eight of the most popular computers for beginners: TRS-80 Color Computer, APPLE II, IBM Personal Computer, TRS-80, Sharp and Casio pocket computers, including the new TRS-80 PC-2 and Sharp PC-1500

Color Computer

- 101 Color Computer Programming Tips & Tricks, learn-by doing instructions, hints, secrets, techniques, insights, for TRS-80 Color Computer, 128 pages. **\$7.95**
- 55 Color Computer Programs for Home, School & Office, practical ready-to-run software with colorful graphics, 128 pages. **\$9.95**
- 55 MORE Color Computer Programs for Home, School & Office, handy book packed with useful type-in-and-run software, with colorful graphics, for TRS-80 Color Computer, 112 pages. **\$9.95**
- Color Computer Graphics, complete guidebook loaded with tips, tricks, hints, secrets, shortcuts, for making the most of TRS-80 Color Computer video graphics. Learn-by-doing instructions plus complete programs, 128 pages. **\$9.95**
- The Color Computer Songbook, 40 favorite pop, classical, folk & seasonal songs arranged for TRS-80 Color Computer, ready-to-run music programs, 96 pages. **\$7.95**
- My Buttons Are Blue and Other Love Poems from the Digital Heart of an Electronic Computer, for poetry lovers, computer lovers, a hi-tech classic, 66 heartwarming poems written by a TRS-80 Color Computer, 96 pages. **\$4.95**

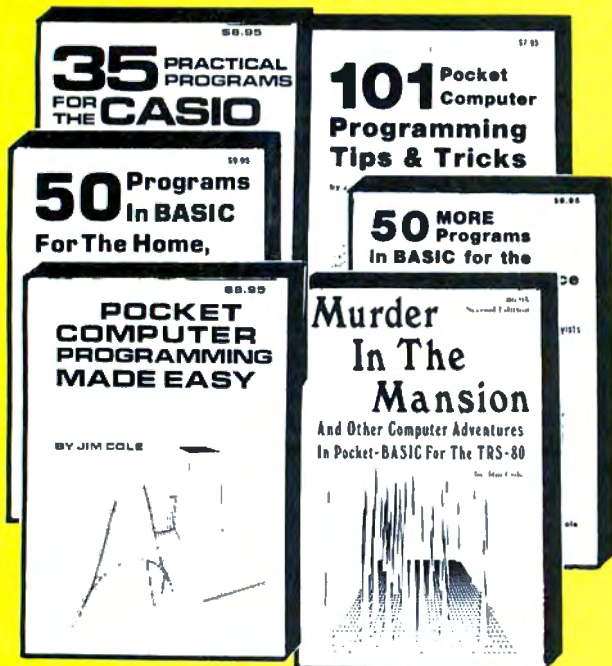
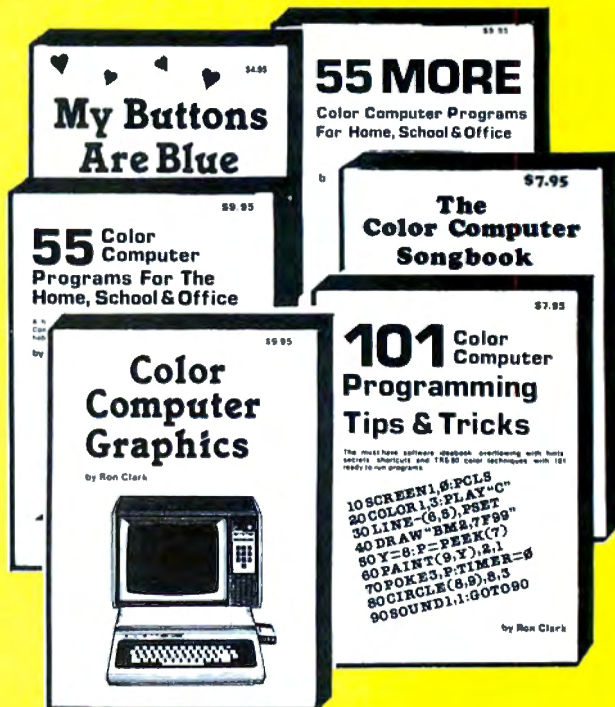

Pocket Computer

- 101 Pocket Computer Programming Tips & Tricks, secrets, hints, shortcuts, techniques from a master programmer, for TRS-80 PC-2, PC-1, Sharp PC-1500, PC-1211 pocket computers, 128 pages. **\$7.95**
- Pocket Computer Programming Made Easy, new fast easy read-and-learn way to make TRS-80 PC-2, PC-1, Sharp PC-1500, PC-1211, Casio FX-702P pocket computers work for you. Learn BASIC quickly; 128 pages. **\$8.95**
- 50 Programs in BASIC for Home, School & Office, useful ready-to-run software for TRS-80 PC-2, PC-1, Sharp PC-1500, PC-1211 pocket computers, 96 pages. **\$9.95**
- 50 MORE Programs in BASIC for Home, School & Office, book of tested type-in-and-run software for TRS-80 PC-2, PC-1, Sharp PC-1500, PC-1211 pocket computers, 96 pages. **\$9.95**
- Murder In The Mansion and Other Computer Adventures, murder mystery, space adventure, 24 games for TRS-80 PC-2, PC-1, Sharp PC-1500, PC-1211 pocket computers, 96 pages. **\$6.95**
- 35 Practical Programs for the Casio Pocket Computer, useful type-in-and-run software for the FX-702P, 96 pages. **\$8.95**

APPLE Computer

- 101 APPLE Computer Programming Tips & Tricks, secrets, hints, shortcuts, techniques, insights, for APPLE II, 128 pages. **\$8.95**
- 33 New APPLE Computer Programs for Home, School & Office, practical ready-to-run software for APPLE II, 96 pages. **\$8.95**

Program Worksheets

Handy printed forms make writing BASIC software easy and fun. Customized for your own computer system, or use the universal form good for any BASIC computer, 40-sheet tablets:

- Color Computer Coding Form **\$2.95**
- Pocket Computer Coding Form **\$2.95**
- APPLE Computer Coding Form **\$2.95**
- IBM Personal Computer Form **\$2.95**
- Universal Coding Form **\$2.95**

Order direct from this ad. Send check or money order. Include \$1 shipping for each item ordered up to a maximum of \$3. Or write for our free catalog. Mail orders to:

ARCsoft Publishers

Post Office Box 132C
Woodsboro, Maryland 21798

(301) 663-4444

Customers outside North America wanting airmail send \$4 postage per book. Foreign customers pay in U.S. dollars. Maryland residents add 5% sales tax. Sorry, no COD. TRS-80 is a trademark of Tandy Corp./Radio Shack. APPLE is a trademark of APPLE Computer Inc.

```

2140 IF BB<1 THEN BB=1
2150 IF BB=1 THEN CC=4
2160 FOR R=XX TO YY
2170 FOR C=1 TO 3
2180 QQ=30060+Z1+C+6*(R-1)
2190 IF GT(C,R)=T THEN 2030
2200 IF GT(C,R)=M THEN 2050
2210 IF GT(C,R)=F THEN 2070
2220 IF GT(C,R)=S THEN 2090
2230 NEXT C,R
2240 FOR R=ZZ TO AA
2250 FOR C=1 TO 4
2260 QQ=30060+Z1+C+6*(R-1)
2270 IF GT(C,R)=T THEN 2910
2280 IF GT(C,R)=M THEN 2930
2290 IF GT(C,R)=F THEN 2950
2300 IF GT(C,R)=S THEN 2970
2310 NEXT C,R
2320 FOR R=BB TO CC
2330 FOR C=1TO5
2340 QQ=30060+Z1+C+6*(R-1)
2350 IF GT(C,R)=M THEN 3010
2360 IF GT(C,R)=F THEN 3030
2370 IF GT(C,R)=S THEN 3050
2380 NEXT C,R
2390 TQ=ASC(N1$)
2400 POKE (30121+Z1),TQ
2410 IFN2$=""THEN TQ=32ELSETQ=ASC(N2$)
2420 POKE (30122+Z1),TQ
2430 IF N4$=""THEN TQ=32 ELSETQ=ASC(N4$)
2440 POKE (30123+Z1),TQ
2450 IF N5$=""THEN TQ=32ELSETQ=ASC(N5$)
2460 POKE (30124+Z1),TQ
2470 IF NC>=10 THEN 2500
2480 POKE (30125+Z1),NC+40
2490 GOTO 2610
2500 IF NC>=20 THEN 2540
2510 POKE (30126+Z1),49
2520 NC=NC-10
2530 GOTO 2470
2540 IF NC>=30 THEN 2580
2550 POKE (30126+Z1),50
2560 NC=NC-20
2570 GOTO 2470
2580 POKE (30126+Z1),51
2590 NC=NC-30
2600 GOTO 2470
2610 GOTO2620
2620 Z1=Z1-66:CLS:PRINT "YOU HAVE NOW STORED";40-Z1/66;"CHORDS, WAIT FOR TH
E FRET DISPLAY!"
2630 RETURN
2640 K=X-1
2650 K=X-1
2660 GOTO 1500
2670 N=Q+K
2680 GOTO1530
2690 T=Q+K
2700 GOTO 1570
2710 O=30060+Z1+C+6*(R-1)
2720 POKE O,35
2730 IF C=4 THENXX=R-2
2740 IF C=4 THEN YY=R+2
2750 IF YY>10 THEN YY=10
2760 IF C=5 THEN ZZ=R-2
2770 IF C=5 THEN AA =R+2
2780 IF AA > 10 THEN AA=10
2790 IF C=6 THEN BB=R-2
2800 IF C=6 THEN CC=R+2
2810 IF CC>10THEN CC=10
2820 GOTO 2090
2830 POKE QQ,84
2840 GOTO2230
2850 POKE QQ,77
2860 GOTO2230
2870 POKE QQ,70
2880 GOTO2230
2890 POKE QQ,83
2900 GOTO 2230
2910 POKE QQ,84
2920 GOTO 2310
2930 POKE QQ,77
2940 GOTO2310
2950 POKE QQ,70
2960 GOTO 2310
2970 POKE QQ,83
2980 GOTO 2310
2990 POKE QQ,84
3000 GOTO 2380
3010 POKE QQ,77
3020 GOTO 2380
3030 POKE QQ,70
3040 GOTO2380
3050 POKE QQ,83
3060 GOTO 2380
3070 Z1=2640:PRINT "STORING CHORDS FOR DISPLAY,ALLOW COMPUTER TO WORK UNTIL
YOU SEE THE FRET DISPLAY":IF NL=0 THEN 580
3080 FOR YL=1 TO NL
3090 M=M(YL):P=P(YL):S=S(YL):N=N(YL):NC=NC(YL):N1$=N1$(YL):N2$=N2$(YL):N4$=
N4$(YL):N5$=N5$(YL):T=T(YL)

```

Program Listing 1 continues

ARE YOU TIRED OF

- Fighting protected disks
- Paying \$5.00 more for your programs
- Wasting a whole disk for 1 program
- Or a program that won't run when you put it to disk? Well, finally ...

VECTOR FIX IS HERE!

- Identifies machine language programs on cassette & loads them into high memory.
- Adds an appendage to patch the keyboard vectors enabling the program to run from disk regardless of the type of DOS.
- Dumps the program to disk or ...
- Allows you to scan in ASCII or HEX - reveals hidden text in upper or lower case. Dump either to printer.
- High speed string search.
- Call 'Debug' & return.
- Also patches relocated Disk versions above 8100 H, thus eliminating special loading procedures.

**32K MODEL I TRS-80
DISK \$19.95**

Personal checks take 15 banking days to clear.
Send check or money order to.

MICRO-MEDIA

P.O. Box 538, Linden, MI 48451

TRS-80*

SAVE A BUNDLE

When you buy your
TRS-80™ equipment!
Use our toll free number to
check our price before you buy
a TRS-80™ . . . anywhere!

TRS-80 is a trademark of the Radio Shack Division of Tandy Corporation

Don't delay . . . CALL TODAY



189

SALES COMPANY

704 West Michigan

P.O. BOX 8098 PENSACOLA FL 32506

904/438-6607

nationwide 1-800-874-1551

"The asterisks across the top of the diagram represent the six strings and those down the sides represent frets."

Program Listing 1 continued

```

3100 GOSUB2060
3110 NEXT YL
3120 FOR B =1 TO 300:NEXT B:GOTO1820
3130 INPUT"4 NOTES, #'S WILL BE SKIPPED MUST BE IN 1 TO 12 FORMAT";T,M,F,S
3140 IF T=0 THEN 3160
3150 T=T+K
3160 IF M=0 THEN 3180
3170 M=M+K
3180 IF F=0 THEN 3200
3190 F=F+K
3200 IF S=0 THEN 3220
3210 S=S+K
3220 IF T>12 THEN T=T-12
3230 IF M>12 THEN M=M-12
3240 IF F>12 THEN F=F-12
3250 IF S>12 THEN S=S-12
3260 GOTO1760
3270 FOR OT=0 TO 6
3280 FOR UM=0 TO 1
3290 IF N1$=WNS(OT,UM) THEN 3310
3300 NEXT UM,OT
3310 N1=VAL(WNS(OT,UM+1)):RETURN
3320 FOR OT=0 TO 6
3330 FOR UM=0 TO 1
3340 IF N6$=WNS(OT,UM) THEN 3360
3350 NEXT UM,OT
3360 N6=VAL(WNS(OT,UM+1)):RETURN
3370 GOTO10
3380 GOTO3370
3390 INPUT "CASSETTE LOAD,READY CASSETTE";X
3400 POKE 16526,4:POKE 16527,117
3410 X=USR(N)
3420 INPUT#-1,YY$,NL
3430 FOR YL=1 TO NL
3440 INPUT#-1,M(YL),F(YL),S(YL),N1$(YL),N2$(YL),N4$(YL),N5$(YL),N(YL),T(YL),
NC(YL)
3450 NEXT YL
3460 GOTO500
3470 INPUT"CASSETTE SAVE,READY CASSETTE";X
3480 PRINT #-1,YY$,NL
3490 FOR YL=1 TO NL
3500 PRINT#-1,M(YL),F(YL),S(YL),N1$(YL),N2$(YL),N4$(YL),N5$(YL),N(YL),T(YL),
NC(YL)
3510 NEXT YL
3520 GOTO500

```

Program Listing 2

```

7453          00100      ORG      7453H
7453 CD7F0A    00110      CALL    0A7FH ;GET TL,NC
7456 226F75    00120      LD      (756FH),HL ;STORE TL NC
7459 210E0A    00130      LD      HL,0A0EH ;INIT. Z1
745C 227175    00140      LD      (7571H),HL ;STORE Z1
745F ED62     00150  INIT   SBC    HL,HL ;INIT M1,N1
7461 227375    00160      LD      (7573H),HL ;STORE M1,N1
7464 227575    00170      LD      (7575H),HL
7467 ED5B7175  00180      LD      DE,(7571H) ;RETRIEVE Z1
746B 21AF75    00190      LD      HL,75AFH ;INIT BOTTOM BLK
746E 19        00200      ADD     HL,DE ;BTM BLK+Z1
746F 11153D    00210      LD      DE,3D15H ;DEST ADDR
7472 014200    00220      LD      BC,0042H ;66 COUNT
7475 EDA0     00230  TRANS  LDI
7477 E2AF74    00240      JP      PO,TIME ;TO TIMER AFTER 66
747A D9        00250      EXX
747B 3E05     00260      LD      A,05H ;TEST N1
747D 217575    00270      LD      HL,7575H
7480 BE        00280      CP      (HL)
7481 2805     00290      JR      Z,REN1 ;5-N1=?
7483 110400    00300      LD      DE,0004H ;IF N1=5 GOTO 44
7486 180E     00310      JR      INCM1 ;INC BY 4
7488 2A7575    00320  REN1  LD      DE,0004H ;GOTO M1 INC
748B 010600    00330      LD      HL,(7575H) ;RESET N1
748E ED42     00340      SBC    BC,0006H
7490 227575    00350      LD      HL,BC
7493 112C00    00360      LD      DE,(7575H),HL ;44 INC

```

Program Listing 2 continues

This portion of the program uses a mapping technique to translate chord names to notes and notes to the matrix of locations representing the guitar fret keyboard. Key is a weighting function that moves the entire chord structure up or down the fret matrix.

The Display portion (line 3070) uses the array elements of each chord to generate a set of addresses to POKE. This creates a screen block of memory for each chord and melody note along with its name and number. Later, the machine language portion calls each screen and superimposes it on the fret matrix for the time specified.

You may repeat a display sequence or return to the menu. The arrays are still intact for saving on cassette or re-displaying unless you select menu item one (Create).

The machine language portion (see Program Listing 2) has three major functions:

- Whenever you select Create, the erase portion of this program clears 40 screen spaces in memory.

- During the Display program, after you have entered a time constant, the program selects screens one at a time and transfers them to video memory. When the timer runs out, that screen is erased and the next one is transferred until all have been displayed.

- During the time delay of each screen, the keyboard is monitored for an H input. If this occurs, a modified screen print occurs, sending the required part of the display to the printer (thanks to Louise Frankenberg in the May 1980 *80 Microcomputing* article "Screenprint").

This program barely fits into a 16K tape system. (Disk users need 32K—read on.) If you modify the program, keep this in mind: Very little room is left between the machine language program and storage space for 40 screens (which starts at the top of available memory) and the Basic program plus variables.

Modifying the Program for Disk

First, use standard sequential file storage techniques for the chord arrays. Second, move the entire machine language portion to the top of 32K memory (look out for TRSDOS "TOP MEM"). Third, change to DEFUSR statements and reference the portion addresses. Fourth, let the Basic portion load where it will. There should be no conflicts if you take care of the first three steps. ■

Edward Louis is employed as a Business Manager by General Electric. He enjoys playing music and painting.

Program Listing 2 Continued

```

7496 2A7375 00370 INCM1 LD HL,(7573H) ;INC M1
7499 19 00380 ADD HL,DE
749A 227375 00390 LD (7573H),HL
749D 11153D 00400 LD DE,3D15H
74A0 19 00410 ADD HL,DE ;NEW DEST ADDR
74A1 227975 00420 LD (7579H),HL
74A4 217575 00430 LD HL,7575H
74A7 34 00440 INC ;INC N1
74A8 D9 00450 EXX
74A9 ED5B7975 00460 LD DE,(7579H) ;UPDATE DEST ADDR
74AD 18C6 00470 JR TRANS
74AF 3A6F75 00480 TIME LD A,(756PH) ;TIMER
74B2 47 00490 LD B,A
74B3 11FFFF 00500 LP1 LD DE,0FFFFH
74B6 21DE39 00510 LD HL,39DEH
74B9 19 00520 LP2 ADD HL,DE
74BA 38PD 00530 JR C,LP2
74BC CD2775 00540 CALL SCRIP ;INPUT KEY
74BF 10F2 00550 DJNZ LPI
74C1 21153D 00560 LD HL,3D15H ;IST ERASE ADDR
74C4 3620 00570 ERASE LD (HL),20H ;'SPACE'
74C6 227775 00580 LD (7577H),HL ;XFER DEST ADDR
74C9 ED5B7775 00590 LD DE,(7577H) ;TO DE
74CD 13 00600 INC DE
74CE 011400 00610 LD BC,0014H ;20 COUNT
74D1 EDB0 00620 LDIR
74D3 012D00 00630 LD BC,002DH
74D6 09 00640 ADD HL,BC
74D7 227775 00650 LD (7577H),HL ;NEW S.A. TO MEM
74DA ED4B7775 00660 LD BC,(7577H) ;NEW S. A. TO BC
74DE 11F93F 00670 LD DE,3FF9H ;END BLOCK
74E1 ED52 00680 SBC HL,DE ;COMPARE TO EXTANT ADDR
74E3 FAEB74 00690 JP M,AA16 ;TO SOURCE ADDR REST.
74E6 1805 00700 JR END ;TO END ROUTINE
74E8 ED62 00710 AA16 SBC HL,HL ;REST. SOURCE ADDR
74EA 09 00720 ADD HL,BC ;TO NEXT ERASE SEG.
74EB 18D7 00730 JR ERASE
74ED 2A7175 00740 END LD HL,(7571H) ;RETRIVE Z1
74F0 114200 00750 LD DE,0042H
74F3 ED52 00760 SBC HL,DE ;Z1-66
74F5 227175 00770 LD (7571H),HL ;SAVE NEW Z1
74F8 2809 00780 JR Z,RET ;TO RET WHEN DONE
74FA 217075 00790 LD HL,7570H
74FD 35 00800 DEC (HL) ;DEC. CHORD COUNT
74FE 2803 00810 JR Z,RET
7500 C35F74 00820 JP INIT ;TO NEXT CHORD
7503 C9 00830 RET
7504 217D75 00840 BLK LD HL,757DH
7507 3620 00850 LD (HL),20H ;'SPACE'
7509 227775 00860 LD (7577H),HL ;TRANS ADDR
750C ED5B7775 00870 LD DE,(7577H)
7510 13 00880 INC DE ;NEXT ADDR
7511 01820A 00890 LD BC,0A82H ;BLK LENTGH
7514 EDB0 00900 LDIR
7516 C9 00910 RET
7527 00920 ORG 7527H
03E3 00930 KEYSN EQU 03E3H
3802 00940 KEYS EQU 3802H
4016 00950 KYPNTR EQU 4016H
4026 00960 PRPNTR EQU 4026H
7527 2A2640 00970 SCRIP LD HL,(PRPNTR)
752A 225C75 00980 LD (PR1+1),HL
752D 226475 00990 LD (PR2+1),HL
7530 3A0238 01000 ENTRY LD A,(KEYS)
7533 FE01 01010 CP 01H
7535 C0 01020 RET NZ
7536 F5 01030 PUSH AF ;SAVE REGISTERS
7537 C5 01040 PUSH BC
7538 D5 01050 PUSH DE
7539 E5 01060 PUSH HL
753A 21803C 01070 LD HL,3C80H ;START OF SCREEN MEM
753D 160D 01080 LD D,13 ;NUMBER OF LINES
753F 0640 01090 NXTLIN LD B,64 ;LENGTH OF LINE
7541 4E 01100 NXTCHR LD C,(HL) ;GET CHAR TO BE PRINTED
7542 3E5F 01110 LD A,5PH
7544 91 01120 SUB C
7545 3809 01130 JR C,SUS
7547 79 01140 LD A,C
7548 0E20 01150 LD C,20H
754A 91 01160 SUB C
754B 3807 01170 JR C,CK
754D 4E 01175 LD C,(HL) ;PUT CHAR. BACK
754E 180B 01180 JR PRL
7550 0E2A 01190 SUS LD C,2AH
7552 1807 01200 JR PRL
7554 7E 01210 CK LD A,(HL)
7555 FE0D 01220 CP 0DH
7557 280A 01230 JR Z,PR2
7559 18F5 01234 JR SUS
755B CD0000 01240 PRL CALL $-$
755E 23 01250 INC HL ;NEXT ADDR
755F 18E0 01260 DJNZ NXTCHR ;DO UNTIL WHOLE LINE DONE
7561 0E0D 01270 LD C,0DH ;CARRIAGE RET.
7563 CD0000 01280 PR2 CALL $-$ ;GOTO PRINTDRIVER
7566 15 01290 DEC D
7567 C23F75 01300 JP NZ,NXTLIN ;GO START NEXT LINE
756A E1 01310 POP HL ;RESTORE REG'S
756B D1 01320 POP DE
756C C1 01330 POP BC
756D F1 01340 POP AF
756E C9 01350 RET ;BACK TO GUIT TIMER
0000 01360 END
00000 TOTAL ERRORS

```

We will meet or beat any price in the U.S.A. on

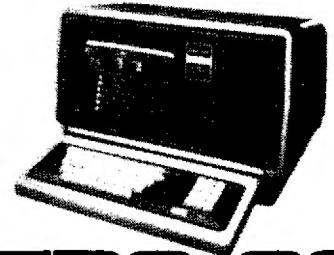

TRS-80 MICROCOMPUTERS

In fact, no matter what price you see advertised by Texas Computer Systems, Micro Management, Computer Plus, Pan American, or any authorized Radio Shack dealer for TRS-80 Computers with pure factory installed memory and full warranty, we'll beat it!

ATARI® MICROCOMPUTERS

We have consistently offered the best prices on
APPLE • COMMODORE VIC-20
OKIDATA • MICROLINE
EPSON • WABASH • MAXELL
 — plus a complete line of Diskettes, Monitors, Modems and other accessories — all at the best delivery from the largest inventory in the Northeast.

If you're looking for the best prices in the U.S.A., check the others, but call Computer Discount of America.

TRS-80 and Radio Shack are trademarks of Tandy Co.

Write or call for FREE Computer Catalog with pictures, specs, accessories and prices.

CALL TOLL FREE:
800-526-5313



COMPUTER DISCOUNT OF AMERICA, INC.
 15 Marshall Hill Road, West Milford NJ
 West Milford, New Jersey 07480-2198
 In New Jersey Call 201-728-8080

The wonderful, weird world of Dennis Kitz.

Divine Dementia

by Michael Nadeau
80 Microcomputing staff

If it wasn't for a broken synthesizer and a copying machine, *80 Micro* readers might never have heard of Dennis Kitz, our "80 Applications" author and general technical wiz.

You see, Dennis never intended to get into computers; he considers himself a musician first and foremost. But it was music that introduced him to computers. Music led Dennis to take a job as a typist because he would have unlimited use of a copying machine to reproduce his compositions. The copier brought him to *80 Micro*.

Dennis Bathory Kitz graduated with a BA in music with a French minor from Rutgers University in 1970. A year earlier he wrote his first electronic musical composition—a 17-part piece which he had no way

to produce. Dennis decided then that he needed a synthesizer, but, he said, "I was so desperately poor in those days that \$1,500 to \$2,000 was out of the question."

He was finally able to buy a synthesizer in 1973, and within two months the power supply blew. The \$100 repair bill prompted Dennis to vow never to send out any electronic equipment to be fixed again.

"I read every electronics book I could get," he said. Though he had a basic understanding of electronics, a subscription to *Popular Electronics* proved to him he had missed out on the digital electronics revolution. "I had no idea what those little black boxes were," he said. By stubbornly reading the technical literature and fixing other things that blew up, Dennis learned what he needed to know about his synthesizer.

But the little black boxes were still a mystery. When an order for a sequencer for his synthesizer was stopped due to the bankruptcy of the manufacturer, Dennis decided to build one. He knew he had to learn digital electronics to do so, and reacted by subscribing to *Byte*. "I understood none of it, but I decided to keep going and the light would dawn," Dennis said. That persistence eventually paid off.

This new-found knowledge and his nagging poverty were the reasons Dennis found himself working at the local Radio Shack store doing repairs on a variety of electronic gadgetry. He worked on commission plus the minimum wage (about \$2.65 per hour in 1975), but this experience resulted in Dennis buying one of the first TRS-80 Model I's.

The Original Warranty Voider

When the Radio Shack store where he was working received the preliminary product information for the Model I (so sketchy

he described it as "comical"), Dennis decided to risk putting the required \$100 deposit down on one even though he "didn't know what to do with it."

To the amazement of the other store clerks, Dennis immediately opened the computer up when it arrived after unpacking it at the store. This action may have made him the original Radio Shack warranty voider, a title that somehow seems appropriate.

Dennis' history after his stay at the Radio Shack store is a mixed bag. He drove a truck for a while, worked in a chamber of commerce, and edited an underground newspaper. In 1976 he was "the youngest and poorest" trustee of the New Jersey State Museum.

In 1978 he moved to Roxbury, VT, his current home, leaving a "lucrative" job as a graphics designer. In Vermont, Dennis



Pinned by his dog, Fritz.



Claire takes aim at Dennis and his computers.

YOU'VE GOT OUR NUMBER (800) 525-8419

Shannon Magnetics PLUS DISKETTE

New from Shannon. Their top-of-the-line, state-of-the-art, soft-sectored 5¼" double density, single sided, mini disk with **hub rings**. Boxes of 10 shrink wrapped with jackets, labels and tabs.

Probably the only disk with an unlimited, lifetime guarantee. Shannon Magnetics finest quality with Premex certification. List \$29.95. Box of 10. Introductory offer \$24.95.

Mini Diskettes

Box of 10 \$26.95 2 boxes \$39.96
Shannon Magnetics' soft-sectored 5¼" double density, single-sided, mini disks in shrink wrapped boxes of ten with jackets, labels and tabs. Fully guaranteed for one year against defects.

Headcleaner Kit

\$24.95

Verfin kit contains two cleaning disks with instructions to assure proper operation of all types of 5¼" disk drives. Removes dirt and debris which can cause read/write errors and lost data without harsh chemicals.

Diskette/Headcleaner Combo

\$42.90

Combo special includes box of 10 diskettes and Verfin headcleaner kit as described above.

Dysan diskettes

Single density \$36.95 Double density \$39.95
Dysan 40 track 5¼" soft sectored diskettes packaged 10 to a box.

Paper

White or Green Bar
3300 sheets of 9½ X 11" tractor feed \$29.95
3300 sheets of 14" X 11" tractor feed \$39.95
Shipped by truck, freight charges collect.

Diskette File Box

\$19.95

Flipsort diskette file box with capacity for fifty 5¼" diskettes.

Diskette/File Box Combo

\$109.95

Fifty Shannon Magnetic 5¼" diskettes as described above packaged in Flipsort diskette file box.

Tandon Disk Drives for TRS-80 Model I or Model III

Single drive with cabinet and power supply	\$289.00
Two drives in horizontal cabinet and power supply	\$489.00
Two drive cabinet only	\$75.00

Two drive cabinets are designed to fit under Epson or Okidata printer or under the monitor and above the expansion interface with provision for easy access to drive edge card connections. No drive extender cables needed. Call for complete pricing and compatibility information.

Ribbon Cables

Model I or III printer	\$18.95
2-drive disk cable	\$19.95
4-drive disk cable	\$29.95



304 Elati
Denver, CO 80223
(303)-698-1186

To order call toll free: 800/525-8419

Mastercard and Visa welcome
Checks & Money Orders also accepted
Orders shipped UPS free

Colorado residents add
6½ per cent sales tax
Attractive discounts to dealers

OMNITEK COMPUTERS 195
INTERNATIONAL, INC.
1899 MAIN STREET
TEWKSBURY, MASS
617-851-4580

RS232 Direct Connect Modems.	99.00
Scotch S.S.D. 5 25" Diskettes.	25.00
Verbatim 5 25" D.L.	25.00
16K RAMKITS.	14.00
TECO 12" B&G Monitor.	119.00
Okidata Microline 80.	329.00
Okidata Microline 82A.	449.00
Okidata Microline 83A.	699.00
Epson Mx-80.	479.00
Epson MX-80 FT.	579.00
Radio Shack Mill w 48K.	879.00
Radio Shack Mill w 48K and 2 40T dr	1699.00
40 track 5 25" Tandon TM-100-1.	284.00
80 track 5 25" Tandon Dual Head.	484.00
5.25" Power Supply and case.	49.00
8" Power Supply and case.	99.00
CENTRONICS 739 Printer.	499.00

TRS 80 is a registered trademark of
Tandy Corp

Prices are for mail order only
 TERMS: Check, money order, Mastercard
 and Visa accepted. F.O.B. Tewksbury-
 freight extra. Mass residents add 5%
 sales tax. Write for FREE CATALOG

TRS-80™ Model 1 & 3

SYSTEM DIAGNOSTIC \$99.95
 Tests for every component of your TRS-80
 Model 1 or 3: ROM, RAM, Video Display,
 Keyboard, Line Printer, Cassette Recorder,
 Disk Drives, RS-232 Interface.

SMART TERMINAL \$69.95
Model II Version (CP/M only) ... \$79.95
 The intelligent telecommunication program.
 Automatic transmission and reception
 of data. True BREAK key. Complete
 character mapping, lower case. Cassette
 and disk files compatible with both
 SCRIPSIT™ and Electric Pencil™.

MONITOR #4 \$49.95
 Disassembler; memory displays; move,
 search, modify memory; read and write
 machine language cassettes; object code
 relocater; hexadecimal arithmetic; disk
 file and sector input and output; RS-232
 communications. (Models 1 and 3 only.)

SMALL BUSINESS ACCOUNTING
Disk version \$49.95
Cassette version \$29.95

Based on Dome Bookkeeping record,
 keeps track of income, expenditures, and
 payroll for small business (up to 16 em-
 ployees). Cassette version does not
 contain payroll.

Specify Model number
 Send S.A.S.E. for FREE Catalogue
 Add \$3.00 for postage and handling.

HOWE SOFTWARE
 14 Lexington Road, New City NY 10956
 (914) 634-1821 175
 TRS-80 is a registered trademark of Tandy Corp.

*“(Dennis) was the
 ‘youngest and poorest’ trustee
 of the New Jersey State Museum.”*

found the time to work with his Model I. He had learned Basic in one night soon after he bought the computer, but did not think Assembly language was necessary—until he started playing with model trains.

Dennis and a friend, David Gunn, designed an elaborate set-up for a model train track in Dennis' living room. Dennis wrote a Basic program to control the track switching and other railroad paraphernalia. When they started the train running, it was immediately obvious that the program was too slow for the train.

Dennis had plans to eventually produce his musical compositions using a computer. His experience with the train set proved to him that Basic would be too slow for music as well—he had to learn Assembly language.

Assembly language did not come quite as easily as Basic; it took Dennis six months of deciphering the Zilog mnemonics manuals before he wrote a program that worked. The second Assembly language program he wrote appeared in the June 1980 issue of *80 Micro*, entitled “Playing God with Life.” “I learned fast,” he said.

Dennis credits his friend, the late Dr. Phil Hooper, with the breakthrough that made the Assembly light dawn. Dr. Hooper brought an early micro (a KIM-1 by Moss Technology) to Dennis to have the monitor repaired. The KIM-1 had a hexadecimal digit keyboard; by using that machine and with instruction from Dr. Hooper, Dennis became a machine-language programmer.

Fame and Fortune with 80 Micro

Up to this point Dennis' expertise had not been exposed to the general computer public. Enter one copying machine.

It was not long before Dennis again found himself in dire financial straits. His main source of income was a hi-fi repair business, but there were not many hi-fis that needed fixing in northern Vermont.

Out of desperation he answered an ad seeking a typist. Dennis was not enthusiastic about typing for a living, but he thought if the material he would be typing was interesting, he would take a shot at it.

He called the number in the ad and was told the job was essentially typing proposals for a state agency. He did not consider this to be particularly interesting and was about to hang up when the woman he was speaking to asked how fast he typed. “Oh, about 110 words per minute,” he answered.

She didn't believe Dennis could type that

fast and convinced him to take a typing test, if for no other reason than to prove he was a 110-word-per-minute typist. He did a little better than 110 wpm on the test and was offered the job, which he was about to turn down when the interviewer told him all employees had access to the copying machine.

Dennis' thoughts flashed to his piles of musical compositions that he needed copies of, and without hesitation he accepted the job.

He soon thought of another use for the copier: making copies of the programs he had written. At this time (over two years ago) *On-Line* magazine was providing free classified ads. Dennis placed a two-line ad offering a 1K machine-language monitor program if you sent him a self-addressed stamped envelope.

One of the people who sent for this program was *80 Micro's* then managing editor Jim Perry. Perry called Dennis and said, “This is interesting, got anything else?”

Dennis said he had something he called “Babybeep,” which should be familiar to many long-time *80 Micro* readers. But at that moment, a thought crossed Dennis' mind. “By the way, I'd like to write a column for you,” he told Perry.

To Dennis' surprise, Perry immediately agreed and asked what he would like to call it. Dennis said the first thing he thought of, “80 Applications.” This presented a problem to Dennis because he had no idea what he was going to write.

But he did manage to come up with something and “80 Applications” is now one of *80 Micro's* most popular columns.

A Multi-faceted Person

As already mentioned, Dennis' background is in music. He has written and performed several avant-garde (he hates that term) operas. One, entitled “Plasm Over Ocean” was performed at the New Jersey State Museum in 1977. Not only did Dennis compose the music and play the lead character, he also made every instrument and designed the cast's wardrobe. The instruments were not readily recognizable as standard musical instruments (except the gong, which took the longest time to make and was used only once). One, a glass cello, looks like something out of a Hieronymous Bosch painting.

The production was performed by the Laszlo Toth School of Music, named after the man who attacked the Pieta with a hammer in the Vatican.

TRS/80 Models I or III

Lists or quantity ONE prices are:

- DATA ACE User Guide \$30.00
- MMSFORTH \$125.00
- DATA ACE DBM - database accesses, data definition language, editor and catalog and User Guide - \$150.00
- Query language - \$100.00

(MMSFORTH is a prerequisite for DATA ACE, DATA ACE DBM is a prerequisite for DATA ACE Query language.)

Existing MMSFORTH users may obtain the complete DATA ACE package for \$250. Those using MMSFORTH for the first time will be investing \$375.00.

(MMSFORTH IS A TRADE MARK OF MILLER COMPUTER SERVICES.)

TRS/80 Model II

For \$75 you get a User Guide and a demonstration disk. Once you know what you want, you may choose the exact package for your needs. DATA ACE is also available for hard disk and with application start up kits.

For dealers, quantity discounts are available, substantially reducing the above prices.

DATA ACE is a smart and completely integrated system - operating system, relational data base manager, query language, structured programming language, full screen editor, catalog, application packages and commitment to future development.

BUILD YOUR SYSTEMS IN LESS TIME, AT LESS COST, TO RUN FASTER.

Build your files faster

Data should be separate from the programs - why?

First of all, you can change your programs without affecting stored data. Secondly, you can set up your data files in their most natural form and when needed, change them without changing your programs. Finally, the process of setting up files can be reduced to a simple keyboard request "ADD RELATION".

GET IT UP QUICKER

ONCE YOUR FILES ARE DEFINED, START RECORDING DATA IMMEDIATELY

DATA ACE enables you to maintain these files without writing a single program!

You may add a record with a simple keyboard command "ADD". CHANGE, DELETE or LIST a record in the same way. A complete keyboard language has been developed which can, for example, find all customers in a given area, with open orders that are back-logged . . . without writing a program! This is done using logical and relational operators - almost as many of these as you want.

FOR REAL COMPLEXITY, GO AHEAD AND WRITE A PROGRAM, BECAUSE. . .

DATA ACE makes it really easy: Full screen editor with a wide range of word processing commands.

Catalog complex commands or text for later use simply by name. **Self documenting** with HELP text for each field, contextual HELP in the QUERY language, or you may write you own HELP TEXT for your systems and change it without going to the programs. **Structured design** with a clear set of guide lines.

AND WATCH HOW FAST WE GO

Competitive analysis shows DATA ACE to outperform every other DBM on 8 or 16 bit computers, yet DATA ACE includes much much more. Benchmarks have shown DATA ACE to run approximately TEN times faster than BASIC.



YES- show me more / send me

- the DATA ACE Model II User Guide and demonstration disk \$75.
- the DATA ACE - Model I/III User Guide \$30.
- a copy of MMSFORTH \$125.
- a copy of DATA ACE DBM \$150.
- a copy of DATA ACE Query Language \$100.

Enclosed is my check/credit card details. (We accept Visa or M/C)

card no. exp. / /

NAME

COMPANY

ADDRESS

CITY

STATE ZIP

TELEPHONE

COMPUTER SOFTWARE DESIGN INC
1911 WRIGHT CIRCLE,
ANAHEIM, CA 92806
714/634 9012

"(Dennis') house . . . looks like a cross between a frat house after a scavenger hunt and an overstocked electronics workshop."



Dennis and his glass cello as Maximus in "Plasm Over Ocean."

Another of Dennis' productions, "Stone World Grey," so shocked the audience that a number left for fear of losing their lunches. In one scene, a female figure walks toward the stage from in back of the audience to a slow drumbeat. When she reaches the stage, the other characters appear to worship her . . . and then they eat her fingers.

Actually, they ate two very realistically made cake hands. A flesh-colored frosting covered a blood-red cake. A cloak covered her arms, so it appeared she was stretching out her own hands.

Dennis also fancies himself a photographer. He won an award for a photo that he claims was an accident. The photo focuses on a doll hung upside-down with darts sticking in it. A friend stands in the background with a mysterious expression on her face. Dennis was just photographing the doll, which at the time seemed funny, but he accidentally captured his friend in an interesting juxtaposition to the doll.

One of Dennis' long-term goals is to build and market a digital synthesizer for under \$2,500. Such a synthesizer runs in the \$15,000 range today, but Dennis is convinced he can produce one much cheaper.

The Character

Dennis is a frugal individual. He still drives the car he bought new in 1964, a Plymouth Vallant. The car had over 220,000



The cast of "Stone World Grey": Richard Fredette, Pamela Ritterbusch, David Gunn, and Dennis.

miles at last count, and it looks like it earned every mile. Twit, as its license plate reads, is also an unwelcome sight at the local Midas dealer. Dennis had one of their mufflers installed some years ago; he has been back about seven times for replacements.

The house he and his wife, Claire, share with two cats and a dog looks like a cross between a frat house after a scavenger hunt and an overstocked electronics workshop. Shelves sag with containers of screws, diodes and other assorted electronic doodads. One is struck by the fact that few of his gadgets have covers on them. Dennis probably became tired of taking them off and putting them back on long ago.

The non-electronic flora and fauna all look equally out of place. He still has his Christmas tree from several years ago,

though it has no branches. ("You're supposed to trim the tree, aren't you?" he claims.) Nestled amongst the instruments he made for "Plasma Over Ocean" are two stuffed ducks, a Jerry Lewis Telethon display, and a bowl of ceramic fruit. One comes to expect the unexpected after a short while in the Kitz home.

The End?

Dennis has been talking of "retiring" from work with microcomputers, but as of this writing the decision is still uncertain. He has received a great deal of feedback from readers of "80 Applications" to continue writing about the Color Computer, and he seems inclined to continue writing Color Computer articles on a restricted schedule. *80 Micro* just wouldn't be the same without Dennis Kitz. ■



The family fleet: Loon and Twit.

ELECTRIC SPREADSHEET™

NEW Considering VisiCalc™?

ELECTRIC SPREADSHEET does everything you can do with a pencil, paper and calculator. Start with a blank screen. Move the fast cursor to desired location. Enter line or column labels or data. Select preprogrammed operators for line, column, or cell calculations. Run. Results appear on the screen, formatted for your printer. Revise. Run again.

PREPROGRAMMED OPERATORS for mathematics, finance, and statistics. Save data on tape or disk. The screen is your window to a larger spreadsheet. Output features scrolling and split-screen. Variable formats for labels and data.

UNLIMITED APPLICATIONS. P/L forecast. Personal budget. Real estate investment. Net worth forecast. Invoice. Cash flow estimate. Sales analysis. Check record. Business forms.

16K version has 50 operators. 32/48K version has 70 operators plus histogram plot, remote storage of data, global revise spreadsheet layout, alpha entries, and more.

16K Model I or III Tape \$34.95
 32/48K Model I or III Tape \$64.95
 48K Model III Disk \$67.95

YOU CAN'T LOSE! Calif. orders add 6½% tax.

VisiCalc is a trade mark of Personal Software, Inc. 511

Dan G. Haney & Associates, Inc.
 P.O. Box 687, San Mateo, CA 94401
 (415) 493-4094

ATLANTIC CABINET

P. O. Box 100, 528
 Williamsport,
 Maryland 21795

50" Split-Level Work Station



RETAIL PRICE

\$195

- A range of work stations designed specifically to house all micro-computers.
- Delivered heavily packed, in self-assembly form needing only a Phillips screwdriver and a few minutes of your time to assemble.
- Manufactured from 1" all wood particleboard surfaced with hard-wearing melamine veneer, in either Oak or Walnut.
- Dealer and Distributor prices on request.
- For more information write or call 301-223-8900.

THE STOCKING SOURCE

MAGIC SHOW

transform your computer...

into a Word Processing or Data Processing System by adding one of the NEW Okidata Printers

If you require a system printer, the new Okidata Microline 82A, 83A, 84 should be your choice.

These printers feature:

- 9 x 9 Dot Matrix heads rated at 200 million characters continuous duty - true lower descenders
- Full forms control - vertical tab, top of form
- Block Graphics
- Bidirectional, Short Line Seeking
- Dual Interface - Parallel & RS-232C Serial

	LIST
Microline 82A - 80-column, 120 characters per second	\$ 649.
Tractor Optional	\$ 50.
Microline 83A - 126-column, 120 cps, built-in tractor	\$ 995.
Microline 84 - 126-column, 200 cps, built-in tractor	\$1395.
Optional Serial Interfaces - RS-232C:	
HS-RS232 - 256 CharacterBuffer	\$ 130.
HS-RS232 - 2K CharacterBuffer	\$ 150.

NEW OKIGRAPH HIGH RESOLUTION GRAPHICS KITS	
FOR MODEL 82A & 83A	\$99.00 List
DUMP ROUTINE DISK	\$65.00 List



ASK FOR OUR INSTANT DISCOUNT From Roy Hawthorne Talk To Bill Tokar On Applications

CALL TOLL FREE U.S.A.
 1-800-521-2764 MICHIGAN
 1-800-482-8393

Remember: We are open 8:30 AM to 6:00 PM EST Monday - Friday

master charge VISA
 No Credit Card Penalty

"The Stocking Source" 24069 Research Drive Farmington Hills, MI 48024 313-474-6708 8

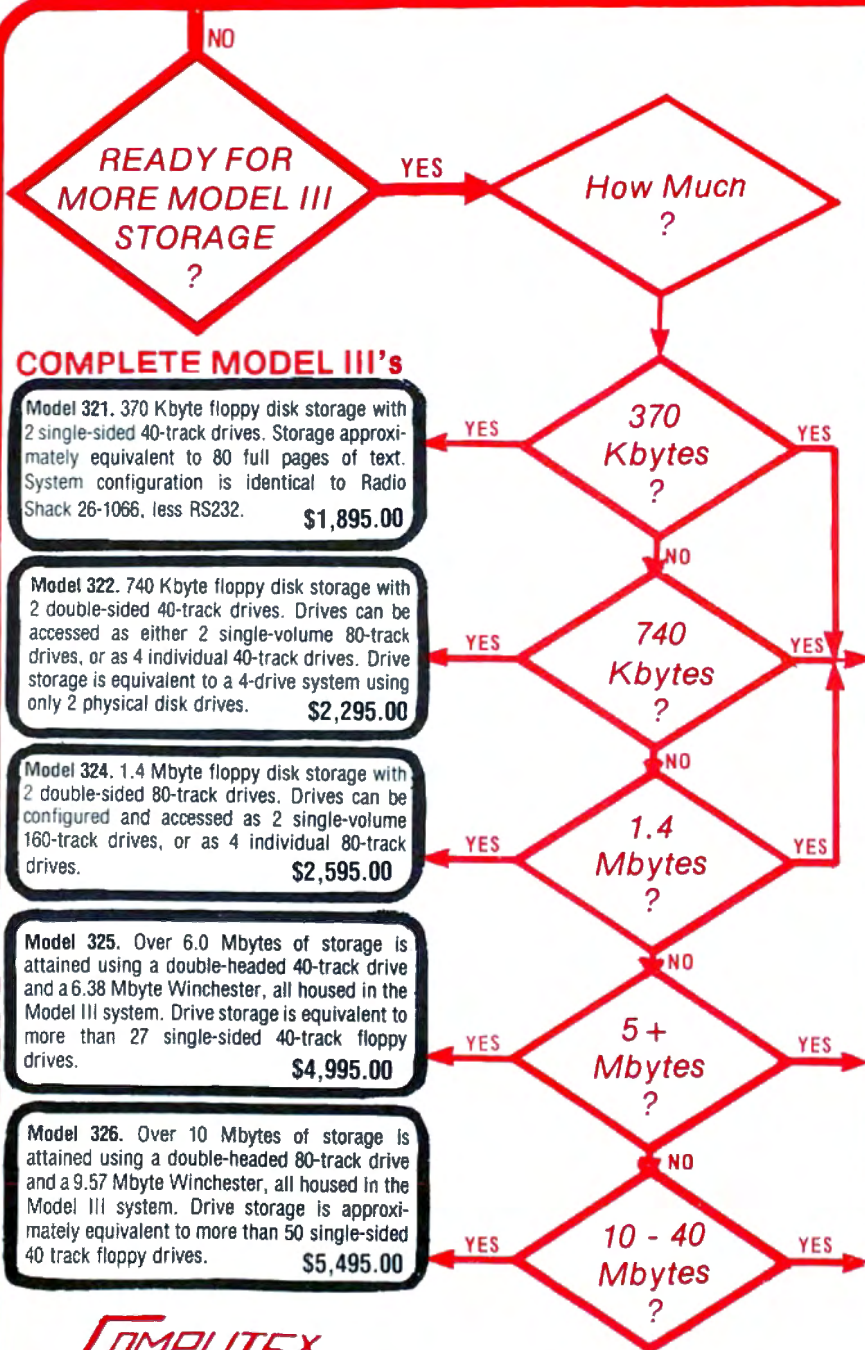

New! Computex Drive Controller PCB with Winchester Option

We've done it! Computex has developed a new disk drive controller PCB with built-in Winchester Option—and the add-on kits—that make it possible for you to upgrade your Model III to 40 Mbytes one step at a time.

HERE'S HOW.

1) Start with the Computex PCB and manual. 2) Add components—your own, or ours—or select a Computex-assembled board. 3) Install into your Model III with our installation accessories kit. 4) Add one or more Tandon TM100 series disk drives. Your floppy disk system is now operational! At every step, Computex backs you up

with service & maintenance.

M3DC1-1B Computex Disk Drive Controller PCB With Winchester Option. PCB solder-masked and silk-screened • gold-plated edge card connectors • Built-in digital write precomp/data separation • step-by-step detailed assembly /installation manual written for the beginner in kit building, includes complete parts list if you choose to buy your own components, detailed best/trouble-shooting instructions..... **\$49.95**

M3DC1-1M Manual only. Refundable on purchase of any M3DC1 components kit or assembly **\$ 7.95**

Computex Floppy Drive Controller Add-On Kits

Begin enjoying the use of disk drives in your Model III immediately. Computex floppy disk controller kit includes all required components and instructions to complete the floppy disk portion of the PCB. (You can buy the controller assembled.) Add Winchester drives later.

M3DC1-1K-Model III Drive Controller Kit includes PCB and manual, plus all components needed to assemble drive controller board. (Does not include TRSDOS and manual..... **\$129.95**

M3DC1-1KA Assembled Kit, Model III floppy drive controller board. Includes TRSDOS manual. **\$249.95**

M3DC1-AK - Accessories Kit for floppy drive installation. Includes switching power supply and brackets. **\$129.95**

NOTE: A complete floppy disk drive system requires: 1) an assembled disk controller board (M3DC1-1B, M3DC1-1K, or M3DC1-1AKA); 2) a M3DC1-AK accessories kit; and, 3) your choice of Tandon TM100 series floppy disk drives. (The accessories kit is not required if you plan to go directly to a Winchester drive.)

SAVE UP TO \$100.00. With your purchase of a Computex drive controller (assembled or in kit form). We will give you a certificate for a 10% discount on any two Tandon TM100 series bare disk drives.

Computex Winchester Controller Add-On Kits

You can add up to 40 Mbytes of Winchester storage via the Computex disk controller board. You will need a Computex Host Adaptor Kit, an accessories kit, and a western digital WD1000 Winchester Drive Controller (available from Computex), and a Winchester Disk Drive to make the system operational.

M3WHA-1 WINCHESTER HOST ADAPTOR KIT. Includes DOS+ 4.0 Winchester Operating System • Winchester Host Adaptor for M3DC1 • All required data cables • Installation, theory and assembly manual **\$499.95**

M3WAK-1 WINCHESTER ACCESSORIES KIT. Includes mounting brackets hardware for floppy and Winchester drives • Winchester switching power supply • All required power cables **\$249.95**

M3WDC-1 DRIVE CONTROLLER. Western Digital WD1000 Winchester Drive Controller **\$595.00**

M3WIM-1 MANUAL. Includes drawings, graphs, and schematics (except Host Adaptor schematics which are proprietary and NOT available) • complete technical information on installation, assembly, testing, trouble-shooting, operation theory • probably the best manual on Tandon Winchester disk drives available today. • Purchase price fully refundable on purchase of M3WHA-1 **\$99.95**

SAVE UP TO \$260.00! With your purchase of our Host Adaptor Kit, you will receive a 20% discount on the purchase of a 5 or 10 Mbyte Tandon Series TM600 Winchester drive from Computex.

COMPUTEX

TANDON TM 600 WINCHESTER DRIVES

• Highest storage capacity of any 5¼" high-speed random access drive • Up to 46 Mbytes online storage • Up to four TM600's can be daisy-chained on single bus • S-version compatible - Shugart SA1000 and Seagate ST506.

TM602S 3-ms access time - 612 tracks - 5 Mbytes/sec data transfer rate - 6.38 Mbyte RPM capacity (unformatted) **\$1,195.00****

TM603S 3-ms access time - 918 tracks - Mbytes/sec data transfer rate - 9.57 Mbyte RPM capacity (unformatted) **\$1,295.00****

****Save up to \$260! Receive 20% discount with certificate of purchase of Computex Winchester Host Adaptor Kit M3WHA-1.**

TANDON TM100 SERIES FLOPPY DRIVES

• Fast 3-5-ms track-to-track access time • Single or double density operation • Total compatibility with Model I or III • Pre/post testing during 48-hour burn-in • 90-day limited warranty.

TM100-1 - Single-sided 40-track drive - 102 Kbytes single density 180 Kbytes double density **\$235.00***
TM 100-1 with power supply & case. **.\$299.95**

TM100-2 - Double-sided 40-track drive - 204 Kbytes single density - 360 Kbytes double density **\$335.00***
TM 100-2 with power supply & case. **.\$399.95**

TM100-3 - Single-sided 80-track drive - 204 Kbytes single density - 360 Kbytes double density **\$335.00***
TM 100-3 with power supply & case. **.\$399.95**

TM100-4 - Double-sided 80-track drive - 408 Kbytes single density - 735 Kbytes double density **\$435.00***
TM 100-4 with power supply & case. **.\$499.95**

*** Save up to \$100. Receive 10% discount with certificate of purchase of any Computex M3DC1.**

Computex Expansion Systems with Disk Drives

Built using the new Computex Model III drive controller board. The full range of drive expansion kits from Computex represent the best design, reliability and expandability of any system currently available. Features include: • Drive Controller with Winchester Host Adaptor expansion option • Switching Power Supply (Don't even think of using an linear supply in your Model III - Heat, Regulation and Reliability • Double density disk controller • Goldplated Edge Card Connectors • 32K Ram Expansion • All cables and necessary hardware • Installation Manual • Fully tested and burned in • 90 Day parts and labor warranty.

M3DK0 Drive Kit with one Tandon single-sided 40-track drive **\$595.00**

M3DK1 Drive Kit with two Tandon single-sided 40-track drives **\$799.95**

M3DK2 Drive Kit with two Tandon double-sided 40-track drives **\$1049.95**

M3DK4 Drive Kit with two Tandon double-sided 80-track drives **\$1249.95**

NEW! MDX-3 Interface Expansion Boards for your Model III from Micro-Design

Phone Modem • RS-232 Port • Floppy Disk Controller Dual Density Data Separator • Silk Screen • Solder Mask • User Manual

COMPLETE KIT **\$259.95**

- Printed Circuit Board **\$74.95**
- Disk Controller Kit **89.95**
- Serial Interface Kit **79.95**
- Modem Kit **29.95**

MDX-2 Interface Expansion Boards for your Model I from Micro-Design

COMPLETE KIT **\$269.00**

- MDX-2 printed circuit board **\$74.95**
- Onboard direct connect modem kit **39.95**
- 2K/4K Eprom kit **17.95**
- RS232 mA serial interface **17.95**
- Real-time clock kit **17.95**
- Floppy disk controller kit **31.95**
- 32K RAM expansion kit (less RAM) **11.95**
- Cassette port **3.95**
- Analog power supply **29.95**
- Hardware and socket kit **19.95**
- Centronic line printer port **8.95**

COMPUTEX Comprehensive Test Program **\$21.95**

• disk drive speed test • disk drive alignment program (requires alignment disk - Dysan Alignment Disk \$39.95) • expansion Interface RAM test • keyboard RAM test • video RAM test • keyboard bounce test • ROM checksum program • full screen RAM display program.

VISA, MASTERCARD, AMERICAN EXPRESS ACCEPTED • Net - 30 terms for D&B rated companies. All products will carry an additional 10 percent handling fee. Prices subject to change without notice. Prices do not include shipping.



a subsidiary of World Wide Data Systems, Inc.

(713) 488-8022

**321 El Dorado
Webster Texas 77598**

A new dot-matrix printer from Japan.

C. Itoh 8510

C. Itoh 8510 Pro/Writer Dot-Matrix Printer
C. Itoh Electronics
 New York, NY
 \$825

Mike Keller
 13423 Desert Hills NE
 Albuquerque, NM 87111

There seems to be no limit to Japanese ingenuity. This time they have created the Pro/Writer, a 9 by n dot-matrix printer with high-quality print for the serious user and a full repertoire of tricks for the hobbyist. It is made by TEC and marketed in this country by C. Itoh, a firm known for its daisy-wheel printers.

This printer is also being marketed as the ADS 8001 and, with a slightly different body style, as the NEC 8023A.

The magazine ads for the Pro/Writer looked awfully good. I called Antex Data Systems—a California dealer who handles the Pro/Writer. They patiently answered my questions and sent print samples. I also called the head office of C. Itoh for additional technical information.

A day after the print samples arrived, I received, from the head office, a pleasant surprise—a 56-page preliminary operation manual for the Pro/Writer at no charge. The manual confirmed all the advertised features—and then some. Satisfied, I placed an order and had the printer 13 days later.

Main Features

It accepts single sheets, roll paper, or fanfold, and can produce up to three carbons. Printing speed is 100 characters per second (unidirectional or bi-directional with logic seeking). A quick-cancel feature moves the print head faster when it is repositioned for the next line. Paper feeding can be forward or reverse. Line-feed spacing is variable from 1/144 to 99/144 inch, making superscript and subscript easy.

It has a dot-addressable graphics mode

for designing your own characters or making fancy drawings. The dots can be printed with a resolution of up to 160 dots per inch horizontally and 144 vertically. As an urban cowboy friend of mine says, "You can't hardly git more denser than that."

16 DIP switches allow you to set up a variety of default conditions, such as printing slashed or unslashed zeroes. Other standard goodies include: a typewriter-like proportional character set; a self-test function; and a 1,500-character buffer that allows the Pro/Writer to accept data while printing—not a bad grocery list for an inexpensive printer.

Physical Appearance

It is a good looking printer, with clean lines and an uncluttered appearance. The adjustable tractor sprockets are located behind the friction-feed platen and are completely hidden from view during normal operation. The platen and print mechanism are protected by a hinged transparent cover with a serrated tear bar for clean separation of roll paper and fanfold sheets. The tear bar eliminates diagonal rips in the paper.

Standard pushbuttons for line feed, form feed and select/deselect are located in a recessed portion of the front panel, as are three LED lights to indicate power-on, select and paper-empty conditions. The angle of this recess makes the controls easy to see from just about any position, without leaving them exposed to possible damage.

Construction and Economics

At nearly 19 pounds, the Pro/Writer is hefty compared to some other small printers. There is a lot of steel in the machine that accounts for the weight. It also gives a feeling of confidence in the durability of the machine. Most of the plastic is on the outside. Its internal parts are held together by screws, not glue. Although I am not a repair expert, it looks as though the 8510 should be easy to work on when repair is needed. The electronics are all on a single

board. The DIP switches are fairly easy to access even with paper threaded in the printer.

The print head is attached with two screws and can easily be replaced. An upcoming version of the 8510 will have a snap-in print head. The estimated life of the head is rated at 100 million characters. A replacement costs about \$75.

The Pro/Writer uses a cartridge-type ribbon which simply snaps in place and does not require any threading. A new cartridge sells for about \$12 and should be good for three million characters.

The parallel interface version of the printer lists for \$825, but discounted prices of less than \$600 can be found. This substantial savings, for me, justified the mail-order purchase of a printer without a large network of maintenance facilities. Considering its stout construction a breakdown should be rare. C. Itoh extends a 90-day warranty to its dealers, but prospective buyers should check with their dealer about specific warranty terms.

8510 and the TRS-80

The printer can be ordered with Centronics parallel, RS-232-C serial or Apple computer interfacing. A TRS-80 connecting cable is not included, but the 8510 with parallel interface works fine on my Model I using a standard Radio Shack printer cable, catalogue No. 26-1401. Curiously, when I first turned on the computer with the printer turned off, the DOS would not work. My TRS-80's Expansion Interface is one of the earlier versions and for some reason the printer must be turned on before booting the rest of the system. Connecting the Pro/Writer to a friend's TRS-80 (with the later version Expansion Interface) showed no such peculiarity. Now I simply turn the printer on first and everything hums along normally.

The Pro/Writer's graphic characters are not the same as the block graphics generated on the TRS-80 screen. Those characters can, however, be built using the printer's

How to maximize your Model III:

You don't have to settle for standard equipment. Let MTI and Alpha Byte help you build the Model III you want.

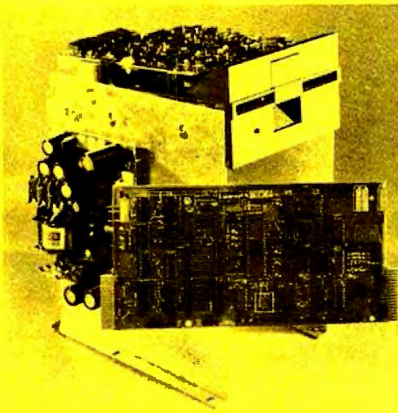

MTI FLOPPY DISK ADD-ON KITS

Now you can upgrade your 16K level II Model III to a full 48K Disk System the easy way with MTI's Double Density Disk Controller and your choice of Disk Drives. You can choose 40 track, Double-Sided 40 track or Double-Sided 80 track Drives to supply your disk storage needs. Forty Track Drives store 175K, Double-sided 40 Track drives store 350K. Four Double-Sided 80 Track Drives provide up to 3 MEGABYTES of On-Line storage.

INTERNAL DISK DRIVE KITS

The first drive kit includes one Tandem Disk Drive, MTI Double Density Controller, Switching power supply, 32K of RAM, all mounting hardware, cables and Detailed Installation Instructions. The second internal drive kit includes a second drive and the necessary installation hardware.

40 TRACK DRIVE SYSTEM	
DRIVE NO. 1 KIT	649.00
DRIVE NO. 2 KIT	259.00
40 TRACK DUAL HEAD SYSTEM	
DRIVE NO. 1	729.00
DRIVE NO. 2	369.00
80 TRACK DUAL HEAD SYSTEM	
DRIVE NO. 1	899.00
DRIVE NO. 2	549.00

EXTERNAL DRIVE KITS

Two external drives can be attached to any dual drive Model III Computer.

40 TRACK EXTERNAL DRIVES	
DRIVE NO. 3	359.00
DRIVE NO. 4	339.00
DUAL HEAD 40 TRACK EXTERNAL DRIVES	
DRIVE NO. 3	479.00
DRIVE NO. 4	459.00
DUAL HEAD 80 TRACK EXTERNAL DRIVES	
DRIVE NO. 3	659.00
DRIVE NO. 4	639.00

FIVE MEGABYTE EXTERNAL WINCHESTER HARD DRIVE..... 2795.00

Add the Ultimate in Fast High Capacity Disk Storage to any Model III Floppy Disk system. Reliable Winchester technology provides enough storage for the largest business files. Winchester disk drives have greatly increased data transfer rates and that means faster program and file loading. This is a complete self contained system that connects to a standard Model III Disk System in minutes without any modification to the computer.

MODEL III DIAGNOSTIC PROGRAM..... 49.95

A complete diagnostic program for the Model III. Tests RAM and ROM, video display and all disk drives. Catch problems while they're small and be sure that your Model III is in perfect running condition.

MODEL III CP/M-80 NOW AVAILABLE!... 799.00 CP/M® & 80. Column Kit.

Now you can run proven CP/M based software on your Model III, with standard 80-column display. A simple internal modification will transform your Model III into a NEW computer and allow you to run CP/M the industry-standard operating system and assure you of a large supply of fine software. Includes CP/M 2.2.

MODEL III SPEED-UP MOD..... 149.00

Now you can run your Model III at 4 MEGAHERTZ, that's almost double the standard speed. This simple-to-install kit does require some soldering.

MODEL III COOLING KIT..... 44.95

Heat build up is a major cause of system failures and 'flakey' operation. This kit provides excellent cooling.

DOSPLUS OPERATING SYSTEMS FOR THE MODEL III

Solid BUG-FREE operating systems for the Model III. Supports different size drives on the same system and Basic Program Chaining with variables saved in memory.

40 TRACK	99.00
80 TRACK	119.00
EXPANDED DOSPLUS 3.3.8	149.00
Read and Write 40 Track Diskettes on an 80 Track System	
HARD DISK DOSPLUS	299.00
Supports the MTI 5 MEG HARO DISK	

Alpha Byte

COMPUTER PRODUCTS

We guarantee everything for 30 days. If anything is wrong, return the item and we'll make it right. And, of course, we'll pay the shipping charges.

We accept Visa and Master Card on all orders; COD orders, up to \$300.00.

Add \$2.00 for standard UPS shipping and handling on orders under 50 lbs, delivered in continental U.S. Call for shipping charges over 50 lbs. Foreign, FPO and APO orders add 15% for shipping. Californians add 6% sales tax.

Prices quoted are for stock on hand and are subject to change without notice.

31245 LA BAYA DR, WESTLAKE VILLAGE, CALIFORNIA 91362

To order, or for information, call:
(213) 706-0333

To use our 24-hour modem order line, call: (213) 883-8976.

TRS-80* Computer Owners...

GREATER VALUES

New Low Prices for Percom Model III Disk Drives!

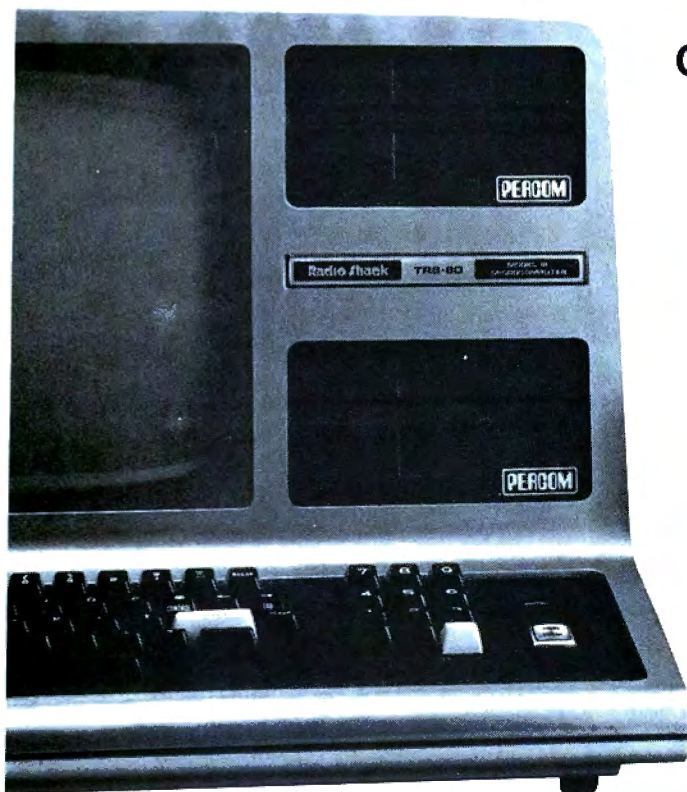

Complete First-Drive Systems from **\$449**

Internally mounted drives that feature double- or single-density storage, comprehensive pre-delivery testing, 48-hour burn-in and, best of all, Percom's widely acclaimed disk controller. A First-Drive System includes the four-drive disk controller, one or two drives, power supplies, cables and a fully illustrated owners manual. Use Model III TRSDOS*, Percom OS-80+ and all other Model III compatible DOSs.

Note: If you prefer not to make the First-Drive System installation, we'll do it for only \$29.95 plus shipping. This includes a 48-hour operating burn-in of your Model III computer, installation of the drive system and final checkout of the expanded system.

Our Own Fully Tested Drives from only **\$275**

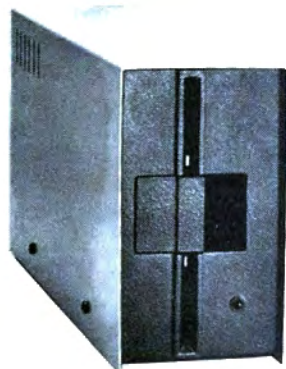

- Every Access Floppy Disk drive is electrically tested, mechanically tested and burned-in 48 hours under operating conditions. Look for the signed test list in the shipping carton.
- AFD drives are capable of either single- or double-density operation. Store up to 364 Kbytes (formatted) in double density. Store twice the data on a single diskette using AFD "floppy" drives."
- 15-day free trial offer...comprehensive 90-day limited warranty...unbeatable prices...AFD-100 @ \$275.00, -100F @ \$329.00, -200 @ \$429.95, -200F @ \$449.95.

How to order - Order by calling Access Unlimited toll-free on 1-800-527-3475. Or order by mail. Orders may be charged to a VISA or Master Card account, or paid by cashier's check, certified check or money order. COD orders require 25% deposit. Sorry, we cannot accept personal checks. We pay freight (surface only) and insurance charges for shipments in U.S. on orders over \$1,000.00. Add approximate insurance and shipping charges for orders under \$1,000.00. If in doubt about these charges, ask when you call in your order. Texas residents include 5% sales tax. Minimum mail order \$20.00. Allow 2 to 4 weeks for delivery.

Technical & Texas: (214) 340-5366

Save! VISA and Master Card charges are not deposited until the day your order is shipped.

Everybody's Favorites - for Less!

Percom Data Separator	\$23.95
Green Screen I, II, or III	\$18.95
Head Cleaning Kit	\$24.95
Drive Numbering Tabs (pkg 0-3)	\$3.00
5 1/4" Flip-N-File	\$24.95
8" Flip-N-File	\$39.95

PRICES AND SPECIFICATIONS SUBJECT TO CHANGE WITHOUT NOTICE.

— LOWER PRICES

Percom's Proven DOUBLER II† Upgrade Your Model I to Double Density for only \$159.95

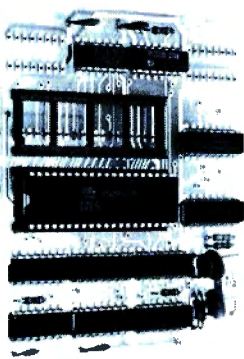

And not with some unproven hacker's kit, either. But with an assembled and fully tested *Percom DOUBLER-II†*. The DOUBLER-II† simply plugs into the disk drive controller socket of your Expansion Interface. Then it lets you store over four times more on one side of a diskette, depending on the drive, than you can store on standard Tandy Model I drives. Other features: • Reads, writes and formats *either* single- or double-density • Includes DBLDOS™, a TRSDOS* compatible disk-operating system • Runs TRSDOS*, NEWDOS††, Percom OS-80† and other single-density software immediately. Change to double-density operation when convenient • Lets Model III software be read on your Model I • Includes on-card high-performance data separation and write precompensation circuitry.

Incredibly Low Prices for Epson and Okidata Printers!

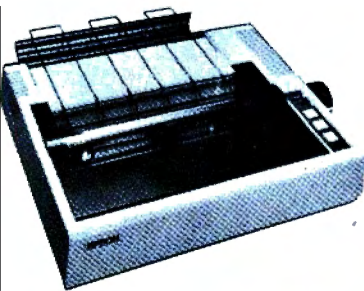

The two most popular printers on the market today. They provide the features you want, the reliability you need, a price you can afford.

MX-80 – Call for latest low price.

Microline 80 only \$399.95

Other models available.



Low Cost System Furniture

Modular design permits custom arrangements • Furniture styling and quality • TRS-80* colors • OK for UPS shipping • Reassemble without tools

System desks from \$115
Printer stands from \$144

Arrick Products Quick-Switch‡

Just flick a switch to connect your TRS-80* printer port from device #1 to device #2. Or, "Quick-Switch" a peripheral between computers. Versions for RS-232 or Centronics interfacing. Includes 5-foot 34-pin cable with card-edge socket, box-mounted 34-pin card-edge plugs. From \$79.95.

‡ trademark of Arrick Products Company.

Save! Make ACCESS your one-call shopping center for TRS-80* hardware and software. Call our toll-free order number for free product literature and latest prices.

**Toll-Free
Order No.**

1-800-527-3475 ◊

(orders & literature only)

ACCESS UNLIMITED

401 N. Central Expressway #600
Richardson, Texas 75080
(214) 340-5366

*Trademark of Access Unlimited
†Trademark of Percom Data Company, Inc.

26

‡Trademark of Tandy Radio Shack Corporation.
◊Trademark of Apparel Corporation.

The Cornsoft Group PRESENTS:
New! SPACE CASTLE
 FOR TRS-80 MODELS I & III

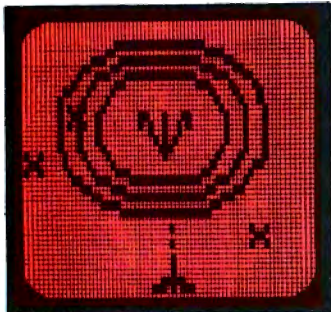

Will you save the Andromeda Galaxy by destroying the Space Castle or will the evil warlord Yugdab continue to rule, uncontested? Locked in battle with Yugdab, your main defense is your ability to skillfully handle your ship and it's projectiles. If you are not careful, Yugdab's intelligent mines will hunt you down and blow you into space dust. Written in machine language, Cornsoft's New Arcade Game, Space Castle, has fast action and exciting sound. Yes, Joystick owner's, the Alpha Joystick really puts you in the cockpit!!

16K Model I & III Tape: 15.95 + 1.50 Shipping
32K Model I & III Disk: 19.95 + 1.50 Shipping

Indiana Residents Add 4% Sales Tax

New! SCARFMAN
 FOR THE TRS-80 COLOR COMPUTER

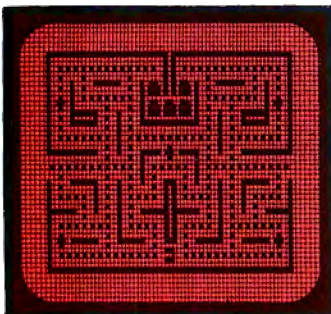

It's eat or be eaten. That's right!!! Now color computer owners can enjoy the same thrills that lots of Model I & III owners are raving about, like Mrs. David Cullen, Germantown, Maryland, who writes:

"My highest (score) to date is 271,090. I have achieved this on our TRS-80 Model III, without Joysticks. I honestly don't play all day — my three children wouldn't allow it — but I think it's great fun!!

Congratulations on the Third Highest Score to date: (Highest: 289,565 by David Leventhal)

Written in machine language, Scarfman has the Excitement, Graphics, Sound and Real Time Action that have become a trademark of the Cornsoft Group. Scarfman is also Alpha Joystick compatible.

TRS-80 Color Computer Tape: 19.95 + 1.50 Shipping
16K Model I & III Tape: 15.95 + 1.50 Shipping
32K Model I & III Disk: 19.95 + 1.50 Shipping

Indiana Residents Add 4% Sales Tax

The Cornsoft Group

6008 N. KEYSTONE AVE.
 INDIANAPOLIS, IN 46220
 (317) 257-3227

✓308

MASTER CARD & VISA ORDERS ACCEPTED

CANADIAN OWNERS — Contact:
 RAINBOW SOFTWARE DISTRIBUTORS
 7070B Farrel Road SE, Calgary, Alberta T2H 0T2, (403)-253-6142
 TRS 80® is a registered trade mark of the Tandy Corp.

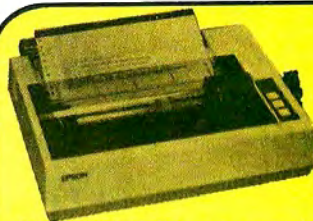

MX-80 OWNERS

MXPLUS™ ADDS NEW CONVENIENCE

- PERF-SKIP TO AUTOMATICALLY GIVE YOU TOP AND BOTTOM MARGIN ON EACH PAGE. (SWITCH SELECTABLE, OF COURSE)
- MANUAL PRINT MODE CONTROL TO LET YOU SELECT CONDENSED, EMPHASIZED, OR NORMAL PRINTING INSTANTLY USING THE PRINTER PANEL BUTTONS.

MXPLUS™ INSTALLS IN MINUTES, NO SOLDERING!

MXPLUS IS A PLUG-IN MODULE FOR STANDARD MX-80 AND MX-80 F/T. MODELS AVAILABLE SOON FOR MX-100 AND GRAFTRAX. PLEASE CALL. MXPLUS IS UNCONDITIONALLY GUARANTEED FOR 30 DAYS.

MX-80, MX-80 F/T, AND GRAFTRAX ARE TRADEMARKS OF EPSON

ORDER TODAY

ORDERS CALL 24 HR 800-835-2246x441
 INFORMATION CALL 213-969-2250

ONLY
\$49.95

POSTPAID CALIF ADD 6%

DRESSELHAUS COMPUTER PRODUCTS
 22713 VENTURA BLVD. SUITE F
 WOODLAND HILLS, CA 91364

SAME DAY SHIPPING
 WITH MC VISA



✓353

Tired OF THE LINE-EDIT Game?

Then why not try our Full-Screen Editor?

NOW - Create & Edit BASIC programs quickly and easily with this versatile Full Screen Basic Editor.

FEATURING Eleven commands and thirteen control keys to do any edit function you may require.

- Scroll Forward & BACKWARD through program
- Change many lines at one time
- Insert or delete characters
- Add or delete lines
- Search for strings
- Load the Editor once—it becomes an extension of your Model 3 BASIC
- Call the Editor with one command
- Return to BASIC by pressing BREAK

INSTRUCTION MANUAL ONLY (refundable)

\$1.00

Model III Level II Tape..... \$19.95

NJ residents add \$1.00 Sales Tax

des SOFTWARE

86 Mansel Dr. Landing, N.J., 07850

✓517

"My first week with the Pro/Writer was rough."

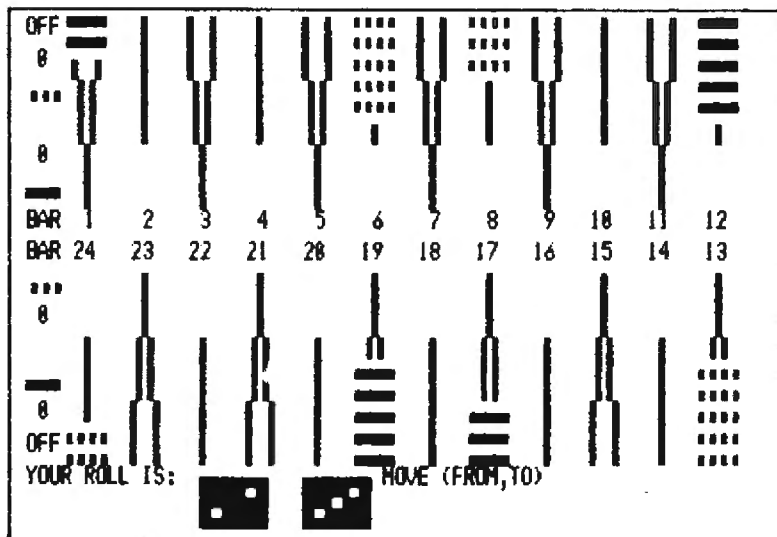

Fig. 2. Sample Screen Printer with Constructed TRS-80 Graphics.

a TRS-80 and the dot graphics capability of the Pro/Writer.

Using the 8510

My first week with the Pro/Writer was rough. This was due to erroneous or missing decimal values in the operator's manual for some of the ASCII control codes. Other than this and some phrases poorly translated from Japanese, the documentation is pretty good. After figuring out the right values, I had no trouble using all the printer's functions, but that first week would have gone more smoothly if an errata sheet had been included in the manual.

Most of the control codes are straightforward, although some require a numeric value be sent in its ASCII form. For example, to set the left margin to 5, you send the control code ESC "L" (ESC is decimal 27) followed by three ASCII characters 0, 0, and 5, rather than a decimal value of 5. This can be done from Basic with `LPRINT CHR$(27); "L005"`. It was a little strange at first, but now that I am used to it, I like it.

At times, I need to watch the printing process as it takes place. This is easy on the Pro/Writer because the print line is less than one inch below the paper cutoff. I do not have to stand over the machine and peer inside to see what is going on.

Fanfold and roll paper are threaded into the rear of the printer and exit through the top. A separator is not needed. I have not had a case of incoming paper fouling with outgoing paper, even though I sometimes use the back side of discarded fanfold. Single sheets are fed through a separate opening in the top of the printer.

dot-addressable graphics. I wrote a machine-language routine to reproduce the TRS-80's screen contents, including its graphics, on the 8510. Fig. 2 shows the resulting screen dump made during a backgammon game. The screen-print program draws a thin border around the printed image to represent the edges of the screen. I included this to provide a subtle visual reference present on the monitor but missing from most screen-prints.

Fig. 3 is an example of what happens when you mix Bob Boothe's programming genius (*80 Microcomputing*, April 1981) with

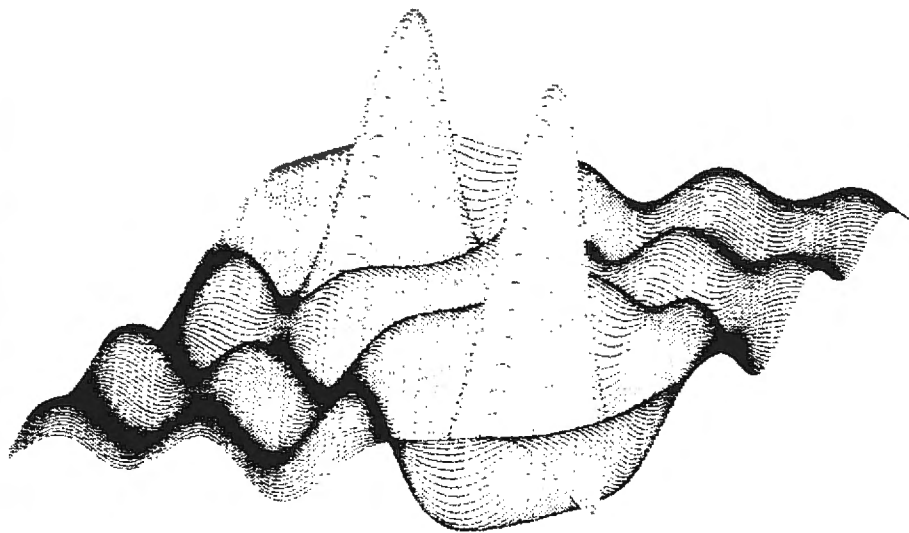

Fig. 3. High-Resolution Graphics.

The Lawyer's Microcomputer™

A Newsletter for Lawyers Using the TRS-80*

- Articles for Lawyers
- Law Office Applications
- Lawyer Information Exchange
- Software Reviews
- Hardware Reviews
- Advertisements Directed to Lawyer Users
- Technical Tips
- Letters and Suggestions
- And Much More

A New Monthly Newsletter For Lawyers

Send \$28 For A One Year Subscription

The Lawyer's Microcomputer™
 Post Office Box 1046A
 Lexington, S.C. 29072

191 *TM Tandy Corp



WAYNE GREEN INC.

PETERBOROUGH, NEW HAMPSHIRE 03458 USA

Winter/Spring 1982

Dear *80 Microcomputing* Subscriber:

We are making a cover date change on *80 Microcomputing*. What would have been your June 1982 issue will be the June/July 1982 issue. We are not combining an issue—simply changing the month listed on the cover. You will still get 12 issues of *80 Microcomputing* in 1982 and 12 issues in 1983, and so on; and we will change your expiration date by adding a month (more on that later) so you don't end up short-changed.

The reason for the cover date change? There has been an increasing demand for *80 Microcomputing* to be sold on major newsstands. Because *80 Microcomputing* is the last publication to be produced each month by the Wayne Green group it has not been getting to the newsstands on time. A complicated production change could have been made, but a simple cover date change will produce the same results—a full month's sale on the newsstand. Thus, the cover date change.

The change has other benefits. . . you, the subscriber, will be getting your magazines well before the local computer stores and newsstands. I've been hearing complaints that they get it first; after the June/July issue they won't (although they will still receive it in the month prior to cover date). Also, advertisers' ads will be assured of the full month on the newsstands, in computer stores and in your hands.

As I have said, you will still get 12 issues this year. *80 Microcomputing* will be in your mailbox every month, but the one you receive in June will say June/July, the one you receive in July will say August, and so on. We will, however, have to change your expiration dates to make up for the missing "cover month" and our computer will do that all at once. Note the upper right hand corner of your address label now and then note it after the date change and you will see a month's difference in the date listed there. If such a change does not occur please write to me at 80 Pine Street, Peterborough, NH 03458, and I will personally see that it is changed.

Thank you for your support of *80 Microcomputing*. I hope you continue to enjoy your subscription.

Sincerely,

Debra L. Boudrieau
Director of Marketing

73 MAGAZINE
KILOBAUD MICROCOMPUTING
80 MICROCOMPUTING
DESKTOP COMPUTING
MICROCOMPUTING INDUSTRY
INSTANT SOFTWARE
LOAD 80
WAYNE GREEN BOOKS
WAYNE GREEN INTERNATIONAL

*"I would not trade
my Pro/Writer for any of the
other printers on the market. . ."*

One problem normally encountered in single-sheet printing is the printer may think it is out of paper when there are still five or six unprinted lines at the bottom of a page. The Pro/Writer allows the operator to override this false paper-empty signal by repeatedly pressing the select switch. This makes it possible to print to the bottom of a single sheet—a nice touch.

Sophisticated forms control is possible on this printer. You can define page length, top and bottom margins, left margin and up to 16 horizontal tabs. The 8510 can also be programmed to remember five separate page formats, each page with its own vertical tab settings. For example, page three might be assigned tabs at the sixth and twenty-third lines, while page five has tabs set at lines 10, 20 and 30. This is a nice feature for cranking out data on pre-printed forms, though it does require planning and skill in converting binary numbers to decimal.

During printing, the 8510 is relatively quiet for an impact printer. It is a little quieter than a standard (tractor feed) MX-80, and is considerably more quiet than my Radio Shack line printer. Stepper motors are used for platen and carriage movement, so the printer is completely silent when idle.

Character Possibilities

The 8510 has essentially two styles of print: standard and proportional. Both

styles contain the full ASCII set with the lowercase and descenders, as well as an assortment of graphics, Greek letters, and some useful symbols. A set of Japanese characters is also included.

Standard (uniformly spaced) letters can be printed in six sizes ranging from 40 to 136 characters per line, and proportional letters (actually a separate set of very nicely shaped characters) can be printed in two sizes. Both print styles can be enhanced with bold printing and automatic underlining. The underlining is solid, rather than a series of broken lines, and does not require any backspacing or special housekeeping, since the underline is printed along with the character. Considering all the possible style, size and enhancement combinations, there are 32 different ways to represent a given character (see Fig. 1). You can change from one combination to another in the middle of a line. This printer does not arbitrarily cancel a selected mode at the end of the line.

A Few Complaints

No one printer can be everything to everybody. The 8510 has some weaknesses in my particular application. I find the VFU cumbersome to program and usually do not even bother with it, except for channel 1 now and then. If you run programs that need fancy vertical forms control, you will no doubt find the VFU a blessing, but given my druthers I would prefer a less sophisticated,

easier method of setting vertical tabs.

I have both hot and cold feelings about the 1.5K buffer. At times, it is great to have control returned to my computer almost immediately after executing a long LPRINT list, instead of having to sit and wait for the printer to finish. It can be a curse, though, since there is no way of purging the buffer if you change your mind after the printing is underway, except by turning the printer off and back on again. It would be nice to have a button to clear the buffer without cancelling other activated functions.

Another thing I wish for is easier threading of single sheets. For some reason, we dot-matrix printer users still have to move several machine parts out of the way merely to insert one sheet of paper. After some practice, you become adept at it, but this is something the user should not have to learn.

And finally (my sincere apologies to the Japanese), I keep thinking about all that precious character-generator ROM being used up by a set of figures I will probably never print. Perhaps someone will come up with a modified ROM for machines sold in America.

To bring these gripes into perspective, they are small when viewed in the light of this printer's overall performance. Objections notwithstanding, I would not trade my Pro/Writer for any of the other printers on the market within several hundred dollars of its price. ■

DISCOUNT COMPUTERS

**100% RS Components • No Foreign Drives or Memory
FULL WARRANTY**

16K MOD III	\$ 815	LINE PRINTER VI	\$ 975
48K MOD III 2 Dr. RS232	\$1998	LINE PRINTER VII	\$ 299
64K MOD II 1 Dr	\$3120	LINE PRINTER VIII	\$ 599
128K MOD 16 2 Dr	\$4930	DAISY WHEEL II	\$1599
VERBATIM 5¼ Datalife	\$ 210 per 100	MEMOREX 8" Dbl. Density	\$ 270 per 100
VERBATIM 5¼ Plastic Box	\$ 220 per 100	ALL RS SOFTWARE	20% Off

ALL OTHER ITEMS CARRY SIMILAR PRICING. CALL FOR PRICES.

Cashiers Check or Money Order must accompany all orders.

Shipped Freight Collect

(214) 271-2955

NOCONA ELECTRONICS

DLR#F-731

BOX 2063

GARLAND, TX 75041

✓ 232

The Original Magazine for Owners of the TRS-80™ MicroComputer

MODEL I • MODEL II • MODEL III • POCKET COMPUTER • COLOR COMPUTER

Software
for TRS-80
Owners

COMPUTRONICS INC.

Monthly
Newsmagazine
for TRS-80
Owners

MONTHLY NEWS MAGAZINE



- PRACTICAL APPLICATIONS
- NEW EXPANDED BUSINESS SECTIONS
- GAMBLING
- GAMES
- EDUCATION
- PERSONAL FINANCE
- BEGINNER'S CORNER
- NEW PRODUCTS
- SOFTWARE EXCHANGE
- MARKET PLACE
- QUESTIONS & ANSWERS
- PROGRAM PRINT OUTS
- ...and MORE!

YOUR CHOICE
FREE

with your Subscription or Renewal



A.

NANOS SYSTEMS CORP.

TRS-80 At Your Fingertips

Complete quick reference guide to basic, assembly language* and graphic codes — all at your fingertips for all TRS-80 computers (specify computer).

Assembly Language Section N/A for Color Computer

B.

A Word Processor, Data Management System and Cleanup

(A maze game) All on cassette. (Add \$3 for diskette, add \$5 for modified MOD-II diskette version —N/A on color computer or pocket computer.)

OR

COMPUTRONICS!

50 North Pascaack Road
Spring Valley, New York 10977

- One Year Magazine Subscription \$24 New Renewal
 Two Year Magazine Subscription \$48.00 New Renewal
 Sample Issue \$4. Mod II Newsletter Subscription \$18
 Your Choice: TRS-80™ at Your Fingertips () or Word Processor/ Data Management ()
 Model I Model II Model III Color Computer Pocket Computer

CALL TOLL FREE
800-431-2818

(Outside of New York State)

24 HOUR ORDER LINE
914-425-1535



NEW! **MOD-II NEWSLETTER**
NEW! 18/Year (or 12 issues)

Name _____ Address _____ City _____

State _____ Zip _____ Signature _____

Credit Card Number _____ Expiration Date _____

Add \$12/Year (Canada, Mexico) — Add \$24/Year Air Mail outside of U.S.A., Canada, and Mexico
All Prices and Specifications Subject to Change

* TRS-80 is a trademark of the Radio Shack Division of Tandy Corp

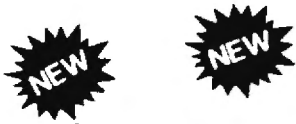

from **HOWE SOFTWARE**
FOR THE TRS-80 MODEL I AND MODEL III

System Diagnostic

Tests Every Component Of Your TRS-80 and Verifies Proper Operations

For Cassette or Disk

DISK

\$99.95

CASSETTE

\$94.95

IS YOUR COMPUTER WORKING?

ARE YOU SURE?

- ROM: checksum test
- RAM: four separate tests including every address and data value.
- VIDEO DISPLAY: character generator, video RAM, and video signal.
- KEYBOARD: every key contact tested.
- LINE PRINTER: character test.
- CASSETTE RECORDER: read/write/verify data.
- RS-232-C INTERFACE: connector fault, data transmission, framing, data loop, baud rate generator.
- DISK DRIVES: disk controller, drive select and restore, track seek and verify data, read/write/verify all tracks and sectors with or without erasing, sector formatting, disk drive timer, disk head cleaner.

- Individual tests of each device with operator monitoring and intervention.
- Continuous system tests run continually for hours testing each component, with diagnostic reports optionally written on line printer.
- One program adapts to any system configuration and hardware.
- Complete instructions and documentation.

SMART TERMINAL

Enables your TRS-80 to be used as a data communications terminal to a time-sharing system, computer bulletin board, or another computer, via the RS-232-C interface.

- MEMORY BUFFER holds data for transmission or data received from other computer.
- CASSETTE or DISK may be used to load or save data from memory.
- AUTOMATIC TRANSMISSION of data from memory.
- AUTOMATIC STORAGE of incoming data at user's option.
- TRANSMIT or RECEIVE WITH VERIFICATION options included for communication between two TRS-80s using Smart Terminal.
- Full CONTROL KEYS, including control key mapping into any ASCII character. True BREAK key. Lower case supported on Model I.
- Buffered LINE PRINTER ECHO for incoming data.
- Disk and cassette files fully compatible with ELECTRIC PENCIL™ and SCRIPSIT™ programs.
- BAUD RATE and RS-232-C CHARACTERISTICS can be reset from within the program.
- SAVE PROGRAM option creates "personalized" back-up copy of program with all options set as specified by user.
- ONE PROGRAM supports both cassette and disk systems. Program is compatible with PMC-80 and other TRS-80 "work alike" computers.

Model I or III Version **supplied on cassette \$69.75**
supplied on diskette \$74.95
 Model II (CP/M) Version **\$79.95**

MON-3 and MON-4

The TRS-80 Monitor Programs #3 and #4 are powerful utility programs enabling you to interact directly with the TRS-80 in Machine Language. They are as useful for beginners as for advanced programmers.

- BEGINNERS can learn to interact directly with the computer in Machine Language.
- 40-PAGE MANUAL provided with each program.
- SIMPLE commands, easy to use.

The Features Of The Monitor Programs Enable You To The Following.....

- DISPLAY memory in different ways.
- DISASSEMBLE memory to see Machine Language commands.
- MOVE and COMPARE memory areas.
- SEARCH through memory to find specific values.
- MODIFY memory in various ways.
- RELOCATE object programs.
- PRINT output on video display or line printer.
- READ and WRITE object tapes in SYSTEM Format.
- UNLOAD programs using low RAM on disk.
- SAVE and READ disk files (MON-4 Only).
- INPUT and OUTPUT of disk sectors (MON-4 Only).
- SEND and RECEIVE data over RS-232-C Interface (MON-4 Only).
- Create SYMBOLIC Tapes (MON-3) or Files (MON-4) of Disassembled output for Editor/Assembler program.

MON-3 (For Cassette Systems) **\$39.95**
 MON-4 (For Disk Systems) **\$49.95**

MAILING LIST

Maintains mailing lists of over 1000 names. Commands allow adding, changing, deleting, and finding names. Sorting is done by machine language according to the information in any field (i.e., name, address, zip code). Labels printed in 1, 2, or 3 columns, in master list on one line, or on video display.

Disk Version Only \$69.95

HOME BUDGET

Combines the maintenance of your checkbook with analysis of your income, expenses, and monthly bills. Handles data including bills, including bills, income, deposits, checks and debits to your checking account, and cash expenses. Computes checkbook balance, list of unpaid bills, monthly and year-to-date summaries of income and expenses showing income tax deductions. All output printed on video display or line printer at user's option. Complete instructions for customizing to suit your own budget.

Cassette \$29.95
Disk \$49.95

SMALL BUSINESS ACCOUNTING

Based on Dome Bookkeeping Record #612, this program keeps track of income, expenditures, and payroll for a small business of up to 16 employees. Income and expenditures can be entered on a daily, weekly, or monthly basis, and the program computes monthly, through last month, and year-to-date summaries. Payroll section keeps record of individual employees and their paychecks with up to six categories of payroll deduction. Employee payroll record and year-to-date payroll totals can be computed. Manual contains complete instructions for customizing to suit your business.

Disk Version \$49.95
Cassette Version \$29.95
 (Cassette Version does not contain payroll)

COMPUTRONICS

50 N. PASCACK ROAD
 SPRING VALLEY, NEW YORK 10977



24 HOUR ORDER LINE

(914) 425-1535

NEW TOLL-FREE ORDER LINE

(OUTSIDE OF N.Y. STATE)

(800) 431-2818

- All orders processed within 24 Hours
- 30-Day money back guarantee
- Add \$3.00 for shipping in UPS Areas
- Add \$4.00 for C.O.D. or NON-UPS Areas
- Add \$5.00 to Canada or Mexico
- Add exact postage to all other countries

H & E COMPUTRONICS INC.

•• EVERYTHING FOR YOUR TRS-80™ • ATARI™ • APPLE™ • PET™ • CP/M™ • XEROX™ • IBM™ ••

* TRS-80 is a trademark of the Radio Shack Division of Tandy Corp. • ATARI is a trademark of Atari Inc. • APPLE is a trademark of Apple Corp. • PET is a trademark of Commodore
• CP/M is a trademark of Digital Research • XEROX is a trademark of Xerox Corp. • IBM is a trademark of IBM Corp.



BUSINESS PAC 100

100 Ready-To-Run Business Programs

★ All orders processed within 24-Hours
★ 30-Day money back guarantee on all Software

(ON CASSETTE OR DISKETTE).....Includes 128 Page Users Manual.....
Inventory Control.....Payroll.....Bookkeeping System.....Stock Calculations.....
Checkbook Maintenance.....Accounts Receivable.....Accounts Payable.....

BUSINESS 100 PROGRAM LIST

NAME	DESCRIPTION
1 RULE7B	Interest Apportionment by Rule of the 78's
2 ANNU1	Annuity computation program
3 DATE	Time between dates
4 DAYYEAR	Day of year a particular date falls on
5 LEASEINT	Interest rate on lease
6 BREAKVEN	Breakeven analysis
7 DEPRSL	Straightline depreciation
8 DEPRSY	Sum of the digits depreciation
9 DEPRDB	Declining balance depreciation
10 DEPRDDB	Double declining balance depreciation
11 TAXDEP	Cash flow vs. depreciation tables
12 CHECK2	Prints NEBS checks along with daily register
13 CHECKBK1	Checkbook maintenance program
14 MORTGAGE/A	Mortgage amortization table
15 MULTMON	Computes time needed for money to double, triple, etc.
16 SALVAGE	Determines salvage value of an investment
17 RRVARIN	Rate of return on investment with variable inflows
18 RRCONST	Rate of return on investment with constant inflows
19 EFFECT	Effective interest rate of a loan
20 FVAL	Future value of an investment (compound interest)
21 PVAL	Present value of a future amount
22 LOANPAY	Amount of payment on a loan
23 REGWITH	Equal withdrawals from investment to leave 0 over
24 SIMPDISK	Simple discount analysis
25 DATEVAL	Equivalent & nonequivalent dated values for oblig.
26 ANNUDEF	Present value of deferred annuities
27 MARKUP	% Markup analysis for items
28 SINKFUND	Sinking fund amortization program
29 BONDVAL	Value of a bond
30 DEplete	Depletion analysis
31 BLACKSH	Black Scholes options analysis
32 STOCVAL1	Expected return on stock via discounts dividends
33 WARVAL	Value of a warrant
34 BONDVAL2	Value of a bond
35 EPSEST	Estimate of future earnings per share for company
36 BETAALPH	Computes alpha and beta variables for stock
37 SHARPE1	Portfolio selection model-i.e. what stocks to hold
38 OPTWRITE	Option writing computations
39 RTVAL	Value of a right
40 EXPVAL	Expected value analysis
41 BAYES	Bayesian decisions
42 VALPRINF	Value of perfect information
43 VALADINF	Value of additional information
44 UTILTY	Derives utility function
45 SIMPLEX	Linear programming solution by simplex method
46 TRANS	Transportation method for linear programming
47 EOQ	Economic order quantity inventory model
48 QUEUE1	Single server queueing (waiting line) model
49 CVP	Cost-volume-profit analysis
50 CONDPROF	Conditional profit tables
51 OPTLOSS	Opportunity loss tables
52 FQIQOQ	Fixed quantity economic order quantity model
53 FQEQWSH	As above but with shortages permitted
54 FQEQQPB	As above but with quantity price breaks
55 QJUECB	Cost-benefit waiting line analysis
56 NCFANAL	Net cashflow analysis for simple investment
57 PROFIND	Profitability index of a project
58 CAP1	Cap. Asset Pr. Model analysis of project

59 WACC	Weighted average cost of capital
60 COMPBAL	True rate on loan with compensating bal. required
61 DISCBAL	True rate on discounted loan
62 MERGNAL	Merger analysis computations
63 FINRAT	Financial ratios for a firm
64 NPV	Net present value of project
65 PRINDLAS	Laspeyres price index
66 PRINDPA	Paasche price index
67 SEASIND	Constructs seasonal quantity indices for company
68 TIMETR	Time series analysis linear trend
69 TIMEMOV	Time series analysis moving average trend
70 FUJPRINF	Future price estimation with inflation
71 MAILPAC	Mailing list system
72 LETWRT	Letter writing system-links with MAILPAC
73 SORT3	Sorts list of names
74 LABEL1	Shipping label maker
75 LABEL2	Name label maker
76 BUSBUD	DOME business bookkeeping system
77 TIMECLCK	Computes weeks total hours from timeclock info.
78 ACCTPAY	In memory accounts payable system-storage permitted
79 INVOICE	Generate invoice on screen and print on printer
80 INVENT2	In memory inventory control system
81 TELDIR	Computerized telephone directory
82 TIMUSAN	Time use analysis
83 ASSIGN	Use of assignment algorithm for optimal job assign.
84 ACCTREC	In memory accounts receivable system-storage ok
85 TERMPAY	Compares 3 methods of repayment of loans
86 PAYNET	Computes gross pay required for given net
87 SELLP	Computes selling price for given after tax amount
88 ARBCOMP	Arbitrage computations
89 DEPRSF	Sinking fund depreciation
90 UPSZONE	Finds UPS zones from zip code
91 ENVELOPE	Types envelope including return address
92 AUTOEXP	Automobile expense analysis
93 INSFILE	Insurance policy file
94 PAYROLL2	In memory payroll system
95 DILANAL	Dilution analysis
96 LOANAFFD	Loan amount a borrower can afford
97 RENTPRCH	Purchase price for rental property
98 SALELEAS	Sale-leaseback analysis
99 RRCONVBD	Investor's rate of return on convertible bond
100 PORTVAL9	Stock market portfolio storage-valuation program

- CASSETTE VERSION \$99.95
- DISKETTE VERSION \$99.95
- TRS-80* MODEL II VERSION \$149.95

ADD \$3.00 FOR SHIPPING IN UPS AREAS
ADD \$4.00 FOR C.O.D. OR NON-UPS AREAS
ADD \$5.00 TO CANADA AND MEXICO
ADD PROPER POSTAGE OUTSIDE OF U.S.,
CANADA AND MEXICO

COMPUTRONICS
MATHEMATICAL APPLICATIONS SERVICE

50 N. PASCACK ROAD
SPRING VALLEY, NEW YORK 10977

ASK FOR OUR 64-PAGE CATALOG

*** ALL PRICES AND SPECIFICATIONS SUBJECT TO CHANGE ***

NEW TOLL-FREE
ORDER LINE
(OUTSIDE OF N.Y. STATE)
(800) 431-2818

AMERICAN EXPRESS

24 HOUR ORDER LINE
(914) 425-1535



Tired Of Your GENERAL LEDGER?

VERSA- LEDGER

FOR YOUR TRS-80 MODEL I, II, III or COLOR COMPUTER • APPLE II • I.B.M. • XEROX • ATARI
ALL MICROSOFT BASIC COMPUTERS

- ★ THE ULTIMATE PERSONAL CHECK REGISTER
- ★ A PROFESSIONAL ACCOUNTING SYSTEM
- ★ A PERSONAL FINANCIAL MANAGER
- ★ A SMALL BUSINESS ACCOUNTING SYSTEM
- ★ A COMPLETE GENERAL LEDGER

HOW IT WORKS

VERSALEDGER is a complete accounting system that grows as you or your business grows. To start, your **VERSALEDGER** acts as a simple method of keeping track of your checkbook. Just enter your check number, date and to whom the check is made out to. As you or your business grows, you may add more details to your transactions . . . account number, detailed account explanations, etc.

- **VERSALEDGER** can give you an instant cash balance at anytime. **(IF YOU WANT IT TO)**
- **VERSALEDGER** can be used as a small personal checkbook register. **(IF YOU WANT IT TO)**
- **VERSALEDGER** can be used to run your million dollar corporation. **(IF YOU WANT IT TO)**
- **VERSALEDGER** prints checks. **(IF YOU WANT IT TO)**
- **VERSALEDGER** stores all check information forever. **(IF YOU WANT IT TO)**
- **VERSALEDGER** can handle more than one checkbook. **(IF YOU WANT IT TO)**
- **VERSALEDGER** stores all check information forever. **(IF YOU WANT IT TO)**
- **VERSALEDGER** can be used to replace a general ledger. **(IF YOU WANT IT TO)**
- **VERSALEDGER HAS AN ALMOST UNLIMITED CAPACITY**
 (300 checks per month on single density 5¼" disk drives such as the TRS-80 Model-I)
 (500 checks per month on the Apple II)
 (2400 checks per month on the TRS-80 Model III)
 (6000 checks per month on the TRS-80 Model II)
 (3000 checks per month on single density 8" CP/M)
- **VERSALEDGER** will soon have an add-on payroll package. **(IF YOU NEED IT)**

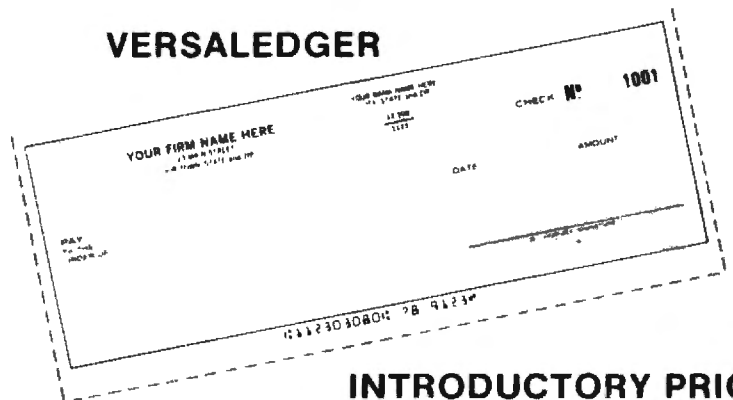

INTRODUCTORY PRICE
\$99.95

— CAN BE USED WITH 1 or MORE DISK DRIVES —

**VERSALEDGER HAS BEEN CREATED
WITH THE FIRST TIME COMPUTER USER IN MIND**

COMPUTRONICS
MATHEMATICAL APPLICATIONS

50 N. PASCACK ROAD
SPRING VALLEY, NEW YORK 10977

- ★ ADD \$3.00 FOR SHIPPING IN UPS AREAS
- ★ ADD \$4.00 FOR C.O.D. OR NON-UPS AREAS
- ★ ADD \$5.00 TO CANADA AND MEXICO
- ★ ADD PROPER POSTAGE OUTSIDE U.S., CANADA & MEXICO



24 HOUR
ORDER
LINE

(914) 425-1535



**NEW TOLL-FREE
ORDER LINE**
(OUTSIDE OF N.Y. STATE)

(800) 431-2818

*** ALL PRICES & SPECIFICATIONS SUBJECT TO CHANGE ***

PAYROLL SIMPLIFIED

VERSA PAYROLL

- ★ THE ULTIMATE PROFESSIONAL PAYROLL SYSTEM
- ★ HANDLES ALL PAYROLL FUNCTIONS AND REPORTS
- ★ QUICK QUARTERLY AND END OF YEAR SUMMARIES
- ★ PERFECT FOR A SMALL BUSINESS
- ★ EXPANDS TO HANDLE LARGE CORPORATE PAYROLLS

FOR YOUR TRS-80* MODEL I, II, III, IV • APPLE* • I.B.M.* • XEROX* • ATARI*
ALL MICROSOFT BASIC COMPUTERS

* TRS-80 is a trademark of Tandy Corp. - *APPLE is a trademark of Apple Corp. - *I.B.M. is a trademark of I.B.M. Corp. - *XEROX is a trademark of Xerox Corp. - *ATARI is a trademark of Atari Inc.

HOW IT WORKS

VERSAPAYROLL is a complete menu driven payroll system that grows as you or your business grows. Your **VERSAPAYROLL** acts as a simple payroll system keeping track of all government required payroll information. Just enter the employees. **VERSAPAYROLL** will perform all the necessary payroll calculations automatically and display to totals on your screen. The user has complete control to accept the totals, to print or not print out a check and to post or not post the total to our **VERSALEDGER** system.

- **VERSAPAYROLL** automatically prints out your **PAYROLL** checks. **(IF YOU WANT IT TO)**
- **VERSAPAYROLL** allows you to override any payroll deduction. **(IF YOU WANT IT TO)**
- **VERSAPAYROLL** automatically posts all checks written to our **VERSALEDGER** system. **(IF YOU WANT IT TO)**
- **VERSAPAYROLL** allows the user to print out **PAYROLL** checks one at a time. **(IF YOU WANT IT TO)**
- **VERSAPAYROLL** allows the user to print out all your **PAYROLL** checks at the same time. **(IF YOU WANT IT TO)**
- **VERSAPAYROLL** gives you a summary of any employee's year to date payroll totals or all employee totals at any time. **(IF YOU WANT IT TO)**
- **VERSAPAYROLL** will allow you to correct any error made at any time and automatically refigure all totals **(IF YOU WANT IT TO)**
- **VERSAPAYROLL** works in every state. **(IF YOU WANT IT TO)**
- **VERSAPAYROLL** automatically calculates all federal and states taxes **(IF YOU WANT IT TO)**
- **VERSAPAYROLL** allows for all of the standard deductions plus state, city and three miscellaneous deductions. **(IF YOU WANT IT TO)**
- **VERSAPAYROLL** prints all government required reports. **(IF YOU WANT IT TO)**
- **VERSAPAYROLL** permanently stores all **PAYROLL** transactions **(IF YOU WANT IT TO)**
- **VERSAPAYROLL** HAS AN ALMOST UNLIMITED CAPACITY

Can handle up to 300 employees on a TRS-80 MODEL I, 600 employees on a TRS-80 MODEL III, 1200 employees on a TRS-80 MODEL II, 500 employees on an APPLE II, 600 employees on any single density 8" CP/M computer and almost unlimited capacity on hard disk systems.

CAN BE USED WITH 1 or MORE DISK DRIVES (AND 48K)

**VERSAPAYROLL HAS BEEN CREATED
WITH THE FIRST TIME COMPUTER USER IN MIND**

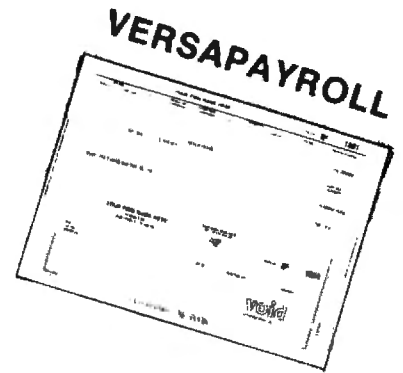

INTRODUCTORY PRICE
\$99.95

COMPUTRONICS
MATHEMATICAL APPLICATIONS SERVICE

50 N. PASCACK ROAD
SPRING VALLEY, NEW YORK 10977

ADD \$3.00 FOR SHIPPING IN UPS AREAS
ADD \$4.00 FOR C.O.D. OR NON-UPS AREAS
ADD \$5.00 TO CANADA AND MEXICO
ADD PROPER POSTAGE OUTSIDE OF U.S.,
CANADA AND MEXICO

NEW TOLL-FREE
ORDER LINE
(OUTSIDE OF N.Y. STATE)
(800) 431-2818

*** ALL PRICES AND SPECIFICATIONS SUBJECT TO CHANGE ***



24 HOUR
ORDER
LINE



(914) 425-1535

THE COLLECTOR!

VERSA- RECEIVABLES

- ★ THE ULTIMATE ACCOUNTS RECEIVABLE SYSTEM
- ★ HANDLES ALL ACCOUNTS RECEIVABLE FUNCTIONS
- ★ QUICK PERIODIC SUMMARIES AND REPORTS
- ★ PERFECT FOR PERSONAL OR BUSINESS USE
- ★ EXPANDS TO HANDLE LARGE CORPORATE RECEIVABLES

FOR YOUR SYSTEM: MODEL I, II, III • APPLE • I.B.M. • XEROX • ATARI
AND MICROSOFT BASIC COMPUTERS

*TRS-80 is a trademark of Tandy Corp. - *APPLE is a trademark of Apple Corp. - *I.B.M. is a trademark of I.B.M. Corp. - *XEROX is a trademark of Xerox Corp. - *ATARI is a trademark of Atari Inc.

HOW IT WORKS

VERSARECEIVABLES is a complete menu driven accounts receivable system. It keeps track of all information related to who owes you or your company money. It prints all necessary statements, invoices and all summary reports to keep you in touch with the flow of money owed to your company. In short, **VERSARECEIVABLES** is a complete invoicing and monthly statement generating system which keeps track of current and past due receivables.

- VERSARECEIVABLES invoices your customers. (IF YOU WANT IT TO)
- VERSARECEIVABLES prints customer mailing labels. (IF YOU WANT IT TO)
- VERSARECEIVABLES generates monthly (or periodic) statements at any time. (IF YOU WANT IT TO)
- VERSARECEIVABLES uses commonly available preprinted statements and invoices. (IF YOU WANT IT TO)
- VERSARECEIVABLES allows partial payments on open invoices. (IF YOU WANT IT TO)
- VERSARECEIVABLES prints out all commonly used ACCOUNTS RECEIVABLE reports to give you a total picture of money owed to your company. (IF YOU WANT IT TO)
- VERSARECEIVABLES keeps a history of each account, both current and aged. (IF YOU WANT IT TO)
- VERSARECEIVABLES is ideal for doctors, lawyers, small and large businesses.
- VERSARECEIVABLES HAS AN ALMOST UNLIMITED CAPACITY

400 customers and transactions per month on single density 5 1/4" disk drives such as the TRS-80 Model I	
600 per month on the APPLE II	
2400 per month on the TRS-80 MODEL III	3000 per month on single density 8" CP/M
6000 per month on the TRS-80 MODEL II	Almost unlimited on hard disk drive systems

Above capacities are estimates and depend on the customer-transaction mix and the amount of disk space available.

**VERSARECEIVABLES HAS BEEN CREATED
WITH THE FIRST TIME COMPUTER USER IN MIND**

VERSARECEIVABLES

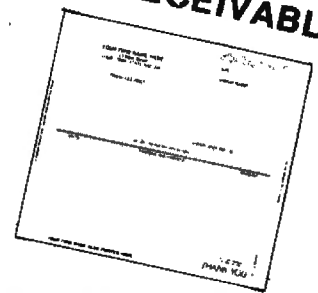

**INTRODUCTORY PRICE
\$99.95**

COMPUTRONICS
MATHEMATICAL APPLICATIONS SERVICE

50 N. PASCACK ROAD
SPRING VALLEY, NEW YORK 10977

ADD \$3.00 FOR SHIPPING IN UPS AREAS
ADD \$4.00 FOR C.O.D. OR NON-UPS AREAS
ADD \$5.00 TO CANADA AND MEXICO
ADD PROPER POSTAGE OUTSIDE OF U.S.,
CANADA AND MEXICO

NEW TOLL-FREE
ORDER LINE
(OUTSIDE OF N.Y. STATE)
(800) 431-2818

*** ALL PRICES AND SPECIFICATIONS SUBJECT TO CHANGE***

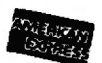

24 HOUR
ORDER
LINE



(914) 425-1535

HOW MUCH MONEY DO YOU OWE?

VERSA^{□□} PAYABLES

- ★ THE ULTIMATE ACCOUNTS PAYABLE SYSTEM
- ★ HANDLES ALL ACCOUNTS PAYABLE FUNCTIONS
- ★ QUICK PERIODIC SUMMARIES AND REPORTS
- ★ PERFECT FOR PERSONAL OR BUSINESS USE
- ★ EXPANDS TO HANDLE LARGE CORPORATE PAYABLES

FOR YOUR TRS-80* MODEL I, II, III, 1G • APPLE* • I.B.M.* • XEROX* • ATARI*
ALL MICROSOFT BASIC COMPUTERS

* TRS-80 is a trademark of Tandy Corp. - * APPLE is a trademark of Apple Corp. - * I.B.M. is a trademark of I.B.M. Corp. - * XEROX is a trademark of Xerox Corp. - * ATARI is a trademark of Atari Inc.

HOW IT WORKS

VERSAPAYABLES is a complete menu driven accounts payable system. It keeps track of all information related to how much money you (personally) or your company owes. It prints all necessary checks and statements on easily obtainable tractor feed forms (or on plain paper). Prints all summary reports to keep you in touch with the flow of money going out of your hands (or leaving your company). In short, **VERSAPAYABLES** is designed to keep track of current and aged payables. The system maintains a complete record of each vendor, helps determine which transactions to pay by due date within certain cash requirements and prints checks automatically with a detailed check register.

- **VERSAPAYABLES** prints out your checks. (IF YOU WANT IT TO)
- **VERSAPAYABLES** prints out a detailed check register. (IF YOU WANT IT TO)
- **VERSAPAYABLES** allows for full or partial payments. (IF YOU WANT IT TO)
- **VERSAPAYABLES** prints out vendor mailing labels. (IF YOU WANT IT TO)
- **VERSAPAYABLES** prints out all commonly used ACCOUNTS PAYABLE reports to give you a total picture of money you or your company owes. (IF YOU WANT IT TO)
- **VERSAPAYABLES** integrates with **VERSALEDGER**. (IF YOU WANT IT TO)
- **VERSAPAYABLES** HAS AN ALMOST UNLIMITED CAPACITY
 - 400 vendors and transactions per month on single density 5 1/4" disk drives such as the TRS-80 MODEL I
 - 600 per month on the APPLE II
 - 2400 per month on the TRS-80 MODEL III
 - 6000 per month of the TRS-80 MODEL II
 - 3000 per month on single density 8" CP/M
 - Almost unlimited capacity on hard disk drive systems

Above capacities are estimates and depend on disk space available and your vendor-transaction mix

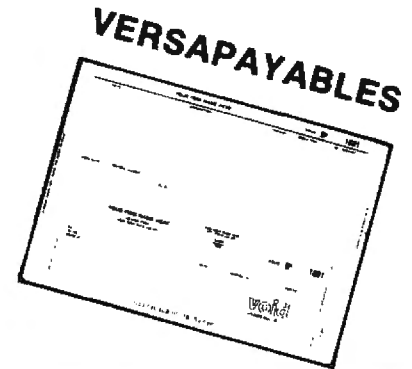

INTRODUCTORY PRICE
\$99.95

**VERSAPAYABLES HAS BEEN CREATED
WITH THE FIRST TIME COMPUTER USER IN MIND**

COMPUTRONICS
MATHEMATICAL APPLICATIONS SERVICE

50 N. PASCACK ROAD
SPRING VALLEY, NEW YORK 10977

ADD \$3.00 FOR SHIPPING IN UPS AREAS
ADD \$4.00 FOR C.O.D. OR NON-UPS AREAS
ADD \$5.00 TO CANADA AND MEXICO
ADD PROPER POSTAGE OUTSIDE OF U.S.
CANADA AND MEXICO

NEW TOLL-FREE
ORDER LINE
(OUTSIDE OF N.Y. STATE)
(800) 431-2818

*** ALL PRICES AND SPECIFICATIONS SUBJECT TO CHANGE***



24 HOUR
ORDER
LINE

(914) 425-1535

HOW MANY DO YOU HAVE LEFT?

VERSA- INVENTORY

- ★ THE ULTIMATE INVENTORY SYSTEM
- ★ HANDLES ALL INVENTORY FUNCTIONS
- ★ QUICK PERIODIC SUMMARIES AND REPORTS
- ★ PERFECT FOR PERSONAL OR BUSINESS USE
- ★ EXPANDS TO HANDLE LARGE CORPORATE INVENTORIES

FOR WHICH THE TRS-80* MODEL II, III, IV, V6 • APPLE* • I.B.M.* • XEROX* • ATARI*
AND MICROSOFT BASIC COMPUTERS

*TRS-80 is a trademark of Tandy Corp. - *APPLE is a trademark of Apple Corp. - *I.B.M. is a trademark of I.B.M. Corp. - *XEROX is a trademark of Xerox Corp. - *ATARI is a trademark of Atari Inc.

HOW IT WORKS

VERSAINVENTORY is a complete menu driven inventory control system. It keeps track of all information related to how many of a particular item you have. It prints all necessary inventory reports and gives you instant access to any inventory item. **VERSAINVENTORY** allows the user to stay in touch with items that directly affect sales. Update **INVENTORY** through easy **MENU** driven processes.

- **VERSAINVENTORY** allows the user to instantly add to or deduct from **INVENTORY**. **(IF YOU WANT IT TO)**
- **VERSAINVENTORY** handles reorder point levels. **(IF YOU WANT IT TO)**
- **VERSAINVENTORY** gives period-to-date and year-to-date sales reports. **(IF YOU WANT IT TO)**
- **VERSAINVENTORY** can be linked to **VERSARECEIVABLES** and **VERSALEDGER**. **(IF YOU WANT IT TO)**
- **VERSAINVENTORY** gives all standard **INVENTORY REPORTS**. **(IF YOU WANT IT TO)**
- **VERSAINVENTORY** instantly values your **INVENTORY**. **(IF YOU WANT IT TO)**
- **VERSAINVENTORY** HAS AN ALMOST UNLIMITED CAPACITY

**INTRODUCTORY
PRICE
\$99.95**

To figure out estimated **VERSAINVENTORY** limitations, just multiply 8 by the number of kilobytes of disk storage available. For example, the store capacity on a TRS-80 MODEL II disk drive is 500K. That will allow the user to have about 4,000 inventory items on record. This total is an estimate and depends on how you set up your inventory system.

**VERSAINVENTORY HAS BEEN CREATED
WITH THE FIRST TIME COMPUTER USER IN MIND**

COMPUTRONICS
MATHEMATICAL APPLICATIONS SERVICE

50 N. PASCACK ROAD
SPRING VALLEY, NEW YORK 10977

ADD \$3.00 FOR SHIPPING IN UPS AREAS
ADD \$4.00 FOR C.O.D. OR NON-UPS AREAS
ADD \$5.00 TO CANADA AND MEXICO
ADD PROPER POSTAGE OUTSIDE OF U.S.,
CANADA AND MEXICO

NEW TOLL-FREE
ORDER LINE
(OUTSIDE OF N Y STATE)
(800) 431-2818



24 HOUR
ORDER
LINE



*** ALL PRICES AND SPECIFICATIONS SUBJECT TO CHANGE ***

✓⁹ **(914) 425-1535**

NEW
from **MICRO SYSTEMS**
SOFTWARE INC.

DOSPLUS

VERSION 3.4
MODEL I
or MODEL III

MODEL III DOSPLUS READY NOW! That's right! DOSPLUS 3.3 for the MODEL III is available now. We have our MODEL III, and now you can have our DOS. All the great features of our popular MODEL I DOS, plus Single or Double Density Operation. The best gets better! Order now, and soon your MODEL III will be all the computer it can be. Experience excellence. Experience DOSPLUS. **\$149.95**

DOSPLUS! The flagship of the Micro-Systems line. This is the BEST disk operating system currently available. It offers you all the features you could ever use, speed, reliability, and much more! Full support of variable length records. No more internal errors during file handling due to poorly written operating systems. Allows use of ISAM technique. Supports 35-80 track drives. The two operating systems are basically the same. However, Dosplus 3.4D will operate double density. The double density DOS has some differences peculiar to double density operation. Both systems offer DOS commands from BASIC, BASIC renum, and BASIC program compressor. DOS utilities include a sector display/modify program, a utility to purge files, AND a utility to restore purged or killed files. Free space map and the most comprehensive directory on the market. Try it and you'll never use anything else. All this and much more for only \$149.95 either system.

THE ORIGINAL DOSPLUS CONTAINS ALL OF THE FOLLOWING FEATURES

- 1) Radio Shack compatibility
- 2) Error free variable length records
- 3) Full lower case detection and support
- 4) Repeating keyboard with NO keybounce EVER
- 5) Shift [0] typewriter keyboard option
- 6) Execute only protection feature for BASIC programs
- 7) Automatic track support for 35 through 80 track drives (mixed)
- 8) Device I/O handling with FORCE command
- 9) Supports high speed clock modification (up to 4.0Mhz)
- 10) Supports mixed mode (single & double density) automatically
- 11) Allows disable-enable to break key
- 12) Allows user to define step rate per drive and re-configure system disk
- 13) Allows for efficient use of double-headed drives
- 14) Built in screen printer (shift [CLEAR] with [BREAK] key abort)
- 15) Multiple command chaining with "DO"
- 16) Built in memory test with CLEAR command
- 17) New printer driver which allows complete forms control and paging
- 18) Automatic serial printer driver with optional auto linefeed
- 19) Execute any DOS command from BASIC and return to BASIC
- 20) Free space map of diskette with optional output to printer
- 21) Copy with variable length files
- 22) Complete RS232 control from keyboard with status check
- 23) Create and pre-allocate files from DOS
- 24) Display current date and time from DOS
- 25) More information from Directory with optional printer output
- 26) Enter DEBUG with shift [BREAK] to allow use of [BREAK] from BASIC
- 27) New DISKDUMP/CMD sector display/modify program (works with filespecs)
- 28) New DISKZAP/CMD single/double density disk editor
- 29) New BACKUP (more reliable, no more pack ID check)
- 30) New FORMAT (more reliable, no need to bulk erase disk first)
- 31) New MAP utility (maps out disk, showing where files are located)

PLUS

**** 7 MORE UTILITIES ****

- 1) Single drive copy
- 2) Restore (dead files)
- 3) Purge (unwanted files)
- 4) Clearfile (destroys data by writing zeros to file)
- 5) Transfer (moves all user files from one disk to another)
- 6) Spooler (allows printing of text while freeing up the CPU)
- 7) Crunch (Basic program compressor)

NOW

DOSPLUS 3.4 ADDS THESE NEW ADDITIONAL FEATURES

1. BASIC array sort - multi key, multi array
2. Tape/Disk - Disk/Tape utility (with relocater)
3. Input@ (controlled screen input)
4. Random access and ASCII modification on Diskdump
5. BASIC checks for active 'DO'
6. Backup and Format from a 'DO' file
7. Much improved Backup (More reliable)
8. I/O package much faster (disk access time reduced)
9. Repeat last DOS command with '/' ENTER
10. Short directory (file name and extension) available
11. Short directory of Model III TRSDOS disks
12. Single file convert from Model III TRSDOS
13. COMPLETE device routing supported (DOS and BASIC)
14. Ability to save BASIC programs directly to another machines' memory (if equipped with Dosplus 3.4)
 - Plus many more improvements
 - Includes the new expanded easy to read 200 + page users guide
 - Also includes the new DOSPLUS Z80 disk basic VER 1.6

PLUS New DOSPLUS Z80 Extended Disk BASIC

- 1) Faster loads and saves
- 2) BASIC Reference utility (lines, variables, keywords, printer option)
- 3) BASIC Renumber utility (renumber section of text, block text move)
- 4) Shorthand features for almost ANY direct command (LOAD, SAVE, etc.)
- 5) Shorthand features for editing (listing and editing with single key)
- 6) CMD "M" instantly displays currently set variables
- 7) Global search and replace in BASIC text
- 8) Line printer TAB to 255
- 9) OPEN "E" to end of sequential file (for output)
- 10) DI (delete and insert text line)
- 11) DU (duplicate text line)
- 12) "R" & "V" options after LOAD and RUN (files open & save variable)
- 13) OPEN "D" allowed (Model II compatible) equal to OPEN "R"
- 14) DOS commands from BASIC
- 15) Automatic, error-free variable length records
- 16) Single step execution with TRON (fabulous for debugging)
- 17) CRUNCH (BASIC program compressor)
- 18) New TBASIC (tiny BASIC) offers full BASIC commands
- 19) TBASIC and DOSPLUS together only use BK of RAM (40K left in 48K TRS-80)

COMPUTRONICS
INTERNATIONAL

50 N. PASCACK ROAD
SPRING VALLEY, NEW YORK 10977

- ★ All orders processed within 24-Hours
- ★ 30-Day money back guarantee on all Software
- ★ Add \$3.00 for shipping in UPS Areas
- ★ Add \$4.00 for C.O.D. or NON-UPS Areas within U.S.A.
- ★ Add \$5.00 to Canada and Mexico
- ★ Add proper postage outside of U.S., Canada and Mexico



DOSPLUS—\$149.95
(MODEL I or MODEL III)

Dealers Call
Micro Systems Software
(800) 327-8724

NEW TOLL-FREE
ORDER LINE

(OUTSIDE OF N.Y. STATE)

(800) 431-2818



24 HOUR
ORDER
LINE

(914) 425-1535

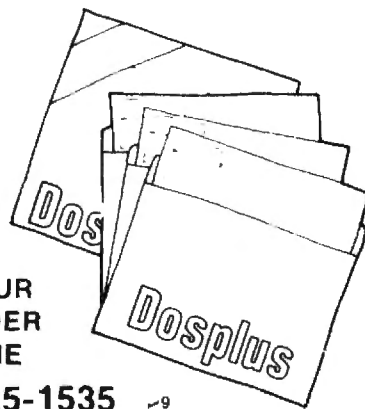

H & E COMPUTRONICS I N C.

● ● ● EVERYTHING FOR YOUR TRS-80* ● ● ● MODEL I, MODEL II & MODEL III

* TRS-80™ is a trademark of Tandy Corp

FROM

 RACET COMPUTES LTD 

- All orders processed within 24 Hours
- 30-Day money back guarantee
- Add \$3.00 for shipping in UPS Areas
- Add \$4.00 for C.O.D. or NON-UPS Areas
- Add \$5.00 to Canada or Mexico
- Add exact postage to all other countries

*** ESSENTIAL UTILITY PROGRAMS FOR EVERY TRS-80 OWNER ***

Facts About Racet Computes Utility Programs

- *** ALL PROGRAMS ARE WRITTEN IN MACHINE LANGUAGE
- *** ABSOLUTELY NO KNOWLEDGE OF MACHINE LANGUAGE IS NECESSARY TO USE ANY OF THE UTILITY PROGRAMS
- *** EACH UTILITY PROGRAM IS CALLED UP FROM BASIC USING THE SIMPLE BASIC COMMANDS PROVIDED
- *** EACH UTILITY PROGRAM COMES WITH A RACET COMPUTES INSTRUCTION MANUAL
- *** EACH INSTRUCTION MANUAL INCLUDES SEVERAL EXAMPLES OF UTILITY USAGE
- *** EACH UTILITY ALLOWS THE USER TO PERFORM CERTAIN BASIC OPERATIONS TEN, TWENTY OR MORE TIMES FASTER THAN THE EQUIVALENT BASIC ROUTINE (FOR EXAMPLE, GSF CAN SORT AN ARRAY OF 1000 RANDOM NAMES INTO ALPHABETICAL ORDER IN UNDER 9 SECONDS!!)

GSF (GENERALIZED SUBROUTINE FACILITY)

- SORTS 1000-ELEMENT ARRAYS IN 9 SECONDS
- SORTS UP TO 15 ARRAYS SIMULTANEOUSLY (MIXED STRING, FLOATING POINT AND INTEGER)
- SORTS SINGLE OR MULTIPLE SUBSTRINGS AS ASCENDING OR DESCENDING SORT KEYS
- READ AND WRITE ARRAYS TO CASSETTE
- COMPRESS AND UNCOMPRESS DATA IN MEMORY
- MOVE ARRAYS IN MEMORY
- DUPLICATE MEMORY
- FAST HORIZONTAL AND VERTICAL LINES
- SCREEN CONTROLS FOR SCROLLING THE SCREEN UP, DOWN, LEFT, RIGHT AND FOR GENERATING INVERSE GRAPHIC DISPLAYS
- ADDS PEEKS AND POKES (MOD-II VERSION ONLY)

MODEL-I VERSION \$25.00
 MODEL-II VERSION \$50.00
 MODEL-III VERSION \$30.00

KFS-80 (KEYED FILE SYSTEM)

- CREATE ISAM FILES (INDEX SEQUENTIAL ACCESS METHOD)
- ALLOWS INSTANT ACCESS TO ANY RECORD ON YOUR DISKETTE
- INSTANTLY RETRIEVE RECORDS FROM MAILING LISTS, INVENTORY, ACCOUNTS RECEIVABLE OR VIRTUALLY ANY APPLICATION WHERE RAPID ACCESS IS REQUIRED TO NAMED RECORDS
- PROVIDES THE BASIC PROGRAMMER THE ABILITY TO RAPIDLY INSERT OR ACCESS KEYED RECORDS IN ONE OR MORE DATA FILES
- RECORDS ARE MAINTAINED IN SORTED ORDER BY A SPECIFIED KEY
- RECORDS MAY BE INSERTED OR RETRIEVED BY SUPPLYING THE KEY
- RECORDS MAY BE RETRIEVED SEQUENTIALLY IN SORTED ORDER
- RAPID ACCESS TO ANY FILE REGARDLESS OF THE NUMBER OF RECORDS
- MULTIPLE INDEX FILES CAN BE EASILY CREATED WHICH ALLOWS ACCESS OF A SINGLE DATABASE BY MULTIPLE KEYS (FOR EXAMPLE BY BOTH NAME AND ZIP-CODE)

MODEL-I VERSION \$100.00
 MODEL-II VERSION \$175.00
 MODEL-III VERSION \$100.00

DSM (DISK SORT MERGE)

- SORT AN 85K DISKETTE IN LESS THAN THREE MINUTES
- SORTS LARGE MULTIPLE DISKETTE FILES ON A MINIMUM ONE DRIVE SYSTEM
- ALL RECORDS ARE PHYSICALLY REARRANGED, NO KEY FILES ARE REQUIRED
- SORTS RANDOM FILES CREATED BY BASIC, INCLUDING FILES CONTAINING SUB-RECORDS SPANNING SECTORS
- SORTS ON ONE OR MORE FIELDS IN ASCENDING OR DESCENDING ORDER
- FIELDS MAY BE STRINGS, INTEGER, BINARY INTEGER OR FLOATING POINT
- THE SORTED OUTPUT FILE MAY OPTIONALLY HAVE FIELDS DELETED, REARRANGED OR PADDED
- SORT COMMANDS CAN BE SAVED FOR REUSE
- SINGLE SORT, MERGE OR MIXED SORT, MERGE OPERATIONS MAY BE PERFORMED
- SORTED OUTPUT MAY BE WRITTEN TO A NEW FILE OR REPLACE THE ORIGINAL INPUT FILE

MODEL-I VERSION \$75.00
 MODEL-II VERSION \$150.00
 MODEL-III VERSION \$90.00

MAILLIST (A MAILING LIST DATABASE SYSTEM)

- IDEALLY SUITED FOR ORGANIZATION MAILING LISTS, PERSONAL ADDRESSBOOK, OR MAILING LISTS BASED ON DATES SUCH AS REMINDERS FOR BIRTHDATES OR DUES PAYABLE
- USED ISAM (INDEX SEQUENTIAL ACCESS METHOD) FOR RAPID ACCESS TIMES
- YOUR MAILLIST CAN ALWAYS BE SORTED AND MAINTAINED BY UP TO FOUR INDEX FILES (FOR EXAMPLE, NAME, ZIPCODE, DATE AND NUMBER)
- MAILLIST ALLOWS UP TO 30 ATTRIBUTES TO BE SPECIFIED (TO BE USED IN SELECTION OF SPECIFIED RECORDS WHEN GENERATING REPORTS OR MAILING LABELS)
- MAILLIST SUPPORTS BOTH 5 OR 9-DIGIT ZIPCODES
- PRINTING MAY BE STARTED OR ENDED AT ANY POINT IN THE LIST. THE USER CAN SPECIFY FIELDS OR CODES TO BE PRINTED
- CAPACITY IS 600 NAMES FOR MODEL-I, 3500 NAMES FOR MODEL-II, 38,000 NAMES FOR MODEL-II WITH HARD DISK DRIVE, 1200 NAMES FOR MODEL-III

MODEL-I VERSION \$75.00
 MODEL-II VERSION \$150.00
 MODEL-III VERSION \$75.00

COMPUTRONICS INC.

HSDS HARD DISK DRIVE SOFTWARE

- MAKES TRSDOS COMPATIBLE WITH MOST HARD DISK DRIVES
- ADDS MANY EXTRA FEATURES TO TRSDOS..... \$400.00

MODEL II FASTBACK — FULL DISK BACKUP IN 55 SECONDS

- IN BUSINESS TIME IS MONEY, AND ONE BACKUP IS WORTH A THOUSAND TEARS.
- WORKS ON SYSTEMS WITH 2 OR MORE DRIVES
- CAN REPLACE YOUR EXISTING TRSDOS 1.2 OR 2.0 BACKUP UTILITY

MODEL II ONLY \$75.00

COMPROC (COMMAND PROCESSOR)

- AUTO YOUR DISK TO PERFORM ANY SEQUENCE OF INSTRUCTIONS THAT YOU NORMALLY GIVE FROM THE KEYBOARD (FOR EXAMPLE, INSERT THE DISKETTE, PRESS THE RESET BUTTON, YOUR COMMAND FILE COULD AUTOMATICALLY SHOW YOU THE DIRECTORY, SHOW THE FREE SPACE ON THE DISKETTE, LOAD A MACHINE LANGUAGE SUBROUTINE, LOAD BASIC, LOAD AND RUN A BASIC PROGRAM AND SELECT A GIVEN ITEM ON YOUR MENU ALL WITHOUT TOUCHING THE KEYBOARD)

MODEL-I VERSION \$20.00
 MODEL-III VERSION \$30.00
 NOT AVAILABLE FOR MODEL-II

DISCAT (DISKETTE CATALOG SYSTEM)

- THIS COMPREHENSIVE DISKETTE CATALOGUING/INDEXING UTILITY ALLOWS THE USER TO KEEP TRACK OF THOUSANDS OF PROGRAMS IN A CATEGORIZED LIBRARY. FILE INCLUDES PROGRAM NAMES AND EXTENSIONS PROGRAM LENGTH, DISKETTE NUMBERS AND FREE SPACE ON EACH DISKETTE. KEEP A COMPLETE CATALOG OF THE DIRECTORIES ON ALL YOUR DISKETTES IN ALPHABETICAL ORDER (SORTED ON EACH DISKETTE OR COMPLETE ALPHABETICAL LIST OF PROGRAMS ON ALL YOUR DISKETTES)

MODEL-I VERSION \$50.00
 MODEL-III VERSION \$50.00
 MODEL-II VERSION (SEE MODEL-II UTILITY PACKAGE)

BLINK (BASIC LINK FACILITY)

- LINK FROM BASIC PROGRAM TO ANOTHER SAVING ALL VARIABLES
- THE CHAINED PROGRAM MAY EITHER REPLACE THE ORIGINAL PROGRAM OR CAN BE MERGED BY STATEMENT NUMBER

MODEL-I VERSION \$25.00
 MODEL-III VERSION \$50.00
 MODEL-II VERSION (SEE MODEL-II UTILITY PACKAGE) \$30.00

INFINITE BASIC

- ADDS OVER 80 COMMANDS TO BASIC
- SORTING STRING CENTERING/ROTATION/TRUNCATION JUSTIFICATION DATA COMPRESSION STRING TRANSLATION/COPYING SCREEN DISPLAY SCROLLING MATRIX OPERATIONS SIMULTANEOUS EQUATIONS (THROUGH MATRIX INVERSION). DYNAMIC ARRAY RESHAPING

MODEL-I VERSION \$50.00
 MODEL-III VERSION \$60.00
 NOT AVAILABLE ON MODEL-II

INFINITE BUSINESS

- ADD ON PACKAGE TO INFINITE BASIC (REQUIRES INFINITE BASIC)
- ADDS PACKED DECIMAL ARITHMETIC WITH 127 DIGIT ACCURACY (+.0..)
- COMPLETE PRINTER PAGINATION CONTROLS AUTO HEADERS FOOTERS AND PAGE NUMBERS
- BINARY SEARCH OF SORTED AND UNSORTED ARRAYS (INSTANT SEARCH OF AN ELEMENT WITHIN AN ARRAY)
- HASH CODES

MODEL-I VERSION \$30.00
 MODEL-III VERSION \$30.00
 NOT AVAILABLE ON MODEL-II

REMDEL-PROLOAD

- THE ULTIMATE RENUMBERING PROGRAM RENUMBERS ALL OR PART OF A PROGRAM (ALLOWS PARTIAL RENUMBERING IN MIDDLE OF PROGRAMS)
- PARTIAL OR COMPLETE MERGE OF TWO CASSETTE PROGRAMS

MODEL-I VERSION \$35.00
 MODEL-III VERSION \$35.00
 NOT AVAILABLE ON MODEL-II

COPSYS

- COPY AND VERIFY ALL MACHINE LANGUAGE (SYSTEM) TAPES WRITTEN IN STANDARD FORMAT IF YOU BUY A MACHINE LANGUAGE PROGRAM COPSYS ALLOWS YOU TO EASILY COPY THE PROGRAM ONTO ANOTHER CASSETTE AS A BACKUP

MODEL-I VERSION \$15.00
 MODEL-III VERSION \$20.00
 NOT AVAILABLE ON MODEL-II

MODEL-II UTILITY PACKAGE

- ESSENTIAL FOR EVERY MOD-II OWNER
- RECOVER AND REPAIR FILES AND DIRECTORIES (BY JUST ENTERING A SINGLE COMMAND)
- XCOPY SIMILAR TO COPY BUT CAN COPY ANY NUMBER OF FILES AT ONE TIME FASTER AND MORE ACCURATE THAN COPY SINCE RECORDS ARE COPIED IN GROUPS RATHER THAN ONE RECORDS AT A TIME USING XCOPY YOU CAN COPY FILES THAT CAN NOT BE COPIED USING THE COPY COMMAND
- SZAP PROVIDES THE CAPABILITY TO READ AND MODIFY ANY SECTOR ON A DISKETTE
- XHIT CAN BE USED TO REPAIR A DISKETTE DIRECTORY
- DCS DIRECTOR CATALOG SYSTEM IS A UTILITY FOR THE MANAGEMENT OF USER DISKETTES SETS OF A MULTIPLE DISKETTE DIRECTORY FILE (WITH UP TO 1200 INDIVIDUAL FILE NAMES) ALLOWS SELECTIVELY LISTED OR PRINTED LISTS OF DIRECTORY FILES IN COMBINED SORTED ORDER (FOR EXAMPLE, LISTED ALPHABETICALLY BY DISKETTE OR A COMPOSITE ALPHABETICAL LIST OF ALL YOUR DISKETTES)
- DEBUG II ADDS SEVERAL FEATURES TO THE PRESENT TRSDOS DEBUG UTILITY INCLUDING SINGLE INSTRUCTION CYCLE, AUTO (LOOP) BREAKPOINTS, SUBROUTINE CALLING, BREAK-KEY DETECTION AND MANY OTHERS

MODEL-II ONLY \$150.00

MODEL-II DEVELOPMENT SYSTEM

- THIS PACKAGE IS A MUST FOR ASSEMBLY LANGUAGE PROGRAMMERS
- INCLUDES THE MICROSOFT EDITOR ASSEMBLER PLUS WITH ENHANCEMENTS FOR THE MODEL-II
- A COMPLETE DISASSEMBLER
- SUPERZAP FOR READING AND MODIFY ANY SELECTOR ON A DISKETTE

MODEL-II ONLY \$125.00

MOD-II BASIC CROSS REFERENCE UTILITY

- LIST OR PRINT A SORTED CROSS REFERENCE TO ALL NUMBERS OR VARIABLES WITHIN A PROGRAM
- LIST OF PRINT ALL LINE NUMBERS CONTAINING A SPECIFIED STRING OF CHARACTERS

MODEL-II ONLY \$50.00

*** ALL PRICES AND SPECIFICATIONS SUBJECT TO CHANGE ***

END USERS
CALL:



50 N. PASCACK ROAD
SPRING VALLEY, NEW YORK 10977

NEW TOLL-FREE
ORDER LINE
(OUTSIDE OF NY STATE)
(800) 431-2818



24 HOUR
ORDER
LINE



(914) 425-1535

ADD \$3.00 FOR SHIPPING IN UPS AREAS
ADD \$4.00 FOR C.O.D. OR NON-UPS AREAS
ADD \$5.00 TO CANADA AND MEXICO
ADD PROPER POSTAGE OUTSIDE OF U.S.
CANADA AND MEXICO

FOR DEALER
INFORMATION CALL:



1330 N. GLASSEL, SUITE M, ORANGE CA 92667
(714) 997-4950

If you're not running Small Business Systems Group software . . . chances are you're not running!

**EXPERIENCE SHOWS
S.B.S.G.
Has Over
11,000
Installed Systems!**

General Ledger

The General Ledger accounting system consolidates financial data from other accounting subsystems in an accurate and timely manner. Major reports include Trial Balance, Income Statement, Balance Sheet, a user-defined report,

Accounts Receivable

The objective of a computerized A/R system is to prepare accurate and timely monthly statements to credit customers. Management can generate information required to control the amount of credit extended and the collection of money owed in order to maximize profitable credit sales while minimizing losses from bad debts. This system is invoice-oriented. Invoices can be entered before they're ready for billing, after billing, or even after they are paid. Accounts Receivable allows entry of new invoices, credit memos, debit memos, or modi-

Order Entry

The Order Entry Module was designed as a supplement to the Accounts Receivable Module, and will not operate independently. This system allows you to add, change, delete, list and print invoices, apply an invoice to correct customer account; generate computer assigned invoice numbers; note type (invoice credit memo, debit memo); record customer order number, invoice date, shipping date, FOB location, method of shipping, salesman, and payment terms; print selected number of shipping labels; enter, display and correct 10 lines of data per invoice, noting the part number, description, price, quantity

Accounts Payable

The Accounts Payable system receives data concerning purchases from suppliers and produces checks in payment of outstanding invoices. Several reports are available to supply information needed for the analysis of payments, expenses, purchases and cash requirements. The Accounts Payable system is invoice-oriented. It handles new invoices, credit memos and even debit memos and allows modification and deletion of invoices. The flexible check calculation procedures allows checks to be calculated for a set of vendors, specific vendors

Payroll

Payroll involves many complex calculations and the production of reports and documents, many of which are required by government agencies. The Payroll system performs all necessary payroll tasks including file maintenance, pay data entry and verification, computation of pay and deduction amounts, and the

Inventory

Status reports and minimum reorder reports help to reduce the potential hazard of overstocking which results in cash flow problems. Program selection allows the user to store data for inventory located at up to five separate sites (divisions),

GENERAL ACCOUNTING SYSTEM For TRS-80™

S.B.S.G. has created the first completely user-configurable accounting system available for the TRS-80™.

User configurable? Each S.B.S.G. General Accounting System Module (except Order Entry) can be operated independently, or any of the modules can be combined in any configuration, providing a complete, coordinated system to fit the needs of your business.

The S.B.S.G. System allows you the maximum efficient use of available disk space. Each module will run on a standard 1 disk drive system (except for Model I systems, which require 2 drives). As you add more disk drives to your system, the amount of on-line data storage increases. Now here's an important fact . . . the S.B.S.G. General Accounting System "spans" your disk drives - that means that you can instantly access your data on any of **up to 8 disk drives** at any time! Since your S.B.S.G. Accounting System is user-configurable, it will work with 1, 2, 3, 4 or more disk drive systems - and it is fully compatible with most hard disk drive systems (at additional cost).

and more. All data is maintained and reported by month, quarter, year and previous three quarters. Transactions may be entered via direct posting and external posting generated by A/R, A/P, Payroll - or any other user source.

fication or deletion invoice and allows for progress payment. The transaction information includes: type of A/R transaction, P.O. #, description of P.O., billing date, general ledger sales account #, invoice amount, shipping and transportation charges, tax charges, payment, and progress payment information. Reports include: summary or detail listing of invoices not yet billed, open items (unpaid invoices), closed items (paid invoices), and aging. Statements may be printed at any time and follow the format of nationally available forms.

ordered, extension, taxable or not. It also allows the user to enter, display and correct invoice totals, noting the invoice subtotal, taxes, shipping and handling, with disbursement up to 5 General Ledger accounts; print a transaction report; maintain a terms code file in the system; update Account Receivable and generate summary report totals. It automatically coordinates to the Inventory Module (if used) to determine description, price and out of stock status, and to immediately deplete inventory stock. Price fields are easily modified to include percent or dollar discount

or even specific invoices. The reports include open item listings and closed item listings (both detail and summary), debit and credit memo listings, aging, check register report (to give an audit trail of checks printed), and vendor listing and vendor activity. Update reports are useful for audit trails and checking for accuracy. Checks may be printed at any time and follow the format of nationally available forms.

printing of reports and checks. State and Federal Tax changes are easily implemented by the user via menu prompting. In its link to General Ledger, each employee's payroll information is distributed to as many as 12 different GL accounts; system automatically posts to cash account.

coding up to 9 sales people. Available reports include inventory master list, price listings, period and year-to-date sales, stock status, minimum reorder point and commission information.

H & E COMPUTRONICS Gives A 30-Day Money Back Guarantee On All SBSG Product

Model I, 48K and 2 Disk Drives . . . \$195.00 Per Module
Model III, 48K \$195.00 Per Module

Model II, 64K \$295.00 Per Module
Sample Report Printouts \$ 10.00

DEALER INQUIRIES ONLY:

**SMALL
BUSINESS
SYSTEMS
GROUP**

6 CARLISLE ROAD
WESTFORD, MASS 01886 5762
(617) 692 3800

USER ORDERS:

COMPUTRONICS
MATHEMATICAL APPLIANCE SYSTEMS

50 N. PASCACK ROAD
SPRING VALLEY, NEW YORK 10977

*** ALL PRICES AND SPECIFICATIONS SUBJECT TO CHANGE ***

NEW TOLL-FREE
ORDER LINE
(OUTSIDE OF NY STATE)
(800) 431-2818

**24 HOUR
ORDER
LINE**
(914) 425-1535

ADD \$2.00 FOR SHIPPING IN U.S. AND AS
ADD \$8.00 FOR C.O.D. OR NON U.S. AM'S AS
ADD \$5.00 TO CANADA AND MEXICO
ADD PROPER POSTAGE OUTSIDE OF U.S.
CANADA AND MEXICO

COMMUNICATIONS SYSTEMS

Small Business Systems Group markets a complete line of software which interfaces the TRS-80™ with ANY computer that communicates in ASCII. This family of products offers both terminal and host capabilities to users with even the most minimal hardware configurations. There has been wide interest in these

ST80-III™ -- The Ultimate Communications System

The "state of the art" in communications processors, designed for complex commercial applications. Included in this package is a set of programs that allow your TRS-80™ to talk to a timesharing computer, transfer files to and from your central business computer, and customize your ST80-III to your specific application.

Features include: Selectable RS232 Setting • Help Display • Echo Feedback • Job Log (LDOS Mod I, Mod III) • 2-User Translation Tables • Auto Logon • 10 Function Keys (Definable) • RUBOUT Key (Definable) • Warm Restart • Automatic I.D. • True Break • Direct Cursor Addressing • DOS Command Support • Transmit Line Feed • Printer Support • Video Display Modes:

FORUM-80™ -- Communications Network

With Bill Abney's hot new communications product, you and your TRS-80™ can become part of one of the fastest growing communications networks in the country; your computer becomes an on-line bulletin board system: users can leave messages, get messages, swap information; exchange VisiCalc™ reports, charts, graphs or other correspondence with other computers

Features Include: Security System • Constantly displayed time in use figure •

ST-80-PBB™ -- Personal Bulletin Board

A small yet powerful bulletin board for the individual to gather and leave electronic mail. Messages reside in data base in memory, eliminating the problem of scanning magnetic media.

Features include: Password Security System • Four levels of Access—Guest, Member, Owner, Operator • User Log • Four message types • Smart reverse

ST-80-CC™ -- Communications Center

More than a personal bulletin board, this is a complete communications system for low to moderate traffic. Like ST80-PBB™ it supports four levels of users and four levels of messages with text editing and reverse scan of messages.

Additional Features include: Transmit same message to many individuals • Auto logon and multiple command scanning • Print messages on line printer.

MouseNet™ -- Advanced Bulletin Board System

Designed to accommodate high volume traffic, to operate simply enough for novice users, yet is fast and powerful enough for experienced callers

Features include: Messages stored on disk in keyed file • Uses machine language subroutines for speed • Supports text editing commands • Help commands guide user • System bulletins display each time a user logs on • All

DELUXE PERSONAL FINANCE For TRS-80™ Model II

This is a sophisticated and unique financial analysis package which can be readily customized to suit your personal financial situation. It will:

- Accept and apply transactions to user-formatted budget categories
- Separate cash and check disbursements.
- Allows up to ten category disbursements per check.
- Credit income/deposits according to source.
- Search, correct or void checks.

products from "comm buffs," the educational community, and **businesses and individuals who need to communicate on a regular basis.** Our systems are among the most versatile and comprehensive on the market today for TRS-80™ microcomputers.

SCROLL, FORMAT, PAGE, REVERSE VIDEO (Mod II), CURSOR ON/OFF • Auto-answer • Autodial (certain modems) • Append to memory buffer • Big buffer for printer • Off hook / on hook • 10 predefined ASCII strings in translation tables. • Registered users include NASA, USN, UPS, Westinghouse, and many colleges, universities and major banks.

Minimum Requirements: One disk drive, RS232-C, 32K Model I or III, 64K Model II.

Model I or III \$150.00
Model II \$250.00

User Friendly • User Configurable or can be modified for custom application • Future updates and upgrades available to register owners • Multiple command strings • Non-technical user and operator manuals.

Minimum Requirements: TRS-80™ (3-drive Mod I, 2-drive Mod III), 48K, RS232-C, Auto-answer modem.

Model I or III \$350.00

scan to view messages from most recent to oldest.

Minimum Requirements: TRS-80™ (Mod I or III), 16K, Level II, Auto-answer modem, ST80-X10 Host Program (\$50), RS232-C.

Model I or III \$50.00

save messages in memory buffer, maintain database without user intervention.

Minimum Requirements: TRS-80™ (Mod I or III), Level II, 48K, one disk, Auto-answer modem, ST80-X10 Host Program (\$50), RS232-C.

Model I or III \$100.00

messages are dated.

Minimum Requirements: TRS-80™ (Mod I or III), 48K, RS232-C, 3 Disks, Auto-answer modem, text editor (such as Scriptit)

Model I or III \$295.00

- Maintain an accurate checking account balance
- Cancel returned checks
- Provide monthly summaries of income vs. expenses.
- Calculate profit/loss.
- Summarize data by categories.
- Provides up to ten savings account summaries

Model II \$75.00

ACCESSIBILITY

We are here to serve your after-purchase needs. You can read our Monthly Newsletter containing current information about SBSG's products. Our Newsletter is free to our customers and is available at a minimal cost to anyone interested in Microcomputers or call SBSG directly for Programming and

Accounting Support. We have 8 incoming lines or call our COMM: Micronet Bulletin Board: ID # 70319236, FORUM-80™: (617) 692-3973, MouseNet™: (617) 692-8121; The Source: TCC 413.

✓ 9

H & E COMPUTRONICS Gives You A 30-Day Money Back Guarantee On All Modules

How one man solved his RFI problem.

LNW-80

Richard L. Brocaw
1850 Pearl Loop
Bosque Farms, NM 87068

I purchased my TRS-80 in 1978. Radio Shack's original design problems were compounded by my rural location. The RFI interference precluded its use in the ham shack.

It seemed obvious I needed a hardware upgrade. The replacement had to be software-compatible with the TRS-80. I shopped

around and decided on the LNW. I ordered both circuit boards.

The Processor Board

The circuit boards are silk screened and solder masked with plated-through holes. The processor board has a gold plated edge connector.

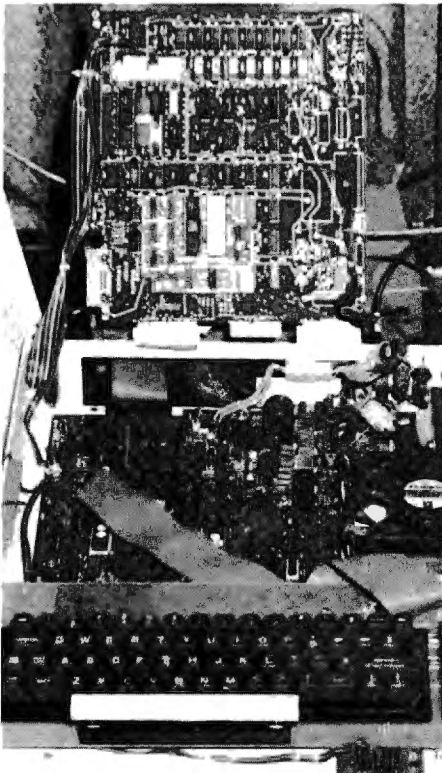

Two views of the interior of the LNW-80 built by the author. The expansion board has been lifted out and laid back to reveal the processor board. The power supply is on the right side, and the fan RFI filter and IC regulators with their heat sinks can be seen. Note the use of heavy wire to connect power to the expansion board. The expansion board shows the two piggyback boards: Percom Doubler and the programmable baud rate generator. The default RS-232 parameters are selected by switches seen at the lower right of the keyboard. The wires running off the picture on the left are remote vertical and horizontal position controls. The wire on the top right of the keyboard goes to the LED power light. The small toroids clustered around the power supply are used in place of jumpers to help reduce noise.

The Z80A processor chip runs at 4MHz. Most of the circuit design is a leap ahead of the TRS-80. The power supply has an off-board large filter capacitor. The design uses several IC regulators with overvoltage crowbars and fuses for protection. This circuitry is clustered in one section of the board to keep heat from sensitive circuits. Heat sinks are mandatory on the regulators.

"The LNW case is an attractive low profile cabinet made of heavy gauge steel . . ."

There are 90 ceramic and 18 tantalum capacitors on the board with only 0.1 volt of noise on the plus five line.

The memory design has Schmitt trigger devices on all lines; the address lines have series termination. The result is a quiet memory. 200 nS memories are required with the 4MHz clock.

The character generator ROM can be a custom programmed 2716 or the TRS-80 character generator. The new Radio Shack ROM with lowercase descenders also works.

For the language ROMs the two or three chip Radio Shack set or LNW six chip set will do. For the six chip set the ROMs are 2716s. The configuration is selected by a DIP switch of jumpers.

The processor speed is slowed to 1.77 MHz when the ROMs are accessed by inserting wait states in the Z80. When running the Basic interpreter, the speed increase over the TRS-80 is around 40 percent (depending on the application). When running machine language ROM independent software the LNW is more than twice the speed of the TRS-80.

The LNW-80 allows use of a Radio Shack keyboard or the LNW keyboard. There are two connectors on the circuit board. U30 and U34 must be removed to use the Radio Shack keyboard.

Graphics

The foremost feature of the LNW is the on-board inclusion of high density black and white and color graphics consisting of six additional 4116s with support circuitry. It is controlled by an OUT command to port 254.

The graphics pixels use the same address space as the Basic ROMs, activated by an OUT to port 254 with bit 3 set. The command deactivates Basic making a machine language driver necessary for graphics. This is fairly well documented in the manual. High and low resolution graphics and characters can be displayed at the same time.

The screen is divided into an inner and extended region. The inner region is 384 by 192 pixels. The extended region is another 96 pixels horizontally. Addressing for the two regions differs slightly.

For color graphics either a color monitor or a tv with on-board RFI modulator is used. Outputs for an RGB monitor can be wired in. There are two color modes. The first gives you 128 by 192 pixels in eight colors. The high resolution mode gives 384 by 192 pixels. The bandwidth for this mode requires

an RGB monitor. The color graphics requires a custom programmed 82S23 ROM, available from LNW. The ROM contents are detailed in the manual.

Drawbacks

LNW lists a 24 by 80 character video screen in its advertising. This is a little deceptive. The LNW-80 has the capability of a 24 by 80 screen by utilizing the high density graphics, but to get it you have to write a driver program.

LNW's six chip ROM set costs \$120. Considering that 2716s go for about \$6 each, I decided to program my own. But which address blocks go in which ROM socket? I called LNW and was told the information was proprietary! Some schematic study and experimenting revealed the truth as can be seen in Table 1.

The Expansion Board

The expansion board is of the same high quality as the printed circuit board, except the gold plating costs extra. (The plating is worth it.) It has the same good memory design and Schmitt trigger drivers. There are 43 ceramic and 12 tantalum bypassing capacitors.

The board also has a few drawbacks.

The printer port works okay if the printer is only a few feet from the port. You never want to hook a long line to the output of a D-type flip-flop. My printer is 20 feet away and 74LS175 will not drive it. I had to add buffering.

They cut corners on the RS-232 port. Wire jumpers select the default RS-232 parameters. Why not use a DIP switch? The baud rate is also a wire jumper, and is not software-selectable. You can change soldered jumpers about three times before the pads fall off or the plating pulls out. LNW should have added the one extra chip to make baud rates selectable. Or they could have laid out the DIP switch on the circuit board.

The RS-232 connector pads are spaced for a printed circuit mount right angle 25-pin con-

necter. Do not solder one on the board. When the board is in place inside the LNW cabinet there is no room to hook up to it with a plug. You also cannot use a straight connector. Besides, the connector pads are 16 inches from the nearest opening in the case. Use 25-wire extension cord.

The system expansion connector for outside devices is at right angles to the back of the case. You have to take the cover off to use it.

The Keyboard

Here is where the good designers at LNW went out to lunch en masse. The manual says the keyboard "is designed specifically for the LNW-80." The one I got was just a plain unencoded keyboard. A plastic bag with engraved keytops was included with instructions to replace certain keytops with the new ones. One of the new keytops was engraved sideways!

The key switches are the same wire finger switches that gave Radio Shack grief for so long. With this system, if you do not have a keyboard debounce fix, you will get keybounce in spades at 4MHz.

The circuit board is one-sided, with a large number of wire jumpers on top of the board. The keyboard has to sit on them and is difficult to seat for soldering.

Buy your keyboard someplace else. Radio Shack Model I keyboards are cheaper and superior.

The LNW case is an attractive low profile cabinet made of heavy gauge steel with room inside for both circuit boards, keyboard, power transformer, a muffin fan and RFI filter. Unfortunately it is overpriced. Build your own or buy a cabinet from Cramer.

Conclusion

The LNW-80 is, for the most part, a well designed, fast, effective computer. I use my LNW-80 with the Percom Doubler II and LDOS operating system. I have a time-of-day clock, plotter controller, music board and eight-bit general purpose port attached to my expansion bus. I designed and installed a piggyback board for selectable baud rates on the RS-232. All is working well.

Building an LNW-80 is not a project for a beginner. The manual is informative, but this is not a Heathkit. ■

Mr. Brocaw was born in Oklahoma in 1944. He holds a BSEE from New Mexico State University and is now a senior systems analyst for Public Service Co. of New Mexico.

IC Number	ROM Name (LNW Manual)	Address Decimal	Boundaries
			Hex
U75	A1	2-4K	0800-0FFF
U76	B1	6-8K	1800-1FFF
U77	C1	10-12K	2800-2FFF
U78	A	0-2K	0000-07FF
U79	B	4-6K	1000-17FF
U80	C	8-10K	2000-27FF

Table 1.

Color Computer word processing.

Telewriter

Telewriter
Cognitec
 704 Nob Ave.
 Del Mar, CA 92014
 \$49.95

Scott L. Norman
 8 Doris Road
 Framingham, MA 01701

With Telewriter, Color Computer word processing becomes a big-league affair. Telewriter offers full-screen editing with many of the cursor control features found in professional text-editing packages. It has most of the print formatting and cassette file handling features you might want, plus a few specialties of its own. Telewriter employs a software-defined character set to put 24 lines of 51 characters each on the video screen. That is a respectable fraction of a double-spaced text page and makes the full-screen editing meaningful.

Full-screen editing is one of Telewriter's outstanding features. You can move the cursor, which marks your location for text entry or deletion, anywhere over the displayed text. You can move it one space at a time, or whisk it along at high speed with the aid of control keys. You can also scroll the text in either direction. Finally, Telewriter does not distinguish between text entry, deletion, or editing modes. Type in your material and alter it as you go along if you like. You can see a significant amount of it at any time, so you get a good feel for how things are developing.

This free-wheeling operating mode coupled with the real lowercase character set (which looks like 5 by 7 matrix printing), lets you spend most of your energy on thinking and composing. There is relatively little need to be concerned with control keys and the computer until you format the material for printing. I was relatively relaxed about using Telewriter for the first time. That part of the command syntax with which I did have to become concerned at the outset seemed to come along very easily.

“With Telewriter, Color Computer word processing becomes a big-league affair.”

Telewriter is a machine-language program requiring a minimum of 16K of RAM; 32K are better in terms of text storage capability, since Telewriter itself occupies over 6,400 bytes. A 16K machine can store just over 2,200 characters, or less than two pages of average double-spaced text. With 32K you can store about 18,500 characters. Of course, you can record the contents of the text memory on tape and chain together as many cassette files as you like, so the effective capacity of either hardware configuration is unlimited.

Getting Started

The program is supplied on cassette, recorded once on each side. The labeled side also contains a text file for demonstration purposes. The documentation is quite complete and takes the form of two manuals: a 27-page tutorial, which leads you by the hand through most of the program's features, and a 33-page reference manual, which treats the various commands in more detail. An additional sheet summarizing the commands is also furnished, and it makes a handy user's guide once you become familiar with Telewriter's operation.

There are two menus: main and format. The main menu comes up when you load the program and give the EXEC command, and is used to read or save a cassette file, create or edit text in RAM, and perform a few other chores. The format menu, which you access by entering the F command, controls the printing format and in-

structs the computer regarding the number of files to be chain printed. You can also embed many of the format menu's commands in your text in order to change such parameters as line spacings, margins, and printing fonts on the fly. Menus are displayed in standard reverse video, and most commands require only a single-letter response (i.e., you do not have to press Enter). Where additional input such as a numerical value for setting a printing parameter is required, the familiar flashing Basic cursor appears at the appropriate spot on the format menu.

You begin to enter text by giving the main menu's C (Create) command. The display switches to a white screen with a flashing L for a cursor and a small black rectangle for an end-of-text marker. Anything you enter at this point will be in Telewriter's software-defined font. The usual shift-0 combination is retained for uppercase lock. You can move the cursor anywhere over the text by means of the Color Computer's four arrow keys, used by themselves or in combination with either shift or Clear. The shift gives any arrow key a fast auto-repeat, while Clear is a special control key. With it, you can make the cursor skip to the top or bottom of a text file using the up or down arrows, or to the beginning or end of a given screen line with the horizontal arrows.

Clear lets you define other keystrokes as commands, rather than text, in this mode. For example, Clear-P scrolls the display forward by one full screen. This lets you enjoy the flexibility of full-screen editing.

If you place the cursor somewhere in the middle of a block of text and begin to type, the new material is added to the old; you do not type over anything. In the same way, backspacing over text does not erase it. The Break key alone erases the character immediately to the right of the cursor, while the Clear-Break combination erases the character to the cursor's left. There are also simple methods for erasing complete lines or large blocks of text. To erase an arbitrary chunk of material, position the cursor at the end of the unwanted section and type Clear-E. This generates a heavy right

ALCOR PASCAL

AT LAST

A COMPLETE PROFESSIONAL QUALITY PASCAL FOR THE TRS80

Pascal Features

1. A complete Jensen and Wirth Standard Pascal
2. Produces compact efficient code that executes 10-20 times faster than interpreted BASIC
3. Generates reentrant Romable code
4. Can compile large programs (4000 lines +)
5. Fast one pass compiler
6. Simple commands for compiling and running programs
7. Supports separate compilation of procedures and functions
8. Compiler switch options, including conditional compilation
9. Full heap support including NEW and DISPOSE procedures that perform true heap allocation
10. Complete implementation of sets with up to 256 members. All standard set operators
11. Variant records are fully supported
12. Supports single and double precision REAL
13. Files are compatible with TRSDOS

Extensions

14. OTHERWISE clause on case statements
15. Identifiers may contain '\$' and '-' characters
16. Automatic type conversion in arithmetic expressions and assignment statements
17. Constants may be expressed in decimal or hexadecimal
18. Characters within strings may be specified by ascii code. Allows non-printable characters in strings.
19. Type transfer operator to override type matching requirements
20. ESCAPE allows exit from anywhere in a procedure
21. LOCATION function returns the address of a variable
22. SIZE function returns the amount of memory required for a variable

TRS-80 Library

23. Graphics routines (setpoint, cleargraphics ...)
24. Interface to assembly language routines with parameter passing
 - Can call operating system and ROM routines
 - Memory may be protected from Pascal for use by assembly language routines.
25. Read keyboard (scan or wait for character)
26. Write to CRT screen with cursor addressing
27. Direct access to memory with PEEK and POKE
28. Input and output to IO ports from pascal
29. Programs may perform their own recovery from file and device errors
30. File or device names for Pascal files are determined from the keyboard when a program is executed. Alternatively a program may internally specify file names.

Full Screen Text Editor

31. Included with Pascal or available separately
32. No limit on file size (except disk capacity)
33. Full cursor movement and scrolling
34. Insert and delete characters
35. Insert, delete, duplicate, split, merge lines
36. Find string, replace string
37. Typewriter style tabs and autoindent
38. Show file, Insert file
39. Horizontal scrolling allows editing of files containing lines wider than the screen
40. Key and command mode access to commands
41. On-line documentation with HELP command
42. Files are compatible with TRSDOS
43. Can also edit text and BASIC programs
44. Many additional features

The Best of Both Worlds

45. Pseudocode (Pcode) for compactness
 - Allows large programs in small memory space (8500 line + programs can execute in 48k)
46. Native code for speed
 - Optional code generator produces Z80 instructions
 - Z80 code can be mixed with Pcode

Linking Loader

47. Links separately compiled routines
48. Supports procedure and function libraries
49. Can create command files that are callable as commands from TRSDOS top level

250 Page Documentation Package

50. Beginner's guide
51. Pascal Tutorial with 500 line Data Base program. (source supplied on diskette)
52. Pascal Reference Manual
53. System Implementation Manual
54. Text Editor Manual
55. Handy System Reference Card
56. Cross reference index for documentation package

Optional Advanced Development Package

57. Pcode optimizer
 - Reduces the size of a program by 25-30%
 - Increases execution speed
58. Z80 native code generator
 - Produces relocatable, reentrant native code for the Z80
 - Native code executes 3-5 times faster than Pcode.
 - Native code can be mixed with Pcode to provide speed where required and still benefit from the compactness of Pcode

Hardware Required

TRS-80 model I; TRS-80 model III; or CP/M system (with Z80)
48k of memory
One disk drive (two recommended)

TRS-80 version compatible with TRSDOS and most other operating systems.

Available directly or through authorized dealers.

COMING SOON

Alcor Pascal for:

Zenith Z89, IBM Personal Computer, 8086 and 68000 based systems

Yes, I'm interested in Pascal for:

- TRS-80 Model I
- TRS-80 Model III
- CP/M (available March 1, 1982)
- Send More Information
- Alcor Pascal System
- Text Editor only
- Advanced Development Package
- Manuals only



free
\$199
\$ 60
\$125
\$ 30

Name _____

Address _____

City _____ State _____ Zip _____

Send to: **ALCOR SYSTEMS**
13534 Preston Road
Suite 365
Dallas, Texas 75240
For immediate service call.
(214) 226-4476

ALCOR

TRS-80 is a trademark of Tandy Corporation
CP/M is a trademark of Digital Research, Inc.
Z80 is a trademark of Zilog, Inc.
IBM is a trademark of International Business Machines
Z89 is a trademark of Zenith data systems

"To save you from yourself Telewriter requests confirmation before executing any command."

bracket on the screen. Then move the cursor to the beginning of the section and type Clear-X. Telewriter deletes the material and reformats the display to eliminate gaps.

Telewriter has many other commands for moving and changing text, and most of them use Clear to define a control function in a similar way.

To find a text pattern, move the cursor to the top of the text file and enter Clear-F. The standard Basic text screen returns, and you enter the pattern for which you want to search (lowercase is now in reverse video). Press Enter to return to the Telewriter text screen. The cursor flashes at the first location of your search pattern. You can find the next occurrence, and all subsequent occurrences, by entering Clear-N. Global (selective) search, change or delete are possible with the Clear-G command. You again enter the search pattern, but now the Enter key keeps the Basic screen and drops the cursor one line. This time, you enter the pattern which replaces the one sought; it need not change at every occurrence. Pressing Enter a second time returns you to the text file, with the cursor flashing as in the find

operation.

If you want to change to the new pattern just specified, press Clear-R; if not, press Clear-N to skip to the next occurrence of the target. You can extend this to a selective deletion of text; instead of a replacement pattern, enter a second carriage return.

To copy a block of text, mark the end of the block by pressing Clear-N as for deletion, then mark the beginning by pressing Clear-B, which generates a heavy bracket. Move the cursor to the place where you want the copy to begin, and press Clear-C. Telewriter copies the block and rewrites the screen. The original block is left in place, with the brackets deleted. If you want to move the block instead of copying it, you must delete the original as described above.

Pressing Clear-A fills out broken text lines (necessary if you hit Enter after every sentence). You can preserve paragraph beginnings by indentation or by using an additional Enter.

The Cassette Handler

You access all of the text-manipulation commands discussed so far from the editor portion of the main menu. Another section, called the cassette handler, provides the means for storing and retrieving text. Its commands allow you to read a cassette file into memory, append a text file from tape to the end of any file in RAM, write all or part of a file from RAM to tape, and verify that such writing was successful.

Cassette Handler commands consist of a single letter (or the percent sign, in the case of partial save). Each results in the appearance of the Basic's flashing block cursor next to the selected command as the program awaits a file name. You can skip the file name in all cases, but it is a poor idea to write an unnamed file to tape. The procedure for saving a portion of a file requires you to first go into the editor and mark the end of the desired portion by pressing Clear-E. You then move the cursor to the beginning of the segment as though you were deleting it, return to the main menu with Clear-M, and enter the % command.

The Verify command is extremely useful. Until quite recently I was using a 16K computer, so I had to chain print many files for anything much longer than a letter. Nothing is quite as discouraging as an "I/O ERROR" message in the middle of one of these chaining operations. Verify allows you to check a tape record to make certain that it can be read properly, all without destroying the text file in memory. Should a read error occur, you can rewrite the file to tape. Press Break first to abort the error condition and return to the main menu.

To save you from yourself, Telewriter requests confirmation before executing any command, such as Create or Read In, which can destroy material in memory. The request takes the form of the message "SURE???" next to the command involved on the menu. The only acceptable answers are an uppercase Y or any word beginning with one.

There is one more especially handy main menu command. Clear-W displays the number of words in the text buffer, along with a count of the number of lines into which the text is formatted at any particular time. It also tells you how many spaces (characters or carriage returns) are still available. The part of the menu that displays this information also gives the name of the last file read or appended from cassette. This helps you keep track of your file names when you are chaining many together for printing.

Formatting and Text Printing

As I noted earlier, the main menu's F command brings up the format menu. This displays the defaults for the basic format parameters: line spacing and length; the left, top, and bottom margins; number of lines per page; and the baud rate (encoded according to a table in the documentation). You can reset any of them, and also specify several others: the starting page number of the file in memory, the number of files to be chain printed, and whether or not the printer is to pause at the bottom of each page. There is a special Font command for MX-80 users as well.

The format parameters only have to be set once if you are chain printing several files. If you desire page numbers, make the appropriate non-zero entry for the starting page of the first file. Telewriter keeps track of the line count and the page number across file boundaries during printing.

Good word-processing programs include embedded commands which you can incorporate in the text in order to change formats. Telewriter's are defined by a special leading character—an upward-pointing caret—which you generate by pressing Clear and then the period. You can use everything mentioned so far, except for the MX-80 font and the number of files in the printing queue, in an embedded command.

The embedded commands have their own syntax rules. They must appear on lines containing only commands—no text. The program recognizes the control caret only if it is indented by at least one space from the left margin. Several embedded commands can appear on one line, in general, provided that they are separated by at least one space. There is no hierarchy or preferred order to the commands.

Electronic Circuit Analysis

- Detailed analog circuit analysis
- DC and AC analysis
- Very fast, machine language
- Infinite circuits on multiple passes
- Worst case analysis
- Dynamic modification
- 64 Nodes
- Compare circuits
- Log or linear sweep
- Full file handling
- Frequency response, magnitude and phase
- Complete manual with examples
- A truly professional program with features previously available only on large systems
- TRS-80 model I or model III, disk \$75.00
- Also available: "The Mini-Circuit" \$19.95 cassette for Hobbyists and students

Tatum Labs
P.O. Box 722
Hawleyville, CT 06440
(203) 426-2184

TRS-80 is a trademark of Tandy Corp.

✓ 263

MULTI-USER OASIS HAS THE FEATURES PROS DEMAND. READ WHY.

Computer experts (the pros) usually have big computer experience. That's why when they shop system software for Z80 micros, they look for the big system features they're used to. And that's why they like Multi-User OASIS. You will too.

DATA INTEGRITY: FILE & AUTOMATIC RECORD LOCKING

The biggest challenge for any multi-user system is co-ordinating requests from several users to change the same record at the same time.

Without proper co-ordination, the confusion and problems of inaccurate or even destroyed data can be staggering.

Our File and Automatic Record Locking features solve these problems.

For example; normally all users can view a particular record at the same time. But, if that record is being updated by one user, automatic record locking will deny all other users access to the record until the up-date is completed. So records are always accurate, up-to-date and integrity is assured.

Pros demand file & automatic record locking. OASIS has it.

SYSTEM SECURITY: LOGON, PASSWORD & USER ACCOUNTING

Controlling who gets on your system and what they do once they're on it is the essence of system security.

(THEN COMPARE.)

Without this control, unauthorized users could access your programs and data and do what they like. A frightening prospect isn't it?

And multi-users can multiply the problem.

But with the Logon, Password and Privilege Level features of Multi-User OASIS, a system manager can specify for each user which programs and files may be accessed—and for what purpose.

Security is further enhanced by User Accounting—a feature that lets you keep a history of which user has been logged on, when and for how long.

Pros insist on these security features. OASIS has them.

EFFICIENCY: RE-ENTRANT BASIC

A multi-user system is often not even practical on computers limited to 64K memory.

OASIS Re-entrant BASIC makes it practical. How?

Because all users use a single run-time BASIC module, to execute their compiled programs, less

memory is needed. Even if you have more than 64K, your pay-off is cost saving and more efficient use of all the memory you have available—because it services more users.

Sound like a pro feature? It is. And OASIS has it.

AND LOTS MORE...

Multi-User OASIS supports as many as 16 terminals and can run in as little as 56K memory. Or, with bank switching, as much as 784K.

Multi-Tasking lets each user run more than one job at the same time.

And there's our BASIC—a compiler, interpreter and debugger all in one. An OASIS exclusive.

Still more: Editor; Hard & Floppy Disk Support; Keyed (ISAM), Direct & Sequential Files; Mail-Box; Scheduler; Spooler; all from OASIS.

Our documentation is recognized as some of the best, most extensive, in the industry. And, of course, there's plenty of application software.

Put it all together and it's easy to see why the real pros like OASIS. Join them. Send your order today.

OASIS IS AVAILABLE FOR SYSTEMS: Altos, CompuCorp, Cromemco, Delta Products, Digital Group, Digital Microsystems, Dynabyte, Godbout, Index, Intersystems, North Star, Onyx, SD Systems, TRS 80 Model V, Vector Graphic, Voronius.

CONTROLLERS: Bell Controls, Camtec, Corvus, Kongs, Microtron, Microvax, Parbell, Telebit, Linkertec, etc.

Write for complete Price Application Software Directory

PLEASE SEND ME:

Product	Price with Manual	Manual Only
OPERATING SYSTEM (Includes EXEC Language, File Management, User Accounting, Device Drivers, Print Spooler, General Text Editor, etc.) SINGLE-USER MULTI-USER	\$150 350	\$17.50 17.50
BASIC COMPILER/INTERPRETER/DEBUGGER	100	15.00
RE-ENTRANT BASIC COMPILER/INTERPRETER/DEBUGGER	150	15.00
DEVELOPMENT PACKAGE (Macro Assembler, Linkage Editor, Debugger)	150	25.00
TEXT EDITOR & SCRIPT PROCESSOR	150	15.00
DIAGNOSTIC & CONVERSION UTILITIES (Memory Test, Assembly Language, Converter, File Recovery, Disk Test, File Copy from other OS, etc.)	100	15.00
COMMUNICATIONS PACKAGE (Terminal Emulator, File Send & Receive)	100	15.00
PACKAGE PRICE (All of Above) SINGLE-USER MULTI-USER	500 850	60.00 60.00
FILE SORT	100	15.00
COBOL-ANSI '74	750	35.00

Order OASIS from:
Phase One Systems, Inc.
7700 Edgewater Drive, Suite 830
Oakland, CA 94621

Telephone (415) 562-8085
TWX 910-366-7*39

NAME _____
STREET (NO BOX #) _____
CITY _____
STATE _____ ZIP _____
AMOUNT \$ _____
(Attach system description; add \$3 for shipping; California residents add sales tax)
 Check enclosed VISA
 UPS C.O.D. Mastercharge
Card Number _____
Expiration Date _____
Signature _____

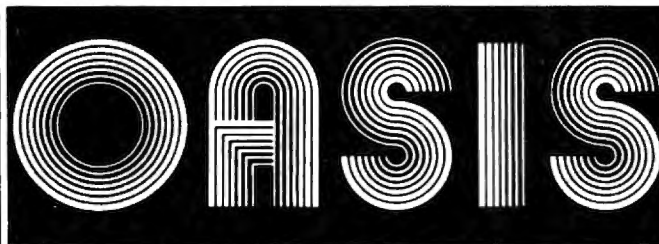

MAKES MICROS RUN LIKE MINIS

"One of Telewriter's very few bugs occurs when you use headers."

Let's say you are printing with double spacing, a left margin of 10 spaces, and a line length of 60 characters, and you want to highlight a quotation. You might do so by switching to single spacing and indenting another 10 spaces at both right and left margins. You would embed the following command line: M20 C40 S1. Notice that the margin is set first, then the number of characters in the line, then the line spacing. Finish the command line with a carriage return, and enter the quotation. When you are finished, you can revert to the original format with, say, this command line: S2 C60 M10 where I have changed the order at random. It is easier to keep track of things if you set and reset parameters in the same order, but it is not mandatory.

A few print commands which do not control standard format parameters also use the embedded command syntax. You can center a title by prefixing it with a caret and an asterisk. You can print a header at the top of every page of a file but the first, using the H format code. One of Telewriter's very few bugs occurs when you use headers.

The Header command is required at the beginning of every file chained in a printout. A caret precedes and follows it. It has the syntax HN...Header where N is the number of blank lines desired between the header and the body of the text, and where the dots represent the blanks needed to properly indent the header itself. The usual margin format does not apply. The Telewriter reference manual recommends that you follow embedded commands with a second carriage return before beginning text entry. This generates a blank line which is not printed but which keeps the Align feature (Clear-A) from combining the text with the command and destroying the format. (The header would not be printed as part of a text line, but its length would be counted in formatting.) Unfortunately, I found that if a header definition is followed by two carriage returns, it fails to print at the top of the second page; it does not begin until the third. This is not an earth-shaking problem, but I found it annoying because much of my writing consists of material for publication, and identifying headers are required.

There are two solutions. You can print the header at the top of the second page if you follow it by only one carriage return, but then you must find another way to keep a subsequent align from combining it with the text. An indentation as well as an extra carriage return signal the start of a paragraph. All you have to do then is standardize on indentation for paragraphs.

Howard Cohen of Cognitec found the second solution, which is to load the first of a series of chained files into memory before defining its header, and start printing from that configuration. On the format menu, set the number of files in the queue to one less than the total number of files.

This bug has now been eliminated, but Telewriter purchasers should check out their own copies of the program.

You can also use the embedded command concept to define special control codes. With the Caret-D command you can define up to nine special characters of up to 15 numbers, each number being an ASCII code for either a printing or a non-printing character. You use this method to change

COMPUTER KITS - FROM \$69.95

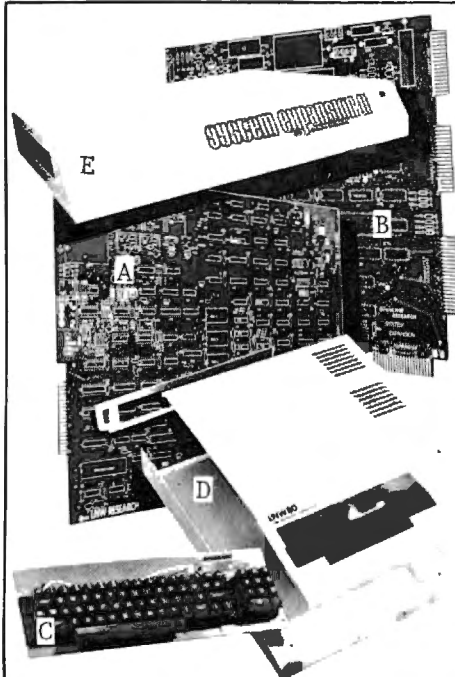

LNW SEMI-KITS can save you hundreds of dollars. By obtaining your own parts at the lowest possible cost and assembling the **LNW SEMI-KITS**, you can have the most highly acclaimed microcomputer in the industry - the **LNW80**. The **LNW SEMI-KITS** are affordable modules. You can start with a modest cassette system and expand to a full 4Mhz TRS-80 compatible system with 5 or 8 inch double density disks and color at any time.

A. LNW80 CPU - Made of high quality FR4 glass epoxy double sided circuit material, with plated-through holes and gold edge connector. It is fully solder-masked and silk screened. Here are just some of the outstanding features you will have when your **LNW80 CPU** board is fully assembled:
 • 16K RAM • Color and black and white video • 480 x 192 high resolution graphics • 64 and 80 column video • 4 Mhz Z80A CPU • Upper and lower case display • 500 and 1000 baud cassette I/O - \$89.95

B. SYSTEM EXPANSION - Expand the **LNW80** computer board, **TRS-80** and **PMC-80** computer with the following features: • 32K memory • Serial RS232C and 20Ma port • Real time clock • Parallel printer port • 5 inch single density disk controller • Expansion bus (screen printer port) • Onboard power supply • Solder-masked and silk screened legend - \$69.95 (tin plated contacts) - \$84.95 (gold plated contacts)

C. KEYBOARD - 74 key expanded professional keyboard - includes 12 key numeric keypad. Fully assembled and tested - \$99.95

D. COMPUTER CASE - This stylish instrument-quality solid steel case and hardware kit gives your **LNW80** that professional factory-built appearance. - \$84.95 Add \$12.00 for shipping

E. SYSTEM EXPANSION CASE - This stylish instrument-quality solid steel case and hardware kit gives your **SYSTEM EXPANSION** interface that professional factory-built appearance. - \$59.95 Add \$10.00 for shipping

F. LNW80 CPU - HARD TO FIND PARTS KIT - \$82.00

G. LNW80 VIDEO - HARD TO FIND PARTS KIT - \$31.00

H. SYSTEM EXPANSION - HARD TO FIND PARTS KIT - \$27.50

I. LEVEL II ROM set (6 chip set) - \$120.00

VISA and **MasterCard** accepted. Add \$3.00 for shipping plus \$1.00 for each additional item. All shipments via UPS surface Add \$2.00 for U.S. Mail. Shipments outside continental U.S. funds must be U.S. dollars. Sufficient shipping costs must be included with payment.

ORDERS & INFORMATION - (714) 544-5744
SERVICE - (714) 641-8850

LNW Research Corp.

2620 WALNUT Tustin, CA. 92680

✓ 33

"I feel that the combination of full screen editing and the very respectable font give the program real advantages."

fonts for highlighting, for instance. Finally, you can use the control caret to align individual partial lines of text with the left margin by setting up each line as though it were a legitimate embedded command: indent one space, caret, text. Because these lines look like commands with incorrect syntax, Telewriter prints them. But because they are (apparently) commands, Telewriter ignores the leading space and the caret. Although this sounds bizarre, it works well in practice.

How it Works

While Telewriter may lack some of the features of word processors designed to run on larger, business-oriented machines, it gives the Color Computer respectability as a document preparation center for the home or school. I feel that the combination of full-screen editing and the very respectable font give the program real advantages. I have also used C.C. Writer for some time. I found it easy to learn to use, thanks to an excellent manual, but its line orientation and multiple modes for text entry and

editing can give the writer a real workout. Telewriter gives me a much better sense of control.

Improvements

Telewriter is not perfect. Several items remain on my wish list though none of these are crippling (or even serious) deficiencies.

Telewriter cannot right justify text. Although I use this feature only for correspondence (at least with C.C. Writer, where it is slow), it is still nice to have. Telewriter does not allow me to predefine tab stops. Telewriter has tabs every eight positions; the tab key is the Clear-Enter combination. You cannot reset the tabs, however, and eight spaces is just too far to indent a paragraph. Punching the spacebar five times is primitive compared with everything else in the program.

As far as text manipulation is concerned, I have occasionally wished for a block-move command that would automatically delete the block in its old location, rather than requiring me to go back and delete it after copying.

The Color Computer still lacks a word processor with a file-merging capability. It is not yet possible to write a letter with variable data in the address and salutation fields and merge it with a mailing list, for example. This is completely standard for business systems, and it would be extremely valuable in the home, as well. The applications to organizational correspondence are obvious. Perhaps Howard Cohen at Cognittec, or Bill Dye at Transformation Technologies, or someone at Computerware, Nelson Software, or even Tandy will include this feature in some future disk-oriented program.

None of these missing features keep Telewriter from being a fine program. The manuals cover several tricks that I cannot easily describe in a brief review, but which greatly enhance the power of the package. The program is easy to bring up for simple work the first time, but there is nothing like working with it for a while to bring out its real power. At \$49.95 it is the most expensive of the Color Computer word processors; it is worth it. ■

The Atlanta Computer Festival

June 12 - 13, 1982

Downtown Atlanta Marriott Hotel

- Held in conjunction with the famous Atlanta Ham Festival!
- 140 exhibitor booths devoted to Ham Radio and Microcomputing!
- Door Prizes include a TRS-80 Model III!
- Multi-level covered Fleamarket/Swapshop!
- Forums & meetings on a variety of topics!
- Parking for thousands of cars with complimentary shuttle bus to/from the Atlanta Civic Center lot!

Registration: \$5 per person at the door

DON'T MISS THIS OPPORTUNITY!

WRITE FOR BOOTH INFORMATION TO: P.O. BOX 27553, ATLANTA, GA 30327

HARDWARE BREAKTHROUGH

DESIGN SOLUTION inc. presents the AN-SERIES DEVELOPMENT SYSTEM for TRS-80™, Apple II™, Commodore PET™, Superbrain™*



\$179.95

DSI AN-7000 COMPUTER

True TRS-80™ work-a-like capability is now available in kit form from DSI. The AN-7000 provides a full 16K of dynamic ram, with a complete modulated video interface system for use with standard televisions, Z-80B Micro-processor, cassette interface, membrane keyboard, finished case and power supply module, as well as every component needed for ROM-less assembly. Save hundreds of dollars by assembling the AN-7000 processor yourself with only common hand tools. Step by step in-

structions with clear cut pictorials and schematics create a very straight-forward work environment as you assemble your own system from scratch. Totally flexible, the AN-7000 will interface with all Model I Level II hardware accessories including the DSI AN-760 FDC and AN-1000 Megadrives. The AN-7000 system represents the most significant break-through in user assembled computer equipment available. The AN-7000 kit comes complete with all parts necessary for a full 16K, Z-80 based CPU, less the 12K basic interpreter ROMS.

New DOS 80™ ver 2.0 is available at special package purchase rates for the AN-760 and AN-1000. Contact DSI for complete DOS pricing.

A Registered Microsoft™ TRS-80 Level II work-a-like 3 chip set with manual and complete documentation is available for the AN-7000. The Microsoft-DSI basic package lists at \$89.95.



DSI MEGADRIVE

\$590.00



This single or double density 80 track dual sides 5¼" floppy disk drive is a must for all serious TRS-80 and DSI systems users. With almost 1 million bytes of unformatted data storage capacity in the MFM double density mode the AN-1000 provides the utmost in stability of performance at a very reasonable price. Track to track access time 3 ms, soft error rate 1-10⁹ reads, hard errors 1-10¹² reads, and media life 4x10⁶, clearly represent the AN-1000 technology. Complete with power supply, case, cable and operation manual.

All connections made to AN-SERIES products from your bread-board are simply pushed through the front panel. Custom connectors on the P.C.B. provide super reliable connection for thousands of operations. All AN-SERIES products are warranted for a full 90-DAYS under DSI's limited warranty policy. Complete documen-

tation is provided for each model in an attractive folder, including theory of operation, and special interest projects and applications. All units are supplied with external power supply modules that connect through a mini-jack on the front panel.

DESIGN SOLUTION inc.
BOX 1225, FAYETTEVILLE, AR 72701

C.O.D. add \$5.00 — Other add \$3.00 S/H.
(Exports slightly higher)

Orders and Information: (501) 521-0281

HARDWARE BREAKTHROUGH

DESIGN SOLUTION INC. presents the AN-SERIES DEVELOPMENT SYSTEM for TRS-80™, Apple II™, Commodore PET™, Superbrain™*

\$99⁹⁵

DISK CONTROLLER

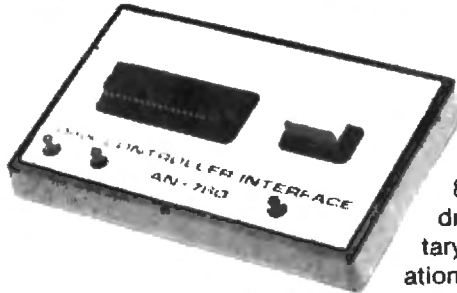

An affordable multidrive floppy disk interface. The AN-760 supports 35, 40, 80 and 160 track drives. Using proprietary Digital Data Separation Techniques, maxi-

mum permissible data transfer integrity is assured. Read, write, and step LED indicators prompt operator during all disk I/O. The AN-760 comes complete with power supply module and operation manual. (Operating system software optional.)

\$129⁹⁵ **DOUBLE DENSITY CONVERTER**

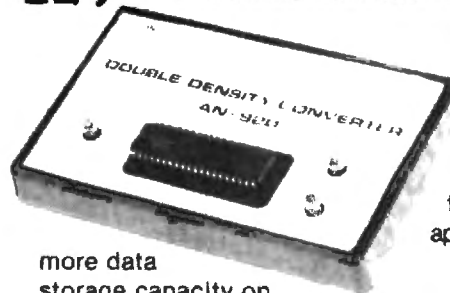

Using DSI Proprietary Data Separation and Write Precompensation Techniques, the AN-920 provides approximately 1.6 times

more data storage capacity on your 5¼ disk drives. The AN-920 can be used in conjunction with the AN-760 FDC or the TRS-80 expansion interface. Double Density System comes complete with power supply module and operation manual. (Required Newdos-80 Ver 2.0 Disk Operation System Optional.)

\$84⁹⁵

8K FIRMWARE INTERFACE

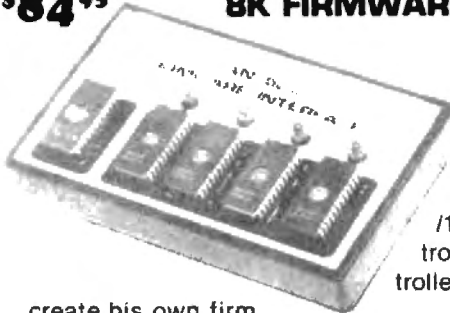

8K Bytes of User Programmable Firmware (4-2716 Eproms) are automatically loaded by system /12345 Command controlled by a 2716 controller chip. The user can

create his own firm operating system to load and execute programs from Eprom or to provide user defined arithmetic functions. Comes complete with power supply, operation manual and controller chip. (The AN-522 requires AN-551 Eprom programmer.)

\$99⁹⁵ **MULTI-RANGE DVM INTERFACE**

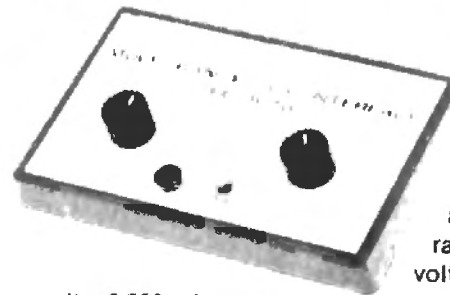

Analog Signal Interface is now as easy as turning a knob. EE-1670 provides DVM functions volts, and milli-amps and 8 ranges, 1-200 millivolts, 0-2, 0-20, 0-200

volts, 0-200 micro amps, 0-2, 0-20, 0-200 milliamps, standard banana jacks and test leads create perfect connection scheme for real time analog data acquisition. EE-1670 system is complete with power supply and manual of operation.

\$99⁹⁵

EPROM PROGRAMMER

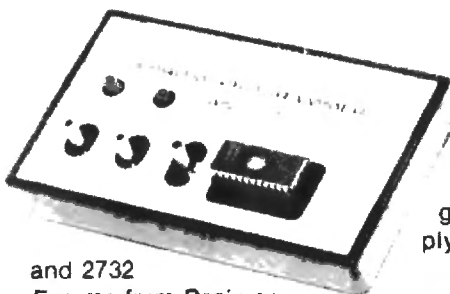

An enhanced version of our original Eprom Programmer, the AN-551 will now program the single supply 2516, 2716, 2532

and 2732 Eproms from Basic or machine language. Software provided will load Eprom from TRS-80 Ram or load TRS-80 Ram from Eprom with complete on-screen verification. The AN-551 comes complete with power supply and operation manual.

\$89⁹⁵

RS-232 INTERFACE

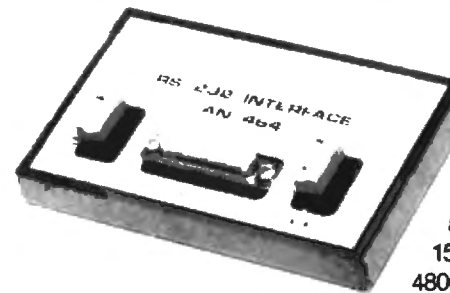

Can be configured to communicate with data communications equipment or data terminal equipment at 110, 150, 300, 600, 1200, 2400, 4800 and 9600 Baud. The

AN-464 provides 20MA loop output and RS-232C through a DB-25P connector. Software selectable odd/even parity, 5-8 bit word lengths and stop bit formats are standard along with power supply module, software driver, and operation manual.

All connections made to AN-SERIES products from your breadboard are simply pushed through the front panel. Custom connectors on the P.C.B. provide super reliable connection for thousands of operations. All AN-SERIES products are warranted for a full 90-DAYS under DSI's limited warranty policy. Complete documenten-

ation is provided for each model in an attractive folder, including theory of operation, and special interest projects and applications. All units are supplied with external power supply modules that connect through a mini-jack on the front panel.

DESIGN SOLUTION INC.
BOX 1225, FAYETTEVILLE, AR 72701

C.O.D. add \$5.00 — Other add \$3.00 S/H.
(Exports slightly higher)

Orders and Information: (501) 521-0281

Snapp V Extended (disk) File Mapping Support.

Snappware Eases Random Access

Snapp V Extended File Mapping Support Snappware
3719 Mantell Ave.
Cincinnati, OH 45236
\$75 Model II
\$60 Model III

Rick Lederman
TACAMS Inc
3375 Airport Hwy
Toledo, OH 43609

The Model II computer with Radio Shack Basic and TRS-DOS 2.0 seems to be the best computer buy, and probably the most powerful combination on the market. But even though Radio Shack Basic is extremely powerful, it retains many of early Basic's inherent problems.

Radio Shack Basic makes it difficult to use and program random or direct files. If you have not used random (direct) files yet due to their complexity, Snapp Inc. has made them so simple that any programmer can use them.

The statements and functions that Radio Shack Basic presently uses for random file manipulation are carry-overs from earlier versions of Basic. These functions (Field, LSET, RSET, MKI\$, CVI, and so on) use too much program space and create confusion.

Snapp Inc. uses the new verb SCMD (Snapp Command) to im-

plement their version of the Get and Put statements. These eliminate the need for LSET, RSET, MKI\$ and CVI.

Random File Manipulation

If you are unfamiliar with the statements used to manipulate random files, here is a short explanation. See Program Listing 1 for line number references. Line 100 opens a disk file named STOREQUI. It creates the file if none existed before. Buffer one passes information to and from the file. Each record is 25 bytes long. Line 110 divides the 25-character buffer into portions that are named by the Field statement. Line 130 places record number K% from the disk file into the buffer in memory.

Note that all numeric data in a direct file is stored in a compressed format, so after you retrieve the data from the disk with the Get command you must convert it to the proper type (integer, single or double precision) using the commands CVI, CVS or CVD. Line 140 assigns the integer variable WE% the integer value of ST\$ after converting ST\$ by the command CVI(ST\$).

Now refer to Program Listing 3. When placing data into a direct file, you open and field the file as before. Line 160 converts the integer WE% to a compacted string form with MKI\$

(make integer string) and then places it into buffer 1. The Field statement in line 150 places the converted WE% into the first two bytes of the buffer in memory, names these bytes ST\$ and places the bytes into the buffer from left to right (LSET).

Programmers often use random files where they require some sort of disk file system and do not need to read all of the file's information each time they access the file. I use random files to store 60 different aircraft load configurations which consist of a load-weight integer, four integers that represent the load size, shape and aerodynamic drag, plus a 15-character string description of the load. I store this information in records 1-60 and refer to them by their record number. As an example, if the operator needed the load information from record number 10, he need only enter 10 to the request "Enter Load Code."

The interpreter then immediately accesses the information in record 10 without having to read records 1-9. This saves time and wear on the disk drive.

To do the preceding (Listing 1), first open the file (line 100). Then field its buffer (line 110). Be sure the operator does not exceed the end of file (line 120). Then you must get the proper record and convert all data to the proper type (lines 130-160).

That portion of the software is a little complex, but not as complex as when you have to place information into a random file. To do that, first open and field the file (Listing 3, lines 140-150). Then convert all numeric data types like integer, single and double precision to strings using MKI\$, MKS\$ and MKD\$. Then LSET or RSET your variables into the variable names you used in the Field statement (lines 160-190). Put the data that is now in the buffer memory, which puts it into the file on your disk.

The Snapp Way

Program Listing 2 does the same thing as Listing 1, but uses Snapp V.

Rather than using Basic's conversion statements and Field, you need only give the proper SCMD and your variable names that appear in your program. The variable names may even appear in string form (lines 95 and 120); Extended File Mapping Support takes care of the rest.

Listing 3 puts data into the file named STOREQUI, and uses standard Radio Shack Basic. Lines 150-190 are required to convert the data to strings and then place the data into buffer 1. This wastes time. Woe to the programmer who uses the Field variable names elsewhere in his

program because he may lose his data in a buffer.

Program Listing 4 implements Snapp V to do the same thing as Listing 3. In line 200, all variable names as used in the program are passed to Snapp V through the string following SCMD PUT. I could have used the same technique as I did in Listing 2, lines 95 and 120, but I chose this method to demonstrate Snapp V's versatility and simplicity.

Snapp V gives you a new data type, the one-byte integer which can have the value of 0-255. This

one helps you to pack data that will not exceed the value of 255.

All the Snapp Extended programs are aimed to save the programmer time and trouble, and to save the computer memory. Snapp II through V become a part of your Basic interpreter, and does not even take up disk space in your Model II. To install the software on your Model II disk you need only follow the simple installation procedures that come with the disk, and soon your Radio Shack Basic will be up and running with the Snapp enhancements. ■

```

90 INPUT "Enter desired record number";K%
100 OPEN "D",1,"STOREQUI",25
110 FIELD 1,2 AS ST$,2 AS PS$,2 AS PV$,2 AS PE$,
120 IF K% > LOF(1) THEN CLOSE 1:END
130 GET 1,K%
140 WEIGHT% = CVI(ST$)
150 DRAG1% = CVI(PS$);D2% = CVI(PV$)
160 D3% = CVI(PE$);D4% = (PN$)
170 NA$ = DES:REM NA$ now equals the load description
180 CLOSE 1
190 END

```

Program Listing 1

```

90 INPUT "Enter desired record number";K%
95 DI$ = "WE%,DR%,D2%,D3%,D4%,(15)NA$"
100 OPEN "D",1,"STOREQUI"
110 IF K% > LOF(1) THEN CLOSE 1:END
120 SCMD GETDI$,1,K%
130 CLOSE 1
140 END

```

Program Listing 2

```

100 INPUT "Enter weight";WE%
110 INPUT "Enter 4 drag numbers";DR%,D2%,D3%,D4%
120 INPUT "Enter 15 character description";NA$
130 INPUT "Enter record to be updated";K%
140 OPEN "D",1,"STOREQUI",25
150 FIELD 1,2AS ST$,2AS PS$,2AS PV$,2AS PE$,2AS PN$,15AS DES
160 LSET ST$ = MKI$(WE%);
LSET PS$ = MKI$(DR%);
LSET PV$ = MKI$(D2%)
170 LSET PE$ = MKI$(D3%);LSET PN$ = MKI$(D4%)
190 LSET DES = NA$
200 PUT 1,K%
210 CLOSE 1:END

```

Program Listing 3

```

100 INPUT "Enter weight";WE%
110 INPUT "Enter 4 drag numbers";DR%,D2%,D3%,D4%
120 INPUT "Enter description up to 15 chrs";NA$
130 INPUT "Enter record to be updated";K%
140 OPEN "D",1,"STOREQUI",25
200 SCMD PUT "WE%,DR%,D2%,D3%,D4%,(15)NA$",1,K%
210 CLOSE 1:END

```

Program Listing 4

ACCEL3

... \$99.95

YOU OWE IT TO YOUR BASIC PROGRAM



BASIC Compiler, Model I/III, all DOS

ACCEL2 Plus:

- Bigger optimized subset
- Quicker compilation
- More compact output
- Almost total compatibility

developed in England by Southern Software



CA add 6%



ALGORIX

Allen Gelder Software

(415) 387-3131

Box 11721 San Francisco CA 94101

Compilers compared.

ACCEL2 and Microsoft's Basic Compiler

ACCEL2
Southern Software
Eastleigh, Hants, England
Distributed by Alien Gelder
Software
Box 11721 Main Post Office
San Francisco, CA 94101
\$88.95

Basic Compiler
Microsoft Consumer Products
10800 Northeast Eighth
Suite 507
Bellevue, WA 98004
\$195

Dennis Wilkins
 4000 Capitol Drive
 Fort Collins, CO 80526

If you have ever wished to speed up your TRS-80 without resorting to hardware modifications, or complete program rewrites in machine code, here are two program packages that can help. The Basic compiler from Microsoft and the ACCEL2 compiler from Southern Software can each compile Basic programs written on a disk-based

TRS-80. There are a few restrictions with each program, however, and each has its particular advantages.

Talking to a Computer

First of all, what is a compiler? There are several ways you can define a series of instructions for a computer. At the most basic level you can communicate in machine code—the only language a computer directly understands. A machine-code listing is a boring list of numbers in hexadecimal, or base 16, for the TRS-80. If you are familiar with the instruction set of the Z80 processor, you may be able to create a listing in machine code, but certainly wouldn't do so for any lengthy programming task.

The most common method of communicating with the TRS-80 is through its Basic interpreter. This is an encoding scheme allowing you to write your program in Basic, read your listings in Basic, and during the Run mode, have the Z80 send instructions in machine code by the interpreter, which is itself a program. This method is easy on the programmer, but makes a lot of work for your Z80. It is busy converting the Basic text to machine code, a line at a time, during the program run. Since the processor spends a large por-

tion of its time interpreting instructions, the effective speed of execution is much less than if the same program were coded in machine code.

If you are an advanced programmer, there is always that mystery of life, Assembly language. This is just another way of writing in machine code, except the hex digits are replaced with two and three-letter words, called mnemonics, which are easier to remember than hex digits. The assembler also provides some other features, such as the labeling of subroutines so absolute memory addresses need not be specified. It is still much like writing in machine code.

Using Assembly language also requires an extra step. After writing the source code using an editor program, one must assemble the code into numeric machine code before running it on the computer using an assembler program. The extra effort yields a program which runs many times the speed of a Basic program because the assembler produces machine code. A program written in Assembly language may run up to 100 times faster than the same operations processed by a Basic interpreter.

Another way to communicate instructions to a computer is

through the use of a compiler. Many well known languages, such as Fortran, are nearly always implemented as a compiled language. Such a language can be structured for ease of programming, like Basic, yet provide high-speed execution, like Assembly language. The main difference between using a Basic interpreter and a compiled language, like Fortran, is the source code must be processed like Assembly language before it is run. The compiler is a program which converts the source code into machine code, but unlike Assembly language, the machine code is not a one-on-one translation of the original program. In fact, one statement of the compiler language may create dozens of lines of machine code. A library of routines, such as square root, trig functions, comparisons, loop controls, are linked onto the compiled code, so you need only specify a function, such as a square root, and not program every step the computer must follow to calculate square root.

Two Compilers for the TRS-80

There are a number of Basic compilers available for the TRS-80. One sold by Radio Shack requires entirely new code to be written—it is not compatible with Level II or Disk

Basic. The two systems described here compile already written and debugged programs using the Basic interpreter. The Microsoft compiler is a *traditional* compiler as described above, whereas the ACCEL2 compiler is something quite unique, a combination of interpreter and compiler.

The compiler from Microsoft appears not to have been written specifically for the TRS-80. It comes with a manual for Basic-80, which is very similar to the TRS-80 implementation of Basic, but with a few enhancements (Swap, While/Wend, and Call, to name three) which can be used in the compiled programs, but cannot be tested in the interpreter mode.

The Microsoft compiler produces a relocatable binary file of machine code which runs from the DOS mode. The version I evaluated came with what appears to be preliminary documentation for the compiler, and the manual on Basic-80. These hopefully, have been cleaned up since the early version I saw. The arrangement of the compiler manual is a bit complex, but by trying the sample session you can get the hang of using the compiler, the linker and the library.

The procedure for using Microsoft's Basic Compiler is quite involved, not automatic. The operator must swap disks and interact with the computer at certain points during the compile and link operations. And the Basic program to be compiled must first be saved on disk as an ASCII file.

By comparison, ACCEL2 is easy to use. Once loaded, the compiler need only be called by the command "/FIX" to automatically carry out the four-pass compile operation. It can be called over and over to compile different Basic programs. ACCEL2 takes about 30 seconds to compile 200 lines of code. The Microsoft system takes several minutes to compile even a short program due to the swapping of disks and loading of library routines.

(If you have a version of ACCEL2 purchased before mid-1981, you will find my descrip-

PROGRAM DESCRIPTION	SIZE	TIME	RATIO
Random Plot - RND, integer arithmetic, set graphics			
Interpreter	637 bytes	231 seconds	1:1
ACCEL2	2202 bytes	171 seconds	1.4:1
Microsoft	11203 bytes	103 seconds	2.2:1
Prime Numbers to 1000 integer counters, single precision arithmetic			
Interpreter	493 bytes	72 seconds	1:1
ACCEL2	1849 bytes	40 seconds	1.8:1
Microsoft	11120 bytes	20 seconds	3.6:1
Population Simulation single precision and many subroutine calls			
Interpreter	5033 bytes	129 seconds	1:1
ACCEL2	8874 bytes	64 seconds	2:1
Microsoft	16216 bytes	27 seconds	4.8:1
POKE graphics with integer counters			
Interpreter	134 bytes	17.5 seconds	1:1
ACCEL2	1564 bytes	0.5 seconds	35:1
Microsoft	10551 bytes	0.5 seconds	35:1
Graphic game with integer arithmetic and SET/RESET graphics			
Interpreter	1738 bytes	27 seconds	1:1
ACCEL2	3634 bytes	3.4 seconds	7.9:1
Microsoft	12455 bytes	2.4 seconds	11.3:1
White out screen with SET and integers			
Interpreter	76 bytes	40 seconds	1:1
ACCEL2	1405 bytes	5 seconds	8:1
Microsoft	3731 bytes	3 seconds	13:1

Table 1

tion differs from what you are used to. There is an updated version, optimized for disk users, available from Allen Gelder Software for \$12 plus the return of your original tape.)

ACCEL2 does not produce a machine-code module, but operates in the Basic interpreter environment with hooks to machine-code routines. It can selectively compile specific types of statements under programmer control. It has statements to Save, Load, or Run compiled programs, and even a limited chaining capability which can load and run both compiled and non-compiled programs from a program which is running.

With ACCEL2, non-compiled statements are processed at run-time by the normal interpreter. This does not mean that a program compiled by ACCEL2 necessarily runs slower than the same program compiled by the Microsoft compiler.

It depends upon the complexity of the program.

The documentation supplied with ACCEL2 (19 pages of utilitarian, but concisely written text) contains a table specifying the ratio of compiled to interpreted speeds for all statements which are compiled. For ACCEL2 these statements are:

```
LET (implied or specific)
AND, OR, <, >, =, <>
+, -, *, /
PEEK, POKE, Set, Reset, Point, VARPTR
For...Next, If...Then...Else, DIM var
name (integer)
GOTO, GOSUB...Return, ON exp GOTO
LEN, MIDS, LEFT$, RIGHT$, CHR$, ASC,
CVI
```

The speed-up ratio (compiled:interpreted) vary from 2:1 (for most single-precision math operations) to 176:1 (for a GOTO). Double-precision math speed-up ratios vary from only 1.02:1 for division to 2:1 for addition. For...Next loops are quickened by a factor of 11:1 (integer only; single-precision

For...Nexts are not compiled, but run in the interpreter mode).

Set, Reset, and Point are increased 7.7:1 (integer), 3.7:1 single precision, and 3.1:1 double precision. If...Then...Else statements improve 17.7:1 for integer arguments, 9.9:1 for strings, 2.7:1 for single precision, and 2.2:1 for double precision.

The most impressive speed increases occur with both compilers when integer arguments are used, since the Z80 CPU directly manipulates these. Although specific function speed-ups are not given for the Microsoft compiler, speed increases of 3 to 10 times are claimed. The tests I ran demonstrated speed-up factors from 1.3 to 11, depending upon the type of function.

Each Compiler's Strengths

If you want to increase the speed of Set, Reset, and Point

graphics, the Microsoft compiler produces only slightly higher increases than ACCEL2. In my tests I found purely graphic programs increased by as little as 1.5:1, to as much as 13:1 using the Microsoft system. The speed-up factor using ACCEL2 varied from 4:1 to 8:1.

On the other hand, programs with much single-precision number crunching may experience only a 2:1 speed-up using ACCEL2, but can exhibit as much as a 5:1 speed-up if compiled via the Microsoft Basic Compiler.

The Microsoft Basic Compiler produces a stand-alone module as mentioned above. This module is self-contained in that every Basic function to be used in the program is appended to the module during the Link operation. The Microsoft compiler does not use ROM routines. The module, therefore, will be quite large if many functions are needed.

For example, a Star Trek program I have occupies exactly

10,002 bytes in Basic. When compiled by the Microsoft compiler it occupies over 27,000 bytes.

The same program compiled by ACCEL2 occupies 16,997 bytes. ACCEL2 needs 5,632 bytes of RAM at compile time, and can use as little as 1,280 bytes at run-time. The TRS-80 ROM routines are used when possible. The compiled code may be larger than the Basic code it replaces, but not nearly as large as the same program compiled by the Microsoft system. For many short programs, the Microsoft system produces at least 10,000 byte modules, whereas ACCEL2 may need only 2,000 to 3,000, including its run-time component. The results of compiling a half dozen programs with both systems is shown in Table 1. The ACCEL2 memory requirements shown include the necessary run-time software.

Logical Code Required

Both compilers may require

that the original Basic program be cleaned up before compilation. To obtain a speed improvement, your code must be logical.

As it turns out, what is perfectly logical for the TRS-80 Basic interpreter may not be logical for a compiler. For example:

```
10 FOR X = 1 TO 10
20 IF R = C THEN NEXT X ELSE GOSUB
500: NEXT X
```

This is fine for the interpreter even though there are two Next X statements for one For statement (this is not a legal construct for all Basic interpreters). The interpreter will get to only one of the Next X statements in any loop.

A compiler rejects this arrangement with an error message ("FN" in the Microsoft version, "Next Without For in 20" in ACCEL2) during compilation. The Basic code is rejected because the compiled code must have a singular control point (same for GOSUB and Returns),

and the compilers view each Next statement as an independent control point.

A logical way to write the code of the above example is:

```
10 FOR X = 1 TO 10
20 IF R = C THEN 30 ELSE GOSUB 500
30 NEXT X
```

There are more restrictions on the program source code (the original Basic listing) with either compiler. Arrays may be dimensioned to a constant size integer value only: 10 DIM A(100)—is OK, but

```
5 N = 100
10 Dim A(N)
```

is not allowed with either compiler.

ACCEL2 has a compiler option (called NOARRAY, set at compile time) which prevents compilation of all array variable references and causes all arrays to be processed by the interpreter at run-time. There are no array restrictions if ACCEL2 is used with this option, but as a

SOFTEK SOFTWARE

Quality Software for Your TRS-80 • For TRS-80 Model I & III Disk or Tape

<p>SOFTEK 100 An assortment of 106 programs including Business, Personal, Educational, Animation, Construction, etc. A list of programs is included \$99.50</p>	<p>SOFTEK PAYROLL Figures all taxes and keeps track of total earnings. Model I & III Disk \$99.50</p> <p>ACCOUNTS PAYABLE Will keep track of total expenses paid out and will print hard copy. Currently used for commissions paid out to broker insurance agents. Model I & III Disk \$89.50</p>	<p>MAIL PROGRAM Keeps a list of over 1,000 names and will display, edit, list, or print mailing labels. Model I & III Disk \$19.95</p>	<p>AIDS SYSTEMS BY METS TECHNOLOGIES MTC AIDS III This easy to use system allows even a novice TRS-80 user to create data files custom configured for many applications. From lists for mailing and cataloging to financial reporting and time scheduling. It requires NO PROGRAMMING and is complete with features for adding, deleting, sorting, updating and printing. MODEL I \$69.95 MODEL II \$99.95</p>
<p>MAIL LETTER Will do the same as mail but you can type up to two letters along with it and the mail letter program will type the letter and put their name and address on the heading and also print "Dear" and their first name. Model I & III Disk \$29.95</p>		<p>THE FLOPPY DOCTOR By Dave Stambaugh FLOPPY DISK/MEMORY DIAGNOSTIC Computer professionals have long known the importance of regular use of diagnostic software in verifying the integrity of computer hardware. The TRS-80 is no exception, good diagnostics are a must. The MICRO CLINIC offers two programs designed to thoroughly check out the two most trouble prone sections of the TRS-80, the disk system (controller and drives) and the memory arrays. MODEL I . . \$24.95 MODEL III . . \$29.95</p>	
<p>SPECIAL FOR MAY SHANNON MAGNETIC 5 1/4" 40 TK DBL DENSITY DISKS Box of 10 \$21.00</p>	<p>SCARFMAN ©1981 Cornsoft Group Model I & III Tape \$15.95 Model I & III Disk \$19.95</p>	<p>MODEL I DOUBLE DENSITY PACKAGE NEWDOS/80 Version 2.0 and Controller Everything you need to convert your TRS-80 Model I to run double density. Complete with software, hardware, and instructions — installs in minutes with NO SOLDERING, WIRING OR CUTTING \$229.95 NEWDOS/80 Version 2.0 for Model I and III \$139.00</p> <p>FLIPSORT File Box Storage for 5 1/4" \$19.95 1 Box Verbatim 5 1/4" Disks with Flipsort \$43.95</p>	
<p>SHANNON MAGNETICS DISK HEAD CLEANERS \$24.00</p>		<p>GROUP INSURANCE QUOTER Good for quoting several plans of insurance, primarily health, and printing hard copy. Model I & III Disk \$99.50</p>	<p>VERBATIM DISKETTES 5 1/4" Double Density and 40 Track Datalife \$25.00</p> <p>SOFTEK SOFTWARE P.O. BOX 702 STERLING, ILLINOIS 61081 815-625-5342</p> <p>MASTERCARD AND VISA WELCOME We Also Accept • COD • CHECKS • MONEY ORDERS ADD \$2.00 FOR SHIPPING</p>

TRS-80™ IS A TRADEMARK OF TANDY CORP
AIDS III, CALCS III, MERGE III, ARE TRADE MARKS OF METATECHNOLOGIES

Write or Call for Complete Price List

Quality Computer Services presents..

Hard Disk Systems

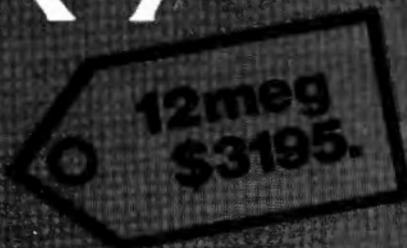

For TRS[®], Apple[®], Heath[®], S-100, IBM.....
6,12,20,40 and 80 Megabyte systems

Completely assembled and tested subsystem including:

- Switching power supply
- Winchester drive
- Host adapter card
- Sealed case
- Expansion

The enclosure, controller and power supply have been designed to allow for future backup hardware or increased storage

- Software
- Auto attach CP/M*
- Hard disk utilities
- Real time clock

- Formatting program
Assigns alternate sectors for any weak sectors detected during formatting assuring the lowest possible error rate

- Warranty: The system has a full one year warranty on all parts and workmanship
- Also available: attach for TRSDOS, OASIS[™], Apple DOS
- Optional 5 1/4" floppy (shown)



See local dealer
or call:
Quality Computer
Services
178 Main Street
Metuchen, New Jersey
201-548-2135

• Quantity discounts available. Distributor, Dealer and OEM inquiries invited.

*OASIS is a trademark of Phase One Systems, CP/M is trademark of Digital Research

QCS inc
Quality Computer Services

Toll free number: 800 631 5944

consequence, the program runs slower.

ACCEL2 has another option: EXPR or NOEXPR. These commands control the compilation of Let, For, POKE, Set, Reset and If. EXPR causes compilation, NOEXPR prevents it. These can be used throughout a program to selectively turn compilation on and off. If not compiled these statements are executed by the interpreter at run-time. As always this slows the operation, but if planned properly, the speed loss will be minimal and the space saved significant.

The Microsoft compiler has many compile options (called switches), but none to do the things described for the ACCEL2 compiler. There are about 20 switches in all, some quite useful (or even necessary for error handling) and some almost incomprehensible. If you like lots of possibilities, the Microsoft compiler has them.

There are other restrictions

common to both compilers. Look at the statement: 999 GOTO 999.

In Basic this sits in a loop until the Break key is pressed. In compiled Basic it sits in a loop until you press the System Reset button or unplug the power cord—an inconvenient way to stop a program!

And the Winner Is...

As I said in the beginning, each compiler has its strong points and weaknesses. The Microsoft offering is part of a system of advanced programs allowing many combinations of languages and functions to interact. It is *not* for beginners. It is quite complex and requires a minimum of 48K in a disk-based system. It offers higher speed-up for mathematical operations and more flexibility for the advanced programmer than ACCEL2.

The large memory requirement of the Microsoft compiler system is a major drawback for

applications requiring much data storage. Having to use a lot of disk accesses rather than RAM, to manipulate data may lose more speed than was gained by compiling in the first place.

ACCEL2 is easier to use, requires only 16K of memory, and offers excellent speed-up performance for logic and graphics programs. It is a program anyone who has mastered TRSDOS can easily operate. I have operated ACCEL2 in TRSDOS and NEWDOS 2.1 on my Model I with no problems. It operates on Models I and III. There is also a tape version available, called ACCEL, for those of you with a tape-based TRS-80 with 16K of RAM. It costs \$49.95.

ACCEL2 has another advantage for those of you who like to sell or trade software you have written: No royalty payment is required. If you distribute programs compiled by ACCEL2, ACCEL2 allows you to make either tape or disk copies of com-

iled software, along with the necessary run-time component. You can sell programs on a Level II 16K, 32K, 48K, or disk based system. Southern Software requests that you put a copyright notice on the tape or diskette label. But, no money is requested.

Microsoft requires nine percent of the end-user price per copy or a flat \$195 per year (cheaper if you sell over \$2166.67 worth of software a year). Users must have a 48K disk-based system, which limits the market for such compiled programs.

I feel that each compiler offers truly improved capabilities for the TRS-80, ACCEL2 being the lower cost alternative (and best for compiling programs of logic and graphics routines). The Microsoft system is aimed at the more advanced programmer, allows one to interface with other languages, and is best at speeding up number crunching programs. ■

The DATA-TRANS 1000

A completely refurbished
IBM Selectric Terminal with
built-in ASCII Interface.

*FOR YOUR TRS-80 WITH OR WITHOUT
EXPANSION INTERFACE. AVAILABLE WITH
CENTRONICS TYPE PARALLEL PORT.

Features:

- 300 Baud Serial
- 14.9 characters per second printout
- Reliable heavy duty Selectric mechanism
- RS-232C Interface
- Documentation included
- 60 day warranty—parts and labor
- High quality Selectric printing Off-line use as typewriter
- Optional tractor feed available
- 15 inch carriage width

Also works with Exatron's Stringy floppy, for fast loading of programs. (Has RS232 built in stringy)

HOW TO ORDER DATA-TRANS 1000

1. We accept Visa, Master Charge. Make cashiers checks or personal check payable to:
DATA-TRANS
2. All orders are shipped F.O.B. San Jose, CA
3. Deliveries are immediate



Desk and table top models also available.

For orders and information

DATA-TRANS

45277 Fremont Blvd., #7 108
Fremont CA 94538

Phone: (408) 263-9246

Announcing

LOG

ELECTRONIC NOTEBOOK

LOG Documentation	PAGE 2	08 02 81	16 04 00 P
CONTENTS			
Cursor positioning commands	pages 3, 4		
Page positioning commands	pages 5, 7		
Write commands	pages 8, 11		
Line printer commands	page 12		
Special commands	pages 13, 14		
Search commands	pages 15, 20		
New page creation	page 21		
Entry options	pages 22, 26		
Exit	page 27		
Technical information	pages 28, 33		
Suggestions for use	pages 34, 37		

continue to next page

A totally new concept in small scale information management for the TRS 80 (R) LOG is an assembly language utility which fills the gap between text editors and data base managers to provide a true free form information storage and retrieval system with unheard-of ease of operation.

LOG CMD creates on a formatted diskette a LOG file from 1 to 170 pages long, each page containing 1 full screen of information. Pages are accessed individually or sequentially, as if thumbing through a book. Information is added, updated, or deleted from each page in free form by an integral cursor oriented text editor. Each diskette becomes a separate organized notebook to use and re use as you please.

Insert, Delete, Tab, Clear, and full cursor positioning are supported, as well as blinking cursor and auto-repeat. All functions operate with the ease of a single keystroke including Global Search. Output to printer is provided. LOG can even be accessed from BASIC without loss of program.

Why, when you own a computer, do you still keep records by hand? Throw away your pencil and paper! Use your computer as you never dreamed of before!

Model I	32 or 48K	\$44.95	(uppercase only)
Model III	32 or 48K	\$49.95	(uppercase/lowercase)
(minimum system 32K, 2 disk drives, DOS 2.3 (I) or 1.3 (III) required)			

Write or Call for further information

KSoft
318 Lakeside Drive
Brandon, MS 39042

(601) 992-2239

MasterCard and Visa accepted
MS Residents pay 5% sales tax.
We pay shipping and handling

(TRS 80 is a trademark of Tandy Corporation)

→331

We Have The Lowest Price

OKIDATA

Microline 80 S349 Delivered
82A S484

EPSON, KESA, ELF II software, Self Teaching Guides.
Call or write for information!!

MEMORY

16K 200ns CERAMIC DIP
w/instructions for TRS 80
mod I, III
NONE BETTER FOR \$1.65 ea.

VERBATIM

MD525-01, single side, soft
sectored
\$24.95/10 w/ plas lib case \$27.95

SELF TEACHING GUIDES — takes you step by step through your micro

TRS-80 Basic \$8.95 more TRS-80 Basic \$8.95
8080/280 Assy Lang \$9.95 USING CP/M \$8.95
DATA FILE PROGMMG IN BASIC \$9.95
FLOW CHARTING \$8.95

Terms: Cash, Money
Order, Check (1 wk to
clear); VISA, Master
Card, add 3%
Shipping add \$3.00,
over \$50.00 shipped
free, COD add \$2.00

OKIDATA INC.

P.O. Box 1567 • Wheat Ridge, CO 80034
303-431-4154

→44

**Computer
Case
Company**

Comp Case



• RS201

Attaché style cases for carrying and protecting a complete computer set-up. Constructed of the highest quality luggage material with saddle stitching. Will accommodate equipment in a fully operational configuration along with manuals, working papers and disks. Never a need to remove equipment from case. Simply remove lid, connect power and operate. Lid can be replaced and locked for security and protection without disconnecting cables. Fully tested.

• RS201	TRS-80 Model I, Expansion Unit & Drives . . .	\$109
• RS202	TRS-80 Monitor or TV set	84
• RS204	TRS-80 Model III	129
• RS205	Radio Shack Color Computer	89
• P401	Paper Tiger 440/445/460	99
• P402	Line Printer II/IV	89
• P403	Epson MX70 or MX80	89
• P404	Epson MX100	99
• CC90	Matching Attaché Case	75

computer case company

5650 INDIAN MOUND CT. COLUMBUS, OHIO 43213 (614) 868-9464

→139

Model 953A EPROM PROGRAMMER

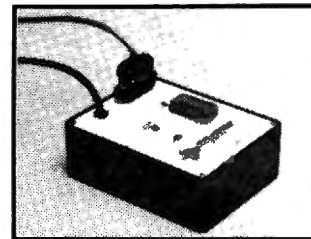

- Programs 2508, 2758, 2516, 2716, 2532 and 2732 five volt EPROMS.
- Complete - no personality modules to buy.
- Intelligent - microprocessor based, programs and verifies any or all bytes
- RS-232 serial interface - use with computer or terminal.
- Verify erasure command - verifies that EPROM is erased.
- Extended diagnostics - error output distinguishes between a bad EPROM and one which needs erasing.
- May be used for extremely reliable data or program storage.
- All power on programming socket under processor control. LED warning light indicates when power is applied.
- Complete with Textool zero insertion force socket.
- High performance/cost ratio.
- Standard DB-25 I/O connector.

PRICE \$289



BAY TECHNICAL ASSOCIATES, inc.

HWY. 603, P.O. BOX 387
BAY ST. LOUIS, MISSISSIPPI 39520
(601) 467-8231

→243

Recover those lost 1023 bytes of RAM.

The Memory Box

**The Memory Box
Displayed Video**
7538 Jackson Road
Ann Arbor, MI 48103
\$49.95 Model I

Jack Decker
1804 West 18th St., Lot 155
Sault Ste. Marie, MI 49783

The Memory Box consists of a small (approximately 4 by 3 by 1 1/2 inch) plastic box with a TRS-80 standard 40-pin edge connector emerging from a slot in one side, and a plug-in five-volt power supply permanently attached by a five-foot cord. On the unit I received, the power supply has a switch which permits operation on either 110-volt or 220-volt circuits, but this feature is not mentioned in either the company's advertising or the documentation for the Memory Box.

Displayed Video provides a short (four-inch) cable that has a 40-pin edge plug attached to each end. In normal use, one end of the plug is connected to the edge connector on the Memory Box, while the other end is connected to the expansion edge connector on the rear of the TRS-80 keyboard unit. I assume that you can also make this latter connection to the screen printer connector on an expansion interface unit, but I was unable to verify this because I do not have an expansion interface.

The Memory Box provides 1K of additional RAM in memory locations 3000H-33FFH (12288 decimal-13311 decimal). Normally, this area of memory is unused in the Model I TRS-80. Because the TRS-80 (and most programs) do not expect any memory to be present at these locations, anything stored in this area will not normally be overwritten or changed. Therefore, you can store machine-language utilities (or other programs or data) in this area for recall at any time, regardless of the program or data that you store or use in the regular user memory. The Memory Box retains the contents of its memory even if the power to the TRS-80 keyboard unit is switched off. You can store utilities in the Memory Box and recall them after each power up (provided that there has not been a power interruption in the Memory Box itself).

My TRS-80 has a lowercase modification installed. In order to use it, I formerly had to load a machine-language patch to the keyboard and video drivers each time I turned on the computer. This patch program resided in high memory, and was often in conflict with other machine-language programs or utilities that I wished to use. Now I keep the patch program permanently stored in the Memory Box, and after each power up, I type the following from the Basic Ready prompt:

```
>SYSTEM
*? 12288
```

(12288 decimal = 3000 hexadecimal, which is the entry point for my driver patch program). This is much easier than trying to find the cassette tape with the patch program on it, and then waiting for the program to load. Also, because the program resides in the Memory Box, it does not conflict with other machine-language or Basic programs that load into regular user RAM, and it does not reduce the amount of memory available to these programs.

You can also use the Memory Box to store variables for use by more than one Basic program, as in a case where one program chains to another. In such a case, you could place values into or retrieve them from the Memory Box by using Basic POKE and PEEK statements, or possibly by using a machine-language USR function to move the values of certain variables to or from the Memory Box.

I experienced a slight problem when I attempted to connect the Memory Box to my TRS-80 keyboard unit. I normally use a JPC Products TC-8 high-speed cassette unit and a homebrew printer interface, which was already connected to the edge connector on the back of my TRS-80. The cable that connects the TC-8 to the TRS-80 is the same configuration as the one supplied with the Memory Box, except that it is much longer. To

solve the problem, I purchased another 40-pin edge plug from Radio Shack (catalog number 276-1558), and using a bench vise I pressed it onto the TC-8 cable about three inches from one end. The result was two plugs near one end of the cable, and one plug at the other end. Now I can plug the end with one plug into the back of the TRS-80 keyboard unit, and the plugs on the opposite end connect to the TC-8 and to the Memory Box (I do not use the cable supplied with the Memory Box). This hookup works well, and I have noticed no adverse reactions from the TRS-80, the Memory Box, or the TC-8 unit/printer interface.

Once connected, the Memory Box has never failed to work reliably, even with a high-speed modification (200 percent of normal speed) in use on the TRS-80. If it can work at high-speed, with the TC-8 and printer interface also hooked up to the bus connector, it must be reliable.

Improvements

You have probably run into the situation where a machine-language program goes bonkers and starts writing random bytes into various places in memory. This can happen if you turn off the computer, and then immediately turn it back on without allowing a few seconds for the circuits to discharge. This sort of unwanted activity by the CPU can also write garbage into the

MORE BYTES FOR YOUR BUCKS

CP/M Compatibility Plus 64K RAM
for your TRS-80

Freedom Technology International --- PRESENTS

Freedom Option

CP/M Compatibility for your TRS-80 Model I and III, PMC 80 and 81, and LNW 80 systems.

Freedom Plus

CP/M Compatibility Plus 64K RAM for your TRS-80 Model I and III.

TWO SYSTEMS IN ONE

Run CP/M application programs in addition to TRSDOS

INDUSTRY STANDARD

Enter the world of powerful CP/M application programs; WordStar, dBase II, etc.

OPEN AND SHUT CASE

EASY to install, plug-in boards; no wires or traces to cut; no soldering.

TECHNICAL BACKGROUND

Over 50 years of high technology experience...from Maxi's to Micro's...both Hardware and Software.

FREEDOM OF CHOICE

T8/OS (our powerful Z-80 code operating system) and CP/M 2.2 if you choose.

- Dealer Inquiries Invited
- Six Month Warranty
- 30 Day Money Back Guarantee

Freedom Option\$275.00

Freedom Plus\$490.00

Manual Only\$ 25.00

Call us for information about our large selection of CP/M application programs.

To order Call Toll Free
1-800-523-4067
In Pennsylvania call
(215) 569-2381

TRS-80 is a registered trademark of Tandy Corp.
LNW-80 is a registered trademark of LNW Research Corporation
PMC 80,81 is a registered trademark of Personal Microcomputer Inc.
TRSDOS is a registered trademark of Tandy Corp.
CP/M is a registered trademark of Digital Research Inc.
WordStar is a registered trademark of MicroPro Int. Corp.
dBase II is a registered trademark of Ashton-Tate

Freedom Technology International

119 North 18th Street, Philadelphia, PA 19103

SCRIPLUS 3.0

Scriplus is a modification to Scripsit[®] which enables you to take advantage of the special functions, features, and print formats of your printer while your document is being printed. Allows you to:

change expanded print
change no. of characters per inch
or underline in mid-line!

- 1) Send commands to the printer to activate special formats!
- 2) SCRIPPLUS will NOT crash programs protected in hi-mem!
- 3) "END" returns to DOS READY instead of re-booting!
- 4) Initial line feed is changed to a carriage return to empty text buffer!
- 5) The use gets an ALPHABETIZED Directory (with FREE space shown) from within SCRIPPLUS!
- 6) Optionally select line feed after carriage return
- 7) Supports custom printer drivers (NOT included)
- 8) Modifies ALL versions of SCRIPSIT(tm) for Mod I or III. Allows you to use Mod I version on Mod III!
- 9) Printer can be STOPPED for insertion of text or forms alignment!
- 10) Inserted text can be edited prior to resumption of printing!
- 11) Files can be killed, loaded, merged, or chained from the SCRIPPLUS DIRectory!
- 12) Allows Mod III versions to be BACKED UP for your protection!
- 13) Works on ALL current major DOS's (Mod I or III)
- 14) Works with new 3.2 Mod III Scripsit on 1.3 DOS!
- 15) Specifically written for the MX-80, but will work with ANY printer that accepts CHR% codes for control!
- 16) Previous owners may send in their disks for upgrade (\$15)

\$39.95

POWERSOFT

GREAT for EPSON's! With or without GRATRAX-80(tm) v61

11500 Stemmons Expressway - Dallas, Texas 75229

M/C-VISA
CARDS
Accepted

(214)484-2976 -- MicroNet# 70130,203
Join OUR Xtra-80 Sig ON MicroNet!
From the "OK" prompt, type: R BSD

Write for
our FREE
Catalog!

DEALER INQUIRIES INVITED

US/CANADA Orders ADD \$5 Shipping/Handling
See us at NCC in Dallas! April 21-25!
PowerSoft is a division of Breeze/BSO, Inc.
SCRIPSIT is a registered TM of TANDY CORP.

FOREIGN add \$10
U.S. FUNDS ONLY
for shipping.
NO CHECKS!

Memory Box, thus destroying any resident programs or data.

For that reason, the Memory Box should have a write-protect switch—flip it on, and the memory inside the Memory Box would suddenly look like ROM (Read Only Memory) to the CPU. Any writes to addresses contained within the Memory Box would be ignored, so that a loss of power would be about the only thing that could destroy the memory contents. With the switch in the opposite position, normal operation (read or write allowed) is restored.

If you have a Memory Box and would like to add such a switch, wire it in such a way that pin 13 of the 74LS00 integrated circuit is either connected to its present place in the circuit (normal operation) or to +5 volts (write protect).

Displayed Video warns against operating the CPU with the power disconnected from the Memory Box, as this causes abnormal bus loading and reduces the reliability of the TRS-80 system. Therefore, disconnect the Memory Box from the computer if you have to pull its plug.

If you do not care to write your own software routines for use in the Memory Box, Displayed Video has several utility routines available (at extra cost). Both will work with either disk or tape systems, and both use the @ key along with another key to access certain features of the programs.

The U3000 utility contains a keyboard debounce routine (you can change the debounce delay by using a POKE command), a cassette level meter program that is designed to aid you in setting the volume control on your cassette recorder to the proper playback volume, a screen printing routine (dumps the contents of the video display to the printer), and a versatile line printer support program. This latter program allows you to format printouts according to various parameters that you can change by using POKE statements. It even prints the page number at the bottom of the page. You can change program parameters such as number of

printed lines per page, number of lines from the last printed line on a page to the page number, number of lines from the page number to the first printed line on the next page, minimum line length, maximum number of characters per line, margin width of continuation line, ASCII codes of terminating characters, page number, horizontal print position of page number, and whether or not the computer must supply a line feed after each carriage return (required by some printers).

By pressing two keys on the keyboard, you can do a top-of-form, or reset the line, character, and page counts (you would do this after manually positioning the printer to top-of-form). You can also defink the line printer program, and use the printer driver supplied in the ROM. Later on, you can reverse the process and reinstate the line-printer program by pressing a couple of keys.

Displayed Video also offers MICMON. MICMON has the screen-printing and keyboard debounce routines of U3000, but in addition has a Micro-Monitor program. With the Micro-Monitor you can dump memory to the video display in either hex or ASCII format, edit memory locations, move blocks of memory from one address to another, load a block of memory locations with one byte, compare the contents of two memory blocks, search memory for a given byte, punch a System tape, or return to DOS or Basic. It is not T-Bug (you cannot set breakpoints or display register contents, for example), but then T-Bug uses more than the 1K of memory available in the Memory Box.

The Memory Box uses the same area of memory as the PROM operating system of the Exatron Stringy-Floppy. Therefore, Stringy-Floppy users would not be able to use the Memory Box while the Stringy-Floppy is connected. I do not know of any other major add-on devices for the TRS-80 that use this area of memory, so unless you own a Stringy-Floppy, you should find the Memory Box a useful addition to your Model I TRS-80. ■

YES, I want to save hours of typing and aggravation!

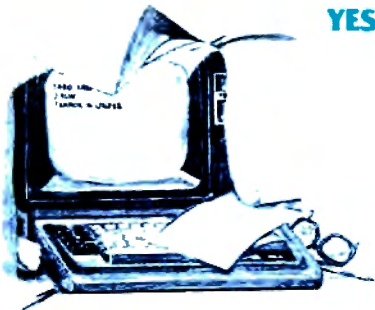

YES. I want the May 1982 **LOAD-80** on disk for \$19.97 each (plus \$1.50 per disk for postage and handling).

YES. I want to save money. I'll subscribe to **LOAD-80** on disk beginning with the May 1982 issue \$199.97 a year.

YES. I want a cassette of the May 82 **LOAD-80** for \$9.97 each (plus \$1.50 per tape for postage and handling).

YES. I'll save 30%. Sign me up for a year of **LOAD-80** beginning with the May 1982 cassette \$99.97 for 12 issues.

VISA Am. Ex. MasterCard Check/money order

Name _____

Address _____

City _____ State _____ Zip _____

Sig. _____

Card # _____ Exp. date _____

LOAD 80 is manufactured by Instant Software, a subsidiary of **WAYNE GREEN INC.** Peterborough, NH 03458. There is no warranty expressed or implied that **LOAD 80** will do anything other than save you typing.

Foreign air mail, please inquire.

5/82



NO POSTAGE
NECESSARY
IF MAILED
IN THE
UNITED STATES

BUSINESS REPLY CARD

FIRST CLASS PERMIT NO. 80 PETERBOROUGH, NH 03458

POSTAGE WILL BE PAID BY ADDRESSEE

LOAD-80

Att. Debra Boudrieau

WAYNE GREEN INC.
80 PINE STREET,
PETERBOROUGH, NH 03458



**LOAD 80 IS NOW
AVAILABLE ON DISK**

**Tired of typing in all
your programs?
Save time
and money!**

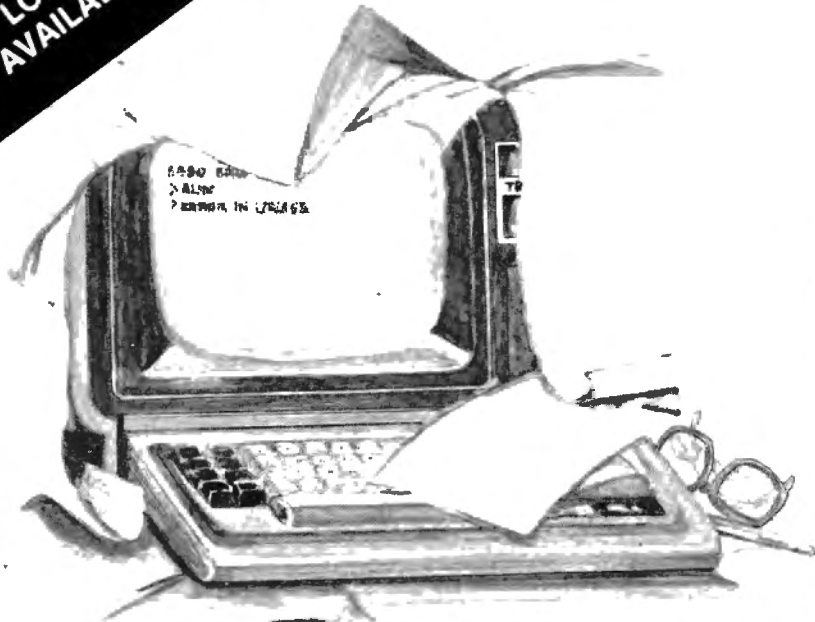

**ALL THE
MAJOR PROGRAM
LISTINGS FROM
EACH ISSUE OF
80 MICROCOMPUTING**

\$9.97
Plus \$1.50 ea. Postage & Handling

**SAVE HOURS OF
TYPING & AGGRAVATION**

**Sign up for a subscription to LOAD 80. Save up to 30% off the monthly price.
Begin your subscription with the May 1982 cassette or disk.**

LOAD 80 disks are TRSDOS 2.3 formatted, single density and floppy-sided. They will not contain an operating system. Single drive users need a single drive copy utility; Model III users need the TRSDOS 1.2/1.3 Convert utility. Source code files may not be useable on the Model III.

"Frankly, after hundreds of hours of frustration, I seldom ever try to keyboard a published program. Inevitably, I mess it up when I keyboard it. Who needs the aggravation?"

"This is why I started a new series of cassettes called LOAD-80. Each cassette will have program dumps of the listings in an issue of 80 Microcomputing. These listings are direct from the authors and tested by the 80 Microcomputing staff. All but the very short program listings will be on the LOAD 80 cassettes. Thus, you will be able to save hours of inputting programs and even more of debugging your keyboard errors."

Wayne Green
Publisher, 80 Microcomputing

The LOAD 80 cassette is simply the program listings that appear in the articles in 80 Microcomputing. It was created to save you the time involved in typing the listings yourself. Successful loading of the programs depends on reading the documentation in the articles. If you have your current magazine at hand when you load the cassette or boot up the disk, you should have no difficulty. If you still have problems, please return the tape or disk for replacement.

LOAD 80 began with the April 1981 issue. To order back issues, look for the back issue advertisement in this magazine or ask your local dealer.

To order LOAD 80, fill in the attached card and we will send you your LOAD 80 cassette or disk for the major programs in this issue. If the card is missing, fill in the coupon below (a photocopy is acceptable) and mail to: LOAD 80, 80 Pine Street, Peterborough, NH 03458.

Yes, I want May LOAD 80.

- YES, I want a cassette of the May 1982 LOAD 80 for \$9.97 each (plus \$1.50 per tape for postage and handling).
- YES, I'll save 30%. Sign me up for a year of LOAD 80 beginning with the May 1982 cassette \$99.97 for 12 issues.

- Visa Am. Ex MasterCard
- Check/Money order

- YES, I want the May 1982 LOAD 80 on disk for \$19.97 each (plus \$1.50 per disk for postage and handling).
- YES, I want to save money. I'll subscribe to LOAD 80 on disk beginning with the May 1982 issue \$199.97 a year

Name: _____
Address: _____
City: _____ **State:** _____ **Zip:** _____
Signature: _____ **Card#** _____ **Exp. Date:** _____

LOAD 80 is manufactured by Instant Software, a subsidiary of WAYNE GREEN INC., 80 Pine St., Peterborough, NH 03458. There is no warranty expressed or implied that LOAD 80 will do anything other than save you typing. Foreign air mail, please inquire.

Some computer mysteries explained.

Technological Destiny

Gary J. Dillio
1109 Madison Avenue
Prospect Park, PA 19076

In Part 1 of this series we looked at the basic computer, its logical components and forms of input and output. In this part I will explain data hierarchy, computer history and discuss common misconceptions.

Data Hierarchy

Computers store, transfer and operate on *data*. *Data* is any fact entered into or received from a computer. *Information* is data that has been collected, evaluated, sorted, organized or processed. Figure 1 shows a collection of seemingly unrelated data elements. By processing those data elements through a program designed to rank (sort) and compare data to an average standing, information whose worth is greater than the individual data elements is obtained (see Fig. 2). The synthesis of the data in Fig. 1 produced the information in Fig. 2.

The smallest piece of data represented in a computer is a

Jones	36
Smith	72
Wilson	64
Marks	12
Average Standing	48

Fig. 1. Data

Placement	Name	National Standing
1	Smith	+24
2	Wilson	+18
3	Jones	-12
4	Marks	-36

Fig. 2. Information

binary digit or a *BIT* (*B*inary *I*digit). A bit is the only form of data a computer can process. All higher forms of data must be broken down to their bit forms before processing. Fortunately, the computer handles this process.

A bit consists of either the presence or absence of data. The presence of a data bit is coded as a "1," and is said to be "on." The absence of a data bit is coded a "0," and is said to be "off." In a light bulb, the absence of electricity to the bulb (0) represents off while the presence of light (1) represents on.

Since only the numbers zero and one can be represented in a computer bit, the only numbering system applicable to bit-processing is the binary number system. Just as the decimal system has decimal places, the binary system has place values. Figure 3 shows decimal and binary place values. The decimal system places are differentiated by multiples of 10 (base 10). The binary system works on multiples of 2 (base 2). In decimal, the number 169 represents 1 hundreds, 6 tens and 9 ones. To represent this number in binary, it is necessary to turn on the bits in binary, representing decimal 169.

In Fig. 4, 128 plus 32 plus 8 plus 1 equals 169. The number 169D is represented by 10101001B.

Most computers use a hexadecimal-binary code to represent numbers and letters.

Gary Dillio is a Computer Systems Analyst for the Department of the Navy.

The next higher data form is the *character*. While the bit is the smallest (and only) unit of data recognized by the computer, the character is the smallest unit of data used by humans. Primarily, characters include letters, numbers and punctuation symbols. Characters are broken down into bits automatically by the computer. A character is usually represented by 8 bits.

A group of one or more characters form the next level of data hierarchy: the *field*. A field is a variable length group of characters which convey a meaning. A field is often referred to as a data element. Fields are the lowest form used to convey separate and autonomous meaning. In Fig. 2, there are three fields: Placement, Name and National Standing.

A group of related fields all referring to the same subject form a *record*. The fields Name, Address, Phone Number and Age for one individual combine to form a record. A group of related records form a *file*, and a group of related files form a *data base*.

The key word in data hierarchy is relationship. A group of unrelated files do not form a data base. The record we have spoken about thus far is a *logical record*. A logical record is a group of related fields. Since

I/O speed, especially in cassette-based systems, is slow, records are often grouped together in blocks. Block sizes are determined by the limitations of the computer.

A logical record with a length of 40 characters is written on tape by opening the tape; allowing the cassette mechanism to stabilize speed; writing a heading; writing a record; writing a trailer; and closing the tape. If five records are written, each encompasses the above six steps for a total of 30 actions. If we group the five records into a block of 200 characters by concatenation and then write the concatenated record to tape, we save 24 steps and a great deal of I/O time. This blocked record is sometimes referred to as a *physical record*. A physical record is defined as one or more logical records joined together for the purpose of decreasing the number of I/O's while increasing the speed of I/O transfer.

Historical Perspective

Very few industries can claim the quantity, quality, and speed

DECIMAL (Base 10)
1,000's/100's/10's/1's
BINARY (Base 2)
8's/4's/2's/1's

Fig. 3. Bases

Binary Position	128's	64's	32's	16's	8's	4's	2's	1's
1:on								
2:off	1	0	1	0	1	0	0	1

Figure 4.

LYNN'S A/R SYSTEM

12 Intergraded Account Receivable Programs

Tested In Service For Over 3 Years

User's Comments: • menu driven • increased cash flow • saved over 50 hours a month in secretarial hours • almost completely eliminated billing errors • phone supported-ask for Ron.

LYNN'S A/R SYSTEM WILL

- print invoices
- tell you your a/r total, number of invoices outstanding, average per invoice
- tell you at any time how many invoices an individual account has open, the total amount owed, the average per invoice, the invoice date, and then invoice amount
- total sales on account for a given month, number of invoices sent, average sale per invoice
- how much an account purchased during month, how many invoices were sent, average invoice for month
- tell you what percent of sales an account is to total sales by month
- tell you what percent of a/r an account is
- print mailing labels for your accounts
- print statements at any time you want them (either individual or all accounts)
- print alphabetical hardcopy of accounts and account numbers
- print all items sold for month
- alphabetical sort of items sold by month
- this set of programs can be custom modified by you or us
- AND MUCH MORE!!

AGING REPORT FOR LYNN'S A/R SYSTEM

Aging Report 01/31/82 Page 1

Account	Current	30-60 Days	60-90 Days	90+ Days	Total
ABC Inc.	\$ 249.00	\$ 65.20	\$ 00.00	\$ 00.00	\$ 314.20
Old Co. Inc.	00.00	84.40	165.20	00.00	249.60
New Co. Inc.	97.75	00.00	00.00	00.00	97.75
Deadbeat Inc.	00.00	00.00	00.00	345.00	345.00

Totals \$346.75 \$ 149.60 165.20 345.00 \$ 1,006.55

Aging reports can be compiled on a daily, weekly or monthly bases.

LYNN'S CHECKBOOK LEDGER SYSTEM

•Phone Supported Ask For Ron•

- saves hours of posting to general ledger
- almost completely eliminates mathematical errors
- menu driven
- 200 expense fields
- will handle 1,000 checks a month
- will print checks with option to enter handwritten checks
- will do reconciliation statement with hardcopy
- will print hardcopy of field totals both by month, year to date and end of year
- automatic account numbering
- automatic field entry
- will print hardcopy of checkbook register
- debit and credit memo entry
- alphabetical hardcopy of accounts payable and account numbers (machine language sort, very fast)
- AND MUCH MORE! •

DATA BASE MANAGER BY WELLS

perfect tool for storing and maintaining mailing list, inventories, menus, collection records, article references, important dates, client records • all functions menu driven • easy to interface to word processors and communication programs • sort in ascending or descending order (fast machine language sort) • compact storage with minimum overhead • go from data base to visicalc and return • sort and select visicalc lines!! • interface to Radio Shack's "advanced statistical package".

LYNN'S

Account Receivable System	\$49 ⁹⁵
Account Receivable Aging Report	\$20 ⁰⁰
Checkbook Ledger System	\$69 ⁹⁵
Well's Data Base Manager	\$39 ⁹⁵

Add \$2.00 Freight and Handling.

Illinois Residents Add 6% Sales Tax

Send \$10.00 Per System
For Printouts and Documentation.
Credit Given on Order

Equipment Needed: 48K Model I or III,
Lineprinter, 2 Disk Drives.

The above programs will work on TRSDOS 1.2 and 1.3 for the Model III. NEWDOS, NEWDOS80, NEWDOS80 V2.0, LDOS and MULTIDOS for the Model I and III.

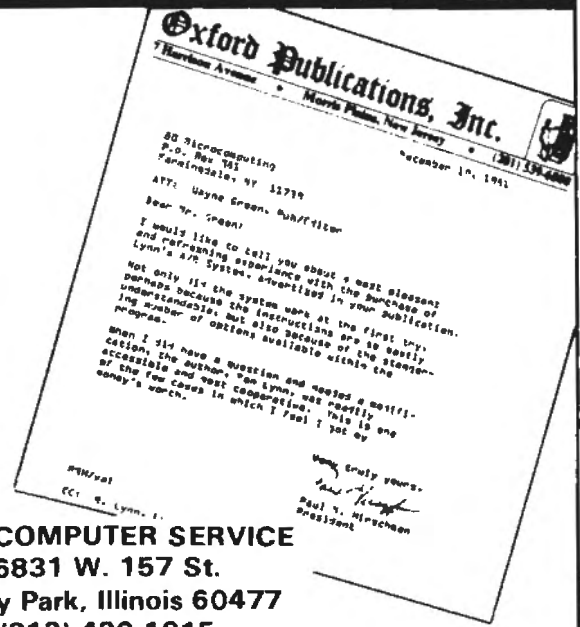

LYNN COMPUTER SERVICE
6831 W. 157 St.
Tinley Park, Illinois 60477
(312) 429-1915

-115

TRSDOS and TRSDOS are trademarks of TANDY CORP. NEWDOS and NEWDOS80 are trademarks of APPARAT INC. LDOS is a trademark of LOGICAL SYSTEMS INC

of progress that the computer industry has achieved in the last quarter century. But, as with most industries, a trail of minor discoveries, dating as far back as 1812, led to today's computer.

Probably the first invention in the chain was developed in 1812 by Charles Babbage. Babbage developed his "difference machine" to automatically perform simple computations used in logarithmic tables. More importantly, he developed an analytic engine which executed operations similar to a program and was capable of internal storage of data. Machines to aid

in physical labor were being developed rather quickly in the early 19th century, but the invention of the analytical engine introduced the idea of mental-assist machines.

The Laws of Thought, published in 1854 by George Boole, described a systematic approach to the analysis of problem solving. It forms the basis of computer logic as we use it today. Herman Hollerith invented the machine-readable punched card code in 1890. Today, over 90 years later, the Hollerith code is still in use.

Modern computers were not

invented until the late 1940's. Although a number of companies and colleges were developing computer-like machines, credit is usually given to Eckert and Mauchly of the University of Pennsylvania for the first electronic computer, called the ENIAC.

ENIAC led to the development of the UNIVAC Corporation. UNIVAC installed their first computer at the US Bureau of Census in 1951. That computer is now displayed at the Smithsonian Institute.

Computer development can be broken down into three distinct generations. The first, beginning with ENIAC and continuing into the late 1950's, produced a vacuum tube machine the size of a very large room. The first generation machine required a programmer who understood the machine almost as well as its engineer. The machine was large, slow, difficult to program and had a relatively small memory capacity. These first computers gen-

erated a great deal of heat and required large air conditioning systems.

With the development of the transistor by Bell Labs, second generation computer systems (1959-1964) came of age. Transistors replaced the vacuum tube. Computers became smaller, faster, less expensive and used less electricity. These new computers generated less heat and had larger memory units for more effective storage. New languages made writing programs much easier.

Printed circuitry (1964) ushered in the third generation. As computers became smaller and faster, reliability increased. Breakthroughs established communication possibilities and more efficient I/O methods. Memory again increased and the sophistication of software operating systems further simplified programming.

To appreciate the advances in the computer industry within the last 35 years, compare the ballroom-size ENIAC with

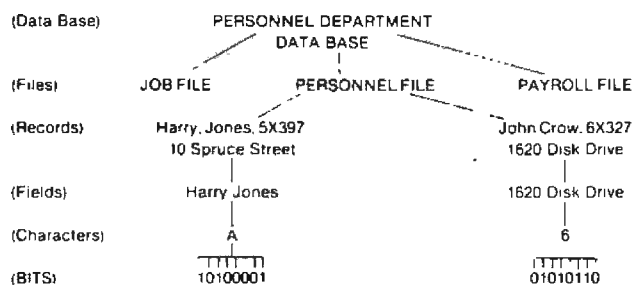

Fig. 5. Data Hierarchy

Mayday IS NOW SMART

Mayday has established itself as the best protection against power interruptions to most mini / micro-computers.

Mayday now has all the features you asked for!



- Constant voltage regulated output
- I/O port which tells computer when AC is off
- High, low and charge LED indicators
- Low battery audible alarms and UPS shutdown
- High start up capability for hard disk
- Zero crossing DC feature that handles any type of computer power supply
- New three stage sense circuit that protects from all types of power failure-including rapid inductive kickback

...protection you can afford!



SUN RESEARCH, INC.
BOX 210 OLD BAY ROAD
NEW DURHAM, NH 03855
(603) 859-7110 TWX 510-297-4444

285

today's TRS-80. The micro-computer of today can outperform the ENIAC at one ten-thousandth of the cost and three-thousandths of the size. The progress goes on and on. Even so, the computer industry has only just reached the toddler stage of its development.

Although it is too early to accurately gain proper perspective, many data processors believe we are now into the fourth generation. As computer size and price diminish, memory and peripheral inventions continue to alter old computer realities. I do not think the fourth generation will be defined by great discoveries, but by the use and users of the new microcomputers. How many of us believed, only a few years ago, we could own a microcomputer? Small, inexpensive computers of five or ten years ago sold for \$90,000. Computer uses have expanded to include shopping lists, menu planning and games.

Users are no longer exclusively data processors, scientists

and businessmen. Microcomputers have introduced housewives, teachers, students, children and other nontechnical personnel to computer use. Software applications have tripled over the past five years and, as the price of microcomputer products diminishes, the market for home computers expands. A year ago, I bought 16K for \$55. Today, \$60 buys 48K. Each price reduction opens the market to more people who, not long ago, would have laughed at the prospect of owning a computer.

Computer Demystification

As computer use, terminology and understanding become more widespread, the general public's perceptions of computers will change. It has always been popular for shipping and billing clerks to blame the computer when customers complained. The computer has been the scapegoat for so long the consumer believes the machines to be inept. There is a good chance the idiot jokes of the

1950's, the moron jokes of the 1970's and ethnic jokes of the present will evolve to: "How many computers are needed to change a lightbulb?"

Hopefully, the increasing influence of the home computer will alter those perceptions. Computers do not make mistakes. Electricity is either on or off to a bit. Mistakes are made by programmers, analysts, key-punchers and operators. That loan payment, never credited to your account, was not the prank of a vengeful computer, but of a careless clerk. When the general public is aware of this, our industry will be better understood.

Another harmful myth claims increased automation will increase unemployment. The world's most automated country, Japan, suffers an unemployment rate of only two percent. In addition, the Japanese worker expresses a higher satisfaction than his American counterpart. The computer is normally used to free humans from mundane and repetitious tasks.

Managers and business executives often express dissatisfaction with their computers and technicians. Usually these disappointments are the result of three misconceptions. Many users have, initially, too great an expectation for their new computerized projects. Often, these expectations are unrealistic, sometimes caused by an over-zealous computer salesman. Some management see computers as a cure-all for their business problems when, in fact, a computer may aggravate some problems it was purchased to solve.

By far, the greatest reason for dissatisfaction with a computer system stems from inadequate system development. The system development process encompasses all the actions necessary to create a computer application from the problem development stage through user acceptance. In Part III we will begin to examine the entire system development process—in theory and in practice. ■

FREE EPSON MX-80 PRINTER

With the purchase of a TRS 80, Model III.

For a limited time, Data Services, Inc., will give you a FREE Epson MX-80 Printer (\$645 value), when you buy a TRS 80 Model III, 48k, with 2 PERCOM 40 track drives, at a regular price of \$2,495.

(Optional RS 232. \$90 extra. Radio Shack w/RS 232 - \$170 extra. Printer cable - add \$35.00)

The perfect system, the perfect price!
TRS 80 Model III, 48k - two PERCOM 40 track drives - EPSON MX-80 Printer.

Data Services offers more — APPARAT'S NEWDOS 80, version VER 2.0, regularly \$149.95 — now only \$129.95

Up to 20% savings on TRS computers — accessories — programs, Plus: EPSON / PERCOM / APPARAT / HAYES SMARTMODEM / VERBATIM DISKETTES.

*TRS-80 is a trademark of Tandy Corporation.



- FREE SHIPPING in 48 contiguous states.
- No Sales Tax on out-of-state orders.
- Visa/Master Card welcome.
- Personal checks, allow 3 weeks to clear.
- (International orders, freight F.O.B. Wichita, Kansas)

CALL TOLL FREE: 1-800-835-1129
or order by mail from:

DATA SERVICES, INC.

COMPUTER SERVICES SINCE 1970

P.O. Box 1157 Wichita, Kansas 67201-1157
(In Kansas, call 1-316-838-9021)

PROFESSIONAL



INCOME TAX SYSTEM

FOR TRS-80* MODEL I, II or III

For five successive years!

Our system, running on the magnificent line of TRS-80 computers, has prepared thousands of lightning-fast, error-free tax returns a day in accounting offices worldwide.

Now we introduce!

SYSTEM THREE!

SYSTEM THREE is an improved, still more interactive version — Totals W-2's and computes FICA overpayment — Includes "QWIKTAX," a fast tax calculator for tax planning — Has automated Client Billing — More!

And, as always—

1. Full interactive user control, in tax-form language only, line-by-line.
2. Screen display of full 1040 and all schedules, prior to printout.
3. All formats IRS and State approved.
4. Schedule amounts automatically entered on Form 1040.
5. Your Preparer's Information automatically printed at bottom of Page 2, Form 1040.
6. Built-in Validation Check tests entire system, hardware and software.
7. Special printer adjustment routines: Margin Offset, Text Position, etc.
8. Fills in pre-printed forms (we supply) or use overlays. Your choice.
9. **AUTOMATICALLY COMPUTES:** Tax — Earned Income Credit — Maximum/Minimum Tax — Least Tax Method — All Percentage of Income Limitations — All Fixed Limitations.
DOES INCOME AVERAGING IN EIGHT SECONDS!
10. Full support through the tax season, no charge.
11. Inexpensive yearly updates in accordance with tax-law changes.

SYSTEM THREE comes in four modules. You select the ones you need. There is no system like it, for any computer, and the cost is literally nothing. In one season, our users have paid, out of savings, for the software **and the computer.**

45-page Descriptive Manual - \$7.50

(Refundable on order)

MINIMUM SYSTEM REQUIRED: Model I, 48K, 1 Disk Drive

CONTRACT SERVICES ASSOCIATES
706 SOUTH EUCLID • ANAHEIM, CA 92802 • TELEPHONE: (714) 635-4055

*TRS-80 is a trademark of Tandy Corp.

TAXPLAN!

Income Tax Planning System
including
Five-Year Tax Computations!
(1981 thru 1985)

The only fully comprehensive Tax-Estimating system ever offered. Used by accountants, attorneys, tax preparers, businessmen, investors, realtors, loan companies.

Income-Averaging Minimum/Maximum Tax Computations

Enter or change figures in 30 seconds. Print out statements. Plan your tax strategy for five years ahead. (Does not prepare returns for filing.)

For TRS-80 Models I, II, & III **\$249.95**

(\$149.95 to registered users of our Tax System)
Requires 48K & 1 disk drive

FROM THE WORLD LEADER IN INCOME TAX SOFTWARE:

CONTRACT SERVICES ASSOCIATES
706 SOUTH EUCLID • ANAHEIM, CA 92802 • TELEPHONE: (714) 635-4055

*TRS 80 is a trademark of Tandy Corp.

—68



Make your 80 a crooning computer.

Micro Melodies

Kenneth Lee Gibbs
31 Willow Street
Highspire, PA 17034

Name That Song is a delightful sound and action game pitting one to four contestants against one another to determine who can identify the most folk songs. It has been one of the most popular games in our household since I completed it.

I modified David G. Morr's machine language routine (*80 Microcomputing*, May 1980), which was set up to produce random

sounds, to make it suitable for producing music.

Teaching the TRS-80 to Sing

You must begin by giving your computer singing lessons. You do this by POKEing a small machine language program into memory via Basic. Lines 40-60 in Program Listing 1 contain all the instructions your 80 needs. The same instructions appear in line 5 of Program Listing 2.

Whenever you use this routine answer the memory size? question with 32737. This protects the last 29 bytes of RAM for the machine language routine and prevents the rest of the program from bumping into that area of memory. With this routine your TRS-80 can make 32768 different noises, ranging from sounds so high and fast that you cannot hear them, to long low rumbles.

There are 256 different tones, each of which can be produced for 128 different durations. These durations range from

about seven milliseconds to about 1 3/4 seconds.

Sifting Music from Noises

Which tones and durations should you use to produce music? I will share these secrets with you. Table 1 shows the total range of the musical tones the TRS-80 can sing.

There are lower, higher, and tones in between each of the notes listed. However, these other tones are not within our field of interest because they do not constitute music.

For the most part you will never need most of the notes in the list. Name That Song has parts of 37 songs and I never used a note lower than low A# nor one higher than high E.

The numbers in Table 2 represent the various durations of notes and rests used in rather snappy 4/4 time and 3/4 time. You can change these values to suit your own tastes in musical

tempos. However, any number you use as a duration should produce an integer when divided by 256, otherwise you will be affecting the pitch as well as the duration.

Zero is the longest duration and it is twice as long as the next longest which is 32512, creating some problems. Notice that I did not list anything for the duration of a dotted half note in 4/4 time. There is no duration between the half and the whole note when the whole note is duration zero. To get around this problem I changed any dotted half notes into half notes and added a quarter rest. In most songs this is hardly noticed.

When making computer music, always define all variables as integers. This saves bytes, speeds up execution, and also prevents you from sending information to the machine language routine that cannot be used.

The numbers given in Table 2

The Key Box

Basic Level II
Model I
16K RAM
Amplifier required

```
Set MEMORY SIZE? to 32737
10 REM THIS PROGRAM PLAYS A MUSICAL SCALE
20 REM AT VARIOUS SPEEDS - DEMONSTRATION ONLY
30 CLS : DEFINIT A-Z : Q = 24576
40 POKE 16527,127 : POKE 16526,226
50 FOR N = 32738 TO 32766 : READ X : POKE N,X : NEXT
60 DATA 205, 127, 10, 62, 1, 14, 0, 237, 91, 61, 64, 69, 47, 230, 3, 179, 211, 255,
    13, 40, 4, 16, 246, 24, 242, 37, 32, 241, 201
70 FOR T = 1 TO 5
80 Z = USR(145 + Q) : Z = USR(129 + Q) : Z = USR(115 + Q)
90 Z = USR(108 + Q) : Z = USR(97 + Q) : Z = USR(86 + Q)
100 Z = USR(77 + Q) : Z = USR(73 + Q) : Z = USR(77 + Q)
110 Z = USR(86 + Q) : Z = USR(97 + Q) : Z = USR(108 + Q)
120 Z = USR(115 + Q) : Z = USR(129 + Q) : Z = USR(145 + Q)
130 Q = Q/2
140 NEXT
150 RUN
```

Program Listing 1

Note	Pitch Value(P)	Note	Pitch Value(P)
Low D#	244	A#	81
Low E	230	B	77
Low F	216	High C	73
Low F#	204	High C#	68
Low G	194	High D	65
Low G#	184	High D#	61
Low A	172	High E	58
Low A#	162	High F	54
Low B	155	High F#	51
C	145	High G	48
C#	135	High G#	46
D	129	High A	43
D#	122	High A#	41
E	115	High B	38
F	108	Very High C	36
F#	102	Very High C#	34
G	97	Very High D	32
G#	92	Very High D#	30
A	86		

Table 1. Pitch Values

for rests are also only valid if you define the variable used in the For...Next loop as an integer.

Let's Make Music

Plug the auxiliary cable into

your Archer Mini-Amplifier or Realistic Micro-Sonic and turn it on. To play a note make a USR call to the sound routine using an unused variable. Define it as equaling the USR call. For example, Z=USR(0) would be a

proper method. The number in parentheses is the sum of the pitch value (P) and the duration value (D). I put the pitch value and the duration value in the parentheses along with a plus sign and let the computer do the work of adding them; Z = USR(P + D).

The statement for playing high D note with a quarter note duration in 3/4 time, would read: Z = USR(65 + 10752).

When the computer encounters this statement it goes to the music routine and executes a high D quarter note. It then returns to the next statement in the list.

To insert a musical rest (silence) between notes insert a For...Next timing loop between the USR calls. Refer to Table 2 for the proper length of the loops for the duration of the desired rest. ■

Program Listing 2

```

0 NAME THAT POLK SONG BY KENNETH LEE GIBBS 10/12/81
5 CLEAR278:CLS:DEFINFA-Z:DIMNS(36):POKE16527,127:POKE16526,226:FORN1=32738T
032766:READL1:POKEN1,X1:NEXT:DATA295,127,10,62,1,14,9,237,91,61,64,69,47,23
0,3,179,211,255,13,40,4,16,246,24,242,37,32,241,201:RANDOM:K9=1:TT=0
6 H=162:I=155:C=145:J=135:D=129:E=115:F=108:K=102:L=97:M=92:N=81:B=77:
N=73:O=65:P=32512:Q=24576:R=21768:S=16384:T=12288:U=10752:V=8192:W=5376:X=4
996:FORV1=1TO36:NS(V1)=V1:NEXT:GOTO10
7 IFK9=1RETURN
8 Y=Y-1:PRINT#930,Y;:IN$=INKEY$:IFIN$<>"*THEN300
9 RETURN
10 PRINTCHR$(23):PRINT#262,"?1? NAME THAT SONG ?1?:PRINT#536,"( #1 )":PR
INT#700,"-":;:-- FOLK SONGS --:;:--:RT=RND(4):ONRTGOSUB45000,33000,44000,1
4000
11 CLS:INPUT"HOW MANY CONTESTANTS ( 1 TO 4 )";NC:IF(NC<1)OR(NC>4)THEN11
12 CLS:INPUT"FIRST PLAYER'S NAME";P1$:PRINTP1$;" YOUR BUZZER IS THE < Q >
KEY":IFNC=1GOTO20
14 PRINT:INPUT"SECOND PLAYER'S NAME";P2$:PRINTP2$;" YOUR BUZZER IS THE < P >
KEY":IFNC=2GOTO20
16 PRINT:INPUT"THIRD PLAYER'S NAME";P3$:PRINTP3$;" YOUR BUZZER IS THE < C >
KEY":IFNC=3GOTO20
18 PRINT:INPUT"FOURTH PLAYER'S NAME";P4$:PRINTP4$;" YOUR BUZZER IS THE < M >
KEY"
19 IFLEN(P1$)+LEN(P2$)+LEN(P3$)+LEN(P4$)>140THEN12
22 NS=10:PRINT"*****"
23 PRINT** PRESS YOUR BUZZER KEY WHEN YOU THINK YOU KNOW THE SONG. **
25 PRINT** YOU LOSE 33% OF YOUR POINTS IF YOU GUESS WRONG! **
26 PRINT** DON'T USE NUMBERS IN YOUR GUESS. USE ONLY 1 SPACE BETWEEN **
28 PRINT** WORDS. DON'T USE ANY COMMAS! ";:INPUT"PRESS <ENTER> TO START
";DU
50 TT=TT+1:CLS:PRINTP1$;" HAS";P1;"POINTS < Q >";IFNC<2GOTO60
52 PRINT:PRINTP2$;" HAS";P2;"POINTS < P >";IFNC<3GOTO60
54 PRINT:PRINTP3$;" HAS";P3;"POINTS < C >";IFNC<4GOTO60
56 PRINT:PRINTP4$;" HAS";P4;"POINTS < M >";
60 PRINT:PRINT"SONGS LEFT IN THIS GAME";NS
63 IFTT>36THENPRINT"NO MORE SONGS...YOU NEED PRACTICE!";GOTO60000
65 IFNS=#GOTO60000
70 PRINT:INPUT"PRESS <ENTER> TO START SONG";SS
75 Y=RND(18)+32:K9=0
77 PRINT#915,"THIS SONG WORTH";Y;"POINTS"
80 PORT1=1TORND(999)+999:NEXT
90 RN=RND(36)
92 IFNS(RN)=#GOTO90
94 NS(RN)=#
99 IFY<32THENY=32
100 ONRANGOSUB10000,11000,12000,13000,14000,15000,16000,17000,18000,19000,20
000,21000,22000,23000,24000,25000,26000,27000,28000,29000,30000,31000,32000
,33000,34000,35000,36000,37000,38000,39000,40000,41000,42000,43000,44000,45
000
105 IPK9=1GOTO50
110 CLS:PORT1=1TO555:NEXT:PRINT#154,"TOO BAD !";GOSUB52000:PRINT#727-LEN(C$
)/2,"THAT SONG WAS: ";C$:NS=NS-1:PORT1=1TO40000:NEXT:CLS:GOTO50
300 FORN1=1TO7:Z=USR(5150)+USR(5240):NEXT
302 IFNS="Q"THEN400
303 IFNC=2THEN500
304 IFNS="P"THEN500
305 IFNC=3THEN900
306 IFNS="C"THEN600
307 IFNC=4THEN900
308 IFNS="M"THEN700
310 GOTO900
400 CLS:PRINT#440,"OK, ";P1$;"...FOR";Y;"POINTS..."
405 PRINT:INPUT"NAME THAT SONG ????";X$:IFLEN(X$)>55THEN405ELSEGOSUB50000
410 IF11=#THEN444
415 CLS:PRINT#535,"THAT IS CORRECT!";GOSUB51000:CLS:P1=P1+Y:NS=NS-1:K9=1:PR
INT#544-LEN(C$)/2,C$:GOTO100
444 CLS:PRINT#540,"WRONG!";GOSUB52000:CLS:P1=INT(P1-1/3):GOTO50
500 CLS:PRINT#440,"OK, ";P2$;"...FOR";Y;"POINTS..."
505 PRINT:INPUT"NAME THAT SONG ????";X$:IFLEN(X$)>55THEN505ELSEGOSUB50000
510 IF11=#THEN544
515 CLS:PRINT#535,"THAT IS CORRECT!";GOSUB51000:CLS:P2=P2+Y:NS=NS-1:K9=1:PR
INT#544-LEN(C$)/2,C$:GOTO100
544 CLS:PRINT#540,"WRONG!";GOSUB52000:CLS:P2=INT(P2-2/3):GOTO50
600 CLS:PRINT#440,"OK, ";P3$;"...FOR";Y;"POINTS..."
605 PRINT:INPUT"NAME THAT SONG ????";X$:IFLEN(X$)>55THEN605ELSEGOSUB50000
610 IF11=#THEN644
615 CLS:PRINT#535,"THAT IS CORRECT!";GOSUB51000:CLS:P3=P3+Y:NS=NS-1:K9=1:PR
INT#544-LEN(C$)/2,C$:GOTO100
644 CLS:PRINT#540,"WRONG!";GOSUB52000:CLS:P3=INT(P3-3/3):GOTO50
700 CLS:PRINT#440,"OK, ";P4$;"...FOR";Y;"POINTS..."
705 PRINT:INPUT"NAME THAT SONG ????";X$:IFLEN(X$)>55THEN705ELSEGOSUB50000
710 IF11=#THEN744
715 CLS:PRINT#535,"THAT IS CORRECT!";GOSUB51000:CLS:P4=P4+Y:NS=NS-1:K9=1:PR
INT#544-LEN(C$)/2,C$:GOTO100
744 CLS:PRINT#540,"WRONG!";GOSUB52000:CLS:P4=INT(P4-4/3):GOTO50
900 CLS:PRINT#518,"SOMEONE DIDN'T USE THE RIGHT KEY FOR THEIR BUZZER!";PORT
1=1TO2222:NEXT:CLS:PRINT#915,"THIS SONG WORTH";Y;"POINTS";GOTO99
10000 C$="L'IL LIZ JANE":Y$="LIZ JANE"
10010 Z=USR(N+S):Y=Y+1:GOSUB7:Z=USR(G+V):GOSUB7:Z=USR(A+S):GOSUB7:Z=USR(G+S
):GOSUB7:Z=USR(A+V):GOSUB7:Z=USR(G+S):GOSUB7:Z=USR(E+V):GOSUB7:Z=USR(G+P):G
OSUB7:Z=USR(N+S):GOSUB7
10020 Z=USR(G+V):GOSUB7:Z=USR(A+S):GOSUB7:Z=USR(G+S):GOSUB7:Z=USR(E+V):GOSU
B7:Z=USR(E+S):GOSUB7:Z=USR(D+V):GOSUB7:Z=USR(C+P):GOSUB7:RETURN
11000 C$="BLACK IS THE COLOR OF MY TRUE LOVE'S HAIR":Y$="BLACK IS THE COLOR
"
11010 Z=USR(E+P):Y=Y+1:GOSUB7:Z=USR(G+P):GOSUB7:Z=USR(B+P):GOSUB7:Z=USR(A+S
):GOSUB7:Z=USR(B+S):GOSUB7:Z=USR(E+S):GOSUB7:Z=USR(E+S):GOSUB7
11020 Z=USR(D+S):GOSUB7:Z=USR(E+S):GOSUB7:Z=USR(K+P):GOSUB7:Z=USR(D+P):GOSU
B7:Z=USR(G):GOSUB7:RETURN
12000 C$="AURA LEE":Y$=C$
12010 Z=USR(F+S):Y=Y+1:GOSUB7:Z=USR(M+S):GOSUB7:Z=USR(A+S):GOSUB7:Z=USR(M+S
):GOSUB7:Z=USR(N+S):GOSUB7:Z=USR(G+S):GOSUB7:Z=USR(N+Q):GOSUB7:PORT1=1TO182
:NEXT:Z=USR(N+V):GOSUB7
12020 Z=USR(N+S):GOSUB7:Z=USR(A+S):GOSUB7:Z=USR(G+S):GOSUB7:Z=USR(A+S):GOSU
B7:Z=USR(M+P):GOSUB7:Z=USR(P+P):GOSUB7:RETURN
13000 C$="ON TOP OF OLD SMOKEY":Y$=C$
13010 Z=USR(C+U):Y=Y+1:GOSUB7:Z=USR(C+U):GOSUB7:Z=USR(E+U):GOSUB7:Z=USR(G+U
):GOSUB7:Z=USR(N+P):GOSUB7:Z=USR(A+P):GOSUB7:Z=USR(A+U):GOSUB7
13020 Z=USR(P+U):GOSUB7:Z=USR(G+U):GOSUB7:Z=USR(A+U):GOSUB7:Z=USR(G):GOSUB7

```

Program Listing 2 Continues

4/4 Time 3/4 Time

Duration	Note(D)	Rest*	Note(D)	Rest*
2 Tied dotted halves	—	—	Zero	1455
Whole note	Zero	1455	—	—
Dotted half	—	—	32512	728
Half note	32512	728	21760	485
Dotted quarter	24576	546	18384	364
Quarter note	18384	364	10752	242
Dotted eighth	12288	273	8192	182
Eighth note	8192	182	5376	121
Sixteenth note	4096	91	2560	61

*Use the value in the column to create a rest between notes. These values are to be used in integer For...Next loops. Example: To execute a quarter rest in 4/4 time (where X has been defined as an integer), the line would read: FOR X = 1 TO 364 : NEXT

Table 2. Duration Values

"DOS RANDOM ACCESS & BASIC FILE HANDLING"

DSC Publishing
2 Dogwood Drive
PO Box 769
Danbury, CT 06810
Phone Order
(203) 748-3231



the HOW TO, SHOW & TELL, STEP by STEP book. Written for TRS-80 and all computers using Microsoft basic. The breakthrough book for non-programmers... businessmen and professionals who want to solve in house problems by writing your own customized program... and the hobbyist with the desire to get beyond the cassette and into disk data storage and file manipulation. "DOS Random Access & File Handling" is the plain speaking, easy to read 150 page book for learning HOW TO WRITE SPECIAL PROGRAMS for inventories, mailing lists, work schedules, record keeping and more. Your acquaintance with Level I and Level II basic and this self-instruction tutorial will assure quick progress.

Yes, I want to expand my programming knowledge. I have Model I or III Model II

Please send me a copy of "DOS Random Access & File Handling" for \$29.50 & \$1.50 shipping Model II \$1.50 extra

Also send me the compatible program disk for 28.50 + 1.50 shipping Model II 32.50 + 1.50

Overseas add 8.00 per book and disk airmail.

Name _____
Address _____
City _____
State _____ Zip _____
Master Charge VISA
Expiration Date _____
Card # _____
Check Money Order
COD (2.00 extra)
Signature _____

"Dealer Inquiries Invited" Phone Orders (203) 748-3231 CT. orders add 7.5% sales tax.

EXCITING NEWS FOR COLOR COMPUTER USERS

FLEX, OS-9 and the Radio Shack Disk System ALL on the SAME Color Computer

Would you believe that you can run FLEX, OS-9 and Radio Shack disk software on the same Color Computer, and all you have to do is change the disk? That's right; just change the disk - you have a 32K Color Computer with the Radio Shack disk system, all you need to do is make a trivial modification to access the hidden 32K as described in the Feb issue of COLOR COMPUTER NEWS and the April issue of '88 Micro. You can get FLEX from us right now. OS-9 will be ready by summer. Please note that this will only work with the Radio Shack disk system and 32K/64K memory chips that RS calls 32K. Maybe they put 64K's in yours too. If you don't have a copy of the article, send a legal size SASE, 10cc stamp and we'll send it to you.

Using this system to run FLEX and OS-9 has many advantages. First, it saves you 48K from zero right up to FLEX. This means that ALL FLEX compat disk software will run with NO MODIFICATIONS and NO PATCHES! There are no memory conflicts because we moved the screen up above FLEX which leaves the lower 48K free for user programs.

What you end up with is 48K for user programs, 8K for FLEX and another 8K above FLEX for the screen, and stuff. We have a multi-screen format so you can page backward to see what's scrolled by and a HiRes screen that will enable us to have 24 lines by 42 character display is on the way. That's better than an Apple!

We also implemented a full function keyboard, with a control key and escape key. All ASCII codes can now be generated from the Color Computer keyboard!

We also added some bells and whistles to Radio Shack's Disk system when you're running FLEX or OS-9. We are supporting single or double sided, single or double density, 35, 40 and 80 track drives. If you use double sided drives (the maximum is three drives because we use the drive select for side select). When you are running the Radio Shack disk, it will work with the double sided drives but I will only use one side and only 35 tracks. Using 80 track drives is okay but will not be compatible with standard Radio Shack software. You can also set each drive's stepping rate and drive type (SS or DS SD or DI).

In case you don't understand how this works, I'll give you a brief explanation. The Color Computer was designed so that the roms in the system could be turned off under software control. In a normal Color Computer this would only make it go away. However if you put a program in memory to do something first (like boot in FLEX or OS-9), when you turn off the roms you will have a full RAM System with which to run your program (FLEX or OS-9). When the roms are turned off, it is as if you had removed them from the computer. They are gone!

New, we need the other half of the 64K ram chips to work, and this seems to be the case most of the time, as the other 64K chips, of course, you could also put 64K chips in.

Some new utilities are included:

MOVEMOV moves Color Basic from ROM to RAM. Because it's moved to RAM you can not only access it from FLEX, you can run it and even change it! You can load Color Computer cassette software and save it to FLEX disk. Single Dr. Copy, Format and Setup commands are also included.

Installing FLEX is simple. Insert the disk and type:

RUN "FLEX"

That's all there is to it! You are now up and running in the most popular operating system for the 8009. There are hundreds of software packages now running under the FLEX system. Open your Color Computer to a whole new world of software with FLEX.

FLEX \$99.00 NEW LOW PRICE INCLUDES OVER 25 UTILITIES!

- FLEX Editor \$ 50.00
- FLEX Assembler \$ 50.00
- FLEX Standard BASIC \$ 65.00
- FLEX Extended Business BASIC \$100.00
- Other languages available include, FORTH, Pascal, Fortran-77, C, plus more.
- Application packages include, A/R, G/L, A/P, Inventory, Electronic Spreadsheets, Accounting, Database programs and more. SEND FOR LIST!
- TRS 80 COLOR COMPUTER COMPLETE WITH 64K RAM 24K ROM, SINGLE DISK DRIVE AND FLEX, SET UP AND READY TO RUN FOR ONLY \$1,375. Includes 60 day extended warranty. If you have a Computer, call about RS disk controllers and drives.

FRANK HOGG LABORATORY, INC.

130 MIDTOWN PLAZA • SYRACUSE NEW YORK 13210 • (315)474-7656

✓262

Computers & Gambling Products Magazine

SEND FOR FREE CATALOG

Beat Roulette with a Pocket Computer!
This booklet by Dr. Edward O. Thorp describes his little known work on Physical Prediction of Roulette. The man who made Las Vegas change the rules on Blackjack exposes Roulette's susceptibility to computers. \$ 9.95

Horse Race Handicapping! Our biggest seller - Probability Handicapping Device-1. This is a comprehensive horse racing system for spotting overlays in thoroughbred sprint races. Easy entry of data from the racing form. A complete user's manual takes you step by step through a sample race and explains overlay betting and money management. The user's manual contains a detailed lab run of a 100 consecutive race system workout showing an amazing \$1.50 returned for each \$1.00 wagered. (Note: this is not the same program as "Winning at the Races"). You may purchase the manual separately for \$7.95 and credit PHD-1 is now available for CP/M (Basic-80, M-Basic), PHD-1 User's Manual and cassette for: 16K Apple II AppleSoft, 8K Ohio Scientific (specify 1P or 4P), 16K TRS-80 Model I or III... \$29.95
Apple or TRS-80 Disk \$34.95
CP/M 8" Single Density Data Disk \$39.95

DR. QUIRIN'S FAMOUS DISCOVERIES!
Win at the Races. This is the program using the algorithms from Dr. Quirin's book. Highly praised and endorsed by DR QUIRIN, this program is the best available today. Screen edit data entry makes entering data a breeze. Dr. Quirin's par time adjustment routines are included. We warned you that the price would go up and it did. Order now because this price will go up again. \$49.95
Winning at the Races Cassette (32K TRS-80 or Apple) Disk \$49.95

Winning at the Races - the book by William Quirin Ph.D. This is the best computerized study of thoroughbred racing ever published. This 300 page hardbound book shows detailed studies of high impact value factors and includes Dr. Quirin's famous Par Times \$21.95
A Tom Ainsie Winners Circle Book

Beating the Races with a Computer by Steve Brecher. A good "How To" book on multiple regression techniques applied to Pari-Mutua handicapping. Some heavy math \$14.95

Make checks payable to JOE COMPUTER - Phone orders and information (212) 982-0514
Send to JOE COMPUTER 22713 Ventura Blvd. Suite F, Woodland Hills, CA 91364
California residents add 6 1/2% sales tax
© 1988 Joe Computer. All Rights Reserved. 

Program Listing 2 Continued

```

:RETURN
14000 C$="THE HOUSE OF THE RISING SUN";Y$="HOUSE OF THE RISIN"
14010 Z=USR(A+U);Y=Y+1;GOSUB7;Z=USR(D+R);GOSUB7;Z=USR(E+W);GOSUB7;Z=USR(D+W)
:GOSUB7;Z=USR(F+R);GOSUB7;Z=USR(G+W);GOSUB7;Z=USR(L+W);GOSUB7
14020 Z=USR(A+R);GOSUB7;Z=USR(F+W);GOSUB7;Z=USR(E+W);GOSUB7;Z=USR(D+R);GOSUB7
:Z=USR(B+U);GOSUB7;Z=USR(O+R);GOSUB7;Z=USR(A+U);GOSUB7
14030 Z=USR(N+R);GOSUB7;Z=USR(A+W);GOSUB7;Z=USR(G+W);GOSUB7;Z=USR(A);GOSUB7
:RETURN
15000 C$="WILDWOOD FLOWER";Y$=C$
15010 Z=USR(E+S);Y=Y+1;GOSUB7;Z=USR(F+S);GOSUB7;Z=USR(G+P);GOSUB7;Z=USR(A+S)
:GOSUB7;Z=USR(N+S);GOSUB7;Z=USR(E+P);GOSUB7;Z=USR(F+S);GOSUB7;Z=USR(E+S);GOSUB7
:Z=USR(D+P);GOSUB7
15020 Z=USR(E+S);GOSUB7;Z=USR(D+S);GOSUB7;Z=USR(C+P);GOSUB7;Z=USR(E+S);GOSUB7
:RETURN
16000 C$="I'VE BEEN WORKING ON THE RAILROAD";Y$="ON THE RAILRO"
16010 Z=USR(G+Q);Y=Y+1;GOSUB7;Z=USR(D+V);GOSUB7;Z=USR(G+T);GOSUB7;Z=USR(D+X)
:GOSUB7;Z=USR(G+T);GOSUB7;Z=USR(A+X);GOSUB7;Z=USR(B+P);GOSUB7;Z=USR(G+P);GOSUB7
:Z=USR(N+Q);GOSUB7
16020 Z=USR(N+V);GOSUB7;Z=USR(G+S);GOSUB7;Z=USR(A+S);GOSUB7;Z=USR(B);GOSUB7
:RETURN
17000 C$="SIXTEEN TONS";Y$=C$
17010 Z=USR(I+V);Y=Y+1;GOSUB7;Z=USR(I+S);GOSUB7;Z=USR(E+S);GOSUB7;Z=USR(E+S)
:GOSUB7;Z=USR(E+Q);GOSUB7;Z=USR(E+V);GOSUB7;Z=USR(G+V);GOSUB7;Z=USR(G+V);GOSUB7
:Z=USR(E+V);GOSUB7
17020 Z=USR(K+P);GOSUB7;Z=USR(E+V);GOSUB7;Z=USR(G+V);GOSUB7;Z=USR(A+S);GOSUB7
:Z=USR(E+V);GOSUB7;Z=USR(E+S);GOSUB7;Z=USR(E+V);GOSUB7;Z=USR(A+S);GOSUB7
17030 Z=USR(E+V);GOSUB7;Z=USR(K+P);GOSUB7;Z=USR(E+V);GOSUB7;Z=USR(D+Q);GOSUB7
:RETURN
18000 C$="FRANKIE AND JOHNNY";Y$="AND JO"
18010 Z=USR(C+V);Y=Y+1;GOSUB7;Z=USR(D+V);GOSUB7;Z=USR(E+V);GOSUB7;Z=USR(A+S)
:GOSUB7;Z=USR(G+V);GOSUB7;Z=USR(E+S);GOSUB7;Z=USR(C+S);GOSUB7;Z=USR(C+P);GOSUB7
:Z=USR(C+V);GOSUB7
18020 Z=USR(D+V);GOSUB7;Z=USR(E+V);GOSUB7;Z=USR(A+S);GOSUB7;Z=USR(G+V);GOSUB7
:Z=USR(E+V);GOSUB7;Z=USR(C+P);GOSUB7;Z=USR(E+V);GOSUB7;Z=USR(A+S);GOSUB7
:RETURN
19000 C$="TOM DOOLEY";Y$=C$
19010 Z=USR(D+P);Y=Y+1;GOSUB7;Z=USR(D+S);GOSUB7;Z=USR(D+S);GOSUB7;Z=USR(E+P)
:GOSUB7;Z=USR(G+P);GOSUB7;Z=USR(B+P);GOSUB7;Z=USR(B);GOSUB7;Z=USR(D+P);GOSUB7
:Z=USR(G+P);GOSUB7
19020 Z=USR(D+S);GOSUB7;Z=USR(D+S);GOSUB7;Z=USR(E+P);GOSUB7;Z=USR(G+P);GOSUB7
:Z=USR(A);GOSUB7;RETURN
20000 C$="BILLY BOY";Y$=C$
20010 Z=USR(E+V);Y=Y+1;GOSUB7;Z=USR(F+V);GOSUB7;Z=USR(G+S);GOSUB7;Z=USR(G+V)
:GOSUB7;Z=USR(G+V);GOSUB7;Z=USR(N+S);GOSUB7;Z=USR(E+V);GOSUB7;Z=USR(F+V);GOSUB7
:Z=USR(G+V);GOSUB7
20020 Z=USR(G+V);GOSUB7;Z=USR(A+V);GOSUB7;Z=USR(G+S);GOSUB7;Z=USR(E+V);GOSUB7
:Z=USR(N+S);GOSUB7;Z=USR(G+V);GOSUB7;Z=USR(G+S);GOSUB7;Z=USR(G+V);GOSUB7;Z=USR(G+V);GOSUB7
:Z=USR(N+S);GOSUB7
20030 Z=USR(F+V);GOSUB7;Z=USR(E+V);GOSUB7;Z=USR(E+V);GOSUB7;Z=USR(D+Q);GOSUB7
:RETURN
21000 C$="HOME ON THE RANGE";Y$=C$
21010 Z=USR(D+S);Y=Y+1;GOSUB7;Z=USR(D+S);GOSUB7;Z=USR(G+S);GOSUB7;Z=USR(A+S)
:GOSUB7;Z=USR(B+R);GOSUB7;Z=USR(G+W);GOSUB7;Z=USR(K+W);GOSUB7;Z=USR(E+S);GOSUB7
:Z=USR(N+S);GOSUB7
21020 Z=USR(N+S);GOSUB7;Z=USR(N+R);GOSUB7;Z=USR(N+W);GOSUB7;Z=USR(N+W);GOSUB7
:Z=USR(O+R);GOSUB7;Z=USR(G+W);GOSUB7;Z=USR(G+W);GOSUB7;Z=USR(G+S);GOSUB7
:Z=USR(E+V);GOSUB7;Z=USR(G+S);GOSUB7;Z=USR(O+S);GOSUB7;Z=USR(A);GOSUB7;RETURN
22000 C$="HUSH LITTLE BABY";Y$=C$
22010 Z=USR(D+S);Y=Y+1;GOSUB7;Z=USR(B+V);GOSUB7;Z=USR(B+V);GOSUB7;Z=USR(B+S)
:GOSUB7;Z=USR(B+S);GOSUB7;Z=USR(B+S);GOSUB7;Z=USR(A+S);GOSUB7;Z=USR(A+P);GOSUB7
:Z=USR(D+V);GOSUB7
22020 Z=USR(D+V);GOSUB7;Z=USR(A+V);GOSUB7;Z=USR(A+V);GOSUB7;Z=USR(A+V);GOSUB7
:Z=USR(A+S);GOSUB7;Z=USR(B+V);GOSUB7;Z=USR(A+S);GOSUB7;Z=USR(G+S);GOSUB7;Z=USR(G+Q);GOSUB7
:RETURN
23000 C$="MICHAEL ROW THE BOAT ASHORE";Y$="MICHAEL"
23010 Z=USR(C+V);Y=Y+1;GOSUB7;Z=USR(E+S);GOSUB7;Z=USR(G+P);GOSUB7;Z=USR(E+V)
:GOSUB7;Z=USR(G+S);GOSUB7;Z=USR(A+S);GOSUB7
23020 Z=USR(G+P);GOSUB7;Z=USR(E+S);GOSUB7;Z=USR(G+S);GOSUB7;Z=USR(A);GOSUB7
:Z=USR(G+P);GOSUB7;RETURN
24000 C$="WHEN THE SAINTS GO MARCHING IN";Y$="WHEN THE SAINTS"
24010 Z=USR(C+V);Y=Y+1;GOSUB7;Z=USR(A+V);GOSUB7;Z=USR(M+V);GOSUB7;Z=USR(N+P)
:GOSUB7;PORT1=170182;NEXT;Z=USR(F+V);GOSUB7;Z=USR(A+V);GOSUB7;Z=USR(N+P);GOSUB7
:Z=USR(N+P);GOSUB7;PORT1=170182;NEXT
24020 Z=USR(F+V);GOSUB7;Z=USR(A+V);GOSUB7;Z=USR(M+V);GOSUB7;Z=USR(M+S);GOSUB7
:Z=USR(A+S);GOSUB7;Z=USR(F+S);GOSUB7;Z=USR(A+S);GOSUB7;Z=USR(G+P);GOSUB7;RETURN
25000 C$="THE WABASO CANNON BALL";Y$="WABASO CANNON"
25010 Z=USR(D+V);Y=Y+1;GOSUB7;Z=USR(D+V);GOSUB7;Z=USR(D+S);GOSUB7;Z=USR(D+S)
:GOSUB7;Z=USR(G+S);GOSUB7;Z=USR(A+S);GOSUB7;Z=USR(B+S);GOSUB7;Z=USR(O+P);GOSUB7
:Z=USR(G+V);GOSUB7
25020 Z=USR(G+V);GOSUB7;Z=USR(B+S);GOSUB7;Z=USR(G+V);GOSUB7;Z=USR(G+S);GOSUB7
:Z=USR(E+S);GOSUB7;Z=USR(C);GOSUB7;RETURN
26000 C$="I GAVE MY LOVE A CERRY";Y$=C$
26010 Z=USR(C+S);Y=Y+1;GOSUB7;Z=USR(C+P);GOSUB7;Z=USR(C+S);GOSUB7;Z=USR(C+P)
:GOSUB7;Z=USR(C+S);GOSUB7;Z=USR(D+P);GOSUB7;Z=USR(F);GOSUB7;Z=USR(G+P);GOSUB7
:Z=USR(F);GOSUB7
26020 Z=USR(D+P);GOSUB7;Z=USR(C);GOSUB7;PORT1=170364;NEXT;Z=USR(F+S);GOSUB7
:Z=USR(G+P);GOSUB7;Z=USR(G+S);GOSUB7;Z=USR(G+P);GOSUB7;Z=USR(G+S);GOSUB7;Z=USR(A+P);GOSUB7
26030 Z=USR(N);GOSUB7;Z=USR(O+P);GOSUB7;Z=USR(N);GOSUB7;Z=USR(A+P);GOSUB7;Z=USR(G);GOSUB7;RETURN
27000 C$="JOHN HENRY";Y$=C$
27010 Z=USR(G+V);Y=Y+1;GOSUB7;Z=USR(A+V);GOSUB7;Z=USR(N+V);GOSUB7;Z=USR(N+Q)
:GOSUB7;Z=USR(N+T);GOSUB7;Z=USR(N+X);GOSUB7;Z=USR(A+V);GOSUB7;Z=USR(C+V);GOSUB7
:Z=USR(N+V);GOSUB7;Z=USR(N+P);GOSUB7;PORT1=170182;NEXT
27020 Z=USR(N+X);GOSUB7;Z=USR(N+X);GOSUB7;Z=USR(N+V);GOSUB7;Z=USR(G+V);GOSUB7
:Z=USR(M+S);GOSUB7;Z=USR(A+S);GOSUB7;Z=USR(G+P);GOSUB7;RETURN
28000 C$="MAD LAMB SYNE";Y$="LAMB S"
28010 Z=USR(D+S);Y=Y+1;GOSUB7;Z=USR(G+Q);GOSUB7;Z=USR(G+V);GOSUB7;Z=USR(G+S)
:GOSUB7;Z=USR(B+S);GOSUB7;Z=USR(A+Q);GOSUB7;Z=USR(G+V);GOSUB7;Z=USR(A+S);GOSUB7
:Z=USR(B+S);GOSUB7
28020 Z=USR(G+V);GOSUB7;Z=USR(G+Q);GOSUB7;Z=USR(B+S);GOSUB7;Z=USR(O+R);GOSUB7
:Z=USR(S);GOSUB7;RETURN
29000 C$="THE LONESOME ROAD";Y$="LONESOME ROAD"
29010 Z=USR(A+V);Y=Y+1;GOSUB7;Z=USR(N+P);GOSUB7;Z=USR(F+U);GOSUB7;Z=USR(A+P)
:GOSUB7;Z=USR(A+U);GOSUB7;Z=USR(M+P);GOSUB7;Z=USR(H+U);GOSUB7
:Z=USR(G+U);GOSUB7;Z=USR(G+V);GOSUB7;Z=USR(M+U);GOSUB7;Z=USR(N+P);GOSUB7;Z=USR(A+U);GOSUB7
:Z=USR(G+P);GOSUB7;Z=USR(A+V);GOSUB7;Z=USR(F);GOSUB7;RETURN
30000 C$="THE BEAR WENT OVER THE MOUNTAIN";Y$=C$
30010 Z=USR(D+U);Y=Y+1;GOSUB7;Z=USR(E+W);GOSUB7;Z=USR(K+U);GOSUB7;Z=USR(K+W)
:GOSUB7;Z=USR(K+W);GOSUB7;Z=USR(E+W);GOSUB7;Z=USR(K+W);GOSUB7;Z=USR(G+S);GOSUB7
:Z=USR(K+U);GOSUB7
30020 Z=USR(K+U);GOSUB7;Z=USR(E+U);GOSUB7;Z=USR(E+W);GOSUB7;Z=USR(E+W);GOSUB7
:Z=USR(D+W);GOSUB7;Z=USR(E+W);GOSUB7;Z=USR(K+S);GOSUB7;Z=USR(D+U);GOSUB7;RETURN
31000 C$="BUFFALO GALS";Y$="BUFFALO G"
31010 Z=USR(D+V);Y=Y+1;GOSUB7;Z=USR(D+V);GOSUB7;Z=USR(D+S);GOSUB7;Z=USR(K+S)
:GOSUB7;Z=USR(A+V);GOSUB7;Z=USR(A+V);GOSUB7;Z=USR(B+S);GOSUB7;Z=USR(A+V);GOSUB7
:Z=USR(A+V);GOSUB7;Z=USR(K+P);GOSUB7
31020 Z=USR(A+S);GOSUB7;Z=USR(G+V);GOSUB7;Z=USR(G+V);GOSUB7;Z=USR(E+P);GOSUB7
:Z=USR(B+S);GOSUB7;Z=USR(A+V);GOSUB7;Z=USR(A+V);GOSUB7;Z=USR(K+P);GOSUB7;RETURN
32000 C$="CLEMMENTINE";Y$=C$
32010 Z=USR(F+V);Y=Y+1;GOSUB7;Z=USR(F+2560);GOSUB7;Z=USR(F+U);GOSUB7;Z=USR(C+U)
:GOSUB7;Z=USR(A+V);GOSUB7;Z=USR(A+2566);GOSUB7;Z=USR(A+U);GOSUB7;Z=USR(B+U)
:GOSUB7;Z=USR(F+W);GOSUB7;Z=USR(F+W);GOSUB7;Z=USR(N+W);GOSUB7;Z=USR(N+W);GOSUB7
:Z=USR(A+W);GOSUB7;Z=USR(G+R);GOSUB7;Z=USR(C+V);GOSUB7;Z=USR(A+2566);GOSUB7

```

Program Listing 2 Continues

Program Listing 2 Continued

```

B7:Z=USR(M+U);GOSUB7;Z=USR(M+U);GOSUB7;Z=USR(A+V);GOSUB7
3283 Z=USR(C+2568);GOSUB7;Z=USR(A+U);GOSUB7;Z=USR(F+U);GOSUB7;Z=USR(F+V);G
OSUB7;Z=USR(A+2568);GOSUB7;Z=USR(G+U);GOSUB7;Z=USR(C+U);GOSUB7;Z=USR(E+V);G
OSUB7;Z=USR(G+2568);GOSUB7;Z=USR(F+R);GOSUB7;RETURN
33888 CS="DIXIE";YS=CS
33810 Z=USR(F+X);Y=Y+1;GOSUB7;Z=USR(D+X);GOSUB7;Z=USR(H+V);GOSUB7;Z=USR(H+V
);GOSUB7;Z=USR(M+X);GOSUB7;Z=USR(C+X);GOSUB7;Z=USR(D+X);GOSUB7;Z=USR(122+X)
;GOSUB7;Z=USR(F+V);GOSUB7
33828 Z=USR(F+V);GOSUB7;Z=USR(F+V);GOSUB7;Z=USR(D+V);GOSUB7;Z=USR(G+V);GOSU
B7;Z=USR(G+V);GOSUB7;Z=USR(G+T);GOSUB7;Z=USR(F+X);GOSUB7;Z=USR(G+T);GOSUB7;
Z=USR(F+X);GOSUB7;Z=USR(G+X);GOSUB7;Z=USR(A+X);GOSUB7;Z=USR(M+X);GOSUB7
3383 Z=USR(M+X);GOSUB7;Z=USR(O+Q);GOSUB7;Z=USR(M+X);GOSUB7;Z=USR(F+X);GOSU
B7;Z=USR(M+Q);GOSUB7;Z=USR(F+X);GOSUB7;Z=USR(D+X);GOSUB7;Z=USR(F+Q);GOSUB7
Z=USR(C+X);GOSUB7;Z=USR(D+X);GOSUB7;Z=USR(H+Q);GOSUB7;RETURN
34888 CS="OH! GUBANNA";YS=" SU"
34810 Z=USR(M+8);Y=Y+1;GOSUB7;Z=USR(M+8);GOSUB7;Z=USR(O+V);GOSUB7;Z=USR(O+8)
;GOSUB7;Z=USR(O+V);GOSUB7;Z=USR(M+V);GOSUB7;Z=USR(N+V);GOSUB7;Z=USR(A+V);G
OSUB7;Z=USR(P+V);GOSUB7
34828 Z=USR(G+Q);GOSUB7;Z=USR(F+X);GOSUB7;Z=USR(G+X);GOSUB7;Z=USR(A+V);GOSU
B7;Z=USR(N+V);GOSUB7;Z=USR(N+V);GOSUB7;Z=USR(O+V);GOSUB7;Z=USR(N+V);GOSUB7;
Z=USR(A+V);GOSUB7
34838 Z=USR(F+P);GOSUB7;Z=USR(G+X);GOSUB7;Z=USR(A+V);GOSUB7;Z=USR(A+V);GOSU
B7;Z=USR(G+V);GOSUB7;Z=USR(C+V);GOSUB7;Z=USR(F+P);GOSUB7;RETURN
35888 CS="PICK A BALE OF COTTON";YS="BALE OF COTTON"
35810 Z=USR(G+V);Y=Y+1;GOSUB7;Z=USR(G+V);GOSUB7;Z=USR(B+S);GOSUB7;Z=USR(G+S)
;GOSUB7;Z=USR(G+V);GOSUB7;Z=USR(G+V);GOSUB7;Z=USR(G+S);GOSUB7;Z=USR(G+V);G
OSUB7;Z=USR(C+V);GOSUB7
35828 Z=USR(G+V);GOSUB7;Z=USR(G+V);GOSUB7;Z=USR(E+V);GOSUB7;Z=USR(D+V);GOSU
B7;Z=USR(D+V);GOSUB7;Z=USR(E+V);GOSUB7;Z=USR(G+S);GOSUB7;Z=USR(G+S);GOSUB7;
Z=USR(G+V);GOSUB7
35838 Z=USR(G+V);GOSUB7;Z=USR(G+S);GOSUB7;Z=USR(D+V);GOSUB7;Z=USR(D+V);GOSU
B7;Z=USR(K+V);GOSUB7;Z=USR(F+V);GOSUB7;Z=USR(G+P);GOSUB7;RETURN
36888 CS="SHE'LL BE COMING ROUND THE MOUNTAIN";YS="ROUND THE MOUNTAIN"
36810 Z=USR(D+V);Y=Y+1;GOSUB7;Z=USR(E+V);GOSUB7;Z=USR(G+V);GOSUB7;Z=USR(G+V)
;GOSUB7;Z=USR(G+V);GOSUB7;Z=USR(G+V);GOSUB7;Z=USR(E+V);GOSUB7;Z=USR(D+V);G
OSUB7;Z=USR(I+V);GOSUB7
36828 Z=USR(D+V);GOSUB7;Z=USR(G+P);GOSUB7;PORT1=10364;NEXT;Z=USR(G+V);GOSU
B7;Z=USR(A+V);GOSUB7;Z=USR(B+V);GOSUB7;Z=USR(B+V);GOSUB7;Z=USR(B+V);GOSUB7;
Z=USR(B+V);GOSUB7
36838 Z=USR(O+V);GOSUB7;Z=USR(B+V);GOSUB7;Z=USR(A+V);GOSUB7;Z=USR(G+V);GOSU
B7;Z=USR(A+P);GOSUB7;RETURN
37888 CS="GO TELL AUNT RHODY";YS="GO TELL AUNT R"
37810 Z=USR(B+P);Y=Y+1;GOSUB7;Z=USR(B+S);GOSUB7;Z=USR(A+S);GOSUB7;Z=USR(G+P)
;GOSUB7;Z=USR(G+P);GOSUB7;Z=USR(A+P);GOSUB7;Z=USR(A+S);GOSUB7;Z=USR(N+S);G
OSUB7;Z=USR(B+S);GOSUB7;Z=USR(A+S);GOSUB7;Z=USR(G+P);GOSUB7;Z=USR(O+P);GOSU
B7
37828 Z=USR(O+S);GOSUB7;Z=USR(N+S);GOSUB7;Z=USR(B+P);GOSUB7;Z=USR(G+Q);GOSU
B7;Z=USR(G+V);GOSUB7;Z=USR(A+S);GOSUB7;Z=USR(G+S);GOSUB7;Z=USR(A+S);GOSUB7;
Z=USR(B+S);GOSUB7;Z=USR(G);GOSUB7;RETURN
38888 CS="MINN JOHNNY COMES MARCHING HOME";YS=CS
38810 Z=USR(D+V);Y=Y+1;GOSUB7;Z=USR(D+V);GOSUB7;Z=USR(G+V);GOSUB7;Z=USR(G+V)
;GOSUB7;Z=USR(G+V);GOSUB7;Z=USR(A+V);GOSUB7;Z=USR(N+U);GOSUB7;Z=USR(A+W);G
OSUB7;Z=USR(M+U);GOSUB7
38828 Z=USR(G+V);GOSUB7;Z=USR(F+R);GOSUB7;Z=USR(D+W);GOSUB7;Z=USR(P+R);GOSU
B7;Z=USR(D+W);GOSUB7;Z=USR(D+W);GOSUB7;Z=USR(G+W);GOSUB7;Z=USR(G+W);GOSUB7;
Z=USR(O+U);GOSUB7
38838 Z=USR(A+W);GOSUB7;Z=USR(M+U);GOSUB7;Z=USR(A+W);GOSUB7;Z=USR(M+U);GOSU
B7;Z=USR(N+W);GOSUB7;Z=USR(O+R);GOSUB7;Z=USR(M+W);GOSUB7;Z=USR(O+R);GOSUB7;
RETURN
39888 CS="YANKEE DOODLE";YS=CS
39810 Z=USR(K+T);Y=Y+1;GOSUB7;Z=USR(L+X);GOSUB7;Z=USR(K+V);GOSUB7;Z=USR(E+V)
;GOSUB7;Z=USR(K+V);GOSUB7;Z=USR(L+V);GOSUB7;Z=USR(A+S);GOSUB7;Z=USR(E+T);G
OSUB7;Z=USR(K+X);GOSUB7
39828 Z=USR(E+V);GOSUB7;Z=USR(D+V);GOSUB7;Z=USR(J+S);GOSUB7;Z=USR(B+S);GOSU
B7;Z=USR(K+T);GOSUB7;Z=USR(L+X);GOSUB7;Z=USR(K+V);GOSUB7;Z=USR(E+V);GOSUB7;
Z=USR(K+V);GOSUB7
39838 Z=USR(L+V);GOSUB7;Z=USR(A+V);GOSUB7;Z=USR(K+V);GOSUB7;Z=USR(B+V);GOSU
B7;Z=USR(A+V);GOSUB7;Z=USR(L+V);GOSUB7;Z=USR(K+V);GOSUB7;Z=USR(B+V);GOSUB7;
Z=USR(A+V);GOSUB7;RETURN
40888 CS="AMERICA THE BEAUTIFUL";YS="AMERICA"
40810 Z=USR(E+S);Y=Y+1;GOSUB7;Z=USR(E+Q);GOSUB7;Z=USR(J+V);GOSUB7;Z=USR(J+S)
;GOSUB7;Z=USR(E+S);GOSUB7;Z=USR(E+Q);GOSUB7;Z=USR(I+V);GOSUB7;Z=USR(I+S);G
OSUB7;Z=USR(J+S);GOSUB7
40828 Z=USR(D+S);GOSUB7;Z=USR(E+S);GOSUB7;Z=USR(K+S);GOSUB7;Z=USR(L+S);GOSU
B7;Z=USR(E);GOSUB7;RETURN
41888 CS="BATTLE HYMN OF THE REPUBLIC";YS=CS
41810 Z=USR(F+V);Y=Y+1;GOSUB7;Z=USR(F+T);GOSUB7;Z=USR(F+X);GOSUB7;Z=USR(F+T)
;GOSUB7;Z=USR(122+X);GOSUB7;Z=USR(D+T);GOSUB7;Z=USR(F+X);GOSUB7;Z=USR(M+T)
;GOSUB7;Z=USR(M+X);GOSUB7
41828 Z=USR(O+T);GOSUB7;Z=USR(O+X);GOSUB7;Z=USR(O+T);GOSUB7;Z=USR(N+X);GOSU
B7;Z=USR(M+S);GOSUB7;Z=USR(M+T);GOSUB7;Z=USR(A+X);GOSUB7;Z=USR(G+T);GOSUB7;
Z=USR(G+X);GOSUB7;Z=USR(G+T);GOSUB7;Z=USR(A+X);GOSUB7
41838 Z=USR(M+T);GOSUB7;Z=USR(A+X);GOSUB7;Z=USR(M+T);GOSUB7;Z=USR(G+X);GOSU
B7;Z=USR(F+T);GOSUB7;Z=USR(G+X);GOSUB7;Z=USR(F+T);GOSUB7;Z=USR(D+X);GOSUB7;
Z=USR(P+S);GOSUB7;RETURN
42888 CS="THE CAISSONS";YS="CAISSONS"
42810 Z=USR(G+V);Y=Y+1;GOSUB7;Z=USR(E+V);GOSUB7;Z=USR(G+S);GOSUB7;Z=USR(G+V)
;GOSUB7;Z=USR(E+V);GOSUB7;Z=USR(G+S);GOSUB7;Z=USR(G+V);GOSUB7;Z=USR(E+V);G
OSUB7;Z=USR(G+T);GOSUB7
42828 Z=USR(A+V);GOSUB7;Z=USR(G+V);GOSUB7;Z=USR(E+V);GOSUB7;Z=USR(G+S);GOSU
B7;Z=USR(E+V);GOSUB7;Z=USR(F+V);GOSUB7;Z=USR(G+V);GOSUB7;Z=USR(P+S);GOSUB7
42838 Z=USR(D+V);GOSUB7;Z=USR(G+V);GOSUB7;Z=USR(P+S);GOSUB7;Z=USR(D+V);GOSU
B7;Z=USR(C+P);GOSUB7;RETURN
43888 CS="SHENANDOAH";YS=CS
43810 Z=USR(H+U);Y=Y+1;GOSUB7;Z=USR(122+V);GOSUB7;Z=USR(122+V);GOSUB7;Z=USR
(122+P);PORT1=10182;NEXT;GOSUB7;Z=USR(F+T);GOSUB7;Z=USR(G+T);GOSUB7;Z=USR(M+T)
;GOSUB7;Z=USR(N+Q);GOSUB7;Z=USR(M+Q);GOSUB7;PORT1=10121;NEXT;Z=USR(61+
U);GOSUB7
43828 Z=USR(O+U);GOSUB7;Z=USR(N+P);GOSUB7;Z=USR(M+U);GOSUB7;Z=USR(N+U);GOSU
B7;Z=USR(M+U);GOSUB7;Z=USR(C+U);GOSUB7;Z=USR(M+P);GOSUB7;RETURN
44888 CS="THE SLOOP JOHN B.";YS="SLOOP JOHN B"
44810 FORL=102;Z=USR(D+S);Y=Y+1;GOSUB7;Z=USR(B+V);GOSUB7;Z=USR(B+S);GOSU
B7;Z=USR(M+V);GOSUB7;Z=USR(B+S);GOSUB7;Z=USR(N+S);GOSUB7;Z=USR(B+P);GOSUB7;P
ORT1=10364;NEXT;NEXT;Z=USR(D+S);GOSUB7;Z=USR(B+V);GOSUB7
44828 Z=USR(B+S);GOSUB7;Z=USR(M+V);GOSUB7;Z=USR(B+S);GOSUB7;Z=USR(N+S);GOSU
B7;Z=USR(O+Q);GOSUB7;Z=USR(O+V);Z=USR(O+V);GOSUB7;Z=USR(N+V);GOSUB7;Z=USR(B+S)
;GOSUB7;Z=USR(A);GOSUB7;RETURN
45888 CS="SHOD FLY";YS=CS
45810 Z=USR(B+V);Y=Y+1;GOSUB7;Z=USR(D+S);GOSUB7;Z=USR(G+V);GOSUB7;Z=USR(B+T)
;GOSUB7;Z=USR(N+X);GOSUB7;Z=USR(A+S);GOSUB7;Z=USR(A+V);GOSUB7;Z=USR(D+S);G
OSUB7;Z=USR(K+V);GOSUB7;Z=USR(A+T);GOSUB7;Z=USR(B+X);GOSUB7;Z=USR(G+S);GOSU
B7
45828 Z=USR(B+V);GOSUB7;Z=USR(D+S);GOSUB7;Z=USR(G+V);GOSUB7;Z=USR(B+T);GOSU
B7;Z=USR(M+X);GOSUB7;Z=USR(A+V);GOSUB7;Z=USR(A+V);GOSUB7;Z=USR(O+T);GOSUB7;
Z=USR(O+X);GOSUB7;Z=USR(O+T);GOSUB7;Z=USR(N+X);GOSUB7
45838 Z=USR(B+V);GOSUB7;Z=USR(A+V);GOSUB7;Z=USR(G+S);GOSUB7;RETURN
46888 Z=USR(C+T);Z=USR(C+X);Z=USR(F);Z=USR(C+T);Z=USR(A);Z=USR(C)
+T);Z=USR(F+X);Z=USR(A+S);Z=USR(C+T);Z=USR(F+X);Z=USR(A+S);Z=USR(C+T);Z=USR
(F+X);Z=USR(A)
49810 Z=USR(F+T);Z=USR(A+X);Z=USR(N);Z=USR(A+S);Z=USR(F+S);Z=USR(C);Z=USR(C
+T);Z=USR(C+X);Z=USR(F);RETURN
50888 PORT1=10108;LEN(XS)+1;IFY$=MID$(XS,11,LEN(YS))RETURN
50838 NEXT;11=8;RETURN
51888 FORN1=104;FORN1=135T018STEP=5;Z=USR(Y1+512);NEXT;FORN2=10108STEP5;
Z=USR(Y2+512);NEXT;NEXT;RETURN
52888 Z=USR(32664);Z=USR(255);RETURN
60888 PRINT;PRINT;PRINT;PRINT;PRINT;PRINT;PRINT;PRINT;PRINT;PRINT;PRINT;PRINT
AGAIN;CENTER;(Y/M) *DU$;IFLEFT$(DU$,1) *M"THE61888ELSERUN
61888 PORT1=255T018STEP=1;Z=USR(Y1+256);NEXT;CLS;END

```

PREMIUM CASSETTES

COMPUTER GRADE
100% ERROR-FREE
FULLY GUARANTEED

MANUFACTURER PRICES



The Micro-Trac™ Generation

- High Frequency Response • Wide Dynamic Range •
- Used by Software Firms & Computer Hobbyists •
- Choice of School Districts Nationwide •

LENGTH	12-PAK	24-PAK
C-05	\$.69	\$.59
C-10	\$.79	\$.69
C-20	\$.99	\$.89
C-30	\$1.19	\$1.09
C-60	\$1.49	\$1.39
C-90	\$1.79	\$1.69
*CASES	\$.21	\$.20

*Cases are highly recommended to protect sensitive cassettes.

—UPS SHIPPING—
(No P.O. Boxes please)

\$2.00 (12-pak) \$3.00 (24-pak)
—Canadian shipping multiply by 2—

#1 COMPUTER TAPE IN THE USA!

—write for volume prices—

TOLL-FREE
(orders only)

1-800-426-4747
ext. 480

In Washington State
1-800-562-4555
ext. 480



MICRO-80™ INC.

E. 2665 Busby Road
Oak Harbor, WA 98277
—Distributors Wanted—



An updated version of one of 80 Micro's first.

Home Budgeteer—Reprise

*Manuel R. Pablo
8739 Cuttermill Place
Springfield, VA 22153*

When I saw David Andresen's "Household Accountant" program in the February 1980 issue of *80 Microcomputing*, I rejoiced! Here was just the program I was looking for!

I already know how to balance my checkbook. I can tell which checks are missing. I know which ones have been returned. I do not need to know how many checks lie in the range between \$32.57 and \$68.12. What I do need to know is, how much am I spending on the phone bill? Which month was my high electricity month? How high was it? Did I pay my quarterly water bill twice, by mistake?

Andresen's program made these questions easy to answer.

I did not need to load several different modules in succession. His program was just what I was looking for. Except . . .

Andresen wrote his program for a minimal 16K tape-based system. That imposed constraints which I readily accepted until I finally moved up to a disk system. Equipped with added memory and rapid loading, I added some bells and whistles Andresen had to leave off. But

my enhancements soon made the program cumbersome. I did a logical rewrite, incorporating each nicety in an orderly manner. I also made provision for future revisions.

My Additions

The new version is shown in the Program Listing. Relieved of memory restrictions, I incorporated a number of new features.

Expense categories are listed in a menu, and are named in the printouts. You do not need to use code numbers or a code card. Previous to this, I had a recurring nightmare. In my dream, I would load ten years of data, then search in vain for my decoder list. All those checks, and I could not remember the secret code! Now, the program includes everything.

You can opt for simultaneous printout along with the video display. The program even checks to see if your printer is on.

An all-encompassing total analysis option will print the results for every category auto-

matically. Have a cup of coffee while the printer chugs away. While sipping your coffee, chuckle at how disappointed the IRS agent will be when he sees your detailed records.

Subroutines do all the work. This makes program flow easier to follow. It also means you can add your own customizations with ease—just tack on more subroutines.

The program includes a quick plot subroutine. This autoscaling plot provides a graphic overall look at your data. It automatically selects the maximum cost month and prints the maximum cost month total.

I have added extended error-trapping and more detailed REMarks.

This program should run as

A	Amount of check
CN	Check number
CT	Check category
G	PRINT USING string variables
I	Index counter
IM	Month with maximum expenses
J	Index counter
M	Month number
N	Index counter
Q	Complete printout query flag
Q1	Query flag
S	Query flag
S1	Query flag
S2	Query flag
T	Monthly total of expenses
TM	Maximum expense month number
ZM	Graphic scaling factor

Table 1. Variable List

The Key Box

Basic Level II
Models I or III
16K RAM

TURN YOUR COMPUTER INTO A GRAPHICS MACHINE

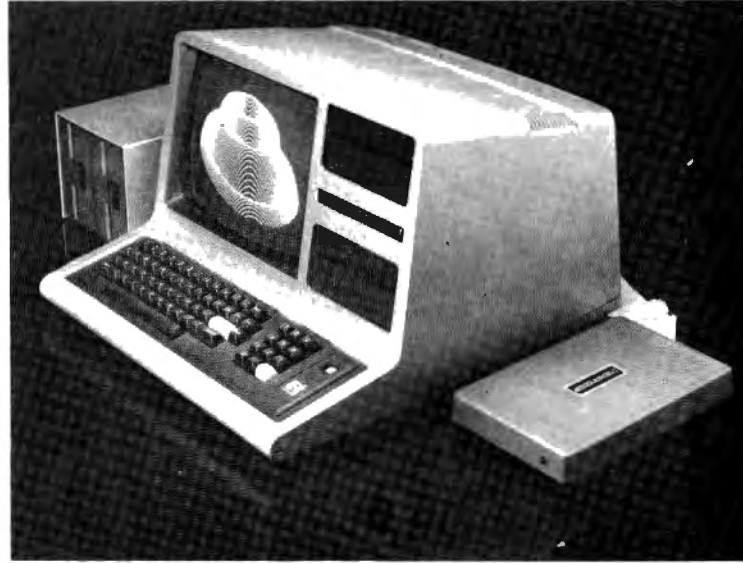
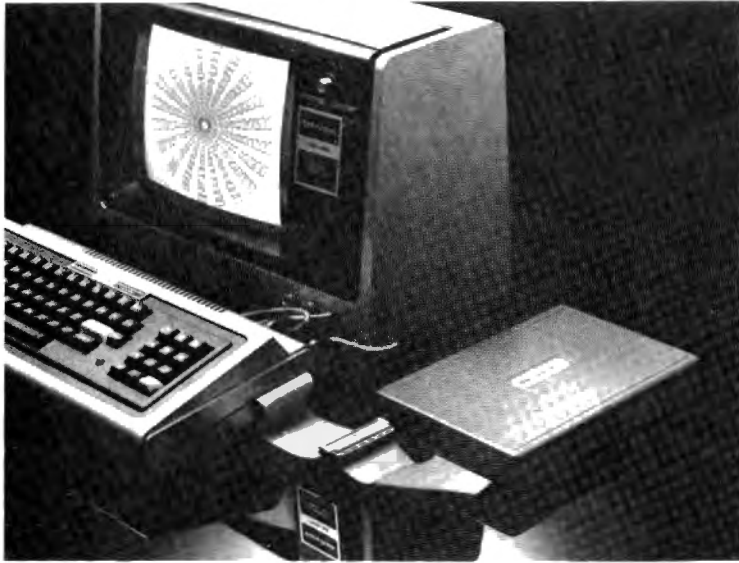

WITH THE MIKEEANGELO GRAPHIC SYSTEM!!

MIKEEANGELO is a hardware/software system designed for the TRS-80 model I & III computers. When installed, your 80 will come alive with graphic ability!!

If you've been waiting for a graphic system with the best dots/dollars ratio, take a look at our MIKEEANGELO.

HARDWARE

- TOTAL SCREEN INVERSE VIDEO
- TWO MODES OF DENSITY:
 - 384 x 192 or 191 x 192 for Model I
 - 512 x 192 or 256 x 192 for Model III
- EVERY DOT CAN BE SET, RESET or TESTED
- 12288 BYTES OF FAST 200 ns MEMORY
- FUNCTIONS SELECTED BY OUTPUT PORT #254.
- MEMORY MAPPED FOR SPEED
- OCCUPIES LAST 16K BLOCK OF MEMORY
- CAN BE USED AS NORMAL MEMORY (if you have 32K or more of memory)
- COLOR COORDINATED ENCLOSURE
- DOES NOT CONFLICT WITH DISK OR CASSETTE I/O
- SELF SWITCHING POWER SUPPLY (Powers up with Computer)
- COMES WITH IT'S OWN WALL TRANSFORMER
- NOT A CHARACTER GENERATOR!!
- EASY INSTALLATION (Requires only 18 solder connections and one trace/pin cut)

*1 MIKEEANGELO is a trademark for Mikee Electronics Corp

*2 TRS-80 is a trademark for the Tandy Corp

*3 Opening your TRS 80 will void the limited warranty

*4 90 day warranty, full refund or replacement

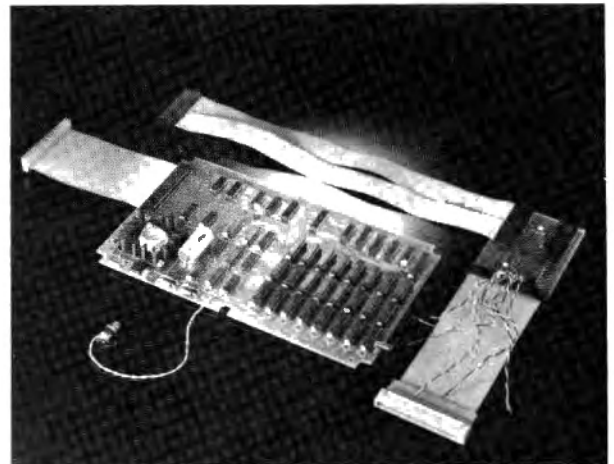

SOFTWARE

- COMES WITH SAMPLE AND DRIVER SOFTWARE
- USABLE THROUGH BASIC OR MACHINE LANGUAGE
- EXCELLENT INSTALLATION/ OPERATION MANUAL

TOOL KITS AVAILABLE FOR JUST \$15.00

MANUAL AVAILABLE SEPARATELY FOR \$15.00

Full price of manual will be deducted from the Purchase Price of MIKEEANGELO when ordered.

PREPAID, COD, MASTERCARD, VISA, or MASTERCARD ORDERS ACCEPTED. FOB: Bellevue, Wa.

U.S. Currency ONLY. Stock to 30 days delivery.

DEALERS INQUIRIES INVITED.

ORDER NOW FOR ONLY \$369.

Complete with power supply, case software and manual.

WRITE for FREE BROCHURE or call for more information.

MIKEE ELECTRONICS CORPORATION

P.O. Box 3813 Bellevue, Washington 98009
Telephone 206/451-0574

easily on a Model III as on my Model I, except for the PEEK to see if the printer is on. If you own a Model III you will have to make the change yourself.

Check information is included within the program as Data statements. This means you will have a longer program to save each month. In exchange, you get much simpler editing, and a

Without a DOS, you can still use CLOAD and CSAVE until you graduate to the convenience of disk.

With the check Data statements at the end of the program, simply delete lines 10010-19999 to clear the decks for next year's checks. If you significantly revise the program, you can instead delete the program (lines

values? Next you can customize a routine for your particular printer to produce the plot. Tinker a little, and you can make it just the program for you. I did. ■

Manuel Pablo is employed by Night Vision and Electric Optics Laboratory in Ford Belvoir, VA. His hobbies are photography and backpacking.

"I do not need to know how many checks lie in the range between \$32.57 and \$68.12."

stand-alone program. If this is not to your liking, just add a disk Read routine. To avoid multiple disk accesses, you will probably want to read your data into an array. Do not forget a Save routine.

As the program stands, you do not need a DOS, but more than 16K of memory would help.

10-10000), and save the check data. Then merge your old data to your new program.

If you have disk and want an expense program that you can customize with ease, then this program may be just the one for you. How about altering the plot routine to display the y-axis

GOLDLABEL™ BLANK CASSETTES

*PREMIUM 5 SCREW SHELL *DIGITAL DATA QUALITY *LOW NOISE *MADE IN USA

1 DOZEN C-10 LENGTH \$8 00 + \$2 00 shpg 1 DOZEN C-30 LENGTH \$11 00 + \$2 00 shpg
2 DOZEN C-10 LENGTH \$15 00 + \$3 50 shpg 2 DOZEN C-30 LENGTH \$20 00 + \$3 50 shpg
Individual storage boxes (sold only with cassettes) \$2 40 per dozen
CASSETTE CADDY \$5 49 + \$1 50 shpg /\$3 95 with cassette purchase (no shpg chg on caddy)

Foreign orders include shipping at 16 oz per doz tapes/9 oz per caddy/13 oz per doz boxes
Shipments in U.S. are by UPS (no delivery to P.O. Boxes) Add \$1 50 per doz tapes for First Class Mail

!!! NEW !!! CASSETTE CADDY !!! NEW !!!
TIRED OF MISPLACED TAPES AND A CLUTTERED WORK AREA? TRY OUR HINGED TOP SMOKED-PLASTIC CADDY THAT HOLDS 12 TAPES IN ONE HANDY LOCATION



Visa and Mastercard accepted (include expiration date) Orders paid by cashier's check money order or bankcard are shipped within 48 hours Personal checks take 1-2 wks No COD Some foreign sales are restricted Texas residents add 5% tax

SEND ORDERS TO: COLOR SOFTWARE SERVICES

P. O. BOX 1723

GREENVILLE, TEXAS 75401

* DEALER INQUIRIES INVITED * QUANTITY DISCOUNTS AVAILABLE

ALSO AVAILABLE COLORSOFT™ software for the TRS-80™ color computer * Games * Educational * Financial * Home-Personal Over 50 software items available Send \$1 for catalog and \$2 00 discount coupon

Program Listing

```

10 REM *A Simpleminded Expense Analyzer*
20 REM *by Manuel R. Pablo *
30 REM *Inspired by an article by David Andresen, 88 Microcomputing, Feb 1988*
40 REM *Latest revision 29 November 1981*
50 CLS
60 PRINT@15,"Check Analyzer Program"
70 PRINT:PRINT"Enter all checks written in >>1981<<."
80 PRINT"you can obtain an analysis by month or by category."
90 PRINT"Add or change checks with DATA statements."
100 REM *Choose Analysis or Add-Checks-to-File mode*
110 PRINT:PRINT"Do you wish to (1) analyze checks,"
120 INPUT"or (2) add checks via DATA statements";S
130 IF S<1 OR S>2 THEN PRINT"Try again..":GOTO 110
140 IF S=2 THEN GOTO 9000
150 CLEAR 63:DEFINT C,I-M,S
160 G$="$$00,000.00"
170 REM *Initialize Housekeeping*
180 REM *Array values are not read via DATA statements so that*
190 REM *the RESTORE command will affect check data only*
200 DIM M$(2),NS(24),T(12)
210 M$(1)="Jan":M$(2)="Feb":M$(3)="Mar":M$(4)="Apr":M$(5)="May"
220 M$(6)="Jun":M$(7)="Jul":M$(8)="Aug":M$(9)="Sep"
230 M$(10)="Oct":M$(11)="Nov":M$(12)="Dec"
240 REM *Expense Categories*
250 REM *Not elegant, but easy to change*
260 NS(1)="House Payments"
270 NS(2)="VEPCO"
280 NS(3)="CaP"
290 NS(4)="WGL"
300 NS(5)="FCWA"
310 NS(6)="Trash Service"
320 NS(7)="Taxes"
330 NS(8)="Clothes"
340 NS(9)="House Maintenance"
350 NS(10)="Car Maintenance"
360 NS(11)="Subscriptions"
370 NS(12)="Electronics"
380 NS(13)="Profess. Dues"
390 NS(14)="Medical"
400 NS(15)="Insurance"
410 NS(16)="Tax Deductible"
420 NS(17)="Entertainment"
430 NS(18)="Karate"
440 NS(19)="Charge Accounts"
450 NS(20)="Savings"
460 NS(21)="Li'l Spring Farm"
470 NS(22)="Household"
480 NS(23)="Miscellaneous"
490 NS(24)="ALL CATEGORIES"
500 REM *Select Complete Printout Option*
510 S=0:FOR I=1 TO 12:T(I)=0:NEXT I:T#=0:ZM=1
520 INPUT"Want COMPLETE printed record (yes=1) for all 24 categories";Q
530 IF Q<1 THEN GOTO 560
540 IF PEEK(14312)<>63 THEN PRINT"Printer NOT READY. Try again."
550 GOTO 520 ELSE Q1=0
560 RESTORE:SI=Q1:GOSUB2000:GOSUB3000
570 CLS:ZM=1:T#=0:FOR J=1 TO 12:T(J)=0:NEXT J:GOSUB 1000
580 PRINT:INPUT"which category number";S1
590 IF S1<1 OR S1>24 THEN PRINT"Choose again..":GOTO 570
590 GOSUB 2000
600 GOSUB 3000
610 REM *Select from Menu*
620 GOSUB 4000
630 IF S2<1 OR S2>5 THEN PRINT "Try again..":GOTO 630
640 RESTORE
650 ON S2 GOTO 560,600,660,670,7000
660 GOSUB 5000:GOTO 620
670 GOSUB 6000:GOTO 620
990 REM *Subroutine to print Category Selection List*
1000 FOR J=1 TO 12
1010 PRINT USING"##. ";J;:PRINT " ";NS(J):TAB(32);:PRINT USING "##. ";J+12;:PRINT " ";NS(J+12)
1020 NEXT J
1030 RETURN
1990 REM *This <Subroutine 2000> is the Heart of the Program*
2000 READ CN:PRINT@55,CN;
2010 IF CN=-1 THEN 2000
2020 READ M,A,CT
2030 IF S1=24 THEN 2050
2040 IF CT<>S1 THEN 2070
2050 T#=#+A
2060 T(M)=T(M)+A
2070 GOTO 2000
2080 RETURN
2990 REM *Display and/or Print Monthly Expenses*
3000 CLS
3010 PRINT"Category";S1,NS(S1)
3020 IF Q=1 THEN LPRINT"Category";S1,NS(S1)
3030 PRINT"Month", " Subtotal", "Month", " Subtotal"
3040 IF Q=1 THEN LPRINT"Month", " Subtotal", "Month", " Subtotal"
3050 PRINT STRING$(63,"-")
3060 IF Q=1 THEN LPRINT$PRINT$(63,"-")
3070 FOR J=1 TO 6
3080 REM *Rescale values if array has been scaled by screen plot factor ZM*
3090 PRINT M$(J);:PRINT USING G$(T(J)/ZM);:PRINT:PRINT M$(J+6);:

```

Program continues

Program continued

```

PRINT USING G$;T(J+6)/M
3100 IF Q=1 THEN LPRINT M$(J);LPRINT USING G$;T(J)/M;LPRINT:
LPRINT M$(J+6);LPRINT USING G$;T(J+6)/M
3110 NEXT
3120 PRINT "Grand Total";PRINT USING G$;T$
3130 IF Q=1 THEN LPRINT "Grand Total";LPRINT USING G$;T$:LPRINT
CHR$(13)
3140 IF Q<>1 THEN GOTO 3180
3150 REM *Reset all variables*
3160 Q1=Q1+1:T$=0;FOR J=1 TO 12:T(J)=0:NEXT J
3170 IF Q1=25 THEN GOTO 3180 ELSE GOTO 550
3180 RETURN
3390 REM *Menu Display Subroutine*
4000 PRINT:PRINT "What next? ";
4010 PRINT "1. Select new category"
4020 PRINT "2. Review monthly expenses"
4030 PRINT "3. List check numbers"
4040 PRINT "4. Plot data on screen"
4050 PRINT "5. Quit ";INPUT S2
4060 RETURN
4990 REM *Show Data for Each Selected Check on Screen*
5000 CLS:I=1
5010 PRINT "Checks for Category ";S1;" :";M$(S1)
5020 PRINT "Check no. ", "Month", " Amount", "Category"
5030 PRINT STRING$(63,"-")
5040 READ CM
5050 IF CM=-1 THEN 5130
5060 READ N,A,CT
5070 IF S1=24 THEN GOTO 5090
5080 IF CT<>81 THEN 5120
5090 PRINT CM,M$(M),PRINT USING G$;A;PRINT:PRINT M$(S1)
5100 I=I+1
5110 IF I<13 THEN 5120 ELSE INPUT "Press ENTER to continue ";A$:I
=-1:CLS:GOTO 5010
5120 GOTO 5040
5130 INPUT "Press ENTER to continue..";A$
5140 RETURN
5390 REM *Screen Plot Subroutine. First find Max T(I)*
6000 CLS:TM=T(1):IM=1
6010 FOR I=2 TO 12
6020 IF T(I)>TM THEN TM=T(I):IM=I
6030 NEXT I
6040 REM *IM= month of max value, used in plot subroutine*
6050 GOSUB 6320
6060 REM *Multiply array by scale factor ZM*
6070 FOR I=1 TO 12:T(I)=T(I)*ZM:NEXT I
6080 REM *Draw horizontal lines*
6090 FOR I=1 TO 95
6100 SET(19+I,35):SET(19+I,5)
6110 NEXT I
6120 REM *Close box*
6130 FOR I=35 TO 6 STEP -1
6140 SET(20,I):SET(114,I)
6150 NEXT I
6160 REM *Set Horizontal tic marks*
6170 FOR I=3 TO 95 STEP 5:RESET(20+I,35):NEXT I
6180 REM *Print months*
6190 PRINT@770,"Jan Feb Mar Apr May Jun Jul Aug Sep Oct Nov Dec"
6200 REM *Print value for each month*
6210 FOR I=1 TO 12
6220 IF T(I)=0 THEN GOTO 6260
6230 FOR J=T(I) TO 0 STEP -1
6240 SET(15+8*I,35-T(I)+J)
6250 NEXT J
6260 NEXT I
6270 PRINT@142,"Max value occurred in ";M$(IM);": ";PRINT USING
G$;TM;
6280 PRINT@842,"Plot for: ";M$(S1);:PRINT@970,"Press ENTER to co
ntinue..";
6290 INPUT A$;
6300 RETURN
6310 REM *Scale factor determined*
6320 ZM=1
6330 IF TM>25 GOTO 6410
6340 REM *Routine for TM less than 25*
6350 IF TM*ZM<25 THEN GOTO 6460
6360 IF TM*ZM*5>25 THEN ZM=ZM*2:GOTO 6460
6370 IF TM*ZM*10>25 THEN ZM=ZM*5:GOTO 6460
6380 ZM=ZM*10
6390 GOTO 6350
6400 REM *Routine for TM greater than 25*
6410 IF TM*ZM/2<25 THEN ZM=ZM/2:GOTO 6460
6420 IF TM*ZM/5<25 THEN ZM=ZM/5:GOTO 6460
6430 IF TM*ZM/10<25 THEN ZM=ZM/10:GOTO 6460
6440 ZM=ZM/10
6450 GOTO 6410
6460 RETURN
7000 PRINT:PRINT "Hope I was of service...":END
8990 REM *Instructions for adding checks*
9000 CLS
9010 PRINT "Add checks via DATA statements"
9020 PRINT:PRINT "Use one DATA statement per check (easier to edi
t)"
9030 PRINT "The program will list some DATA statements for you."
9040 PRINT "Format- LineNum DATA L3300,1,9.95,10"
9050 PRINT:PRINT "Program reads CheckNum <CN> ;"
9060 PRINT "then, Month <M>, Amount <A>, Category <CT>"
9070 PRINT:PRINT "A CheckNum of -1 is End-of-File"
9080 PRINT:INPUT "Press ENTER when ready";A$
9090 CLS:LIST 10000-19999
10000 REM *Data Section*
13342 DATA 3342,1,10.00,16
13343 DATA 3343,1,16.56,19
13344 DATA 3344,1,30.00,12
13345 DATA 3345,1,17.33,10
13346 DATA 3346,1,13.73,23
13347 DATA 3347,1,10.00,23
13348 DATA 3348,1,5.00,16
13349 DATA 3349,1,53.89,5
13350 DATA 3350,1,20.26,19
19999 REM *Dummy line for update list*
55555 DATA -1

```

INNOVATION / QUALITY / SUPPORT
AT A REASONABLE PRICE

PIONEER SOFTWARE
1746 NORTH WEST 55TH. AVE. #204
LAUDERHILL, FLORIDA 33313
PHONE 1-(305)-739-2071



180

AT LAST... PRINTER HELP FOR SCRIPTIT USERS

SCRIPTIT IS A DISK OR CASSETTE BASED UNIVERSAL PARALLEL
PRINTER DRIVER MODIFICATION FOR DISK/CASSETTE SCRIPTIT.
COMPARE FEATURES AND YOU'LL BUY SCRIPTIT!

- 1.) ENTER/EXIT SCRIPTIT AT WILL WITHOUT LOSING TEXT BUF.
- 2.) OUTPUT ANY CODE(S) (M-255), DIRECT FROM THE TEXT.
- 3.) LETTER COMMANDS CONTROL <ALL> MX-80 TYPE FONTS FROM
THE TEXT PLUS VAR-LINESPACING, FORMS, TABBING + MORE
- 4.) WRITE FORM LETTERS AND INPUT DATA INTO REPORT FORMS
BY SPECIFYING AREAS TO INSERT TO DURING PRINTOUT.
- 5.) DISPLAY ONLY MODE,HELPS SHOW WHERE PAGES START/END.
- 6.) EDIT MODE FOR ERRORS,CHANGES,GRAPHICS OR PAUSING.
- 7.) INCORPORATE FULL GRAPHICS PICTURES INTO A PRINTOUT.
- NEW! DAISY WHEEL 2 VER. ALLOWS SUB/SUPER SCRIPTING (1/2
+ PROPORTIONAL UNDERLINING, 1/2 LINE SPACING, SLASH
NEW! ZERO'S,EMPHASIZED PRINTING,AB, ECHO,OVERSTRICING.
- 9.) PRINT OUT ANY PAGE OR PAGES IN THE TEXT BUFFER WITH
HEADERS, FOOTERS AND PAGE NUMBERS IN PLACE.
- 10.) UNDERLINE WITH <ANY> CHARACTER EVEN GRAPHICS. MX-80
- 11.) 6 SAMPLE PROGRAMS / DESIGNED FOR NON-PROGRAMMERS.
- 12.) 65 PAGE MANUAL, BOUND, INDEXED, PHOTO OFFSET PRINTED.
- 13.) RETURN PROG-DOC FOR REFUND-\$5.00 IF NOT SATISFIED.
- 14.) 2 VERSIONS INCLUDED WORK WITH ANY PARALLEL PRINTER

FAITH -- CONVERTI SCRIPTIT/IC FOR MODEL 3 TRSDOS 1.3 \$1.00
DISK SCRIPTIT MOD 1/1 = \$40.00 MOD 111,VERSION WORKS WITH
MODEL 1. SCRIPTIT/LC - NO USER PATCHING REQ. FOR MOD 1/3
CASSETTE SCRIPTIT MOD 1/3 = \$40.00 WORKS WITH SCRIPTS VER.
1.00 MOD 1/3 (REQ.32K+ LOWER CASE) SCRIPTIT IS A 4.5K PROG.
INSTANT SOFTWARE MAKES USE OF SCRIPTIT IN TYPESETTING IT'S
DOCUMENTATION. SCRIPTIT IS FULLY DOCUMENTED AND BIG FREE,
CHECK READER SERVICE FOR \$5.00 COUPON. FREE BROCHURE!!

<<<< PLEASE INCLUDE THIS INFORMATION WHEN ORDERING >>>>
NAME ----- MODEL 1 OR 3 CASSETTE/DISK
ADDRESS ----- TYPE PRINTER ----- SCRIPTIT VER #
CITY/STATE/ZIP/PHONE ----- MEMORY CONFIG ----- PAYMENT METHOD
CHECKS - MONEY ORDERS / PREFERRED --- COD'S ALSO ACCEPTED

PIONEER SOFTWARE ANNOUNCES CRAYON

BUY CRAYON AND SAVE BIG ON PRINTING COSTS !!!

JUST ENTERING GRAPHICS FROM THE KEYBOARD IS NOT ENOUGH !!
EASY USE OF GRAPHICS REQUIRES DRAWING ROUTINES NOT FOUND
IN TEXT EDITORS. ONLY CRAYON HAS ALL THE NEEDED FEATURES!

- 1.) TYPESET LOGO'S - LETTERHEADS - ENVELOPES - BUSINESS
CARDS AND OTHER OFFICE FORMS. THIS AD WAS TYPESET
FROM AN MX-80 PRINTOUT THEN SHRUNK. COST = \$4.50
IF AD WAS TYPESET AT A PRINTSHOP THE COST = \$200 +
- 2.) CREATE AND RUN REAL CARTOONS WITH CRAYON AND THEN
RUN YOUR CARTOONS FROM BASIC AT ASSEMBLY LANGUAGE
SPEEDS. SPEEDS OF 35 FRAMES/SECOND POSSIBLE. USE IT
TO DESIGN DISPLAYS FOR USE IN BASIC & ASSEMBLY PROG'S
- 3.) MANAGE DISKETTE DIRECTORIES, PRINT THEM, SEARCH THEM,
COMMENT THEM. MOD 3 DIR. WORKS ON A TRSDOS SYS. ONLY.
- 4.) DRAW ANYTHING YOU DESIRE ONTO THE SCREEN AND PRINT IT
OUT OR SAVE IT TO DISK/TAPE - UP TO 30 SCREENS/FILE.
- 5.) MANAGE AN APPOINTMENT SCHEDULE,KEEP RECORDS,LISTS OR
MENU'S. SAVE/RECALL INFORMATION QUICK AND EASY.
- 6.) PERFORM ALL VIDED WORKSHEET FUNCTIONS RIGHT ON SCREEN

- 1.) USER FRIENDLY / 42 PAGE DOC'S,OFFSET PRINTED,INDEXED
 - 2.) NINE CHARACTER USER DEFINED CURSOR. ----->
 - 3.) 16 LETTER COMMANDS FOR GRAPHICS ENTRY.
 - 4.) COPY CHARACTERS IN ANY DIRECTION FAST.
 - 5.) UPPER/LOWER CASE SUPPORT WITHOUT DOWNS.
 - 6.) DO ALL OF THE FOLLOWING ON VARIABLE LENGTH LINES->
COPY-FILL-DELETE-EXCHANGE-MOVE-PULL-UC/LC-INVERT
GRAPHICS-PRINT-JUSTIFY TEXT-BUFFER/RESTORE TO SCREEN.
 - 7.) UTILITIES INCLUDE--> MASK - AUTOMATIC PRINT# NUMBERS
CURSOR LOCATION AND VALUE-3 SELECTIVE CLS'S-PATTERN-
EXTRA BUFFERS-SCREEN OVERWRITE-HEXDUMP-SEARCHES. MORE
 - 8.) FULL DISK / CASS I/O DIR-WRITE-LOAD-APPEND-COPY-KILL
SCREENPRINT- OUTPUTS CODES TO DRIVE ANY PARALLEL PRINTER
PROFESSIONALLY WRITTEN & SUPPORTED-NO BUGS-2 YRS. IN DESIGN
OVER 90 COMMANDS - FAST / EASY / FUN -- ALL MACHINE LANG.
CASS MOD 1+3=\$35.00 / DISK MOD 1 OR 3=\$45.00 10K PROGRAM
WORKS IN 1&K. OR MORE AND ADJUSTS TO MEMORY SIZE CHANGES.
- >>> ADDRESS DEALER INQUIRIES TO INSTANT SOFTWARE <<<
CHECK READER SERVICE OR CALL/WRITE FOR OUR FREE BROCHURE!
CHECKS - MONEY ORDERS - COD'S ACCEPTED SORRY NO CARDS



Using a shadow to put an object in perspective.

A Different Perspective

*Fl. Gilbert Nielsen
Acidos Organicos S.A.
Apartado Postal 14-704
Mexico 14 D.F.*

Perspective drawings are useful tools whether you are designing a new doghouse, redecorating the living room or even planning your company's new buildings. My company assigned me just such a project so I wrote this program to accomplish it.

Since the TRS-80 has poor graphic capabilities I wanted a program that would output a list

of coordinate points that I could plot on diagram paper. Then I would connect the points with straight lines to get the final drawing.

I use the computer's screen in the initial stages to move the object, turn it and change its size in front of an imaginary observer until I find the best point of view. You can do this when you have the object in blueprint or when you have it on the screen in perspective.

The program is uncomplicated and well documented. This made it easy to debug and allows you to tailor it to your own needs.

The program uses simple mathematics to calculate the points for your perspective drawing. When I first tried to write the program, I planned to use the vanishing point concept but each line in the drawing has its own vanishing point and I would have needed an infinite number of these points. Then an idea came to me—a shadow has the characteristics of a perspective.

If you imagine a small lamp fixed to an observer's head, he will be unable to see the shadow

of the object before him, because the object covers its shadow exactly, point by point. The observer has to look in the same direction to see a point on the real object and its shadow representation. Thus, to make a perspective drawing you have to calculate the projection of the object from a given point (the observer) onto a plane.

Figure 1 shows an object A placed in an X, Y, Z coordinate system. The observer is standing on the negative part of the Y-axis looking towards the plane defined by the X-axis and

the Z-axis. To make the calculations, divide the situation into two projections as shown in Figs. 2 and 3. Figure 2 shows the projection of the shadow on the X-axis. $\tan(V) = X_a / (Y_a - Y_o)$ and $\tan(V) = X_s / Y_o$; therefore, $X_s = X_a \cdot Y_o / (Y_a - Y_o)$. In the same way you can calculate the distance SH (the distance from the shadow to the horizon) in Fig. 3. $\tan(W) = (Z_a - Z_o) / (Y_a - Y_o)$ and $\tan(W) = SH / Y_o$; therefore, $SH = (Z_a - Z_o) \cdot Y_o / (Y_a - Y_o)$. The program uses these two equations in lines 1280-1300.

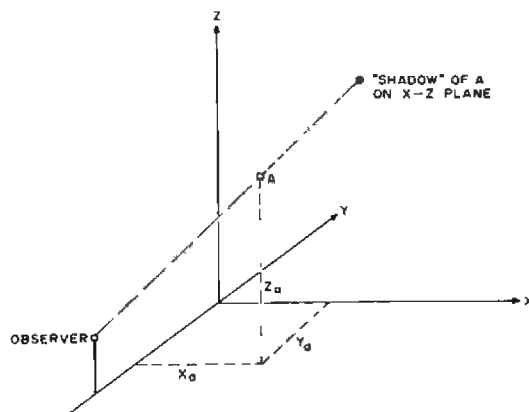

Figure 1

The Key Box

Basic Level II
Model I
16K RAM

I felt, however, that projecting on a spherical wall with the center in the observer must be more correct. This is especially true when you are close and perhaps partly over the object (for example, when landing a Starship on M.S. Enterprise). If you have such plans, delete line 1280 and change lines 1290-1300 in the program listing to:

```
1290 P(N) = 92 * SIN( ATN( ( X(N) - 63 ) / Y(N) ) )
1300 Q(N) = 92 * SIN( ATN( ( Z(N) - 0 ) / Y(N) ) )
```

For most purposes the first projection on a flat wall is more natural, possibly because that is the one we see in photos.

The Program

I wrote the program on a 16K TRS-80 Model I, Level II. The program explains itself and prompts you for the inputs.

During the blueprint mode the center of the coordinate system is placed in the lower leftmost corner with the X-axis pointing to the right, the Y-axis pointing upwards and the Z-axis pointing towards you. Turns in this mode,

as well as turns in perspective mode, are effected around a point in the middle of the screen, marked with an asterisk. The observer is standing on the lower part of the the screen and you must imagine the wall of projection as following the upper edge of the display. (This wall is no limit. You may place your objects in front of it, behind it or crossing it and still get the cor-

rect perspective.) You have 126 units (feet, meters, lightyears and so on) across the screen and 92 from bottom to top.

In the perspective mode the center of the coordinate system is a point in the middle of the horizon line. In perspective mode only defined connections are presented on the screen. Single, non-connected points will not appear until you ask for

the coordinates as the final step of running the program. The display's low resolution will turn the screen all white if you are trying to enter a complicated drawing. Connect the outlines of your object first, and let less important points (corners of windows, doorknobs and so forth) float around as preliminary hidden values in the computer's memory. This procedure

Program Listing.

```
5 CLS
10 CLEAR 200
50 A=100
70 DEFINT N,M,F
80 DIM X(A),Y(A),Z(A),P(A),Q(A)
90 DIM C1(A),C2(A)
95 N1=0:N2=0
100 PRINT"THIS PROGRAM IS FOR DRAWING IN PERSPECTIVE";PRINT:PRINT
110 PRINT"AT FIRST YOU MUST ENTER THE X , Y AND Z COORDINATES FOR"
115 PRINT"EACH POINT."
120 PRINT:PRINT"IF YOU MAKE A MISTAKE ENTER 'AGAIN' AND WHEN YOU FINISH"
125 PRINT"ENTER 'FIN'."
130 N=N1
150 N=N+1
160 PRINT:PRINT"POINT NO.":N
170 INPUT"X ";X$
180 IF X$="AGAIN" THEN 181 ELSE 190
181 FOR M=1TON-1
182 PRINT"POINT";M,X(M),Y(M),Z(M)
183 NEXTM
185 IF N>5 THEN N=N-6:GOTO 150 ELSE N1=0:GOTO 130
190 IF X$="FIN" THEN 300
200 X(N)=VAL(X$)
```

Program continues

**SAVE
TRS-80's**



TRS-80's and Hewlett-Packards

Best Discounts Possible

WE PAY SHIPPING in the 48 continental states on prepaid orders of \$100.00 or more.

NO TAXES are collected on out-of-state shipments.

WE ACCEPT Visa, MasterCard and American Express, or you can save additional money by paying cash.

Pan American Electronics

TOLL FREE ORDER NUMBER 800/531-7466

1117 Conway • Dept. 36 • Mission, Texas 78572
Phone 512/581-2766 • Telex Number 767339

FORT WORTH BRANCH

2912 N. Main • Dept. 36 • Ft. Worth, Texas 76106
Phone 817/625-6333 • Telex Number 794836

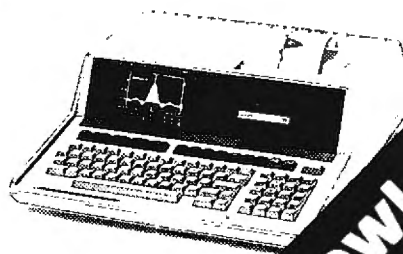

Hewlett-Packard

TM Trademark of Tandy Corporation



122

Program continued

```

210 INPUT "Y ";Y(N)
220 INPUT "Z ";Z(N)
230 GOTO 150
300 N1=N-1:CLS
310 PRINT "NOW ENTER THE POINTS CONNECTED .....":PRINT
320 PRINT "ALSO HERE YOU MAY START OVER TYPING 'AGAIN.'"
330 PRINT "TYPE 'FIN' WHEN YOU FINISH."
335 PRINT:PRINT"MAX. POINT NUMBER IS:";N1
340 N=N2
350 N=N+1
360 PRINT:PRINT"PAIR NO.:";N
370 INPUT "FIRST POINT ";C1$
380 IF C1$="AGAIN" THEN 301 ELSE 390
381 FOR M=1 TO N-1
382 PRINT"CONNECTION NO.:";M,C1(M),C2(M)
383 NEXTM
385 IF M>5 THEN M=N-6:GOTO 350 ELSE N2=0:GOTO 340
390 IF C1$="FIN" THEN 450
400 C1(N)=VAL(C1$)
410 INPUT "SECOND POINT";C2(N)
420 IF C1(N)>N1 OR C1(N)<=0 OR C2(N)>N1 OR C2(N)<=0 PRINT"YOU HAVE USED A
POINT THAT DON'T EXIST.":N=N-1
440 GOTO 350
450 N2=N-1:CLS
460 PRINT"THE PROJECTION OF THE ITEM ON THE X-Y PLANE WILL"
470 PRINT"NOW BE DRAWN AND YOU WILL BE ASKED IF YOU WANT IT"
480 PRINT"RELOCATED AND CHANGED IN SIZE."
485 PRINT"YOU MAY ALSO CHOOSE 'RETURN' TO ADD MORE POINTS AND LINES."
490 PRINT:PRINT"POINT NO.1 IS REFERENCE.(YOU COULD HAVE DEFINED THIS POINT
AS"
495 PRINT"A 'DUMMY POINT' IN ORDER TO CENTER THE DRAWING.)"
500 PRINT:PRINT"BIT ANY KEY TO CONTINUE...."
505 QS=INKEY$:IF QS="" THEN 505
510 G=1:L=1:CLS:GOSUB5000
600 ES=STRING$(63," ")
700 PRINT0,"PLEASE CHOOSE BETWEEN:";
710 PRINT064,"1-MOVE 2-CHANGE SIZE 3-TURN 4-RETURN 5-CONTINUE";
720 INPUT Q
725 IF Q<1 OR Q>5 THEN 740
730 ON Q GOTO 790,900,1000,120,1200
740 PRINT0,ES:PRINT00,"ONLY 1 TO 5, PLEASE...":GOTO 720
790 PRINT0,ES:PRINT00,"ACTUAL COORDINATES FOR POINT 1:";X(1);";";Y(1);
800 PRINT064,ES:PRINT064,"INPUT CHANGE IN COORDINATES FOR THAT POINT:";
810 INPUT X,Y
830 FOR N=1 TO N1
840 X(N)=X(N)+X;Y(N)=Y(N)+Y
850 NEXT N:CLS:GOSUB 5000
860 GOTO 700
900 PRINT00,"INPUT CHANGE IN SIZE AS A NUMBER GREATER";

```

Program continues

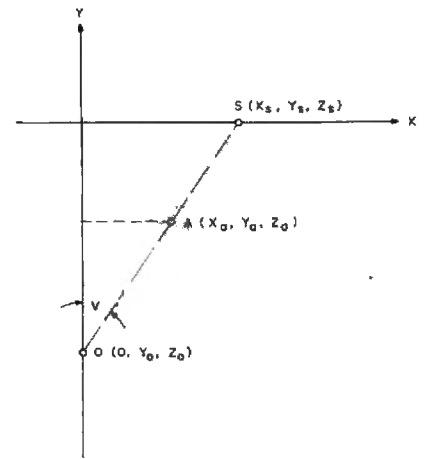

Figure 2

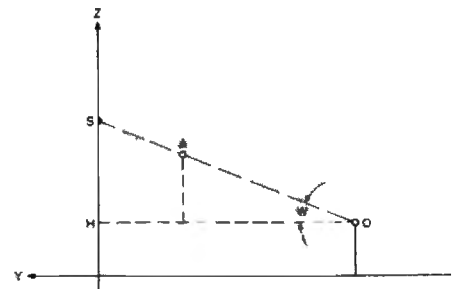
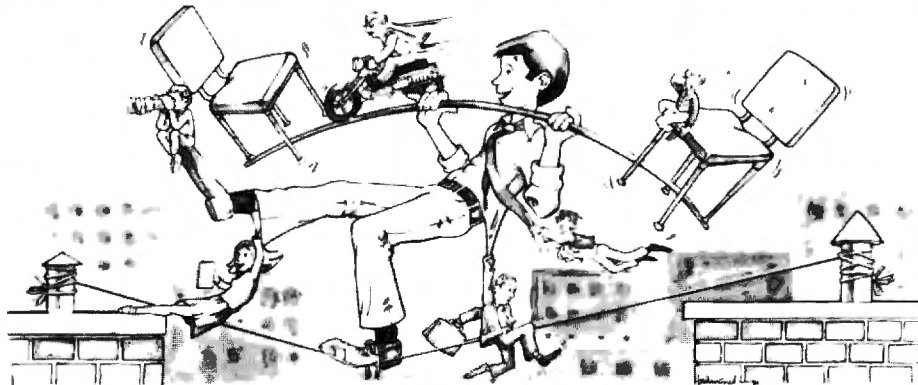

Figure 3

RM/COBOL™1 MAKES IT ACROSS!



**...FROM ONE OPERATING SYSTEM TO ANOTHER!
A VITAL WAY TO PROTECT YOUR SOFTWARE INVESTMENT FOR THE FUTURE!!**

The **RM/COBOL** language runs on more different Operating Systems and more different-sized computers than any other similar language. For starters, it runs on NCR and TI minicomputers and, in the micro field, on the CP/M², MP/M², CP/M-86, MP/M-86, TRSDOS³, OASIS⁴, MOASIS⁴, and UNIX⁵, (ONYX version) Operating Systems ... to mention only a few.

Until now, serious business software of the scope and flexibility seen in the minicomputer world has not been available on micros. **RM/COBOL** now allows transfer of such software with a minimum of fuss.

We have participated in such a mini-to-micro transfer of a major set of general business soft-

ware ... using **RM/COBOL**, as the transfer mechanism, of course. Running on literally thousands of minicomputers, these refined, enhanced, and

RM/COBOL and **(RT)™6** from **CYBERNETICS** ARE GOING STEADY...

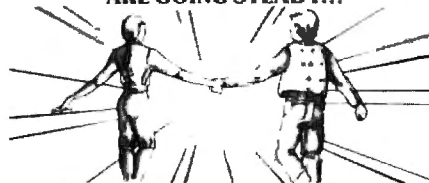

...AND YOU'RE GONNA LOVE 'EM TOO!!

Use your computer to program itself. **(RT)** (Cobol Reprogramming Tool!) from cybernetics is a program generator for **RM/COBOL** that produces error-free **RM/COBOL** source programs for data input, file maintenance, and report printing programs.

A full feature interactive program generator, not a subset! Call Now! 714/848-1922.

proven software packages cover A/R, A/P, G/L, P/R. Order Entry (with Invoicing and Inventory Control) as well as Sales Analysis. The Packages define a new level of achievement for features and flexibility in micro applications software and offer top quality at a reasonable price.

For immediate information, call 714/848-1922 for your complete product description.

Trademarks of:

1-Ryan—McFarland Corp.; 2-Digital Research, Inc.; 3-Tandy Corp.; 4-Phase One Systems, Inc.; 5-Bell Telephone Laboratories, Inc.; 6-Cybernetics, Inc.



8041 NEWMAN AVE., SUITE 208
HUNTINGTON BEACH, CA 92647
714/848-1922

WE WILL NOT BE UNDERSOLD

CP/M® Software	Software/Manual only
Digital Research	
PL/I-80	\$459/\$35
BT-80	\$179/\$30
Mac	\$ 85/\$15
Sid	\$ 65/\$15
Z-Sid	\$ 90/\$15
Tex	\$ 90/\$15
DeSpool	\$ 50/\$10
Micropro	
WordStar	\$319/\$60
Customization Notes	\$489/\$na
Mail-Merge	\$109/\$25
WordStar/Mail-Merge	\$419/\$85
DataStar	\$249/\$60
WordMaster	\$119/\$40
SuperSort I	\$199/\$40
Spell Star	\$175/\$40
Microsoft	
Basic-80	\$289/\$na
Basic Compiler	\$329/\$na
Fortran-80	\$349/\$na
Cobol-80	\$574/\$na
M-Sort	\$124/\$na
Macro-80	\$144/\$na
Edit-80	\$ 84/\$na
MuSimp/MuMath	\$224/\$na
MuLisp-80	\$174/\$na
Organic Software	
Milestone	\$269/\$30
Supersoft	
Diagnostic I	\$ 49/\$20
Diagnostic II	\$ 84/\$20
Disk Doctor	\$ 84/\$20
Forth (8080 or Z80)	\$149/\$30
Fortran	\$219/\$30
Fortran w/Ratfor	\$289/\$35
Unicom	
Mince	\$149/\$25
Scribble	\$149/\$25
Both	\$249/\$50
Data Base	
FMS-80	\$649/\$45
dBASE II	\$595/\$50
Access-80	\$699/\$50
Pascal	
Pascal/MT+	\$429/\$30
Pascal/M	\$189/\$20
Miscellaneous	
SpellGuard	\$299/\$25
SuperCalc	\$269/\$50
CBASIC-2	\$ 98/\$20
MicroStat	\$224/\$25
StatPak	\$449/\$40
Micro B +	\$229/\$20
Apple Software (Business)	
Micropro	
Wordstar	\$289
MailMerge	\$119
Wordstar/MailMerge	\$389
SuperSort I	\$189
Spellstar	\$139
Personal Software	
Visicalc 3.3	\$229
CCA Data Mgr	\$ 84
Desktop/Plan II	\$229
Visiterm	\$139
Visidex	\$229
Visiplot	\$185
Visitrend/Visiplot	\$275
Zork	\$ 34
Miscellaneous	
Micro Courier	\$219
Super-Text II	\$127
ASCII Express	\$ 59

Apple Software (Entertainment)

Wizard & Princess	\$ 28
Mystery House	\$ 24
Flight Simulator	\$ 32
Raster Blaster	\$ 29
Space Eggs	\$ 26
Sargon II	\$ 29
ABM	\$ 22
Pool 1.5	\$ 26
Beer Run	\$ 28
Epoch	\$ 32
Sneakers	\$ 27
Midnight Magic	\$ 32
Wizardry	\$ 45



Apple Accessories

Z-80 Softcard by Microsoft	\$ 299
Keyboard Enhancer	\$ 119
T & G Joystick	\$ 49
Sup-r Mod	\$ 25
CPS Multifunction Card	\$ 199
Videoterm by Videx	\$ 249
16K Card by Microsoft	\$ 159
Sup-r Fan	\$ 39
ALF9 Voice Board	\$ 149
CCS Cards	\$ Call
CCS Parallel Model 7720	\$ Call
CCS Serial Model 7710D	\$ Call
CCS Centronics Model 7728	\$ Call

Disk Drives

For TRS-80* Model 1	
CCI-100 5 1/4", 40 Track	\$ 299
Add-ons for Zenith Z-89	
CCI-189 5 1/4", 40 Track	\$ 455
Z-87 Dual 5 1/4" system	\$ 995
Drives for Z-90	\$ Call
External card edge and power supply included. 90 day warranty, one year on power supply.	

Corvus 5M

Corvus 5M	\$ 3089
Corvus 10M	\$ 4489
Corvus 20M	\$ 5429
Corvus Mirror	\$ 699
Shugart 8" 801R Raw Drive	\$ 399
TANDON 5 1/4" Raw Drive	\$ Call
Power Supplies	\$ Call

Diskettes—Box of 10

Maxell 5 1/4"	\$ 40
Maxell 8"	\$ 45
BASF/Verbatim 5 1/4"	\$26.95
BASF/Verbatim 8"	\$ 36
Plastic File Box—Holds 50 5 1/4" diskts.	\$ 19
Plastic Library Case 5 1/4"	\$ 3
Plastic Library Case 8"	\$ 4
Head Cleaning Diskette	\$ 25
Floppy Saver	\$10.95
Floppy Saver Rings	\$ 6.95
16K RAM Kits	
One Kit	\$19.00
Two Kits	\$37.00
200ns for TRS-80*, Apple II, (specify):	
Jumpers	\$ 2.50

Computer Systems

Atari 400	\$ 359
Atari 800	\$ 699
Call for other Atari products	
Zenith Z89, 48K	\$ Call
Zenith Z90, 64K	\$ Call
Call for other Zenith products	

For fast delivery, send certified checks, money orders or call to arrange direct bank wire transfers. Personal or company checks require one to three weeks to clear. All prices are **mail order only** and are subject to change without notice. **Call for shipping charges.**

Terminals

ADDS Viewpoint	\$ Call
Zenith Z-19	\$ 699
Televideo 910	\$ 595
Televideo 920C	\$ 769
Televideo 950	\$ 969

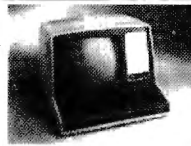

S-100 California Computer Systems

Mainframe	\$ 349
Z80 CPU	\$ 239
64K RAM	\$ 569
Floppy Disc Cntrl	\$ 339
Integrated Sys. w/int. cables, tstd.	\$1975
2P + 2S I/O	\$ 269
4 Port Serial I/O	\$ 249
4 Port Parallel I/O	\$ 179

Casio Calculators

Pocket Comp.	FX702	\$185.00
Desk Printr/Calc.	FR100	\$ 79.95
Scientific Calc.	FX8100	\$ 49.95
Game Watch	CA90 Plastic	\$ 49.95
Game Watch	CA901 Steel	\$ 69.95
Calendar Watch	AX210	\$ 59.95

Printers

NEC Spinwriter	
7710 R.O. Ser	\$2395
7710 Ser w/tr.	\$2595
7720 KSR w/tr.	\$2795
7730 R.O. Par	\$2395
7730 R.O. Par w/tr.	\$2595
NEW 3500 Series	\$ Call

Epson MX-70

Epson MX-70	\$ Call
Epson MX-80	\$ Call
Epson MX-80FT	\$ Call
Epson MX-100	\$ Call
Epson Graftrax	\$ Call
PaperTiger 560 Gr. & 2K	\$ Call
IDS Prism 80	\$ Call
IDS Prism 132	\$ Call
PaperTiger Access.	\$ Call

Anadex DP-8000

Anadex DP-8000	\$ 949
Anadex DP-9500/01	\$1465
Okidata Microline 80 Fric & pin feed	\$ Call
Okidata Microline 82A Fric & pin feed	\$ Call
Okidata Microline 83A 120 cps	\$ Call
Okidata 84 200 cps	\$ Call
Centronics 739	\$ 739
Data South 180 cps	\$ Call

Monitors

Leedex 12" B & W	\$ 119
Leedex 12" Green Screen	\$ 129
Leedex 13" Color	\$ 329
Sanyo 9" B & W	\$ 149
Sanyo 9" Green Screen	\$ 189
Sanyo 12" Green Screen	\$ 249
Sanyo 12" B & W	\$ 239
Sanyo 13" Color	\$ 449
Zenith 12" Green Screen	\$ 129
Zenith 13" Color	\$ 349

***** Special of the Month *****

Olivetti DY 211 Daisy Wheel
\$Call

Telecommunications

Prentice Star Modem 1-yr. guar.	\$ 125
Univ. Data System UDS103LP	\$ 135
Univ. Data System UDS103JP	\$ 189
Novation Cat	\$ 139
Novation D-Cat	\$ 149
Novation Auto-Cat	\$ 199
Novation Apple Cat II	\$ 299
Hayes Smart Modem™	\$ 249
Hayes Micro-Modem II™	\$ 310
Hayes Chronograph™	\$ 225
CCI Telnet Com. Package	\$ 135

DEALER (NATIONAL/INTERNATIONAL) INQUIRIES INVITED

Send for FREE Catalogue

The CPU SHOP

TO ORDER CALL TOLL FREE 1-800-343-6522

TWX: 710-348-1796 Massachusetts Residents call 617/242-3361

420-438 Rutherford Ave., Dept. MC05M
Charlestown, Massachusetts 02129
Hours 9 AM-9 PM (EST) Mon.-Fri. (Sat. till 6)

Technical Information call 617/242-3361
Massachusetts Residents add 5% Sales Tax
Tandy Corporation Trademark™ Digital Research

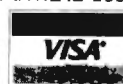

```

910 PRINT@64,ES;:PRINT@64,"OR SMALLER THAN ONE....":INPUT
920 X=X(1):Y=Y(1):L=K*L
930 FOR N=1 TO N1
940 X(N)=K*X(N):Y(N)=K*Y(N):Z(N)=R*Z(N)
950 NEXT N
960 X=X-X(1):Y=Y-Y(1)
970 FOR N=1 TO N1
980 X(N)=X(N)+X:Y(N)=Y(N)+Y
985 NEXTN
990 CLS:GOSUB 5000:GOTO 700
1000 PRINT@0,ES;:PRINT@0,"ENTER POSITIVE OR NEGATIVE ANGEL OF TURN";
1010 PRINT@64,ES;:PRINT@64,"IN DEGREES";
1020 INPUT V
1025 V=V-180
1030 V=V*3.14159/180
1040 FOR N=1 TO N1
1050 X(N)=63-X(N):Y(N)=46-Y(N)
1060 NEXT N
1070 FOR N=1 TO N1
1075 W=X(N)
1080 X(N)=W*COS(V)+Y(N)*SIN(V)
1090 Y(N)=-W*SIN(V)+Y(N)*COS(V)
1100 NEXTN
1110 FOR N=1 TO N1
1120 X(N)=63+X(N):Y(N)=46+Y(N)
1130 NEXT N
1135 IF F=1 THEN F=0:GOTO 1270
1140 CLS:GOSUB 5000
1150 GOTO 700
1200 CLS
1210 PRINT@0,"NOW TO DRAWING THE PERSPECTIVE....";
1220 PRINT@64,"ENTER ALTITUDE OF THE OBSERVER";
1230 INPUT O:O=O*L
1270 FOR N=1 TO N1
1275 IF Y(N)=0 THEN Y(N)=.001
1280 B=92/Y(N)
1290 P(N)=B*(X(N)-63)
1300 Q(N)=B*(Z(N)-0)
1340 NEXT N
1350 CLS:GOSUB 6000
1353 HO=440-64*H
1356 IF HO<64 OR HO>960 THEN 1400
1360 PRINT@HO,"HORIZON ---";
1370 PRINT@HO+57,"-----";
1400 PRINT@0,ES;:PRINT@64,ES;
1410 PRINT@0,"CHOOSE ONE OF FOLLOWING OPTIONS:";
1420 PRINT@64,"1-COORD 2-ALT.OBS 3-SIZE 4-TURN 5-HORI.Z 6-SKETCH 7-END
";
1430 INPUT Q
1440 IF Q>7 OR Q<0 PRINT@0,ES;:PRINT@0,"ONLY ONE TO SEVEN, PLEASE...":GOTO
1420
1450 ON Q GOTO 1500,1600,1700,1800,2000,1900,4999
1500 CLS:PRINT:PRINT:PRINT"THESE ARE THE COORDINATES FOR DRAWING THE PERSPE
CTIVE:";PRINT"(HIT ANY KEY WHEN PROGRAM STOPS)";PRINT
1510 FOR N=1 TO N1
1520 PRINT"POINT NO.":N,INT(P(N)*100+.5)/100,INT(Q(N)*100+.5)/100
1530 IF N>10 THEN 1560
1550 NEXT N
1555 Q$=INKEY$:IF Q$="" THEN 1555
1560 GOTO 1350
1580 Q$=INKEY$:IF Q$="" THEN 1580
1590 GOTO 1550
1600 PRINT@0,ES;:PRINT@64,ES;:PRINT@64,"ENTER NEW ALTITUDE OF OBSERVER:";
1610 INPUT O:O=O*L
1620 GOTO 1270
1700 PRINT@0,ES;:PRINT@64,ES;
1710 PRINT@0,"ENTER CHANGE IN SIZE AS A NUMBER GREATER OR SMALLER";
1720 PRINT@64,"THAN ONE.";
1730 INPUT I
1740 G=C*I:CLS:O=O*I
1750 GOSUB 6000
1790 GOTO 1353
1800 PRINT@0,ES;:PRINT@64,ES;
1810 PRINT@0,"ENTER POSITIVE OR NEGATIVE ANGLE OF TURN:";
1820 INPUT V
1830 F=1:V=V-180:V=V*3.14159/180
1840 GOTO 1040
1900 GOTO 510
2000 PRINT@0,ES;:PRINT@64,ES;
2010 PRINT@0,"MOVE THE HORIZON UP WITH A POSITIVE NUMBER, DOWN WITH";
2020 PRINT@64,"A NEGATIVE (STAY ON SCREEN BETWEEN -7 AND 7)";
2030 INPUT H
2040 GOTO 1350
4999 END
5000 FOR N=1 TO N2
5010 S1=K(C1(N)):T1=Q(C1(N))
5020 S2=X(C2(N)):T2=Y(C2(N))
5030 T1=47-T1/2:T2=47-T2/2
5040 D=SQR((S2-S1)[2+(T2-T1)[2])
5045 IF D=0 THEN D=1
5050 FOR M=1 TO D
5060 S3=S1+M*(S2-S1)/D
5070 T3=T1+M*(T2-T1)/D
5080 IF S3>126 OR S3<0 OR T3>47 OR T3<0 THEN 5100
5090 SET(S3+.1,T3+.1)
5100 NEXTM:NEXTN
5110 PRINT@479,"*";
5120 PRINT@991,"[ :OBSERVER";
5130 RETURN
6000 FOR N=1 TO N2
6010 S1=P(C1(N)):T1=Q(C1(N))
6020 S2=P(C2(N)):T2=Q(C2(N))
6030 S1=S1*G+63:S2=S2*G+63
6040 T1=22-H*3-G*T1/2:T2=22-H*3-G*T2/2
6050 D=SQR((S2-S1)[2+(T2-T1)[2]):IF D=0 THEN D=1
6060 FOR M=1 TO D STEP 2
6070 S3=S1+M*(S2-S1)/D
6080 T3=T1+M*(T2-T1)/D
6090 IF S3>126 OR S3<0 OR T3>46 OR T3<0 THEN 6110
6100 SET(S3+.1,T3+.1)
6110 NEXTM:NEXTN
6120 RETURN

```

will help you to choose the best point of view of your object.

Currently, you may define up to 100 points and connections, but you can change this by letting A in line 50 have another value.

Apart from correcting errors, you can use the Return option in blueprint mode when you want to draw many objects of the same form. You enter the first object, move it to another position, choose the Return option and enter the next using the same coordinates and repeat the procedure.

Be sure no point lines up with or behind the observer in perspective mode. If one does, the shadow will be projected to infinity.

An Example

Draw a box 20 feet long, 10 feet wide and 7 feet high in perspective.

Table 1 lists the coordinates of the corners of the box (with one corner in 0, 0, 0).

Next, move the box to the point 40,40 by going to the menu, selecting the move option and entering 40,40. Next, change the box's size by a factor of 2. Then turn the box around in an angle of 40 degrees and finally move it with -5,0.

Continue in the menu means to prepare for drawing the perspective. The program will ask you: "How tall is your observer?" You may answer any positive or negative number, but if you choose a large one, your object could be drawn outside the screen because the horizon initially is placed in the middle. To move your drawing back to the display choose the menu's horizon-move option.

In this example I chose four (feet) and the drawing satisfied me. At this point you can ask the computer for the coordinates. Table 2 lists the coordinates for this example and Fig. 4 shows the results of plotting those points and connecting them with lines. Figures 5, 6 and 7 show a more complicated drawing.

Future Projects

You can add an option for tilting the object towards you. Since I was dealing with build-

Poor Man's Floppy

HIGH SPEED CASSETTE SYSTEM

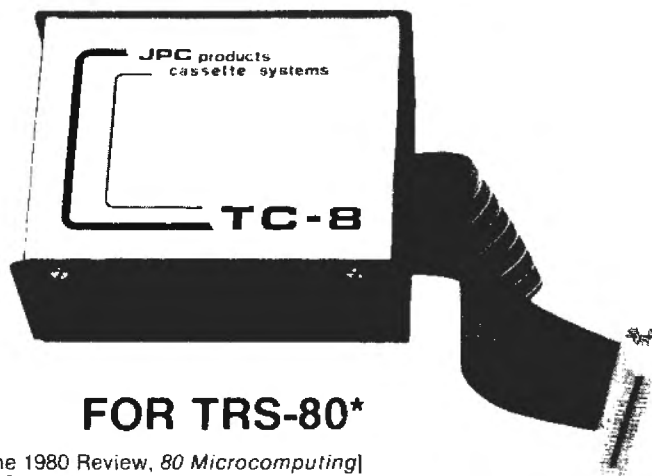

Now the widely acclaimed
JPC Cassette System is available
for your TRS-80* computer.
The price is only \$90.00

TC-8 Cassette System
JPC Products
Albuquerque, NM
Kit: \$90
Assembled: \$120

by Carl A. Kollar

I guess I don't have to tell any TRS-80 owners how frustrating the cassette system that comes with the computer can be. Even with the factory mod that's available, the annoyance of loading and checking programs becomes just barely tolerable.

If you're like me, after you've just plunked down a chunk of money for a Level II 16K machine, "you ain't got nuttin left" for even one disk drive at \$00 bucks apiece. So you suffer.

A reasonable alternative is the Exatron Stringy Floppy (ESF). This will cost you about 250 bucks and totally eliminates your loading and saving problems, automatically and fast. I've had one of these for about six months and love it!

But, if the price is still too steep, have I got a device for you!

The Device

The February 1980 issue of *Microcomputing* had an ad that intrigued the hell out of me. It was a high-speed cassette system by JPC Products acclaimed as a "poor man's floppy." It made all sorts of seemingly ridiculous claims such as "loads five times faster," "stores 50,000 bytes on a 10-minute cassette," "less than one bad load in a million bytes with the volume control anywhere between one and eight."

All this for a measly [90] bucks? How could this be? A call to Albuquerque answered a few questions: Yes, it had its own power supply, and, it stored programs five times faster because it utilized higher density data. The computer outputs the information at a higher rate out of the rear keyboard connector.

The ad had even claimed anyone could build it even if you have never soldered before. JPC would make it work, if you couldn't—for free. I was sold. I placed my order, and it arrived about two months later (parts shortage).

I work in electronics, so I found the unit exceptionally easy to build. It took about an hour. The manual is superb. (That's better than great.) It was clear, concise and exact with no

FOR TRS-80*

[Reprint of June 1980 Review, *80 Microcomputing*]

ambiguities. Important parts placements are stressed (polarity markings on electrolytics, bands on diodes, etc.).

JPC was right! With these instructions, you couldn't go wrong. The board quality is excellent. It is double-sided and parts locations are clearly marked on the component side of the board. There are no jumper wires to install. JPC utilizes PC traces and plated-through holes for connections to traces on the other side of the board.

Also, there are absolutely no adjustments or settings to bother with.

The documentation is a sheaf of 8 1/2 x 11 papers stapled together. It is written in the nicest format I've seen in a while. Each command and/or subject is covered on its own sheet in large type. All explanations are in easy to read English—not computerese.

Commands and Features

SAVE"filename": Saves your BASIC program on cassette.

LOAD: Reads the next BASIC program from the cassette.

LOAD"filename": Searches for and loads the specified file from cassette.

LOAD? and LOAD?"filename": Reads file from cassette, and compares contents to memory.

LOADN: Prints a list of all the programs on a cassette, until interrupted by the "break" key.

LOADN"filename": Same as above except the tape will stop at the end of the program named.

KILL: Removes the file manager program from memory so that the extra memory can be used by large programs.

RSET: Allows the operator to rewind and position the tape on tape recorders that have these functions tied to the motor control jack.

RUN"filename": TC-8 searches for a specified program and runs it immediately.

PUT"filename": Same as SAVE "filename", except it is for use with system tapes.

GET: Same as LOAD, except it is for use with system tapes.

GET"filename": Same as LOAD "filename", except it is for use with system tapes.

GET? and GET?"filename": Same as LOAD? and LOAD?"filename", except it is for use with system tapes.

GETN and GETN"filename": Same as

LOADN and **LOADN"filename"**, except it is for use with system tapes.

OPEN: Required before cassette input or output of a data file can be attempted.

CLOSE: Required to end a cassette data file.

PRINT#: Allows numerical or string data to be output to a cassette file.

INPUT#: Allows numerical or string data to be input from a cassette file.

I haven't counted them, so I don't know about the "one load in a million bytes" claim, but my son, Anthony (age 11), loaded about 30 of his programs from his Radio Shack format tape to a new TC-8 format tape. He's run them all and found no bad loads.

Unlike the standard tape system, you can position your tape anywhere before the program you want and not have to look for a blank spot between programs. The TC-8 patiently waits for the program you want and then starts loading without getting confused by the portion of the previous program you just fed it.

Try that on your regular cassette system; you'll wear out the reset button. ■

ORDER NOW

To order your TC-8 kit, send your check or money order for \$90.00 plus \$3.50 postage and handling to JPC PRODUCTS CO., 12021 Paisano Ct., Albuquerque, NM 87112 (New Mexico residents add 4% sales tax). Credit card orders accepted by phone or mail. Personal checks will delay shipment. We will otherwise immediately ship you the TC-8 kit, the cabinet, the ribbon cable, the power adapter, an instruction manual, and a cassette containing the software.

For Mod I Level II only.



JPC PRODUCTS CO.
Phone (505) 294-4623
12021 Paisano Ct.
Albuquerque, N.M. 87112

ings this was unimportant so I excluded it.

I would like to mount a movie camera in front of the CRT and take single pictures of each display, changing the position of the objects only little by little. Running the movie would then

create illusions like walking around in a small town. An alternative would be to translate parts of the program into machine language.

The current version of the program is the X-ray version where all lines are presented even if, in

real life, the foreground would have covered them. For plotting on diagram paper this is a necessary feature, but if you want to depend more on the screen display, find an algorithm that makes foreground figures cover the background.

Another interesting possibility would be to work backwards from the drawing to the blue-

print. Imagine entering some key points from an old painting. Going backwards in the program (or going forward many times, until the points fit) you would map the surroundings of the artist. You could even tell how tall he was, at least from his feet to his eyes. You could also transform old paintings into three-dimensional pictures. ■

Corner No.	X	Y	Z	
1	0	0	0	
2	20	0	0	For the Bottom
3	20	10	0	
4	0	10	0	
5	0	0	7	
6	20	0	7	For the Lid
7	20	10	7	
8	0	10	7	

Table 1

Point No.	X perspective	Y perspective
1	-43.35	-13.1
2	12.58	-24.15
3	34.19	-16.07
4	-17.52	-10.29
5	-43.35	9.82
6	12.58	18.11
7	34.19	12.05
8	-17.52	7.72

Table 2

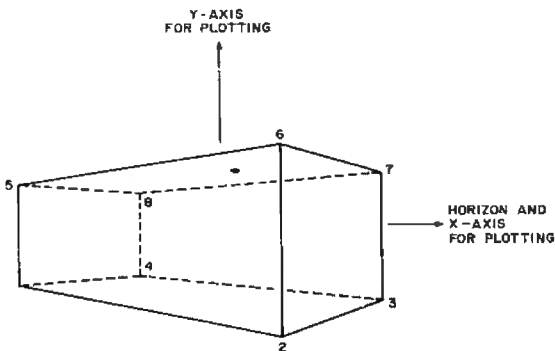

Figure 4

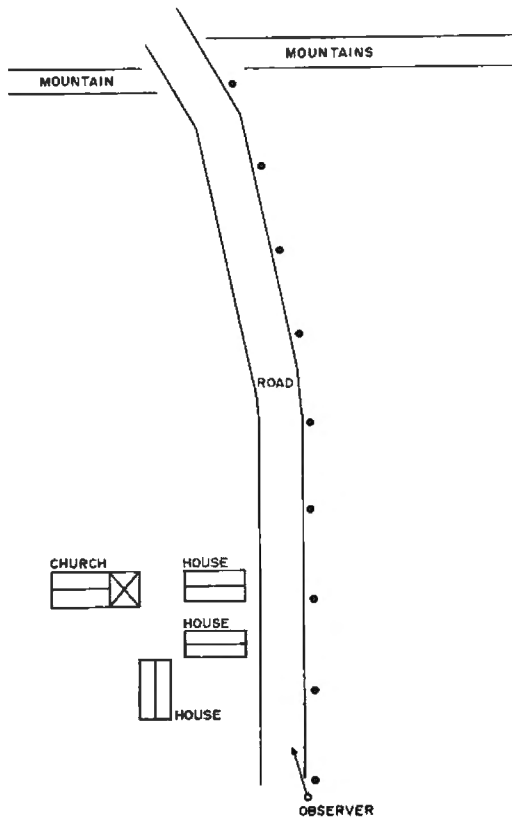

Fig. 5. Blueprint representation

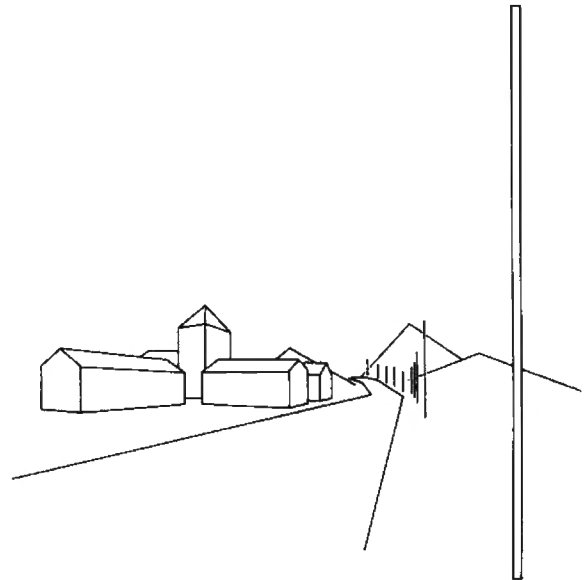

Fig. 6. Projection on flat wall

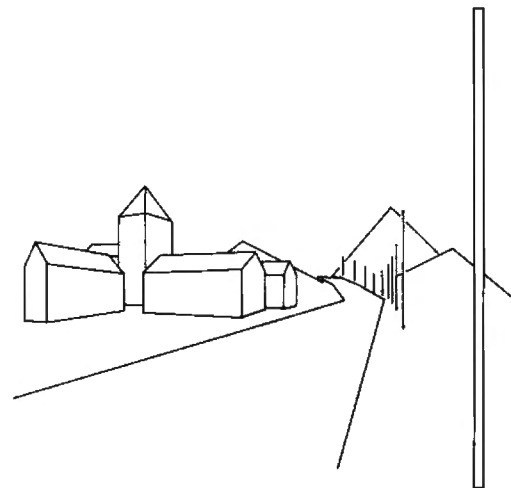

Fig. 7. Projection on spheric wall

Give Your TRS-80* a Tremendous Boost with RACET COMPUTES Software

**RACET COMPUTES Utility Software makes the TRS faster, more efficient,
and easier to use. Our programming aids improve your productivity.
Our reputation is for products that are professional in design
and work as advertised!!!**

FIELD PROVEN

7 1/2 to 30 MEGABYTES On Line for the TRS-80* Model II

Now you can use RACET's HSDS with the ARM Winchester Disk Drive on the Model II. This cost effective combination provides 15 Megabytes per drive including ECC Error Correction Code and an advanced sequencer to further ensure data integrity. An incremental backup to floppy is provided so that only those sectors that were changed from the last backup are saved. A full monthly service contract is available at \$30 per month per drive.

The Hard/Soft Disk System (HSDS) Software has more than One Year's FIELD Experience. The latest HSDS version adds several enhancements including maintenance of system files on the hard drive, files as large as the disk, the ability to segment the disk as logical drives, definable directory size, and many utilities including bulk copies between floppy and hard drives, multiple purge, Superzap, and Directory Catalog System. Full program compatibility with TRSDOS 2.0a is maintained. Mixed floppy and hard drive operation is supported.

HSDS is available for the Cameo, Cynthia Bull, Corvus, Data Peripherals, and Santa Clara Systems hard disk systems as well as the ARM Winchester Drive.

ARM 15 Megabyte Drive Subsystem \$3895 • HSDS Software \$400 • Cameo 5/5 Cartridge Drive Subsystem \$5995 • Cynthia Bull 10/10 Drive Subsystem \$7995

NEW PRODUCT ★ MODEL II FAST BACKUP UTILITY ★ \$75

5 to 10 times faster backups!!! Full disk backup (including verify) 55 seconds!!! on two drive system — 2:15 on single drive system. In business, time is money, and one BACKUP is worth 1000 tears!!

NEW PRODUCT ★ INTEGRATED BUSINESS SYSTEM ★

ISAM File Structure — Multi-Company Capability. Modular structure. Each module includes complete user documentation which guides the user through installation and allows "practice" using a sample data base. When ready, the user simply names his data base and begins.

The Integrated Business System program set includes General Ledger, Accounts Receivable, Accounts Payable, Payroll, Inventory, General Journal, Asset Management and more.

Features include:

- Multiple data base capability
- ISAM file structure
- 500 multi-purpose forms with order
- Menu driven
- Complete end-of-period processing
- Easy to follow installation procedures
- Multi-company
- Rapid response and fast operation
- No need to have preprinted forms
- User friendly data entry screens
- 80- and 132-column printers
- Automated clerical error detection

Business Programs \$250/module Mod III, \$300/module Mod II, \$795 for all four Mod III, \$995 for all four Mod II, General Ledger and Accounts Receivable available now. Accounts Payable and Payroll 1st Quarter 1982.

RACET COMPUTES UTILITIES and PROGRAMMER AIDS

Renodel + Preload for Mod I and III \$35 Renumber utility with partial renumbers, text moves plus tape merge. A must for tape based systems. **Generalized Subroutine Facilities (GSF) Mod I \$25, Mod III \$30, Mod II \$50** The STANDARD against which all other sorts are compared! And then compare price!!! Multi-key multi-variable and multi-key character string sorts. Includes zero and move arrays and sample programs. **DISCAT Diskette Cataloging System Mod I and Mod III \$50** This comprehensive Diskette Cataloging/Indexing utility allows the user to keep track of thousands of programs in a categorized library. Machine language program works with TRSDOS and NEWDOS versions (please specify). Files include program names and extensions, program length, diskette numbers. **COMPROC Command Processor Mod I and Mod III \$30** Auto your disk to perform any sequence of instructions that you can give from the keyboard!! Ideal for setting up dedicated applications. **Infinite BASIC Mod I \$50, Mod III \$60** Extends Level II BASIC with complete Matrix Functions and 50 more string functions. Includes RACET in-memory sorts!! Select only those functions you want to optimize memory. **Infinite BUSINESS (Requires Infinite BASIC) Mod I and Mod III \$30** Complete printer pagination controls, hash codes, binary array search, and packed decimal arithmetic (127-digit accuracy). **Disk Sort/Merge (DSM) Mod I \$75, Mod III \$90, Mod II \$150** All machine language stand-alone Random file sort package. Establish sort specification in a simple BASIC command file. Sorts multiple-diskette files. Only operator action is to switch diskettes when instructed. Super fast sort times — improved disk I/O makes this the fastest Disk Sort/Merge available. **KFS-80 Keyed File System Mod I and III \$100, Mod II \$175** Machine language BASIC ISAM utility provides keyed and sequential access to multiple files. Simple interface to BASIC. Binary tree index system provides rapid access to records. **Utility Package Mod II \$150** Recover blown diskettes. Includes Superzap, bulk copies, and other utilities for repair of blown diskettes. Complete documentation on diskette structure and guidance for repair. Other utilities include Dynamic DEBUG (with single-step, trace, subroutine calling, program looping and more), XCR, DISKID, Directory Catalog System, XPURGE. **Development Package Mod II \$125** Includes RACET Superzap, Apparatus Disassembler and Model II interface to Microsoft's Editor Assembler Plus*. Purchase price includes complete copy of Editor Assembler + documentation for Mod I and uploading service. Assemble directly into memory. MACRO facility, save all or portions of source to disk, extended editor commands. **Basic Cross Reference Utility Mod II \$50** SEEK and FIND functions for variable, line numbers, strings, keywords. *All options available for line number and variables. Load from BASIC — call with control 'R'. Output to screen or printer. **Maillist Mod I and III \$75, Mod II \$150** ISAM-based maillist. Four keys — no separate sorting. Supports 9-digit ZIP code and up to 30 attributes.

CHECK, VISA, M/C, C.O.D., PURCHASE ORDER
TELEPHONE ORDERS ACCEPTED (714) 997-4950

CIRCLE READER REQUEST FOR FREE CATALOG
*TRS-80 IS A TRADEMARK OF TANDY CORPORATION

 RACET COMPUTES LTD.
1330 N. GLASSELL, SUITE M, ORANGE, CA 92667

41

100+ Reasons

DOS FEATURES

- A 252+ page technical manual with index and detailed table of contents.
 - Commands **SYSTEM** and **PDRIVE** allow the user to configure/customize his/her own DOS
 - Depending on installed hardware, **NEWDOS/80**, via the **PDRIVE** command, supports within one system, mixtures of single/double density, single/double head, 5 or 8 inch drives with single/double volume diskettes of up to 7680 standard 256 byte sectors. 80 track drives can read 35/40 track diskettes. Parameters for 10 drives may be pre-specified though only a maximum of 4 are in use at anytime. ADR not provided.
 - LNW 5/8 and Omikron mapper boards supported.
 - APPARAT, AEROCOMP, AM, LNW, and PERCOM, disk doublers supported.
 - Most CPU speed up mods may be used though not specifically supported.
 - Model I/III data diskette interchangeability when both computers are operating under **NEWDOS/80** version 2.0.
 - Model I 2.3 TRSDOS compatible.
 - **COPY** to/from Model I 2.3B and Model III TRSDOS diskettes (no other usage allowed).
 - Single drive **COPY** and Copy By File features.
 - Depending on installed hardware, the system volume may be single/double density, single/double sided, 5 or 8 inch and up to 7680 sectors.
 - **RUN-ONLY** program mode restricts the operator to program defined input only.
 - **MINI-DOS** allows the executing program to be interrupted by the operator to perform one or more of the 51 DOS commands executable under MINI-DOS, and then continue the interrupted program's execution
 - **CHAIN** or **DO** commands activate chaining whereby keyboard input comes from the specified disk file, allowing a pre-determined set of commands and/or parameters to be automatically inputted.
 - Dump display to printer function.
 - Enhanced **DEBUG** facility (14 commands) allows interrupting current program execution, inspecting/altering memory or disk, and resuming execution, continuous or single step, with/without stops.
 - DOS vectors defined for Assembly Language programmers.
 - DOS-CALL allows user programs and BASIC to execute DOS commands.
 - The programmer may create his own resident DOS commands.
 - Programs may enable/disable user routines driven off the timer interrupt.
 - The programmer may create his/her own resident DOS commands.
 - Model I built-in lower case driver, blinking cursor, auto key repeat.
 - **ROUTE**ing of keyboard, display, printer and (Model III only) RS232C. May be routed to a user routine in memory, but not to/from disk unless via a user routine.
 - Except for the spooler, there are no high memory routines for DOS or BASIC, this includes **ROUTE** and **CHAIN** functions.
 - Lower case DOS commands honored.
 - Full error messages displayed instead of error codes.
 - 31 enhanced **COPY** parameters.
 - Copy By File allows 6 criteria for file selection.
 - 15 enhanced **FORMAT** parameters.
 - Partial diskette re**FORMAT** permitted.
 - File **PURGE** by wildcard extents and/or user files.
 - **DIRECTORY** command allows wildcard extents, user files, short or extended format, dump to printer.
 - User may specify diskette's directory location.
 - Expanded directory provides for up to 222 file entries.
 - Some DOS commands may be aborted without reset.
 - **R** command repeats last performed DOS command.
 - **CREATE** command to pre-allocate a disk file.
 - **ERROR** command displays error message associated with error code.
 - **HIMEM** command sets/displays DOS/BASIC high memory address.
 - **DATE** command sets/displays computer's date.
 - **TIME** command sets/displays computer's time.
 - Model III **FORMS** command for printer control.
 - Model III **SETCOM** command for RS232 control.
 - Enhanced **LIST/PRINT** commands for ASCII files with pause, abort and partial file listing.
 - Alter chaining state via the **CHNON** command or commands within the chain file.
 - A program or a chaining sequence may display a message with/without pause.
 - **CLEAR** command to zero memory and to purge routes, user DOS commands and user timer routines.
 - Commands to enable/disable BREAK key, blinking cursor, lower case driver
 - **PROT** command to change diskette **NAME/DATE/PASSWORD**
 - **ATTRIB** command to change a file's attributes.
 - **CLS** command to clear screen.
 - **AUTO** specifies the command to execute automatically at reset/power-on.
 - **SYSTEM** specifies the default system configuration values (usually enable or disable) which become effective on RESET/POWER UP.
- Diskette/file password checking
RUN-ONLY mode
Keyboard debounce (Model I)
Screen dump to printer (JKL)
DEBUG 123 entry
MINI-DOS
Break key as keyboard key
Hardware lower case (Model I)
Assign default drive number for **DIR**
Assign default drive number for file creation
Memory protect value
Clear key as keyboard key
Disk master password required for full diskette or **CBF COPY**
Auto Repeat key function
TIME/DATE question on power-up
TIME/DATE question on reset
Display disabled until operator/program reenables
Manual operator chaining pause/abort
Manual operator **AUTO** command override
R = repeat last DOS command performed
Built-in lower case driver (Model I)
Lower to upper case toggle
Blinking cursor
Number of physical drives on computer
Number of disk I/O retries
Time delay for 1st repeat of auto repeat key
Specify the cursor character
Specify the write of the directory sector's address mark for Model I
single density diskette in Model III format for easy Model I, Model III
diskette exchangeability



Apparat, Inc. 40

800/525-7674 (order line only)
303/741-1778
4401 South Tamarac Parkway
Denver, Colorado 80237

Why **NEWDOS/80™** VER. 2.0 Is the Best DOS for your TRS-80 Model I or III Computer

DISK BASIC FEATURES

- In one statement from DOS READY, BASIC can be brought up, the number of files set, the memory size set and a program LOAded or RUN.
- **RUN-ONLY** prevents the operator from getting to READY or DOS READY, thus giving the program almost total control.
- Via the CMD function, all DOS commands are executable from BASIC, either directly or dynamically.
- **MINI-DOS** is available from BASIC.
- **DEBUG** is available from BASIC.
- **CHAINing** is available from BASIC.
- Variable passing between programs via the **V** parameter of RUN.
- Abbreviated commands:
 - (A)uto; (D)elete; (E)dit or comma; (L)ist or period
- Accidental text line deletion more difficult
- Text line scrolling forward or backward.
- Text page scrolling forward or backward.
- **DI** moves text line to new position
- **DU** duplicates text line to new position
- Built-in **RENUM**ber with line number and limited syntax error check. A portion of text may be moved to another part of the program with all references to that code resolved.
- Built-in **RE**ference function will display/print references to all line numbers, integers and variables. It will display references to a single line number, integer, string, function code (reserved word) or a group of packed or unpacked characters, and then allows displaying of each referencing text line in turn with editing as necessary.
- A program may be loaded into reserved high memory via CMD or **MI**NI-DOS and its execution address extracted from the two bytes at 17411 (4403H).
- **MERGE** functions with packed or ASCII text files.
- Built-in text space eliminator and/or remark deleter.
- Built-in calendar date conversion.
- Dynamic **ERASE** of selected variables, keeping all others.
- Dynamic **KEEP** selected variables. **CLEAR**ing all others.
- After clearing an array via **ERASE** or **KEEP**, the array may be redimensioned via **DIM**.
- Dynamic text line deletion.
- Dynamic text line insertion via **MERGE**, which with dynamic **DELETE**, allows use of overlays.
- **SWAP** contents of 2 variables of the same type.
- Single Stepping starting at specified text line number.
- In-memory sort of up to 9 arrays in either ascending or descending order
- **RENEW** function to reinstate **NEW**ed program.
- Full BASIC error messages, including associate DOS error message, if applicable
- With default start up parameters and no reserved high memory. 48K RAM has 38261 bytes available.
- **SUPERZAP**, **DIRCHECK** and other programs using only memory from 5200H to 6FFFH can be executed directly from BASIC without disturbing the program text or variables (if 8K BASIC free memory available, exclusive of string area)

FEATURES of NEWDOS/80 enhanced BASIC disk file I/O.

- In addition to TRSDOS sequential and random file types, **NEWDOS/80** has two new file types (Marked Item and Fixed Item) divided into five subtypes (**MF**, **MU**, **MI**, **FF** and **FI**)
- These five subtypes do not require **LSET**, **RSET**, **MKIS**, **MKSS**, **MKDS**, **CVI**, **CVS** or **CVD**; instead, **GETs** and **PUTs** are done directly to/from the variables named in a list.
- The string separating character sequence ";", used with **PRINT** is not used with the new file types; instead only a comma is used as the separator.

- **MU** files are used as an option to the older **PRINT/INPUT** files.
- **FF** files are used as an option to the older **RANDOM** files.
- Record lengths up to 4095 bytes supported.
- Records may be all of the same length (**MF** and **FF**), of varying lengths (**MU**) or unknown length (**MI** and **FI**).
- Sequential files may be accessed randomly.
- Files may be accessed by **Relative Byte Address** to allow accessing of variable length or unknown length records.
- Existing files may be extended.

UTILITY PROGRAMS INCLUDED WITH NEWDOS/80

- **SUPERZAP** is a disk/memory display and modification program, also used as the vehicle for installing patches to **NEWDOS/80**.
- **DISASSEM** is a Z80 load module (CMD) disassembler that builds cross reference tables for all location references including those by **JR** instructions, includes in the disassembly printable characters for all hex bytes to help locate character strings and sends the disassembly to the display, printer or a disk file. The disk file can then be edited and/or assembled using **EDTASM**, if it is not too large.
- **DIRCHECK** is a program that displays directory contents and checks directory integrity (its primary function), displaying specific error codes to assist user attempts at directory trouble shooting and/or repair. Optionally will zero out unused (dead) file names.
- **EDTASM** is Apparat's enhancement of Radio Shack's 1978 tape editor/assembler program to operate from disk and with disk files. Requires purchase of that Radio Shack program (not a newer one) as a pre-condition of use of Apparat's **EDTASM**.
- **LMOFFSET** allows load module (CMD) transfer between disk and tape. Displays program start, end and entry addresses. Optionally allows load address relocation (not execution relocation) and subsequent execution as from non-disk BASIC via **SYSTEM**.
- **CHAINBLD** is a mini-text editor for creating/maintaining chaining files.
- **NEWDOS/80** manual chapter titles and page counts
 1. Introduction (5)
 2. DOS Library Commands (52)
 3. DOS Routines (12)
 4. DOS Features (14)
 5. DOS Modules, Data Structures, and Miscellaneous Information (12)
 6. Additional Programs Supplied on **NEWDOS/80** Diskette (22)
 7. Disk BASIC, non-I/O Enhancements (17)
 8. Disk BASIC I/O Enhancements and Differences (21)
 9. Error Codes and Messages (2)
 10. Glossary (9)
 11. Error Reporting, Incompatibility Handling, and Patching (8)
 12. Conversion Information and Miscellaneous Comments (9)
 13. ZAPs (increasing with time)
 14. Appendix A: Marked and Fixed Item File discussion (47)
 15. Appendix B: Marked and Fixed Item File examples (18)
 16. Index (4)
- Full time support staff
- Information, minor enhancements and corrections to **NEWDOS/80** are issued, at no charge, to registered owners only.

NEWDOS/80 Version 2.0 for the model I is a separate and distinct product from the model III. Each is sold separately.

\$149.00

"On-going Support for Microcomputers"





Eliminate those phony ponies.

Computer Racing Form

Ronald H. Bobo
3246 Gravois
St. Louis, MO 63118

I designed "Thoroughbred Handicapping for Profit" to make winning money on horse-races less chancy. The program

The Key Box

Basic Level II
Model I or III

runs on Models I and III TRS-80 but will run on any machine that uses Microsoft Basic with only minor changes. The program can help handicappers recoup the losses incurred annually in the money the track and the state take from betting pools.

Handicapping works like this: The three betting pools on each race are win, place and show. Our illustration considers the win pool.

The "Totalisator," a computer connected to the ticket machines in the sellers' windows, keeps track of all wagers. The amount bet on each horse and the total bet are updated and

displayed on the Tote Board in the track infield about once a minute.

When the windows close just before the race the Tote makes a final calculation of the total amount bet on the race. The legal rakeoff of 18 to 20 percent is deducted from the total and the remainder is divided among the winners in proportion to how much they wagered on the horse.

The place pool is divided in two to pay those holding tickets on the first or second finisher, while the show pool is divided in three.

The successful handicapper must pick enough winners to

stay ahead of the game, and also overcome the percentages. Contrast this with playing blackjack in a casino where the house percentage is much lower.

Winning bets must pay a decent return. You will not break even playing favorites because they win only about one-third of all races. A payoff in the neighborhood of \$2.20 for each two dollars bet on an odds-on favorite loses \$3.80 out of each \$6.00 bet. Any method which picks forty percent winners at a decent return is a moneymaker.

Using the Daily Racing Form
Thoroughbred Handicapping

Program Listing

```
10 CLEAR 300
20 CLS:X=64:Z=64:Y=8
30 SET(X,Y):SET(Z,Y):SET(X-1,Y):SET(Z+1,Y)
40 X=X-1:Z=Z+1:Y=Y+1
50 IF Y=23 THEN 70
60 GOTO 30
70 SET(X,Y):SET(Z,Y):SET(X-1,Y):SET(Z+1,Y)
80 X=X+1:Z=Z-1:Y=Y+1
90 IF Y=47 THEN 110
100 GOTO 70
110 X=20:Z=100:Y=23
120 SET(X,Y):SET(Z,Y)
130 X=X+1:Z=Z-1
140 IF X=41 THEN 160
150 GOTO 120
160 Y=9:X=0:Z=127
170 SET(X,Y):SET(Z,Y):IF Y=47 THEN 190
180 Y=Y+1:GOTO 170
190 X=0:Y=0:Z=47:Q=127
200 SET(X,Y):SET(Q,Z):IF Q=9 THEN 220
210 X=X+1:Q=Q-1:GOTO 200
220 PRINT#65,"THOROUGHbred";:GOSUB 310
230 PRINT#110,"HANDICAPPING FOR";:GOSUB 310
240 PRINT#160,"P";:GOSUB 310 :PRINT#288,"R";:GOSUB 310 :PRINT#
416,"O";:GOSUB 310 :PRINT#544,"F";:GOSUB 310 :PRINT#672,"I";:G
OSUB 310 :PRINT#800,"T";:GOSUB 310
250 PRINT#897,"COPYRIGHT 1988, 1981";
260 PRINT#943,"BY RONALD BOBO";
270 'PROGRAMMED BY RONALD H BOBO, 3246 GRAVOIS, ST LOUIS, MO.
280 '63118 SEPT 1979
290 'VERSION 2.8 AUGUST 1988
300 FOR X=1 TO 2000:NEXT X:GOTO 320
310 FOR X=1 TO 385:NEXT X:RETURN
320 FOR X=968 TO 9 STEP -64:PRINT#X,CHR$(30);:FOR Y=1 TO 18:NEXT
:NEXT
330 PRINT#64,STRINGS(64,CHR$(167))
340 PRINT" THIS PROGRAM IS OFFERED FOR PURELY INFORMATIONAL P
URPOSES,"
350 PRINT" AND NOT AS AN INDUCEMENT TO ILLEGAL WAGERING. IN
```

```
FACT,
360 PRINT" EVEN WHERE OFF-TRACK BETTING IS LEGAL, WE RECOMMEN
D
370 PRINT" THAT ALL WAGERS BE MADE AT THE TRACK IF POSSIBLE,
380 PRINT" SINCE A HORSE THAT LOOKS GOOD IN THE FIGURES MAY S
OMETIMES
390 PRINT" BE ELIMINATED AFTER VISUAL INSPECTION IN THE PADDO
CK OR
400 PRINT" POST PARADE.
410 PRINT
420 PRINT STRINGS(64,CHR$(182))
430 PRINT:FOR X=1 TO 1500:NEXT:PRINT"PRESS ANY KEY TO CONTINUE"
440 AS=INKEYS:IF AS="" THEN 440
470 RS="###"
980 DIM S(41,10),D(46,12),N(16),H(16),HS(16),FC(16),SC(16),F(16)
:RI(16),R2(16),R3(16),RT(16),W(16),BL(16)
990 CLS:PRINT#478,"READING DATA BANK.. "
1000 FOR R=1 TO 41:FOR C=1 TO 18:READ S(R,C):NEXT C,R
1010 FOR R=1 TO 46:FOR C=1 TO 12:READ D(R,C):NEXT C,R
1020 CLS
1030 PRINT#512,"HOW MANY HORSES DO YOU WISH TO RATE IN THIS RACE"
:STRINGS(5,95);STRINGS(5,24);CHR$(15);:INPUT H:IF H<1ORH>16PRIN
T"ERROR - TRY AGAIN":GOTO 1030
1040 FOR N=1 TO H
1050 CLS:PRINT"TYPE NAME OF HORSE #";N;STRINGS(15,95);STRINGS(15
:24);:INPUT HS(N):HS(N)=LEFT$(HS(N),15)
1060 PRINT:PRINT#WAS"HS(N)";"S RACE OVER ONE MILE (Y OR N)";ST
RINGS(4,95);STRINGS(4,24);
1070 INPUT VS:IF VS="Y"THEN 1080 ELSE IF VS="N" THEN 1190 ELSE P
RINT"ERROR - TRY AGAIN":GOTO 1060
1080 CLS:PRINT"INDICATE LENGTH OF RACE BEING USED FOR RATING":PR
INT:PRINT"1 = 1 MI & 40 YDS"
1090 PRINT"2 = 1 MI & 70 YDS":PRINT"3 = 1 1/16 MI":PRINT"4 = 1 1
/8 MI":PRINT"5 = 1 3/16 MI":PRINT"6 = 1 1/4 MI":PRINT"7 = 1 1/2
MI"
1100 PRINT:PRINTSTRINGS(4,95);STRINGS(4,24);:INPUT LR
1110 ON LR GOTO 1120, 1130, 1140, 1150, 1160, 1170, 1180
1120 CO=5:GOTO 1090
```

Program continues

for Profit uses information on past performances in the Daily Racing Form. An abbreviated explanation of the past performance charts appear in each issue; the publisher also puts out a guidebook. A current issue of the Form gives details on how to obtain it.

When you have the Form go through the races at the track where you intend to handicap. Read the conditions of each race printed directly following the number of the race. Eliminate any maiden race unless all the starters have at least two races listed in their past performances. A maiden is a horse which has never won a race; the term has nothing to do with whether said horse is male or female. Some handicappers eliminate maiden races altogether, but doing so eliminates some juicy payoffs. Next, eliminate any steeplechase races and all turf races.

Look through the past performances listed in the first race to be handicapped. Find a race run not more than thirty days before your date, in which the horse made a decent effort, preferably at the track where today's race will be run.

A horse making a decent effort either wins or finishes not more than six lengths behind the winner, or shows early speed, running first or within two lengths of the winner during the first part of the race. A horse running fourth and trailing the leader by six lengths at the stretch call makes a decent effort if it finishes fifth at three lengths behind.

Eliminate any horse not showing one good effort within the past thirty days, except a high class horse who has consistently run in races at a class equal to or higher than today's race and who is making a first start after a long layoff. Some higher class animals can be eased into racing form through workouts alone. If such a horse shows two or three good workouts within the last two weeks, include it in your figures. Rate such a horse from the last good race shown in the past performance, regardless of date.

After reading Data state-

ments into two large arrays, the computer asks the number of horses to be rated in the current race. Enter the number of horses not yet eliminated.

Next, enter the name of horse number one. The computer asks whether the race you are using to rate the horse was over a mile. Answer Y or N. When a list of standard race lengths is displayed indicate the distance of the race.

More Calculations

Since all times given in the Racing Form are to the nearest fifth of a second, convert fractional times to decimal form by multiplying the fractional part of the time by two. Enter 23 4/5 seconds as 23.8.

The computer asks by how many lengths the horse was beaten in this race. If he won, or lost by only a head, enter zero (0). If beaten by a neck, enter .25; otherwise, enter the number of lengths shown in the Form.

The final item is the jockey weight scheduled in today's race.

Once you enter this information, the name of each horse is printed out along with both the pace and speed ratings assigned by the computer. This display is brief, since you need not know the ratings on every horse. The four top contenders are printed in order of pace rating. If the two top contenders are tied, the computer suggests betting on the horse with the higher speed rating.

Mark down these names and ratings, and bet accordingly on that race.

The top contender is your choice unless you spot something negative including, but not limited to, kidney sweat, extreme nervousness, and puffy bandages on the legs accompanied by a limp. If you see any of these signs, bet on the next horse on the list. This program blends the two schools of handicapping thought into one winning method (both speed and animal class figure).

Horses on the pace in a well-run race demonstrate ability repeatable within a reasonable amount of time. Winning form runs in cycles. Horses generally

Program continued

```

1130 CO=6:GOTO 1890
1140 CO=7:GOTO 1890
1150 CO=8:GOTO 1890
1160 CO=9:GOTO 1890
1170 CO=10:GOTO 1890
1180 CO=11:GOTO 1890
1190 CLS:PRINT"INDICATE LENGTH OF RACE BEING USED FOR RATING";PR
INT:"PRINT"1 = 4 FURLONGS":PRINT"2 = FIVE FURLONGS":PRINT"3 = 5 1
/2 FURLONGS"
1200 PRINT"4 = 5 3/4 FURLONGS":PRINT"5 = 6 FURLONGS":PRINT"6 = 6
1/2 FURLONGS":PRINT"7 = 7 FURLONGS":PRINT"8 = 1 MILE"
1210 PRINT:PRINTSTRINGS(4,95);STRINGS(4,24);:INPUT LR:CLS
1220 ON LR GOTO 1230 , 1240 , 1250 , 1260 , 1270 , 1280 , 1290 ,
1300
1230 CO=2:GOTO 1310
1240 CO=3:GOTO 1310
1250 CO=4:GOTO 1310
1260 CO=5:GOTO 1310
1270 CO=6:GOTO 1310
1280 CO=7:GOTO 1310
1290 CO=8:GOTO 1310
1300 CO=9
1310 PRINT:PRINT"ENTER FRACTIONAL TIME CALLS AND FINISH TIME OF
LAST RACE.
USE DECIMAL FRACTIONS, E.G. 23 4/5 WOULD BE ENTERED AS 23.8,
1:22 1/5 WOULD BE ENTERED AS 122.2"
1320 PRINT:PRINT"FIRST CALL";STRINGS(6,95);STRINGS(6,24);:INPUT
FC(N)
1322 PRINT"SECOND CALL";STRINGS(6,95);STRINGS(6,24);:INPUT SC(N)
1324 PRINT"FINISH CALL";STRINGS(6,95);STRINGS(6,24);:INPUT F(N):
PRINTTAB(55);"WORKING..."
1330 FOR R=1 TO 41:FOR C=1 TO CO
1340 IF FC(N)=S(R,C) THEN R1(N)=S(R,18):GOTO 1360
1350 NEXT:NEXT
1360 FOR R=1 TO 41:FOR C=1 TO CO
1370 IF SC(N)=S(R,C) THEN R2(N)=S(R,18):GOTO 1390
1380 NEXT:NEXT
1390 FOR R=1 TO 41:FOR C=1 TO CO
1400 IF F(N)=S(R,C) THEN R3(N)=S(R,18):GOTO 1420
1410 NEXT:NEXT
1420 RT(N)=(R1(N)+R2(N)+R3(N))/3:CLS
1430 PRINT:PRINT"ENTER NUMBER OF LENGTHS ";HS(N);" WAS BEATEN IN
THIS RACE":PRINT" IF ";HS(N);" WOVN ENTER 0 , HD=0 , NK=.25"
1440 PRINT:PRINTSTRINGS(4,95);STRINGS(4,24);:INPUT BL(B)
1450 RT(N)=RT(N)-BL(N)
1460 PRINT:PRINT"ENTER WEIGHT ";RS(N);" IS TO CARRY IN TODAY'S R
ACE"
1470 PRINT:PRINTSTRINGS(5,95);STRINGS(5,24);:INPUT W(N)
1480 NEXT N
1490 CLS
1500 PRINT"NAME", "PACE RATING", "SPEED RATING":PRINT
1510 FOR N=1 TO H
1520 PRINTS(N),:PRINTUSING RS;RT(N);
1530 PRINT,:PRINTUSING RS;R3(N)
1540 NEXT
1550 FOR I=1 TO 2000:NEXT
1560 PRINT:PRINT"STARTING SORT..."
1570 M=H
1580 M=N
1590 M=INT(M/2)
1600 IF M=0 THEN 1760
1610 J=1:K=M-M
1620 I=J
1630 L=I+M
1640 IF RT(I)>RT(L) THEN 1720
1650 TR=RT(I):RT(I)=RT(L):RT(L)=TR
1660 KS=HS(I):HS(I)=HS(L):HS(L)=KS
1670 RR=R3(I):R3(I)=R3(L):R3(L)=RR
1680 WR=W(I):W(I)=W(L):W(L)=WR
1690 I=I-M
1700 IF I<1 THEN 1720
1710 GOTO 1630
1720 J=J+1
1730 IF J>K THEN 1590
1740 GOTO 1620
1750 N=H
1760 CLS:PRINT
1770 PRINT:PRINT:PRINTTAB(22)"FOUR TOP CONTENDERS":PRINT
1780 PRINT"NAME", "PACE RATING", "SPEED RATING"
1790 FOR I=1 TO 4
1800 PRINTS(I),:PRINTUSING RS;RT(I);
1810 PRINT,:PRINTUSING RS;R3(I)
1820 NEXT I
1830 IF W(1)>120 THEN PRINT"CAUTION!! TOP RATED HORSE IS CARRYI
NG MORE THAN 120 POUNDS! DO NOT BET ON THIS RACE!"
1840 IF RT(1)=RT(2) AND R3(1)=R3(2) AND W(1)<120 AND W(2)<120
THEN PRINT:PRINT"PACE RATINGS TIED. BASED ON SPEED RATING, "H
$(2)" WOULD APPEAR TO BE THE BETTER BET."
1850 IF RT(1)=RT(2) AND RT(1)=RT(3) AND R3(1)=R3(2) AND R3(1)=R3
(3) AND W(1)<120 AND W(2)<120 AND W(3)<120 THEN PRINT:PRINT"PA
CE RATINGS TIED. BASED ON SPEED RATING, "H$(3)" WOULD APPEAR
TO BE THE BETTER BET."
1860 PRINT:PRINT"WANT TO FIGURE ANOTHER RACE (Y OR N)";STRINGS(3
,95);STRINGS(3,24);:INPUT AS
1870 FOR N=1 TO H:HS(N)=":RT(N)=0:R3(N)=0:W(N)=0:NEXT
1880 IF AS="Y" THEN 1820 ELSE IF AS="N" THEN 1882 ELSE IF AS<>"R
H" THEN 1860 ELSE CLS:PRINTCHR$(23);PRINT00;"THIS PROGRAM COPYR
IGHT":PRINT090,"1988":PRINT0156,"BY":PRINT0210,"RONALD BOBO":PRI
NT:PRINT
1881 PRINT0324,"UNAUTHORIZED REPRODUCTION":PRINT0412,"IS":PRINT0
450,"STRICTLY PROHIBITED":PRINT0524,"UNDER PENALTY OF":PRINT06
04,"LAW"
1882 END
1890 CLS:PRINT:PRINT"ENTER FRACTIONAL TIME CALLS AND FINISH TIME
OF LAST RACE.
USE DECIMAL FRACTIONS, E.G. 23 4/5 WOULD BE ENTERED AS 23.8,
1:22 1/5 WOULD BE ENTERED AS 122.2"
1900 PRINT:PRINT"FIRST CALL";STRINGS(6,95);STRINGS(6,24);:INPUT
FC(N)
1902 PRINT"SECOND CALL";STRINGS(6,95);STRINGS(6,24);:INPUT SC(N)
1904 PRINT"FINISH CALL";STRINGS(6,95);STRINGS(6,24);:INPUT F(N)
1906 PRINTTAB(55);"WORKING..."
1910 FOR R=1 TO 46:FOR C=1 TO CO
1920 IF FC(N)=D(R,C) THEN R1(N)=D(R,12):GOTO 1940
1930 NEXT:NEXT
1940 FOR R=1 TO 46:FOR C=1 TO CO
1950 IF SC(N)=D(R,C) THEN R2(N)=D(R,12):GOTO 1970
1960 NEXT:NEXT
1970 FOR R=1 TO 46:FOR C=1 TO CO
1980 IF F(N)=D(R,C) THEN R3(N)=D(R,12):GOTO 1420
1990 NEXT:NEXT
2000 GOTO 1420
2010 DATA 21.4,44.2,56.6,103.1,106.108.6,114.6,121.134,100
2020 DATA 21.6,44.4,56.8,103.4,106.2,108.8,114.8,121.2,134.2,99
2030 DATA 21.8,44.6,57.103.6,106.4,109.115,121.4,134.4,98
2040 DATA 22.44,8.57.2,103.8,106.6,109.2,115.2,121.6,134.6,97
2050 DATA 22.2,45.57.4,104,106.8,109.4,115.4,121.8,134.8,96
2060 DATA 22.4,45.2,57.6,104.2,107,109.6,115.6,122,135,95
2070 DATA 22.6,45.4,57.8,104.4,107.2,109.8,115.8,122.2,135.2,94

```

Program continues

No-Nonsense Money-Back 60-day Trial Offer MAS 80 \$489...or

Buy and try the Micro Accounting System General Ledger for \$99. Then within 30 days purchase the total MAS 80 accounting package for \$390, a saving of \$77 over the regular price of \$566. If not satisfied return the package and receive a full refund.

MAS 80 Accounting is a flexible, versatile user formatted business system, designed for the first time computer user. MAS 80 programs run stand alone or coordinating without modifications, they are menu driven with cursor control and full screen instructions, plus two types of file maintenance Regular maintenance—provides maintenance on transactions and account files. Special maintenance—is automatic at the end of posting to insure that posting is correct. Any errors detected are printed, eliminating error searching. Provisions for Single entry or Double entry bookkeeping, with valid account editing and an out-of-balance error detection.

MAS 80 Accounting programs will operate on Mod 1 and Mod III, with 2 or 3 drive versions. MAS 80 also has versions operating on Corvus and Micro Systems hard drives.

MAS offers the best user support for the novice as well as the professional.

GENERAL LEDGER..... \$159.00

- Standard layman format, with screen instructions. Multiple linking MENUS, provide easy operation.
- Post to any of 175 G/L Accounts, you set up yourself (Not Preset Accounts).
- Process transactions in BATCHES of up 150 debit and credit entries, with each batch editing for out-for-balances, then when correct and recorded, answer "Yes" to continue with each batch of transactions
- Transaction UPDATE provides for unlimited transactions. Easy file maintenance.
- Accounts Receivable and Payable coordinating or Stand Alone.

ACCOUNTS RECEIVABLE ... \$159.00

Designed with machine language routines to reduce set-up time, without sacrificing flexibility or requiring professional knowledge of computerized accounting. MAS 80 saves for more efficient management, by providing:

- Balance Forward Systems w/true ageing and multi-function programs. G/L coordinating for Auto-Posting or Stand Alone.
- Post to an unlimited number of General Ledger Accounts with valid G/L and Customer Account # editing per Invoice.
- Process charge entries with detail break down as you choose. Maintenance before and after posting.
- \$700 or more Customers with 1600 or more Unpaid Charge entries. Automatic check to insure proper posting
- Open/Closed or Over Due listings by number of days that you specify
- Two different formats for Billing Statements plus Invoice Printing

ACCOUNTS PAYABLE \$159.00

Features reduce time for more efficient management, by providing

- Balance Forward Systems w/true ageing and multi function programs G/L coordinating for Auto-Posting or Stand Alone.
- Post to an unlimited number of General Ledger Accounts with valid G/L and Vendor Account editing per Invoice
- Process charge entries with detail break down as you choose. Maintenance before and after posting.
- Detailed, Aged, Manage/Report to analyze Liabilities, volume, of purchases, payment choice and discounting
- Will handle 700 Vendor and 1600 Unpaid charge entries
- Check Writing format is standard Moore or Nebs, forms

CHECK REGISTER \$89.00

Here is a Check Register Program that will operate by itself or linked with MAS 80 Accounts Payable and/or General Ledger. This will compile all checks written, allow choice of 26 expense codes for later look up and listing of different categories for tax time. Record deposits and reconcile your check register with your bank statement

- Will handle 600 checks per month. Record deposits.
- Record/Print checks from Accounts Payable and hand written checks
- Print check register, expense codes carries Y-T-D totals.
- File Maintenance—checks—deposits—miscellaneous.
- Account Status—balance, account #, etc.
- Reconciliation—prints a similar form and compare with Bank balance



**The MAS 80 is flexible,
easy to set up and use.
Call or write for sample
reports and full description.**



304 Elati Street
Denver, Colorado 80223
(303) 698-1263
800-525-8394

✓ 16

Program continued

```

1,2,230.2,89
2540 DATA 24.4,47.6,112.4,137.8,140.142,143.8,150,156.4,201.4,23
6,4,88
2550 DATA 24.6,47.8,112.6,138,140.2,142.2,144,150.2,156.6,201.6,
230.6,87
2560 DATA 24.8,40,112.8,130.2,140.4,142.4,144.2,150.4,156.8,201.
8,230.8,86
2570 DATA 25.40,2,113,130.4,140.6,142.6,144.4,150.6,157,202,231,
85
2580 DATA 25.2,48.4,113.2,138.6,140.8,142.8,144.6,150.8,157.2,20
2,2,231.2,84
2590 DATA 25.4,40.6,113.4,138.8,141,143,144.8,151,157.4,202.4,23
1,4,83
2600 DATA 25.6,40.8,113.6,139,141.2,143.2,145,151.2,157.6,202.6,
231.6,82
2610 DATA 25.8,49,113.8,139.2,141.4,143.4,145.2,151.4,157.8,202.
8,231.8,81
2620 DATA 26,49.2,114,139.4,141.6,143.6,145.4,151.6,158,203,232,
80
2630 DATA 26.2,49.4,114.2,139.6,141.8,143.8,145.6,151.8,158.2,20
3,2,232.2,79
2640 DATA 26.4,49.6,114.4,139.8,142,144,145.8,152,158.4,203.4,23
2,4,78
2650 DATA 26.6,49.8,114.6,140,142.2,144.2,146,152.2,158.6,203.6,
232.6,77
2660 DATA 0,50,114.8,140.2,142.4,144.4,146.2,152.2,158.8,203.8,2
32.8,76
2670 DATA 0,50.2,115,140.4,142.6,144.6,146.4,152.6,159,204,233,7
5
2680 DATA 0,50.4,115.2,140.6,142.8,144.8,146.6,152.8,159.2,204.2
,233.2,74
2690 DATA 0,50.6,115.4,140.8,143,145,146.8,153,159.4,204.4,233.4
,73
2700 DATA 0,50.8,115.6,141,143.2,145.2,147,153.2,159.6,204.6,233
.6,72
2710 DATA 0,51,115.8,141.2,143.4,145.4,147.2,153.4,159.8,204.8,2
33.8,71
2720 DATA 0,0,116,141.4,143.6,145.6,147.4,153.6,200,205,234,70
2730 DATA 0,0,141.6,143.8,145.8,147.6,153.8,200.2,205.2,234.2,
69
2740 DATA 0,0,141.8,144,146,147.8,154,200.4,205.4,234.4,68
2750 DATA 0,0,142,144.2,146.2,148,154.2,200.6,205.6,234.6,67
2760 DATA 0,0,142.2,144.4,146.4,148.2,154.4,200.8,205.8,234.8,
66
2770 DATA 0,0,142.4,144.6,146.6,148.4,154.6,201,206,235,65
2780 DATA 0,0,142.6,144.8,146.8,148.6,154.8,201.2,206.2,235.2,
64
2790 DATA 0,0,142.8,145,147,148.8,155,201.4,206.4,235.4,63
2800 DATA 0,0,143,145.2,147.2,149,155.2,201.6,206.6,235.6,62
2810 DATA 0,0,143.2,145.4,147.4,149.2,155.4,201.8,206.8,235.8,
61
2820 DATA 0,0,143.4,145.6,147.6,149.4,155.6,202,207,236,60
2830 DATA 0,0,143.6,145.8,147.8,149.6,155.8,202.2,207.2,236.2,
59
2840 DATA 0,0,143.8,146,148,149.8,156,202.4,207.4,236.4,58
2850 DATA 0,0,144,146.2,150,156.2,202.6,207.6,236.6,57
2860 DATA 0,0,144.4,146.4,150.4,156.4,202.8,207.8,236.8,56
2870 DATA 0,0,144.6,146.6,150.6,156.6,203,208,237,55
    
```

making the next one four dol-
lars. Again a loss, so you bet
eight. You have hit a bad day;
sixteen dollars is called for. You
lose, and bet thirty-two dollars
on the next choice. Your luck is
still bad. The method calls for a
bet of sixty-four dollars, but you
have only thirty-eight dollars
left. The method failed after only
five bets. If you now bet the re-
maining thirty-eight dollars and
lose, you are wiped out after a
string of only six losers.

Now try Conklin's method.
Starting again with one hundred
dollars, the first bet is twenty.
After a loss, you wager one-fifth
of eighty, or sixteen dollars. Los-
ing again, you have sixty-four
dollars left. A fifth of this is
twelve dollars plus change;
since bets may only be made in
multiples of two or five dollars
you bet twelve, leaving fifty-two.
The next bet is ten. Losing
again, you bet eight, leaving
thirty-two dollars in the bankroll.
This is a really miserable day:
You lose once more, and the
next bet is six dollars.

You have made six losing
bets. Using the Martingale
method the sixth bet wiped you
out. Using Conklin's method,
you still have twenty-eight
dollars.

Down to \$28.00

You bet five dollars, one fifth
of twenty-eight and leave twenty-
three. Still on a losing streak,
your next wager is four dollars,
leaving nineteen. You can make
nine two dollar bets and, if they
all lose, you still have a dollar for
carfare. The Martingale method
broke you in a string of six los-
ing bets. You stretched your
bankroll to cover seventeen bets
using Conklin's method of
money management. While you
might have a string of six losers,
the odds are wildly against los-
ing seventeen in a row if you
follow the handicapping prin-
ciples in this article.

No handicapping method can
pick all winners. This method
comes close. It makes horse
racing profitable and enjoyable
because you win a fair share. ■

Accessing the TRS-80* ROM...

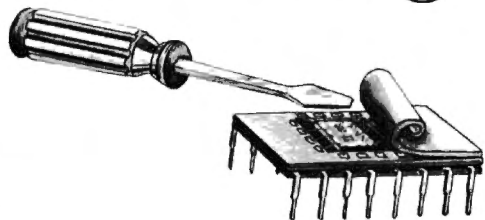

← or →

It's your choice:
do it the hard way, or
get the information you need from

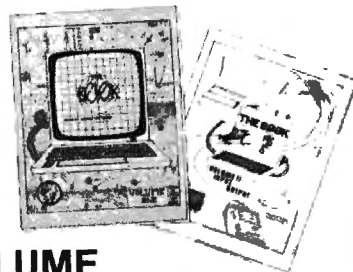

THE BOOK VOLUME I & II

Comprehensive Guide to TRS-80* Assembly Language Routines

Each Volume Priced At \$14.95 Plus \$1.50 Shipping/Handling

VA residents add 4% tax • Foreign: send U.S. funds, add \$4 ea. for overseas delivery

*Trademark of Tandy Corp.

VOLUME I

The most complete book yet on the math routines of the BASIC ROM, Models I & III. Contains a wealth of detail about integer, single and double precision formats, advanced math, data manipulation, and assembly language interfacing, with examples. Includes commented listing (0708H-1607H), plus a highly detailed map of the ROM and reserved RAM.

INSIDERS SOFTWARE CONSULTANTS, INC. ¹²⁶

P.O. Box 7086, Dept. SUM3 • Alexandria, VA 22307

Please send THE BOOK: Volume I Volume II

Name _____

Address _____

City _____ State _____ Zip _____

Enclosed is check M.O. for \$ _____

Charge to my VISA MasterCard Bank Code _____

Exp. date: _____ Card No. _____

Signature _____

VOLUME II

Packed full of useful information on the model I input/output routines, with detailed listings to illustrate the commented source code. Learn to control and manipulate the keyboard, video, printer port, and cassette port. Essential for assembly language programmers, you can write your own routines or use the many programming examples included.

Color computer owners, 32K PLUS DISKS* \$298.00

Yes, that's right - for as little as \$298.00 you can add 32K of dynamic RAM, and a disk interface, to your TRS-80 Color Computer! If you just want the extra memory it's only \$199.00, and you can add the disk interface later for \$99.00.

Just plug the *Color Computer Interface (CCI)*, from Exatron, into your expansion socket and "Hey Presto!" - an extra 32K of memory. No modifications are needed to your computer, so you don't void your Radio Shack warranty, and Exatron give both a 30 day money-back guarantee and full 1 year repair warranty on their interface.

The *CCI* also contains a 2K machine-language monitor, with which you can examine (and change) memory, set break-points, set memory to a constant and block-move memory.

So what about the *CCI Disk Card*? Well as we said it's only an extra \$99.00, but you'll probably want Exatron's *CCDOS* which is only \$29.95 unless you want to write your own operating system. The *CCI Disk*

Card uses normal TRS-80 Model I type disk drives, and *CCDOS* will even load Model I TRSDOS disks into your color computer - so you can adapt existing TRS-80 BASIC programs.

As a further plus, with the optional *ROM Backup* adaptor, you can dump game cartridges to cassette or disk. Once the ROM cartridge is on cassette, or disk, you can reload, examine and modify the software. The *ROM Backup* adaptor is only \$19.95.

For more information, or to place an order, phone Exatron on their Hot Line 800-538 8559 (inside California 408-737 7111), or clip the coupon.



excellence in electronics

exatron

DEALER ENQUIRIES INVITED

Exatron, ✓ 94
181 Commercial Street,
Sunnyvale, CA 94086



- Please send a 32K Color Computer Interface for \$199.00
- Please send a CCI Disk Card for \$99.00
- Please include CCDOS and manual for \$29.95
- Also include a ROM Backup adaptor for \$19.95

Please add \$5.00 for shipping to all orders, and 6 percent sales tax in California.

Name

Address

City

State Zip

Charge my:

MasterCard Interbank Code

Visa Expiration Date

Card

Check enclosed for

Ship COD (\$2.00 extra)

Signature

What those error messages really mean!

Out of Thin Error

Richard S. Adcock
141 NW Lorna
Burleson, TX 76028

Establishing a working relationship with my Model I might have been easier had I read the manual. I ran a lot of code through the computer before discovering the error messages flashing at me were predefined. In the meantime, however, I had compiled a list of what I decided the error messages must mean. In comparing my list with the Level II Basic Reference Manual Appendix, I discovered, to my horror, the writers at Radio Shack made some terrible mistakes. To help the TRS-80 programming public, I decided to publish the real meanings of the error codes. I have no doubt the list will make your debugging efforts a good deal easier.

Explanation of Error Messages

NF—Not Fair, flashes anytime you take advantage of the com-

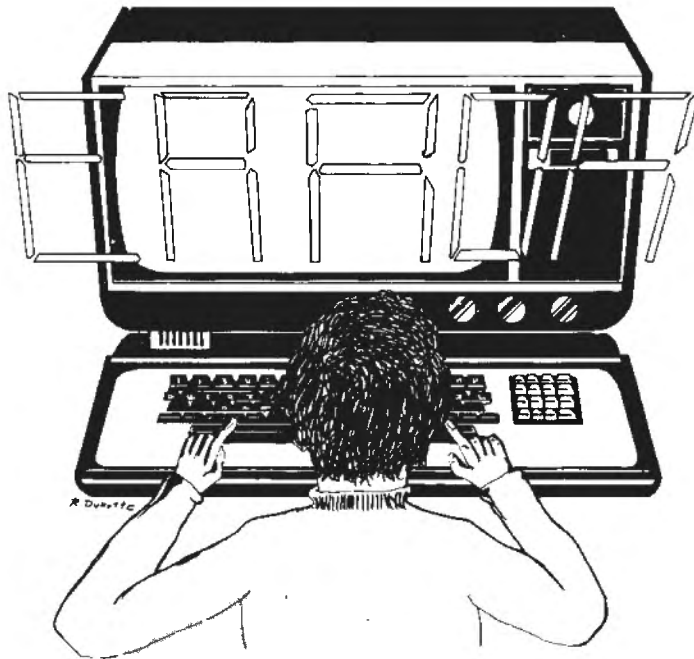

puter's vulnerability to power failure. You will see it flash as you accidentally turn the power off when the computer happens to be winning. It will only stay on the screen until the power supply capacitors lose their charge.

SN—Since Never, flashes when you create an endless loop. Since the loop never ends the

computer believes there must be an error.

RG—Runs Good. This message, demonstrating computer clairvoyance, occurs when an exceptionally long program works the first time. Invariably the media on which you save the program will self-destruct, forcing you to retype. Without question, this

second typing will save perfectly, but will be as buggy as a South American jungle.

OD—Odd Disease. You have created a bug the likes of which the computer has never before encountered.

FC—First Child. This is not really an error message. It is rather like playing an adventure in which the computer offers to sell a clue for a few points. Here the computer is offering to help you debug an error, but since programming is more serious than winning an adventure game, the computer responds accordingly.

OV—Over Voltage, added to the computer's list shortly after TRSDOS became available for the Model I. The historically versed user will recall that the release of TRSDOS was coincidental with a period of extremely flaky power.

OM—Out of Mind. The reference manual calls this an Out-of-Memory error, actually pretty close. The true meaning of this error is ambiguous; it either

refers to a glitch in the machine or is a response to something the programmer has asked the computer to do.

UL—Underwriter's Laboratories, usually refers to an odd modification the user has made to the computer's power supply.

BS—Beyond Stupidity. Most programmers feel this message is the computer's idea of a mildly

sage is elicited by some odd command you have given. The computer wants you to play Russian Roulette with an automatic pistol.

ST—Start Error. The computer is telling you this was your first mistake. You have two more chances before seeing the FC message.

CN—Care Not. Indicates you pushed the computer past the

"... release of TRSDOS was coincidental with a period of extremely flaky power."

obscene comment. They are fooling themselves. It is a caustic comment about your code.

DD—Double Dead. An error message indicating the computer has just killed both your work disk and your backup. Do not be smug. Even though your backup was not in the computer, it has still bit the dust.

/0—Slash Zero. The computer was trying to make its output look sleek by adding slash marks through the zeros. It sadly muffed the effort. This error is as much an apology as anything else.

ID—Identification. The computer does not recognize you and demands to know what you have done with its true owner. Often this message occurs shortly after a series of OM messages.

TM—Totally Misplaced. The computer has lost all your variable pointers or all your variables. In either case, the effect is the same.

OS—Out of Sight. If the computer is in a joking mood it will spontaneously print the OS message followed by an OM message. When serious, this message means the light pen is not hooked up.

LS—Last Shot. This biting mes-

sage is elicited by some odd command you have given.

NR—Never Return usually follows a CN error. The computer has wandered off into the ozone. You may have to buy another machine.

RW—Running Wild. If your computer is literate, it has read the book by the same name and is trying to intimidate you. This message also indicates the computer is locked into several simultaneous endless loops.

UE—Unprintable Error. This is one instance where the reference manual is correct in name. As to the cause of this error, due to publishing restrictions...

MO—The computer is having trouble with its random number generator. During a debug operation, the computer has made it through eeny, meeny and miney, and is hanging only on its last choice.

FD—Found Dead usually follows an LS message. The error which precipitates this message occurs with novice programmers prone to taking the computer a bit too seriously.

There you have it. I hope this amended list proves as valuable in your programming efforts as it has in mine. ■

ComSoft

MEANS BUSINESS

Hardware and Software

Products for the TRS 80®
Models I & III

DBM 5

A Data Base For All Seasons
The File Clerk
for the
TRS 80® Models I & III

- VERSION 5.5 SPECIFICATIONS**
- A multi-feature file manager
 - Plus a simple data base (multi-file data sets)
 - Up to 20 user defined fields
 - File handling capacity for up to 12000 records
 - Files extend across multiple diskettes
 - Automatic DISK MOUNT requests
 - Assembly language sorts on single and combined data fields
 - Multiple search criteria parameters
 - Fast (KSAM) record retrieval on sorted keys
 - Flexible REPORT GENERATOR
 - User titles and pagination
 - Computed Fields
 - 140 page MANUAL

- DBM5 provides three data management features:
- A comprehensive file manager for defining your records, data entry, or edit and general record retrieval
 - A flexible report generator for information retrieval
 - A simple data base is provided for more advanced applications where data sets involving file pairs can be defined

PRICES

#DB 5I	\$99 (MOD I)
#DB 5II	\$99 (MOD III)

AMS1.0

Apartment Management System

Efficient Property Management
General Ledger Compatibility

PRODUCT BRIEF

Written by a CAP for his own property management company, this menu driven system provides a practical, proven method for efficiently managing rental property

- REPORTS**
- LATE RENTS** Lists tenants apt # amount of rent due date rent was due number of days late payments on account
 - VACANT APARTMENTS** List appts description of unit date vacated number of days vacant
 - SCHEDULE OF RENTS** Lists tenants names (up to 4 per apt) type of unit amount of rent and other charges and the last month rent was paid
 - SECURITY DEPOSITS** held by apartment
 - LEASE EXPIRATIONS** of all units in order of expiration
 - RENT INCREASES** lists date of last increase plus current information
 - ALPHABETICAL** listing of all tenants in building
 - MAILING LABELS** for all tenants

This apartment management system is a complete package designed to promote ease of management. The reports listed can be run at any time so there is no delay on checking tenants or obtaining any other information desired.

Requires Model I and 132 column printer
Maintains up to 300 UNITS per diskette

PRICES

#AMS III	\$395
Manual Only	\$ 30

VIEW \$29.00

A SCREEN FORMATER FOR DBMS

- Full CURSOR control
- Protected fields
- User form DESIGN
- File data entry inquiry & edit
- Elegant & professional look
- Flashing messages
- Creates formal and random data files for DBMS
- Includes DBM5 last(KSAM) master key
- View is a compiled basic program
- Basic source code is included

TRS 80 is a Tm of Radio Shack Tandy Corp
NEWDOS80 is a Tm of Apparat Inc
TRS232 is a Tm of Small System Software Co

ComSoft
203 Arden Street
Glendale California 91203
(213) 649-0369



AT LAST! A serial im
Dui output interface
designed for connection
to the TRS80 Model I with
or without an expansion
interface

**SERIAL I/O
MPR-232**

- MPR2321 Specifications**
- Glitch free operation
 - Connects with card edge connector
 - Baud rates 75-19 200 are switch selectable
 - Integral Power Supply included
 - May be daisy chained with other MPR 232s
- The MPR 2321 is compatible with Model I software including TSHARE Specify Model I or III

PRICES

#MPR2321	Assembled and Tested	\$129 00(MOD I)
	PC Board Only	\$29 00(MOD I)
#MPR2321II	Assembled and Tested	\$139 00(MOD III)
	PC Board Only	\$29 00(MOD III)

CSTOCK \$79.00

- A) CSTOCK maintains a securities data base**
- Maintains data on up to 3 stock market indexes
 - Weekly Stock Data (Price Vol P/E and Yields)
 - Weekly Stock Option Data (Near mid and Far)
 - Two years of continuous data per stock
- B) CSTOCK is a professional technical analysis tool**
- Stock and market averages highs and lows with respect to any time span
 - Linear regression analysis of stock behavior versus any of 3 market indexes
 - Short term bias computed (stock volatility in terms of market return)
 - Data plotting capabilities for stocks and options
- C) CSTOCK provides a parametric portfolio selection system as an aid in evaluating investment strategies in relation to risk**

TSHARE 2.0 MULTI-USER



TSHARE is a multi-tasking operating system for two users. It patches itself to your NEWDOS or TRSDOS SYSTEM TSHARE allows simultaneous and separate operations for two users within a single computer

AVAILABLE USER MEMORY ABOVE 7F80 HEX

• 32K TRS 80	16K FREE
• 48K TRS-80	32K FREE

TIMESHARING MODES:

- SIMPLEX MODE With TSHARE 1.3 and 2A Only
- STANDARD MODE With All Systems

SUPPORT EQUIPMENT:

- One + Disk Drive
- 32K + Memory

SIMPLEX MODE	STANDARD MODE
• A Printer	• A Terminal
• Smart System Software	• Radio Shack RS 232 or TRS232 interface (optional)
	• Micro Project s MPR-232

EXECUTION SPEED STANDARD MODE:

- (Without Clock Speedup Modes)
- BENCHMARK executed by 2 simultaneous users 37 sec
 - BENCHMARK executed once by standard TRS 80 14 sec

FEATURES:

- Type ahead during Disk I/O (V2 0 Only)
- Communications between users
- Concurrent execution of single program
- Foreground, background task design
- Address up to two printers

PRICES:

#TS 13 for TRSDOS 2.3	\$89 (MOD I)
#TS 13 for NEWDOS 2.1	\$89 (MOD I)
#TS 2A for NEWDOS V1	\$99 (MOD III)
#TS 2B for NEWDOS V2	\$99 (MOD III)
#TS 2BIII for NEWDOS V2	\$99 (MOD III)

It has nothing to do with paint.

Model II Primer

Jesse W. Baker
P.O. Box 145
Fort Kent, ME 04743

The Tandy people say they sell a lot of Model IIs, but from where I sit I sometimes get the impression that I have the only one they ever sold.

Does everyone who has a Model II run *only* the business application programs they bought? Am I the only one who likes to experiment with this machine and make it do things other computers do?

I, too, have bought many programs that I use, but I also modify Basic programs, especially Level II material, to run on my computer. I have had some success but I get bored and northern Maine gets lonely at times.

These tips are for the person who has just bought a Model II and is still mystified by some of its commands. The Model II owner's manual is full of infor-

mation, but it is useless unless you are a professional programmer, though there are some things that you can use and understand if you try.

Skip the first part of the manual that deals with the operating system except for a few library commands and utility programs. Understand the following: Copy copies a file; Dir lists the disk directory; Error displays error messages; Forms sets the printer settings; Free displays disk use map; Help provides help with TRSDOS commands; Kill deletes a file; and Lib displays all library commands.

There are more commands, but unless you are a serious programmer, save your energy. They will frustrate and confuse you. As you gain experience, study the rest as you need them.

There are two very important utility programs: Backup duplicates a disk; and Format prepares a disk to receive data. You can study the remaining utilities as the need arises.

The next section of the manual is on Basic. If you have not used Level II computer Basic, then buy several good books on it, study them, and then go to Model II Basic. Level II Basic and Model II Basic are similar and you will find it easy to write programs with your Model II. David A. Lien's book about Basic and the Level II Basic manual will give you a good foundation.

If you compare the list of re-

served words from both Basics you will find that the Model II has more of them and has omitted some of the Level II words. Most of the missing words deal

with a particular session. You can also unplug the drive cable from the CRT and replace the disk terminator plug. Remember the terminator plug!

***"Before you can store
this program you must
give it a name ..."***

with graphics. The Model II is not a very good machine for graphics. You *can* do graphics with a Model II but it is not easy.

Read the owner's manual but not all at once. Then go back and read it over again. Again and again.

Make backup copies of all your disks. Hide them if you want to, but make some with all your work on them. I worked for three months on an educational program that I planned to use in one of my courses, and inadvertently placed other material on the same disk. I was in the final stages of debugging it and now I have to recreate the whole program from scratch. I do not even have a printer copy of it.

Be extra careful if you have expansion drives hooked up. Turn the expansion unit on *before* you load a disk into drive 0. Otherwise you will destroy that disk and never be able to access any information you have on it. Turn it on even if you do not plan to use it during that par-

Next, buy and use a disk drive cleaning disk. The inside of the drives get dirty and this can give you trouble with some of your program disks. Have good dust covers to put over your equipment. They are worth their weight in gold. These are tough machines but they have their limits. Reasonable care will keep them running for a long time.

After you have studied the Basic manuals, or if you want to go cold turkey in the Model II Basic, memorize several Basic commands. The first one is how to call up Basic correctly. By correctly, I mean call it up the way you want to use it. If all you want is to play at writing programs and making things happen on the screen, then you key in only Basic, but if you want to use files, follow this procedure: When you are at the TRSDOS READY mode, type in the word BASIC followed by a space, then a hyphen (-), then the letter F, then a colon (:), and then a

The Key Box

**Model II
64K RAM
TRSDOS
1 Disk Drive**



ARCADE CENTER



ALIEN DEFENSE

©1981 Soft Sector Marketing, Inc.
Mod I & III Tape **\$15.95**
Mod I & III Disk* **\$19.95**
Disk Version Talks!

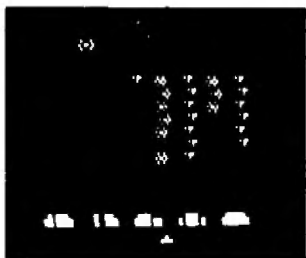

SUPER VADERS

©1981 Soft Sector Marketing, Inc.
Mod I & III Tape **\$15.95**
Mod I & III Disk **\$19.95**
- 2 Player - 10 Levels -

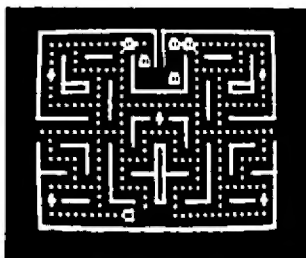

SCARFMAN

©1981 Comsoft Group
Mod I & III Tape **\$15.95**
Mod I & III Disk* **\$19.95**

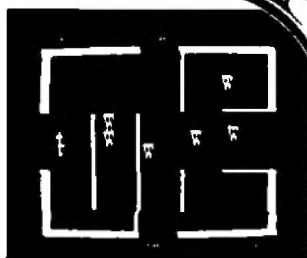

ROBOT ATTACK

by Big 5
Mod I & III Tape **\$15.95**
Mod I & III Disk* **\$19.95**

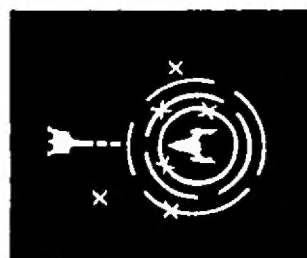

SPACE CASTLE

by Comsoft Group
Mod I & III Tape **\$15.95**
Mod I & III Disk **\$19.95**

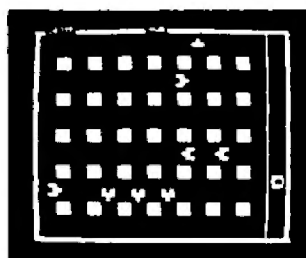

ATTACK FORCE

by Big 5
Mod I & II Tape **\$15.95**
Mod I & III Disk* **\$19.95**



GALAXY INVASION

by Big 5
Mod I & III Tape **\$15.95**
Mod I & III Disk* **\$19.95**



METEOR MISSION 2

by Big 5
Mod I & III Tape **\$15.95**
Mod I & III Disk* **\$19.95**



VOYAGE OF VALKYRIE

by Leo Christopherson
Mod I & III Tape **\$34.95**
Mod I & III Disk **\$39.95**



80 SPACE RAIDERS

by Bosen Electronics
Mod I & III Tape **\$24.95**



DEFENSE COMMAND

by Big 5
Mod I & III Tape **\$15.95**
Mod I & II Disk **\$19.95**



CATERPILLAR

©1982 Soft Sector Marketing, Inc.
Mod I & III Tape **\$15.95**
Mod I & III Disk **\$19.95**

*These versions save high score to disk

SPECIAL DEAL - This Month Only

Purchase 1 Game - List Price / Purchase 2 Games - Deduct 10%
Purchase 3 Games - Deduct 15% / Purchase 5 Games - Deduct 20%
- SPECIAL DEAL applies only to games purchased at one time, and at list price -

84

- DEALER INQUIRIES WELCOME -

SSM SOFT SECTOR MARKETING, INCORPORATED

6250 Middlebelt • Garden City, Michigan 48135
Order Line **800-521-6504**
Michigan Orders & Questions 313-425-4020



PAYMENT - payment accepted by check, money order, or cash. All purchases are subject to credit review. Payment by check is subject to credit review. Payment by money order or cash is subject to credit review. Payment by check is subject to credit review. Payment by money order or cash is subject to credit review.

SHIPPING & HANDLING - Shipping Charges: Items shipped within the continental United States are shipped with shipping and handling charges. Items shipped outside the continental United States are shipped with shipping and handling charges. Items shipped outside the continental United States are shipped with shipping and handling charges. Items shipped outside the continental United States are shipped with shipping and handling charges.

The Quality Continues

ON SALE NOW! MAKE BASIC PERFORM LIKE A CHAMPION



BASIC is not nearly as slow as most programmers think.

BASIC Faster and Better shows you how to supercharge your BASIC with 300 pages of fast, functions and subroutines.

You won't find any trivial poorly designed 'check-book balancing' programs in this book - it's packed with *useful* programs.

Tutorial for the beginner, instructive for the advanced, and invaluable for the professional, this book doesn't just talk... it shows how! All routines are also available on disk, so that you can save hours of keyboarding and debugging.

The #1 disk *BFBDEM* contains all the demonstration programs, and #2 *BFBLIB* has all the library functions.

BASIC Faster & Better is \$29.95, and the two program disks are \$19.95 each.

Get the book and/or disks from your local IJG dealer and B. Dalton bookstores.



1260 W. Foothill Blvd.
Upland, California 91786

(714) 946-5805

number ranging from one to 15 (this number is for the amount of files you want to open; you cannot open more than 15).

For example, type BASIC -F:5. This tells the computer that you want to open five files.

The next command to memorize is Save. This command takes whatever you have written and stores it on the disk. But you must name the program so you can call it back out again by typing the command LOAD.

Suppose you have created a short program such as the following:

```
10 CLS
20 FOR I = 0 TO 1839
30 PRINT CHR$(143);
40 NEXT I
50 PRINT @995,CHR$(32);CHR$(200);
CHR$(32);CHR$(197);CHR$(32);CHR$(204);CHR$(32);CHR$(208);CHR$(32)
60 END
```

Before you can store this program you must give it a name, which Radio Shack Basic will call the filespec. Let's call it Lock-up for fun. To store it on disk type: SAVE"Lock-Up",A.

The computer automatically

creates a file named Lock-Up and puts your data there. Do not leave a space between the word save and the filespec; the commas tell the computer that this is a name and not a command or something else, and the A tells it to store it in ASCII format. If you leave it out the computer uses a compressed format. I suggest that you save everything in the ASCII format. It will make it easier when you start to make your own file formats.

To call this program back type: LOAD"LOCK-UP". Type in this short program and try to save it. To test your success after you have saved it, type in the command NEW which erases everything in the memory, then load the program, and type List which prints the program on the screen. To see what that program does after you load it, just type RUN. ■

Jesse Baker, self-employed, is working on a graduate degree in educational computer curriculum development.

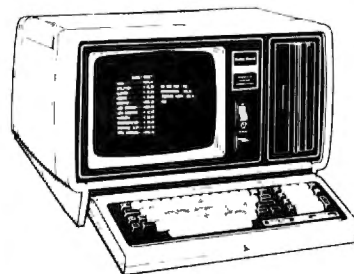

MODEL II USERS

TIRED OF WAITING
FOR DISK FORMATS
AND BACKUPS?

FASTFMT formats and verifies a disk in 43 seconds.

TRSDOS¹ FORMAT takes 2½ minutes.

FASTBAK copies and verifies a full disk in 59 seconds (2 drives).

TRSDOS BACKUP takes 8 minutes.

These utilities make everyday data backups a snap and are distributed on an 8" TRSDOS diskette for systems with 1 or more drives.

\$99.95 plus \$2.00 shipping

VISA/MC

CP/M² SOFTWARE FOR THE MODEL II

Run Model II BASIC and VisiCalc³ under CP/M.

Use the Magic Wand⁴ word processor with the Daisy II printer - bidirectional printing, justified proportional spacing, more

Make fast backups of your P&T and ATON system disks.

Write or phone for details.

¹TRSDOS is a trademark of the Tandy Corp.

²CP/M is a trademark of Digital Research

³VisiCalc is a trademark of VisiCorp

⁴Magic Wand is a trademark of Peachtree Software

The MicroProgrammers

5629 University Way NE
Seattle, WA 98105
(206) 525-1466

UTILITIES

TAPE COPY 2

©1981 Soft Sector Marketing, Inc.

This program will load most any TRS-80 500 Baud system tape (standard Mod I speed) and load it into memory and save it at either 500 or 1500 Baud on the Mod III. NO KNOWLEDGE OF MACHINE LANGUAGE NEEDED. Now it gives you a way to back up a machine language program that loads at the lower speed and makes cassette loading into your new Mod III a much faster, more reliable process. Works with Mod I & Mod III

Only \$14.95

*Mod I loads and saves at 500 Baud only

10% OFF
Any Item on This Page
Only

Super Utility Plus SPECIAL

Was \$125.00 - Now \$50.00

Mod I & III Version

Reduced for Quick Sale!

BUG+

©1981 by James Limkemann

A Self-relocating Machine Language Monitor for MOD I & III

©1981 by J. Limkemann Bug+ is a powerful machine language monitor. The one point most improved over other monitors, is the tape write. Bug+ has the ability to write a "clean" tape (at 500 baud), this tape will read into the TRS-80 under the system command, without the problems previously associated with the volume setting. Regardless what version basic you have or whether or not you have a Radio Shack cassette fix, this monitor will improve the reliability of your cassette by 100%. There is also a verify command that works the same as a "CLOAD?", except when an error is found, the memory address and what is found on the tape is displayed.

Finally a break point that works! When a break point is reached, there is a blinking asterisk in the bottom right hand corner, you are able to see what is on the screen before the monitor takes control. Press the enter key the screen clears and the monitor comes to life. When you continue from a break point, the monitor will restore the screen first then load the CPU registers and return to your program. You do not lose your program on display, and it does work!

Bug+ also has all the commands of T-Bug, they just work better. Bug+ loads into low memory, then relocates itself.

Mod III has all the commands of the Mod I version plus it gives you the ability of reading or writing 1500 baud or 500 baud tapes. You can read at one rate and write at another. Mod I or III 4K both on same tape.

Cassette \$14.95

BOSS III

©1981 Soft Sector Marketing, Inc.

For Mod III

This Machine Language utility is designed to aid you in creating and debugging programs written in BASIC. The utility allows you to trace the program flow, to single step the BASIC program, to observe the conditions of variables during program execution, and to push your basic program on the stack during program development. The utility is known to operate with Mod III, TRS-DOS or Mod III Rom BASIC.

Cassette (goes to disk) \$18.95

The
BASIC
OPERATED
SINGLE
STEPPER

TRS-DOS* COMMENTED

©1982 Soft Sector Marketing, Inc.

Mod III Radio Shack operating system. Comments on every system files, with a chapter on how to use some of the DOS calls.

Fixes for your TRS-DOS users. Helpful reference guide for experienced machine language programmers.

A MUST FOR EVERY MOD III OWNER!

List \$29.95

Introductory Special
\$19.95



ZAPSIT

©1981 by Soft Sector Marketing, Inc.

Written for TRS-DOS & DOSPLUS by Larry Ashmun
Requires 32K Disk - Mod III

Zapsit is a stand alone machine language program that lets you examine, modify, copy disk sectors and much more. It does not use any of the resident DOS routines so that you are not limited to the restrictions of the particular DOS that you normally use. You do not have to have a system disk in DRIVE 0 once Zapsit is running.

Currently there are two versions of Zapsit - one for use with TRSDOS* and one for use with DOSPLUS**. They are the same except in the way that they format a disk and the way that they write DATA ADDRESS MARKS. Because of the differences, they are not interchangeable. Writing to a TRSDOS diskette with the DOSPLUS version (or vice-versa) could make the diskette written too unuseable.

For all disk operations you will be asked a series of questions. Each question can be answered by pressing the ENTER Key or by entering a specific value. Pressing the ENTER Key will cause the DEFAULT value to be used. All default values are indicated on the screen at the time the question is asked.

When entering a specific numeric value it is assumed to be DECIMAL unless and H is appended to the number. When and H is appended, the number is assumed to be hexadecimal (base 16).

CAPABILITIES

Display/Modify Disk Sectors/Memory. Print to screen, print sector to printer. Modify in Hex, Modify in ASCII.

Change Track & Sector Limits. Single density read and write. Double density read and write for 1-80 track, from 0-18 sectors. Single and dual sided drives.

Format a Disk. S=Standard Format W=Format without Erase. If you press ENTER or S you will be asked which drive, what density. After answering these questions Zapsit will format the disk using the parameters specified. As each track is formatted all of the sectors are checked for readability before the next track is formatted. Any unreadable sectors are reported but the operation will not be aborted.

If you type W you will be asked which drive, what density to use and if you want any bad sectors reported to the printer. Before each track is formatted each readable sector on the track is read into a holding area. Unreadable sectors are reported and their holding area is zeroed. After all of the sectors for a track are stored, the track is reformatted and the data in the holding areas written to the appropriate sectors.

Verify a Disk. Verify a disk does just that. It verifies that every sector is readable. Any unreadable sectors are reported. You

will be asked if you want the unreadable sectors reported to the printer. Now you can verify that the format of your diskette is in good shape before you copy your important files to a diskette. This prevents losing your data that you are trying to back up.

Copy Disk Sectors. Copy disk sectors allows you to copy sectors (Single or Double Density) from a disk to different sectors on the same disk. Copy sectors from a Double Density disk to a different Double Density disk. Copy sectors from a Single Density disk to a different Single Density disk. Copy sectors from a Single Density disk to a Double Density disk. Copy sectors from a Double Density disk to a Single Density disk. All copying to a Different disk must be done on a Two Drive System.

Zero Disk Sectors. Zero disk sectors allow you to write a value of your choice to the sectors specified.

Read a Track. Reading a track allows you to read an entire track into memory, with all of the address marks and information that you don't normally see with a sector read. The output can be to either the screen or printer.

List \$24.95 - Introductory Special \$19.95

- DEALER INQUIRIES WELCOME -

SSM SOFT SECTOR MARKETING,
INCORPORATED

6250 Middlebelt • Garden City, Michigan 48135

Order Line 800-521-6504

Michigan Orders & Questions 313-425-4020

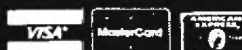

PAYMENT - payment accepted by charge, personal check or C.O.D. only under the following conditions. **Charges Personal**

Checks delay shipping, pending 3 weeks to clear. **C.O.D.**

orders are certified check or cash only, add \$1.50. MI residents must add 4% sales tax.

SHIPPING & HANDLING - Shipping Charges: Send the larger amount, 2% or \$2.50 unless straighted eitherwise. Any order received without shipping and handling will be shipped (freight collect Air Mail Shipping outside of North America, please send the larger amount, 10% or \$10.00. Overpayment will be refunded.

The Quality Continues



Compute your golf handicap—unless your handicap is your swing.

Two Stroke a Side

Michael Avery
Avery Computer Services
315 Logan
Roland, IA 50236

People of all ages and ability levels can enjoy golf. It offers an excellent opportunity to get a moderate amount of exercise and plenty of fresh air. Golf offers a measure of competition not available in most other sports. Although golfers' abilities vary widely, good golfers can compete on an equal basis with golfers of lesser ability by using handicaps.

A handicap is a number reflecting the average score a golfer shoots. When two golfers of unequal handicap wish to compete against each other, the poorer player is awarded a number of strokes equal to the difference in handicaps. This allows the two players to compete on an even basis.

Golf leagues often use handicaps to make weekly matches competitive. To be fair and effective, scores should be up-

dated and handicaps recalculated weekly. The considerable amount of record-keeping and calculation necessary to keep the handicaps current and accurate is usually dumped on the league secretary. I will describe a program that allows the golf league secretary to keep track of the scores of league members and easily update their handicaps.

Handicap Calculation

The number of different ways to calculate handicaps is almost as great as the number of golfers. Some methods are very simple, while others would tax the ability of large business computers. The United States Golf Association (USGA) developed the standard method of computing handicaps. I used the method here in a modified form.

The basis of the USGA method is the golf course rating. This is a numerical rating of the course difficulty. For most cases, this number is very simi-

lar to the course par; in this program I used the course par for the rating.

Once you determine the course rating, you compute a number called a differential for the golfer's scores by subtracting the course rating from each raw score. The USGA method uses the golfer's 20 most recent scores.

Next add the 10 smallest differentials to produce a number that reflects the golfer's average score. Then compare this number to a table to determine the handicap. The look-up table includes factors such as the increased difficulty in lowering one's handicap as the handicap approaches 0.

How to Use the Program

I wrote the program for a 16K Level II TRS-80. After loading the program, typing Run clears the screen and produces program information for the user. Pressing Enter produces the two necessary data entries. You must enter the par for the course here.

If the course is only nine holes, enter the same par for front and back nine. The program is set up for one golf course only. If you are using scores from more than one course, you must use the same par. After you enter the course par, enter the league name. The league name is a header for the handicap display, so no harm will come to the program if you do not give a name (hit Enter).

The rest of the program is menu driven (see Fig. 1). You select program options by entering the appropriate number. See Fig. 2 for examples of typical data entry procedures. All data entries are tested for errors. The menu options should provide the user with all needed manipulations.

When you run the program for the first time you will enter the names of all league golfers. Keep the length of each name to 12 characters or less. Once this is done, you can display or modify scores for each golfer.

Figure 2 also shows the format the program uses to display

"The number of different ways to calculate handicaps is almost as great as the number of golfers."

The Key Box

Basic Level II
Model I or III
16K RAM
Tape or Disk

- (1) Cassette Data Input
- (2) Cassette Data Output
- (3) Add Names
- (4) Delete Names
- (5) Display One Entry
- (6) Update All Scores
- (7) Calculate and Display Handicaps
- (8) Change Data for One Golfer

Figure 1



BUSINESS



LAZY WRITER®

Lazy Writer is the most advanced word processing system on the market for the TRS-80 Mod I & III your money can buy.

Reviewers have stated time and time again that Lazy Writer® is easy to use, the most advanced, and has more features than other systems.

Organized, well-thought-out, add-on options make this program better supported than any other system.

**If you are looking for
The Finest In Word Processing Systems you can . . .**

1. Purchase and examine all other word processing programs on the market, and then purchase **Lazy Writer®** or . . .
2. You can purchase **Lazy Writer®** first. **It's your money!**

Lazy Writer® Mod I or III
\$175.00

*Requires 2 Disk Drives to convert only.

GUARANTEE
If you purchase a Business Program from Soft Sector Marketing, Inc. and for any reason you are not satisfied, you may return (within 30 days of purchase) for a refund (less 10% restocking charge)

**Proportional Spacing Option
Now Available!**
For:
Daisy Wheel II Printer . . . Only \$29.95
Centronics 737/739/LPV . . . Only \$29.95
NEW Epson MX80
with Graffrax Only \$24.95

ELECTRIC WEBSTER Spelling Checker

A product of Cornucopia Software
Son of MICRO PROOF
EASY TO USE

- EASY TO USE
- 50,000 WORD VOCABULARY & EXPANDABLE
- RECOGNIZES PREFIXES & SUFFIXES
- REQUIRES ONLY 32K OF MEMEORY & 2 DISK DRIVES
- AFFORDABLE & AVAILABLE IN THREE FORMS: fully independent program to identify errors; independent program to identify and correct errors; or with a conversion program that will permit ELECTRIC WEBSTER to operate from within.

	Was	Now Only
Basic Electric Webster	\$125.00	\$89.50
with Correcting Feature		\$149.00
Special LazyWriter® Version	\$189.00	\$149.50
with Correcting Feature works from within Lazy Writer®		

THE COMPLEAT IDIOTS BOOKKEEPER

Turn your baskets full of receipts into one super organized group of paper work.

If your income tax was a pain
you didn't have

The Compleat Idiots Bookkeeper!

Mod I & III - **\$49.95**
FREE Overview Available

MAKE V.C.

Changes files to VISI CALC interchangeable format or V.C. file into The Compleat Idiots Bookkeeper readable files.
Mod I & III - Only **\$24.95**

SPECIAL

Purchase The Compleate Idiots Bookkeeper the year-round bookkeeper with outstanding features at regular price and receive Make V.C.
AT NO EXTRA CHARGE
- This Month Only -

- DEALER INQUIRIES WELCOME -

SSM SOFT SECTOR MARKETING, INCORPORATED
6250 Middlebelt • Garden City, Michigan 48135
Order Line **800-521-6504**
Michigan Orders & Questions 313-425-4020



PAYMENT - Payment by check or money order is preferred. If you prefer to pay by VISA or MasterCard, please call for details. All payments are in U.S. dollars only. Payment by check must be accompanied by a return address. Payment by money order must be accompanied by a return address. Payment by VISA or MasterCard must be accompanied by the card number and expiration date. Payment by check must be accompanied by a return address. Payment by money order must be accompanied by a return address. Payment by VISA or MasterCard must be accompanied by the card number and expiration date.

SHIPPING & HANDLING - Shipping Charges: Select the shipping method you prefer. All shipping charges include handling and insurance. Air Mail Shipping: For orders shipped outside of the contiguous United States, please add \$15.00 per order for air mail shipping. Overseas shipping charges are extra. Payment by check or money order is preferred. If you prefer to pay by VISA or MasterCard, please call for details. All payments are in U.S. dollars only. Payment by check must be accompanied by a return address. Payment by money order must be accompanied by a return address. Payment by VISA or MasterCard must be accompanied by the card number and expiration date.

Charges Personal C.O.D.

88

an individual golfer's data. The program saves only 10 scores to minimize memory usage and

cassette storage. Each score is prefixed by F for a front nine score or B for a back nine score.

If 10 scores are on file and you enter a new score, the oldest score is bumped off the list and

lost. The program uses only the most recent scores. This system uses only nine-

Program Listing

```
10 ' *****
20 ' *** GOLF LEAGUE HANDICAP ***
30 ' *** BY MIKE AVERY ***
40 ' *** COPYRIGHT 1981 ***
50 ' *** PROGRAM LENGTH=5.9K ***
60 ' *****
70 ' PROGRAM USE INSTRUCTIONS
80 CLS:PRINT "GOLF LEAGUE HANDICAPER":PRINT
90 PRINT "THIS PROGRAM WILL ALLOW THE GOLF LEAGUE SECRETARY TO KE
EP
TRACK OF THE SCORES OF UP TO 40 LEAGUE MEMBERS. THE HANDICAPS
CAN BE CALCULATED FOR THE MEMBERS AT ANY TIME.":
100 PRINT:PRINT "DATA THAT MUST BE ENTERED IS THE PAR FOR THE PRO
NT AND
BACK NINE AND THE LEAGUE NAME. AFTER ENTRY OF THE
INFORMATION, ALL DATA MANIPULATION IS CONTROLLED USING A
PROGRAM 'MENU'"
110 PRINT:PRINT "FOR CASSETTE STORAGE, A C-20 TAPE WILL STORE 40
NAMES
A C-90 TAPE IS NEEDED TO STORE THE SCORES. IF THE LEAGUE HAS
MORE":
120 PRINT "THAN 40 PEOPLE, SPLIT THE DATA UP INTO GROUPS OF 40,
AND USE ONE SET OF CASSETTES FOR EACH GROUP."
130 PRINT:INPUT "HIT 'ENTER' TO CONTINUE":ANS
140 CLEAR 1000:DIM TM%(20),NAS(50),DI%(50,20)
150 IS="###":FI=1
160 CLS:PRINT"515,";:INPUT"ENTER PAR FOR THE COURSE <FRONT,BACK
>":F9,B9
170 CLS:PRINT"515,";:INPUT"ENTER LEAGUE NAME":LN$
180 ' MENU
190 CLS:PRINT"MENU FOR 'HANDICAP'"
200 PRINT"YOUR OPTIONS ARE:":PRINTSTRING$(64,".")
210 PRINT"1--CASSETTE DATA INPUT"
220 PRINT"2--CASSETTE DATA OUTPUT"
230 PRINT"3--ADD NAMES"
240 PRINT"4--DELETE NAMES"
250 PRINT"5--DISPLAY ONE ENTRY"
260 PRINT"6--UPDATE ALL SCORES"
270 PRINT"7--CALCULATE AND DISPLAY HANDICAPS"
280 PRINT"8--CHANGE DATA FOR ONE GOLFER"
290 PRINTSTRING$(64,".")
300 INPUT"ENTER THE NUMBER OF THE DESIRED FUNCTION":AN
310 IPAN<1 OR AN>8THEN190
320 PRINT"FUNCTION ";AN; " SELECTED, PRESS 'ENTER' TO START, 'N'
TO ABORT":
330 AN$=INKEY$:IFAN$=""THEN330ELSEIF AN$="N"THEN190
340 IF AN=1THENFI=1ELSEIFAN=2THENFI=2
350 ONANGOSUB390,390,840,1650,370,890,1010,650
360 GOTO190
370 CLS:INPUT"ENTER GOLFER NUMBER":I%:IFI%>LN$THEN370ELSE
GOSUB770:PRINT"960,";:INPUT"HIT 'ENTER' TO CONTINUE":
AN$:RETURN
380 ' CASSETTE I/O
390 CLS:ONFIGOTO400,530
400 PRINT"PLACE 'NAMES' TAPE IN RECORDER, REWIND AND HIT 'ENTER'
"
410 INPUTAN$:CLS:PRINT"READING NAMES---PLEASE STAND BY":LN$=0
420 LN$=LN$+1
430 INPUT#-1,NAS(LN%):IF NAS(LN%)="END"THEN 440 ELSE 420
440 LN$=LN$-1
450 CLS:PRINT"PLACE 'SCORES' TAPE IN RECORDER, REWIND AND HIT
'ENTER'"
460 INPUTAN$:CLS:PRINT"READING SCORES---PLEASE STAND BY"
470 FORI%=1TOLN$
480 FORJ%=1TOL0
490 INPUT#-1,DI%(I%,J%)
500 NEXTJ%
510 NEXTI%:RETURN
520 '
530 CLS:PRINT"REWIND 'NAMES' TAPE, SET UP FOR 'RECORD' AND HIT
'ENTER'":INPUTAN$
540 CLS:PRINT"RECORDING NAMES"
550 I%=1
560 IF I%>LN$ THEN PRINT#-1,"END":GOTO580
570 PRINT#-1,NAS(I%):I%=I%+1:GOTO560
580 CLS:PRINT"REWIND 'SCORES' TAPE, SET UP FOR 'RECORD' AND HIT
'ENTER'":INPUTAN$:CLS:PRINT"PRINTING SCORES--PLEASE STAND BY"
590 FORI%=1TOLN$
600 FORJ%=1TOL0
610 PRINT#-1,DI%(I%,J%)
620 NEXTJ%
630 NEXTI%:RETURN
640 ' CHANGE DATA FOR ONE ENTRY
650 CLS:INPUT"ENTER GOLFER'S CODE NUMBER":J%
660 IF J%>LN$ OR J%<1 THEN650
670 CLS:I%=J%:GOSUB770:J%=I%
680 PRINT"440,";:INPUT"ENTER NUMBER<1-10> OF DATA TO CHANGE":L%
690 IF L%<1 OR L%>10 THEN680
700 PRINT"576,";:PRINT"ENTER DATA AS <F OR B, SCORE>
FOR EXAMPLE--F,49":INPUTAN$,SC%
710 IF SC%<25 OR SC%>150THEN700
720 IF LEFT$(AN$,1)=""THEN 740
730 IF LEFT$(AN$,1)=""THENSC%=-1*SC%
740 '
750 DI%(J%,L%)=SC%:GOSUB770:PRINT"960,";:INPUT"HIT 'ENTER' TO C
ONTINUE":AS:RETURN
760 ' DISPLAY ONE ENTRY ON SCREEN
770 CLS:PRINT," DATA FOR ";NAS(I%); " FOLLOWS:":
780 PRINT"126," 1 2 3 4 5 6 7 8
9
790 PRINT"192,STRING$(64,"-");
800 FORJ%=1TOL0:IF SGN(DI%(I%,J%))<0THENPRINT"B/"; ELSEPRINT"F/"
;
810 PRINTUSINGI%;ABS(DI%(I%,J%));:PRINT " ";NEXTJ%
820 RETURN
```

```
830 ' ADD NAMES TO LIST
840 LN$=LN$+1
850 CLS:PRINT"ENTER NEW NAME, <LAST NAME.FIRST INITIAL>
FOR EXAMPLE 'JONES.J'":PRINT:PRINT:INPUTNAS(LN%)
860 PRINT"YOU HAVE ENTERED THE NAME ";NAS(LN%), " IS IT RIGHT?
(Y/N)"
870 INPUTAN$:IFLEFT$(AN$,1)=""THENRETURN ELSE850
880 ' UPDATE SCORES
890 CLS
900 FORI%=1TOLN$
910 GOSUB770
920 PRINT"704,";:PRINT"ENTER DATA IN THE FOLLOWING FORMAT: <LE
TTER,SCORE>
LETTER: E-EXIT TO MENU...N-NEXT PLAYER...F-FRONT NINE...
E-BACK NINE..."
930 INPUTAN$,SC%
940 IFLEFT$(AN$,1)=""THENRETURN
950 IFLEFT$(AN$,1)=""THEN950
960 IFLEFT$(AN$,1)=""THENSC%=-1*SC%
970 FORK%=1TOL0:DI%(I%,K%+1)=DI%(I%,K%)+NEXTK%
980 DI%(I%,1)=SC%:GOTO910
990 NEXTI%:RETURN
1000 ' DISPLAY ROUTINE
1010 CLS
1020 PRINT"204,""HANDICAPS FOR ";LN$
1030 PRINT"65,"NAME HANDICAP"
1040 PRINT"129,STRING$(63,"-");
1050 LC%=1:I%=1
1060 PRINT"(193+64*LC%)"";:PRINTUSING% %";NAS(I%);"
";GOSUB110:IPM%<2THENPRINT"LESS THAN 2 ROUNDS" ELSEPRINTWC
1070 LC%=LC%+1:I%=I%+1
1080 IFI%>LN$THENINPUT"HIT 'ENTER' WHEN DONE":ANS:RETURN
1090 IF LC%>10THENINPUT"HIT 'ENTER' FOR NEXT PAGE OF DATA":AN$
;LC%=1:FORJK=193TO1000:PRINT"JK,";:NEXTJK
1100 GOTO1060
1110 REM HANDICAP CALCULATION ROUTINE
1120 FORL%=1TOL0:TM%(L%)=0:NEXTL%: ' FILL TEMPORARY ARRAY
1130 FORL%=1TOL0
1140 GOSUB 1600: ' CHANGE RAW SCORE TO DIFFERENTIAL
1150 NEXTL%
1160 REM
1170 M%=0
1180 FORL%=1TOL0:IFTM%(L%)<0 THEN M%=M%+1:'NONZERO ENTRIES CNT
1190 NEXTL%
1200 REM
N= # OF DIFFERENTIALS TO AVERAGE
1210 IF M%<2 THEN 1280
1220 IF M%=2 THEN M%=1
1230 IF M%=3 OR M%=4 THEN M%=2
1240 IF M%=5 OR M%=6 THENM%=3
1250 IF M%=7 OR M%=8THENM%=4
1260 IF M%=9 OR M%=10 THENM%=5
1270 GOTO 1290
1280 HC=0:RETURN
1290 REM GO TO CALCULATION ROUTINE
1300 GOSUB1360: ' SORT TM()
1310 SM%=0
1320 FOR L%=1TOL0:SM%=SM%+TM%(L%):NEXTL%
1330 SM=(SM%/M%)*10
1340 GOTO1500
1350 RETURN
1360 REM SORT ARRAY IN ASCENDING ORDER
1370 REM M=# OF NON-ZERO ENTRIES
1380 REM SP=SWAP FLAG, 1 IF A SWAP WAS MADE
1390 SP%=0
1400 FORL%=1TOL0-1
1410 IF TM%(L%)>TM%(L%+1) THEN 1460
1420 NEXTL%
1430 IF SP%=1 THEN 1390
1440 RETURN
1450 REM
1460 SP%=1
1470 TX%=TM%(L%):TY%=TM%(L%+1)
1480 TM%(L%)=TY%:TM%(L%+1)=TX%
1490 GOTO 1420
1500 REM HANDICAP LOOKUP ROUTINE
1510 REM HC=HANDICAP
1520 REM SM=SUM OF DIFFERENTIALS
1530 RESTORE:HC=0:IF SM>358.8 THEN NC=35:GOTO1350
1540 READ DL
1550 IF SM<DL THEN 1350
1560 HC=HC+1:GOTO1540
1570 DATA 5.0,17.6,29.4,41.1,52.9,64.7,76.4,88.2,99.9,111.7,123.
5
1580 DATA 135.2,147,158.8,170.5,182.3,194.1,205.8,217.6,229.4,24
1.1
1590 DATA 252.9,264.7,276.4,288.2,299.9,311.7,323.5,335.2,347,35
8.8
1600 SC%=DI%(I%,L%)
1610 IF SC%>0THENRETURN
1620 IPSC%<0THENM%(L%)=ABS(DI%(I%,L%))-B9 ELSE TM%(L%)=DI%(I%,L
%)-F9
1630 RETURN
1640 ' DELETE NAMES
1650 CLS:INPUT"ENTER NAME TO DELETE":AN$:I%=0
1660 I%=I%+1
1670 IF NAS(I%)=AN$THEN1690
1680 IF I%>LN$ THEN1750ELSE1660
1690 FORJ%=I%-1TOLN%:NAS(J%-1)=NAS(J%):NEXTJ%
1700 FORJ%=1TOLN%
1710 FORK%=1TOL0
1720 DI%(J%-1,K%)=DI%(J%,K%)
1730 NEXTK%
1740 NEXTJ%:LN$=LN%-1:RETURN
1750 INPUT"NAME NOT FOUND, DO YOU WANT TO TRY AGAIN? (Y/N)":AN$
IF LEFT$(AN$,1)=""THEN1650ELSERETURN
```



BUSINESS

NOW!

The Ultimate in Mailing Packages **POSTMAN MASS MAILING SYSTEM**

©1982 Alger Software, Distributed exclusively by Soft Sector Marketing, Inc.

For the serious businessman who has as little as 100 name mailing list or 200,000 names, THERE IS ONLY ONE SYSTEM FOR YOU!

FEATURES OF THE NEW POSTMAN MASS MAILING SYSTEM

The Postman system (version 2) is an almost COMPLETE rewrite, rethink, redesign of the original POSTMAN. The many features of the new POSTMAN system are quickly outlined below:

MULTI-DRIVE - True multi-drive operation is possible. POSTMAN will search all drives for address files and connect them together into one large file for the duration of that session. Once POSTMAN has found the data files on the disks, the operator sees just ONE CONTIGUOUS sorted list of addresses. The operator does not need to tell POSTMAN when to "switch" drives or manually "swap" sections of the data file in and out of the computer's memory. This is the foremost among the list of features because of its relative uniqueness among mail list handlers written for the IRS-80.

LARGE LIST SUPPORT - The multi-drive operation allows the user to access data files on ALL configured drives CONCURRENTLY (at the SAME time) for truly large mailing lists. Files need not be sectioned into smaller "byte size" chunks to fit into memory.

HARD DISK SUPPORT - (HARD DISK POSTMAN only) The FULL utilization of the space and speed of the new hard disk drives is possible with POSTMAN. For example, a 7.5 megabyte drive can be configured to hold almost 60,000 labels. Multiple hard drives can be accessed CONCURRENTLY allowing 200,000+ entry mailing lists.

FORM LETTER CAPABILITY - With the purchase of the separate POSTRITE program, the user is provided with an easy to use form letter generator which will merge a generalized letter produced from a word processing system (i.e. LAZY WRITER, etc.), with the name and address information from the POSTMAN MASS MAILER data base. POSTWRITER allows the user to insert any field from a POSTMAN label entry anywhere in the letter.

MENU OPERATION - As you would in a restaurant, choose your dinner from a list (or MENU). POSTMAN will allow you to direct its actions by selecting from various menus that it will display. A complete discussion of each menu is presented in the manual.

INSERT - New names can be quickly added to your list at any time. The new addresses are placed into the file in their proper sorted order eliminating the need for a separate sort operation after entering a stack of new names. POSTMAN will allow the operator to enter a "batch" of labels without returning to the control menu between each label insertion, thus speeding entry and reducing the aggravation of extra menu control keystrokes.

DELETE - Names can be removed at any time when they are no longer needed.

EDIT - Information in any name entry can be quickly changed at will with "word processor" ease. A "transparent" cursor simply is moved to the label displayed on the computer screen and corrections are just typed over the existing label. If you happen to change a field which is also used as a sort key, POSTMAN will automatically move the changed label to its correct position in the list to maintain the sorted arrangement of the labels.

OVERLAY - When identical changes are needed on many addresses, the OVERLAY feature can make them with one keystroke. The needed changes which are common to many labels are entered into the "overlay mask". When you wish to apply these common changes to any label, one command will do it!

SORT - Arrange your list in any alphabetic or numeric order. The ordering may use one or more fields to control the sort. A machine language heap sort assures fast execution. The sort need only be performed once, the sorted list will stay sorted through all subsequent insertions, deletions, and changes to existing labels. NO NEED to leave the POSTMAN program to use a separate program to sort your data. Your data is sorted quickly and after sort completion, POSTMAN is ready for your next command!

SPECIAL STREET ADDRESS SORT - For the user with many addresses on the same street POSTMAN will sort your entries by the house NUMBER after grouping those on the same street together. Local city lists can be quickly sorted to aid post office dispatching.

PURGE - Unwanted duplicate addresses can be removed from your list automatically or under operator control.

SEARCH - Any address in your list can be quickly found with fast search and positioning commands. Three different types of searches are provided: A "last" search which uses a indexing technique, a "selective sequential" search for labels with common fields, and a "quick" positioning using the first or major sort field to get you into the general "ball park" of a label or sequence of labels.

LABEL PRINTING - One, a few or all addresses in your list can be printed on standard or non-standard label stock. Up to 6 labels across can be printed with a format YOU can easily control. TWO user definable "ATTN" lines are provided for any use. Labels can be printed from many of POSTMAN's menus, search, edit, or during label insertion.

EFFICIENCY - POSTMAN is written in the machine's native language to gain the full advantage of the microcomputer's speed. Extensive use of program segmentation reduces the amount of use RAM needed to hold the program, allowing a greater number labels to be kept in core, resulting in faster operation. Little used routines need only be brought into memory when they are needed and once through with their task, release their space back to POSTMAN.

REPORT LISTINGS - A special program to produce columnar listings of address data from your label data base is provided. You can easily specify the information to be printed.

DATA DISK MERGING - Labels can be quickly transferred from one disk to another with the POSTMERGE program callable from the main POSTMAN SYSTEM menu. Source and destination drives needed, not be separate drives, prompts to exchange diskettes if the same drive is used are provided.

DATA DISK PREPARATION UTILITY - Provided with POSTMAN is the DPREP program which allows the user to prepare a floppy/hard disk for use with POSTMAN. This easy to use utility can be told to prepare any portion of the available space on a disk.

DATA INTEGRITY - All data transfers to the disk files are made using special write commands which instructs the operating system to check the validity of EACH write to the disk.

DATA GUARD - is a special programming technique only offered by Soft Sector Marketing, Inc. If by chance your machine resets while writing information to the disk, you only lose the information that you were writing. Your files are always protected from the danger of losing all the work that you have put in that day. NO OTHER PROGRAM ON THE MARKET OFFERS THIS PROTECTION. If you reset with ANYBODY'S MAILING PACKAGE DURING WRITING you would destroy your ENTIRE data disk. We can't stop your machine from failing but we can protect your data.

IDEAL SYSTEM

Mod III 48K 1-40 Track Drive • 2-80 Track Dual Headed Drives • Dosplus or Newdos-80 Operating Systems

Gives space for over 11,000 names - 5 second average name insertion - time sorts all 11,000 names in less than 4 minutes

*Special version to work on Dosplus 4.0 Hard Disk operating system.

- Overview Available -

The POSTMAN system requires Mod I or Mod III, 48K, 2 disk drives minimum.

Standard Version
Only **\$125.00**

Standard Version with
POSTWRITER form letter writer
\$175.00

For DOSPLUS Hard Disk
4.0 Operating System
\$225.00

- DEALER INQUIRIES WELCOME -

88

SSM SOFT SECTOR MARKETING, INCORPORATED

6250 Middlebelt • Garden City, Michigan 48135

Order Line **800-521-6504**

Michigan Orders & Questions 313-425-4020



PAYMENT - payment accepted by check or money order. All checks must be processed when shipped. Payment by check is subject to our standard terms and conditions. **Charges Personal C.O.D.**

SHIPPING & HANDLING - Shipping Charges: Send the larger amount, 7% or 2.50 (whichever is greater) plus shipping. Any order received without shipping and handling will be shipped **freight collect**. **Air Mail Shipping** outside of North America, please send the larger amount, 10% of 7.00 (whichever payment will be refunded).

The Quality Continues.

hole scores. Although the USGA system requires 18-hole scores, most small leagues play 9-hole matches; handicaps based on 9-hole scores are more useful. In addition, the USGA system does not calculate a handicap until a golfer turns in five or more scores. I have observed that many league members play very little golf, but would still

like to have a handicap. My program requires only two 9-hole scores to calculate a handicap. Although not as accurate as the USGA method, I think this is a fair compromise for small leagues. I will discuss methods of estimating handicaps using only one score later.

When you enter players' scores the required format is il-

lustrated in Fig. 2. For any of the entry options, a number is necessary after the comma even if it is meaningless (for example, Exit to menu).

In the usual operating mode the user will sequentially update all players' scores using the (N,x) option to step to the next set of data. You can correct mistakes in the data by selecting menu Option 8. In this mode, the data for one golfer (you must know the player's number) is displayed and you are prompted

for the number of the wrong data. You replace the incorrect data by using the data entry procedure described above.

Once you have updated the data for all golfers, menu Option 7 will display the golfer's name and handicap. This option displays 10 entries on the screen at one time. After the user records the data, pressing Enter will display the next 10 entries. If less than two scores are entered for a golfer, that message will appear in place of the

```

Option—3
ENTER NEW NAME, LAST NAME.FIRST INITIAL
FOR EXAMPLE 'JONES,J'

? AVERY.M_

Options—5,6

          DATA FOR AVERY.M FOLLOWS:

  1   2   3   4   5   6   7   8   9   10
B/ 46 B/ 54 F/ 44 F/ 43 B/ 51 F/ 48 F/ 47 B/ 43 F/ 44 F/ 0

ENTER DATA IN THE FOLLOWING FORMAT: LETTER,SCORE
LETTER: E-EXIT TO MENU...N-NEXT PLAYER...F-FRONT NINE...
          B-BACK NINE...EXAMPLE F,45
? _
  
```

Figure 2

ANS	Temporary answers to prompts
F9,B9	Par for front and back nine
LNS	League name
LN%	Number of golfers
NAS()	Names array
DI%()	Two-dimensional array of scores
SC%	Raw scores
IS	Format string for data display
HC	Calculated handicap
LC%	Line counter for data display
TM%()	Temporary array for storage and sorting
M%	Number of non-zero data entries in array
SM%	Sum of differentials
TX%,TY%	Temporary storage for swapping during sort

Table 1

28 BASIC COMPUTER/CONTROLLER

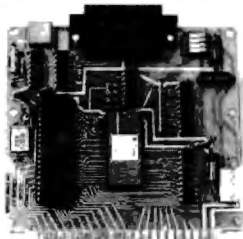

As featured in
Byte Magazine, July and August 1981

- On board tiny BASIC Interpreter.
 - 2 on board parallel ports.
 - Serial I/O port
 - 6 interrupts.
 - Just attach a CRT terminal and immediately write control programs in BASIC.
 - BAUD RATES 110-9600 BPS
 - Data and address buses available for 124K memory and I/O expansion.
 - 4K RAM, 2716 or 2732 EPROM operation.
 - Consumes only 1 1/2 WATTS
- 28 Basic Microcomputer/Controller Assembled & Tested. \$195.00**
Complete Kit \$165.00
Universal Power Supply (+5, +12, & -12v) \$ 35.00
 28 is a trademark of Zilog Inc

SWEET-TALKER, IT GIVES YOUR COMPUTER AN UNLIMITED VOCABULARY.

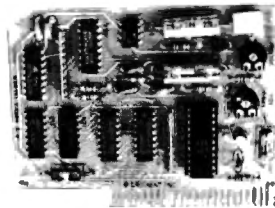

As Featured in
Byte Magazine, September 1981

- Utilizes VOTRAX SC-01A speech synthesizer chip.
 - Unlimited vocabulary.
 - Contains 64 different phonemes which are accessed by an 8-bit code.
 - Text is automatically translated into electrically synthesized speech.
 - Parallel port driven or Plug-in compatible with APPLE II.
 - On board audio amplifier.
 - Sample Program for APPLE II on cassette
- SWEET-TALKER Assembled and Tested Parallel Port Circuit Card. \$139**
APPLE II Plug-in Card \$149

VOTRAX is a trademark of Federal Screw Works

DISK-80 EXPANSION INTERFACE FOR THE TRS-80 MODEL I



As Featured In
Byte Magazine, March 1981

- Disk controller (4 drives)
- Hardware data separator
- Buffered TRS-bus connector
- Real-time clock
- Printer port (optional)

- DISK 80-ASSEMBLED & TESTED with 32K RAM \$329.95**
Centronics Printer Port add \$ 50.00
DISK-80 pc board \$ 48.00
Printer/Power Supply pc board \$ 16.00
Complete Kit with 32K RAM and Printer Port \$275.00

TRS-80 is trademark of Tandy Corp.

To Order: Call Toll Free - 1-800-645-3479
 (In N.Y. State Call: 1-516-374-6793)
 For Information Call: 1-516-374-6793

MICROMINT INC.
 917 Midway
 Woodmere, N.Y. 11598



COLOR COMPUTER

MASTER CONTROL

Copyright ©1981 Soft Sector Marketing, Inc. - Written by A. Schwartz

Requires 16-32K

1. 50 preprogrammed command keys. Standard and Extended command.
2. Direct control of motor, trace, and audio from keyboard.
3. Automatic line numbering.
4. Programmable Custom Key.
5. Direct Run Button.
6. Keyboard overlay for easy program use.
7. Easy entry of entire commands into computer.

Load Master Control into your machine then either type in a BASIC program or load one in from tape to edit. Cuts programming time by 50% or more.



\$24.95

For the Radio Shack
Color Computer*

COLOR BONANZA

Some 4k
Some 16k
Some 32k

Written by E.R.I

**50 PROGRAMS
In One Package**

*The Color Computer is a product of Radio Shack,
division of the Tandy Corporation

Tape 1	Keys	4k	NE	Tape 4	Graphics	16k	EXT
	Bagels	4k	NE		Songs	16k	EXT
	Find	16k	NE		Joy	16k	EXT
	Darts	4k	NE		Mortgage	16k	EXT
	Motor	4k	NE		Checkbook	16k	EXT
	Bomber	4k	NE		Draw 1	16k	EXT
	Football	16k	EXT		Morris	16k	EXT
	Kapow	4k	NE		Sound	16k	EXT
	Dodge	4k	NE	Tape 5			
Tape 2	Bounce	16k	EXT		Ram	16k	MA
	Tank	32k	EXT		Trace	16k	MA
	One Arm	4k	NE		MMaster	16k	MA
	Chute	16k	EXT		Demo	16k	NE
	Where is it	16k	EXT		Disassembler	16k	NE
	Lunar Lander	16k	EXT		Basug	16k	NE
	Stock Market	4k	NE		Ohmiaw	4k	NE
Tape 3					Convert	4k	NE
	Multiply	16k	EXT		Drawer 2	32k	EXT
	Divide	16k	EXT		Degrees	4k	NE
	Add Sub	16k	EXT	Tape 6			
	Simple Simon	4k	NE		Hurdler	32k	EXT
	Hangman	16k	NE		Entrap	16k	EXT
	Beast	16k	NE		Search	16k	NE
	Count Down	4k	NE		Flip Flop*	16k	EXT
	Acey	16k	NE		Last Atom	16k	EXT
	Gene	16k	NE		Attack	16k	EXT
	Protect	16k	EXT		Cartel*	32k	EXT

MA = Machine language
NE = Non Extended Basic
EXT = Extended Basic

List **\$49.95**
6 Cassettes - Disk version available
soon.

85

- DEALER INQUIRIES WELCOME -

SSM SOFT SECTOR MARKETING, INCORPORATED

6250 Middlebelt • Garden City, Michigan 48135
Order Line **800-521-6504**
Michigan Orders & Questions 313-425-4020



PAYMENT—payment accepted by charge, personal check, or C.O.D. only under the following conditions: **Charges** processed when shipped; usually within 48 hours. **Personal C.O.D.** **Checks** delay shipping; pending 3 weeks to clear.

orders are certified check or cash only; add \$1.50. MI residents must add 4% sales tax. **SHIPPING & HANDLING** - Shipping Charges: Send the larger amount, 2% of \$100.00 unless stipulated otherwise. Any order received without shipping and handling will be shipped **freight collect**. **Air Mail Shipping** outside of North America, please send the larger amount, 12% of \$100.00. Overpayment will be refunded.

The Quality Continues .

handicap, and you will have to estimate the golfer's handicap. The golfer might estimate his score before the round, subtract par from the estimate and multiply the difference by .8. The result will be a handicap that he can use for that round. After the round, if the actual score was off from the estimate by more than two strokes, recalculate the handicap using the actual score.

When the user finishes with the program, he saves the data on cassettes using Option 1. A normal data cassette is sufficient for the names tape; a minimum of a C-90 is required for the scores. Although the computer memory limitations allow about 100 names and data, the cassette storage for this much data would be excessive. I felt that 40 golfers was a good compromise. If your league has more than 40 members, you can run the program twice.

Final Thoughts

When I designed the program,

I made several trade-offs to minimize memory and cassette usage. I used integer variables extensively for this reason. You cannot use different course scores as the data would be single precision in that case, and use more cassette storage.

With disk data storage, you can store scores from many courses. I use a 48K disk system for my own handicap calculations, and store differentials instead of raw scores. With a cassette-based system, however, these limits are necessary.

My experiences with league

handicaps led me to choose 10 scores for storage rather than 20 as is used in the USGA system. Many golfers in leagues would not have the necessary five scores under the USGA system until the season was half over. Using this modified program, only two scores are necessary to establish a handicap.

Table 1 lists the variables I used in the program. I set up the program in separate modules. Table 2 lists these modules. Most of the program is straightforward. Course data is stored as (plus/minus) raw score; a

minus score indicates a back nine entry. The scores data is stored in a two-dimensional array.

The handicap calculation routine first fills a temporary one-dimensional array with the non-zero entries of the golfer's data minus the course par. The array is then sorted with the smallest entry first. The average of the low half of the non-zero entries is found and multiplied by 10. This value is then compared to a standard list to determine the handicap.

This program will do a credible job for a small golf league. Unfortunately, the shortcomings of the cassette storage system become very visible if you use the program with a large league. In this case, a disk-based system is almost a necessity. ■

Michael Avery is an Analytical Engineer for the U.S. Department of Energy at Ames Laboratory at Iowa State. He is also a ham radio operator.

Numbers	Description
70-130	Program instructions
190	Program menu
390	Cassette input/output
650	Correct data for one golfer
770	Display data for one golfer
840	Add names to NA\$()
890	Update data for all golfers
1010	Calculate and display handicaps
1110	Handicap calculation
1610	Calculate differential from raw score
1650	Delete name and data from list

Table 2

DISCOUNT HARDWARE

**6.3 MEGABYTE
WINCHESTER FOR MOD III \$1895**

(Includes P.S., Enclosure, Adaptor, & Cables)

DOS PLUS 4.0 for above \$299

PRINTERS

MX-80 w/graphtrax \$449

MX-80 FT \$529

MX-100 \$679



1051 Elden St. ■ Herndon, VA 22070 (703) 471-5910



- * SUPPORTS ALL MX-80 PRINT STYLES
- * WORDPROCESSING TEXT CONTROL MODE
- * MENU MODE FOR GENERAL APPLICATION
- * TRUE PROPORTIONAL JUSTIFICATION

- * UNDERLINES ANYWHERE
- * SUPERSCRIPTS
- * DYNAMIC CONTROL OF LINE SPACING IN 1/72 IN. INCREMENTS
- * DYNAMIC CONTROL OF MARGINS
- * WORKS WITH MOST PROGRAMS INCLUDING SCRIPBIT™

Maxprint is an extraordinary user oriented printer driver utility program which allows you to select any MX-80 print style or function such as underlining on a character by character basis within word processing text. Maxprint also features proportional right margin justification within a block of standard text to give your printout a truly professional appearance.

Maxprint consists entirely of Z-80 machine language for fastest possible printing performance. Minimum system requirements are a 32K Model I or Model III with one disk drive.

Unleash the true potential of your MX-80. Maxprint is supplied on disk with an extensive 40 page manual and shipping for only:

*** * * 27.95 * ***

TO ORDER: Call (408) 737-2253 Visa / Mastercard
Send check or money order to
Peggytronics,
381 First Street, Suite 3147
Los Altos, California 94022

✓ 333

CA residents add 6% sales tax // Scripbit™ of Tandy Corp.



HARDWARE SPECIALS

LYNX MODEM

Auto Answer - Auto Dial

Mod I & III
No RS-232
Board Required

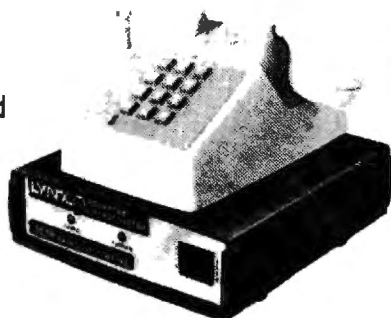

Shipping from Stock
\$218.00
Plus Shipping

DISKETTES

40 Track, Double Density,
Single Sided

\$23.95
Plus Shipping

40 TRACK TANDON DISK DRIVE

with Power Supply & Case

\$260.00
Mod I or III - Please State
Add \$5.00 per drive shipping.

RIBBONS

Okidata 82A
& 83A Ribbons **\$4.50** ea.
12 at a time **\$4.00** ea.

R.S. Daisy Wheel II
Multistrike **\$6.25** ea.
12 at a time **\$5.25** ea.

SPECIAL This Month Only C-ITOH, 40 CPS DAISY WHEEL PRINTER **\$1495.00**

Any prepaid orders on this printer - we pay shipping. Good only month of magazine.

OKIDATA 82A



\$499.00

Performance

Print speed: cps - 120
Print technique - Bidirectional
Short line seeking - Standard
Columns: Standard Characters - 80
Condensed characters - 132

Printing Characteristics

Matrix, standard characters - 9 x 9
Character set - Full 96 character ASCII
plus 64 block graphics shapes

Ribbon

Media - Standard four mil 1/4" wide on 2" spools

Interface

Parallel Centronics - compatible - Standard
Serial RS232C, 1200 bps - Standard

Reliability

MTBF - 4000 hours

Warranty

Ninety days parts and labor, one year on print head under normal use

Add \$7.50 Shipping.

NEW OKIGRAPH I

Dot Addressable Graphics for 82A
\$99.95

- DEALER INQUIRIES WELCOME -

SSM SOFT SECTOR MARKETING, INCORPORATED

6250 Middlebelt • Garden City, Michigan 48135
Order Line **800-521-6504**
Michigan Orders & Questions 313-425-4020



PAYMENT - payment accepted by charge, personal check, or C.O.D. only under the following conditions: **Charges** processed when shipped, usually within 48 hours. **Personal Checks** delay shipping, pending 3 weeks to clear. **C.O.D.** collect. **Air Mail Shipping** outside of North America, please send the larger amount, 10% of \$10.00. Overpayment will be refunded.

orders are certified check or cash only, add \$1.50. MI residents must add 4% sales tax. **SHIPPING & HANDLING - Shipping Charges:** Send the larger amount, 2% of \$2.50 unless stipulated otherwise. Any order received without shipping and handling will be shipped **freight collect**. **Air Mail Shipping** outside of North America, please send the larger amount, 10% of \$10.00. Overpayment will be refunded.

The Quality Continues

Cryptology in Tiny Pascal.

Kryha Cipher Machine

C. A. Deavours
Kean College of New Jersey
Union, NJ 07083

I use my TRS-80 for cryptological pursuits so I programmed an emulation of a mechanical cipher machine from the 1920s using tiny Pascal. I chose a device patented by a German engineer, Alexander von Kryha.

The cryptographic principle used by the Kryha machine is simple to employ on a computer.

Aside from a natural program structuring, I could use modular arithmetic and recursion (the ability of a function or subroutine to call itself) to exploit some of Pascal's features. The only minor problems were the lack of explicit character handling instructions and storage space.

Cryptographic Principles

Cryptology is the science of secret writing. This includes devising methods of enciphering or encoding and deciphering or decoding messages (cryptography), and methods of cracking coded messages (cryptanalysis).

A fundamental form of cryptographic writing is simple or monoalphabetic substitution. Simple substitution is accomplished by replacing every letter of the message (called plaintext) by another letter to produce the coded message (called the ciphertext or cryptogram). For example, consider the plaintext message Attack At Dawn. To encipher this message we might set up two alphabets as shown in Table 1.

To produce the cryptogram, replace each letter of the message as it is found in the top alphabet by the letter below it in the bot-

tom alphabet (see Table 2).

The cryptogram is usually divided into five-letter groups to destroy the word divisions and thus make it harder for an unauthorized person to guess the text. In this case, we transmit the cryptogram ZGGZX PZGWZ DM.

The Key Box

Model I
48 K RAM
TRSDOS 2.3
2 Disk Drives
Line Printer II



Photo 1. Kryha Mechanical Cipher Machine



Photo 2. Outer alphabet ring detached. Note removable letter blank

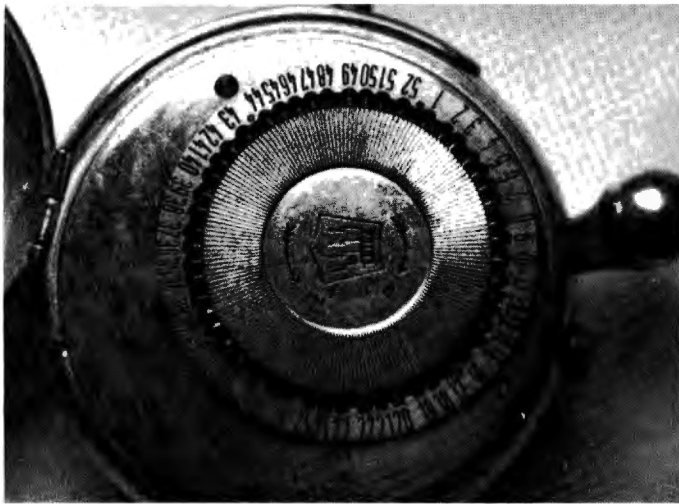

Photo 3. Drive wheel showing extended pins

The telegraph company will count each five letter group as one word if you send telegrams or mailgrams in cipher.

The message is harder to solve if the two alphabets are mixed instead of being in a standard forward or backward sequence. If the second alphabet is the same as the first one reversed the encipherment is reciprocal; you can encipher and decipher using either alphabet as the plain or cipher alphabet and find the corresponding letter in the other. For instance, F has U below it in our example but F in the second alphabet also has U above it. This principle holds even if the two alphabets have mixed letters, as long as the sequence runs in opposite directions.

As the accompanying photos show, Kryha's cipher machine held two alphabets on concentric disks. The letters of both alphabets could be removed and replaced in any mixed order desired. My program, for simplicity, assumes the outer alphabet to bear the normal A-Z sequence and the inner one to bear the reversed sequence Z-A.

If the two alphabets retain their positions relative to one another, a simple substitution is generated by replacing each plaintext letter of the message on one disk with the adjacent letter in the other disk ring. The Kryha machine achieves complexity by requiring the user to press the lever after each letter is enciphered. This action rotates

the inner ring a certain number of steps with respect to the outer one. For example, if the inner ring rotated three positions counterclockwise a new simple substitution is generated. The previous alignment, with Z below A would be changed to the alignment shown in Table 3.

At the new position the letter A becomes W in the ciphertext. By altering the relative position of the two alphabets with each letter enciphered one can generate up to 26 different simple substitutions (since there are 26 alignments of the two alphabets). The Kryha machine attempts to produce these substitutions in an irregular manner.

The movement of the rings is determined by a drive wheel divided into a number of sectors. Each sector possesses a variable number of teeth determined by extending or retracting pins in that sector (see photos). Each time the encipherer pushes the lever (normally, after each letter is enciphered) the drive wheel advances one sector. This in turn drives the inner ring as many places forward as there are teeth in that sector. Suppose a drive wheel has five sectors with teeth 1,3,2,1,0 respectively. Further let the first sector be the current one and the two alphabets fixed so that B lies below A on the alphabet rings. If we encipher the message AAAAA AAAAA, the corresponding cipher text generated is BYWV URPOO NKIHH. How

Plaintext alphabet: A B C D E F G H I J K L M N O P Q R S T U V W X Y Z
Ciphertext alphabet: Z Y X W V U T S R Q P O N M L K J I H G F E D C B A

Table 1. Reciprocal Enciphering

Plaintext: ATTACK AT DAWN
Cryptogram: ZGGZXP ZG WZDM

Table 2. Encrypted Message

Plaintext alphabet: A B C D E F G H I J K L M N O P Q R S T U V W X Y Z
Ciphertext alphabet: W V U T S R Q P O N M L K J I H G F E D C B A Z Y X

Table 3. Altered Reciprocal Relationship

does this come about?

The first ciphertext letter (B) results since the two rings were initially set so that A had B under it. To encipher the next letter A, the drive wheel advances one sector. The next sector with three teeth rotates the inner ring three steps counterclockwise. Now the letter A on the outer ring has Y under it. The next sector has two teeth,

placing the letter W under A, and so on.

The stepping sequence 3,2,1,0,1,3,2,1,0,1,... keeps repeating, but the alphabetic alignments do not repeat as often. This is because the sum of the pins (1+3+2+1+0) equals 7. After one revolution of the drive wheel (five letters enciphered), the inner ring has



SCOTT ADAMS' ADVENTURES

NOW FOR **NEW**

CP/M (Z-80) & Model II TRSDOS

The bestselling Adventure series by Scott Adams is now available for CP/M (Z-80) and Model II TRSDOS users! This is the original Adventure series which has received rave reviews in every major computer magazine. Order now!
8" Disk of ALL 12 Adventures \$129.95













Minimum 24K • Single density • Soft sector • Single side
Converted to run under CP/M by Russ Wetmore

A Division of Scott Adams, Inc.
Adventure International • Box 3435 • Longwood, FL 32750
TOLL-FREE ORDER NUMBER: (800) 327-7172
IN FLORIDA (205) 952-9017

Shipping and handling charges are extra. Prices are subject to change without notice.

✓ 20

Please Specify CP/M or TRSDOS

Dealer Inquiries Invited

Program Listing

```

.C
(*****KRYHA CIPHER MACHINE EMULATION*****)
(=C. DEAVOURS, MATH. DEPT, KEAN COLLEGE OF N.J., UNION, N.J., 12/15/80=)
CONST START=15488;C=26;
VAR CHAR, LAST, STOP, N, I, SUM, PERIOD, Z, POS, C1, C2, H, SAVE: INTEGER;
TEETH: ARRAY(21) OF INTEGER;
FUNC GCD(A, B);
BEGIN
  IF B=0 THEN GCD:=A ELSE GCD:=GCD(B, A MOD B);
END;
PROC LOOP (=DELAY LOOP=);
BEGIN
  REPEAT Z:=INKEY UNTIL Z='0';
END;
PROC CRYPT (=ENCIPHER/DECIPHER ROUTINE=);
BEGIN
  C1:=0;C2:=0;
  SAVE:=POS;POS:=POS-1;
  STOP:=START;I:=Z;
  REPEAT
    CHAR:=MEM(STOP);STOP:=STOP+1;
    IF (CHAR>64) AND (CHAR<91) THEN
      BEGIN
        POS:=POS+1;
        CHAR:=(CHAR-45+SUM) MOD C;CHAR:=25-CHAR+45;
        MEM(POS):=CHAR;C1:=(C1+1) MOD 5;
        IF C1=0 THEN
          BEGIN
            POS:=POS+1;C2:=(C2+1) MOD 10;IF C2=0 THEN POS:=POS+4
          END;
        I:=(I+1) MOD N;SUM:=(SUM+TEETH(I)) MOD C;
      END;
  UNTIL STOP=LAST;
END;
PROC KEY1 (=ENTER NUMBER OF SECTORS AND TEETH PER SECTOR, CALCULATE PERIOD=);
BEGIN
  SUM:=0;WRITE(28,31,'          KRYHA CIPHER MACHINE EMULATION',13,13);
  WRITE('ENTER NUMBER OF SECTORS ( <22 ):');
  READ(N#);I:=0;
  REPEAT
    WRITE(13,'# TEETH IN SECTOR ',I#,' = ');READ(Z#);
  
```

Program continues

turned only seven of its 26 steps. After two drive wheel revolutions, the inner wheel has advanced only 14 steps. In fact, since 26 and 7 have no common divisors, the alphabetic shift sequence does not repeat until 26 times 7, or 182 letters have been enciphered. The length at which the sequence repeats is called the period of the cipher. A longer period means the cryptogram will be more difficult to solve. If we call the first alphabet zero, the next one shifted three steps from it alphabet three, and so on, the entire 182 letter shift period is shown in the array of Fig. 1. Each row represents one revolution of the drive wheel.

If the drive wheel contains N sectors, the longest period which can be obtained is 26 times N letters. This period occurs when the greatest common divisor of the sum of the teeth and the number 26 is one. In general, the period is given by $Period = (N * Sum) / GCD(26, N)$ where Sum is the total number of teeth in all sectors of the drive wheel and GCD is the greatest common



TRS-80™

DISCOUNT

TRS-80 MODEL II
64-K **\$3350**
8 4 MEGABYTE HARD DISKS
(PRIMARY UNIT) ... \$4040.

TRS-80 MODEL III
48-K **\$2100** 16-K **\$850**
2 DISK RS-232 (ALL RADIO SHACK EQUIPMENT)

FREE
OUT-OF-STATE TAXES AND SHIPPING COSTS
WARRANTIES HONORED BY ALL COMPANY OWNED
RADIO SHACK STORES OR COMPUTER CENTERS
WE ALSO CARRY A FULL LINE OF PRINTERS,
COMPUTORS AND ACCESSORIES

TRS-80 COLOR 4-K \$315
16-K **\$495** 32-K **\$595**
COLOR DISK DRIVES
0-**\$509** 1-2-3-**\$339**
— T. M. TANDY CORP

WE ACCEPT ✓ 124
CERTIFIED CHECKS,
CASHIERS CHECKS
AND MONEY ORDERS

PERRY OIL & GAS INCORPORATED
137 NORTH MAIN ST., PERRY, MICHIGAN 48872 PHONE (517) 625-4161, MICH.
WE OWN AND OPERATE A RADIO SHACK — DEALERSHIP R162

FOR OUR PRICES, PLEASE CALL TOLL FREE **1-800-248-3823**

FOR FAST RELIEF

Take DOSPLUS 3.4

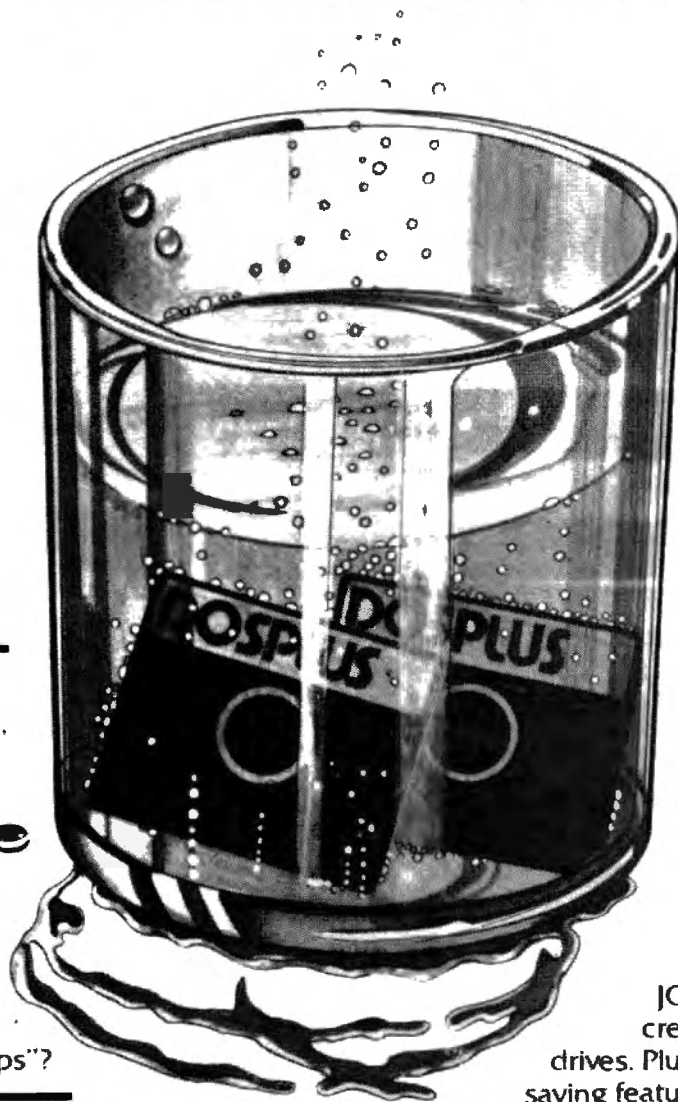

Do you have that tired dragged out feeling known as "DOS Drag" from an operating system that is just **too** slow? Do you have "Computis Interruptous" because you spend more time with your DOS manual than you do at your computer? Has an undependable DOS got you down with the inadvertent "Dumps"?

Then you need DOSPLUS 3.4. DOSPLUS 3.4 contains all the active ingredients for a quick recovery. Dependable fast action features like instant boot-up, BASIC array sort (multi-key, multi-array), Tape/Disk-Disk/Tape utility (with program relocater), Input@ (controlled screen input from BASIC), and complete disk editing features including random access file editing and ASCII modification on sector dump utility.

And who wouldn't feel better with proven features like the ability to use a "DO" (command chaining) file from within a BASIC program, and more reliable BACKUP and FORMAT utilities.

In addition, you have the convenience of repeating the last DOS command with "/" <ENTER>, a single file convert from Model III TRSDOS, file directory supported for Model III TRSDOS disks, complete device routing supported with FORCE and JOIN, and the ability to read or create 40 track disks in 80 track drives. Plus many other time and effort saving features.

Of course, in order for a prescription to work, you've got to follow instructions — in this case the instructions are contained in the new easy to use easy to follow 240 page DOSPLUS users guide with system technical reference section. So, if you're experiencing any DOS related discomfort, get instant relief. **\$149⁹⁵** Get DOSPLUS 3.4

DOSPLUS

First in the Industry backed by a lifetime warranty.



**MICRO SYSTEMS
SOFTWARE, INC.**

5846 Funston Street • Hollywood, FL 33023

(Outside of Fla.)
CALL TOLL FREE
1-800-327-8724

FOR VISA/MASTERCARD/C.O.D. ORDERS
TOLL FREE LINES WILL ACCEPT ORDERS ONLY!
For Applications and Technical information
call (305) 983-3390 or drop us a card
Dealers inquiries invited

✓ 384

Program continued

```

    TEETH(I):=Z;SUM:=SUM+Z;I:=I+1;
  UNTIL I=N;
  WRITE(28,31,'NUMBER OF SECTORS= ',N0,13,'NUMBER OF TEETH = ',SUM0,13);
  Z:=GCD(SUM,26);WRITE('GCD= ',Z0,13);PERIOD:=(N*Z6) DIV Z;
  WRITE('PERIOD=',PERIOD0,13,13,'PRESS ANY KEY TO CONTINUE');READ(I0);
END;
PROC INPUT (*READ IN PLAIN/CIPHER DATA*);
BEGIN
  WRITE(28,31,'ENTER TEXT (LAST CHARACTER=6): ',13,13);
  REPEAT
    CHAR:=INKEY;
    IF (CHAR>64) AND (CHAR<91) THEN
      BEGIN
        MEM(LAST):=CHAR;LAST:=LAST+1;
      END;
    IF CHAR=32 THEN
      BEGIN
        MEM(LAST):=32;LAST:=LAST+1;
      END;
    IF CHAR='@' THEN
      BEGIN
        LAST:=LAST-1;MEM(LAST):=32;
      END;
    IF CHAR='0' THEN STOP:=1;
  UNTIL STOP=1;
  POS:=(LAST-START) DIV 64;POS:=15488+(POS+1)*64;
END;
PROC KEYZ (*ENTER STARTING DISK POSITION AND INITIAL SECTOR*);
BEGIN
  WRITE(28,31,'ENTER STARTING POSITION OF INNER DISK (A-Z): ');READ(Z);
  SUM:=25-Z+65;
  WRITE(13,'ENTER INITIAL SECTOR (1-'N0,')');READ(Z0);
  WRITE(13,'HARDCOPY OF DATA? (Y OR N): ');READ(H);
END;
PROC HARDCOPY (*PRINTER LISTING OF DATA*);
BEGIN
  STOP:=0;
  C1:=MEM(16414);C2:=MEM(16415);
  MEM(16414):=MEM(16422);MEM(16415):=MEM(16423);
  WRITE(13);
  REPEAT
    Z:=MEM(SAVE);WRITE(Z);SAVE:=SAVE+1;
    STOP:=(STOP+1) MOD 64;
    IF STOP=0 THEN WRITE(13);
  UNTIL SAVE=POS+1;
  WRITE(13);
  MEM(16414):=C1;MEM(16415):=C2;
END;

(*MAIN PROGRAM*)
BEGIN
  LAST:=15488;STOP:=0;
  KEY1;
  KEY2;
  INPUT;
  CRYPT;
  IF H='Y' THEN HARDCOPY;
  LOOP;
END.
1193 CODES. 5354-57FC

```

0	3	5	6	6
7	10	12	13	13
14	17	19	20	20
21	24	0	1	1
2	5	7	8	8
9	12	14	15	15
16	19	21	22	22
23	0	2	3	3
4	7	9	10	10
11	14	16	17	17
18	21	23	24	24
25	2	4	5	5
6	9	11	12	12
13	16	18	19	19
20	23	25	0	0
1	4	8	7	7
6	11	13	14	14
15	18	20	21	21
22	25	1	2	2
3	6	8	9	9
10	13	15	16	16
17	20	22	23	23
24	1	3	4	4
5	8	10	11	11
12	15	17	18	18
19	22	24	25	25

Fig. 1. 182 letter period

divisor. This formula assumes that the sector wheel itself is not periodic. With eight sectors and teeth settings 1,2,3,4,1,2,3,4 we might as well use a four sector wheel with settings 1,2,3,4.

Program Description

The program listing shows an emulation of the Kryha machine in Tiny Pascal. The main program calls six procedures:

- **Key1:** The user enters the number of sectors and teeth per sector. You can use up to 21 sectors, but this is easily changed by altering the dimension of the array Teeth. The program then calculates the period generated by these settings. The recursive

function GCD calculates the greatest common divisor of Sum and 26. If GCD equals one, the period is maximal.

- **Key2:** This procedure requires initialization data. These are a letter indicating the beginning placement of the two alphabets (D means begin with D on the inner ring opposite A on the outer, and so on) and a sector number indicating the current sector at startup. The user also indicates if he desires a printout of the ciphertext.

- **Input:** The message (plaintext or ciphertext) is entered here. All characters other than A-Z, @, and blank are ignored. The symbol @ is used for back-

space. Input must be terminated with a \$.

- **Crypt:** This is the encryption/decryption routine. Because of the reversed alphabetic setup, the same routine performs encryption and decryption.

- **Hardcopy:** Delivers copy of ciphertext to the printer by substituting the printer driver address for the video driver address.

- **Loop:** Retains the screen display at the finish of program until you press \$.

To use the program for communication both correspondents must know the key data used in Key1 and Key2. The same key data is entered in both

cases. Ciphertext is in traditional five letter groups. Starting with the same key settings, typing the ciphertext produces the original plaintext without original word divisions.

No storage space is required for the message: It is read directly off the screen. The ciphertext appears directly below it. This means messages are limited to about five lines (320 characters), adequate for short messages. The program occupies about 2500 bytes of source code. Characters are enciphered, deciphered and printed at approximately 59 per second.

How secure are the cryptograms produced? Well, while your friends probably cannot solve them, a knowledgeable cryptanalyst could do so with minimum difficulty. The cryptograms are more difficult if you use mixed alphabetic sequences, but statistical procedures give good results if three or more periods of ciphertext are intercepted. ■

The author is indebted to Louis Kruh, President of the New York Cipher Society for permission to use the photos in this article.

C.A. Deavours is an editor of Cryptologia magazine and an associate professor of mathematics

TRS-80™ DISCOUNT - BUY DIRECT

WE SELL THE FULL LINE OF TRS-80 AT WHOLESALE PRICES

MODEL II

26-4002 64K 1 Drive..... \$3279
Ask About Hard Drives

MODEL 16

26-6001-128K 1 Drive..... \$4158
26-6002 128K 2 Drives..... \$4828

MODEL III

26-1062 16K..... \$819
26-1066 48K with
2 Drives, RS232..... \$2049

COLOR COMPUTER

26-3001 4K..... \$309
26-3002 16K Ext. Basic..... \$453
26-3003 32K Ext. Basic..... \$569

TRS-80 COLOR COMPUTERS *DISK DRIVES*

26-3022 Disk Drive #1..... \$498
26-3023 Disk Drive #2, 3, 4..... \$338

PRINTERS

26-1158 Daisy Wheel II..... \$1648
25-1165 Line Printer V..... \$1358
26-1166 Line Printer VI..... \$988
26-1168 Line Printer VIII..... \$698
26-1167 Line Printer VII..... \$338
Centronics 739-1..... \$499

PERSONAL COMPUTERS

PURE RADIO SHACK EQUIPMENT

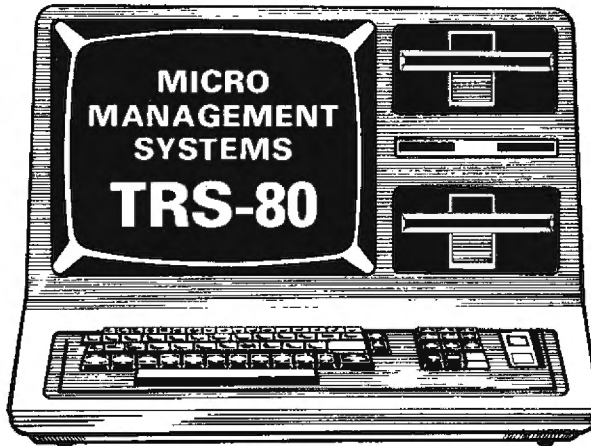

THOUSANDS OF
SATISFIED
CUSTOMERS
DISCOUNT
SOFTWARE

WRITE FOR YOUR
FREE CATALOG

ORDER TOLL FREE
1-800-841-0860

•LARGE INVENTORY
•FAST DELIVERY

TM - TANDY CORPORATION
FREE COPY OF WARRANTY UPON REQUEST

MICRO MANAGEMENT SYSTEMS, INC.

PARCEL DIVISON
DEPT. NO. 4
115 C. SECOND AVE. S.W.
CAIRO, GA. 31728
GA. 912-377-7120

LEARN TO
"DO IT YOURSELF"
AND SAVE

TRS-80™

PERSONAL COMPUTERS

PERSONAL COMPUTERS

MODEL III SOFTWARE

26-1563 Scripsit I & III..... \$79.00
26-1566 Visicalc I..... \$83.00
26-1584 Check-Writer 80..... \$90.00
26-1552 General Ledger..... \$90.00
26-1553 Inventory Ctl..... \$90.00
26-1556 Payroll..... \$180.00
26-1555 Accts. Receivable.. \$135.00
26-1554 Accts. Payable..... \$135.00
26-1558 Bus. Mail List..... \$90.00
26-2201 Fortran III..... \$90.00
26-1562 Profile..... \$72.00
26-1592 Profile III Plus..... \$180.00
26-1565 Microfiles..... \$90.00
26-1569 Visicalc III..... \$180.00
26-1590 Super Scripsit..... \$180.00
26-1591 Scripsit Dictionary.. \$135.00
26-1582 Time Manager..... \$90.00
26-1580 Project Manager..... \$90.00
26-1581 Personnel Manager.. \$90.00
26-1568 Medical Off. Syst... \$270.00
26-2203 Cobol..... \$180.00

COLOR COMPUTER SOFTWARE



MODEL III



MODEL II



COLOR COMPUTER

MODEL II SOFTWARE

26-4515 Profile Plus..... \$270.00
26-4511 Visicalc II..... \$265.00
26-4512 Profile II..... \$162.00
26-4501 General Ledger..... \$180.00
26-4502 Inventory Mgmt... \$180.00
26-4503 Payroll..... \$360.00
26-4504 Accts. Receivable.. \$270.00
26-4505 Accts. Payable..... \$270.00
26-4507 Mail List II..... \$108.00
26-4701 Fortran..... \$270.00
26-4703 Cobol..... \$270.00
26-4705 Compiler BASIC... \$180.00
26-4540 Statistical Analysis . \$90.00
26-4508 Medical Off. System \$675.00
26-4509 Manuf. Inventory... \$675.00
26-4513 Job Costing..... \$135.00
26-4520 Time Accounting... \$450.00
26-4621 Personnel Search... \$270.00
26-4560 Westlav..... \$225.00
26-4531 Scripsit 2.0..... \$360.00
26-4534 Scripsit Dictionary.. \$180.00

POCKET COMPUTER SOFTWARE



96

**CALL TOLL FREE
800 424-2738**



PENETRATOR



By Philip Mitchell from Beam
Armed with missiles and bombs, you must fly your fighter to the enemy's cache of neutron bombs and destroy them. Your mission is in four stages. Involving rugged terrain, caverns and manmade obstacles -- not to mention enemy radar, missiles and paratroopers. This new departure in arcade gaming allows you to set up your own terrain and enemy emplacements, then save them for future use. Make your mission as hard or easy as you like!

Tape or disk...\$24.95



LASER DEFENSE

By Simon Smith from Med Systems
As ground controller for our Laser Satellite Defense System, you can view Eastern Europe or North America. Your job is to knock out enemy missile silos, or falling that, to zap the missiles themselves before they destroy our cities. You must be fast because the enemy is developing an anti-satellite laser of their own!

16K tape...\$14.95 16K disk...\$17.95



ARMORED PATROL

By Westmoreland & Gilman from Adventure
As commander of a lumbering T-36 tank you have the firepower to destroy the enemy -- if you can find them. They may be hiding behind the houses scattered about the bleak terrain and your only view is thru the drivers port (your screen). Impressive animation in this arcade game.

16K tape...\$19.95 32K disk...\$24.95

MYSTERIOUS ADVENTURE I

ARROW OF DEATH - part 1

By Brian Howarth from Acorn
In the first of a series of adventures by this English author, an engulfing sense of bitterness and ill feeling spreads across the kingdom. It becomes so menacing that the ruler is forced to flee the palace in fear. It is up to you and sorcerer Zarda to solve the puzzle and restore the kingdom to normalcy.

16K tape or disk...\$19.95

Visit our other stores: Seven Corners Center · Falls Church, VA & W. Bell Plaza · 6600 Security Blvd. · Baltimore, MD

the PROGRAM STORE



STELLAR ESCORT

By Jeff Zinn from Big Five
This new arcade game from Big Five continues their tradition of bringing you the most exciting action in innovative space games. Your fighting spacecraft must run the gauntlet of the attacking alien's weaponry in order to accomplish your defense mission. You'll use all your skill and dexterity just to survive!

16K tape...\$15.95 32K disk...\$19.95

NEW TRISSTICK JOYSTICK FROM BIG FIVE!
Can be used for all Big Five games plus programs you write. Utilizes the Atari joystick with special interface. Plugs right in!

Specify model I or III...\$39.95



DEFENSE COMMAND

By Hogue & Konyu from Big Five
You are the lone defender of 10 Krotnium fuel cells essential for the survival of the planet. Aliens swoop down from above to steal the fuel; it's your job to destroy them. You can still save the cells after a raid, but you must shoot the alien and simultaneously move under the cell to catch it. If things look bad you can set off one of your 4 antimatter bombs and destroy all enemies on the screen! Arcade fun with action and sound.

16K tape...\$15.95 32K disk...\$19.95



By Cleo Hughes from Liberty
The BRIGHT & EARLY series makes learning fun by rewarding accomplishment with video entertainment. Designed for ages six and older, the math skills package contains: "Add-a-pet" (Addition), "TheBigBoom" (Subtraction), "SpacemanMath" (Multiplication), "MoonLander" (Division), and "Basic Math" (Flash card review).

16K tape...\$13.95



FORTRESS

By Larry Ashmun from Soft Sector
You are in charge of a massive fortress. Your number one priority is its defense against alien attackers. With your protection and firepower, fending off the first attackers is like swatting flies -- but just wait!!

tape...\$15.95 disk...\$19.95

Instant Search/Sort DATABASE

By G. Hatton from Acorn
An easy-to-use, yet powerful database management tool, ISS alleviates many of the complications usually found in setting up and maintaining information files. Written in machine language, ISS can provide a multitude of sorts, subsorts, searches and categorizations in seconds. Because the processing is done in memory, you can manipulate the data at will without risk to your database on tape or disk. The number of records is limited only by your file format and the amount of RAM in your system.

16K tape or 32K disk...\$49.95



BASIC FASTER & BETTER

By Lewis Rosenfelder from ILG
One of the most useful books ever published for TRS-80 owners. Contains a wealth of information on how to optimize your programs with special techniques. Includes libraries of functions and subroutines that can eliminate most of the drudgery of writing programs -- you can write complete programs as a series of subroutine calls! With the optional library and demonstration disks, you'll have all these tools at hand without having to type them from the text.

Book, 290 pages...\$29.95

Library Disk...\$19.95 Demo Disk...\$19.95



TO ORDER CALL TOLL FREE 800 424-2738

For information
Call (202) 363-9797

THE PROGRAM STORE

4200 Wisconsin Avenue NW, Dept. 8E205 Box 9609
Washington, D.C. 20016

MAIL ORDERS: Send check or M.O. for total purchase price, plus \$7.00 postage & handling. DC, MD & VA: add sales tax. Charge cards: include all embossed information on the card.

Get the most from your micro with software and accessories from one of the world's largest selections.

The Program Store

CALL TOLL FREE
800 424-2738

DEATH-MAZE 5000



From Med Systems
Venture through a graphically represented 3-D maze, with halls that could dead end -- or recede to infinity. Step through the doors or drop into the pits. Will you encounter monsters and mayhem, or will you be treated to useful objects and information? Will you ever get out alive?

16K tape...\$14.95 32K disk...\$19.95



-80 SPACE RAIDERS

From Bosen Electronics
You are in command of the Starship "Defiant." The center of the screen is your window to the vastness of three dimensional space. Your orders are simple enough: Patrol the area and destroy all enemy spacecraft; return to base as needed for repairs and supplies. Carrying out these orders is more difficult! An exciting and fast-paced game, it presents an animated pilot's-eye view.

16K tape...\$24.95

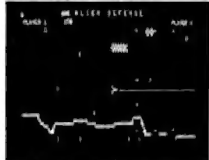

ALIEN DEFENSE

By Larry Ashmun from Soft Sector
Piloting your ship across the horizontally moving terrain, you must battle the various enemy spacecraft. You are under attack almost constantly from missiles and bombs, and to make matters worse, your ground patrol people are being picked up by the alien landers. To save them, you must shoot the landers and swoop down to "catch" the falling man. This fast action game requires skill and rapid reflexes. The model III version makes excellent use of that model's special graphic features.

Tape...\$15.95 Disk...\$19.95

MONEY MANAGER

By Andrew P. Bartorillo from Acorn
A management tool for the home budget, it keeps track of your checkbook and provides for easy budget allocation. You can store information on up to 100 checkbook entries per month (250 with 48K), specify automatic withdrawals, keep records of tax deductibles, record expenses by category, even break up charge account payments into the proper categories.

32K disk...\$39.95



MISSILE ATTACK

By Philip Oliver from Adventure Int.
You must use your twin silos of ABMs to fend off barrage after barrage of enemy missiles that rain down toward your cities. As your skill increases so does the difficulty and speed of this machine language arcade game. Watch the skies and may your aim be true! MISSILE ATTACK has sound and fast-moving graphics galore.

16K tape...\$14.95 32K disk...\$20.95



By Chuck Acree from Acorn
A comprehensive genealogical program. It lets you set up a database to display/print a complete "pedigree" for any family member or a 3-generation chart. The program will also display a U.S. outline map showing migration across the country. Capacities: 16K tape: 45-55 ancestors. 32K tape: 175; disk: 100. 48K tape: 300; disk: 225.

16K Tape or Disk...\$29.95



SYSTEM SAVERS

By Tom Stibolt from Acorn
This two-program package will make "SYSTEM" use and programming easier for you. FLEXL lets you make backup copies of any "SYSTEM" format tape. This usually means easier loading and lets you store the original for security. FLEXL copies also display the filename of each program as it loads. TDISK lets you save any "SYSTEM" format tape onto disk. Why wait for slow tape loading? TDISK files load in seconds.

Two Program Pack...\$14.95

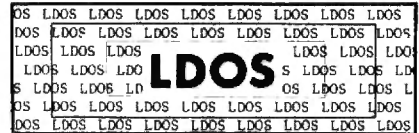

From Lobo
An advanced operating system that offers benefits to everyone from novice to advanced system programmers. LDOS comes with one of the most complete and well written documentation books ever, with easy-to-follow instructions to get started plus a wealth of advanced information for when you need it. Completely device independent, LDOS provides for routing, linking, setting, and filtering of the input/output of a number of peripherals. Up to eight disk drives are supported in almost any mixture: 5", 8", single/double density, up to 80 tracks, even hard disks.

Disk with manual: \$129.95
Specify model I or III

THE DOCUMENTER

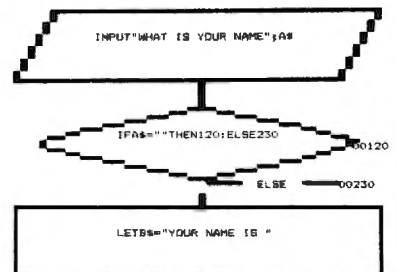

From P80NUT Software
If you would love to be able to document your programs with a flowchart this program is for you. THE DOCUMENTER will produce a logical flowchart directly from any suitable BASIC program and print it on the screen or most lineprinters. You get a flowchart and branch map that will help you follow program flow and aid your debugging efforts.

16K tape...\$19.95 32K tape...\$19.95
48K tape...\$19.95 48K disk...\$39.95

ACCEL 2 BASIC COMPILER

From Allen Gelder
Turns your BASIC program into a machine language/BASIC hybrid that may run many times faster. For those who plan to sell their programs, compiling by ACCEL 2 offers the additional advantage of protection: the source code and REMarks are not included in the compiled version.

While all compilers may require some modification of the BASIC program (usually because of improper structuring), we have found that ACCEL 2 requires the least, and even works with program "tricks" like string-packing, etc.

ACCEL 2 works with models I or III, requires a minimum amount of memory, supports either disk or tape (with TSAVE, optional at \$9.95), and does not require extensive rewriting of your BASIC programs. Unlike other compilers, no royalty is required when selling ACCEL-compiled programs.

Supplied on tape for 16-48K...\$88.95
©1982, The Program Store, Inc.

THE PROGRAM STORE • Dept 8 E 205 Box 9606 • 4200 Wisconsin Ave, NW • Washington, D.C. 20016

80

Item	Price	Postage \$1.00	name _____
_____	_____	Total _____	addr _____
Specify model: <input type="checkbox"/> I <input type="checkbox"/> III <input type="checkbox"/> Color		<input type="checkbox"/> CHECK <input type="checkbox"/> VISA	city _____ state _____ zip _____
		<input type="checkbox"/> MASTERCARD MC Bank # _____	Card # _____ Exp _____

A way to get an extra day off.

Model III Biorhythms

Linda Anderson
1188 Olive Branch Lane
San Jose, CA 95120

I figured the DATM subroutine in the TRSDOS Manual would make a good biorhythm program. According to the theory of bio-

rhythms, each person is influenced from the moment of birth by three rhythms: a 23-day physical rhythm, a 28-day emotional rhythm and a 33-day intellectual rhythm. Each cycle can be shown as a sine wave. The positive half of the wave denotes

days of greater efficiency and the negative half days of less efficiency. There are critical days—days when the wave crosses the axis. These are days of instability or vulnerability.

Days Between Days

The program creates three sine waves on 23, 28, and 33 day cycles, with each beginning point determined by the number of days since birth. DATM computes the number of days between two dates. On entry, DATM expects:

B = 1 function switch—compute difference in dates
HL points to string MM/DD/YYYY MM/DD/YYYY with the earlier date coming first
DE points to a 5 byte output field JJJJ

But when Basic calls a user's external subroutine, it passes its arguments as:

A = 3 denotes argument is a string
DE points to string descriptor:
(DE) = length of string
(DE + 1, DE + 2) = address of string

To bridge the gap between Basic and DATM, I wrote a machine language relocatable subroutine BIOR/SUB (Program Listing 1). This routine expects the string from Basic to look as follows:

```
"MM/DD/YY MM/DD/YYYY JJJJ"
```

The first 10 bytes contain the earlier date. The next 10 bytes contain a later date. The last five

bytes hold the number of days difference in string form.

BIOR/SUB checks for string length of 27; puts the string address in HL; computes DE = HL plus 22, the address of JJJJJ; and sets B equal to one (function switch for DATM). It then calls DATM64 (change this call to 06C60H for DATM32). DATM replaces JJJJJ of the input string with the number of days difference in the two dates in string form, accessed from Basic. On return from DATM, BIOR/SUB restores DE and returns to Basic.

The problem is getting BIOR/SUB on disk, to be accessed by my Basic program. Since I do not have an Assembler in TRSDOS, I used the Debug monitor:

```
>DEBUG ON      turns on Debug monitor
>DEBUG        transfers control to Debug monitor
              change memory at 8100H
              cursor to 8100H
?M A=8100      change memory at 8100H
(F1)
Enter code as shown in BIOR/SUB assembly
for A=8100-A=811B (see Listing 1)
(F2)          effects changes
?S           return to system
>DUMP BIOR/SUB START=8100, END=8120, RORT=R
```

I pulled the address of 8100H

The Key Box

Basic Level II
Model II
TRSDOS 1.2
2 Disk Drives
Diablo 1650 printer

"TOO MUCH" FOR RADIO SHACK!

Radio Shack REFUSED to include MISADVENTURE #1 in their SOURCEBOOK due to our description of the game!



- #0201 Misadventure #1 [Madam Rosa's Massage Parlor]
- #0202 Misadventure #2 [Wet T-Shirt Contest]
- #0301 Dohne' Bugg [Adventure-Decoder]

MADAM ROSA'S MASSAGE PARLOR & WET T-SHIRT CONTEST are slightly naughty ribald & risque' games played in the adventure-format.

IN MISADVENTURE #1 the player has to make his way from the sleazy deserted WHARFS, gain admittance to the ancient SPEAKEASY, and attempt to discover the hidden photographs of the politician's beautiful daughter! Brave the deadly alleys, hallways, and traps. Avoid the BOUNCER and the other characters of questionable reputation! Play in the rigged CARD GAME if you dare! Discover why the old man died with a smile on his face! Find out why the WIND prefers cheap booze! Above all, try to escape without needing any injections of penicillin!!!

WET T-SHIRT CONTEST is the second in our series of MISADVENTURES!

DOHNE' BUGG is an ADVENTURE-DECODER. Tired of hearing that a game has many (sometimes over 100) commands that are accepted - but you are not told what the commands are? This machine language program actually displays on the screen all LOCATIONS that are to be found, all VERBS that interact in the game, and all ACTIONS that result! A MUST FOR ALL SERIOUS ADVENTURERS! Very helpful when 'stuck' in a machine-language adventure program!

All programs work on 16k Model I & III \$15.00 EA
Immediate shipment - check or credit cards & phone orders accepted.

←379

out of the air. If you have a 32K machine, lower the address and change the DATM address as earlier noted. Now we have a machine language subroutine BIOR/SUB, on disk to be read from Basic, to interface Basic to DATM.

The Program

The program to compute biorhythms is really very simple. BIOR/PRG computes Biorhythms for a specified month and year, given the month, day and year of birth. In Program Listing 2 lines 40 and 50 read BIOR/SUB and DATM64 from disk and line 60 defines 8100H as the address of the user subroutine called in line 120. In line 130, XP, XE, XI are the increments in radians for each wave. The beginning arguments for each sine wave, BP, BE, BI, are computed in line 160. Line 200 begins a loop: For each day of the month, the sine for each rhythm is computed and displayed. An option lists the biorhythm as shown in Fig. 1. On the CRT, the waves go across the screen, while they go down the page on the List device.

Put all this together and find

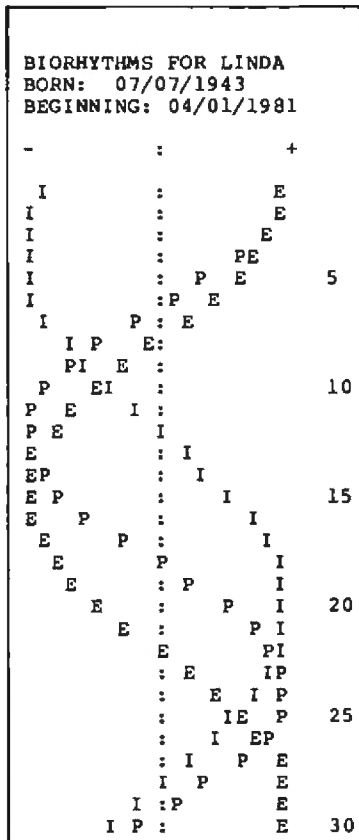

Fig. 1.

out when to schedule your racquetball match (on a physical high), when not to make an important decision (on an intellectual critical day), and when not to

ask for a raise (on an emotional low). If it all sounds like a lot of phooey, you can still have fun watching all the pretty sine waves go by. ■

Linda Anderson is a former systems programmer, and is now Director of Computer Operations for her husband's law office.

```

EC60 =          DATM64 EQU      0EC60H ;ADDRESS OF DATM SUBROUTINE
8100          ORG      8100H
8100 1A          LDAX   D          ;A=STRING LENGTH
8101 FE1B       CPI     27         ;MUST BE =27
8103 C0         RNZ     D          ;RETURN IF NOT
8104 D5         PUSH   D          ;SAVE STRING DESCRIPTOR ADDRESS
8105 13         INX    D          ;POINT TO STRING ADDRESS
8106 1A         LDAX   D          ;LOWER BYTE OF ADDRESS
8107 5F         MOV    L,A        ;TO L REG
8108 13         INX    D
8109 1A         LDAX   D          ;UPPER BYTE OF ADDRESS
810A 67         MOV    H,A        ;TO H REG
810B E5         PUSH   H          ;SAVE STRING ADDRESS
810C 111600     LXI    D,22       ;COMPUTE ADDRESS OF "JJJJJ"
810F 19         DAD    D          ;(HL)=ADDRESS OF "JJJJJ"
8110 EB         XCHG                ;(DE)=ADDRESS OF "JJJJJ"
8111 E1         POP    H          ;(HL)=ADDRESS OF DATE STRING
8112 0601       MVI    B,1        ;DATM FUNCTION SWITCH
8114 CD60EC     CALL   DATM64
8117 D1         POP    D          ;RESTORE STRING DESCRIPTOR ADDRESS
8118 C9         RET
8119          END

```

Program Listing 1. Subroutine BIOR/SUB

```

5 CLS
10 CLEAR 200,33000
20 DEFINT N,M,D,J,I,K
30 DEFDBL C,X,B
40 SYSTEM "BIOR/SUB"
50 SYSTEM "DATM64"
60 DEFUSR0=&H8100
65 CLS
70 PRINT@(10,30),"B I O R H Y T H M S"
80 PRINT@(15,30),"by Linda Anderson"
85 PRINT@(17,20),"":INPUT "WHAT IS YOUR NAME";NM$
90 PRINT@(19,20),"":INPUT "WHAT IS YOUR BIRTHDATE (MM/DD/YYYY)";B$
100 PRINT@(21,20),"":INPUT "MONTH/YEAR TO BEGIN BIORHYTHMS (MM/YYYY)";D$
105 PRINT@(23,20),"":INPUT "DO YOU WANT A LISTING (Y/N)";L$
110 D$=LEFT$(D$,3)+"01/"+RIGHT$(D$,4):S$=B$+" "+D$+" JJJJJ"
120 S$=USR0(S$)
130 CR=.0175*360:XP=CR/23:XE=CR/28:XI=CR/33
140 J$=RIGHT$(S$,5):IF J$="JJJJJ" THEN 300
150 ND=VAL(J$)
160 BP=(ND MOD 23)*XP:BE=(ND MOD 28)*XE:BI=(ND MOD 33)*XI
170 CLS:PRINT@(0,0),"BIORHYTHMS FOR ";NM$," ",BORN:" ";B$," ",BEGINNING:" ";D$
175 PRINT@(1,5),"+":PRINT@(21,5),"-"
180 IF L$="Y" THEN GOSUB 450
185 M=VAL(LEFT$(D$,2))
190 IF M=2 THEN D=29 ELSE IF (M=4 OR M=6 OR M=9 OR M=11) THEN D=30 ELSE D=31
200 FOR K=1 TO D STEP 1
210 JP=11-INT(SIN(BP)*10):BP=BP+XP
220 JE=11-INT(SIN(BE)*10):BE=BE+XE
230 JI=11-INT(SIN(BI)*10):BI=BI+XI
240 KK=K*2+10
250 PRINT@(11,KK),"-" :PRINT@(JP,KK),"P" :PRINT@(JE,KK),"E" :PRINT@(JI,KK),"I"
260 IF K MOD 5 = 0 THEN PRINT@(22,KK),K
265 IF L$="Y" THEN GOSUB 400
270 NEXT K:PRINT@(23,0),"SHALL WE GO AGAIN (Y/N)? ";
275 IF L$="Y" THEN LPRINT CHR$(12)
280 LINE INPUT A$: IF A$="Y" THEN 65
290 END
300 PRINT "ERROR: ",S$
310 GOTO 280
400 PL$=SPACES$(25)
410 MID$(PL$,11,1)=" ":MID$(PL$,22-JP,1)="P":MID$(PL$,22-JE,1)="E"
420 MID$(PL$,22-JI,1)="I":IF K MOD 5=0 THEN MID$(PL$,23,3)=STR$(K)
430 LPRINT PL$
440 RETURN
450 LPRINT "BIORHYTHMS FOR ";NM$:LPRINT "BORN: ";B$
455 LPRINT "BEGINNING: ";D$:LPRINT:LPRINT"-":
470 LPRINT:RETURN

```

Program Listing 2. BIOR/PRG



Make 'em with a Centronics 737.

Super Banner

Ron Balewski
412 East Ridge Street
Nanticoke, PA 18634

I wrote a Basic banner generating program to break in my new Centronics 737 printer. The biggest problem with this program was coming up with good looking letters. Although I cannot draw free-hand, I was able to come up with an acceptable character set.

I wanted to input the data for

the letters as a series of numbers instead of strings of characters (because it is easier to type a few numbers than to type a string of 35 asterisks). I will explain the technique I used so you can customize the program. You may find this technique useful if you should have to randomly access a large group of Data statements in one of your programs.

Trial and Error

How could I get to the set of

data I wanted? First, I Restored the data before each block letter printed and then read through the data until I came to the data for the letter I wanted to print. If I wanted to print the nth block letter, I read through all the data for n-1 letters before arriving at useful data.

Although this method worked, it was much too slow. I use a very large data base consisting of the capital and small letters, numerals and punctuation; to print a block letter located near

the end of the data required much useless reading. Because my printer is slow enough without adding processing delays, I had to find a faster way.

Next, I used an array for more speed. Arrays can be accessed directly at any point without reading from the beginning. I set up a huge data array to store all the numbers from the Data statements sequentially and another much smaller array to point to the start of each letter. For example, if I wanted to access the data for the fifth block letter, the fifth element of the small index array would tell me where to start reading the data array. I would then access the data array sequentially from that point to the end of the data for the fifth letter.

This method worked and there were absolutely no delays between printing block letters. There was only one slight problem: All the Data statements and the monstrous data array would not fit in memory at the same time. And I have 48K! What could I do? I did not want to cut down the number of banner-size characters I could print

Program Listing 1. Super Banner

```

1 REM ***** SUPER - BANNER *****
2 REM BY RON BALEWSKI
10 CLEAR500:DEFINTA-Z:DIMMGS(10),SC$(10),PS(100,2):LS$="ABCDEFGHIJKLMNPOQRS
TUWVXYZ 1234567890abcdefghijklmnopqrstuvwxyz. !%$#@'():*-=+/?<`"
12 NL=85
14 NF=1
15 CLS:PRINT"JUST A MINUTE, PLEASE.":PRINT:PRINT:FORK=1TONL:PS(K,1)=PEEK(16
639):PS(K,2)=PEEK(16640)
17 READLP:IFLP=1000THENNEXTKELSEGOTO17
19 FORK=1TO10:PRINT"INPUT MESSAGE ";K:INPUTMGS(K):IFMGS(K)<>"END"THENS$(K
)="":INPUT"PRINT CHARACTER (ENTER FOR CORRESPONDING)":SC$(K):PRINT
21 IFMGS(K)="END"THENK=K-1:GOTO25
23 NEXTK
25 NH=K
27 FORKA=1TONM
28 CLS:PRINT"START MESSAGE";KA;" ==> ";MGS(KA):PRINT
29 FORKB=1TOLEN(MGS(KA)):PRINTMID$(MGS(KA),KB,1)
31 LI$=MID$(MGS(KA),KB,1)
33 FORKT=1TOLEN(LS$):IFLI$=MID$(LS$,KT,1)THENGOTO35ELSENEXTKT:PRINT"ERROR I
N MESSAGE ";MGS(KA):STOP
35 POKL16639,PS(KT,1):POKE16640,PS(KT,2):READLP
37 IFLP=1000THENGOTO47
38 IFNF=1THENNF=0:IFLP<>2000THENLPRINT" *":ELSEREADLP
39 IFLP>0THENIFSC$(KA)="THENLPRINTSTRING$(LP,L1$):ELSELPRINTSTRING$(LP,SC$
(KA)):
41 IFLP<0THENLPRINTSTRING$(ABS(LP)," "):
43 IFLP=0THENLPRINT" *":NF=1
45 READLP:GOTO37
47 LPRINT" *":LPRINT" *":LPRINT" *":LPRINT" *":NF=1:NEXTKB:FORK=1TO20:LPRINT
":NEXTK
49 NEXTKA
51 CLS:PRINT"END OF PRINT.":PRINT:PRINT:GOTO19
99 REM CAP A
100 DATA3,0,3,0,3,0,3,0,7,0,12,0,3,-5,9,0,3,-9,9,0,3,-14,9,0,3,-16,12,0,-19
,3,-3,9,0,-19,3,-9,9,0,-19,3,-13,9,0,-19,3,-18,9,0,-19,3,-22,9,0,-19,3,-27
,9,0,-19,3,-30,10,0,-19,3,-27,17,0,-19,3,-22,26,0,-19,3,-18,25,0,-19,3,-14,2
5,0,-19,3,-10,25,0,-19,3,-6,25,0
110 DATA-19,3,-2,25,0,-19,26,0,-16,25,0,3,-9,25,0,3,-4,25,0,28,0,24,0,19,0,
15,0,11,0,6,0,3,0,3,0,1000
200 REM CAP B
210 DATA3,-64,3,0,70,0,70,0,70,0,70,0,70,0,3,-31,3,-30,3,0,3,-31,3,-30

```

Program continues

The Key Box

Basic Level II
Model I
32K RAM
Any 80-column printer

Program continued

```

1830 DATA-3,2,0,-4,1,0,1000
1900 REM CAP S
1910 DATA20,-28,9,0,17,-26,18,0,-2,12,-26,23,0,-5,7,-26,27,0,-4,6,-27,29,0,-
3,5,-28,31,0,-2,5,-28,16,-4,13,0,-2,4,-28,13,-11,18,0,-1,4,-28,13,-15,8,0,-
1,4,-27,13,-18,6,0,4,-27,13,-28,5,0,4,-26,13,-22,4,0,3,-26,14,-23,4,0
1920 DATA3,-26,13,-24,4,0,3,-25,13,-26,3,0,3,-25,13,-26,3,0,4,-23,13,-27,3,
0,-1,3,-22,13,-27,4,0,1,-28,14,-27,4,0,-1,6,-14,-27,4,0,-2,7,-14,14,-
28,4,0,-2,9,-11,15,-27,5,0,-3,10,-6,17,-27,5,0,-3,33,-26,6,0
1930 DATA-4,31,-26,6,0,-5,29,-26,5,0,-7,25,-26,5,0,-9,21,-26,11,0,-11,16,-2
7,16,0,-14,10,-27,19,0,1000
2000 REM CAP T
2010 DATA-57,13,0,-57,13,0,-68,18,0,-63,7,0,-65,5,0,-66,4,0,-67,3,0,-67,3,0
,-67,3,0,-67,3,0,-67,3,0,-67,3,0,-67,3,0,-67,3,0,-67,3,0,-67,3,0,-67,3,0,-67,3,0
,-67,3,0
2020 DATA-67,3,0,-66,4,0,-65,5,0,-63,7,0,-60,18,0,-57,13,0,-57,13,0,1000
2100 REM CAP U
2110 DATA-67,3,0,-67,3,0,-15,55,0,-11,59,0,-8,62,0,-6,64,0,-5,65,0,-4,66,0,-
3,15,-49,1,0,-3,18,-54,3,0,-2,9,0,-2,8,0,-1,8,0,-1,7,0,7,0,7,0,7,0,7,0,-1,
6,0,-1,7,0,-2,7,0,-2,8,0,-3,8,-56,3,0,-4,9,-54,3,0,-5,10,-52,3,0,-7,11,-49,
3,0
2120 DATA-11,59,0,-15,55,0,-67,3,0,-67,3,0,-67,3,0,-67,3,0,1000
2200 REM CAP V
2210 DATA-67,3,0,-67,3,0,-65,5,0,-61,9,0,-57,13,0,-53,17,0,-49,21,0,-45,25,0,-
41,24,-2,3,0,-37,24,-6,3,0,-33,24,0,-29,24,0,-25,24,0,-21,24,0,-17,24,0,-
13,24,0,-9,28,0,-29,0,-5,28,0,-9,11,0,-13,12,0,-17,12,0,-21,12,0
2220 DATA-25,12,0,-29,12,0,-33,12,0,-37,12,-41,12,-14,3,0,-45,12,-18,3,0,-
49,13,-5,3,0,-53,13,-1,3,0,-57,13,0,-62,8,0,-66,4,0,-67,3,0,-67,3,0,-67,3,
0,1000
2300 REM CAP W
2310 DATA-67,3,0,-67,3,0,-64,6,0,-57,13,0,-58,20,0,-43,27,0,-37,33,0,-39,40
,0,-24,40,-3,3,0,-17,39,-11,3,0,-10,40,0,-4,40,0,37,0,-5,25,0,-10,16,0,-13,
15,0,-19,15,0,-24,14,0,-29,14,0,-34,13,-28,3,0,-37,14,-16,3,0,-42,13,-18,5,
0,-47,13,-1,9,0
2320 DATA-51,19,0,-51,19,0,-47,23,0,-43,27,0,-38,27,-2,3,0,-34,26,-7,3,0,-2
9,27,0,-25,27,0,-20,27,0,-16,27,0,-11,27,0,-7,27,0,-3,27,0,25,0,-7,15,0,-12
,14,0,-15,15,0,-20,14,0,-25,14,0,-29,15,0,-34,14,0,-38,14,0
2330 DATA-43,13,0,-47,13,0,-47,14,-6,3,0,-51,14,-6,3,0,-56,14,0,-60,18,0,-65,5
,0,-67,3,0,-67,3,0,-67,3,0,1000
2400 REM CAP X
2410 DATA3,-64,3,0,3,-64,3,0,-62,5,0,3,-60,7,0,3,-57,10,0,4,-53,13,0,7,-4
8,15,0,3,-1,5,-44,17,0,3,-3,6,-38,20,0,3,-6,5,-34,22,0,3,-8,6,-28,20,-2,3,0
,-14,5,-24,20,-4,3,0,-16,6,-18,20,0,-19,5,-14,20,0,-21,6,-8,20,0,-24,5,19,2
0,0,-26,24,0
2420 DATA-28,28,0,-26,19,0,-23,20,0,-21,21,0,-18,26,0,-16,28,0,-14,26,0,-13,20,
-10,6,0,-11,20,-15,5,0,-8,20,-20,6,0,3,-3,20,-25,5,-11,3,0,3,-1,19,-30,6,-0
,3,0,21,-35,5,-6,3,0,18,-40,6,-3,3,0,16,-45,5,-1,3,0,13,-50,7,0,11,-55,4,0,
9,-58,3,0
2430 DATA6,-61,3,0,4,-63,3,0,3,-64,3,0,3,-64,3,0,1000
2500 REM CAP Y
2510 DATA-67,3,0,-67,3,0,-66,4,0,-63,7,0,-60,18,0,-57,13,0,-55,15,0,-52,18,
0,-49,21,0,-46,17,-4,3,0,-43,18,0,-40,18,0,-37,18,0,3,-31,18,0,3,-28,18,0,
46,8,0,3,0,30,0,35,0,34,0,3,-28,6,0,3,-31,6,0,-37,5,0,-40,5,0,-42,6,0,-45,
5,0,-48,6,0
2520 DATA-56,-10,3,0,-54,6,-7,3,0,-57,6,-4,3,0,-60,6,-1,3,0,-63,7,0,-65,5
,0,-67,3,0,-67,3,0,-67,3,0,1000
2600 REM CAP Z
2610 DATA1,-54,15,0,4,-51,15,0,7,-54,9,0,10,-54,6,0,13,-53,4,0,16,-51,3,0,1
9,-48,3,0,3,-2,17,-45,3,0,3,-4,18,-42,3,0,3,-7,17,-40,3,0,3,-10,17,-37,3,0,
3,-13,17,-34,3,0,3,0,3,-13,3,0,3,-19,17,-28,3,0,3,0,3,-22,17,-25,3,0,3,-25,1
7,-22,3,0
2620 DATA3,-28,17,-19,3,0,3,-31,17,-16,3,0,3,-34,17,-13,3,0,3,-36,17,-11,3,
0,3,-39,17,-8,3,0,3,-42,17,-5,3,0,3,-45,17,-2,3,0,3,-48,19,0,3,-51,16,0,4,-
52,14,0,6,-53,11,0,9,-53,8,0,15,-50,5,0,15,-53,2,0,1000
2700 REM BLANKSPACE
2710 DATA0,0,0,0,0,0,0,0,0,0,0,0,0,0,0,0,0,0,0,0,0,0,0,0,0,0,0,0,0,0,0,0,0,0
2800 REM 1
2810 DATA4,-53,3,0,4,-53,3,0,61,6,62,6,63,6,65,6,67,0,70,0,4,0,4,0,1000
2900 REM 2
2910 DATA3,-38,18,0,8,-31,18,0,12,-26,11,-3,0,0,14,-24,11,-7,6,0,16,-22,11,-
9,6,8,18,-2,5,-22,9,-12,5,0,18,-4,5,-22,6,-15,4,0,18,-3,5,-43,8,0,18,-6,5,-
43,4,0,18,-7,5,-42,5,0,18,-0,6,-41,4,0,18,-8,7,-48,4,0,18,-9,7,-48,4,0,18,-
10,8,-38,4,0
2920 DATA10,-18,9,-30,3,0,18,-11,9,-36,4,0,18,-12,9,-35,3,0,18,-13,9,-33,4,
0,18,-14,9,-31,5,0,18,-14,11,-28,5,0,18,-15,11,-25,7,0,18,-16,12,-21,9,0,18
,-17,12,-17,11,6,0,18,-18,15,-6,18,0,18,-19,37,0,18,-20,35,0,18,-22,31,0
2930 DATA18,-23,28,0,-2,11,-23,21,0,-7,8,-26,18,0,-12,3,0,1000
3000 REM 3
3010 DATA-10,7,-36,7,0,-7,12,-32,12,0,-5,15,-30,15,0,-4,4,-2,10,-30,18,-2,4
,0,-3,4,-4,0,-32,0,4,0,-2,4,-7,4,-36,4,-7,4,0,-2,3,-68,3,0,-1,4,-68,4,0,-
-1,3,-62,3,0,-1,3,-29,4,-29,3,0,3,-30,4,-30,3,0,3,-30,4,-30,3,0,3,-30,4,-30
,3,0,3,-30,4,-30,3,0
3020 DATA4,-29,4,-29,4,0,-29,4,-29,4,0,-1,3,-29,4,-29,3,0,-1,4,-28,4,-28,
4,0,-1,5,-27,4,-27,5,0,-2,5,-25,6,-25,5,0,-2,6,-23,8,-23,6,0,-3,7,-19,12,-1
9,7,0,-4,8,-15,16,-15,9,0,-4,13,-6,24,-6,13,0,-5,30,-1,29,6,-6,20,-3,27,0
3030 DATA-8,25,-5,3,25,0,-10,21,-9,21,0,-14,15,-13,17,0,-19,14,0
3100 REM 4
3110 DATA-24,1,0,-24,3,0,-24,5,0,-24,7,0,-24,3,-2,4,0,-24,3,-4,4,0,-24,3,-6
,4,0,-24,3,-8,4,0,-24,3,-10,4,0,-24,3,-12,4,0,-24,3,-14,4,0,-24,3,-16,4,0,-
24,3,-18,4,0,-24,3,-20,4,0,-24,3,-22,4,0,-24,3,-24,4,0,-24,3,-26,4,0,3,-2
1,3,-20,4,0
3120 DATA61,0,63,0,65,0,67,0,69,0,70,0,3,-21,3,0,3,-21,3,0,-24,3,0,-24,3,0,-
-23,5,0,-21,9,0,-16,19,0,-16,19,0,1000
3200 REM 5
3210 DATA-10,7,0,-6,13,0,-4,5,-1,10,0,-3,4,-3,10,0,-2,4,-5,0,-15,33,0,-1,4,-
8,4,-19,31,0,-1,3,-33,3,-17,10,0,-1,3,-34,4,-15,10,0,3,-36,4,-14,10,0,3,-3
7,4,-13,10,0,3,-37,4,-13,10,0,3,-38,4,-12,10,0,3,-38,4,-12,10,0,4,-38,4,-11
,10,0
3220 DATA4,-38,4,-11,10,0,-1,3,-38,4,-11,10,0,-1,3,-37,5,-11,10,0,-1,4,-36,
4,-12,10,0,-1,4,-35,5,-12,10,0,-1,5,-33,6,-12,10,0,-2,5,-30,7,-13,10,0,-2,7
,-26,9,-13,10,0,-3,8,-19,13,-14,10,0,-4,10,-11,17,-15,10,0,-5,36,-16,10,0
3230 DATA-6,33,-18,10,0,-7,30,-20,10,0,-9,25,-23,11,0,-12,19,-28,11,0,-16,9
,-41,4,0,1000
3300 REM 6
3310 DATA-28,16,0,-21,29,0,-14,40,0,-9,48,0,-6,53,0,-4,57,0,-3,21,-9,5,-8,1
7,0,-2,14,-20,4,-16,9,0,-1,13,-22,4,-19,7,0,-1,10,-26,4,-20,6,0,-3,7,-13,10,0,-
2,8,6,0,7,-31,4,-21,5,0,5,-34,4,-21,5,0,4,-35,4,-22,4,0,3,-37,4,-21,5,0,3,-
37,4,-22,4,0
3320 DATA4,-36,4,-22,4,0,4,-36,4,-22,4,0,5,-34,4,-22,4,0,6,-32,5,-22,4,0,-1
6,-29,6,-22,4,0,-1,8,-25,0,-11,4,-6,4,0,-2,10,-19,10,-10,8,-3,4,0,-3,13,-8
,17,-9,10,-1,4,0,-4,36,-10,14,0,-5,34,-12,11,0,-7,31,-15,7,0,-9,27,0,-11,22
,0,-14,13,0,1000
3400 REM 7
3410 DATA-56,3,0,-56,11,0,-59,11,0,-60,10,0,-60,10,0,-60,10,0,14,-46,10,0,2
5,-35,10,0,31,-29,10,0,35,-25,10,0,38,-22,10,0,10,-0,23,-19,10,0,2,-26,16,-

```

Program continues

POKE PS(n,1) and PS(n,2) into the data pointer.

After that, the program reads the data and uses it to control printing until it reaches a 1000 (end of letter indicator). Then it cycles back and repeats the entire process with the next letter.

How To Use It

After you load and run the program, it will pause for several minutes while the computer reads through the data and sets up its index table. Eventually the computer will ask you to input a message. Remember to shift for small letters. A cent sign is available by typing a shift @. After you enter the message, the computer will ask you for a print character. The computer will print the entire banner using this character unless you specify Corresponding (by pressing Enter). Corresponding means that each character in that banner will be made up of its corresponding printed character. For example, the A will be made up of As, the 4 printed in 4s, and so on. The computer will then ask you for the next message. If you want no more banners, type END as the next message.

After you input all the messages, the computer will print the banners. It also constantly displays exactly what it is doing on the video screen so you can keep track of how much remains to be printed without digging through the printout.

This version of the Super Banner program will run on any ten characters-per-inch, six lines-per-inch printer because I am not using any of the fancy control features in my 737. The program is designed for 9 1/2 inch printers and will not center banners on a tractor printer with which you use 14 7/8 inch paper.

The Alternate Version

Program Listing 2 shows an alternative version of this program, Super Banner II. Only the program listing is shown because the data it uses (and its principle of operation) are identical to the Super Banner program's. This program uses some of the Centronics 737's special functions to produce smaller, denser block letters about half

SAVE / on Software and Hardware for TRS-80

CHEXTEXT®

Let your TRS-80® do the proofreading on your SCRIPSIT® text files!

Features of this program include:

- Complete dictionary maintenance including the addition and deletion of words.
- Menu driven for ease of operation.
- Spelling Checker
- FREE expanded dictionaries available, depending on your drive storage capabilities.

NEW LOWER PRICE \$59.95

MODEL III PRICE LIST

(All 48K with TANDON drives)

1 single sided 40 track drive	\$1695.00
2 single sided 40 track drives	1895.00
1 dual sided 40 track drive	1820.00
2 dual sided 40 track drives	2145.00
2 single sided 80 track drives	2175.00
2 dual sided 80 track drives	2395.00
with RS-232 C Add	115.00

The above computers include NEWDOS 80 Version 2.0.

NOTE: These Model III computers contain Apparat installed disk drives and memory. They are warranted by Apparat, Inc. for 90 days.

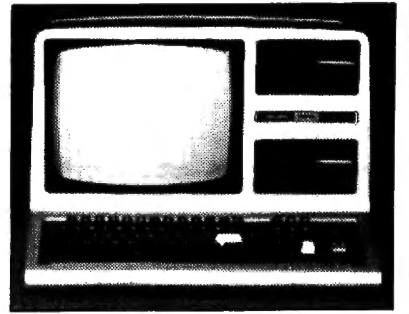

MISCELLANEOUS SUPPLIES

DISKETTES

Double density-soft sectored-replacement guaranteed. Spindle/Hub protected. (5¼" only)

Verbatim Datalife 5¼" 40 track	\$24.95
Apparat's No Name 5¼" 40 track	\$19.95
Verbatim Datalife 8" model II	\$39.95

PAPER

9½"x11" blank white, tractor feed paper, full box 15# or 20#	\$24.95
14½"x11" green bar, tractor feed paper, full box	\$34.95
3½"x15/16" tractor feed mailing labels	\$19.95

OTHER

5¼" plastic library case	\$ 1.95
8" plastic library case	\$ 4.95
5¼" Flip-sort	\$18.95
8" Flip-sort	\$31.95
16K memory kits	\$19.95

APPARAT'S PROM BLASTER

An eeprom programmer for all 25 X X and 27 X X chips. TRS-80®

MOD I & III	\$149.00
CABLE	\$ 17.95

BUS EXTENDER

mini version with 2 card slots and no enclosure	\$ 69.95
---	----------

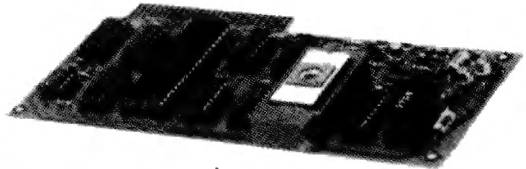

SPECIAL - FREE GRAFTRAX

with EPSON MX-80 Printers

MX-80 \$499.00

MX-80F/T \$575.00
with Graftrax, add \$79.95

MX-100 \$775.00

Printer Cables \$24.00
(Specify Computer Type)

WE ALSO STOCK OKIDATA & NEC PRINTERS
CALL FOR PRICES



ASSORTED ITEMS OF INTEREST

MICRO CLINIC, Mod I \$24.95, Mod III \$29.95

The ultimate in memory & disk diagnostics

MEAL MASTER, Mod I & III Disk \$24.95
meal planning & grocery shopping aid

FLEXTXT/80 (requires Graftrax) \$34.95
utilize the additional features of the MX-80
printers under model I & III scripsit

MICRO ACCOUNTING SYSTEM, \$479.00

Interactive G/L, A/R, A/P & checkbook manager

UNI-TERM/80, \$89.00

Universal terminal program that takes advantage
of the extended NEWDOS/80 commands

BASIC BETTER & FASTER BOOK, \$23.95

NEW LOWER PRICES ON TANDON DISK DRIVES

Complete with power supply, chassis & configured for
TRS-80® Model I or III

- Single sided 40 track \$285.00
- Dual 40 or Single 80 track \$415.00
- Dual sided 80 track \$515.00
- **Special - 2 Dual sided 80's \$999.00**
(ADDS ALMOST 1 5 MEGABYTES OF STORAGE
TO A D D, MOD I OR A MOD III)

MODEL I DOUBLE DENSITY PACKAGE

Converts a standard TRS-80 Model I
to Double Density.

Apparat Doubler & NEWDOS/80 V 2.0

\$278.00 value for only \$219.00

Doubler alone \$129.00



NEWDOS 80 Version 2.0

The most sophisticated DOS ever produced for the TRS-80® Models I and III. It provides the user with "MAINFRAME" power on a "MICRO".

Some Features available are:

- Jobstream Control Language
- Mod I/Mod III Diskette interchangeability
- Double Density Support on Model I
- Pagenation of BASIC listings on the screen
- Basic program single stepping
- Dynamic variable manipulation
- Multiple array sorts with BASIC CMD
- Complete technical support provided

All this plus much more for only

\$149.00

InfoWorld Software Report Card

**NEWDOS/80
Version 2.0**

	Poor	Fair	Good	Excellent
Performance	<input type="checkbox"/>	<input type="checkbox"/>	<input checked="" type="checkbox"/>	<input type="checkbox"/>
Documentation	<input type="checkbox"/>	<input type="checkbox"/>	<input checked="" type="checkbox"/>	<input type="checkbox"/>
Ease of Use	<input type="checkbox"/>	<input type="checkbox"/>	<input checked="" type="checkbox"/>	<input type="checkbox"/>
Error Handling	<input type="checkbox"/>	<input type="checkbox"/>	<input checked="" type="checkbox"/>	<input type="checkbox"/>



Apparat, Inc.

"On-going Support for Microcomputers"

4401 S. Tamarac Pkwy • Denver, CO 80237 • (303) 741-1778 • (800) 525-7674

Scrpsit & TRS 80 are a registered trademark of Tandy Corporation

Freight F O B Denver call for shipping charges Foreign Orders shipped Air Freight

✓ 512



Program continued

```

16,10,0,-32,14,-14,10,0,-36,12,-12,10,0,-39,11,-10,10,0,-42,9,-9,10,0,-45,8
,-7,10,0
3420 DATA-48,6,-6,10,0,-50,6,-4,10,0,-52,5,-3,10,0,-54,4,-2,10,0,-56,14,0,-
58,12,0,-60,10,0,-62,8,0,-64,6,0,-67,3,0,-68,2,0,1000
3500 REM B
3510 DATA-11,9,-30,7,0,-8,15,-23,13,0,-6,19,-18,19,0,-5,8,-5,9,-13,23,0,-4,
6,-11,7,-10,13,-6,7,0,-3,5,-15,6,-8,10,0,-14,4,0,-2,5,-18,5,-6,10,-16,4,0,-2,
4,-21,4,-4,9,-19,4,0,-1,4,-23,4,-2,9,-21,4,0,-1,4,-24,14,-22,4,0
3520 DATA-1,3,-26,12,-24,4,0,-26,12,-24,4,0,-26,12,-24,4,0,-25,4,0,-27,11,-25
4,0,-23,-27,10,-26,4,0,-26,11,-27,3,0,-25,10,-28,3,0,-24,11,-28,3,0,-1
4,-23,11,-28,3,0,-1,4,-22,13,-26,4,0,-2,4,-21,13,-26,3,0,-2,5,-19,10,-1,4
,-25,3,0
3530 DATA-3,5,-17,10,-3,3,0,-25,3,0,-3,6,-15,10,-5,3,-23,3,0,-4,7,-11,11,-7,4
,-20,4,0,-6,8,-5,12,-10,6,-15,5,0,-8,22,-12,9,-7,7,0,-10,10,-16,19,0,-12,13
,-21,14,0,-16,7,-26,7,0,1000
3600 REM 9
3610 DATA-43,13,0,-37,22,0,-34,27,0,-10,7,-15,31,0,-8,11,-12,14,0,-6,14,-10
,36,0,-5,4,-1,10,-9,17,-8,13,0,-4,4,-3,8,-10,10,-19,10,0,-3,4,-6,4,-11,8,-2
5,8,0,-2,4,-22,6,-29,6,0,-1,4,-22,5,-32,6,0,-1,4,-22,4,-34,5,0,-4,22,4,-36,
4,0
3620 DATA4,-22,4,-36,4,0,-22,4,-37,3,0,-21,4,-37,3,0,-1,4,-22,4,-35,4,0
,-1,5,-21,4,-34,5,0,-2,5,-21,4,-31,7,0,-2,6,-20,4,-29,8,0,-3,6,-20,4,-26,10
,0,-4,7,-19,4,-22,13,0,-6,9,-16,4,-17,16,0,-7,17,-8,5,-9,21,0,-9,57,0,-11,5
,3,0,-13,4,0
3630 DATA-16,4,0,-20,29,0,-26,16,0,1000
3700 REM 0
3710 DATA-31,8,0,-24,22,0,-19,32,0,-16,38,0,-13,44,0,-11,40,0,-9,21,-10,21,
0,-7,18,-20,10,0,-6,15,-28,15,0,-5,13,-34,13,0,-4,11,-40,11,0,-3,18,-44,10,
0,-3,8,-48,0,0,-2,7,-52,7,0,-2,5,-56,5,0,-1,4,-60,4,0,-1,3,-62,3,0,-3,-64,3,
0,-3,-64,3,0
3720 DATA-1,3,-62,3,0,-1,4,-60,4,0,-2,5,-56,5,0,-2,7,-52,7,0,-3,8,-48,0,0,-
3,10,-44,10,0,-4,11,-40,11,0,-5,13,-34,13,0,-6,15,-28,15,0,-7,18,-20,10,0,-
9,21,-10,21,0,-11,48,0,-13,44,0,-16,38,0,-19,32,0,-24,22,0,-31,8,0,1000
3800 REM SM A
3810 DATA-5,6,0,-2,10,0,-1,12,0,-1,13,-12,5,0,15,-9,10,0,16,-7,12,0,6,-4,7,
-6,14,0,4,-7,7,-6,8,-3,3,0,-9,7,-7,4,-5,3,0,3,-11,6,-16,3,0,-1,3,-11,5,-1
6,3,0,-1,3,-12,5,-16,3,0,-1,3,-13,5,-14,4,0,-2,3,-13,4,-13,5,0
3820 DATA-2,3,-14,4,-10,6,0,-3,3,-14,4,-6,9,0,38,0,37,0,36,0,35,0,33,0,30,0
,1000
3900 REM SM B
3910 DATA-67,3,0,-67,3,0,78,0,-1,69,0,-1,69,0,-2,68,0,-2,68,0,-3,67,0,-4,3,
-25,3,0,-3,3,-27,3,0,-2,3,-29,3,0,-1,3,-31,3,0,3,-31,3,0,3,-34,3,0
3920 DATA3,-34,3,0,4,-32,4,0,-1,4,-30,4,0,-1,6,-26,6,0,-1,8,-22,8,0,-2,12,-
12,12,0,-3,34,0,-4,32,0,-6,28,0,-8,24,0,-10,20,0,-12,16,0,-15,10,0,1000
4000 REM SM C
4010 DATA-15,10,0,-11,10,0,-8,24,0,-6,28,0,-4,32,0,-3,34,0,-2,12,-12,12,0,-
1,8,-22,0,0,-1,6,-26,6,0,-1,4,-30,4,0,-3,34,0,3,-34,3,0
4020 DATA3,-34,3,0,3,-34,3,0,4,-33,3,0,4,-32,3,0,-1,3,-32,3,0,-1,4,-30,4,0,-
1,4,-18,4,-7,4,-2,4,-15,8,-4,4,0,-2,5,-13,10,-1,5,0,-3,5,-12,14,0,-4,5,-
12,11,0,-5,6,-12,6,0,1000
4100 REM SM D
4110 DATA-15,10,0,-11,10,0,-8,24,0,-6,28,0,-4,32,0,-3,34,0,-2,12,-12,12,0,-
1,8,-22,0,0,-1,6,-26,6,0,-1,4,-30,4,0,-3,34,0,4,-34,3,0
4120 DATA3,-34,3,0,3,-32,3,0,-2,3,-30,3,0,-3,3,-28,3,0,-3,67,0,-2,68,0,-
2,68,0,-1,69,0,-1,69,0,78,0,-67,3,0,-67,3,0,1000
4200 REM SM E
4210 DATA-15,10,0,-11,10,0,-8,24,0,-6,28,0,-4,32,0,-3,34,0,-2,12,-3,3,-6,12
,0,-1,8,-8,3,-11,8,0,-1,6,-10,3,-13,6,0,-1,4,-12,3,-15,4,0,-13,3,-16,4,0,
3,-14,3,-17,3,0
4220 DATA3,-14,3,-17,3,0,3,-14,3,-16,4,0,3,-14,3,-15,4,0,3,-14,3,-13,6,0,-1
,3,-13,3,-11,8,0,-1,3,-13,3,-7,11,0,-1,3,-13,2,0,-2,3,-12,19,0,-2,4,-11,17
,0,-3,4,-10,15,0,-4,4,-9,12,0,-5,4,-8,9,0,1000
4300 REM SM F
4310 DATA-38,4,0,-38,4,0,-38,4,0,3,-35,4,0,3,-35,4,0,52,0,59,0,63,0,65,0,67
,0,68,0,3,-35,4,-28,7,0,3,-35,4,-22,5,0,-38,4,-24,4,0,-38,4,-25,3,0,-38,4,-
11,4,-16,3,0,-51,8,-7,3,0,-58,10,-4,4,0,-58,17,0,-51,14,0,-53,9,0,1000
4400 REM SM G
4410 DATA2000,-3,2,-5,4,-13,6,0,2000,-1,6,-2,7,-7,14,0,2000,4,-1,14,-2,18,0
,2000,3,-3,35,0,2000,3,-3,7,-1,28,0,2000,3,-3,6,-5,26,0,2000,3,-3,6,-5,9,7
,10,0,2000,3,-3,6,-4,6,-14,0,2000,3,-3,6,-4,10,6,0,2000,3,-3,6,-4,10,6,0,2
,1,4,0
4420 DATA2000,3,-3,6,-3,4,-22,4,0,2000,3,-3,6,-3,3,-24,3,0,2000,3,-3,6,-3,3
,-20,2,-2,3,0,2000,3,-3,6,-3,4,-19,7,0,2000,3,-3,6,-3,4,-20,7,0,2000,3,-3,6
,-4,4,-20,8,0,2000,3,-3,6,-4,6,-15,7,-1,5,0,2000,3,-3,6,-5,9,-7,10,-4,5,0
4430 DATA2000,4,-1,7,-6,25,-4,5,0,2000,12,-7,23,4,8,0,2000,11,-9,21,-4,19,
0,2000,-1,9,-11,19,-5,10,0,2000,-2,7,-14,15,-8,0,2000,-4,3,-20,6,-15,4,0,
1000
4500 REM SM H
4510 DATA3,-64,3,0,3,-64,3,0,78,0,78,0,78,0,78,0,78,0,3,-27,5,0,3,-29,
4,0,-33,4,0,-34,0,0,-35,4,0,-36,3,0,-37,3,0,-37,3,0,-36,4,0,-35,5,0,-33,6,0
,-27,12,0,-38,0,37,0,35,0,33,0,30,0,26,0,3,0,3,0,1000
4600 REM SM I
4610 DATA37,3,0,3,-33,4,0,3,-31,6,0,40,-13,4,0,40,-11,8,0,40,-10,10,0,40,-
10,10,0,40,-11,8,0,40,-13,4,0,3,0,3,0,1000
4700 REM SM J
4710 DATA8,4,0,0,-1,13,0,2000,-4,16,0,2000,-3,5,-2,10,0,2000,-2,4,-5,8,0,200
0,-1,4,-3,4,0,2000,4,0,2000,3,0,2000,4,0,2000,-1,4,-37,3,0,2000,-1,7,-34,3,0,2000,-2,43,-13,4,0,2000,-2,43,-11,8,0,2000,-3,42,-10,10,0,40,-10
,10,0,-2,38,-11,8,0
4720 DATA-8,32,-13,4,0,1000
4800 REM SM K
4810 DATA3,-64,3,0,3,-64,3,0,78,0,78,0,78,0,78,0,78,0,3,-12,4,0,3,-14,
4,0,-19,4,0,-19,6,0,-17,9,0,-15,13,0,-13,12,-1,4,0,-11,13,-3,4,0,-9,13,-7,4
,0,-7,13,-11,4,-2,3,0,3,-2,13,-14,4,-1,3,0,3,-1,12,-10,6,0,14,-22,4,0,12,-2
5,3,0,10,27,3,0
4820 DATA0,-29,3,0,6,-31,3,0,4,0,3,0,3,0,1000
4900 REM SM L
4910 DATA-67,3,0,3,-63,4,0,3,-62,5,0,78,0,78,0,78,0,78,0,78,0,3,0,3,0,3,0,
1000
5000 REM SM M
5010 DATA3,-34,3,0,-34,3,0,40,0,40,0,40,0,40,0,40,0,3,-30,4,0,3,-31,
4,0,-35,3,0,-36,3,0,-37,3,0,-37,3,0,-36,4,0,3,-32,5,0,3,-29,8,0,40,0,39,0,3
9,0,39,0,38,0,36,0
5020 DATA3,-30,4,0,3,-32,3,0,-36,3,0,-36,3,0,-37,3,0,-37,3,0,-36,4,0,-35,5,
0,-32,0,0,40,0,40,0,39,0,39,0,38,0,36,0,3,0,3,0,1000
5100 REM SM N
5110 DATA3,-34,3,0,3,-34,3,0,40,0,40,0,40,0,40,0,40,0,3,-30,4,0,3,-31,
4,0,-35,3,0,-36,3,0,-37,3,0,-37,3,0,-36,4,0,-35,5,0,-32,0,0,40,0,39,0,39,0,
39,0,38,0,36,0,3,0,3,0,1000
5200 REM SM O
5210 DATA-15,10,0,-11,10,0,-8,24,0,-6,28,0,-4,32,0,-3,34,0,-2,12,-12,12,0,-
1,8,-22,0,0,-1,6,-26,6,0,-1,4,-30,4,0,-3,34,0,3,-34,3,0
5220 DATA3,-34,3,0,4,-32,4,0,-1,4,-30,4,0,-1,6,-26,6,0,-1,8,-22,8,0,-2,12,-
12,12,0,-3,34,0,-4,32,0,-6,28,0,-8,24,0,-10,20,0,-15,10,0,1000
5300 REM SM P

```

Program continues

the size of those produced by the standard version. In line 19, I change to the 132-character-per-line mode. In line 43, I simulate printing at 12 lines per inch by printing a carriage return and line feed and then a half line feed reverse. If you have a 12 lines-per-inch mode or a method of doing half line feeds on your printer you should be able to run this version.

Customizing the Character Set

You can easily change letters or even replace a few characters with pictures just by changing or replacing the Data statements for that character. The number system *i* use works as follows: *positive numbers* print that many characters, and *negative numbers* print the absolute value number of spaces. For example, -10 prints ten spaces. Zero is the end of line indicator. It prints a carriage return and line feed. 2000 indicates a start at the left margin instead of indenting five spaces. Unless preceded by a 2000, all lines have five blank spaces in front of them. The 2000 code provides descenders on letters such as p and g. 1000 is the end of letter data indicator. The program will begin the next letter of the input string when it reaches a 1000.

For example, the string 10, -10,5,0,1000 prints ten characters, ten spaces, and five more characters all on the same line. The 1000 indicates the end of the data.

If you decide to type in the program listing, be sure the Data statements are exact, or you may end up with some rather odd-looking letters. Type in the Remark statements between letters as you go just in case you make a mistake or want to change something. The time you may save is well worth the time spent in typing them. Also, the very last letter before the double quote in line 10 is supposed to be a shift @, but it appears as a grave accent. ■

Ron Balewski has a degree in computer science from Penn State University. His hobbies include home computers, community theatre, amateur radio, and model railroading.

For TRS-80 Models I and III

Introducing the Lowest Cost Hard Disk System Ever . . Laredo's LS525.



\$1995*

5 million low cost bytes of on-line storage.

At \$1995.00 affordable hard disk storage is now within your reach.

The LS525 hard disk system is easier to use than your printer . . . just plug it in switch it on and your disk storage problems are over forever.

The LS525 gives you unheard-of speed and reliability. For starters we built a "mainframe like" controller that can detect disk surface defects and relocate the data to alternate tracks. Talking about speed the LS525 can access files 10 times faster than your floppy.

This coupled with proven "winchester" technology is what we mean by reliability and speed.

We also provide a user friendly TRSDOS compatible operating system in which all of your existing soft-

ware can run on. It provides features that can make the LS525 look like one big 5M byte drive or four small 1.25M drives or whatever you like.

The LS525 is a compact (less than one half cubic foot) "color-keyed" package that will fit perfectly next to your TRS-80. So if your tired of seeing "Disk Space Full". . . .

. . . there's no excuse.



Call toll free and order yours now.

(800) 538-5137

Inside California call (408) 980-1888.

* Model I or III host adapter \$250 & LDOS \$160 extra, specify when ordering.

(LDOS Includes hard disk driver and Formatter)

laredo systems inc.

. . .mass storage for personal computers.

Laredo Systems Inc. 2264 Calle De Luna, Santa Clara, California 95050

✓53 TRS-80 and TRSDOS are trademarks of Radio Shack a Tandy Co.

Program continued

8,-5,15,-30,15,0,-3,10,-44,10,0,-2,7,-52,7,0,-1,5,-50,5,0,3,-40,3,0,1000
7300 REM
7310 DATA3,-64,3,0,-1,5,-50,5,0,-2,7,-52,7,0,-3,10,-44,10,0,-5,15,-30,15,0,
-7,21,-14,21,0,-9,52,0,-12,46,0,-15,40,0,-18,34,0,-22,26,0,-24,18,0,1000
7400 REM
7410 DATA-3,4,-26,4,0,-1,0,-22,0,0,10,-20,10,0,10,-20,10,0,-1,0,-22,0,0,-3,
4,-26,4,0,1000
7500 REM
7510 DATA-26,4,-10,3,0,-24,7,-7,7,0,-23,9,-5,9,6,-23,9,-5,10,0,-24,0,-3,10,
0,-26,7,-3,9,0,-27,6,-2,7,0,-29,5,-1,6,0,-18,4,-0,4,-1,4,-9,4,0,-16,11,-5,2,
-1,2,-6,11,0,-15,40,0,-15,40,0,-16,11,-5,2,-1,2,-6,11,0,-18,4,-0,4,-1,4,-9
4,0,-28,6,-1,6,0
7520 DATA-26,7,-3,7,0,-25,8,-3,9,0,-23,10,-3,10,0,-22,10,-5,10,0,-22,10,-5,
9,0,-23,8,-7,7,0,-26,4,-10,3,0,1000
7600 REM
7610 DATA-25,10,0,-25,10,0,-25,10,0,-25,10,0,-25,10,0,-25,10,0,-25,10,0,-25,
10,0,-25,10,0,-25,10,0,-25,10,0,-25,10,0,-25,10,0,-25,10,0,-25,10,0,-25,10,
0,-25,10,0,-25,10,0,1000
7700 REM
7710 DATA-20,10,-10,10,0,-20,10,-10,10,0,-20,10,-10,10,0,-20,10,-10,10,0,-20,
10,-10,10,0,-20,10,-10,10,0,-20,10,-10,10,0,-20,10,-10,10,0,-20,10,-10,10,
0,-20,10,-10,10,0,-20,10,-10,10,0,-20,10,-10,10,0,-20,10,-10,10,0,-20,10,-
10,10,0
7720 DATA-20,10,-10,10,0,-20,10,-10,10,0,-20,10,-10,10,0,-20,10,-10,10,0,1000
7800 REM
7810 DATA-24,21,0,-10,32,0,-14,12,-10,10,0,-11,9,-29,7,0,-9,6,-37,6,0,-7,5,
-43,5,0,-5,4,-10,15,-15,5,0,-3,4,-14,27,-11,3,0,-2,4,-12,33,-10,5,0,-1,4,-1
2,36,-10,4,0,-1,3,-12,38,-10,4,0,3,-12,40,-10,4,0,3,-12,13,-15,12,-11,3,0,
7820 DATA3,-12,8,-26,6,-12,3,0,3,-12,5,-30,5,-12,3,0,3,-13,3,-32,4,-12,3,0,
-1,3,-12,3,-12,3,-13,3,0,-1,3,-14,3,-20,3,-14,3,0,-2,3,-7,43,-11,3,0,-3,3,-
5,44,-10,3,0,-4,3,-3,45,-9,4,0,-5,3,-2,45,-8,4,0,-6,1,-2,46,-7,4,0,-9,46,-5
5,0
7830 DATA-10,4,-44,5,0,-11,3,-41,6,0,-12,5,-33,9,0,-14,10,-15,16,0,-17,32,0
,-22,17,0,1000
7900 REM
7910 DATA2000,1,-12,4,-16,4,0,2000,-1,1,-9,0,-12,0,0,2000,-1,2,-7,10,-10,10
,0,2000,-2,4,-4,10,-10,10,0,2000,-4,15,-12,8,0,-1,13,-14,4,0,-4,0,0,1000
8000 REM
8010 DATA-30,10,0,-30,10,0,-30,10,0,-30,10,0,-30,10,0,-30,10,0,-30,10,0,-30,
10,0,-30,10,0,-15,40,0,-15,40,0,-15,40,0,-15,40,0,-15,40,0,-15,40,0,-30,10,
0,-30,10,0,-30,10,0,-30,10,0,-30,10,0,-30,10,0,-30,10,0,-30,10,0,-30,10,0,
1000
8100 REM
8110 DATA3,0,6,0,-3,6,0,-6,6,0,-9,6,0,-12,6,0,-15,6,0,-18,6,0,-21,6,0,-24,6
,0,-27,6,0,-30,6,0,-33,6,0,-36,6,0,-39,6,0,-42,6,0,-45,6,0,-48,6,0,-51,6,0,
-54,6,0,-57,6,0,-60,6,0,-63,6,0,-66,6,0,-69,6,0,1000
8200 REM
8210 DATA-53,0,0,-51,12,0,-50,10,-1,3,0,-50,10,-2,3,0,-51,0,-4,3,0,-53,4,-7
,3,0,-3,4,-50,3,0,-1,8,-57,3,0,10,-10,17,-28,5,0,10,-10,23,-21,6,0,-1,0,-23
,14,-16,7,0,-3,4,-29,15,-9,9,0,-39,29,0,-41,26,0,-43,23,0,-45,19,0,-47,15,0
,-50,0,0,1000
8300 REM
8310 DATA-15,4,-32,4,0,-16,4,-30,4,0,-17,4,-28,4,0,-10,4,-26,4,0,-18,5,-24,
5,0,-19,4,-24,4,0,-20,4,-22,4,0,-21,4,-20,4,0,-22,4,-10,4,0,-23,4,-16,4,0,-
23,4,-16,4,0,-24,4,-14,4,0,-25,4,-12,4,0,-26,4,-10,4,0,-27,4,-8,0,0,-27,5,-
6,5,0,-28,4,-6,4,0
8320 DATA-29,4,-4,4,0,-30,4,-2,4,0,-31,0,0,-31,0,0,-32,6,0,-33,4,0,-34,2,0,
1000
8400 REM
8410 DATA-34,2,0,-33,4,0,-32,6,0,-31,0,0,-31,0,0,-30,4,-2,4,0,-29,4,-4,4,0,
-28,4,-6,4,0,-27,5,-6,5,0,-27,4,-8,4,0,-26,4,-10,4,0,-25,4,-12,4,0,-24,4,-1
4,4,0,-23,4,-16,4,0,-23,4,-16,4,0,-22,4,-18,4,0,-21,4,-20,4,0,-20,4,-22,4,0
,-19,4,-24,4,0
8420 DATA-18,5,-24,5,0,-10,4,-26,4,0,-17,4,-28,4,0,-16,4,-30,4,0,-15,4,-32,
4,0,1000
8500 REM
8510 DATA-25,20,0,-20,30,0,-16,30,0,-13,40,0,-11,40,0,-9,52,0,-7,22,-12,22,
0,-6,16,-26,16,0,-5,13,-34,13,0,-4,11,-40,11,0,-3,9,-46,9,0,-2,0,-50,0,0,-1
7,-54,7,0,-1,5,-58,5,0,5,-60,5,0,5,-60,5,0,4,-62,4,0,2000,-1,78,0
8520 DATA2000,-1,78,0,2000,-1,78,0,4,-62,4,0,-62,4,0,-1,4,-6
0,4,0,-1,4,-60,4,0,-1,5,-58,5,0,-2,5,-56,5,0,-3,3,-34,3,0,-4,6
,-50,6,0,-6,5,-48,5,0,-7,6,-44,6,0,-9,6,-46,6,0,-11,6,-36,6,0,-13,7,-30,13,
0,-15,5,-30,13,0,1000

Program Listing 2. Super Banner II

1 REM ***** SUPER BANNER I *****
3 REM BY RON BALEWSKI
10 CLEAR500:DEFINTA-Z:DIMMG\$(10),SC\$(10),PS(100,2):L\$="ABCDEFGHIJKLMNPOQRS
TUVWXYZ 1234567890abcdefghijklmnopqrstuvwxyz.,!@#\$%&'()*~+<>{}"
12 NL=85
14 NF=1
15 CLS:PRINT"JUST A MINUTE, PLEASE.":PRINT:PRINT:POKE=1TONL:PS(K,1)=PEEK(16640)
639):PS(K,2)=PEEK(16640)
17 READLP:IFLP=100THENNEXTKELSEGOTO17
19 LPRINTCHR\$(27);CHR\$(20):POKE=1TONL:PRINT"INPUT MESSAGE ";K:INPUTMG\$(K):
IFMG\$(K)<>"END"THENSC\$(K)="":INPUT"PRINT CHARACTER (ENTER FOR CORRESPONDING
)":SC\$(K):PRINT
21 IFMG\$(K)="END"THENK=K-1:GOTO25
23 NEXTK
25 NH=K
27 FORKA=1TONH
28 CLS:PRINT"START MESSAGE";KA;" ==> ";MG\$(KA):PRINT
29 FORKB=1TOLEN(MG\$(KA)):PRINTMID\$(MG\$(KA),KB,1);
31 LI\$=MID\$(MG\$(KA),KB,1)
33 FORKT=1TOLEN(LI\$):IFLI\$=MID\$(LI\$,KT,1)THENGOTO3ELSENEXTKT:PRINT"ERROR I
N MESSAGE";MG\$(KA):STOP
35 POKE=16639,PS(KT,1):POKE=16640,PS(KT,2):READLP
37 IFLP=10000THENGOTO47
38 IFNF=1THENNF=0:IFLP>2000THENLPRINTSTRINGS(30," ");ELSELPRINTSTRINGS(25
," ");READLP
39 IFLP>0THENIFSC\$(KA)="":THENLPRINTSTRINGS(LP,LI\$):ELSELPRINTSTRINGS(LP,SC\$
(KA)):
41 IFLP<0THENLPRINTSTRINGS(ABS(LP)," ");
43 IFLP<0THENLPRINTCHR\$(13);CHR\$(27);CHR\$(30):NF=1
45 READLP:GOTO37
47 LPRINT":LPRINT":NF=1:NEXTKB:FORKC=1TONH:LPRINT":NEXTK
49 NEXTKA
51 CLS:PRINT"END OF PRINT.":PRINT:PRINT:GOTO19

TECO MONITORS

RATED BEST BUY BY THE COMPUTER SHOPPER

NOW AN EVEN BETTER BUY

- B & W MONITOR HIRES 119.95
- GREEN PHOSPHOR HIRES 129.95
- GREEN PHOSPHOR ULTRARES 144.95
- TRS-80 CABLE 5.00
- 5 1/4" DISK DRIVES WITH PS & CASE 289.95

FROM

THE MAINE SOFTWARE LIBRARY
P.O. BOX 197
STANDISH, ME 04084

CHECK, MO. COD (20% DEPOSIT ON COD)
ADD \$10 SHIPPING FOR MONITOR. \$6 FOR DRIVES

LNW-80-OWNERS

WE HAVE SOME TERRIFIC IDEAS AND PRODUCTS TO MAKE THIS GREAT COMPUTER EVEN BETTER. WRITE TO US FOR PACK-AGE BEFORE YOU BUILD.

198

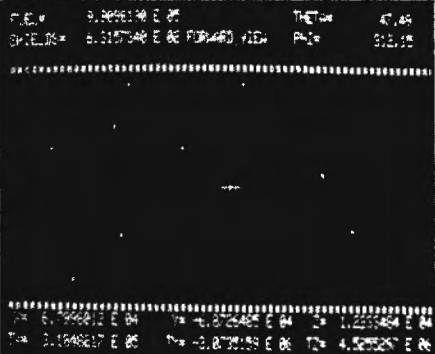

-80 SPACE RAIDERS

Starship Simulator and Combat Game

This is the most realistic combat space simulation available for any computer system anywhere! Operator is placed in a rapidly moving ship looking out through a window into the depths of space. Thousands of stars appear in the distance and part toward the screen edges as the ship flashes past. Forward and aft views available at any time. Accurate celestial navigation using both XYZ and spherical Coordinates! Comment from Aug '81 *80 Microcomputing*: "May be the ultimate Star Trek type game and, possibly, the most complex micro-computer game ever attempted!" Fast action graphics never stop!

Now available for Model III!
\$24.95 (MasterCard, VISA, check, etc.) includes shipping. COD OK

Specify Model I or III, Level 2 16K

Bosen Electronics
445 E. 800 N.
Spanish Fork, UT 84660
(801)-798-9553

294

Aerocomp's Proven Best-By Test! The "DDC"

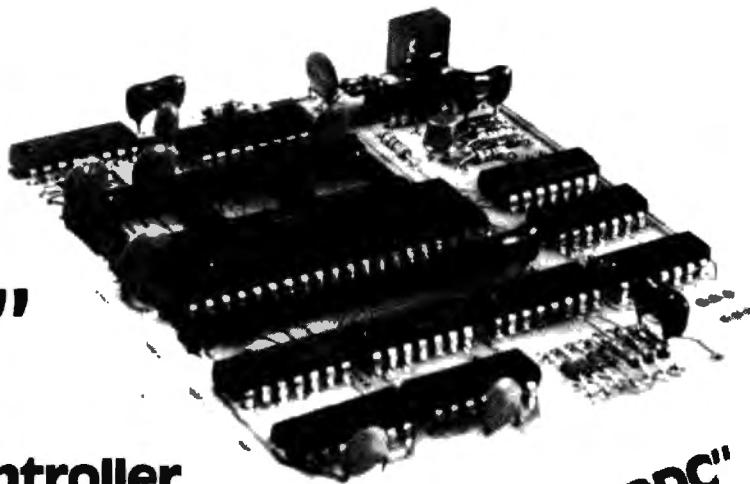

Double Density Controller

★ Technical Superiority

At last! A double density controller for Model I with HIGHER PROBABILITY OF DATA RECOVERY THAN WITH ANY OTHER DOUBLE DENSITY CONTROLLER ON THE MARKET TODAY! The "DDC" from Aerocomp. No need to worry about the problems that keep cropping up on existing products. AEROCOMP's new design phase lock loop data separator has a wider capture window than the digital types currently being used. The finest resolution available with digital circuitry is 17.5 cycles per bit. The "DDC" analog circuit allows infinitely variable tuning. Attack and settling times are optimum. The units presently on the market use a write precompensation tolerance is extremely wide - in the order of ± 100 ns. The bottomline is state of the art reliability!

★ Test Proven

Tests were conducted on AEROCOMP'S "DDC", Percom's TRS80 Model I, Level 2, 48 K with Tandy's Radio Shack TRS80 Model I, Level 2, 48 K with Tandy's (Siemens Model 82). Diskette was Memorex 3401. The minimum performance under adverse conditions. The expansion interface. The test consisted of formatting 40 tracks on the diskette. The pattern was chosen because it is recommended as the best pattern to attempt was then made to read each sector on the diskette. The test was run ten times with each double density controller and the data averaged. Test results are shown in the table.

★ Features

TRS80 Model I owners who are ready for reliable double density operation will get (1) 80% more storage per diskette, (2) single and double density data separation with far fewer disk I/O errors, (3) single density compatibility and (4) simple plug-in installation. Compatible with all existing double density software.

★ Value

\$149.95 for the BEST double density controller on the market.

\$189.95 for "DDC" complete with DOSPLUS 3.3D

\$239.95 for "DDC" complete with LDOS

Data Separators

The advances that make the "DDC" great are incorporated in the new AEROCOMP Single Density and Double Density Data Separator ("DDS").

★ Has your original manufacturer left you holding the bag?

If you already own a Percom "Doubler A", "Doubler II" or LNW "LNDOUBLER", the AEROCOMP "DDS" will make it right. Look at the test results:

MFR. & PRODUCT	SECTORS LOCKED OUT	
	WITHOUT "DDS"	WITH "DDS"
PERCOM "DOUBLER II"	18	1
PERCOM "DOUBLER A"	250	0
LNW "LNDOUBLER"	202	0

Note: Same test procedures as "DDC".
* Trademark of Percom Data Co.
** Trademark of LNW
*** Trademark of Tandy Corporation

**Plugs directly into your existing
Double Density Controller.**

★ "DDS" \$49.95
(Use 1791 chip from your DD Controller)

★ "DDS" with disk controller
chip included \$79.95

★ Disk controller
chip \$34.95

(Shipping \$2.00 Cont. US - see opposite page for details)

Happy DDS customer writes . . .

I don't often write letters such as this, but I feel I should in this case . . . I am surprised and pleased with your DDS. It is not often a product is better than one expects. This (these) test (s) used a Percom Doubler "A" (Test without DDS installed showed many errors) (With DDS) not one error!!! After ten (10) tests of formatting and verifying and zeroing NOT ONE FAILURE OR LOCK OUT. Great!!!

Phil Gnadt
Kansas City, Kansas

Phil Gnadt

**See opposite
page**



TRS 80*

DISK DRIVES

40 & 80 TRACK

as low as **\$299.95**

ORDER TODAY!

- ★ 40-Track Drive. \$299.95
- ★ 80-Track Drive. \$409.95
- ★ 40-Track "FLIPPY" Drive. . . . \$329.95
- ★ 80-Track "FLIPPY" Drive. . . . \$419.95
- ★ 40-Track Dual-Head Drive. . . \$419.95
- ★ 80-Track Dual-Head Drive. . . \$569.95

All above drives are complete with silver enclosure, power supply and external drive cable connection. 115 VAC 50/60 Hz 230 VAC 50/60 Hz available on special order.

- ★ 40-Track Bare Drive. \$259.95
- ★ 80-Track Bare Drive. \$359.95
- ★ 40-Track "FLIPPY" Bare Drive \$279.95
- ★ 80-Track "FLIPPY" Bare Drive \$369.95

★ SPECIAL PACKAGES★

STARTER A. \$339.95
40-Track Drive, 2-drive cable, TRSDOS 2.3 Disk & Manual, Freight & Ins.

STARTER B. \$369.95
40-Track "FLIPPY" Drive, cable, TRSDOS 2.3 Disk & Manual, Freight & Ins.

COMBO C. \$465.00
40-Track "FLIPPY" Drive, 2-drive cable, LDOS, Freight & Ins.

COMBO D. \$559.00
80-Track "FLIPPY" Drive, 2-drive cable, LDOS, Freight & Ins.

COMBO E. \$709.00
Two 40-Track "FLIPPY" Drives, 4-Drive cable, TRSDOS 2.3 Disk & Manual, Freight & Ins.

COMBO F. \$989.00
Two 80-Track "FLIPPY" Drives, 4-drive LDOS Ins.

COMBO G. \$889.00
Two 40-Track Dual-Head Drives, cable, TRSDOS 2.3 Disk & Manual, Freight & Ins.

COMBO H. \$1289.00
Two 80-Track Dual-Head Drives, cable, LDOS, Freight & INS.

DOSPLUS 3.3 or NEWDOS / 80, 2.0 available with any package.

Add \$5.00 per drive for shipping & handling (Cont. US)

FREE TRIAL OFFER

Order your AEROCOMP Disk Drive and use it with your system for up to 14 days. If you are not satisfied for ANY REASON (except misuse or improper handling), return it, packed in the original shipping container, for a full refund. (Hardware only. Special packages will be prorated). We have complete confidence in our products and we know you will be satisfied! **ORDER TODAY!!!**

WARRANTY

We offer you a 120 day unconditional warranty on parts and labor against any defect in materials and workmanship. In the event service, for any reason, becomes necessary, our service department is fast, friendly and cooperative.

100% TESTED

AEROCOMP Disk Drives are completely assembled at the factory and ready to plug in when you receive them. Each drive is 100% bench tested prior to shipment. We even enclose a copy of the test checklist, signed by the test technician, with every drive. AEROCOMP MEANS RELIABILITY!!

ORDER NOW!!

To order by mail, specify Model Number(s) of Drive, cable, etc. (above), enclose check, money order, VISA or MASTERCHARGE card number and expiration date, or request C.O.D. shipment. Texas residents add 5% sales tax. Add \$5.00 per drive for shipping & handling (Cont. US). Please allow 2 weeks for personal checks to clear our bank. No personal checks will be accepted on C.O.D. shipments-cash, money orders or certified checks only. You will receive a card showing the exact C.O.D. amount before your shipment arrives. Be sure to include your name and shipping address. You will be notified of the scheduled shipping date. Your bank credit card will NOT be charged until the day we ship!!

DRIVE CABLES

2-DRIVE. \$24.95
4-DRIVE. \$34.95

WRITE AEROCOMP TODAY FOR MORE VALUES !!!

CALL TOLL FREE FOR FAST SERVICE (800) 824-7888, OPERATOR 24

FOR VISA / MASTERCHARGE / C.O.D. ORDERS

California dial (800) 852-7777, Operator 24. Alaska and Hawaii dial (800) 824-7919, Operator 24.

TOLL FREE LINES WILL ACCEPT ORDERS ONLY!

For Applications and Technical information, call (214) 337-4346 or drop us a card.

Dealers inquiries invited

AEROCOMP
Redbird Airport, Bldg. 8
P.O. Box 24829
Dallas, TX 75224

✓82

NEW LOW PRICES

Thanks to you our sales volume has allowed us to cut costs and we're passing the savings along. We offer the best disk drive value in the market place. Reliability, features and cost tough to beat. We deliver...and we stand behind our products. AEROCOMP is the only manufacturer to offer FREE TRIAL! Buy AEROCOMP drives today. You deserve the best.

BEST FEATURES

- ★ Fast 5 ms. track-track access time.
- ★ Operates single or double density.
- ★ "FLIPPY" feature for lower media cost (40-1 & 80-1).
- ★ Head load solenoid.
- ★ Disk ejector.
- ★ Easy entry door.
- ★ **NEW** EXTERNAL DRIVE CABLE CONNECTION. (no longer need to remove the cover to hook up cable)

EPSON MX80 PRINTERS \$469.00

TRS80 Cable (I & III) \$29.95
APPLE Cable & Interface. . \$105.00
RS232 Interface. \$69.95
Ribbon Cartridge, Black. . . \$13.95
Add \$6.00 shipping (Cont. U.S.) does not include cable.

MX80 F/T

All the features of MX80 plus Friction Feed. Shipping & cables as above.

\$579.00



Become an interstellar truck driver.

Space Chase

*Charles E. Gillen
American Embassy, Seoul
APO San Francisco 96301*

Here's a 16K Level II game, for the fumble-fingered, that places few demands on the intellect. As you guide a robot cargo ship through the hazards of space, no less than 26 sub-routines are invoked to tickle your ears and eyes. The game has no instructions or complicated strategies to master, and is suitable for all ages.

Get Ready for Fun!

Start by connecting your keyboard to an amplifier, using the plug that normally goes to the cassette Aux jack. If you do not have an amplifier, put a small radio nearby and you will still hear many of the program's sound effects.

Your goal is to guide three robot-piloted freighters to Terra while dodging the hazards of space: pirates called "space-jackers," encounters with greedy aliens, friendly space tankers, exploding engines, space vortices, robot problems,

loose plasma-bombs, space holes, asteroid showers, signals from humans in distress, drifting space derelicts and UFOs.

The job is not difficult; your screen relays the freighter's visual sensors, and you have a short list of commands to control the flight. These commands allow you to go at impulse or warp speed, or risk a hyper-space jump. You occasionally must recharge the ship's crystal power (XTAL) banks and plug a fresh battery (BATT) into the robot-pilot so he can continue accepting your orders.

The ship's computers will tell you when to issue a particular order. If you fail to pay attention, you must suffer the consequences. You can summon the on-board computer for a status readout, and also fire missiles at your pursuers. If things get too tough, press the Quit key to abort and start over.

Shortly after launch, you must race the space-jackers to the safety of Terra. Your screen will constantly tell you the number of parsecs (DX:) left to go, as well as warning messages. Reports from the robot-pilot and messages from your employer, Cargo Command, are also visible.

Do not worry if you lose a few ships—the robots are expendable and your shift will end if you

can land three successfully. Then you can spend all your money. The bonus earned on each successful flight is put in your bank account, though you cannot bank bonus money earned during a flight ending in space disaster.

Many things can happen in space, but the game is biased toward non-violent and humanitarian action. Failure to respond to an S.O.S. call may entail sad consequences, and trying to fight off aliens is rarely successful. Your missiles are sometimes effective against the space-jackers, but wasting them will reduce your bonus.

Most of the game's action involves various random elements chained together in either a random or cause/effect relationship. Certain strategies may facilitate success. You can key in your name as the game starts, or hit Enter and let Cadet Fred Fumble represent you. Each good landing earns you a promotion.

The two tables of variables (Tables 1 and 2) explain the mechanics of the program so you can modify it. The listing is long, but leaves enough room in a 16K system for the TC-8 high-speed tape software, or some other utility. All the subroutines are in the final block of lines beginning at 2000, and you can

delete all REMs without crashing the program.

Many features and interrelations may not be apparent in your first try, so spend a few sessions with the game before you tinker with it. You might add a game-end situation based on bonus money earned, rather than the number of successful landings. If your version is better than this Space Chase, I would like to hear about it.

This program POKes the machine language sound generator into the free reserved RAM space; it does not use the VARPTR method of keeping the routine in a string. See my Missiles from Mars game (*80 Microcomputing*, January 1982) for guidance on moving the sound routine to the top of 16K memory. ■

Charles E. Gillen is 48 years old and has spent most of the last 20 years in Asia. He does all his programming on a simple 16K Model I.

The Key Box

**Basic Level II
Model I
16K RAM**

- A(#) Locations to print asteroids
- AJ Number of space-jackers hit by asteroids
- B Number of batteries left
- BB Plasma-bomb flag
- BP Print location for Battery Low message
- C Multi-purpose counter
- CH Character used to paint screen
- D Multi-purpose counter
- F Tons of cargo
- G Colony to Terra distance
- HB Amount of bonus earned
- HT Total in bank account
- J Distance done by space-jacker
- JP Jump flag
- K Number of space-jackers killed
- L Number of ships lost
- M Number of missiles left
- O Number of orders left in battery
- P Number of parsecs moved since launch
- PA Print location for Alien graphic
- PD Print location for "DX:" distance
- PJ Print location for space-jacker graphic
- PM Print location for message
- Q Increment in vortex sound
- R Number of robot-cargo ship
- RH Number of humans saved per rescue
- RS Number of humans saved per voyage
- S Multi-purpose counter and USR call
- SR Counter in star-printing loop
- ST Counter to give head start on jacker
- T Alien tractor beam flag
- TB Print location of tractor beam graphic
- TK Print location of space tanker
- U Print location of UFO
- V Temporarily holds G variable
- W Warp flag
- WI Number of ships landed successfully
- X Number of XTALS charged
- XP Print location of "XTAL LOW" message

Table 1

- AL\$ Alien graphic
- AM\$(1) "GROK?" spoken by aliens
- AM\$(2) "BARF!"
- AM\$(3) "FRED?"
- B\$ "BATT LOW"
- BY\$ "BATTERY"
- CC\$ "CARGO COMMAND"
- DS Derelict ship graphic
- DNS Moves cursor to print alien
- DT\$ "DERELICT"
- EJ\$ Erases space-jacker graphic
- F\$ Prints one line of screen frame
- J1\$ Intercepting object graphic
- J2\$ Space-jacker graphic
- M\$ Menu of orders
- M1\$ "MESSAGE:"
- M2\$ "REPORT:"
- M4\$ "ORDER:"
- M5\$ "WARNING:"
- M7\$ "QUERY:"
- N\$ Player name else "FRED FUMBLE"
- NY\$ "NOT READY"
- PB\$ "PLASMA-BOMB"
- RK\$(0) "CADET"
- RK\$(1) "CAPTAIN"
- RK\$(2) "COLONEL"
- RP\$ "ROBOT-PILOT"
- RY\$ "READY"
- S\$ Three spaces
- S1\$ "SPACE-JACKER"
- TS Tanker graphic
- XS "XTAL LOW"
- YS INKEY\$ loops

Table 2

Program Listing

```

10 REM ***** CHARLES E. GILLEN
20 REM ** SPACE CHASE **
30 REM ***** AMERICAN EMBASSY, SEOUL
40 REM ***** APO SAN FRANCISCO 96301
46 REM V.1140CT81
100 CLS:A=3:FORB=1TO16:PRINT@A,STRINGS(34,"*");A=A+62:NEXT:A=B:FORB=1TO16
:PRINT@A,STRINGS(33,">");A=A+66:NEXT:PRINT@472,"SPACE CHASE";
110 RANDOM:CLEAR400:DEFINTA-Z:DEFDBLE R=1:F$=CHR$(191)+CHR$(254)+CHR$(191):
M1$="MESSAGE:";M2$="REPORT:";M4$="ORDER:";M5$="WARNING:";M7$="QUERY:"
:IFM=515:BP=131:XP=161:J1$=STRINGS(2,140):RY$="READY:";NY$="NOT READY:"
120 FORC=16446TO16474:READD:POKEC,D:NEXT:POKE16526,62:POKE16527,64:DATA285,
127,18,62,1,14,0,237,91,61,64,69,47,230,3,179,211,255,13,40,4,16,246,24,242
:37,32,241,281
130 GOSUB2198:SJ$="SPACE-JACKER":RP$="ROBOT-PILOT":CC$="CARGO COMMAND":BY$=
"BATTERY":PB$="PLASMA-BOMB":DT$="DERELICT":PD=565:DIMRK$(2):RK$(0)="CADET"
:RK$(1)="CAPTAIN":RK$(2)="COLONEL"
140 M$="BATT / XTAL / COMP / WARP / JUMP / FIRE / QUIET":EJ$=CHR$(200
)+CHR$(26)+STRINGS(8,8)+CHR$(200):PJ=276:DIMA(8):T$="-----<+J1$>+-----":D$
=J1$+M$+XJ1$S$+CHR$(195)
150 DNS=CHR$(26)+STRINGS(5,8):AL$=CHR$(183)+CHR$(164)+*"+CHR$(152)+CHR$(18
7)+DN$+CHR$(152)+CHR$(159)+CHR$(191)+CHR$(175)+CHR$(164)+DN$+CHR$(130)+CHR$
(139)+CHR$(188)+CHR$(135)+CHR$(129):AM$(1)="GROK?":AM$(2)="BARF!":AM$(3)="F
RED?"
160 B$="BATT LOW":X$="XTAL LOW":J2$=" "+CHR$(144)+*"+CHR$(164)+CHR$(176)+C
HR$(132)+*"+CHR$(144)+CHR$(26)+STRINGS(8,8)+CHR$(136)+STRINGS(2,131)+CHR$(
143)+CHR$(159)+CHR$(135)+CHR$(131)+CHR$(137)
170 CLS:GOSUB2049:CB=37:GOSUB2070:PRINT@336,"INTER-COLONIAL "CC$":GOSUB
2019:PRINT:PRINTS$"WILL HIRE YOU AS A ROBOT-CARGO CONTROLLER IF YOU ENTER":
INPUT"YOUR NAME HERE:":N$:GOSUB2100:IFLEN(N$)=0THENN$="FRED FUMBLE"
180 PRINT@0,"":GOSUB2048:CH=47:GOSUB2070:PRINT@M,M2$:PRINT@707,"ROBOT-CA
RGO *R*LAUNCHED BY COLONY ZED-LWXX.":PRINT:PRINTS$"SWITCHING TO ONBOARD VI
EWSCREEN...":GOSUB2028:PRINT@963,"PLEASE TAKE CONTROL NOW.":GOSUB2090:GOSU
B2010
190 M=5:J=0:P=0:T=0:O=5:B=7:X=7:ST=0:F=100:G=100+RND(100):HB=B:W=1:JP=1:AJ=
0:HS=0:K=0:CH=32:GOSUB2070
200 REM TOP OF ACTION LOOP
210 PRINT@PJ,EJ$:P=202+RND(40):GOSUB2050:IFB=1THENPRINT@PM,M5$:GOSUB2010
:PRINT"ONLY 1 "R$S" BY$":LEFT,"":GOSUB2090:GOSUB2020
220 IFB=1THENIFRND(20)>1THEN240ELSEGOSUB2010:PRINT@P$"REPORTS "PB$" TICKI
NG...":GOSUB2028:CLS:FORB=1TO3000:NEXT:GOSUB2010:PRINT"SHIP "R1$OS
T FROM SCREEN.":GOSUB2020:L=L+1:BB=0:GOTO1260
230 IFBTHENIFRND(5)=1THENGOSUB2010:PRINT@P$"R*STILL TRYING TO TAKE THE "PB
$" APART...":GOSUB2020
240 IFO<1THENPRINT@PM,M3$:PRINT@BP,B$:GOSUB2010:PRINTBY$"FAILING...REGR.
E.T...":GOSUB2090:GOSUB2020:GOTO202ELSEIFO=1THENPRINT@BP,B$:
250 ST=ST+1:IFSTHENGOSUB2020:GOTO600
260 IFST<6THEN20ELSEJ+J+RND(9):IFJ<PTHEN200
270 GOSUB2060:PRINT@PM,M3$:GOSUB2010:PRINT"SHIP OVERTAKEN BY "BJ$":PRINT
@PJ,J2$:GOSUB2100:GOSUB2220:GOTO1210
280 IFST<6THEN310ELSEIFST<6THENPRINT@PM,M2$:GOSUB2010:PRINT"SENSORS DETECT
OBJECT ON INTERCEPT ORBIT.":GOSUB2020:GOTO2090ELSEPRINT@PM,M2$:GOSUB2010:P
RINTS$S$"SIGHTED "P-J" PARSECS BACK.":GOTO300
290 PRINT@PJ,J1$:GOTO310
300 PRINT@PJ,J2$:GOSUB2100:GOSUB2020:IFRND(2)=1THENPRINT@PJ,EJ$:
310 PRINT@PJ,J3$:PRINT@CD,"DX:"G-P":GOSUB2010:PRINT@PM,M4$:PRINT@707,M$:
PRINT@835,"CONTROLLER IN CHARGE.":RK$(W1)$:PRINT@963,"BANK ACCOUNT:"BT
:SS$S$S$"BONUS THIS FLIGHT:"HB:
320 REM INKEY$ CMD LOOP
330 Y$=INKEY$:PRINT@PM,M7$:STRINGS(2,143):IFX<2THENPRINT@XP,X$:GOSUB2100
340 IFO<1THENPRINT@BP,B$:GOSUB2170
350 PRINT@PM,M7$:S$:IFO<6THEN100ELSEIFY$="B"THEN400ELSEIFY$=" "THEN490ELSEI
FY$="H"THEN530ELSEIFY$="M"THEN580ELSEIFY$="C"THEN600ELSEIFY$="J"THEN450ELSE
IFY$="P"THEN390ELSEIFY$="Q"THENGOSUB2010:GOTO1260
360 S=USR(250+RND(5)*10):GOTO330
370 REM ORDERS
380 REM FIRE
390 O=0-1:IFM=1THENM=0:GOTO400ELSEIFM=0THEN430ELSEPRINT@PJ,J2$:M=M-1:PRINT
@PM,M2$:GOSUB2010:PRINT"FI R I N G":GOSUB2000:IFRND(10)<3THEN410ELSE420
400 IFP=J<18ANDH>0THEN410ELSE420
410 GOSUB2000:GOSUB2000:PRINT@PJ,EJ$:GOSUB2010:PRINT"ATTACKER DESTROYED.":
PRINTS$CC$"WILL PAY BOUNTY OF 2,000 SOLS.":GOSUB2020:J=0:ST=0:HB=HB+2000:K
=K+1:GOTO210
420 GOSUB2010:PRINT"REGRET FIRE NOT EFFECTIVE.":PRINT:PRINTS$"MISSILES LEFT
":M:GOSUB2020:GOTO210
430 PRINT@PM,M5$:GOSUB2010:PRINT"MISSILE TUBES EMPTY.":PRINT:GOSUB2220:GOTO210
440 REM JUMP
450 O=0-1:IFBTHENGOSUB2010:PRINTCC$":PRINT:GOSUB2090:PRINTS$"JUMP ORDER
COUNTERMANDED.":PRINTS$"ONLY A MADMAN WOULD JUMP WITH A "PB$" ABOARD.":GOSU
B2020:GOTO210
460 IFJPORX<3THENGOSUB2010:PRINT"JUMP "NYS:GOSUB2220:GOTO210ELSEGOSUB2010:P
RINT"JUMP TO HYPERSPACE.":JP=1:X=X-3:CB=165:GOSUB2070:GOSUB2210:GOSUB2010:I
FRND(3)=1THEN470ELSEPRINT"JUMP FAILED.":P=0:J=0:ST=0:GOSUB2220:CH=32:GOSUB2
070:GOTO210
470 HB=HB+500:PRINT"JUMP SUCCESSFUL.":GOSUB2020:GOSUB2230:CH=32:GOSUB2070:P
=P+20+RND(30):PRINT@PD,"DX:"G-P":GOTO210
480 REM IMPULSE
490 HB=HB+50:JP=0:W=0:O=0-1:X=X-1:PRINT@PM,M2$:GOSUB2010:PRINT"IMPULSE DRI
VE ENGAGED.":GOSUB2240:IFX<1THEN810
500 IFX<2THENPRINT@PM,M5$:PRINT@XP,X$:GOSUB2020
510 P=P-RND(10):PRINT@PD,"DX:"G-P":IFRND(9)<4THEN660ELSE210
520 REM WARP
530 O=0-1:IFWTHENPRINT@PM,M1$:GOSUB2010:PRINT"WARP "NYS:GOSUB2220:GOTO210
540 IFX=2=>0OR<1THENGOSUB2010:PRINT"INSUFFICIENT XTALS TO WARP.":GOSUB2200
:GOTO210ELSEIFX=3=>0THENGOSUB2010:PRINT"USING LAST XTALS TO WARP.":GOSUB2220
550 HB=HB+100:GOSUB2010:PRINT"WARP DRIVE ENERGIZED...":PRINT@PJ,EJ$:GOSUB
2120:W=1:X=X-3:IFX<2THENPRINT@PM,M5$:PRINT@XP,X$:
560 P=P+5+2*RND(10):PRINT@PD,"DX:"G-P":IFRND(9)<6THEN660ELSE210
570 REM XTAL
580 O=0-1:PRINT@181,CHR$(200):PRINT@PM,M2$:GOSUB2010:PRINT"XTAL BANKS REC
HARGED.":GOSUB2020:X=7:GOTO210
590 REM COMPUTER
600 O=0-1:PRINT@PM,M2$:PRINT@707,"":PRINTTAB(20)O"MORE ORDERS ON THIS "BY
$".:S$$S$:PRINTTAB(20)X"POWER XTALS CHARGED.":PRINTTAB(20)B"SPARE BATTERIES.
":PRINTTAB(20)M"MISSILES.":GOSUB2020:PRINTTAB(23)"WARP ":IFWTHENPRINTNY$:E
LSEPRINTRY$:
610 PRINTS$$S$"JUMP ":IFJPTBENPRINTNY$:ELSEPRINTRY$:
620 GOSUB2020:GOTO210
630 REM BATTERIES
640 PRINT@BP,CHR$(200):IFB<1THEN1210ELSEB=B-1:O=5:PRINT@PM,M2$:GOSUB2010:
PRINT"NEW "BY$" INSTALLED...B"LEFT.":PRINT:PRINTS$RP$"CAN ACCEPT "O"MORE
ORDERS.":GOSUB2020:GOTO210
650 REM TAKE A CHANCE
660 ORND(20)GOTO600,1100,910,930,910,800,600,970,860,930,1100,970,810,600,
860,790,930,840,790,970

```

Program continues

COTTAGE SOFTWARE

PACKER Machine language program that edits all or part of your Basic program to run faster, save memory, or ease editing. The 5 options include UNPACK—unpacks multiple statement lines into single statements maintaining logic, inserts spaces and renumbers lines. SHORT—deletes unnecessary words, spaces, and REM statements. PACK—packs lines into maximum multiple statement lines, including all branches. MOVE—moves line or blocks of lines to any new location on program. On 2 cassettes for 16K, 32K, & 48K

For TRS-80 Mod I or III Level II or Disk Basic ... \$29.95
SYSTEM TAPE DUPLICATOR. Copy your SYSTEM format tapes. Includes verify routines. The Model III version allows use of both 500 and 1500 baud cassettes speeds. For TRS-80 Model I or III Level II ... \$19.95

CASSETTE LABEL MAKER. A mini word processor to print cassette labels on a line printer. Includes 50 peel- and-stick labels on tractor feed paper.

For TR-80 Model I of III Level II & Printer ... \$17.95
PRINT TO LPRINT TO PRINT Edits your Basic program in seconds to change all Prints to LPrints (except Print@ or Print#) or LPrints to Prints. Saved edited version.

For TR-80 Model I or III Level II ... \$12.95

FAST SORT ROUTINES for use with Radio Shack's Accounts Receivable, Inventory Control I, and Disk Mailing List Systems for Model I Level II Sorts in SECONDS! You'll be amazed at the time they can save. Supplied on data diskette with complete instructions.

FAST SORT for Accounts Receivable ... \$19.95

FAST SORT for Inventory Control I ... \$19.95

FAST SORT for Disk Mailing List (specify data diskette of cassette for 1 drive system) ... \$14.95

ALL THREE ROUTINES ... \$44.95

Prices subject to change without notice. Call or write for a complete catalog. Dealer inquires invited. VISA and MasterCard accepted. Foreign order in US currency only. Kansas residents add 3% sales tax.

On-line catalog in Wichita FORUM.80. 316-682-2113

Or call our 24 hour phone (316) 683-4811 or write

COTTAGE SOFTWARE
 614 N HARDING
 WICHITA, KANSAS 67208

TRS-80™ is a trademark of Tandy Corporation

Program continued

```

678 REM ALIENS
688 PRINT@PJ,EJ$;TB=115:FORC=1T09:PRINT@TB,/////";S=USR(256+TB):TB=TB+5
9:NEXT:PRINT@PM,M3$;GOSUB2010:PRINT"ALIEN TRACTOR BEAM HOLDING SHIP.";GOSU
B2190
699 J=J+RND(10);IFJ>PTHEEN020
700 GOSUB2250:PRINT@PM,M4$;GOSUB2010:PRINT"ALIENS DEMAND 10 PERCENT OF CAR
GO.";PRINT@S$;"CARGO NOW AT F"TONG.";PRINT@S$;"FIGHT OR NEGOTIATE ?";IFST>6TBEN
PRINT@S$;P=J"PARSECS BEHIND.
710 Y$=INKEY$;IFX$="F"THEN730ELSEIFY$="N"THEN760ELSEGOSUB2130:GOTO710
720 REM FIGHT
730 IFRND(10)<7THEN740ELSECH=32:GOSUB2070;GOSUB2050:PRINT@PM,M2$;GOSUB2010
:PRINT"SHIP HAS ESCAPED ALIEN TRACTORS.";GOSUB2020;T=0:HB=HB+1000:GOTO210
740 GOSUB2250;GOSUB2230:PRINT@PM,M3$;GOSUB2250:GOSUB2010:PRINT"SHIP BEING
TORN APART BY ALIENS.";GOSUB2020:GOSUB2250:GOSUB2250:GOSUB2230:GOTO210
750 REM DEAL
760 F=F-(F/10);IFRND(10)>4THEN770ELSECH=32:GOSUB2070;GOSUB2050:PRINT@PM,M2$
:PRINT@PD,"DK:"G-P;GOSUB2010:PRINT"SHIP RELEASED. ALIENS FRIENDLY.";PRINT
S$;"CARGO LEFT:"F"TONS.";X=X+3;N=0:GOSUB2020;T=0:GOTO210
770 PRINT@PM,M2$;GOSUB2010:PRINT"NEGOTIATIONS STALLED. ALIENS UNFRIENDLY."
:GOSUB2020:GOSUB2250:T=1:GOTO210
780 REM TANKER
790 PRINT@PM,M2$;PRINT@PJ,EJ$;PRINT@XP,CHR$(200);TK=RND(0)*64+15+RND(30)
:PRINT@TK,T$;GOSUB2010:PRINT"PASSED SPACE TANKER *RND(13)-- ALL SYSTEMS
REPLENISHED.";GOSUB2020:PRINT@TK,CHR$(204);O=5;B=7;X=7;M=5;W=0:GOTO210
800 REM ENGINE
810 IFS<4THEN210ELSEGOSUB2230:CH=191:GOSUB2070:PRINT@PM,M2$;GOSUB2010:PRI
NT"ENGINES OVERLOADED.
THEY BLEW UP.
SORRY...";GOSUB2020:CH=32:GOSUB2070:GOSUB2050
820 PRINT@PM,M3$;GOSUB2010:PRINT@S$;"CLOSING IN FAST.";PRINT@PJ,J2$;GOSUB
2260:GOTO210
830 REM VORTEX
840 CH=64:GOSUB2070;V=G:PRINT@PM,M3$;GOSUB2010:PRINT"SPACE VORTEX
X";GOSUB2030:PRINT@PM,M2$;GOSUB2010:PRINT"PARSECS OFF COURSE:"G-V:GOSUB20
20:CH=32:GOSUB2070;GOSUB2050:GOTO210
850 REM ROBOT TROUBLE
860 GOSUB2010:PRINT@S$;"GOSUB2090:PRINT@SRP$;R;ONRND(5)GOTO870,880,890,8
70,890
870 PRINT"JUST ATE A 'BYS' WITHOUT AN ORDER.";PRINT@S$;"SCHEDULE HIM FOR REPA
IR IF HE LANDS.";GOSUB2020;B=B-1:GOTO210
880 PRINT"HAS BLOWN A FUZE.";PRINT@S$;"RETURN TO COLONY FOR A NEW SHIP.";GOSU
B2020:GOTO130
890 PRINT"FOUND A 'PBS' IN 'BYS' LOCKER.";PRINT@S$;"RE IS TRYING TO DIS
MANTLE IT.";GOSUB2090;GOSUB2020;BB=1:GOTO210
900 REM SPACE HOLE
910 CH=32:GOSUB2070;GOSUB2010:PRINT@S$;"PRINT@S$;"SHIP #R"LOST CONTA
CT. MUST BE IN A SPACE HOLE.";PORD=1703500:NEXT:GOSUB2050:GOSUB2050:IFRND(2
)-1THENP=P+10:GOTO210ELSEP=P-10:GOTO210
920 REM ASTEROIDS
930 FORC=1T02:FORB=0T010:A(S)=64*RND(9)+11+RND(40);PRINT@A(S),CHR$(130+RND(
60));GOSUB2110:NEXT:FORB=0T010:PRINT@A(S)," ";NEXT:NEXT:J=J+1:P=P-RND(3):
PRINT@PD,"DK:"G-P;PRINT@PM,M5$;GOSUB2010:PRINT"SHIP SPEED REDUCED BY ASTE
ROID SHOWER.";GOSUB2020
940 IFS>5ANDRND(3)=1THENGOSUB2080:PRINT@PJ,EJ$;J=0:GOSUB2010:PRINT@S$;"HI
T AN ASTEROID.";AJ=AJ+1:GOSUB2020:IFRND(2)=1THEN970
950 GOTO210
960 REM SOS
970 PRINT@PM,M3$;GOSUB2010:PRINT"DISTRESS SIGNAL NOTED ON ULTRAWAVE.";PRIN
T@S$;"RESPOND OR IGNORE ?";GOSUB2140
980 Y$=INKEY$;LFY$="R"THEN990ELSEIFY$="I"THEN1000ELSEGOSUB2140:GOTO980
990 ONRND(7)GOTO1020,1040,1050,1040,1070,1010,1030
1000 PRINT@PM,M2$;GOSUB2010:HB=HB-100:PRINT"HAVE RESUMED COURSE FOR TERRA.
";PRINT@S$;"SPACE LAW FINE OF 100 SOLS DEDUCTED FROM BONUS.";GOSUB2020:IFRND(
5)>1THEN210ELSE0"AND BLOW UP
1010 IFAJTHENPRINT@PM,M1$;GOSUB2010:PRINT@S$;"GOSUB2090:PRINT@S$;"SOURCE O
F S.O.S. SIGNAL IS A 'SJS'.";PRINT@S$;"DO NOT RESPOND.";GOSUB2020:GOTO210
1020 PRINT@PM,M5$;GOSUB2010:PRINT"SIGNAL WAS A ROAK.";PRINT@S$;"OTHER SHIP L
OOKS LIKE A PIRATE.";GOSUB2020:GOTO210
1030 PRINT@PM,M2$;GOSUB2010:PRINT"SENSORS FOUND NOTHING. RESUMING COURSE."
:PRINT@S$;"COLLECT 500 SOLS REWARD FROM SPACERS' RELIEF FUND.";HB=HB+500;GOSU
B2020:GOTO210
1040 PRINT@PM,M2$;GOSUB2010:PRINT"THE S.O.S. FADED AWAY. NOTHING SEEN.";GO
SUB2020:GOTO210
1050 PRINT@PM,M2$;GOSUB2010:RH=1+RND(3);HS=HS+RH:PRINT"FOUND"RH"HUMANS IN
RESCUE CAPSULE.";PRINT@S$;"THEY OFFER"RH*897"SOLS FOR PASSAGE HOME.";HB=HB+RH
*897:GOSUB2020:GOSUB2020
1060 IFSBTHENIFRND(3)=1THENBB=0:PRINT@S$;"A HUMAN SHUT OFF OFF 'PBS' JUST IN
TIME.";GOSUB2020:GOTO210ELSE210
1070 PRINT@PJ,EJ$;PRINT@PJ,DS;PRINT@PM,M7$;GOSUB2010:PRINT"SENSORS SHOW
'DTS' SHIP. NO SIGN OF LIFE.";PRINT@S$;"SALVAGE OR DESTROY ?
1080 Y$=INKEY$;IFY$="S"THEN1090ELSEIFY$="D"THEN1100ELSEGOSUB2130:GOTO1080
1090 PRINT@PM,M2$;GOSUB2010:ONRND(3)GOTO1100,1110,1120
1100 PRINT"NOTHING OF VALUE FOUND. WILL RESUME COURSE.";GOSUB2020:GOTO210
1110 PRINT"FOUND WEAPONS AND USEFUL CARGO. NOW TAKING ABOARD.";N=N+3;P=P+RN
D(10)*(F/10);GOSUB2020:GOTO210
1120 PRINT@S$;"CRAWLING WITH ALIENS...THEY HAVE INVADED SHIP.";GOSUB2190:IF
HS>4THENPRINT@S$;"THE"HS"HUMAN PASSENGERS OVERCAME THEM.";CH=32:GOSUB2070;GOS
UB2050:GOSUB2020:GOTO210ELSESET=1:GOTO700
1130 IFM<1THEN40ELSEM=M-1:PRINT@PM,M5$;GOSUB2010:PRINT"READY TO FIRE...";
GOSUB2020:GOSUB2080:ONRND(3)GOTO1140,1150,1160
1140 PRINT@PJ,EJ$;PRINT@PM,M2$;GOSUB2010:PRINT"THE 'DT$' DESTROYED. RESUM
ING COURSE.";GOSUB2020:GOTO210
1150 GOSUB2230:ST=5:CH=191:GOSUB2070:GOSUB2010:PRINT"THE 'DT$' EXPLC...DAMA
GE TO ...";GOSUB2020:CH=32:GOSUB2070:GOSUB2050:GOTO810
1160 HB=HB+2000;X=X+1:PRINT@PJ,J2$;GOSUB2020:GOSUB2080:PRINT@PM,M3$;GOSUB
2010:PRINT@S$;"HE WAS HIDING BEHIND 'DT$'.";PRINT@S$;"HE WAS DESTROYED ALSO.";PR
INT@S$;"SHIP #R"NOW JUMPING TO TERRA TERMINUS.";GOSUB2120:GOSUB2120:P=G:GOTO
1200
1170 REM UFO
1180 PRINT@PJ,EJ$;U=72+RND(25);FORC=1T09:PRINT@U,J1$"";GOSUB2180:PRINT@U
," ";GOSUB2170;U=U+62+2*RND(3);NEXT:PRINT@PM,M7$;GOSUB2010:PRINT"WHAT TH
E BELL WAS THAT ?";GOSUB2020:IFRND(3)>1THEN210ELSEB=1:PRINT@PM,M5$;GOSUB20
10
1190 PRINT@S$;"GOSUB2090:PRINT@S$;"THAT UFO ZAPPED THE SPARE BATTERIES.";GO
SUB2020:GOTO210
1200 REM BRICKBATS
1210 L=L+1:GOSUB2010:PRINT"FROM INTER-COLONY 'CC$' HQ";GOSUB2090:PRINT@771
,"";ONRND(4)GOTO1220,1230,1240,1250
1220 PRINT"ROBOT-CARGO #R"LOST. WHOSE SIDE ARE YOU ON ?";GOTO1310
1230 PRINT"PLEASED 'RR$(WI)N$' LOST ONLY'L'SHIPS SO FAR.";GOTO1310
1240 PRINT@S$;"#R"REPORTED 'RR$(WI)N$'S 'A 'STRINGS$(8,143)";GOTO1310
1250 PRINT@S$;"RADIO SAYS 'RR$(WI)N$' WAS BRIBED.";GOTO1310
1260 PRINT@S$;"SAYS 'N$' NEEDS MORE PRACTICE.";IFY$="Q"THENPRINT@S$;"
ACCOUNT FINAL TOTAL:'HB+HT"SOLS.";GOTO1310ELSE1310
1270 REM SUCCESS
1280 PRINT@PD,"DK: 000";GOSUB2020:PRINT@PM,M2$;GOSUB2010:PRINT"SHIP #R"L

```

Program continues

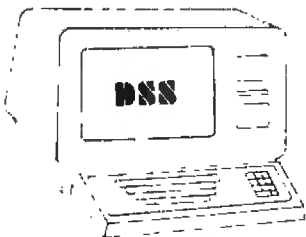

Decision Science Software

OPERATIONS RESEARCH	STATISTICAL PACKAGE	ECOPAK
LP	REGRESS	FUTURE VALUE
DYNAM	MULTI-REG	ANNUITY
NETWORK	MATRIX	EFFECTIVE
PERT	FUTURE	DEPR
EQ	FORECASTING	SALVAGE
LOT SIZING	MARKOV	NET PRESENT
FORECASTING	QUEUE	VALUE
DECIDE	SIMULATION	DCF RATE OF
MRP		RETURN
TRANSPORTATION		

TRS-80 model I and III

APPLE II

16K-1 Disk Drive

minimum system requirement

\$49.95 to 249.95

for information

DECISION SCIENCE SOFTWARE
 865 Castle Ridge Road
 Austin, Texas 78746
 (512) 327-1463



*trademark of the Tandy Corp

394

ECHOTM SPEECH SYNTHESIZERS



CONVERSATION PIECES

Let your computer speak up with an ECHO speech synthesizer. Besides the popular ECHO II (Apple), we now have three new models which give you quality speech synthesis at reasonable prices starting at \$225. Our new products include the ECHO 80 (TRS-80 models I & III), ECHO 100 (S-100), and the ECHO GP (general purpose, serial/parallel).

ECHO speech synthesizers use LPC synthesis pioneered by Texas Instruments. Our SPEAKEASY[™] phoneme system provides unlimited vocabulary while using a minimum of memory. The TEXTALKER[™] speech generator, standard with all ECHOs, incorporates nearly 400 grammatical rules to translate normal English text to speech automatically. Simple commands allow you to select from:

- 63 different pitch levels
- Words spoken monotonically or with intonation
- Fast or slow speech output
- Entire words pronounced or spelled letter by letter
- Different volumes
- Spoken punctuation if desired

The applications for the ECHO speech synthesizers are virtually unlimited, ranging from business and education to games to aiding the handicapped.

For more information or a demonstration see your dealer or contact:



Street Electronics Corporation
3152 E. La Palma Avenue, Suite D
Anaheim, CA 92806 Tel: 714-632-9950

WOBOS I

W. O. B. O. S.

Basic Operating System

Who needs it? Everyone who writes or uses programs in BASIC. For Tape systems it's like having a DOS without the hardware! For Disk systems it provides the structure that DOS doesn't! When you **LOAD** this magnificent System you get over 30 powerful programs, routines and subroutines at your direct command or from a 9 choice Menu that can very easily be doubled and customized to your needs. Designed to be used as "stock" for ALL BASIC programs.
Simply add your program to it!

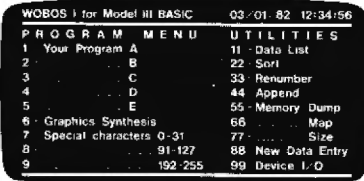

- * It will add multifrequency SOUND to your TRS-80
- * It will standardize your writing and save you many hours of debugging and rewriting utility functions.
- * It will help you structure YOUR OWN programs.

"Once you've used it, you'll never write another program without it!"

Model I		Model III	
LEVEL II	DISK	MODEL III	DISK
CC1022A	CD1032A	CC1021B	CD1031A

ON QUALITY CASSETTE & MANUAL

ORDER PHONE **(503) 649-4826** VISA MasterCard ONLY \$35

SEND CHECK, MONEY ORDER OR NUMBER AND EXPIRATION DATE OF YOUR CREDIT CARD TO:

6640 SW 173 AVENUE, BEAVERTON, OREGON 97007

Dedicated to Excellence since 1976

TRIS-80 is a TM of TANDY CORP.

Program continued

```

ANDED WITH "B" TONS OF CARGO INTACT.":HB=B*200+M*999+P*99+HB:HT=HT+HB:PRINTSS
" Bonus OF "B" SOLS PAID. YOUR ACCOUNT TOTALS "HT" SOLS.":WI=WI+1
1299 PRINTSS "YOU BLASTED "K;SJS" S.,";:IFAJ>0 THEN PRINT "ASTEROIDS GOT "AJELSEP
RINT"
1300 PRINTSS "YOU SAVED "HS" HUMANS.":IFWI>2 THEN PRINTSS "YOU LANDED 3 OUT OF "R"
SHIPS. . . YOUR SHIFT IS OVER.":GOSUB220:GOSUB2299:PRINTSS "CONGRATULATIONS, G
O SPEND YOUR "HT" SOLS.":;GOSUB2210:GOSUB2199:GOSUB2239:CLS:CLEAR50:END
1310 PRINT@963;"YOU LANDED "WI" SUCCESSFULLY AND LOBT "L" SO FAR.":
1320 CH=32:GOSUB2070:POHC=1T010:GOSUB2050:NEXT:PRINT@344;" < SPACEBAR > ":
GOSUB2B30:GOSUB2B10:PRINT "LAUNCH ANOTHER ROBOT-CARGO ?":GOSUB2090:CH=32:GOS
UB2B70
1330 Y$=INKEY$:IFY$="Y" THEN R+1:GOTOLB ELSE IF Y$="N" THEN GOSUB2B10:GOTOL34BE
LSE=USR(300):GOSUB2650:GOTOL330
1340 PRINT " H I C K E N ";:GOSUB2100:IFINKEY$="" THEN S=USR(300):GOTOL340
ELSE CLG:CLAEAR50:END
2000 REM SOUND/GRAPHIC ROUTINES
2010 PRINT@704;"":FORC=1T05:PRINTCHR$(255):;NEXT:PRINT@707;"":RETURN'CLR
TEXT
2020 FORC=1T020:S=USR(500):FORD=1T070:NEXT:NEXT:RETURN'DELAY
2030 IF INKEY$<"*" THEN S=USR(256+Q):Q=Q+3:G=Q+1:HB=HB-1:PRINT@PD;"DX:"G-P;:G
OTO2030 ELSE RETURN'VORTEX
2040 PRINT$STRING$(64,176)F$F$F$F$F$F$F$F$F$STRING$(64,143):PRINT@24;" SPAC
E CHASE *";RETURN'FRAME
2050 FORS=1T03:S=USR(268):PRINT@64*RNA(9)+11*RNA(40),"";:IFRNA(2)=1 THEN PRI
NT" *";ELSE PRINT" *";:STARS
2060 NEXT:RETURN
2070 S=577:FORD=1T09:PRINT$;STRING$(62,CH):;S=64:NEXT:RETURN'VARIABLE SC
REEN
2080 FORC=1T03:S=USR(333):PRINT@PJ-1+RNA(4)," *";:S=USR(3000):PRINT@PJ,EJ$;:
S=USR(333):NEXT:PRINT@PJ,EJ$;:RETURN'FIRE
2090 FORC=1T05:S=USR(2575):S=USR(2560):FORD=1T010:NEXT:NEXT:RETURN'BEEPER
2100 FORC=5T01$STEP-1:S=USR(3333/C):NEXT:RETURN'BLEEP
2110 SE=USR(1378+RNA(100)):RETURN'ASTEROID SOUND
2120 FORC=200T0200$STEP100:S=USR(C):NEXT:FORC=1T03+RNA(9):S=USR(2500-C):GOS
UB2050:NEXT:RETURN'WARP SOUND
2130 S=USR(333):FORD=1T0200:NEXT:RETURN'INKEY$ TICK
2140 FORC=1T03:GOSUB2170:NEXT:FORC=1T03:GOSUB2180:NEXT:FORC=1T03:GOSUB2170:
NEXT:GOSUB2160:RETURN'SOS
2150 FORD=1T025:NEXT:RETURN'CW DELAY
2160 FORD=1T0100:NEXT:RETURN'CW SPACE
2170 S=USR(1299):GOSUB2150:RETURN'DIT
2180 S=USR(12819):GOSUB2150:RETURN'DAB
2190 S=USR(17949):S=USR(17947):S=USR(17953):S=USR(17963):S=USR(23079):RETUR
N'ALIEN LONG THEME
2200 S=USR(7709):S=USR(7707):S=USR(7713):S=USR(7723):S=USR(10279):RETURN'SH
ORT THEME
2210 FORC=60T0520$STEP-1:S=USR(C):NEXT:FORC=52T0600:S=USR(C):NEXT:RETURN'J
UMP
2220 FORC=1T05:S=USR(13055):FORD=1T050:NEXT:NEXT:RETURN'NOT READY
2230 FORC=1T03:OUT255,15:S=USR(2756):OUT255,PEEK(16445):S=USR(2700):NEXT:RE
TURN'SCREEN SHAKE
2240 FORC=39T0260$STEP-10:S=USR(C):NEXT:FORC=26T0360:S=USR(C):NEXT:RETURN'
IMPULSE SOUND
2250 PA=456+RNA(6)*6:PRINT@PA,ALS;:FORC=1T03:GOSUB2130:PRINT@PA+65,CHR$(143
);:PRINT@PA+67,CHR$(143):;PRINT@PA-128,AM$(RNA(3)):;GOSUB2170:PRINT@PA+65,C
RR$(159):;PRINT@PA+67,CHR$(175):;S=USR(25*25+4):NEXT:RETURN'ALIENS
2260 FORC=1T05:S=USR(25675+C*30):GOSUB2150:NEXT:C=USR(25855):RETURN'JACKER
    
```

THE ALTERNATE SOURCE

Programmer's Journal

We could tell you that it's the best available, BUT WE'D RATHER PROVE IT.

Supporting TRS-80 Models I and III only...

If you're the type of person whose satisfaction is NOT from loading a computer program, BUT from knowing what makes it tick, what makes it work and how to improve it, then you are invited to accept a guaranteed, no risk, money back offer. The Alternate Source Programmer's Journal would like YOU to critique it's contents. A thinking, creative mind like yours is not content to simply accept things the way they are. Just now we are learning to effectively utilize the power inherent in that little gray box of yours. You're looking for newer, faster, and better ways to utilize this power. Thousands of computerists rely on TAS to provide this information; we GUARANTEE their satisfaction. Consider a NO RISK trial subscription to-day -- if you're unhappy with the first issue, drop us a note and we'll refund your money. We think you'll like it, though, with our easy-to-understand features and dozens of enlightening articles on programming the computer you love. In over two years of publication, only TWO persons have requested their money back. Discover why -- try an issue of The Alternate Source Programmer's Journal today! Twelve issues are \$24. Published eight times annually.

(Subscription rates for outside USA differ; please inquire. Thanks.)

Special for 80 Micro readers!

DDSD/CMD allows automatic density recognition of both single and double density disks when using NEW DOS/80 Version 2.0, eliminating previous headaches with paramaters. Just execute it when booting the system, and forget it! Regularly \$19.95, just \$10 when subscribing to TAS. Limited offer.

- () I'll try 12 issues of TAS; enclosed is \$24.
- () I'll subscribe and take DDSD; \$34 total.
- () I'll take just DDSD; \$19.95 plus \$3 P&H.

Name: _____
 Address: _____
 City: _____
 State, Zip: _____

The Alternate Source
 704 North Pennsylvania Avenue
 Lansing, Michigan 48906

Ph. 517-482-TASO
 Micronet: 70150.255
 Source: TCH565

"DOS RANDOM ACCESS & BASIC FILE HANDLING"

the HOW TO, SHOW & TELL, STEP by STEP book. Written for TRS-80 and all computers using Microsoft basic. The breakthrough book for non-programmers... businessmen and professionals who want to solve in house problems by writing your own customized program... and the hobbyist with the desire to get beyond the cassette and into disk data storage and file manipulation. "DOS Random Access & File Handling" is the plain speaking, easy to read 150 page book for learning HOW TO WRITE SPECIAL PROGRAMS for inventories, mailing lists, work schedules, record keeping and more. Your acquaintance with Level I and Level II basic and this self-instruction tutorial will assure quick progress.

DSC Publishing
2 Dogwood Drive
PO Box 769
Danbury, CT 06810

Phone Order
(203) 748-3231



Yes, I want to expand my programming knowledge. I have Model I or III () Model II ()

Please send me a copy of "DOS Random Access & File Handling" for \$29.50 & \$1.50 shipping Model II \$1.50 extra.

Also send me the compatible program disk for 28.50 + 1.50 shipping. Model II 32.50 + 1.50

Overseas add 8.00 per book and disk airmail.

Name _____

Address _____

City _____

State _____ Zip _____

Master Charge VISA

Expiration Date _____

Card # _____

Check Money Order

COD (2.00 extra)

Signature _____

"Dealer Inquiries Invited" Phone Orders (203) 748-3231
CT. orders add 7.5% sales tax.

Looking for a Spelling Checker?
Get more than just a spelling checker — get

HEXSPELL 2™

the EVERYTHING checker

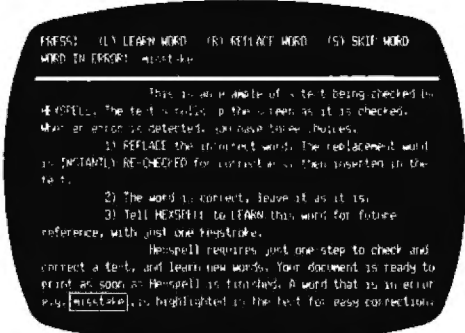

Hexagon Systems is proud to announce another first in text checking — an everything checker. Hexspell 2 checks not only dictionary words, but learns and checks codes, formulae and numbers which are so essential in many commercial and technical documents. With Hexspell 2 you define what characters make up a word, then teach Hexspell the new "words" it needs to check your text. This advanced system builds on the unique features of the original Hexspell (the first TRS-80 spelling checker). Hexspell 2 features a one-step interactive process, a word list that adapts itself to your word usage, a 25,000 word initial word list and more than three years of research and experience.

Hexspell 2 upgrade for registered owners of Hexspell Vers. 1 — \$35 from Hexagon Systems or your nearest dealer.

Hexspell requires a TRS-80 Mod I or Mod III with 2 drives and 48K

US \$99



P.O. Box 397, Station A
Vancouver, B.C. Canada V6C 2N2
Telephone (604) 682-7646
Micronet 70235,1376

✓ 46

PRODUCTS FOR YOUR RADIO SHACK

NEW!

COLOR COMPUTER

MICROTEXT COMMUNICATIONS VIA YOUR MODEM!

Now you can use your printer with your modem! Your computer can be an intelligent printing terminal. Talk to timeshare services or to other personal computers; print simultaneously through a second printer port; and re-display text stored in memory. Download text to Basic programs; dump to a cassette tape, or printer, or both. Microtext can be used with any printer or no printer at all. It features user-configurable duplex/parity for special applications, and can send any ASCII character. You'll find many uses for this general purpose module! Available in ROMPACK, ready-to-use, for \$59.95.

SOFTWARE DEVELOPMENT SYSTEM

The Micro Works Software Development System (SDS80C) is a complete 6809 editor, assembler and monitor package contained in one Color Computer program pack! Vastly superior to RAM-based assemblers/editors, the SDS80C is non-volatile, meaning that if your application program bombs, it can't destroy your editor/assembler. Plus it leaves almost all of 16K or 32K RAM free for your program. Since all three programs, editor, assembler and monitor are co-resident, we eliminate tedious program loading when going back and forth from editing to assembly and debugging!

The powerful screen-oriented Editor features finds, changes, moves, copies and much more. All keys have convenient auto repeat (typamatic), and since no line numbers are required, the full width of the screen may be used to generate well commented code.

The Assembler features all of the following: complete 6809 instruction set; complete 6800 set supported for cross-assembly; conditional assembly; local labels; assembly to cassette tape or to memory; listing to screen or printer; and mnemonic error codes instead of numbers.

The versatile ABUG monitor is a compact version of CBUG, tailored for debugging programs generated by the Assembler and Editor. It features examine/change of memory or registers, cassette load and save, breakpoints and more. SDS80C Price: \$89.95

GAMES

Star Blaster — Blast your way through an asteroid field in this action-packed Hi-Res graphics game! Available in ROMPACK; requires 16K. Price: \$39.95
Pac Attack — Try your hand at this challenging game by Computerware, with fantastic graphics, sound and action! Cassette requires 16K. Price: \$24.95
Berserk — Have fun zapping robots with this Hi-Res game by Mark Data Products. Cassette requires 16K. Price: \$24.95
Adventure — *Black Sanctum* and *Calixto Island* by Mark Data Products. Each cassette requires 16K. Price: \$19.95 each.

ROMLESS PAK I — is an empty program pack capable of holding two 2716 or 2732 EPROMs, allowing you up to 8K of program! The PC board inside comes with sockets installed, ready to go with the addition of your custom EPROMs. Price: \$24.95

2-PASS DISASSEMBLER — with documentation package. 16K; cassette. 80C Disassembler Price: \$49.95

CBUG — Machine language monitor. CBUG Cassette Price: \$29.95
CBUG ON 2716 EPROM: Can plug into Romless Pak I. CBUG ROM Price: \$39.95

PARALLEL PRINTER INTERFACE — serial to parallel converter allows use of all standard parallel printers. P180C Price: \$69.95

Assembly Language Programming, by Lance Leventhal. Price: \$16.95

MEMORY UPGRADE KITS: 4-16K Kit Price \$39.95. 16-32K (requires soldering experience) Price: \$39.95

PARTS & SERVICES: SAMS, 6809Es, RAMs, PIAs. Call for prices.

THE MICRO WORKS

✓125



GOOD STUFF!

WE SHIP FROM STOCK!

Master Charge/Visa and COD Accepted

P.O. BOX 1110 DEL MAR, CA 92014 714-942-2400



The Key Box

Basic Level II
Model I or III
16K RAM
Optional line printer

Using a TRS-80 to digest golf scores.

Fore! Scorekeeper

Rodger Wells
1008 Kehoe Drive
St. Charles, IL 60174

During a medium-sized golf tournament, much frustration and confusion surrounds the scorekeeper . . . especially during the last few hours of the game! Many tournament scores are computed using the popular "Callaway Handicap" system. This system, while perhaps giving every player a fair chance to compete, gets very confusing.

The Callaway System computes your net score by deducting from your gross score the scores of some certain number of holes. The number of holes to subtract is based on your total (gross) score. If you are a "scratch" golfer, you get no handicap, but should you shoot 130, for example, you can subtract the highest six holes. In addition, after you subtract the appropriate number of holes, another adjustment ranging from -2 to +2 applies to your handicap. Generally you determine the number of holes to subtract and the adjustment by referring to a table.

However, a few subtle rules complicate the matter further. No more than twice the par score

Rodger Wells has been developing application programs for work and fun for about 10 years. He is an employee of AT&T company.

for any hole may be deducted. Since the par score for a hole frequently differs for men and women you must consider the player's sex. Finally, the system specifies that you cannot deduct the scores of either of the last two holes played. (A player can take advantage of the handicap system by shooting a certain score on his last holes.) In a tournament golfers often start on both the "front" (hole 1) and the "back" (hole 10) courses, therefore you must consider which holes he played last.

Using Callaway manually is complex. The announcements of the winners are frequently delayed several hours after the last foursome has come in off the course. Tracking possible winners throughout the game is virtually impossible to handle manually.

To solve such a problem (and to create a conversation piece at the nineteenth hole) you can pack your TRS-80 out to the course to keep score. With a 16K machine and the Program Listing you can calculate the net scores for up to 200 golfers and keep track of the current standings.

To initiate the program you must first load the par scores that apply to the course. The program then asks whether guests are eligible to compete for prizes in your game. (If you are having a club or company game, this is often not permitted.) The program then asks you the number and the names of the units in competition. This

could be departments, lodges, teams, committees, and so on that the players represent.

After this initial loading, you are ready to input the individual player's scores. First, the program asks you how many players are in the group. This is usually four. Frequently, however, a group will lose a player they had planned on. If there are not four in the group, the scores will not be counted in the four-somes competition.

Next, you must enter a number to identify the group. I use the original tee-off time, for example, 0902 for 9:02 AM. If there are two groups, I use 0902.1 and 0902.2 for front and back course respectively. You must then specify whether the group started on the front (hole 1) or the back (hole 10) course.

Now you must enter individual data for the players. First, input the name for player one. The program will truncate the name to the first ten characters input to conserve space. Now specify which unit (department, and so on) this person represents. Next, input the player's sex by answering M or F.

Then enter the individual hole scores for holes 1-9. You always enter these scores first regard-

less of which holes were played first. Enter all nine scores on one line separated by commas. When you press Enter, the computer will display the gross score for the front nine. Check this with the scorecard. You must resolve any differences as either a keyboard error or a golfer error. Follow this with the scores for the back nine, and the program will ask you whether to continue or to reenter the scores.

When you continue, the program will calculate the player's net score and he will know immediately if he is in the running for any prizes. Anytime the "NAME?" prompt is on the screen, you can get a status of the low gross winners, low net winners, low foursomes, hole averages and more . . . to keep the conversation lively in the clubhouse during the long afternoon!

You can attach an optional line printer to give each golfer a "receipt" of his calculations. The first few lines of the program make up a machine language routine that will allow you to print the screen to a line printer by pressing the space bar and the shift key together. If you want to use this feature, answer Y to the question regarding the printer. ■

Program Listing

```
10 DATA 33,175,127,34,22,64,201,0,0
20 DATA 58,128,56,254,1,194,227,3,58,64,56,254,128,194,227,3,245,197,213,22
9,33,0,60,22,16,6,64,78,126,254,32,32,20,197,229,195,218,127,126,254,32,32,
8
30 DATA 35,16,248,241,193,195,234,127,225,193,205,141,5,35,16,224,14,32,6,2
```

Program continues

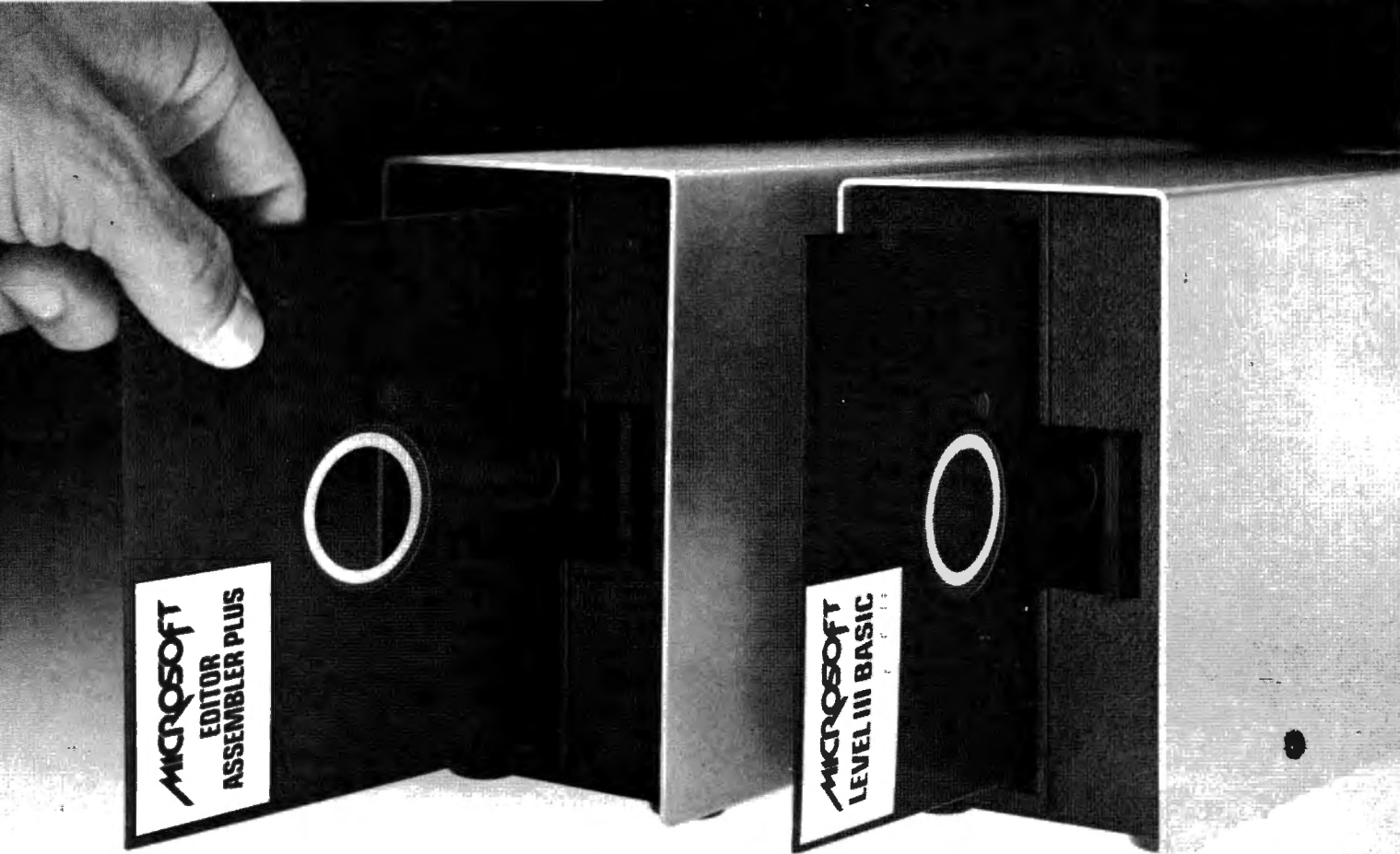

More powerful programming tools for the TRS-80™. Now on disk.

Better results. Microsoft's Level III BASIC and Editor/Assembler-Plus are programming tools that help you write complex programs in less time, with less effort and utilizing less memory. Better programs. No matter what your programming skill. And for the first time these tools are available on disk.

Editor/Assembler-Plus. A powerful editing, assembly and debugging tool with many sophisticated features that make writing TRS-80 assembly language programs easier, faster and more efficient.

- Full disk capabilities.
- Assembly directly into memory. No need to save object code then reload for execution.
- Macro capability that allows you to define macros for commonly used sequences of instructions.
- Conditional assembly that allows you to generate more than one version of a program.
- Eight breakpoints at a time for program debugging.
- The INCLUDE statement that allows you to call additional disk files for assembly.
- Other features include extensive operators, automatic origin, symbol table printout, quash command, hex, decimal and octal constants, single step-through instructions in memory, five type-out modes, four type-in radices, plus extensive edit commands.

A more powerful BASIC. With Level III BASIC, you get power to perform tasks in BASIC that used to require assembly language. Plus, new ease-of-use features for your TRS-80.

- Advanced graphics. Develop charts, graphs, even animation in Level III BASIC. Draw a line, an outline box or

a solid box by specifying just two points. Then save and recall it with BASIC commands.

- MENU. One command that allows you to construct an entire menu.
- CHAIN and COMMON commands allow you to call another program and pass variables to it.
- Powerful editing commands such as COPY/TRANSFER, FIND and CHANGE.
- DUMP command that makes debugging easier
- Time-limit response. New INPUT # LEN and LINE INPUT # LEN commands allow you to set a time limit on response.
- RS-232 output from BASIC. With a single command.
- More. Level III gives you automatic line numbering, 26 user-definable single stroke instructions, and more.

Disk or cassette. Disk versions of Level III and Editor/Assembler-Plus are brand new. Cassette versions are also available with many of the same capabilities.

Talk to your Microsoft™ dealer. Ask for a demonstration of two of the most powerful tools you can get for your TRS-80: Level III BASIC and Editor/Assembler-Plus. On disk or cassette. From Microsoft.

TRS 80 is a trademark of Radio Shack, a division of Tandy Corporation
Microsoft is a trademark of Microsoft, Inc
Microsoft Consumer Products is a division of Microsoft, Inc

282

MICROSOFT

CONSUMER PRODUCTS

10700 Northrup Way, Bellevue, WA 98004. (206) 828-8080

Program continued

```
.205,141,5,14,13,16,249,21,194,200,127,225,209,193,241,195,227,3
40 CLEAR2500
50 CLS
60 PRINT#405,"CALLOWAY GOLF TOURNAMENT"
70 PRINT#474,"COPYRIGHT 1979"
80 PRINT#539,"RODGER WELLS"
90 DIM P(18,2),S(18),T(18)
100 DIM M(11),MS(11),D(8,5,2),DS(8,5),LN(11,2),LNS(11)
110 DIM TL(21),G(21),F(21),TS(21),HT(18),FF(11,2)
120 FORK=1TO18:M(X)=200:LN(X,1)=200:FF(X,2)=899:NEXT
130 FORK=1TO4:FORK1=1TO8:D(X1,X,1)=200:NEXTX1,X
140 FORK=1TO200:TL(X)=1800:NEXT
150 CLS
160 INPUT"WILL A PRINTER BE USED (Y/N)";A$:IF A$="N" THEN CLS:GOTO218
170 PRINT"MEMORY SIZE MUST HAVE BEEN SET AT 32677":PRINT"LOADING SCREEN PRN
NT ROUTINE..."
180 FORK=32678TO32767:READY:POKEK,Y:NEXT
190 POKE 16526,166:POKE16527,127:A=USR(0):PRINT"SCREEN PRINT DRIVER LOADED.
SCREEN CAN BE PRINTED AT ANY TIME
BY PRESSING SHIFT & SPACE SIMULTANEOUSLY"
200 INPUT"PRESS ENTER TO CONTINUE";Z:CLS
210 PRINT"THIS PROGRAM COMPUTES GOLF SCORES USING THE POPULAR CALLOWAY"
220 PRINT" HANDICAP SYSTEM. THIS SYSTEM BASES EACH PLAYER'S HANDICAP"
230 PRINT" ON THEIR GROSS SCORE. A CERTAIN NUMBER OF HOLES (AND HALF"
240 PRINT" HOLES) ARE DEDUCTED AND AN ADDITIONAL ADJUSTMENT RANGING FROM"
250 PRINT" -2 TO +2 IS COMPUTED FOR EACH PLAYER."
260 PRINT"PRINT THE FOLLOWING ASSUMPTIONS AND RULES APPLY (UNLESS MODIFIED)"
270
270 PRINT" 1. ONLY THE FIRST 16 PLAYED HOLES MAY BE CONSIDERED FOR"
280 PRINT" DEDUCTION. (ACTUAL HOLES DEPEND ON STARTING HOLE)"
290 PRINT" 2. MAXIMUM DEDUCTION FOR ANY HOLE IS LIMITED TO TWICE PAR"
300 PRINT" FOR THAT HOLE. (VARIES FOR MALE, FEMALE)"
310 PRINT" 3. HALF STROKES (ON HALF HOLES) ARE DEDUCTED AS FULL STROKES."
320 PRINT"PRINT"ENTER COURSE PAR SCORE FOR EACH HOLE. MEN'S FIRST."
330 FORK=1TO18:PRINT"HOLE # ";X;:INPUT(X,1):IF P(X,1)=0 PRINT"ERROR":INPUT(X,1)
340 NEXT
350 PRINT"NOW ENTER WOMEN'S PAR FOR EACH HOLE."
360 FORK=1TO18:PRINT"HOLE # ";X;:INPUT(X,2):IF P(X,2)=0 PRINT"ERROR":INPUT(X,2)
370 NEXT
380 CLS
390 PRINT
400 PRINT"PAR SCORES FOR THIS TOURNAMENT ARE NOW SET AS FOLLOWS:"
410 PRINT" FRONT 9 BACK 9"
420 PRINT" HOLE MEN WOMEN HOLE MEN WOMEN"
430 A$=" "
440 FORK=1TO9
450 PRINT USING A$:X,P(X,1),P(X,2),X+9,P(X+9,1),P(X+9,2)
460 NEXTX:PRINT
470 INPUT"BIT ENTER TO CONTINUE (BREAK & RESTART IF WRONG)";X
480 CLS
490 INPUT"DO YOU ALLOW GUESTS TO COMPETE (Y/N)";A$:IF A$="Y" THEN G=1:PRINT"
INCLUDE 'GUEST' AS A DEPARTMENT"
500 INPUT"NUMBER OF UNITS/DEPARTMENTS";ND
510 FORK=1TOND:PRINT"UNIT/DEPT # ";X;:INPUTDP(X):NEXT
520 DP(X)=0:"GUEST"
530 CLS:PRINT"SEVERAL SUMMARIES ARE AVAILABLE WHENEVER 'NAME' IS ON THE SCK
EEN"
540 PRINT" # SUMMARY";PRINT
550 PRINT" 1 LOW FOURSOME NETS"
560 PRINT" 2 LOW GROSS WINNERS (MAX=10)"
570 PRINT" 3 LOW NET WINNERS (MAX=10)"
580 PRINT" 4 UNIT STANDINGS"
590 PRINT" 5 HOLE AVERAGES"
600 PRINT" 6 TOTAL NET SCORE BY INDIVIDUAL";PRINT:IFND="S" RETURN
610 PRINT"TO PRODUCE A SUMMARY, TYPE 'S' AFTER 'NAME?'"
620 NF=0:INPUT"HOW MANY PLAYERS IN THIS GROUP?";NF:IFNF=0 THEN G=0
630 INPUT"GROUP ID NUMBER";FU
640 INPUT"STARTING HOLE (1 OR 18)";SH:IFSH=0 SH=1
650 NN=0:GF=0
660 NN=NN+1
670 N$="":INPUT"NAME";N$:IFN$="" N$="S"
680 IFN$="S" THEN 750
690 CLS:PRINT"UNIT #","DEPARTMENT"
700 FORK=GSTOND:PRINTX,DP(X):NEXT
710 PRINT:INPUT"UNIT #";U
720 IF U=0 THEN GF=1:"SETS GUEST FLAG"
730 IF LEN(N$)>10 THEN N$=LEFT$(N$,10)
740 GOTO 780
750 F=0:CLS:GOSUB 540:INPUT"SUMMARY #";F
760 ONFGOSUB 2030, 2090, 2130, 2170, 2280, 2340
770 GOTO670
780 SS="":INPUT"MALE OR FEMALE (M/F)";S$:IF S$="" S$="M"
790 T1=0:T2=0:G=0:H1=0
800 NP=NP+1
810 IF SS="F" S=2:GOTO 830
820 S=1
830 CLS:PRINT"INPUT HOLE SCORES FOR 1-9 (REGARDLESS OF STARTING HOLE)"
840 INPUT S(1),S(2),S(3),S(4),S(5),S(6),S(7),S(8),S(9)
850 T1=0
860 FORK=1TO9:T1=T1+S(X):NEXTX
870 PRINT"FIRST NINE HOLES--TOTAL=";T1
880 PRINT"INPUT HOLE SCORES FOR 10-18 NOW..."
890 INPUT S(10),S(11),S(12),S(13),S(14),S(15),S(16),S(17),S(18)
900 T2=0
910 FORK=10TO18:T2=T2+S(X):NEXTX
920 G=T1+T2
930 PRINT"BACK NINE TOTAL--";T2;" 18 HOLE GROSS--";G
940 X=1
950 PRINT"ENTER (1) TO GO ON"
960 PRINT" (2) TO RE-ENTER ALL SCORES"
970 PRINT" (3) TO RE-ENTER BACK NINE ONLY"
980 INPUTX:ONXGOTO 990, 830, 880
990 "COPY SCORES INTO TEST MATRIX
1000 G=T1+T2
1010 FORK=1TO18:T(X)=S(X):NEXT
1020 "FIGURE CALLOWAY ADJUSTMENT
1030 IFG>7 THEN 1060
1040 CLS:PRINTS;" GROSS=";G
1050 NE=G:PRINT"SCRATCH GOLFER--NO HANDICAP...":GOTO 1390
1060 IFG>7 THEN 1090
1070 N=1:IF1=1A=C-75
1080 GOTO 1150
1090 G1=(G-66)/10:N=INT(G1):IFG1-INT(G1)>.49 THEN 1110
1100 F1=0:GOTO 1120
1110 F1=1:N=N+1
1120 A=G-78
1130 IF A<2 THEN 1150
1140 A=A-5:GOTO 1130
1150 "START LOOKING FOR HIGH HOLES
1160 IF F1=1 THEN N=N-.5:GOTO 1180
1170 N=N
1180 CLS:PRINTS;" GOLFER # ";NF:PRINT"HOLES TO DEDUCT--";N9;" ADJUSTMEN
T=";A;" GROSS--";T1+T2
1190 PRINT" HOLE# DEDUCT"
```

```
1200 FORK=1TON "LOCATES 'N' HOLES
1210 T(L1)=0:FL=0
1220 L=L1+1:IFSH<1GOTO 1270
1230 FORK=1TO16:GOSUB 2420
1240 NEXTX
1250 GOSUB 1970
1260 GOTO 1320
1270 FORK=1TO18
1280 IFX=8ORX=9 THEN 1300 "BLOCKS HOLES 8&9 ON BACK NINE START
1290 GOSUB 2420
1300 NEXTX
1310 GOSUB 1970
1320 ON FL+1 GOTO 1330, 1340, 1350
1330 PRINTL1,G:GOTO 1360
1340 PRINTL1,L," SUBTRACT HALF HOLES":GOTO 1360
1350 PRINTL1,L," LIMITED TO 2 X PAR"
1360 NEXTX
1370 PRINT"TOTAL DEDUCT ";H1;" TOTAL HANDICAP ";H1+A
1380 NE=G-(H1+A)
1390 PRINT"SCORE #";NF;" ";NS;" * * * * NET SCORE * * * * ";NE:PRINT
1400 IF0=GGOTO 1830 "BLOCKS GUESTS FROM COMPETITION
1410 "LOW GROSS CALC
1420 FORK=1TO18
1430 IFG>M(X):GOTO 1480
1440 FORK1=10TOX STEP-1
1450 M(X1+1)=M(X1):MS(X1+1)=MS(X1):NEXT X1
1460 M(X)=G:MS(X)=NS
1470 PRINT"PRESENT MEDALIST CONTENDER.#";X:GOTO 1490
1480 NEXT X
1490 "UNIT WINNER CALC
1500 FORK=1TO4
1510 IFNE>D(U,X,1):GOTO 1590
1520 IFNE<D(U,X,1):GOTO 1540
1530 IFG>D(U,X,2):GOTO 1590
1540 FORK1=4TOX STEP-1
1550 FORI=1TO2
1560 D(U,X1+1,I)=D(U,X1,I):DS(U,X1+1)=DS(U,X1):NEXTI,X1
1570 D(U,X,1)=NE:D(U,X,2)=G:DS(U,X)=NS
1580 PRINT"PRESENT UNIT REPRESENTATIVE.#";X:GOTO 1600
1590 NEXTX
1600 "LOW NET CALC
1610 FORK=1TO18
1620 IFNE>LN(X,1):GOTO 1690
1630 IFNE<LN(X,1):GOTO 1650
1640 IFG>LN(X,2):GOTO 1690
1650 FORK1=10TOX STEP-1
1660 FORI=1TO2:LN(X1+1,I)=LN(X1,I):LNS(X1+1)=LNS(X1):NEXTI,X1
1670 LN(X,1)=NE:LN(X,2)=G:LNS(X)=NS
1680 PRINT"PRESENT LOW NET CONTENDER...";X:GOTO 1700
1690 NEXTX
1700 "TOTAL PLAYER COUNT, STORES ALL NET SCORES, SUMS HOLE TOTALS
1710 FORK=1TO NP
1720 IFNE>T1(X):GOTO 1790
1730 IFNE<T1(X):GOTO 1750
1740 IFG>G(X):GOTO 1790
1750 FORK1=NPTOXSTEP-1
1760 G(X1+1)=G(X1)
1770 T1(X1+1)=T1(X1):F(X1+1)=F(X1):TS(X1+1)=TS(X1):NEXTX1
1780 T1(X)=NE:F(X)=F:TS(X)=NS:G(X)=G:GOTO1800
1790 NEXTX
1800 FORK=1TO18
1810 HT(X)=HT(X)+S(X):NEXTX
1820 FT=FT+NE
1830 IF NN<NF THEN G=0
1840 NN=0
1850 IFNF<>4 THEN 1960
1860 IF GF=1 THEN 1960 "GUEST EXCLUSION FLAG
1870 INPUT"PRESS ENTER TO CONTINUE";Z:CLS
1880 FORK=1TO16
1890 IFPT=FF(X,2) THEN 1940
1900 FORK1=10TOXSTEP-1
1910 FF(X1+1,1)=FF(X1,1):FF(X1,2)=FF(X1,2):NEXTX1
1920 FF(X,1)=FU:FF(X,2)=FT
1930 PRINT"PRESENT FOURSOME CONTENDERS # ";X:GOTO1950
1940 NEXTX
1950 PRINT"FOURSOME NET TOTAL.";FT
1960 FT=0:INPUT"PRESS ENTER TO CONTINUE";Z:CLS:GOTO620
1970 T1(X1)=F(L1,S) THEN 1990
1980 L=L2+P(L1,S):FL=L2
1990 IFH<N THEN 2020
2000 IF FL<L THEN 2020
2010 L=INT(L/2+.9):FL=L
2020 H1=H1+L:RETURN
2030 CLS:PRINT"FOURSOME NET CONTENDERS"
2040 PRINT"RANK","FOURSOME","NET"
2050 FORK=1TO18
2060 PRINTX,FF(X,1),FF(X,2)
2070 NEXT
2080 RETURN
2090 "DISPLAY LOW GROSS
2100 CLS:PRINT"LOW GROSS (MEDALIST) CONTENDERS"
2110 FORK=1TO18:PRINT X,MS(X),M(X):NEXTX
2120 RETURN
2130 "DISPLAY LOW NET
2140 CLS:PRINT"LOW NET CONTENDERS"
2150 FORK=1TO18:PRINT X,LNS(X),LN(X):NEXTX
2160 RETURN
2170 "DISPLAY UNIT STANDINGS
2180 CLS
2190 INPUT"WHICH UNIT TO DISPLAY (1-8)";X
2200 DT=0
2210 PRINT"DEPARTMENT#--";X,DP(X)
2220 FORK1=1TO4
2230 PRINTDS(X,X1),D(X,X1,1):DT=DT+D(X,X1,1)
2240 NEXTX1
2250 PRINT"UNIT TOTAL--";DT:PRINT:PRINT
2260 INPUT"ANOTHER UNIT (Y/N)";A$:IF A$="Y" THEN CLS:GOTO2190
2270 RETURN
2280 "DISPLAY HOLE AVERAGES
2290 PRINT"CURRENT HOLE AVERAGES"
2300 CLS:PRINT" HOLE AVG HOLE AVG"
2310 FORK=1TO9:RA=HT(X)/NF:HB=HT(X+9)/NF:PRINTX,RA,X+9,HB:NEXTX
2320 PRINT:PRINT:PRINT
2330 RETURN
2340 "DISPLAYS ALL NET SCORES
2350 CLS:PRINT"NET SCORES";PRINT"RANK NAME NET"
2360 FORK=1TO9P
2370 FORV=1TO10
2380 PRINTX,TS(X),T1(X)
2390 NEXTX:PRINT:INPUT"PRESS ENTER TO CONTINUE";Z:CLS:PRINT"RANK","NAME","
ET"
2400 NEXTX
2410 RETURN
2420 IF T(X)>L THEN 2470
2430 IF T(X)<L THEN 2450
2440 IF T(X,S)<=L THEN 2470
2450 IF 2=2(X,S):L:GOTO 2470
2460 L=T(X):L1=X:P1=P(X,S)
2470 RETURN
```

MEMOREX FLEXIBLE DISCS

WE WILL NOT BE UNDER-SOLD! Call Free (800)235-4137 for prices and information. Dealer inquiries invited and COD's accepted.

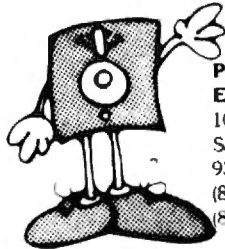

PACIFIC EXCHANGES
100 Foothill Blvd
San Luis Obispo, CA
93401 In Cal. call
(800)592-5935 or
(805)543-1037

✓207



TOTAL DISKETTE BACKUP
INCLUDING UNLIMITED BACKUP OF MOST PROTECTED DISKS

If your diskette software library is not completely backed up, or, if you are wasting diskettes by making backup copies of all your diskettes, your problem is solved! Using DUMPLoad, the total contents of your diskettes can be safely dumped to tape. The hi-speed tape option allows six 35 or 40 track diskettes to fit on one C60 cassette.

- TRS-80 Model 1 16K - 48K
- TRSDOS or NEWDOS80 Compatible
- May be used to back-up TRSDOS, VTOS 4.0, NEWDOS, MICRODOS, or data disks. (Single Density)

— \$16.95 on Cassette — \$19.95 on Diskette
Plus \$1.00 handling (Indiana Res. add 4% tax)
TOLL FREE 24 HR. ORDERING SERVICE
1-800-525-9391 (Ext. 509) (Except Colo.)
1-800-332-9259 (Ext. 509) (Colo. Residents)
or Mail Check or Money Order To:
COMPLETE COMPUTER SERVICES ✓210
8188 HEATHER DRIVE
NEUBURGH, INDIANA 47630



GET YOUR TRS-80 DIRECT FROM

AUTHORIZED SALES CENTER
FORT WORTH COMPUTERS AND VIDEO
377 PLAZA, HWY 377 GRANBURY
FORT WORTH, TX 76048 ✓214

AND SAVE \$

FREE! Zenith Color TV, NEW 1982 Model, with every MOD II or equivalent.

Get our quote "before" you buy.
Full manufacturers' warranties.
Texas residents add 4% sales tax.

817-573-4111

COST OF CALL REFUNDED FOR ORDERS BY TELEPHONE

TRS-80™ BUSINESS SOLUTION

Tired of switching printer cables between printer #1 and printer #2? Here is the solution. The Model SW17-A Printer Switcher is your answer. The SW17-A Switcher is a solid-state (no relays) printer switcher designed with your office efficiency in mind—simple to operate, with the single remote switch, yet positive in operation. Absolutely no data dropout. Available for TRS-80™ Model I, II, III, cables, remote switch, and power supply are included. 1 year limited warranty.

\$249.95

Please specify computer and printer models, sorry, no C.O.D.

Wizard Electronics, Inc.
P.O.B. 47842 • Doraville, GA 30362
404-261-2653

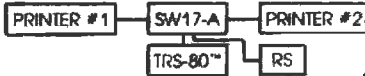

✓381

TRS-80™ is a registered trademark of Tandy Corporation

EDUCATIONAL SOFTWARE

For TRS-80* Color Computer, PET, Apple II.

- | | |
|-----------------------------------|-------------------------------|
| ELEMENTARY MATH | SCIENCE HISTORY |
| GEOGRAPHY ACCOUNTING | ECONOMICS BUSINESS ED. |
| FOREIGN LANG. FARM RECORDS | GRAMMAR COIN INVENTORY |

Write for FREE Catalogue:
MICRO LEARNINGWARE ✓209

BOX 2134, N. MANKATO MN 56001
507-625-2205

VISA & MASTER CHARGE ACCEPTED

We pay 15% royalty for Educational Programs listed with us.
Apple is a trademark of Apple Computer Co.
TRS-80 is a registered trademark of TANDY CORP.
Pet is a trademark of Commodore Bus. Machines.

— Professional —

REAL ESTATE SOFTWARE

for APPLE, TRS-80 & CPM SYSTEMS

- **PROPERTY MANAGEMENT SYSTEM: \$375**
 - Tenant History
 - Late Rent Report
 - Vacancy Report
 - Income Report
 - Auto Late Charge
 - Returned Checks
 - Operating Stmt
 - Building Reports
 - Utilities Report
 - Tax Expense Report
 - Prints Checks
 - Prints Receipts
- **PROPERTY LISTINGS/COMPARABLES: \$325**
 - SCREEN BY —
 - 22 Items/Listing
 - 1000 Listing/Disk
 - Listing Memo Field
 - Max/Min Price
 - Units/Zones/City
 - Max Price/Income
 - Max Price/Sq Foot
 - Min Cashflow
- **REAL ESTATE ANALYSIS MODULES: \$50/Module**
 - Home Purchase
 - Income Prop Analysis
 - Property Sales
 - Construction Cost/Profit
 - Tax Deferred Exchange
 - APR Loan Analysis
 - Loan Amortization
 - Depreciation/ACRS Analysis
- **WORD PROCESSOR — MAGIC WAND: \$285**



All Computer Stores Everywhere
or Order C.O.D. Direct
Cal Residents add 6% Sales Tax
(213) 372-9418

Suite E, 1116-8th Street, Manhattan Beach, CA 90266

PORTFOLIO ANALYSIS

Track and Analyze your stock portfolio with these programs for the TRS-80™ Mod I & 3.

The Stock Analysis Package consists of four programs which allow Database creation & maintenance, Graphing of prices, moving avg. & volume, and Generation of a Portfolio Analysis Report to evaluate your market position.

Programs are written in BASIC and are MENU driven with Error Trapping for ease of use.

TRS-80™ Mod I or 3, 48K & one disk drive required. Printer required for Portfolio Analysis report. Price for the entire package is \$74.95. To order or to receive more information, fill out coupon below or call (214) 867-5656. VISA & MC are accepted.

P.Tree Enterprises Suite 269
2701-C West 15th Street Plano, Texas 75075

Payment enclosed or charge my VISA MC
 Please send more information

Name _____

Address _____

City _____ State _____ Zip _____

Account # _____ Exp Date _____

*TRS-80 is a trademark of the Tandy Corp. ✓383

LYNX TRS-80 MODEM

\$229⁹⁸
DELIVERED

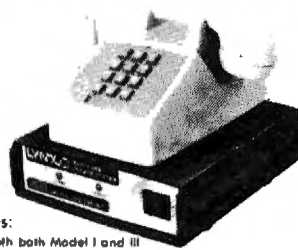

LYNX Features:

- Compatibility with both Model I and III
- No separate purchases required
- One-year warranty
- Auto dial Auto answer
- Works with any modems, including ST 80 by MCKELV
- Active CLEAR BREAK, and CONTROL keys
- Half or full duplex, variable word length, parity, and stop bits
- Dial from phone keyboard or memory
- Works with or without Model III RS 232 card
- Can be placed on either side of Model III
- No tools needed for install!

HIGH TECHNOLOGY AT AFFORDABLE PRICES

THE BOTTOM LINE ✓306

Orders & Information
(603) 673-8857

Orders Only
(800) 343-0726

12 Johnson Street, Milford NH 03055-0423

TRS-80 MODEL I T.M.* GOLDPLUG - 80

Eliminate disk re-boots and data loss due to poor contact problems at card edge connectors. The GOLD PLUG - 80 solders to the board card edge. Use your existing cables.

CPU/keyboard to expansion interface. . . . \$18.95
Expansion interface to disk, printer, RS232, screen printer (specify) \$9.95 ea
Full set, six connectors. . . \$54.95



EAP COMPANY
P.O. Box 14, Keller, TX 76248
(817) 498-4242

*TRS-80 is a trademark of Tandy Corp.

✓216

Using the Indexed Sequential Addressing Mode.

I Program Therefore ISAM

Richard S. Adcock
141 NW Lorna
Burleson, TX 76028

You have just purchased a book on exotic programming techniques. You open it to the table of contents. There you find one entry, "Exotic Programming Techniques," which begins on page one. You proceed to the back of the book; as you feared, there is no index. What do you do?

You have two choices. You can start at the beginning of the book and read from front to back, or you can haphazardly open the book to a page and see what's there. In computer jargon, you will either read the text sequentially or randomly. Either way, you will probably be able to get from cover to cover.

The catch comes sometime later when you have a problem and want to check your new book for a solution. Without an index you either have to start at the beginning of the book turning a page at a time or randomly access each page, hoping to find your answer. You would find either approach frustrating and time-consuming.

Now, consider this situation. You are writing a mail list program. Are you going to set up sequential or random data files? How are you going to recover records from your data files? Are you going to start at the beginning and thumb through until you find the end or will you just randomly sample the data files until you find the one you are looking for? Maybe you should index those files.

This is what happens in an Indexed Sequential Access Method File, ISAM for short. You create a data file, as well as an

index for it. If you need Jane Doe's address, you ask the computer to check the index for Jane Doe, get the associated record number and then the record. This is similar to the technique used to access a random file. Rather than use a hit and miss search, you give the computer a number which is either the record number for Jane Doe's file or a number somehow related to the record number. But people use computers so they will not have to keep track of numbers. It is easy to remember someone's name, but difficult to recall a number associated with it. You can look up the number on a printout, but if you do that, you might as well check a complete printout.

Commercial ISAM's

You can add ISAM to your programs in several ways. You can utilize someone else's ISAM routines. Johnson Associates and Racet Computes, for instance, offer a complete set of routines which you call up when you want to perform any file manipulation such as add records, delete records or search the file. Also, ISAM routines are built into Radio Shack's Compiler Basic and Cobol. These approaches have their advantages, but they have their disadvantages as well. You have to pay for them. Then, if you sell a program which uses these routines, you must pay a user's fee.

The second problem, which is more severe for Compiler Basic

```

1 'ADD ISAM RECORDS
10 CLEAR 1000: I=0
20 DIM N2$(50),N2(50)
30 OPEN "I",1,"INDEX"
40 I=I+1
60 INPUT#1, N2$(I), N2(I)
70 PRINT N2(I), N2$(I)
75 IF N2$(I)="EOF" THEN 90
80 GOTO 40
90 CLOSE
100 OPEN "R",1,"TEST"
110 FIELD 1, 10 AS N$, 245 AS D$
120 K=I-2
130 K= K+1
140 INPUT "WORD (UP TO 10 LETTERS)": N1$
150 IF N1$="" THEN 220
160 INPUT "DEFINITION (UP TO 245 CHARECTERS)":D1$
170 LSET D$=D1$
180 LSET N$=N1$
190 PUT 1,K
200 N2$(K)=N1$: N2(K)=K
210 GOTO 130
220 CLOSE
230 OPEN "O",1,"INDEX"
240 FOR I= 1 TO K
250 PRINT#1, N2$(I),",",N2(I)
260 NEXT I
265 PRINT#1,"EOF";",",999
270 CLOSE
280 RUN "ISAM"

```

Program Listing 2

```

1 'ISAM MENU
10 CLS
20 PRINT:PRINT "
                <1> ADD RECORDS
                <2> GET A RECORD
                <3> DELETE A RECORD
                <4> CREATE A FILE"
30 PRINT: INPUT "WHAT'S YOUR PLEASURE";M1: IF M1<1 OR M1>4 THEN
PRINT "NOT A GOOD CHOICE.":GOTO 30
40 ON M1 GOTO 60,70,80,90
60 RUN "ISAMADD"
70 RUN "ISAMRD"
80 RUN "ISAMDLT"
90 RUN "ISAMCPS"

```

Program Listing 1. ISAM menu

```

1 'RECOVER ISAM RECORD
10 CLEAR 1000: I=0
20 DIM N2$(50),N2(50)
30 OPEN "I",1,"INDEX"
40 I=I+1
60 INPUT#1, N2$(I), N2(I)
70 PRINT N2(I), N2$(I)
75 IF N2$(I)="EOF" THEN 90
80 GOTO 40
90 CLOSE
100 OPEN "R",1,"TEST"
110 FIELD 1, 10 AS N$, 245 AS D$
120 INPUT "WHAT'S YOUR WORD (UP TO 10 CHARACTERS)":N1$
130 IF N1$="" THEN CLOSE: RUN "ISAM"
140 FOR J=1 TO I
150 IF N2$(J)=N1$ THEN K=N2(J): GET 1,K: PRINT D$: GOTO 120
160 NEXT J
170 PRINT "SORRY, THAT WORD'S NOT ON FILE": GOTO 120

```

Program Listing 3

and Cobol than with the Johnson or Racet routines, is that you have to learn how to use them. If you use a set of routines you do not understand, then you increase your chances of getting into a you-can't-get-there-from-here situation. This is especially true if you use a DOS other than the one Tandy supplies. For instance, try running Radio Shack Cobol under DOS 3.3 from MSS. It hasn't worked for me, which is frustrating because I would like to run 80-track double-sided disks with Cobol.

Build Your Own

The following programs will give you a foundation upon which to build your own ISAM routines. In my example, I use the routines to set up a dictionary. You can easily modify them to function as a mailing list program or as a simple inventory, and with some thought they will work for more complex, multi-key applications.

The only time you need to handle an ISAM file differently from a random file is when you add records, call up individual records or delete records. Before you can do any of these things, you must have a data file and in our case, an index file. Since my routines use a sequential file for index, you must first set it up. The following routine does the job.

```
10 OPEN "O",1,"INDEX"
20 CLOSE
```

After you enter this and type Run an index with zero entries will be created on drive 0. This is

as it should be, since your data file is currently empty.

Once you have created the index file, you are ready for Program Listing 2, the Add Entries routine. Lines 30-90 read the index into the computer. When you run it the first time, nothing is in the computer. However, on any subsequent program runs, the index will contain data.

Lines 100-210 are the data entry and write data to disk routines. Line 200 updates the index array consisting of N2\$() as the name (the key) and N2() as the associated record number. Variable K is set to the value of the last record in the index plus one. This assures that you will not overwrite any existing records.

Lines 220-270 write the index to disk. By using a sequential file for storage, you can store the index in a minimum of disk space. Since, in this application, we must read the entire index sequentially, there is no advantage to using a random access file.

When you run this program, you will be prompted to enter a word and a definition. To exit the routine, type an @.

Program Listing 3, which is even shorter than Listing 2, accesses the ISAM file. Lines 10-110 are identical in form and function to lines 10-110 in Listing 1. At line 120, the computer prompts you to enter the word in question. It then compares your word against the index. When the computer finds your word (line 150), it uses the associated record number stored at N2(J) to call up the word's definition. If

```
1 'DELETE ISAM RECORD
10 CLEAR 1000: I=0
20 DIM N2$(50),N2(50)
30 OPEN "Y",1,"INDEX"
40 I=I+1
50 INPUT#1, N2$(I), N2(I)
70 PRINT N2(I), N2$(I)
75 N2$(I)="EOF" THEN 90
80 GOTO 40
90 CLOSE
100 OPEN "R",1,"TEST"
110 FIELD 1, 10 AS N$, 245 AS DS
120 INPUT "WHAT WORD DO YOU WANT TO DELETE";N1$
130 IF N1$="" THEN 180
140 FOR J=1 TO I
150 IF N2$(J)=N1$ THEN K=N2(J): N2$(J)="*":LSET N$="*****":
LSET DS="*":PUT 1,R: GOTO 120
160 NEXT J
170 PRINT "SORRY, THAT WORD'S NOT ON FILE": GOTO 120
180 CLOSE: OPEN "O",1,"INDEX"
190 FOR J= 1 TO I
200 PRINT#1, N2$(J);",",N2(J)
210 NEXT J
220 CLOSE: RUN "ISAMCPS"
```

Program Listing 4

CENTRONICS 779 / RS LINE PRINTER I

MAKE YOUR PRINTER A REAL WORKHORSE WITH OUR NEW PRINTER CONTROLLER BOARD

Remove the controller board in your printer and plug ours in to add the following capabilities:

- Bidirectional printing
- Full UPPER/lower case ASCII *plus* TRS-80 graphics or DSE scientifics character sets in 9 x 7 dot matrix format (9 x 9 available as option — requires print head change)
- Motor control — turns off the motor when the printer is not in use
- 2048 character buffer
- Software selectable features
 - transfer protocol (XON/XOFF or none)
 - character densities (10, 12, 15, 16.5 cpi *plus* double width in each size)
 - self-test
 - plus more!

**Introductory price
\$295 assembled and tested**

for orders placed before 6/30/82

DSE Digital
Systems
Engineering

Suite 400 Carolyn Building
10400 Eaton Place
Fairfax, VA 22030

(703) 385-0900

VISA, MasterCard, check, COD accepted

✓269

the word is not in the file, the computer tells you this (line 170), then returns to line 120 to let you input another word. To exit the program enter an @.

You can add a routine to print each file you look up. Since the file on the disk is random, printing the whole file is simply a matter of getting each record successively and printing it.

You could use a similar technique to delete records from an ISAM file as you would use with a random file. To fully use your disk space, you should remove the holes left by deleted records. The ability to do this is a major advantage of ISAM.

Consider this situation. In a random file, if the first of 10 records goes into record number 3000, the computer will respond with a disk full error. The computer thinks if you have a record number 3000, you must have 2999 other records it must store. If each record fills 255 bytes, the file would require roughly 765,000 bytes.

ISAM eliminates this problem by tacking new records onto the end of the existing file. This add-to-the-end feature also makes it difficult to find an empty slot. Rather than look for empty slots, run Program Listings 4 and 5. Listing 4 deletes a record by marking it. The program marks the record by replacing the word in the data file with asterisks and the word in the index

with a single asterisk (this saves space). Now if you delete the record, the slot will still be filled with asterisks. When you run Listing 5, you create a new index by reading the data file sequentially. In the process you also eliminate all the marked records or the records which contain only blanks.

Listing 5 first reads a record. If it is a good record (that is, it does not contain asterisks, spaces or zeros), the program takes the word (key) and the next available record number and puts this information into

the index array. Then, using this newly stored record number, it writes the record back to disk. If it finds an empty record, it does not increment the index counter; instead, it gets the next record. If the next record is good, the program writes it over the last empty record and transfers the word and its updated record number to the index. This procedure continues until the entire data file has been processed and removes all the holes in the ISAM file. This routine also lets you reconstruct a bad index if such an event occurs.

These programs are suitable for a file structure which uses only one key. You can improve the programs by adding more keys. Simply increase the number of columns in the index array.

You can also speed up the programs. For instance, even though this routine can find any one of 1000 entries in no more than seven seconds, you can increase its speed by sorting the data, and then using a bisection table lookup search technique. It is like using a phone book. You open the book to the middle. Is the name before or after? You throw the invalid half out, then split the remaining half in half. You repeat this until you find the name you are looking for. Using this split-in-the-middle technique you can sift through a 10,000 item list in only fourteen comparisons. You will hardly notice the delay.

You can also use a split index. This is useful if your index exceeds available RAM. In my dictionary routine I could put half my files on drive 1 and the other half on drive 2. When I want to look up a word, the computer can tell by the word's first letter if it needs to load the index for words before M or the one for after. This slows the search process, but it allows you to index a large amount of information. You can have as many indices as you have room for. ■

```

1 'INITIATE OR COMPRESS ISAM FILE
10 CLEAR 1000; I=0;R=1
20 DIM N2$(50),N2(50)
30 OPEN "R",1,"TEST"
40 FIELD 1, 10 AS N$, 245 AS D$
50 FOR I=1 TO LOF(1):PRINT I,
70 GET 1,I
80 PRINT N$,
90 IF N$="" THEN GOTO 280
100 IF N$="0" THEN 280
110 IF ASC(N$)=0 THEN 280
120 IF N$="" THEN 280
130 FOR V=1 TO LEN(N$)
140 IF MID$(N$,V,2)=" " THEN N2$(R)=LEFT$(N$,V-1):GOTO 160 ELSE IF V>9 THEN N2$(R)=N$:GOTO 160
150 NEXT V
160 N2(R)=R
170 LSET N$=N2$(R)
180 PRINT R
190 PUT 1,R
200 R=R+1
205 NEXT I:CLOSE
210 OPEN "O",1,"INDEX"
215 CLS
220 FOR I=1 TO R-1
230 PRINT N2$(I),N2(I)
240 PRINT#1, N2$(I);",",N2(I)
250 NEXT I
255 PRINT#1,"EOP";",",999
260 CLOSE
265 OPEN "R",1,"TEST":FIELD 1, 10 AS N$,245 AS D$
270 FOR I=R TO LOF(1):LSET N$="":LSET D$="":PUT 1,I:NEXT I
275 RUN "ISAM"
280 'ROUTINE TO BLANK A RECORD
290 LSET N$="":LSET D$="": PUT 1,I:GOTO 265

```

Program Listing 5

- TRS - 80⁽¹⁾ Model I or Model III
48K, 2 disks
TRSDOS⁽¹⁾ or LDOS⁽²⁾ formats available
PRICE \$149.50

- TRS - 80⁽¹⁾ Model II
64K, 2 disks
TRSDOS⁽¹⁾ format expanded version
PRICE \$224.50

GANTT-PACK: AUTOMATED PROJECT CHARTS

This powerful, flexible program will save you time in project planning, scheduling, tracking and reporting. You need no prior Gantt experience; screen prompts guide you all the way. Scratchpad entry lets you keep track of unassigned tasks while structuring your project. Automatic project organization. Fast edit lets you correct errors, modify schedules, explore alternatives. Saves alternative plans from original database. Helps you visualize the project at all stages.

Large capacity allows up to 100 tasks per phase and multiple phases per project, each phase with its own chart. Hard copy to parallel or serial printers. Scroll to any portion of any chart and print selected region. Charts show projected, elapsed and overrun times. Get professional results quickly and easily with Libra Lab's Gantt-Pack.



Libra Laboratories, Inc.
495 Main Street
Metuchen, N.J. 08840
(201) 494-2224

Gantt-Pack © Libra Laboratories, Inc. 1981
(1) TRS-80 and TRSDOS Trademarks of Tandy Corp.
(2) LDOS Trademark of Logical Systems, Inc.

Centronics 730

Same as Radio Shack
Line Printer II

Once \$995

Brand New

Now

\$399

While they last

Plus \$10 for shipping & insurance



Limited time only



5 1/4 Disc Drives

For TRS-80 Mod. 1 35 or 40 track capability

\$279

with power supply and cabinet

Single or double density (with proper interface)
Tandom drives

Add \$7.50 for shipping

5 1/4 Discs for TRS-80 and Apple

Prime First Quality

MEMOREX Discs as low as **\$1.89 per disc** In lots of 100

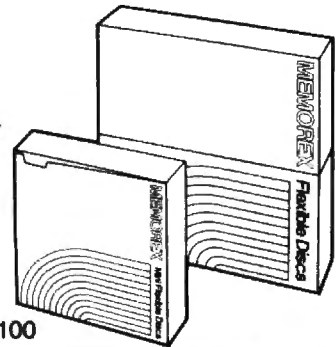

Part No.	10 or More	50 or More	100 or More
3401 SOLD OUT	\$2.09	\$1.99	\$1.89
3431 with Hubring	\$2.35	\$2.25	\$2.15

MiniMicroMart, Inc



943 W. Genesee St. Syracuse, N.Y. 13204 (315) 422-4467



A simple mod for the LNW interface.

Programmable Baud Rate

Hugh Cottle
P.O. Box 89
Concord, MA 01742

The LNW expansion interface is a good choice for many Model I owners who want to add memory and peripheral controllers at moderate cost. The printed circuit board is well made and the instructions are clear. The RS-232 interface works well but the UART parameters and the baud rate are selected by means of jumpers wired on the board. This is acceptable if you are going to dedicate the serial port to one device permanently, but unmanageable if you intend to use a variety of devices with different requirements.

You could use switches in place of the jumpers but your

control panels will have a home-made look that detracts from the appearance of your computer. Why add switch panels for a task the existing computer keyboard together with a little software can do just as well?

The jumpers that select the UART parameters do not directly control the UART; the program reads the parameters from the jumpers and then loads them to the UART. If software loads the parameters it need not read them from jumpers first; it can interrogate the user via the screen or load a set of preassigned values which you have stored in the program. With a small wiring change on the LNW board you can use the signals at socket U28 (normally used to read the jumpers) to drive a baud rate control circuit.

Making the Modification

The change deletes the signal IN E9H at socket U28 and replaces it with the signal OUT E9H, a spare output pulse available at IC U16. If you are making the change before you have wired the LNW board, remove pin 6 of the socket you install at location U16. Then add a short wire from pin 10 of U16 to the PC trace that would normally connect to

pin 6 of U16. That is all there is to this step. If you have already wired your LNW board, then either bend or cut off pin 6 of the

IC you put in location U16. In either case also add a jumper on the board between E5 and K to provide a logic high signal for the

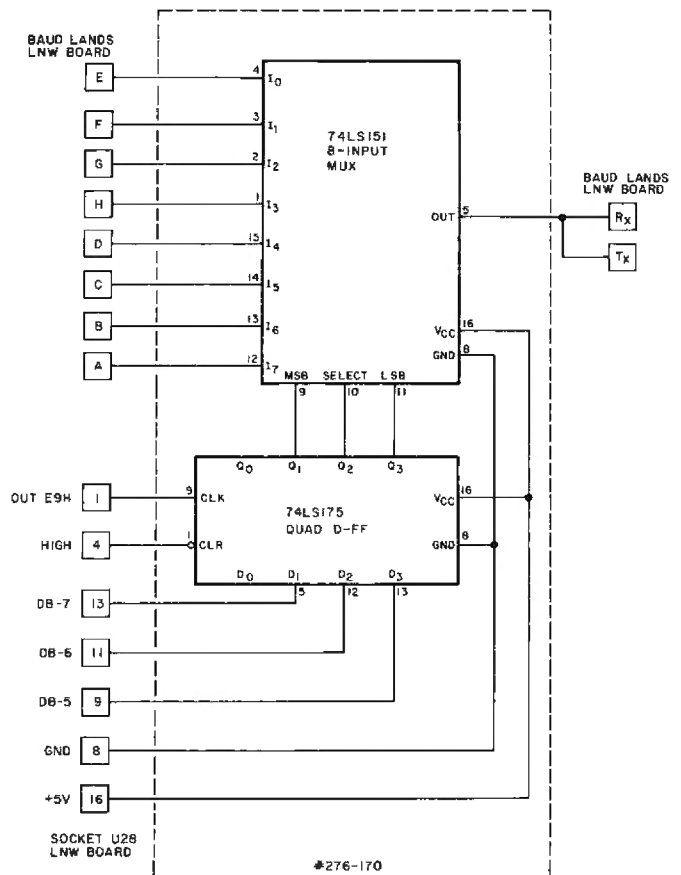

Fig. 1. Baud Rate Modification Logic Diagram

The Key Box

Basic Level II
Model I or III
16K RAM
LNW interface for Model I
RS-232 option for Model III

Baud Rate	X	Y
110	00H	00
150	20H	32
300	40H	64
600	80H	96
1200	80H	128
2400	0A0H	160
4800	0C0H	192
9600	0E0H	224

Table 1

necting to socket U28 on the LNW and for connecting to the baud rate locations on the LNW. Figure 1 shows the connections I made. Any other wiring scheme that connects the same points will do as well.

The 74LS151 IC is an eight-input multiplexer that passes one of the eight inputs through to the output. The signals applied to the selection inputs determine the input: when all three selection inputs are low (logic zero) input zero is passed through to the output; when all selection inputs are high (logic one) input seven is passed through to the output; and, for other values of selection inputs other inputs are passed through to the output.

The 74LS175 IC is a four-bit register that stores the value of data bits 5-7 whenever signal OUT E9H occurs. The stored values of these bits connect to the selection inputs of the multiplexer and thus the state of data bits 5-7 at the time of the OUT

E9H signal control which input of the multiplexer is passed through to the output. This selection remains in effect until the next occurrence of OUT E9H.

The Modification

With the circuit wired as shown in Fig. 1 and installed in the LNW you can select the baud rate by outputting a byte to I/O port E9H according to Table 1. In Z80 language use OUT (0E9H),X where X is the desired rate from the table. In Basic use OUT 233,Y where Y is the desired rate from the table.

You can select the UART parameters by outputting a byte to I/O port EAH according to Table 2. First reset the UART by outputting anything to I/O port 0E8H. Then output bit two plus the value from Table 2 to I/O port 0EAH. (Bit two enables output from the serial interface.) In Z80 language use OUT (0EAH),Z where Z is the desired value from the table. In Basic use OUT 234,W where W is the desired

Parameter	Choice	Z	W
Parity:	none	8H	8
	odd	0	0
	even	80H	128
# Bits:	5	0H	0
	6	40H	64
	7	20H	32
	8	80H	96
# Stop Bits:	1	0H	0
	2	10H	16

Table 2

control circuit. This change makes available at socket U28 data bits 3-7 and an output pulse you will use to strobe them to a baud rate control circuit. (You will also obtain +5 volts and ground from this socket to drive the control circuit.)

The remaining logic required for the baud rate selection consists of a flip-flop register to store the selection value and an eight-input multiplexer to steer the selected rate to the UART. I used an experimenter's PC board to hold the circuit. Four sockets soldered to the board provide for the two ICs needed and for con-

value from the table. Pick one of the three choices for parity, one of the four choices for number of bits, one of the two choices for number of stop bits and add the three Z or W values from the table to get the final value of Z or W for use in the output instruction. For example: even parity/8 bits/1 stop bit $Z = 80H + 60H + 0H + 4H = E4H$ ($W = 128 + 96 + 0 + 4 = 228$).

The above instructions are all you need to use the programmable baud rate modification. However, you can add a little class to your terminal program

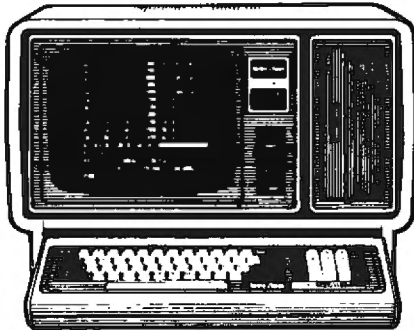

Model II
26-4002

\$3288⁰⁰

8 Megabyte

Hard Disk

(Primary)
26-4150.

\$3994⁰⁰

DISCOUNT TRS-80[®] Computers

We have the Largest Inventory in the Central United States. Discount prices on all software and accessories for your TRS-80 computer needs.

BUY

DIRECT

Toll Free Order:

1-800-835-9056

Kansas Residents:

1-800-362-9091

- ★ No out of state Taxes
- ★ Immediate Shipment
- ★ Several Payment Methods
- ★ Direct Buying

Jimscot, Inc. 254

P.O. Box 607 - 1023 N. Kansas

Liberal, Ks. 67901

**WRITE TODAY FOR YOUR
FREE CATALOG!**

* TRS-80 is a Registered Trademark of Tandy Corporation

!!NOW AVAILABLE!!



INDEX SEQUENTIAL ACCESS METHOD

- ★ Get and Put Records to Disk File by "KEY"
- ★ Read File in Key Sequence Without Sorting
- ★ Delete Records Without Recopying File
- ★ Add Records to Disk Files in Any Sequence
- ★ Variable Key Length From 1 to 50 Characters
- ★ Machine Language or Basic Subroutines.

BUSINESS APPLICATION ADVANTAGES

- Improved Disk Utilization
- Easier Program Development
- Improved Operating Characteristics
- Reduce or Eliminate Sorting
- Improved Performance

ISAM SUBROUTINES Documentation
ISAM UTILITIES On Diskette \$90.00

NEW! MACHINE LANGUAGE + BASIC SUBS — \$140

—PLUS—Free Mailing List Sample Application
Add 6% Sales Tax for California Orders

TRS-80[™] MODEL I, II, & III and CPM[®] SOFTWARE FROM:

Johnson Associates -or- Telephone Order Line
P.O. Box 3069 Redding, CA 96049 ✓150 For Bank Card Sales (916) 221-0740

WRITE FOR FREE CATALOG

COLOR COMPUTER SOFTWARE

EDITOR ASSEMBLER DEBUGGER \$6.95

CCEAD: This 8K Basic Program supports cassette files, has full cursor control, line insertion/deletion, and much more. Two pass assembler supports full 6809 instruction set & addressing modes, lists to screen or printer. Debugger allows memory examine/modify program execution. If not delighted return within 2 weeks for a full refund. You get fully commented Basic source & complete instructions. Requires Ext. Basic & 16K.... CASSETTE \$6.95

DELUXE TERMINAL PROGRAM

COLORCOM/E: This terminal program has everything! PLUS it's in a convenient plug-in cartridge. LOOK at these features:

- Complete upload & download support
- Automatic or manual capture
- Selectable baud rate & parity
- Selectable Capture characters
- Full or half duplex
- Exchange Basic programs
- Write to any printer or cassette
- Word mode means no split words
- Supports ANY serial printer
- And much, much more

Use with Compuserve, The Source, etc. Talk to other Color Computers. Works with any model Color Computer & full duplex RS232C modem. CARTRIDGE \$49.95

STRIPPER: The Stripper takes off all that excess fat in your Basic Programs. Three valuable commands: (1) Delete Remarks, (2) Pack Lines, (3) Delete Spaces. Fully automatic, is not fooled by GOTO's, GOSUB's, etc. Your programs will run faster and take up much less memory. CASSETTE \$7.95

BOOTSTRAP: This Cartridge automatically loads and executes Basic programs from cassette at power-up. Can't fail! Ignores data files, Machine Language files, or Basic files that have errors. For those programs that have to run! CARTRIDGE \$34.40

RS232C EXPANSION CABLE: With this cable you can connect 2 devices at the same time to the RS232C part of your Color Computer. Great for printer & modem. RS232C Cable \$20.00

CUSTOM CARTRIDGES: Put YOUR Basic program into a convenient ROM Cartridge. It's easy! Runs instantly at power-up, frees up memory. Use for Ad displays, schools, etc. Call or write for info. FROM \$41.65

Send check, money order or Visa/MC Number. Include \$1 for postage and handling; Visa/MC Phone for fast service.



P.O. Box 10234
Austin, Texas 78766
(512) 837-4565

✓154

BAUD = 300 # BITS = 8 #STOP = 1 PARITY = NONE

Figure 2

by using an RS-232C initialization program such as the one described below.

Program Listing 1 is written as a subroutine you can call from the beginning of your terminal program. When called it clears the screen and displays the information shown in Fig. 2.

Initialization Subroutine

The initialization program in

Program Listing 1

```

00100 *****
00110 ;
00120 ; SUBROUTINE TO SET RS232C PARAMETERS
00130 ; (LEVEL II, LNW, PROGRAMMABLE BAUD MODIFICATION)
00140 ; WRITTEN BY RUGH COTTLE OCTOBER 1981
00150 *****
00160 ; WHEN CALLED THE CURRENT VALUES OF THE PARAMETERS
00170 ; ARE DISPLAYED, USE RIGHT ARROW TO SELECT NEXT
00180 ; PARAMETER, DOWN ARROW TO SELECT NEXT VALUE; PRESS
00190 ; ENTER AFTER ALL SELECTIONS MADE TO INITIALIZE THE
00200 ; RS232C CHANNEL AND EXIT THE SUBROUTINE.
00210 ;
00220 ORG 00000H ; NEAR TOP OF 32K SYS
00230 SETGER JF START
00240
00250 *****CONSTANTS*****
00260 ;
00270 ; ROM ENTRY POINTS
00280 ;
00290 DSP EQU 33H ; CHAR IN A TO SCREEN
00300 KBD EQU 49H ; CHAR IN KEYBD TO A
00310 CLRSKR EQU 81C9H ; CLEAR SCREEN
00320 ;
00330 ; OTHER CONSTANTS
00340 ;
00350 RARW EQU 09H ; RT ARROW CODE
00360 DARW EQU 0AH ; DN ARROW CODE
00370 ENTER EQU 0DH ; ENTER KEY CODE
00380 TAG EQU 83H ; GRAPHIC CHAR CODE
00390 SPACE EQU 20H ; SPACE CODE
00400 BOUT EQU 0E9H ; OUT PORT FOR BAUD RATE
00410 POUT EQU 0EAH ; OUT PORT FOR UART PARA
00420 MR EQU 0E8F ; OUT PORT TO RESET UART
00430 VIDED EQU 3C00H ; START ADDR OP SCR NEM
00440 ;
00450 *****VARIABLES*****
00460 ;
00470 PARPTR DEFB 0 ; LINK TO CURRENT PARAMETER
00480 PAR1PT DEFB 0PAR ;
00490 PAR2PT DEFB 0PAR ;
00500 PAR3PT DEFB 0PAR ;
00510 PAR4PT DEFB 0PAR ;
00520 PSTROR DEFB 0 ; TEMP PTR STORAGE
00530 BAUD DEFB ' BAUD='
00540 NBITS DEFB ' # BITS='
00550 SPBITS DEFB ' # STOP='
00560 PARITY DEFB ' PARITY='
00570 ;
00580 ; BAUD RATE TABLE
00590 ; FLAG=0 NOT SELECTED VALUE
00600 ; =1 SELECTED VALUE
00610 ; =BPTH END OF SELECTIONS
00620 BPAR DEFB 0 ; FLAG
00630 DEFB '110' ; NAME OF SELECTION
00640 DEFB 0 ; VALUE OF SELECTION
00650 DEFB 0 ;
00660 DEFB '150' ;
00670 DEFB 20H ;
00680 DEFB 1 ;
00690 DEFB '300' ; DEFAULT SELECTION
00700 DEFB 40H ;
00710 DEFB 0 ;
00720 DEFB '600' ;
00730 DEFB 60H ;
00740 DEFB 0 ;
00750 DEFB '1200' ;
00760 DEFB 90H ;
00770 DEFB 0 ;
00780 DEFB '2400' ;
00790 DEFB 800H ;
00800 DEFB 0 ;
00810 DEFB '4800' ;
00820 DEFB 0C00H ;
00830 DEFB 0 ;
00840 DEFB '9600' ;
00850 DEFB 0E00H ;
00860 DEFB 0FFH ; TABLE END MARKER
00870 ;
00880 ; TABLE OF # BITS PARAMETER
00890 ;
00900 NPAR DEFB 0
00910 DEFB '5' ;
00920 DEFB 0 ;
00930 DEFB 0 ;
00940 DEFB '6' ;
00950 DEFB 40H ;
00960 DEFB 0 ;
00970 DEFB '7' ;
00980 DEFB 20H ;
00990 DEFB 1 ;
01000 DEFB '8' ; DEFAULT SELECTION
01010 DEFB 60H ;
01020 DEFB 0FFH ;

```

Program continues

Program continued

```

01030 ;
01040 ; TABLE OF 8 STDP BITS PARAMETER
01050 ;
BB74 01 01060 SPAR DEFB 1 ;DEFAULT SELECTION
BB75 31 01070 DEFB '1 '
BB79 00 01080 DEFB 0
BB7A 00 01090 DEFB 0
BB7B 32 01100 DEFB '2 '
BB7F 10 01110 DEFB 10H
BB80 FF 01120 DEFB 0FFH
01130 ;
01140 ; TABLE OF PARITY PARAMETER
01150 ;
BB81 01 01160 SPAR DEFB 1 ;DEFAULT SELECTION
BB82 4E 01170 DEFB 'NONE'
BB86 00 01180 DEFB 0
BB87 00 01190 DEFB 0
BB88 4F 01200 DEFB 'ODD '
BB8C 00 01210 DEFB 0
BB8D 00 01220 DEFB 0
BB8E 45 01230 DEFB 'EVEN'
BB92 00 01240 DEFB 00H
BB93 FF 01250 DEFB 0FFH
01260 ;
01270 ; PROGRAM
01280 ;
BB94 CDC901 01290 START CALL CLRSCR
BB97 010700 01300 LD SC,7
BB9A 210E00 01310 LD HL,BAUD
BB9D 11003C 01320 LD DE,VIDEO
BBAA EDB0 01330 LDIR ;DISPLAY BAUD=
BBA2 010700 01340 LD SC,7
BBA5 211500 01350 LD HL,NBITS
BBA6 11103C 01360 LD DE,VIDEO+16
BBA8 EDB0 01370 LDIR
BBA9 010700 01380 LD SC,7
BBB0 211C00 01390 LD HL,SPBITS
BBB3 11203C 01400 LD DE,VIDEO+32
BBB6 EDB0 01410 LDIR
BBB8 010700 01420 LD SC,7
BBBB 212300 01430 LD HL,PARITY
BBBE 11303C 01440 LD DE,VIDEO+48
BBC1 EDB0 01450 LDIR
BBC3 CD86BC 01460 CALL DSPVAL
BBC6 3E83 01470 LD A,TAG
BBC8 CD83BC 01480 CALL DSPUNL
BBCB CD4900 01490 KYBINP CALL KBD
BBCE FE09 01500 CP RARW
BBD0 CADFB0 01510 JP Z,NVAL
BBD3 FE0A 01520 CP DARW
BBD5 CA2500 01530 JP Z,NVAL
BBD8 FE0D 01540 CP ENTER
BBDA CA2CBC 01550 JP Z,INITRS
BBDD 10E0 01560 JR KYBINP
BBDF 3E20 01570 NSEL LD A,SPACE
BBE1 CD83BC 01580 CALL DSPUNL ;NEXT PARAMETER
BBE4 3A0300 01590 LD A,(PARPTR)
BBE7 3C 01600 INC A
BBE8 E603 01610 AND 3
BBEA 320300 01620 LD (PARPTR),A
BBED 3E83 01630 LD A,TAG
BBEF CD83BC 01640 CALL DSPUNL
BBF2 C3CBB0 01650 JP KYBINP
BBF5 3A0300 01660 LD A,(PARPTR) ;NEXT VALUE
BBF8 E603 01670 AND 3
BBFA 07 01680 RLCA
BBFB 210400 01690 LD HL,PARPTR+1
BBFE 1600 01700 LD D,0
BC00 5F 01710 E,A
BC01 19 01720 AND HL,DE
BC02 5E 01730 LD E,(HL)
BC03 23 01740 INC HL
BC04 56 01750 LD D,(HL)
BC05 EB 01760 EX DE,HL
BC06 220C00 01770 LD (PTRSTOR),HL
BC09 7E 01780 NVLP A,(HL)
BC0A FE01 01790 CP 1
BC0C 2006 01800 JR Z,NVLP1
BC0E 110600 01810 DE,6
BC11 19 01820 AND HL,DE
BC12 10F5 01830 OR NVLP
BC14 AF 01840 XOR A
BC15 77 01850 LD (HL),A
BC16 1600 01860 LD D,0
BC18 1E06 01870 LD E,6
BC1A 19 01880 AND HL,DE
BC1B 7E 01890 LD A,(HL)
BC1C FEFF 01900 CP 0FFH
BC1E 2003 01910 JR NZ,NVLP2
BC20 2A0C00 01920 LD HL,(PTRSTOR)
BC23 3E01 01930 LD A,1
BC25 77 01940 LD (HL),A
BC26 CD86BC 01950 CALL DSPVAL
BC29 C3CBB0 01960 JP KYBINP
BC2C D3E0 01970 INITRS OUT (NR),A ;RESET UART
BC2E 212AB0 01980 LD HL,SPAR
BC31 7E 01990 IBRLP1 LD A,(HL)
BC32 FE00 02000 CP 0
BC34 2006 02010 JR NZ,IBRLP2
BC36 110600 02020 LD DE,6
BC39 19 02030 ADD HL,DE
BC3A 10F5 02040 JR IBRLP1
BC3C 110500 02050 IBRLP2 DE,5
BC3F 19 02060 ADD HL,DE
BC40 7E 02070 LD A,(HL)
BC41 D3E9 02080 OUT (ROUT),A ;SET BAUD RATE
BC43 0E05 02090 LD C,5 ;BIT 2-1 TO EN RS232 DU
T
BC45 215000 02100 LD HL,NPAR
BC48 7E 02110 IUPLP1 LD A,(HL)
BC49 FE00 02120 CP 0
BC4B 2006 02130 JR NZ,IUPLP2
BC4D 110600 02140 LD DE,6
BC50 19 02150 ADD HL,DE
BC51 10F5 02160 JR IUPLP1
BC53 110500 02170 IUPLP2 DE,5
BC56 19 02180 ADD HL,DE
BC57 7E 02190 JR IUPLP3
BC58 31 02200 OR C
BC59 4C 02210 LD C,A
BC5A 217400 02220 LD HL,SPAR
BC5D 7E 02230 IUPLP3 LD A,(HL)
BC5E FE00 02240 CP 0
BC60 2006 02250 JR NZ,IUPLP4
BC62 110600 02260 LD DE,6
BC65 19 02270 ADD HL,DE
BC66 10F5 02280 JR IUPLP3
BC68 110500 02290 IUPLP4 LD DE,5
BC69 19 02300 ADD HL,DE
BC6C 7E 02310 LD A,(HL)
BC6D B1 02320 OR C
BC6E 4F 02330 LD C,A

```

Program continues

PRO-DEBUG *****

For TRS-80 Model II & III

- SINGLE STEP** - Through any area of memory
- STOP** - At any location in memory (except ROM)
- LOOP** - Through subroutines (except ROM)
- CALL** - Subroutines & programs from keyboard
- VIEW** - Z-80 registers & memory pointed to
 - Stack pointer & stack contents
 - PC. with it's instructions
 - Instructions in both opcode & mnemonics
- HUNT** - Memory for 16 bit word
- MODIFY** - Z-80 registers & any area of memory
- DISASSEMBLE** - Any area of memory into opcode, mnemonics & ascii

**THIS PLUS 23 ADDITIONAL
COMMANDS FOR \$45.00**

PRO-BASIC *****

Basic Enhancements For Model II & III

FEATURES INCLUDE

- * PRO-ANGLES
- * PRO-LABELS
- * PRO-EXTENSIONS
- * PRO-WORDS
- * PRO-EDIT
- * PRO-SORT
- * PRO-FUNCTIONS
- * PRO-DEBUG
- * PRO-KEYS
- * PRO-MACH
- * PRO-CRT
- * PRO-FILES
- * PRO-VRS
- * PRO-GRAPH

\$195.00 This includes the right to use the compiled Pro-Basic in programs you write for resale.

PRO-COPY *****

Disk Copy Utility For Model II

- * 30 sec. mirror image copy of 8 floppy disk
- * works on single or multiple drives
- * format option available
- * verify option available
- * format, verify & copy to a blank disk in 1 min.

PRICE \$50.00

TRS-80 is a registered trademark of Tandy Corp.

PRO-80-SYSTEMS

3206 Center Street
Cedar Falls, IA 50613
319-266-4262 or 319-233-6111

253

PLUG INTO...

ACCESS

The Journal of Microcomputer Applications

Numerical analysis, statistics, simulation, information retrieval, engineering design, engineering economics, project planning & management, personal finance, scientific & engineering applications. Subscribe now \$16 for 6 issues. Send check, money order or company purchase order to: ACCESS, P.O. Box 12847, Research Triangle Park, NC 27709

To: ACCESS, P.O. Box 12847
Research Triangle Park, NC 27709
Here's my \$16. Sign me up for 6 issues.

Name _____
Address _____
City _____
State _____ Zip _____

Published by LEDS Publishing Inc.

155

MICRO IMAGES

FREE SHIPPING WITHIN CONT. U.S.A.

EPSON CALL **OKIDATA**
FOR OUR LOW PRICES

RS232 Not. Req. **LYNX** Mod I/III \$259.95
includes auto dial/answer, cables and terminal software

VERBATIM Datalife 5 1/4 Box DD/ \$30.00
MD525-01 of 10 Add \$2.50 Plast. LIB case

SUPER UTILITY PLUS by Kim Watt Specify 40 or 80 Track \$69.95

SUPERSCRIPIT BY Acorn - Req. 32K, Scripsit & L/C - Disk \$44.95

EDITOR ASSEMBLER PLUS BY Microsoft - 16K Tape \$27.95

DOSPLUS Newest Version
- 3.4S/3.4D/3.4 III ea \$134.95

MAXI MANAGER by Adventure Int'l Latest Version 48K Disk \$84.95

UNITERM by Pete Roberts - Mod III Works with most modems \$74.95

MICROSOFT - FORTRAN 80-\$89.95 - A.L.D.S-\$89.95 - BASIC COMPILER-\$179.95

EDAS by Micosys Sophisticated Editor & Assembler \$75.95

LDOS Version 5.1 - Mod I or III \$118.95

LAZYWRITER LATEST VERSION - A Best Buy in Word Processors
- Mod I or III \$164.95

Proofreader by Aspen Software Mod I - 49.95 Mod III - 49.95

Proofedit by Aspen Software Mod I 28.50 Mod III - 28.50

Grammatik by Aspen Software Mod I - 55.95 Mod III - 55.95

MX 80 Ribbon Reloads - \$3.50 ea/\$38.00dz. Min. 5 ribbons

We also carry the full line of ADVENTURE INT'L, ACORN, BIG FIVE, BRODERBUND, AVALON HILL, MICROSOFT, DATASOFT, MISOSYS, AUTOMATED SIMULATIONS and most other line software at discount prices.

SEND FOR YOUR FREE CATALOG

No credit cards at these low prices. Add \$2.00 on all COD orders. Certified Check/MO/COD shipped immediately. Please allow 2 weeks for personal checks. For extra fast service phone in your COD order. Prices subject to change without notice. New York State residents please add appropriate sales tax.

We Offer Great Values & Prompt Delivery - Why Not Try Us?

146-03 25th Road, Flushing, New York 11354

Mon-Fri 10 AM-9 PM (212) 445-7124 Sat 10 AM-5 PM

Program continued

```

BC6F 2181BB 02340 LD HL,PPAR
BC72 7E 02358 IUPLP5 LD A,(HL)
BC73 F800 02360 CP 0
BC75 2806 02370 JR NE,IUPLP6
BC77 110660 02380 LD DE,6
BC7A 19 02390 ADD HL,DE
BC7B 10P5 02400 JR IUPLP5
BC7D 110500 02410 IUPLP6 LD DE,5
BC80 19 02420 ADD HL,DE
BC81 7E 02430 LD A,(HL)
BC82 B1 02440 OR C
BC83 D3BA 02450 OUT (FOUR),A
BC85 C9 02460 RET

;SET UART PARAMETERS
;EXIT PROGRAM

02470 ;
02480 ; SUBROUTINES
02490 ;

BC86 110600 02500 DSPVAL LD DE,6
BC89 212ABB 02510 LD HL,BPAR
BC8C 7E 02520 BLP1 LD A,(HL)
BC8D F801 02530 CP 1
BC8F 2083 02540 JR Z,SLP2
BC91 19 02550 ADD HL,DE
BC92 18P8 02560 JR BL1
BC94 23 02570 BLP2 INC HL
BC95 018400 02580 LD BC,4
BC98 11073C 02590 LD DE,VIDEO+7
BC9B EDB0 02600 LDIR ;DISPLAY BAUD
BC9D 110600 02610 LD DE,6
BCA0 215B00 02620 LD HL,WPAR
BCA1 7E 02630 NLP1 LD A,(HL)
BCA4 F801 02640 CP 1
BCA6 2083 02650 JR Z,NLP2
BCA8 19 02660 ADD HL,DE
BCA9 18P8 02670 JR NL1
BCAB 23 02680 NLP2 INC HL
BCAC 010400 02690 LD BC,4
BCAF 11173C 02700 LD DE,VIDEO+23
BCB2 EDB0 02710 LDIR ;DISPLAY #BITS
BCB4 110600 02720 LD DE,6
BCB7 2174BB 02730 LD HL,SPAR
BCBA 7E 02740 SLP1 LD A,(HL)
BCBB F801 02750 CP 1
BCBD 2083 02760 JR Z,SLP2
BCBF 19 02770 ADD HL,DE
BCD0 18P8 02780 JR BL1
BCD2 23 02790 SLP2 INC HL
BCD3 010400 02800 LD BC,4
BCD6 11273C 02810 LD DE,VIDEO+39
BCD9 EDB0 02820 LDIR ;DISPLAY #STOP BITS
BCDB 110600 02830 LD DE,6
BCDE 2101BB 02840 LD HL,PPAR
BCD1 7E 02850 PLP1 LD A,(HL)
BCD2 F801 02860 CP 1
BCD4 2083 02870 JR Z,PLP2
BCD6 19 02880 ADD HL,DE
BCD7 18P8 02890 JR PL1
BCD9 23 02900 PLP2 INC HL
BCDA 010400 02910 LD BC,4
BCDD 11373C 02920 LD DE,VIDEO+55
BCDE EDB0 02930 LDIR ;DISPLAY PARITY
BCDF C9 02940 RET
02950 ;
02960 ;

BCB3 4F 02970 DSPVAL LD C,A
BCB4 3A03BB 02980 LD A,(PARPTR)
BCB7 E603 02990 AND 3
BCB9 07 03000 RLCA
BCBA 07 03010 RLCA
BCBB 07 03020 RLCA
BCBC 07 03030 RLCA
BCBD 21403C 03040 LD HL,VIDEO+64
BCBF 1600 03050 LD D,0
BCF2 5F 03060 LD E,A
BCF3 19 03070 ADD HL,DE
BCF4 0606 03080 LD B,6
BCF6 79 03090 LD A,C
BCF7 77 03100 UNLPL1 LD (HL),A
BCF8 23 03110 INC HL
BCF9 18PC 03120 DJNZ UNLPL1
BCFB C9 03130 RET
BB00 03140 END SETSER
00000 TOTAL ERRORS

```

Pressing the right-arrow key deletes the bar under baud and displays a similar bar under # bits. Pressing the key again shifts the bar to the right again and after four presses the bar will be back to baud. Thus the right-arrow key selects one of the four parameters you can set for the RS-232 channel. Similarly, pressing the down-arrow key displays successive values of the selected parameter. With the bar at Baud, one press of the down-arrow key replaces the 300 by the next consecutive value, 600. Continued presses of the key will cycle through all of the allowed values for baud and begin over again. If you move the bar to one of the other parameters by pressing the right-arrow key, then the

down-arrow key will cycle through the allowed values of this parameter. When you have selected all of the desired values using the right and down-arrow keys press Enter to initialize the RS-232 channel to these values and exit the subroutine. If you want to use the initial values displayed simply press Enter to initialize and exit the subroutine.

The default values of the parameters in the subroutine are 300 baud, eight bits, one stop bit, and no parity. To change these values to the values you normally use, change the tables in the program. Each entry in the parameter tables consists of six bytes: the first byte is a flag indicating if this value has been

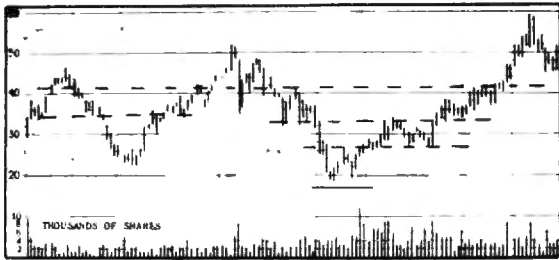

THE COMPUTER STOCK MARKET BOOK

THE PROFESSIONALS BUY

Purchased by over 160 Financial Institutions, 75 Market Advisory Services, 50 Colleges and Universities, and 150 Computer and Software Firms.

Has been sold in every state and over 30 other nations. It is a study of market timing based on cycles and seasonal factors, as they affect stock and commodity prices. It gives solid tools for measuring and profiting from them. Author has more than 20 years experience as a stock broker, and conducted 8 years of computer research developing the 34 programs in the book which contains ideas and programs never before published. Programs are written in TRS-80 BASIC.

Do you have the great stock and commodity trading advantages given by the home computer to the few who properly use it?

To order "New Uses For The Home Computer In The Stock Market" send your name and address with your check for \$19.95 (overseas, U.S.A. Dollar International Money Order or a Draft payable on a U.S.A. Bank) to:

Thomas V. Lenz, Dept. M
596 W. Karval Ct. - Spring Creek
Elko, Nevada 89801

✓ 144

MONEY BACK GUARANTEE



YORK 10 BASF-DPS

WORLD STANDARD TAPE

- PROFESSIONAL 5-SCREW SHELL
- UNIVERSAL INDUSTRY ACCEPTANCE

DATA TRAC — C-10, C-20
MUSI TRAC — C-45, C-90 ✓ 156

HERE'S WHAT USERS SAY ABOUT YORK 10 CASSETTES:

"Excellent tape — I haven't had a bad 'CLOAD' and volume level for all cassettes. Your tape is good enough for me to order more: enclosed is a money order for two dozen more cassettes."
Robert W. Bruggemeyer
Long Beach, CA

"The quality to price ratio is very high on these cassettes — had very good luck loading programs back to the computer."
Douglas Elkins
Millinocket, ME

"High quality tape in the proper lengths and at the right price. Keep it up..."
William E. Brown, Jr.
Reisterstown, MO

"YOU'VE TRIED THE REST, NOW BUY THE BEST"

Call: 213/710-1430 for IMMEDIATE SHIPMENT on Credit Card Orders.

ORDER NOW... Mail to: YORK 10 Computerware

Please send cassette checked below:

LENGTH	1 DOZEN	2 DOZEN	TOTAL
C-10	<input type="checkbox"/> 8.00	<input type="checkbox"/> 14.40	
C-20	<input type="checkbox"/> 10.00	<input type="checkbox"/> 18.00	
C-45	<input type="checkbox"/> 13.00	<input type="checkbox"/> 23.00	
C-90	<input type="checkbox"/> 21.75	<input type="checkbox"/> 39.00	
SUB TOTAL			
Call residents add 6% sales tax			
Shipping 1 doz \$2.2 doz \$3.50 add 1 doz \$1			
TOTAL			

24573 Kittridge St., #60H, Canoga Park, CA 91307

- Check or M.O. enclosed Charge to my Credit Card
 VISA MASTER CARD Expires date _____

account no. _____

name _____

address _____

city _____

state/zip _____

WRITE FOR QUANTITY DISCOUNTS

Shipped bulk pack by UPS to street address in Cont. U.S.A. only. We cannot ship to P.O. Boxes.



Creative Computer

1236 E. Colonial Drive
Orlando, Florida 32803 USA
Voice (305) 894-4744
BBS 24 Hour Electronic Mail
Order (305) 277-0473
Micronet 71555,520

Write For Free Catalog

Over 400 items in Diskettes, Paper, Labels, Ribbons, Checks, Storage Boxes, Furniture, Binders and Hardware. ® - Mfg. Trademark

FREE SHIPPING except hardware

CP/M

DISK WITH / MANUAL
MANUAL / ONLY

MICROPRO®

Super Sort I . . . \$192/\$36
Calc Star . . . \$250/\$36
Spell Star . . . \$175/NA
Word Star . . . \$315/\$54
Mail Merge . . . \$105/NA
Word Star/
Mail Merge . . . \$410/NA
Word Master . . . \$115/\$36
Data Star . . . \$244/\$54

MICROSOFT®

Basic-80 . . . \$285
Basic Compiler . . . \$325
Cobol-80 . . . \$570
Edit-80 . . . \$ 82
Fortran . . . \$345
Macro-80 . . . \$140
X macro-86 . . . \$255
M-Sort . . . \$120
Mu Math/
Mu Simp . . . \$220
Mu Lisp/
Mu Star . . . \$170
Typing Tutor . . . \$ 27

PEACHTREE®

General Ledger . \$399/\$40
Acct Receivable \$399/\$40
Acct Payable . . \$399/\$40
Payroll \$399/\$40
Inventory \$399/\$40
Surveyor \$399/\$40
Property Mgt . . \$799/\$40
CPA Client
Write-up \$799/\$40
P5 Version . . . Add \$129

MISC.

Plastic File Box
50-5 1/4" \$ 19
5 1/2" Library Case \$ 3
8" Library Case . \$ 4
Head Clean Kit . . \$ 23
Floppy Saver . . . \$11.95
Floppy Saver Rings \$ 6.95

TRIBBONS

Radio Shack®
LP 1, 2 & 4 . . . 4 pk \$18.95
LP 3 & 5 . . . 3 pk refill \$13.95
LP 6 & 8 . . . 3 pk refill \$11.95
Daisy Wheel
(black) 10 pk refill \$24.95
(brown, blue or red)
(brown, blue or red) \$24.95
Epson MX-80/& F/T
. 3 pk refill \$16.95

APPLE II

MICROSOFT®

Z-80 Software . . . \$295
RAM card \$155
Basic Compiler . . \$299
Fortran-80 \$175
Cobol-80 \$499
Tasc \$135
Typing Tutor . . . \$ 21
Olympic Decathlon . \$ 25

MICROPRO®

Super Sort 1 . . . \$155/\$36
Mail Merge . . . \$ 85/NA
Word Star . . . \$238/\$36
Word Star/
Mail Merge . . \$319/NA
Calc Star . . . \$155/\$36
Data Star . . . \$225/\$54
Spell Star . . . \$149/NA

PERSONAL SOFTWARE®

Visicalc 3.3 . . . \$155
Visitem \$127
Visiplot \$145
Visidex \$155
Visitrend/Plot . . \$225
Visifile \$195
Desktop/Plan II . . \$155
Visipak \$555

RADIO SHACK

MODEL I & III®

New DOS 180 2.0 . . \$139
LDOS 5.1 \$115
Maxi-Manager . . . \$ 89

GAMES

Adventure International
Big Five . . . 1-5% Off
Avalon Hill . . . 2-10% Off
Med System . . . 3-15% Off
Acorn 5-20% Off
Epyx and Others

MODEL II®

CREATIVE COMPUTER
Depreciation
System \$350/25
Inventory Control \$495/25
Other Acctg. Systems Call
Yahrtzee \$ 24.95

HARDWARE

PRINTERS

Epson MX 100 Call
Epson MX 80FT . . . Call
Epson MX 80 Call
Okidata 809 \$349
Okidata 82A \$489
Okidata 83A \$729
Okidata 84 \$1049
NEC PC8023A . . . \$550
NEC 7710 Call
NEC 7720 Call

MODEMS

Hayes Smart Modem \$245
Hayes Clock-
Cronograph . . . \$235
Lexicon-11 Acoustic \$139
Lexicon-12
Direct/Acoustic . . \$159

MONITORS

Amdek 100 \$139
Amdek 100 Green . . \$155
Amdek Color I . . . \$349
Sanyo 4509 9" . . . \$199
Sanyo 5109 9" Grn . . \$219
Sanyo 6013 13" Color \$419
NEC KB1201 M . . . \$179
NECJC1201 M Color . \$349

TERMINALS

Adds Viewpoint . . \$589
Televideo 910 . . . \$569
Televideo 920C . . . \$739
Televideo 912C . . . \$679
Televideo 950C . . . \$929

Most orders out in 24 hours with VISA, M/C, Money Order, Cashier Check, Bank Wire and C.O.D. Personal check over \$150 allow 10-14 days. Mail order only. Prices subject to change 9-5 M-F, 9-6 Sat.

✓ 190

\$ \$ SAVE \$ \$

**Internal Disk Drives
for the TRS-80® Model III**

1st Disk Kit Includes

- 40 TRK disk drive
- Switching power supply
- Floppy disk controller
- All cables & hardware

ONLY **\$489⁰⁰**

2nd 40trk Disk Drive

ONLY **\$239⁰⁰**

MICRO R&D

P.O. Box 746
Rialto, CA 92376 (714) 875-2968

© Registered Trademark of Tandy Corporation

387

selected or not. The next four bytes are ASCII for the "name" of this value, and the last byte is the binary value. A flag byte of one indicates a selected value and a flag byte of zero indicates an unselected value. An OFFH value indicates the end of the table.

As an example, let's say you normally use a baud of 9600. When you assemble the program, set the flag byte for 300 baud to zero (line 680). Then set the flag byte for 9600 baud to one (line 830). Now when you call the program it will display 9600 instead of 300 for baud and when you press Enter this value will be set for the RS-232 channel. The other tables in the program are arranged similarly and you can change their default values according to your normal operation also.

Subroutine Description

The subroutine starts (line 1290) by displaying the titles and the default values and then goes into a keyboard input loop looking for right-arrow, down-arrow, or Enter characters. Any other input character is ignored. Input of a right-arrow character shifts the underline bar to the next parameter and stores the new parameter selected as a value

between zero and three in the variable PARPTR. Control then returns to the keyboard input loop.

Input of a down-arrow character changes the flag byte of the currently selected value of the currently selected parameter from one to zero and changes the flag byte of the next successive value from zero to one. Also, the new "name" of the value is displayed on the screen in place of the old "name." Control then returns to the keyboard input loop.

Input of an Enter character transmits the current values of all parameters to the RS-232 channel. Program lines 1970-2450 accomplish this and line 2460 exits the subroutine. Lines 2470-3130 are subroutines used by the program.

Model III Version

Model III owners can have a similar subroutine for initializing the built-in RS-232 channel. In the Model III some ROM routines are available to help. The program given in Program Listing 2 provides the same operator interface and uses the Model III ROM routines where applicable. ■

Hugh Cottle designs computer hardware and software for military applications.

ERRATIC DISK DRIVES

RPM measures the rotational speed and variation of your disk drives, and reveals a common cause of unexplained errors. Simple one-key operation, runs under any DOS, interchangeable between Models I and III. Shows current and average speeds, plus fluctuation history. Recovers from severe errors. Documentation explains how to adjust drives. Use RPM monthly for best results. 32-48K Model I or III disk: **\$24.95**

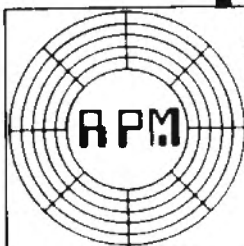

AMAZING PROGRAM SPEEDS UP BASIC

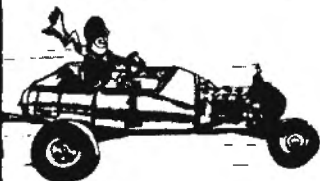

Your time is valuable, so why waste it on slow-running BASIC programs? PRO SOFT's "FASTER" will analyze those programs while they run, then show you a simple change (usually one new line) that can reduce run-times by up to 50%. TRS-80 Models I and III, **\$29.95**

CALL NOW TOLL-FREE FOR ORDERS ONLY:

(800) 824-7888, Oper. 422

Call: (800) 852-7777, Oper. 422

Alaska/Hawaii: (800) 824-7919, Oper. 422

For technical information, write or call us directly:

PROSOFT

P.B. 839 / No. Hollywood, Ca. 91603 / (213) 764-3131

Check, M/C, VISA ok. Add \$2.00 for COD, 6% sales tax in California, and \$5.00 for shipment outside North America.

Program Listing 2

```

00100 *****
00110 ;
00120 ; SUBROUTINE TO SET RS232 PARAMETERS
00130 ; (MODEL III)
00140 ; WRITTEN BY HUGH COTTLE OCTOBER 1981
00150 *****
00160 WHEN CALLED THE CURRENT VALUES OF THE PARAMETERS
00170 ARE DISPLAYED. USE RIGHT ARROW TO SELECT NEXT
00180 PARAMETER; DOWN ARROW TO SELECT NEXT VALUE; PRESS
00190 ENTER AFTER ALL SELECTIONS MADE TO INITIALIZE THE
00200 RS232 CHANNEL AND EXIT THE SUBROUTINE.
00210 ;
00220 ORG 00B00H ;NEAR TOP OF 32K SYS
00230 SETSER JP START
00240 ;
00250 *****CONSTANTS*****
00260 ;
00270 ; ROM ENTRY POINTS
00280 ;
00290 DSP EQU 33H ;CHAR IN A TO SCREEN
00300 KBD EQU 49H ;CHAR IN KYBD TO A
00310 CLRSER EQU 01C9H ;CLEAR SCREEN
00320 ;
00330 ; OTHER CONSTANTS
00340 ;
00350 RARW EQU 09H ;RT ARROW CODE
00360 DARW EQU 0AH ;DN ARROW CODE
00370 ENTER EQU 0DH ;ENTER KEY CODE
00380 TAG EQU 83H ;GRAPHIC CHAR CODE
00390 SPACE EQU 20H ;SPACE CODE
00400 BOUT EQU 029H ;OUT PORT FOR BAUD RATE
00410 POUT EQU 0E0H ;OUT PORT UART PARAMETE
00420 HR EQU 0E8H ;OUT PORT TO RESET UART
00430 VIDEO EQU 3C00H ;START ADDR OF SCRN MEM
00440 ;
00450 ;*****VARIABLES*****
00460 ;
00470 PARPTR DB?B B ;LINK TO ACTIVE PARAMET
ER
00480 2AB0 00480 PAR1PT DEFN BPAR
00490 5BB0 00490 PAR2PT DEFN NPAR
00500 74B0 00500 PAR3PT DEFN SPAR
00510 81B0 00510 PAR4PT DEFN PPAR

```

Program continues

MASTER ELECTRONICS, INC.

Authorized "TRS-80" Dealers - * F-723

CAN SET YOU UP IN A

TRS-80

STATE-OF-THE-ART-COMPUTER

STARTING AT 15% DISCOUNT!

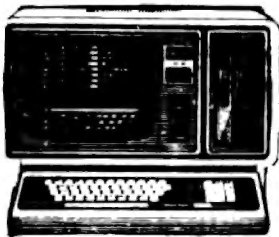

FULLY STOCKED

IN: Model II's

Model III's

ALL-PRINTERS

AND — MORE!!

* PLUS *

THE ALL NEW:

Model 16 and the 8.5 meg. Hard Drive!

CALL US NOW!!!

Toll FREE: 1-800-531-7323

TEXAS CALL COLLECT 512/689-5536



MASTER ELECTRONICS, INC.
154 NORTH 5th
RAYMONDVILLE, TX 78580



✓ 146

ATTENTION UNIVERSITIES AND MEDICAL RESEARCH FACILITIES

DO YOU NEED DETAILED STATISTICAL ANALYSIS?

StatPac is a new 3-part program written and designed for research, survey and questionnaire processing, data entry, statistical analysis, management and market analysis. StatPac can be easily tailored to fit your needs because you create the data file format. All phases of research analysis can be processed, including:

- frequency analysis
- descriptive statistics
- crosstabs & chi-square
- t-test
- correlation and linear regression
- analysis of variance
- multiple linear regression
- management reports

StatPac eliminates the need for expensive programming or renting time on large mainframe computers because it is the SPSS for the TRS-80's.

Total Package, including an extensive step-by-step user's manual is \$285.00. Manual may be purchased separately for \$30.00 (may be applied to the purchase price of the disks). MasterCard and Visa accepted.

Write or call for a FREE 16 page brochure (612) 866-9022.



Walonick Associates, Inc.
5624 Girard Ave. So.
Minneapolis, MN 55419

"Absolutely the best statistical analysis package I've seen for a microcomputer. . . ." Eugene Allred, President of Consolidated Data Services, Minneapolis, MN.

✓ 147

Make Money Selling

80 microcomputing™



the only major journal for the users of the TRS-80*, a sure bet for getting the computer enthusiast into your store. Once through the door you can sell him anything.

We know 80 will make you money. . . it's the only magazine for the TRS-80* users and you know how many of those there are. So call today and join the dealers who make money with 80.

For information on selling 80 Microcomputing, call 603-924-9471 and speak with Ginnie Boudrieau, our Bulk Sales Manager. Or write to her at 80 Microcomputing, Pine Street, Peterborough, NH 03458.

*TRS-80 is a trademark of Tandy Corp.

STOCK MARKET SOFTWARE

By H & H Trading Company for Mod. I, II, & III TRS-80®s

STOCK TRACKER™ times trades on individual stocks and options. Uses a technical volume analysis. Completely objective. Gives buy, sell signals.

MARKET TRACKER™ times tops & bottoms on the Dow Industrials; a composite of six technical indicators. Some judgement required. Gives buy, sell signals.

These two programs are accurate. Hundreds of satisfied users.

ASK FOR THE EVIDENCE!

FOR MORE INFORMATION OR TO ORDER, CONTACT:

H & H TRADING COMPANY

POST OFFICE BOX 549
CLAYTON, CALIFORNIA 94517 ✓ 166
Telephone 415/672-3233
VISA & MASTERCARD

©Regd. T.M. of Radio Shack



THE BIGGEST NAME IN LITTLE COMPUTERS®

**TRS-80™ Model II — Your Best Buy
In a Business Microcomputer**

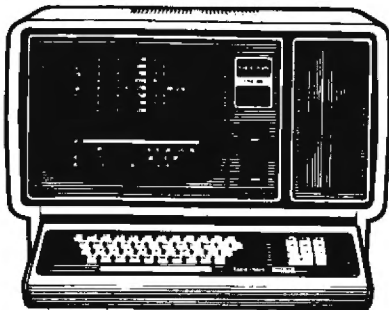

**UP
TO
15%
OFF!**

**TRS-80™ computers, on
software and peripherals**

Similar values on all merchandise
CALL COLLECT:

800-351-1580

Texas Residents call: 915-283-2920

Van Horn Office Supply ✓ 169

701 W. Broadway -- P O Box 1060

Van Horn, Texas 79855

DEALER G055

Form F48 Provided

Standard Warranty in Effect

THE NATIONWIDE SUPERMARKET OF SOUND®

Program continued

```

BB0C 0000 00520 FTSTOR DEFN 0 ;TEMP PTR STORAGE
BB0E 20 00530 BAUD DEFN 0 'BAUD='
BB15 23 00540 NBITS DEFN 0 'BITS='
BB1C 23 00550 SPBITS DEFN 0 'STOP='
BB23 50 00560 PARITY DEFN 0 'PARITY='
00570 ;
00580 ; BAUD RATE TABLE
00590 ; FLAG=0 NOT SELECTED VALUE
00600 ; -1 SELECTED VALUE
00610 ; =BPFH END OF SELECTIONS
BB2A 00 00620 BPAR DEFN 0 ;FLAG
BB2B 31 00630 DEFN '110 ' ;NAME OF SELECTION
BB2F 22 00640 DEFN 22H ;VALUE OF SELECTION
BB30 00 00650 DEFN 0
BB31 31 00660 DEFN '150 '
BB35 44 00670 DEFN 44H
BB36 01 00680 DEFN 1 ;DEFAULT SELECTION
BB37 33 00690 DEFN '300 '
BB38 55 00700 DEFN 55H
BB3C 00 00710 DEFN 0
BB3D 36 00720 DEFN '600 '
BB41 66 00730 DEFN 66H
BB42 00 00740 DEFN 0
BB43 31 00750 DEFN '1200 '
BB44 37 00760 DEFN 77H
BB46 00 00770 DEFN 0
BB49 32 00780 DEFN '2400 '
BB4D AA 00790 DEFN 0AAH
BB4E 00 00800 DEFN 0
BB4F 34 00810 DEFN '4800 '
BB53 CC 00820 DEFN 0CCH
BB54 00 00830 DEFN 0
BB55 39 00840 DEFN '9600 '
BB59 EE 00850 DEFN 0E0H
BB5A FF 00860 DEFN 0FFH ;TABLE END MARKER
00870 ;
00880 ; TABLE OF # BITS PARAMETER
00890 ;
BB5B 00 00900 NPAR DEFN 0
BB5C 35 00910 DEFN '5 '
BB5D 34 00920 DEFN 0
BB5E 00 00930 DEFN 0
BB62 36 00940 DEFN '6 '
BB66 40 00950 DEFN 40H
BB67 00 00960 DEFN 0
BB68 37 00970 DEFN '7 '
BB6C 20 00980 DEFN 20H
BB6D 01 00990 DEFN 1 ;DEFAULT SELECTION
BB6E 38 01000 DEFN '8 '
BB72 00 01010 DEFN 00H
BB73 FF 01020 DEFN 0FFH
01030 ;
01040 ; TABLE OF # STOP BITS PARAMETER
01050 ;
BB74 01 01060 SPAR DEFN 1 ;DEFAULT SELECTION
BB75 31 01070 DEFN '1 '
BB76 00 01080 DEFN 0
BB7A 00 01090 DEFN 0
BB7B 32 01100 DEFN '2 '
BB7F 10 01110 DEFN 10H
BB80 FF 01120 DEFN 0FFH
01130 ;
01140 ; TABLE OF PARITY PARAMETER
01150 ;
BB81 01 01160 PPAR DEFN 1 ;DEFAULT SELECTION
BB82 4E 01170 DEFN 'NONE '
BB86 00 01180 DEFN 0
BB87 00 01190 DEFN 0
BB88 4F 01200 DEFN 'ODD '
BB8C 00 01210 DEFN 0
BB8D 00 01220 DEFN 0
BB8E 45 01230 DEFN 'EVEN '
BB92 00 01240 DEFN 0
BB93 FF 01250 DEFN 0FFH
01260 ;
01270 ; PROGRAM
01280 ;
BB94 CDC901 01290 START CALL CLRSCR
BB97 010700 01300 LD BC,7
BB9A 210E00 01310 LD HL,BAUD
BB9D 11083C 01320 LD DE,VIDEO
BB9E EDB0 01330 LDIR ;DISPLAY BAUD=
BB9F 010700 01340 LD BC,7
BBA5 211500 01350 LD HL,NBITS
BBAB 11103C 01360 LD DE,VIDEO+16
BBAB EDB0 01370 LDIR
BBAD 010700 01380 LD BC,7
BBB0 211C00 01390 LD HL,SPBITS
BBB3 11283C 01400 LD DE,VIDEO+32
BBB6 EDB0 01410 LDIR
BBB8 010700 01420 LD BC,7
BBBB 212300 01430 LD HL,PARITY
BBBE 11303C 01440 LD DE,VIDEO+48
BBC1 EDB0 01450 LDIR
BBC3 CD00BC 01460 CALL DSPVAL
BBC6 3E03 01470 LD A,TAG
BBC8 CD0ABC 01480 CALL DSPUNL
BBCB CD4900 01490 CALL NED
BBCE FE09 01500 CP RARW
BBD0 CADFB0 01510 JP 2,NSEL
BBDJ FE0A 01520 CP DARM
BBD5 CAF5B0 01530 JP 2,NVAL
BBD8 FE0D 01540 CP ENTER
BBDA CA2C0C 01550 JP 2,INITRS
BBDD 10C 01560 JR KYBINF
BBDF 1200 01570 LD A,SPACE ;NEXT PARAMETER
BBE1 CD0ABC 01580 CALL DSPUNL
BBE4 3A03B0 01590 LD A,(PARPTR)
BBE7 3C 01600 INC A
BBE8 E603 01610 AND 3
BBEA 3203B0 01620 LD (PARPTR),A
BBED 3E03 01630 LD A,TAG
BBEF CD0ABC 01640 CALL DSPUNL
BBF2 1C00 01650 LD A,KYBINF
BBF5 3A03B0 01660 NVAL LD A,(PARPTR) ;NEXT VALUE
BBF8 E603 01670 AND 3
BBFA 07 01680 RLCA
BBFB 210400 01690 LD HL,PARPTR+1
BBFE 1000 01700 LD D,0
BC00 5F 01710 LD E,A
BC01 19 01720 ADD HL,DR
BC02 56 01730 LD E,(HL)
BC03 23 01740 INC HL
BC04 56 01750 LD D,(HL)
BC05 EB 01760 EX DE,HL
BC06 220CB0 01770 LD (PTSTOR),HL
BC09 7E 01780 NVAL LD A,(HL)
BC0A FE01 01790 CP 1
BC0C 2000 01800 JP 2,NVLP1
BC0E 110600 01810 LD DE,6
BC11 19 01820 ADD HL,DE
BC12 18F5 01830 JR NVLP
BC14 AF 01840 NVLP1 XOR A

```

Program continues

Program continued

```

BC15 77 01850 LD (BL),A
BC16 1600 01860 LD D,6
BC18 1606 01870 LD E,6
BC1A 19 01880 ADD HL,DE
BC1B 7E 01890 A,(HL)
BC1C FFFF 01900 CP 0FFF
BC1E 2803 01910 JR NE,NVLP2
BC20 2A0CB0 01920 LD HL,(FSTOR)
BC23 38E1 01930 NVLP2 LD A,1
BC25 77 01940 LD (HL),A
BC26 CD00BC 01950 CALL 0SPVAL
BC29 C3C8B0 01960 JP KYBLWP
BC2C 212ABB 01980 INITRS LD HL,BPAR
BC2F 7E 01990 IBRLP1 LD A,(HL)
BC30 F800 02000 CP 0
BC32 2806 02010 JR NE,IBRLP2
BC34 110600 02020 LD DE,6
BC37 19 02030 ADD HL,DE
BC38 18F5 02040 JK IBRLP1
BC3A 110500 02050 IBRLP2 LD DE,5
BC3D 19 02060 ADD HL,DE
BC3E 7E 02070 LD A,(HL)
BC3F 32FA41 02080 (16880),A ;SET BAUD RATE
BC42 8205 02090 LD C,5 ;BIT 2-1 TO EN RS232 OU
T
BC44 2158B0 02100 LD HL,NPAR
BC47 7E 02110 LD A,(HL)
BC48 F800 02120 CP 0
BC4A 2806 02130 JR NE,IUPLP2
BC4C 110600 02140 LD DE,6
BC4F 19 02150 ADD HL,DE
BC50 18F5 02160 JR IUPLP1
BC52 110500 02170 IUPLP2 LD DE,5
BC55 19 02180 ADD HL,DE
BC56 7E 02190 LD A,(HL)
BC57 11 02200 OR C
BC58 4F 02210 LD C,A
BC59 11740B 02220 LD HL,SPAR
BC5C 7E 02230 IUPLP3 LD A,(HL)
BC5D F800 02240 CP 0
BC5F 2806 02250 JR NE,IUPLP4
BC61 110600 02260 LD DE,6
BC64 19 02270 ADD HL,DE
BC65 18F5 02280 JR IUPLP3
BC67 110500 02290 IUPLP4 LD DE,6
BC6A 19 02300 ADD HL,DE
BC6B 7E 02310 LD A,(HL)
BC6C B1 02320 OR C
BC6D 4F 02330 LD C,A
BC6E 2101BB 02340 LD HL,PPAR
BC71 7E 02350 IUPLP5 LD A,(HL)
BC72 F800 02360 CP 0
BC74 2806 02370 JR NE,IUPLP6
BC76 110600 02380 LD DE,6
BC79 19 02390 ADD HL,DE
BC7A 18F5 02400 JR IUPLP5
BC7C 110500 02410 IUPLP6 LD DE,5
BC7F 19 02420 ADD HL,DE
BC80 7E 02430 LD A,(HL)
BC81 B1 02440 OR C
BC82 32FA41 02450 LD A,(16880),A ;SET UART PARAMETERS
BC85 AF 02451 LD A,WOR
BC86 32FA41 02452 LD A,(16890),A
BC89 CD5A00 02453 CALL 005AH ;MOD III REINIT SR
BC8C C9 02460 RET ;EXIT PROGRAM
02470 ;
02480 ; SUBROUTINES
02490 ;
BC8D 110600 02500 LD DE,6
BC90 212ABB 02510 DSPVAL LD HL,SPAR
BC93 7E 02520 BLP1 LD A,(HL)
BC94 F801 02530 CP 1
BC96 2803 02540 JR Z,BLP2
BC98 19 02550 ADD HL,DE
BC99 18F0 02560 JR BLP1
BC9B 23 02570 BLP2 INC HL
BC9C 010400 02580 LD BC,4
BC9F 11073C 02590 LD DE,VIDBO+7
BCA2 E000 02600 LDIR ;DISPLAY BAUD
BCA4 110600 02610 LD DE,6
BCA7 2158B0 02620 LD HL,NPAR
BCAA 7E 02630 NLP1 LD A,(HL)
BCAB F801 02640 CP 1
BCAD 2803 02650 JR Z,NLP2
BCAF 19 02660 ADD HL,DE
BCB0 18F0 02670 JR NLP1
BCB2 23 02680 NLP2 INC HL
BCB3 010400 02690 LD BC,4
BCB6 11173C 02700 LD DE,VIDBO+23
BCB9 E000 02710 LDIR ;DISPLAY #BITS
BCBB 110600 02720 LD DE,6
BCBE 21740B 02730 LD HL,PPAR
BCD1 7E 02740 SLP1 LD A,(HL)
BCD2 F801 02750 CP 1
BCD4 2803 02760 JR Z,SLP2
BCD6 19 02770 ADD HL,DE
BCD7 18F0 02780 JR SLP1
BCD9 23 02790 SLP2 INC HL
BCCA 010400 02800 LD BC,4
BCCD 11273C 02810 DE,VIDBO+39 ;DISPLAY #STOP BITS
BCD0 E000 02820 LDIR
BCD2 110600 02830 LD DE,6
BCD5 2181BB 02840 LD HL,PPAR
BCD8 7E 02850 PLP1 LD A,(HL)
BCD9 F801 02860 CP 1
BCDB 2803 02870 JR Z,PLP2
BCDD 19 02880 ADD HL,DE
BCDE 18F0 02890 JR PLP1
BCD0 23 02900 PLP2 INC HL
BCF1 010400 02910 LD BC,4
BCF4 11373C 02920 LD DE,VIDBO+55 ;DISPLAY PARITY
BCF7 E000 02930 LDIR
BCF9 C9 02940 RET
02950 ;
02960 ;
BCFA 4F 02970 DSPVAL LD C,A
BCFB 3A0300 02980 LD A,(PARPTR)
BCE0 E603 02990 AND 3
BCF0 07 03000 RLC A
BCF1 07 03010 RLC A
BCF2 07 03020 RLC A
BCF3 07 03030 RLC A
BCF4 21403C 03040 LD HL,VIDBO+64
BCF7 1600 03050 LD D,#0
BCF9 5F 03060 LD E,#A
BCFA 19 03070 ADD HL,DE
BCFB 0606 03080 LD B,6
BCFD 79 03090 LD A,C
BCFE 77 03100 UNLLP1 LD (HL),A
BCFF 23 03110 INC HL
BD00 18FC 03120 DJNZ UNLLP1
BD02 C9 03130 RET
BD00 03140 END SETSR
00000 TOTAL ERRORS

```



Micro-Grip™

FRICION FEED FOR YOUR EPSON

MX-70 or MX-80

*MX-70 and MX-80 are Trademarks of EPSON Inc

- Converts your printer for friction feed of SINGLE SHEETS or ROLL PAPER.
- SIMPLE Installation (all you need is a screwdriver, no soldering).
- Tractor feed remains undisturbed.
- Only \$39⁹⁵ (add \$1.50 for postage)



SATISFACTION GUARANTEED OR YOUR MONEY BACK



MICRO-GRIP, Ltd.
P. O. Box 4278
Norton AFB, CA 92409

VISA & Master Card Accepted

✓161



POCKET COMPUTER NEWSLETTER

A NEWSLETTER FOR POCKET COMPUTER USERS

This timely, compact publication provides up to the minute information on pocket computers, including models such as the Radio Shack TRS-80 PC, Sharp Electronic's PC-1211, the Casio FX-702P, Panasonic's RL-H1000, and others as they are announced. We only cover pocket computers that are capable of executing a high level language such as BASIC.

- Up to the Minute News
- Product & Equipment Reviews
- Important Operating Tips
- Practical Programs
- More By Subscription Only: for a calendar year period (January - December). You get all issues published to date for the calendar year in which you subscribe, at the time you subscribe.

MC/VISA Phone Subscriptions: (203) 888-1946

- 1981/82 Charter Subscriber (Issues 1 - 20). \$40.00 in U.S. (U.S. \$48.00 to Canada. U.S. \$60.00 elsewhere.)
- 1982 Regular Subscriber (Issues 11 - 20). \$30.00 in U.S. (U.S. \$36.00 to Canada. U.S. \$45.00 elsewhere.)
- Sample issue. \$3.00 in U.S. (U.S. \$4.00 elsewhere.) *Due to credit card minimum, this item cannot be charged.

Orders must be accompanied by payment in full. We do not issue invoices for the POCKET COMPUTER NEWSLETTER. Thank you for your remittance.

Name: _____
 Addr: _____
 City: _____ State: _____ Zip: _____
 MC/VISA #: _____ Expires: _____
 Signature: _____

POCKET COMPUTER NEWSLETTER
 35 Old State Road, Oxford, CT 06483

✓25

DIS is some idea!

Dynamic Item Scheduling

L. Benjamin Wyckoff, Ph.D.
952 Milledge Place N. E.
Atlanta, GA 30329

A computer is a teacher with infinite patience. Students, however, are impatient. When the student first meets the computer there is a honeymoon period based on the system's glamour and novelty. But after that, the student is impatient with questions he cannot answer. He is also impatient with written explanations which might give him the answers, and even more impatient with questions for which he knows the answer too well.

The programmer faces a neat balancing act. He must provide a program with lots of action,

lots of student participation, and the student must make judgments which are neither too obvious nor too obscure.

Every student is different and the differences are not simply in the level of achievement along some linear scale. Students can easily vary in their mastery of every individual item in the subject matter, independent of other items. These conditions push the task of proper pacing and sequencing almost beyond hope.

The problems are most clearly evident in rote learning or drills. I will illustrate my solution with a spelling lesson, although you can apply the same concepts to the states and their capitals, or the first and last names of your co-workers, or just about any task requiring memorization. (I do not intend to minimize the usefulness of spelling rules, but I am focusing on that part of the task which learning rules do not resolve.)

I will describe an instructional program which continually adjusts the level of repetition of every item with every response by the student. I refer to this procedure as dynamic item scheduling.

Dynamic Item Scheduling

When you are told the correct spelling of a word there is an ideal moment when you should be asked to repeat it. If I ask you again immediately you are justifiably insulted. If I wait too long you have lost it and you are embarrassed. If I come through at exactly the right moment, you are not quite sure but you give the answer and it turns out you are right.

When the laws of teaching are written, one of them will be that guessing right is one of the most significant events in learning. It also feels good. Guessing wrong is not damaging as long as it is interspersed with enough guessing right. Early theories of teaching machines held that you should try for zero mistakes. This approach resulted in painfully boring programs which drove people away.

This spelling program presents the student with words, one after another. He must decide if each word is spelled correctly. If not, he gives his idea of the correct spelling. If his response is wrong, the computer gives the correct spelling immediately. This item is sched-

uled for repetition according to an index of mastery which reflects previous right and wrong responses to that item.

At this point some teachers may be gasping that you must never intentionally expose a student to a misspelled word. However, I believe that students can surmount this hazard and come out with a well-established knowledge of correct spelling. This program's concept does not hinge on this issue. I would use verbal presentation but the resources are not readily available for most readers. This hazard would not come up at all in a task like learning the abbreviations for states.

I derived the computation of the index of mastery through experimentation attempting to hit that ideal moment for repetition. The index is a number controlling the number of words the program will present before repeating this one. On the first error for a particular word, the index is set at 2. It is multiplied by 3 on each correct response and divided by 4 on each incorrect response. The index is not allowed to go below one (it would make little sense), and whenever it gets above 50 the word disap-

The Key Box

Color Basic
Color Computer
16K RAM

pears from the schedule.

Let us consider the initial arrangement of the sequence for the lesson. I considered arranging the words from easy to difficult, but this would have relatively little impact within a lesson. I also expect students to run through this lesson several times, and it is important that sequence should not become a secondary (false) clue to the spelling. For this reason all words in the lesson are arranged in a freshly-scrambled sequence each time the program is run.

How the Program Works

The key to this program lies in the management of sequences in the initial shuffling of the deck, and in the dynamic item scheduling during the session. An array of pointers forming a chain controls sequencing. Each item has a pointer which specifies the location of the item scheduled to follow. Each item carries its own future. To modify the sequence it is only necessary to reset the values of the pointers; the contents of the items need not be moved. This is a well established technique for managing sequences in data base management systems. During initialization the pointers create a logical circle reaching all of the items stored.

The concept is equivalent to a circle of dancers in a folk dance holding hands. Each new item (dancer) joining the circle walks forward from the latest preceding newcomer a random number of positions. Let us say that he arrives at a dancer named Mimi. To break into the chain, the dancer who had been Mimi's "future," now becomes the newcomer's future, and the newcomer becomes Mimi's future. A complete circle is always maintained regardless of the number of items. The random walk may go all the way around the circle, possibly more than once. Curiously, the circle starts out with a single dancer holding her own hand.

The data which the program reads during this process consists of pairs of entries in Data statements. The first member of each pair is the correct spelling

and the second is the incorrect spelling of a word. These two elements are placed in the next available position of the arrays R\$(n) and W\$(n). A future-pointer F(n) is established by the procedure described above, and an initial mastery level M(n) is set to 99. After loading is complete, the exercise starts with the item identified as the future of item 1. (Item 1 is a dummy item which marks the beginning and end of the chain.)

Each trial is selected randomly to be a "positive trial" or a "negative trial" (whether the correct or incorrect spelling will be presented). Negative trials are used three out of four times. If the spelling is correct the student may simply press Enter; otherwise, he must give the correct spelling. Some Basic interpreters do not allow blank lines as input, in which case you should change the program to accept a plus (+) sign instead.

For either type of trial, positive or negative, the student's response may be right or wrong. If the mastery level is under 50 or if the response is wrong, an adjustment is made in the mastery level (as discussed earlier) the program inserts the item into the chain up ahead. This insertion is similar to the original loading except that it is not necessary to maintain the complete circle in the chain. If an item has never been missed and the response is correct, the mastery level is automatically high enough and the item is simply not inserted up ahead. Once an item is missed, the mastery level for dropping it must be earned with right (or wrong) responses. The lesson is complete when you go full circle and come back to the item whose future is item 1.

Final Points

I wrote the program on a TRS-80 Color Computer with 16K. The Basic should cause no difficulty on other Basic systems. The only instructions that might call for modification on other machines are those using the word Sound. These control beeps are incidental to the program's operation and can be omitted. The lines starting with

an apostrophe are remarks which you may omit or change to REM statements.

When the program is running you may enter an asterisk at any point instead of a word and get a listing of the current state of the items, the pointers and the mastery level for each. This will explain more concretely how chaining works. The student would not ordinarily use this.

You can change or add to the Data statements which contain the words to be learned. Make several copies using different sets of words to provide a more

complete course. Be sure to make your entries in pairs, with the correct spelling first in each pair. The program is indifferent to the number of pairs you use as long as you stay within the 100 cells specified in the Dimension statements. New Data statements should precede the end marker DATA ZZZ.ZZZ.■

Mr. Wyckoff is employed by the state of Georgia Department of Offender Rehabilitation as Director of Research and Evaluation. His hobbies are music and writing fiction.

```
3 '-----:
4 'PROGRAM BY:
5 'L. B. WYCKOFF
6 '952 MILLEDGE PLACE
7 'ATLANTA GA 30329
8 '-----:
10 CLEAR 1000
20 DATA NAMELESS,NAMLESS,KNAPSACK,NAPSACK,NARRATIVE,NARATIVE,NAV
IGABLE,NAVIGIBLE,GNAW,KNAW
24 DATA WRESTLER,WRESLER,WIELD,WELD,VITAL,VITLE,VITAMIN,VITMAN
,USUAL,USSAUL,TYING,TIING,TYRANT,TIRYANT,TRIPPING,TRIPING
26 DATA UTILITY,UTILETY,SUGAR,SHUGER,SUPPLY,SUPLY,SURPASS,SERPAS
,COMET,COMMET,GRAVEL,GRAVAL,WHIM,WIM
30 DATA NEBULOUS,NEBULUS,POSSIL,POSIL,PRIVOLOUS,PRIVLOUS,FRUGHT
,FRUGHT,FUGITIVE,FUGATIVE,FULFILL,FULLFIL,FUNNEL,FUNALL
40 DATA BOURBON,BURBON,BURGLARY,BURGULARY,CARAMEL,CARMEL,ANCIENT
,ANTIANT,NIBBLE,NIBLE,NICKEL,NICKLE
50 DATA BARBECUE,BARBEQUE,NAIVE,NIEVE,NINTH,NINETH,NOXIOUS,NOCSO
US,NOTARY,NOTERY,NOTABLE,NOTIBLE,OFFENSE,OFFENCE
60 DATA PASSIVE,PASIVE,PAGEANT,PAGENT,PARROT,PAROT,PESO,PASO,PAT
10,PATTIO,PAVEMENT,PAVMENT,CONCEIVE,CONCIEVE
70 DATA ZZZ,ZZZ
80 DIM R$(100),W$(100),F(100),M(100)
90 F(1)=1:A=1:P=1
92 CLS:PRINT "PLEASE WAIT"
100 ' NEXT LOAD
110 A=A+1:READ RI$:IF RI$="ZZZ" GO TO 170
120 R$(A)=RI$:READ W$(A)
130 X=P
140 B=RND(A)+2:GOSUB 510
150 SOUND 200,2
160 GO TO 100
170 'LOADING COMPLETE
180 CLS:PRINT "IF YOU THINK THE WORD IS WRONG SPELL IT RIGHT.":
PRINT "IF YOU THINK IT IS RIGHT, JUST PRESS ENTER.":PRINT "ENT
ER EXIT TO END LESSON.":PRINT
190 NX=F(1):WG=0:RT=0
200 'NEXT ITEM
210 C=NX:NK=F(C)
220 IF NX=1 GO TO 470
230 RN=RND(100)
240 IF RN>75 GOTO 300'POSITIVE TRIAL
250 PRINT W$(C):INPUT IS
260 IF IS=R$(C) GOTO 350'RIGHT
270 IF IS="EXIT" GO TO 470
280 IF IS="" THEN GOSUB 600: GO TO 250
290 GO TO 390'WRONG
300 PRINT R$(C):INPUT IS
310 IF IS=R$(C) OR IS=""GOTO 350'RIGHT
320 IF IS="EXIT" GO TO 470
330 IF IS="" THEN GOSUB 600:GO TO 300
340 GO TO 390
350 'RIGHT ANSWER
360 RT=RT+1:SOUND 200,1
370 IF M(C)>32 GOTO 200
380 M(C)=M(C)*3:GO TO 440'INSERT
390 'WRONG ANSWER
400 WG=WG+1:SOUND 40,5
410 PRINT " + ";R$(C)
420 IF M(C)=99 THEN M(C)=2: GO TO 440
430 M(C)=M(C)/4:IF M(C)<1 THEN M(C)=1
440 ' INSERT B STEPS AHEAD
450 X=C:B=M(C):GOSUB 560
460 F(C)=F(X):F(X)=C:GO TO 200
470 ' WRAPUP
480 PRINT "LESSON COMPLETE"
490 PRINT RT " RIGHT":PRINT WG " WRONG"
500 END
510 'INSERT AFTER B STEPS
520 B=B-1:X=F(X)
530 IF B>1 GO TO 510
540 F(A)=F(X):F(X)=A:M(A)=99
550 RETURN
560 'WALK B STEPS ALONG CHAIN
570 X=F(X):IF F(X)=1 GO TO 590
580 B=B-1:IF B>0 GOTO 560
590 RETURN
600 FOR J=1 TO A-1:PRINT J:F(J); R$(J):NEXT J
610 RETURN
```

Program Listing

Drive a pantograph with a Model III.

Computerized Engraving

Allan S. Joffe W3KBM
1005 Twining Road
Dresher, PA 19025

Remember the pantograph? It is a simple device consisting of four linked arms carrying a tracing point and pencil. By

carefully tracing a drawing with the tracing point, the pencil end makes an enlarged or reduced copy of the original drawing.

The pantograph concept is also used in the engraving industry. For engraving, the pencil is replaced by a power driven

routing or engraving point. The device works well but has needed both human guidance and a template master.

The advent of the microcomputer eliminated the need to create a physical template master. The computer can create an electrical image of a template and control the engraving process.

I was in a Radio Shack store when a Dahlgren representative, Bob Laird, placed an order for a TRS-80 Model III with 48K memory. I asked to see their operation.

Photo 1 shows the power driven engraving pantograph. The large box in the middle (see close-up Photo 2) houses power supplies reminiscent of the early Altair computers.



Photo 1

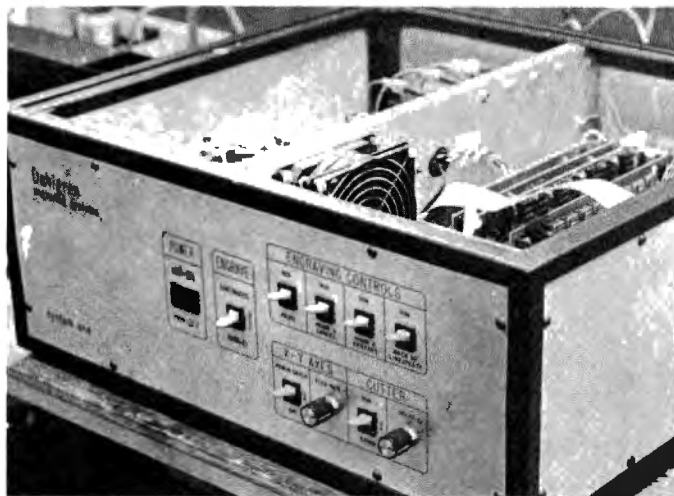

Photo 2

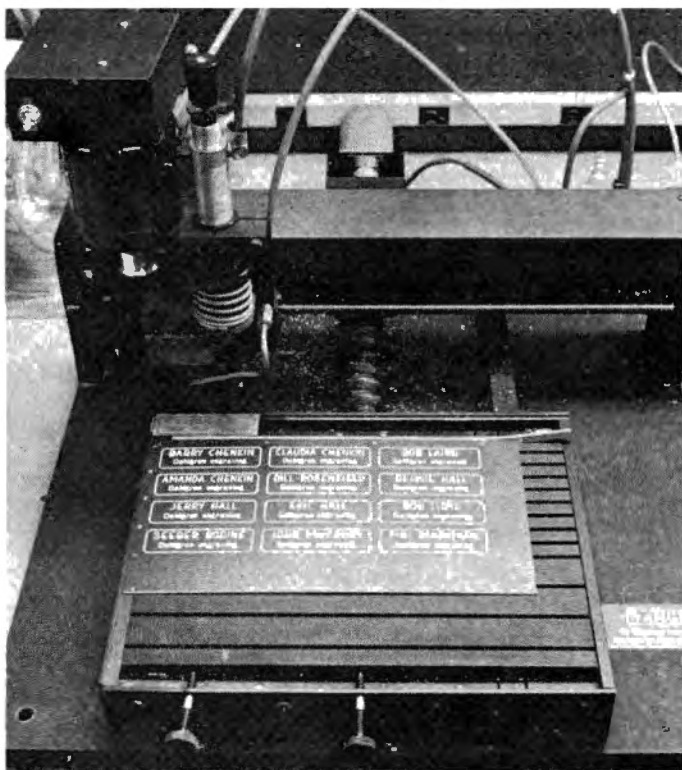

Photo 3

The program is in two parts: A machine language program is loaded first, followed by a long Basic program. The storage medium is cassette, as a DOS system would use too much memory. The loading procedure takes about nine minutes and must be done on each power up.

The computer program accepts the copy to be engraved and allows the selection of type size, letter spacing, number of lines, type font and italics. The computer then sends this information to the auxiliary controls in the middle box. This controls the stepping motors that provide X and Y axis information to the motion of the engraving bit. The system is electrically operated with the single exception of the raising and lowering of the engraving bit. This is done with compressed air under the direction of the program.

The engraving machine can be set to engrave multiple badges or signs on a large work piece (Photo 3). It can also generate

scoring lines for easy separation when the engraving is done. The machine can be programmed to do precision hole cutting or boring.

The only human/machine interface, once the engraving process has started, is removing the finished work and inserting the new blank onto the platen. The system can be used on one piece at a time or on numerous pieces in a row.

The machine also handles graphics. I was shown brass engravings with delicate swirls and patterns using custom programs produced by Dahlgren.

The computer has made reproducibility easier using a system to do quality work without a skilled artisan as the operator.

There is another big plus to having a computer behind the engraving set-up. When not in use for engraving, it can process accounts receivable, control inventory, do billing or any other office chores. It will even play a good game of Star Trek. ■

ACTION GAMES

The fastest growing producer of computer games for your 6809 has the products you have waited for!!

NEW! ARCADE GAMES FOR THE COLOR COMPUTER
CAVE HUNTER COLOR **BERSERK**

Fast paced action • Super Hi-Res Graphics
 Dynamite sound effects • Runs in 16K of memory
 These games will astonish you with their Detail and Quality.
 They set a standard for others to follow.

— ADVENTURES —

Calixto Island • The Black Sanctum

Highly acclaimed by reviewers • Challenging situations
 Fast, efficient machine language • Runs in 16K of memory
 Save game in progress

Adventures on 5 • TSC FLEX disc (specify 6800 or 6809)	ea \$24 95
Both adventures on single disc	\$39 95
Adventures for color computer	ea \$19 95
Color Berserk for color computer	ea \$24 95
Cave Hunter for color computer	ea \$24 95

Enabled these prices for the 6809. Call for all details, please add \$10 tax.



MARK DATA PRODUCTS

23802 Barquilla, Mission Viejo, CA 92691 • (714) 768-1551

TRS 80 IS A TRADEMARK OF TANDY CORP.

SOFTWARE TRS/PMC ONLY UNBEATABLE PRICES!

BUSINESS	DISK LIST/OUR PRICE	CASS LIST/OUR PRICE
Small Business Systems Group		
Accounts Payable (48)	195.00/155.00	n/a
Accounts Receivable (48)	195.00/155.00	n/a
General Ledger (48)	195.00/155.00	n/a
Inventory Control (48)	195.00/155.00	n/a
Payroll (48)	195.00/155.00	n/a
GAMES		
Adventure International		
Armor Patrol	24 95/19 00	19 95/15 00
Barlog - Maces and Magic #1	29 95/23 00	n/a
Conquest of Chestwood	20 95/16 00	19 95/15 00
Earthquake San Francisco 1906 (I)	20 95/16 00	19 95/15 00
Eliminator	24 95/19 00	19 95/15 00
Lunar Lander	20 95/16 00	14 95/11 00
Missile Attack	20 95/16 00	14 95/11 00
Morton's Fork - Maces and Magic #3 (I)	29 95/23 00	n/a
Planetoids	20 95/16 00	19 95/15 00
Scot Adam's Adventure #1 #2 #3	39 95/31 00	n/a
Scot Adam's Adventure #10 #11 #12	39 95/31 00	n/a
Scot Adam's Adventure #4 #5 #6	39 95/31 00	n/a
Scot Adam's Adventure #7 #8 #9	39 95/31 00	n/a
Sky Warrior	20 95/16 00	14 95/11 00
Space Intruders	20 95/16 00	19 95/15 00
Star Fighter	29 95/23 00	24 95/19 00
Star Trek 3.5	15 95/15 00	14 95/11 00
Stone of Sisyphus - Maces and Magic #2 (I)	29 95/23 00	n/a
Big Five		
Attack Force	19 95/15 00	15 95/12 00
Cosmic Fighter	19 95/15 00	15 95/12 00
Defense Command	19 95/15 00	15 95/12 00
Galaxy Invasion	19 95/15 00	15 95/12 00
Meteor Mission	19 95/15 00	15 95/12 00
Robot Attack	19 95/15 00	15 95/12 00
Super Nova	19 95/15 00	15 95/12 00
Cornsoft		
Scarfan	19 95/15 00	15 95/12 00
Space Castle	19 95/15 00	15 95/12 00
INFORMATION PROCESSING		
Adventure International		
Maxi Manager (48)	99 95/79 00	n/a
OPERATING SYSTEMS		
Micro Systems Software		
Dos Plus V3.3 (I)	100 00/80 00	n/a
UTILITIES		
Howe		
MON3 (I)	n/a	39 95/31 00
MON4 (I)	49 95/39 00	n/a
STERM (I)	n/a	69 95/55 00
System Diagnostic	99 95/79 00	n/a
WORD PROCESSING		
Michael Shroyer Software		
Electric Pencil (I)	n/a	100.00/24.00
Aspen Software		
Grammatik (I)	59 00/46 00	n/a
Proof Edit (I)	30 00/23 00	n/a
Proofreader (I)	54 00/42 00	n/a
Soft-Screen (I) (48)	69 00/54 00	n/a
Soft-Text (I) (48)	69 00/54 00	n/a
MISCELLANEOUS		
Adventure 1 thru 12 - Hints Sheets	1 00	
Box of 10 5 1/4-inch Diskettes	25 00	
Box of 10 C-10 cassettes	7 50	
Box of 10 C-20 cassettes	9 00	
Box of 10 C-60 cassettes	11 00	
Box of 10 C-90 cassettes	15 00	

PGMS will run on Mod I • Mod III, 32 DSK or 16K CAS UNLESS Marked.
 (48): 48K DSK • Mod I & III (I): Mod I only (DSK +/-or CAS)

PMCSOFTWARE

✓ 242

475 ELLIS ST., MT. VIEW, CA 94043

Order Only
 Information

CALL (415) 962-0318
 CALL (415) 962-0220

Terms: FOR FAST DELIVERY, send certified checks, money orders, Visa or MasterCard number and expiration date. Personal checks require 3 weeks U.S. sales only. Prices include U.P.S. continental delivery (do not use P.D. Box). CALIFORNIA customers add 6 1/2% tax. Prices subject to change.

It's fun but is it dangerous?

Confessions of a Microholic

Mike Keller
13423 Desert Hills NE
Albuquerque, NM 87111

I used to be a normal person. I slept at night, I ate regularly, and I even watched a little tv. Throughout most of the day I was alert enough to handle tough questions: I knew the day of the week and the President's name. Not any more, though. Not since the microcomputer came into my life.

From the Beginning

When everybody was raving about those wonderful new pocket calculators, I was using a pocket-sized circular slide rule (mostly for price comparisons at the supermarket), and was sure the electronic gadgets would only be a fad—something like the Hula Hoop. After all, my slide rule was smaller, cost only a fraction as much, and had no batteries to run down. Who but an engineer cares if the answer to a problem is 4.5539873224 anyway?

So I held out. The pressure was intense: jeers from my associates, stifled laughter from high-schoolers who thought I was living in the Dark Ages, and quizzical looks from others who did not appreciate the simple elegance of an analog calcula-

tor. Button pushing, however, was fast becoming a national pastime. Digital watches with LED displays were popping up on wrists everywhere. Never mind that these people had to go into a dark closet to read the time, the microelectronic age was upon us. It was only a matter of time before I too would succumb.

I remember the day it happened, as one might remember being struck by lightning. It was a rainy evening late in the year and we decided to window-shop at one of the discount department stores. I was casually looking over the assortment of cameras and pocket calculators when a word on one of the display cards caught my eye—programmable. Then I spotted another word on one of the keys—LRN. Could it be, I wondered, that you can actually teach one of these things to do something? If so, my slide rule was about to take a long vacation.

I had to find out. The clerk handed me the calculator and its instruction booklet, and for the next hour and a half the building could have fallen down around me and I would not have noticed. I remember thinking a little later, "Boy, some holdout. Two hours ago you would not be caught dead with an electronic

calculator, and here you are walking out of a store with one—programmable, no less!" If I was going to be a convert I might as well do it in style. I still could not believe it: in the palm of my hand was a machine capable of learning.

I didn't know it then, but I was about to fall victim to "the fever." That night was a long one, the first of many, but it seemed short. At some time I looked at the clock and it was 2 am. Two o'clock in the morning, and I was just getting started. Little did I realize that this was only the prelude, an appetizer for the frenzy that lay ahead.

After a few weeks with my new electronic companion, I began to realize that it had limitations. I needed more memory registers and the ability to store more keystrokes. The fine distinction between need and want was slowly dissolving.

The Next Step

Then I noticed that the same department store carried the Texas Instruments TI-59, a much more capable machine. One look at the instruction manual convinced me that it would be a long time before I could exhaust its features. It had 60 memory registers, and could remember a sequence of several hundred

keystrokes! In addition, I could feed small magnetic cards through it for permanent storage of programs or data. I did not really know what data was, and the keypad contained functions I had never even heard of, but it is hard to be cold and objective when your mouth is watering.

I still had some contact with reality: A \$230 purchase price was a bit more serious than \$30. Such a decision required more detailed study of the manual (about 2½ hours), and after long minutes glancing back and forth between the calculator and my checkbook, I made what was probably the inevitable choice.

The TI-59 was a good teacher. I began to see mathematics in a whole new light. It was all around me, in the symmetry of a flower, or the harmonics of a guitar string. Shadows cast by a building on a late afternoon became functions of the building's height and the tangent of the sun's angle. Math was an exciting new language to be learned, a unique language not of words, but of symbols and formulas. How could I have missed such a fundamental point in all my years of formal education? What other language could possibly describe the exact path of a basketball on its way to the

hoop? Sure, words could give a glowing description of a beautiful hook shot, but the exact path? It was an awesome realization, like a caveman seeing his reflection in a mirror for the first time. The microtrap was closing around me.

Bigger and Better

A few months later, Radio Shack began advertising a personal computer with a built-in language called Level I Basic. It had 4K of memory—whatever that meant—and represented a price breakthrough at \$599. This was only twice the cost of the TI-59, but was the computer any good? I had shopped at Radio Shack before, but I had some reservations about buying an expensive item there. Confering with a few friends disclosed that I had an outdated image of Radio Shack. Yes, they did carry some low-grade items, but more and more high-class stock was showing up in their catalogues all the time. Maybe this machine was more than just a toy.

Although naive about computers, I knew they must be complex devices. A poorly designed micro would surely be a poor investment. Other manufacturers were selling microcomputers; I would have to be cautious in determining which computer to buy. Which computer? That's right, the question was not *whether* to buy one, but which make and model. I was hooked, and now I knew it.

At the time, personal computers were new on the market. No one really knew how to sell them. Representatives of competing models made me feel stupid. They sprinkled terms like PROM, Eprom, and DMA liberally through their sales pitches. The Radio Shack salesman, on the other hand, spoke plain English. However, they were unable to give anything but vague answers to my specific questions about the machine. I would have to choose a computer without all the information I wanted.

I made my selection as scientifically as possible, based upon product support, availability of maintenance, and pretty pictures in the brochures. Since most manufacturers did not

even have a brochure, I ended up the proud, if somewhat apprehensive, owner of a brand new TRS-80 microcomputer.

When I got the box home the experience of opening it was almost religious. Somehow I sensed this was a red-letter day. In an age when everyone was blaming the computer for billing errors and lost shipments and practically everything else, I was about to get some first-hand experience with one. When I plugged in and saw the screen come to life, I thought of it as the dawn of a new era. Right there on my kitchen counter was an honest-to-gosh computer, up and running!

Using Basic for the first time was a pure joy. I had already read the instruction manual from cover to cover (by now a well-established ritual) and could practically recite the sample programs by heart. My first hands-on experience was marvelous! Basic did practically all the housekeeping for me. No longer did I have to convert each alphabetic character into a number or keep track of the particular memory register where my program had stored a value. I was a kid in a candy store and could not learn this remarkable new machine fast enough.

A Love Affair

In the following months I spent many long hours with the TRS-80 and trust gradually developed. It gave wrong answers because I asked the wrong question, or the right question in the wrong way. The computer was absolutely obedient except when I asked it to do something it could not; even then it was infinitely patient. My little Model I, which had now grown to 16K of memory and spoke Level I Basic, was becoming an extension of me. The video screen was a palate for my thoughts, a place where my problem-solving processes could be shown in black and white. My programs were beginning to show my signature and this fascinating new activity completely captivated me.

As my skills improved I wrote longer and more complicated programs. As the programs became more complex, my

trances became deeper and my lapses of attention to other things (such as putting my left shoe on my left foot) became more frequent. Soon, the obsession began to interfere with everyday events. Why, right in the middle of a sales conference, I might jump up and exclaim, "Of course! It's so simple! I just have to put a GOSUB in line 340."

I was a man possessed. When working on a program, normal activities like eating dinner or shaving became time-devouring annoyances. The ash tray seemed to fill up in seconds, and I lost all sense of time. What could be driving me? How long can a grown man sit in front of a machine whose vocabulary consists of "Ready" or an occasional "syntax error"? Even at the point of physical and mental exhaustion, I was kept helplessly riveted to that keyboard by some invisible force.

Since then it has all been a dizzying downhill ride. I have been the whole ugly route: Disk

Basic, file handling, word processing, you name it. Lately, I have even sunk to new depths. I have been hitting the hard stuff—embedded machine code. I can't get enough of it. My friends shake their heads in dismay. The other day I was almost run down by a moped while concentrating on a troublesome For...Next loop. Sure, it is painful when I hear murmurings behind my back, phrases like "computer junkie," and "they oughtta keep people like that off the streets." But I can't help myself; it has gone too far for me to turn back now.

Well, that's my story. One day I am just like anyone else, and the next thing I know some new technology changes my whole outlook. It is hard to remember what my life was like before the microcomputer. There is not much hope I will ever be normal again; they say my affliction is incurable. I have one question, though: If being a microholic is so terrible, why am I having so much fun? ■

ALL HARDWARE Model I Lowercase
TRS-8000™ CHARACTER GENERATOR

**DUALCASE • ELECTRONIC SHIFT-LOCK • DE-B-BOUNCE
BLOCK CURSOR • SWITCHABLE**

"THE PATCH" is compatible with any word processor, any DOS and also other languages which use ROM sub-routines. Assembled and tested... \$127.00

SCRIPPLUS v3.0 (by ROSTEK) is the software "patch" for SCRIPSIT (c) that lets you output control codes to CHANGE TYPE STYLES, UNDERLINE, etc. from within your text files. Written especially for the MX-80 but works fine with most any printer that accepts control codes. Makes your printer do all the tricks it was designed for: DIR, KILL, MERGE, and MORE. WHILE IN SCRIPSIT (c)

How many times have you wished? Here 'tuz ON DISK 39.95

Need a SUPERFINE lowercase CHARACTER GENERATOR for your MOD 1? KSG Technology builds 'em, and we've got one just for you. Beautiful lowercase-FULL DESCENDERS. All of the graphics, of course. INCLUDES the SPECIAL GRAPHICS for CHR5(0) thru CHR5(31) omitted in the later Radio Shack lower case chips. Ask for the CGA-2. You'll love it! Only 29.95

Did you ever bomb a disk? SUPER UTILITY (by Kim Watt) WILL AUTOMATICALLY RECOVER BOOT SECTIONS, GAT TABLES, READ AND COPY PROTECTED MEDIA, TRANSFER FROM ONE DOS TO ANOTHER, SINGLE OR DOUBLE DENSITY, and on, and on, and on. You just wouldn't believe. Includes a hundred and some odd vital functions. The BEST (no doubt!) and very, very highly recommended for ANYONE that uses a TRS-80 MOD 1 or MOD 3 with any kind of DISK and any kind of DOS. You just got to use it to realize what you've got here! The name "SUPER UTILITY" is a gross under-statement. One use can easily pay for the program. 48K required. Specify 35k, 40k or 80 k media for your Mod 1 or Mod 3. Absolutely professional! You need this! Don't get caught without it! 74.95

The only resource you can't replace is TIME. PLUG IN A SPRINTER (by Holmes Engineering) and

TRIPLE THE SPEED of your TRS-80 MODEL 1 OR MODEL 3.
YES! A NEW Z-80B MICROPROCESSOR IS INCLUDED!
YES! Special circuitry handles your slower memory chips.
YES! Automatic switch down to "normal" for disk I/O.
YES! IT IS ABSOLUTELY FANTASTIC and only 99.50 COMPLETE!!
Only the cream of the crop for you, from HACKS

WHEN ORDERING SPECIFY:
"Mem Size" "Memory Size"

To order send payment plus \$2.00 shipping and handling. Texas residents add 5% sales tax

HACKS
P.O. BOX 12963
Houston, Texas 77017
713-455-3276

National Distributors
for CECDAT, Inc.

What's a coot like him doing in a program like this?

Gabby the Space Cowbum

Richard Ramella
1493 Mountain View Avenue
Chico, CA 95926

"Git 'em, Roy!"

I thought the old coot disappeared forever when the sun set over the cinema desert for the last time and my boyhood Bijou was transmogrified into a western wear emporium.

But no—Gabby Coot lives. I found him the other night tucked away in my TRS-80.

Apparently, when the cheapie westerns died, he somehow blasted off into deep space. He claims he was sidekick to Flash and Buck and tells stories about Scorgons and Trills. He seems to talk about a past yet in my future.

Gabby goes on without stop. It is nearly impossible to shut him up. Even though he invites questions from time to time, don't expect any straight answers.

Talking With Gabby

Gabby is a simple example of generating artificial speech. The program has data lines of seven sentences each with six grammatical elements. These elements are more or less modular. Any of the seven subjects can be appended to any of the seven verbs, or the clauses containing them, and make some degree of sense.

Gabby is capable of spouting more than 5000 sentences. He is evasive and guilty of second

degree yarn spinning and flannel-mouthing.

Gabby can be used as an interesting exercise in creating random "intelligent" patter from alphanumeric data. You can change the data lines to create different characters: a windbag politician promising the moon, a baseball manager explaining his team's cellar status, or humorous nonsense geared to a child's reading level. Remember to use seven sentences of six grammatical elements each. Do not try to compose them on the computer. Do it on paper.

Each of my sentences has an introductory clause, subject, verb, exclamation or similar nonsense and two short clauses with objects.

The Program

Lines 30-340 set and read the alphanumeric data. Line 350 causes a jump ahead if the introductory rigamarole has already been covered in lines 360-430, which respond fairly logically to nearly any answer.

Line 460 determines how many sentences Gabby will spew before a pause. Lines 470-530 select a random element from one of the seven sentences to form a fairly intelligible sentence. Line 540 groups the elements into a string represented by the

single symbol G\$. Line 550 initiates a loop equal to the number of characters in G\$. Line 560 establishes a one-letter string (H\$) equal to successive characters in G\$. Line 570 prints each character in turn.

It may seem puzzling for the program to slice apart sentences and reassemble them. The reasoning is twofold. The move accounts for the fluid appearance of Gabby's words. But, more importantly, it forms the basis for a handy programming trick.

Back up to line 440. In this case the value of O, set initially at zero, will be equal to the progress of the number of characters in a single line appearing on the screen.

Lines 580-590 explain why. Line 580 increments O's value by one each time the loop runs. Line 590 sets two conditions. If the number of characters in a line is more than 55 and the character encountered is a space (" "), the program executes a Print and Gabby continues ruminating on the next line without any broken words at the ends of lines. I find this a useful method for programs whose runs produce lines of unpredictable length.

I have a Radio Shack Line Printer III on which I use 8½

All B westerns had a white-hatted hero and his sidekick, the old coot. This character muttered under his breath when told to stay at the ranch, and steered the hero clear of marriage-minded schoolmarms. At saloon brawls he stood away in a corner and swung his fists wildly at the air while yelling,

The Key Box

Basic Level II
Model I
16K RAM
Line Printer III

```

10 REM * GABBY COOT * BY RICHARD RAMELLA
20 CLS
30 CLEAR 750
40 DATA THEM DAYS THERE WARN'T NO LIGHT SPEED CRUISERS SO
50 DATA THE GANYMEDE FORCES,ATTACKED,BY SIRUI3!
60 DATA SO WE HID BEHIND SATURN'S RINGS
70 DATA IF WE WAS TO GET OUT ALIVE
80 DATA I RECALL THE REAL STORY OF THE BIG METEOR STRIKE OF '89.
90 DATA ME AND FLASH WE,LAY DEAD AHEAD,JUST THEN
100 DATA AND THE GAMMA GENERATOR WAS PLUMB EMPTY
110 DATA AND THAT REALLY GOT THE VENUSIANS RILED UP
120 DATA HAVE YOU HEARD ABOUT THE TRILLS?,BUCK AND THE QUEEN
130 DATA COULDN'T BE FIXED IN TIME,TO STOP THE WAR
140 DATA AND OH IT WAS A TERRIBLE TIME
150 DATA AND IT'S A WONDER I'M HERE TO TELL ABOUT IT
160 DATA REAL EARLY SPACE TIMES?,THOSE SLIME MONSTERS
170 DATA WERE HOT ON THE TRAIL,CONBARN IT
180 DATA AND YES THE SWAMP MEN WERE CLOSER
190 DATA SO WE COULD SYNTHESIZE SOME DILITHIUM
200 DATA AIRLESS AND COLD!,ABOUT A JILLION ASTEROIDS
210 DATA WERE PRETTY CHUMMY,I FIGGERED
220 DATA BUT WE HAD TO DEAL WITH EMPEROR MUNGBEAN FIRST
230 DATA THEN THE WHOLE PLANET'S AXIS MIGHT SHIFT
240 DATA THREE PARSECS OUT OF DIASOL IV,THE BLASTED NOVAS
250 DATA WERE PRETTY CHUMMY,FOR SURE
260 DATA CAUSE WE HAD TO LIFT OFF WITH AN EXTRA BODY ABOARD
270 DATA THEN I COULD REPORT THE MISSION AS COMPLETE
280 DATA WHEN TWENTY TWO-TAILED SCORGONS BARED THEIR FANGS
290 DATA THE BUSTED HOLOGRAM FIELDS,GAVE QUITE A SNOW,YOU BET
300 DATA SO WHEN I KNEW THAT GALAXY WAS A TIMEBOMB
310 DATA THEN ALL CONCERNED COULD GO CRYONIC BY GUR
320 FOR A = 1 TO 7
330 READ A$(A),B$(A),G$(A),D$(A),E$(A),F$(A)
340 NEXT A
350 IF Y = 5 THEN 450
360 PRINT "I'M GABBY COOT. I RECOLLECT THE OLD DAYS IN SPACE."
370 PRINT
380 INPUT "INTERESTED IN HEARING ABOUT THOSE TIMES";B$

```

```

390 CLS
400 V$ = LEFT$(B$,1)
410 IF V$ = "Y" OR V$ = "S" THEN 420 ELSE 430
420 PRINT"GOOD FER YOU, SPACE CADET..": GOTO 440
430 PRINT "WELL, I RECKON I'LL TELL IT ANYWAYS..."
440 O = 0
450 PRINT
460 H = RND(5)
470 FOR I = 1 TO H
480 A = RND(7)
490 B = RND(7)
500 C = RND(7)
510 D = RND(7)
520 E = RND(7)
530 F = RND(7)
540 G$ = A$(A)+" "+B$(B)+" "+C$(C)+" "+D$(D)+" "+E$(E)+" "+F$(F)+" "
550 FOR M = 1 TO LEN(G$)
560 H$ = MID$(G$,M,1)
570 PRINT H$;
580 O=O+1
590 IF O > 55 AND H$= " " PRINT: O = 0
600 NEXT M
610 NEXT I
620 PRINT
630 PRINT
640 O = 0
650 INPUT "ANY QUESTIONS";X$
660 V = LEN(X$)
670 IF V < 5 CLS: RESTORE: GOTO 730
680 V$ = RIGHT$(X$,V/1.5-1)
690 CLS
700 L$ = MID$(V$,1,1)
710 IF L$ = " " PRINT "HOW'S THAT?";V$ ELSE V = V - 1: GOTO 670
720 RESTORE
730 Y = 5
740 GOTO 320
750 END

```

Program Listing 1

inch wide paper. This printer is quite willing to print past the end of my paper. These few lines put a governor on that impulse. Lines 650-740 are no more

than a gambit to continue the endless story. Gabby invites a question, responds "How's that?" and restates a portion of the question asked. It is a con-

versational trick used by people who are not really responding to their listeners. If you modify Gabby to become a politician, using this gambit should make

him seem more realistic. ■
Richard Ramella is a hospital staff writer and has been programming for three years.

CONVERT YOUR SERIAL PRINTER TO PARALLEL

NEW MODEL UPI-3 SERIAL PRINTER INTERFACE MAKES IT POSSIBLE TO CONNECT AN ASCII SERIAL PRINTER TO THE PARALLEL PRINTER PORT ON THE TRS-80.

Software compatibility problems are totally eliminated because the TRS-80 "THINKS" that it has a parallel printer attached. NO MACHINE LANGUAGE DRIVER NEEDS TO BE LOADED INTO HIGH MEMORY BECAUSE THE DRIVER ROUTINE FOR THE UPI-3 IS ALREADY IN THE TRS80 ROM! SCRIPSIT, PENCIL, RSM 2, ST80D, NEWDOS, FORTRAN, BASIC etc. all work as if a parallel printer was in use.

The UPI-3 is completely self contained and ready to use. A 34 conductor edge card connector plugs onto the parallel printer port of the model 1 Expansion Interface or onto the parallel printer port on the TRS-80 III. A DB25 socket mates with the cable from your serial printer. The UPI-3 converts the parallel output of the TRS-80 printer port into serial data in both the RS232-C and 20 MA. loop formats.



SPEEDWAY ELECTRONICS
Division of Binary Devices
11560 TIMBERLAKE LANE
NOBLESVILLE, IN 46060
(317) 842-5020

TRS 80 is a trademark of Fandy

106

VISA MasterCard

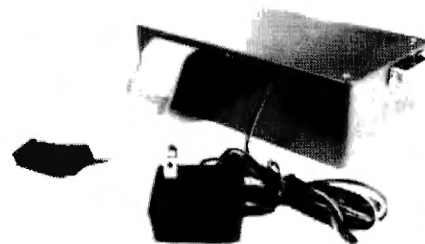

Switch selectable options include:

- Linefeed after Carriage Return
- Handshake polarity (RS232-C)
- Nulls after Carriage Return
- 7 or 8 Data Bits per word
- 1 or 2 Stop Bits per Word
- Parity or No parity
- ODD or EVEN Parity

NOW AVAILABLE FOR MODEL II

UPI-2 for TRS80 Model II	\$149.95
UPI-3 for TRS80 Model I or 3	\$149.95
UPI-4 for use with Model 1 and RS Printer	
Interface Cable (no expansion interface required)	\$159.95
Manual only (may be applied to order)	\$ 5.00
Ten day return privilege — 90 day warranty	
Shipping and Handling on all orders	\$ 4.00
Specify BAUD rate 50-9600 BAUD	

CLOAD problems may be CSAVE problems.

Damping Cassette Output

Ian R. Sinclair
69 Alexandra Road
Sible Hedingham
Halstead, Essex CO9 3NP

When I bought my TRS-80, I did so in light of warnings about its CLOAD problems. Though the TRS-80 was at that time almost unknown in Europe, magazines like *Kilobaud* had enlightened me. I knew what I had to do about the problem (which was the only flaw in a computer otherwise perfect for me).

My new TRS-80 was of dubious ancestry—its Level II 4K keyboard was imported, upgraded to 16K locally, had a 240V power supply attached and some internal modifications made. No CTR-41 or CTR-80 was available, and no monitor. It was the only 16K unit within my price range, around \$900. (The 16K PET cost about \$1600 over here.) Since that day, one phrase in the description has haunted me: The cassette output signal was reduced to avoid CLOAD problems. I did not question the remark at the time.

The keyboard unit suited me fine, because I had a good quality cassette recorder. A modu-

lator supplied with the keyboard enabled me to use a tv receiver in place of a monitor.

Once I found (by trial and error) the correct volume control setting for the cassette replay, I experienced no CLOAD problems. To this day, I use this unit with its cassettes as a reliable backup system for programs and data, though for everyday storage I use the Exatron Stringy-Floppy.

I did not think seriously about CLOAD and CSAVE again until I interfaced a printer to the system (see my "Hard and Soft Printware" article, *80 Microcomputing*, October 1981). I wanted to use the cassette port to drive the interface, but was puzzled to find that the signal was too feeble to operate the interface. Other TRS-80s had no such problems. Measuring the signal voltage at the cassette port confirmed that the strength was much lower than the figure quoted in Radio Shack's hardware manual. I was able to get around the problem with a software fix, as the article describes. At the time I felt this preferable to hardware changes on a system working well for its primary function of CLOAD and CSAVE. With this solved, I once again forgot about the cassette signal.

I had to rethink the problem when I used my TRS-80 for Elec-

tric Pencil text work. (I modified my copy of Pencil so that it gave the stronger cassette port signal that I needed.) After producing a lot of text and recording it on cassette, I went through the slow back-up process by putting in another cassette and recording again. I decided that using two cassette recorders at once would save time. I started some tests to see if I could do this. Paralleling the microphone inputs to two recorders proved to be no problem, and the signal on recorder 1 was unaffected by adding recorder 2. As I expected, there was no simple way of ensuring that I had motor control over recorder 2; I had to operate the key manually. Connecting the motor control cables together does terrible things to the circuits, since separate supplies power each motor.

Problems

The cassette recorded by recorder 2 would not CLOAD when I replayed it on recorder 1. My first guess was that the head azimuth angle of recorder 2 was not the same as that of recorder 1. I set recorder 2 to Replay, removed the earphone plug so that I could listen through the loudspeaker, and then played a cassette recorded on recorder 1. With a small screwdriver inserted through the hole above

the recording head, I adjusted the screw controlling the head angle until the note I heard was sharp and clear, with maximum treble. Recorder 2 needed a very small adjustment, indicating that the head angle had been about right. The adjustment made no difference to the problem—the tapes from machine 2 simply would not CLOAD on machine 1!

The recording volume control setting is automatic with modern cassette recorders—the signal is converted into dc and the dc regulates amplification. The signal sent to the tapehead is never large enough to cause a distorted recording. Like all automatic circuits, however, this type has a limited range, different for each different make of recorder. If a signal input is too large for the automatic recording circuits, distortion results. Did the signal from my TRS-80 overload the automatic recording circuits of the second cassette recorder?

I constructed a miniature volume control between a socket and a jack plug so that I could plug the output from the computer into the volume control, and the output from the volume control into the recorder. I set the volume control halfway, and saved a short program on recorder 2. This one CLOADed on recorder 1, but only when the

replay volume was set lower than normal. I adjusted the volume control on the CSAVE circuit to a lower setting and was able to CSAVE tapes which would CLOAD on recorder 1 at the same settings used for tapes which I had recorded on recorder 1.

I made the change permanent, and have used the system ever since—I backed up the text of two books this way, and I can take text from either cassette with no adjustments.

CLOAD or CSAVE?

How many CLOAD problems are really CSAVE problems, caused by overloading the recording circuits? I would expect that the TRS-80's normal signal would not overload the recording circuits of the CTR-80, but you might try reducing the recording volume if you ever have CLOAD problems. (The signal from the TRS-80 is large enough to override the automatic volume control circuits of most recorders I have tried.)

Dealing with the problem this way means that you do not have to alter the TRS-80, since you can wire the additional volume control outside the case. You can also incorporate the new volume control inside the TRS-80 case, or even inside the recorder's case. If you use a second recorder for quick backups you will need the volume control unless the second recorder is another CTR-80.

My TRS-80 was already modified to produce a smaller cassette output signal. What would my experiences be if it had not been altered? ■

Ian Robertson Sinclair was born in 1932 in Tayport, Scotland, and educated at Madras College, St. Andrews. He started writing articles for magazines in 1964 and began teaching college in 1966. Writes Sinclair, "I bought a TRS-80 whenever a keyboard became available over here (to English TV standards) and have eaten, drunk and slept TRS-80 computing ever since."

COMPUTERWARE
PRODUCTS FOR

COLOR COMPUTER

GAMES • Arcade Graphics
Strategy Adventure • Invaders
Pac Attack • Storm • Magikube
Space Master • Berserk • Maze Race
Galixto Island • Black Sanctum

HOME & WORK • Checkbook • Finance
Word Processing • Color Data Organizer
CAD Drawing Board • Mailing List

PROGRAMMER AIDS • PASCAL • Diagnostics
Editor • Assembler • Monitor

16K + Memory Expansion to 32K
from 4K to 64K Memory Expansion

Books • Supplies
Printers • Modems • Accessories

Cassette and diskette products

Shipping from stock

Call or write:
COMPUTERWARE
Dept. C • Box 888
Encinitas, CA 92024 • (714) 438-3512

Computerware is a trademark of Computerware.

101 USES FOR A DEAD MICROCOMPUTER

no.9

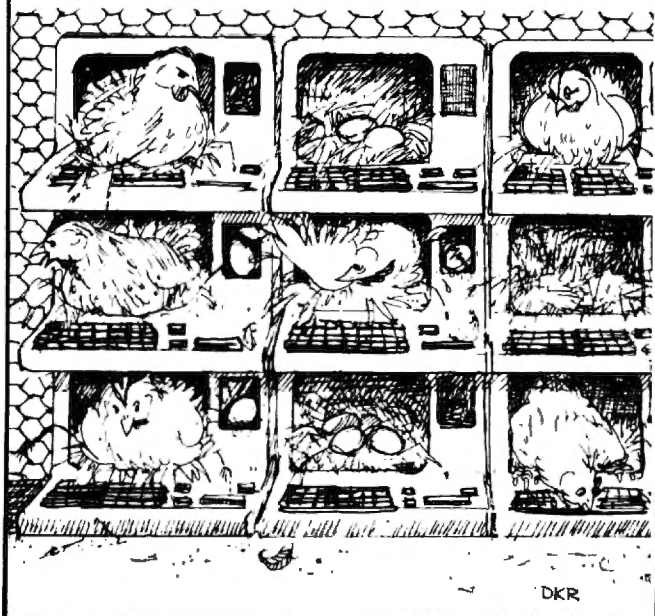

See List of Advertisers on page 354

Some things are just naturally right.



Now on TRS-80
Model I
Disk

tiny-c is a structured programming language designed to give BASIC programmers experience in structured programming concepts. Structured programming brings a different way of thinking to a software project. Tiny-c is the natural step up from BASIC towards this different way. Once you've made the transition, you are ready for any modern structured language, such as C or PASCAL. tiny-c, the structured programming trainer. tiny-c ONE now on disk for the TRS-80 model I, \$100.

tiny c associates, P.O. Box 269, Holmdel, NJ 07733
(201) 671-2296

You'll quickly discover tiny-c is naturally right for your language needs.



527
New Jersey residents include 5% sales tax. Visa or Master Charge accepted, include charge plate number with order.
• TRS-80 is a trademark of Tandy Corp.
• tiny-c is a registered trademark of tiny-c associates.



Compound interest, annuity, amortization and more!

Financial Wizard

Charles R. Perelman
9777 Wilshire Boulevard
Suite 700
Beverly Hills, CA 90212

How much do I need to put into a term savings account now to have \$20,000 for my son's college fund in five years? What will the balloon payment be in three years on my second mortgage? If I buy a bond for 74 which matures in eight years, what will be my yield to maturity?

For family and business financial planning, clients constantly ask questions for which you must use compound interest, annuity, amortization and similar

tables or formulas to make appropriate decisions. Financial Wizard is a practical, easy program which gives immediate calculation of required answers to these types of questions.

Financial Wizard is written in CBasic 2 for the TRS-80 Model II. You can readily convert the program to Radio Shack's Basic. Descriptive variable names help self-document the program. Each major type of operation is a separate module clearly described with remarks. You can put any module into one of your programs as a subroutine. Screen or hardcopy printout of detail is optionally available. Error trapping is provided for neg-

ative numbers, payments insufficient to amortize loans, and other common entry errors. The menus are simple for inexperienced personnel to use. After each routine, you can run it again, try another routine in the same group, return to the main menu or end the program.

Deposit Programs

Planning often requires accumulation of a sum of money. With the deposit routines you can determine the amount which will accumulate from a single deposit at compound interest.

Alternatively you can compute the required amount to deposit, interest rate or time to reach your specific goal. You can use this program to figure the funds available for your child's college expenses from putting a sum in a savings account until he reaches college age.

Annuity Computations

These routines furnish you the results of making a series of deposits. If you save the same amount each year in your Individual Retirement Account, you can compute your nest egg at re-

Your estate is valued at \$500,000. If it increases at eight percent a year, what will be the value six years from now in 1987 when the new estate tax limits go into effect? (Compound Interest menu option 1)

A deposit of \$500,000.00 compounded once a year at interest of 8.00% will be worth \$793,437.16 at the end of 6.0 years.

End of Period	Balance
1	\$540,000.00
2	\$583,200.00
3	\$629,856.00
4	\$680,244.48
5	\$734,864.04
6	\$793,437.16

Example 1

You are 55 years old. You will contribute \$7500 a year to your Keogh plan on January 2 of each year from 1982 through 1991. Invested at 12 percent per annum, how much will you have when you retire Jan. 2, 1992? (Annuity menu option 1)

Deposits of \$7,500.00 once a year at interest of 12.00% will be worth \$147,409.37 at the end of 10.0 years.

End of Period	Balance
1	\$8,400.00
2	\$17,808.00
3	\$28,344.96
4	\$40,146.36
5	\$53,363.92
6	\$68,167.59
7	\$84,747.70
8	\$103,317.42
9	\$124,115.51
10	\$147,409.37

Example 2

tirement. Other options will give you the time, interest rate or deposits required to reach your specified goal.

Add-on Interest

Can you afford to buy that new printer or disk drive? By changing the terms, down payment or payment period, you can determine how to bring the payments within your budget. This routine computes annual percentage rate to compare with other means of financing.

Interest on Reducing Balance

You will get a schedule of payments with interest computed on the remaining balance of principal. Substituting different terms reveals the effect upon monthly payments.

Amortization Tables

With these flexible routines, you can choose any number of payments a year and determine the periodic payment required or print out the complete amortization table. You can find the balance at any point in the life of the loan. For example, if you buy property with a note requiring periodic payments for a number of years and then a balloon, you

can compute the balance when the balloon is due and figure the payments on a new loan assumed to be needed to refinance the balloon payment. As an alternative, you can choose a payment other than that required for equal amortization and obtain a schedule of payments or balance determination. This would show you the effect of making additional principal payments each period. You can vary payments, interest rates and terms to structure a deal to make economic sense.

Yield Computations

Dealing in trust deed notes has been popular in California and elsewhere for some time. One yield routine enables you to determine the amount to pay for an existing note to obtain the interest yield you require when payments include principal amortization. Another routine enables you to determine the price to pay if you purchase a bond or interest-only note. You can also calculate yield to maturity for a note or bond offered at a specific market price.

Examples 1-7 illustrate some of the practical uses for the program.

Your new car will cost \$11,000. After a \$3000 down payment the bank will finance the balance at 12 percent add-on interest. What will the payments and APR be for 36 months? For 48 months? (Add-on menu option 1)

Purchase of item at cost of \$8,000.00
at 12.00% add-on interest
for 36 months
Monthly payment will be \$302.22
Annual percentage rate is 21.20%

Purchase of item at cost of \$8,000.00
at 12.00% add-on interest
for 48 months
Monthly payment will be \$248.67
Annual percentage rate is 20.76%

Example 4

Program Construction

The main menu offers you any of the six types of computation routines or exit from the program. Each program other than the installment payments with interest on balance due has options. CBasic uses double precision numbers for computation, so the results are very accurate.

The screen printout pauses after each screenful of data for your review. This gives you time

to copy any detail data you desire from the screen. There are no pauses in the printer routine so you need sufficient paper for printing all of the entries in long tables.

A repetitive trial and error method calculates the annual percentage rate for add-on installment purchases. This method determines the rate within the limits required by federal regulation Z for consumer financing. The yield on purchase of notes or bonds at a discount

If you draw out \$12,000 each six months from the retirement fund accumulated in Example 2, how long will it last you? (Loan amortization menu option 2)

A loan of \$147,409.37 with payments two times a year at interest of 12.00% each payment \$12,000.00 requires payments for 11.5 years last payment will be \$11,116.96

Period	Principal	Interest	Balance
1	\$3,155.44	\$8,844.56	\$144,253.93
2	\$3,344.76	\$8,655.24	\$140,909.17
3	\$3,545.45	\$8,464.55	\$137,363.72
4	\$3,758.18	\$8,241.82	\$133,605.54
5	\$3,983.67	\$8,016.33	\$129,621.87
6	\$4,222.69	\$7,777.31	\$125,399.19
7	\$4,476.05	\$7,523.95	\$120,923.14
8	\$4,744.61	\$7,255.39	\$116,178.53
9	\$5,029.29	\$6,970.71	\$111,149.24
10	\$5,331.05	\$6,668.95	\$105,818.19
11	\$5,650.91	\$6,349.09	\$100,167.28
12	\$5,989.96	\$6,010.04	\$94,177.32
13	\$6,349.36	\$5,650.64	\$87,827.96
14	\$6,730.32	\$5,269.68	\$81,097.64
15	\$7,134.14	\$4,865.86	\$73,963.49
16	\$7,562.19	\$4,437.81	\$66,401.30
17	\$8,015.92	\$3,984.08	\$58,385.38
18	\$8,496.88	\$3,503.12	\$49,888.51
19	\$9,006.69	\$2,993.31	\$40,881.82
20	\$9,547.09	\$2,452.91	\$31,334.73
21	\$10,119.92	\$1,880.08	\$21,214.81
22	\$10,727.11	\$1,272.89	\$10,487.70
23	\$10,487.70	\$829.26	\$0.00

Note: Last payment is required payoff at end of loan.

Example 3

NEW
40 TRACK
DISK DRIVES
with
POWER SUPPLY & CASE
for
RADIO SHACK
and
OTHER COMPUTERS

 **\$179** 

OMNITEK Computers
International, Inc.

LIMITED SUPPLY **LIMITED SUPPLY**

1899 Main Street
Tewksbury, MA 01876
(617) 851-4580

Shipping extra FOB Tewksbury
Master Card, Visa, or Bank Checks accepted

195

QUALITY WHOLESALE COMPUTER PRODUCTS



Diskettes \$190.00
10 boxes of 10

Individually certified 5¼" double density, soft sector, single sided with hub rings.

LNW Research Computers

Totally TRS-80 compatible, high speed processor, 8" or 5¼" drives, double or single density. . .dealer pricing available.

Now Available.

125K CP/M - Team computer, compatible with TRS-80 Model I and CP/M

CABLES

	Unit Price	Unit Price
	Quantity 10	Quantity 100
2 drive disc drive cable	\$19.29	\$17.54
3 drive disc drive cable	\$26.00	\$23.50
4 drive disc drive cable	\$28.96	\$26.33
8" Extender (disc drive)	\$ 9.98	\$ 8.98
6 ft. printer cable	\$15.40	\$14.00
10 ft printer cable	\$17.79	\$16.17

Custom cables available
Minimum order 10—Call for prices

DISC DRIVE CABINETS

1 drive cabinet	\$51.20	\$44.00
w/power supply		
2 drive cabinet	\$57.82	\$50.00
w/power supply		
—IBM type Horizontal Design		
—Does not require extender cable		

**TANDON 40 TRACK
DOUBLE DENSITY BARE DRIVE ... \$195.00**
Minimum Quantity 10

**U.P.S. Shipping
\$5.00 per order shipping and handling**
wholesale orders only,
minimum 10 pieces.

**Syntax Beta
corporation**

601 Lipan Street
Denver, Colorado 80204
(303) 892-6986 ✓ 10

**Manufacturers and Wholesale Distributors
of Quality Computer Products.**

is figured by approximating and interpolating the difference between approximations.

In CBASIC, the backslash (\) is a line continuation character. CONCHAR% functions similar to INKEY\$ in Radio Shack Basic, returning the ASCII decimal representation of a keyboard entry. The subroutine at line 2200 causes all PRINT commands to go to the line printer rather than the screen.

With this powerful series of programs, you will have the an-

swers at your fingertips for many of the commonly needed calculations for sound financial planning. You will save time and effort and give your clients faster and more efficient service. Planning ahead with these tools will help you and your clients to have a happy, healthy and successful financial future. ■

Charles R. Perelman is an attorney-CPA specializing in tax, estate planning and corporate law in Beverly Hills, CA.

Program Listing

```

REM -----
REM FINANCIAL WIZARD
REM BY CHARLES R. PERELMAN
REM INTEREST, PAYMENT AND LOAN ANALYSIS
REM WRITTEN IN C BASIC2
REM -----
DIN AS(20)
ES="*****"
AS(1)="ENTER THE FOLLOWING INFORMATION (NO COMMAS IN NUMBERS PLEASE):"
AS(2)="WHAT IS THE AMOUNT YOU WILL DEPOSIT? $"
AS(3)="WHAT IS THE AMOUNT YOU WANT TO ACCUMULATE? $"
AS(4)="WHAT INTEREST RATE (E.G. FOR 10.75% ENTER 10.75)?"
AS(5)="HOW MANY YEARS?";AS(6)="NUMBER OF TIMES PER YEAR?";
AS(7)="IF YOU WANT TO PRINT RESULTS, TURN ON PRINTER AND PRESS P."
AS(8)="PRESS ANY OTHER LETTER TO CONTINUE WITHOUT PRINTOUT."
AS(9)="*** PLEASE PRESS NUMBER FOR ROUTINE YOU WISH TO USE ***"
AS(10)="WHAT IS THE COST OF THE ITEM WITHOUT INTEREST? $"
AS(11)="HOW MANY MONTHS?"
AS(12)="PROGRAM PRINTS BALANCE AT END OF EACH PERIOD."
AS(13)="IF YOU WANT TO PRINT DETAILS TO SCREEN, PRESS S."
AS(14)="PRESS ENTER TO CONTINUE LISTING."
AS(15)="TIMES A YEAR AT INTEREST OF "
AS(16)="*** ALL FIGURES MUST BE GREATER THAN 0. PLEASE ENTER AGAIN. ***"

10 PRINT CHR$(12) REM MAIN MENU
PRM RS: FINANCIAL WIZARD ;ES: PRINT:PRINT "MAIN MENU: ";AS(9):PRINT
PRINT 1. ONE DEPOSIT TO SAVINGS ACCOUNT - Compound Interest
PRINT 2. DEPOSIT OF A CERTAIN AMOUNT EACH PERIOD - Annuity
PRINT 3. BUYING ON INSTALLMENTS - Add On Interest, Rental Payments
PRINT 4. BUYING ON INSTALLMENTS - Equal Principal Payments Plus Interest
PRINT 5. AMORTIZED LOANS - Payment tables
PRINT 6. BUYING LOANS FOR A CERTAIN YIELD -Calculating Effective Yield
PRINT 7. END PROGRAM
20 YZ=CONCHAR
IF YZ=(32) THEN 20
IF YZ=(49) OR YZ=(55) THEN PRINT CHR$(12):\
PRINT"PRESS NUMBER FROM 1 TO 7 PLEASE:"\
FOR I=1 TO 500:NEXT X:GOTO 10
CHOICE=YZ-48:ON CHOICE GOTO 100,200,300,400,500,600,5000

100 PRINT CHR$(12) REM COMPOUND INTEREST MENU
PRINT "ONE DEPOSIT TO A SAVINGS ACCOUNT -COMPOUND INTEREST:PRINT
PRINT"1. DEPOSIT OF A SPECIFIC AMOUNT AT GIVEN INTEREST RATE FOR CERTAIN TIME."
PRINT "AS(12)
PRINT"2. AMOUNT TO BE DEPOSITED TO REACH GOAL AT END OF PERIOD AT GIVEN
PRINT" INTEREST RATE. ";AS(12)
PRINT"3. INTEREST RATE REQUIRED FOR DEPOSIT TO REACH GOAL AT END OF CHOSEN
PRINT" PERIOD. COMPUTE RATE. ";AS(12)
PRINT"4. TIME NEEDED TO REACH GOAL FOR DEPOSIT AT SPECIFIED INTEREST RATE."
PRINT" COMPUTES TIME. ";AS(12):PRINT:PRINT AS(9):GOSUB 2000
150 PRINT CHR$(12):PRINT:PRINT AS(1) REM COMPOUND INTEREST INPUT
IF CHOICE<2 THEN PRINT AS(2):INPUT "PRINCIPAL
IF CHOICE<3 THEN PRINT AS(3):INPUT "SUM
IF CHOICE<4 THEN PRINT AS(4):INPUT "INTEREST
IF CHOICE<5 THEN PRINT AS(5):INPUT "YEARS
PRINT"COMPOUNDED FOR WHAT?";AS(6):INPUT "TIMES
IF CHOICE<2 OR CHOICE<3 OR CHOICE<4 AND SUM<0 OR CHOICE<3\
AND INTEREST<0 OR CHOICE<4 AND YEARS<0 OR TIMES<0 THEN\
PRINT:PRINT AS(16):FOR X=1 TO 300:NEXT:PRINT CHR$(12):GOTO 150
IF CHOICE<3 AND SUM<PRINCIPAL OR CHOICE<4 AND SUM<PRINCIPAL THEN PRINT:\
PRINT"*** AMOUNT TO ACCUMULATE MUST EXCEED DEPOSIT. PLEASE REENTER. ***:\
FOR X=1 TO 500:NEXT:PRINT CHR$(12):GOTO 150
N=YEARS/TIMES:INTEREST/(TIMES*100) REM INTEREST COMPUTATIONS
IF CHOICE=1 THEN SUM=PRINCIPAL*(1+R)^N
IF CHOICE=2 THEN PRINCIPAL=SUM*(1+R)^(-N)
IF CHOICE=3 THEN INTEREST=100*TIMES*((SUM/PRINCIPAL)^(1/N))-1
IF CHOICE=4 THEN YEARS=(LOG(SUM/PRINCIPAL)/LOG(1+R))/TIMES
PRINT CHR$(12) REM COMPOUND INTEREST PRINTOUT
151 PRINT ES:PRINT PRINT"A DEPOSIT OF ";PRINT USING D$;PRINCIPAL
PRINT"COMPOUNDED ";TIMES;"TIMES A YEAR AT INTEREST OF ";
PRINT USING R$;INTEREST:PRINT" WILL BE WORTH ";PRINT USING D$:SUM
PRINT"AT THE END OF ";PRINT USING Y$;YEARS:PRINT" YEARS.":PRINT ES:PRINT
IF FLAG=0 THEN GOSUB 2100
IF FLAG=0 THEN 152
PRINT:PRINT"END OF PERIOD";TAB(21);"BALANCE" REM TABLE PRINTOUT
N=YEARS/TIMES:R=INTEREST/(100*TIMES)
FOR X=1 TO X
IF FLAG=1 AND X/22=INT(X/22) THEN PRINT AS(14):INPUT "LINE 25:PRINT
PRINT TAB(6);X;TAB(14):PRINT USING D$:PRINCIPAL*(1+R)^X;NEXT X
IF CHOICE=4 AND YEARS=INT(YEARS)THEN PRINT TAB(6);X:\
TAB(14):PRINT USING D$:SUM:PRINT\
PRINT"NOTE: LAST PERIOD MAY BE PARTIAL PERIOD AND MAY DIFFER FROM"
PRINT"YEARS SHOWN ABOVE AS RESULT OF ROUNDING OFF."
IF FLAG=2 THEN CONSOLE:FLAG=0:GOTO 153
152 GOSUB 2200
IF FLAG=2 THEN 151
153 GOSUB 2300
PRINT CHR$(12):ON PTCK GOTO 150,100,10,5000

200 PRINT CHR$(12) REM ANNUITY MENU
PRINT"SAVING A CERTAIN AMOUNT EACH PERIOD - ANNUITY:PRINT
PRINT"1. TOTAL ACCUMULATION BY DEPOSIT OF SAME AMOUNT AT BEGINNING OF"
PRINT"EACH PERIOD AT GIVEN INTEREST RATE FOR SPECIFIED PERIOD. "
PRINT "AS(12)
PRINT"2. AMOUNT TO DEPOSIT EACH PERIOD AT GIVEN INTEREST RATE FOR SPECIFIED"
PRINT"PERIOD TO REACH GOAL. ";AS(12)
PRINT"3. PAYMENTS YOU WILL RECEIVE AT END OF EACH PERIOD FOR NUMBER OF "
PRINT"PERIODS YOU CHOOSE IF YOU INVEST A LUMP SUM AT SPECIFIED INTEREST RATE."
PRINT"COMPUTES PAYMENT AMOUNT. ";AS(12)
PRINT"4. AMOUNT YOU MUST INVEST NOW AT GIVEN INTEREST RATE TO BE ABLE TO "
PRINT"RECEIVE PAYMENT AT END OF EACH PERIOD FOR SPECIFIED LENGTH OF TIME. "
PRINT"COMPUTES AMOUNT REQUIRED. ";AS(12):PRINT:PRINT AS(9):GOSUB 2000
250 PRINT CHR$(12):PRINT AS(1) REM ANNUITY INPUT
IF CHOICE=1 THEN PRINT"RACH PERIOD ";AS(2):INPUT "
PRINT
IF CHOICE=2 THEN PRINT AS(3):INPUT "
PRINT
IF CHOICE=3 THEN PRINT AS(4):INPUT "DEPOSIT
IF CHOICE=4 THEN PRINT\

```

Program continues

Program continued

```

WHAT IS THE PAYMENT YOU WISH TO RECEIVE EACH PERIOD? $:;INPUT "";:RENT
PRINT AS(4);:INPUT "";:INTEREST
IF CHOICE <= 3 THEN PRINT AS(5);:INPUT "";:YEARS
IF CHOICE = 3 THEN PRINT "PAYMENTS TO BE MADE":AS(5);:INPUT "";:YEARS
IF CHOICE=1 OR CHOICE=2 THEN PRINT "YOU WILL MAKE DEPOSITS WHAT":AS(6);:
INPUT "";:TIMES
IF CHOICE=3 OR CHOICE=4 THEN PRINT "YOU WILL GET PAYMENTS WHAT":AS(6);:
INPUT "";:TIMES
IF CHOICE=1 AND RENT<=0 OR CHOICE=2 AND VALU<=0 OR CHOICE=3 AND DEPOSIT<
<=0 OR CHOICE=4 AND RENT<=0 OR INTEREST<=0 OR YEARS<=0 OR TIMES<=0
THEN PRINT:PRINT AS(16);:FOR X=1 TO 500:NEXT:PRINT CHR$(12);:GOTO 250
N=YEARS*TIMES;:INT=X/(100*TIMES) REM ANNUITY COMPUTATIONS
A=(1+R)*(N+1);:B=(1+R)*(-N)
IF CHOICE=1 THEN VALUE=RENT*(A-(1+R))/R
IF CHOICE=2 THEN RENT=VALUE/((A-(1+R))/R)
IF CHOICE=3 THEN RENT=DEPOSIT/((1-R)/R)
IF CHOICE=4 THEN DEPOSIT=RENT*((1-R)/R)
PRINT CHR$(12) REM ANNUITY PRINTOUT
251 PRINT X$:PRINT
IF CHOICE=1 OR CHOICE=2 THEN PRINT "DEPOSITS OF":PRINT USING D$;RENT
IF CHOICE=3 OR CHOICE=4 THEN PRINT "PAYMENTS OF":PRINT USING D$;RENT
PRINT "TIMES":TIMES A YEAR AT INTEREST OF:PRINT USING R$;INTEREST
IF CHOICE=1 OR CHOICE=2 THEN PRINT "WILL BE WORTH":PRINT USING D$;VALU<
PRINT "AT THE END OF":PRINT USING Y$;YEARS;:PRINT "YEARS."
IF CHOICE=3 OR CHOICE=4 THEN PRINT "FOR":PRINT USING Y$;YEARS;:
PRINT "YEARS":PRINT "WILL REQUIRE AN INITIAL INVESTMENT OF":
PRINT USING D$;DEPOSIT
PRINT X$:PRINT
IF FLAG=0 THEN GOSUB 2100
IF FLAG=0 THEN 252
PRINT:PRINT "END OF PERIOD":TAB(18);"BALANCE" REM TABLE PRINTOUT
B=INTEREST/(100*TIMES);:N=YEARS*TIMES
FOR X=1 TO N
IF FLAG=1 AND X/22=INT(X/22) THEN PRINT AS(14);:INPUT "";:LINE Z$:PRINT
IF CHOICE=1 OR CHOICE=2 THEN
PRINT AS(14);:X;:TAB(14);:PRINT USING D$;RENT*((1+R)*(X+1)-(1+R))/R
IF CHOICE=3 OR CHOICE=4 THEN PRINT TAB(6);:X;:TAB(14);:
PRINT USING D$;RENT*((1+R)*(-X)-R)/R
NEXT X
IF FLAG=2 THEN CONSOLE:FLAG=D;GOTO 253
252 GOSUB 2200
IF FLAG=2 THEN 251
253 GOSUB 2300
PRINT CHR$(12);:ON PICK GOTO 250,200,10,5000
300 PRINT CHR$(12) REM ADD ON MENU
PRINT "BUYING ON INSTALLMENTS - ADD ON INTEREST, EQUAL PAYMENTS":PRINT
PRINT "1. FOR PURCHASE OF ITEM WHERE COST, ADD ON INTEREST AND NUMBER OF
PRINT "MONTHS ARE GIVEN. COMPUTES PAYMENTS AND ANNUAL PERCENTAGE RATE ."
PRINT "2. FOR PURCHASE OF ITEM WHERE COST, MONTHLY PAYMENT AND NUMBER
PRINT "OF MONTHS ARE GIVEN. COMPUTES ADD ON INTEREST RATE AND ANNUAL
PRINT "PERCENTAGE RATE.":PRINT:PRINT AS(9)
301 Y$=CONCHAR$ REM CHOICE OF 1 OR 2
IF Y$=(3) THEN 301
IF Y$=(4) OR Y$=(5) THEN PRINT CHR$(12);:
PRINT "PRESS NUMBER 1 OR 2 PLEASE":FOR X=1 TO 500:NEXT X:GOTO 301
CHOICE=Y$-48
350 PRINT CHR$(12);:PRINT:PRINT AS(1) REM ADD ON INPUT
PRINT AS(10);:INPUT "";:COST
IF CHOICE=1 THEN PRINT "ADD ON AT":AS(4);:INPUT "";:INTEREST
IF CHOICE=2 THEN PRINT "WHAT IS THE MONTHLY PAYMENT?":INPUT "";:MO;:PAYMENT
PRINT AS(11);:INPUT "";:MONTHS
IF COST<=0 OR CHOICE=1 AND INTEREST<=0 OR CHOICE=2 AND MONTHS<=0 THEN
PRINT:PRINT AS(15);:FOR X=1 TO 500:NEXT:PRINT CHR$(12);:GOTO 350
IF CHOICE=2 AND MO;:PAYMENT*MONTHS<=COST THEN PRINT
"*** PAYMENT NOT SUFFICIENT TO PAY LOAN AND INTEREST. PLEASE REENTER ***":
FOR X=1 TO 500:NEXT:PRINT CHR$(12);:GOTO 350
IF CHOICE=1 THEN MO;:PAYMENT=COST*(INTEREST/1200)+COST/MONTHS
IF CHOICE=2 THEN ADD_ON=(MO;:PAYMENT-COST/MONTHS)*1200/COST
PRINT CHR$(12) REM ADD ON PRINT
351 PRINT ES;:PRINT:PRINT "PURCHASE OF ITEM AT COST OF":PRINT USING D$;COST
IF CHOICE=1 THEN PRINT "AT":PRINT USING R$;INTEREST;:PRINT "ADD ON INTEREST"
IF CHOICE=2 THEN PRINT "WITH MONTHLY PAYMENT OF":PRINT USING D$;MO;:PAYMENT
PRINT "FOR":PRINT USING D$;MONTHS
IF CHOICE=1 THEN PRINT "MONTHLY PAYMENT WILL BE":PRINT USING D$;MO;:PAYMENT
IF CHOICE=2 THEN PRINT "ADD-ON INTEREST RATE IS":PRINT USING R$;ADD_ON
IF FLAG<2 THEN PRINT "*** COMPUTING ANNUAL PERCENTAGE RATE---PLEASE WAIT ***"
IF FLAG=2 THEN GOTO 354
L=MO;:PAYMENT/COST;:IO=MO;:PAYMENT/COST REM APR COMPUTATION
352 TEST=1+(1/(1+IO)^MONTHS)
APR=TEST*1200;:DIFF=IO-TEST;:IO=TEST
IF DIFF>0.00001 THEN 352
PRINT CHR$(30);:CHR$(0)
354 PRINT "ANNUAL PERCENTAGE RATE IS":PRINT USING R$;APR;:PRINT ES;:PRINT
IF FLAG=2 THEN CONSOLE:FLAG=D;GOTO 353
GOSUB 2200
IF FLAG=2 THEN 351
353 GOSUB 2300
PRINT CHR$(12);:ON PICK GOTO 350,300,10,5000
400 PRINT CHR$(12) REM INSTALL LOAN MENU
PRINT "BUYING ON INSTALLMENTS - PAYMENTS OF EQUAL PRINCIPAL PLUS INTEREST":PRINT
PRINT "COMPUTES MONTHLY PAYMENTS WHEN INTEREST IS CHARGED ON REDUCED BALANCE"
PRINT AS(12) AND COMPUTES EACH PAYMENT.
450 PRINT:PRINT AS(10);:INPUT "";:COST REM INSTALL LOAN INPUT
PRINT AS(4);:INPUT "";:INTEREST: PRINT AS(11);:INPUT "";:MONTHS
IF COST<=0 OR INTEREST<=0 OR MONTHS<=0 THEN PRINT:
PRINT AS(16);:FOR X=1 TO 500:NEXT:PRINT CHR$(12);:GOTO 450
PRINT CHR$(12) REM INSTALL LOAN COMPUTATION
451 PRINT X$:PRINT:PRINT "PURCHASE OF ITEM AT COST OF":PRINT USING D$;COST
PRINT "INTEREST RATE OF":PRINT USING R$;INTEREST
PRINT "TO BE PAID FOR OVER":PRINT USING D$;MONTHS;:PRINT "MONTHS"
R=INTEREST/1200;:MO;:PRIN=COST/MONTHS REM INSTALL LOAN PRINT
PRINT:PRINT TAB(10);"BALANCE BEFORE";:TAB(55);"TOTAL"
PRINT "MONTH";:TAB(13);"PAYMENT";:TAB(28);"INTEREST";:TAB(44);"PRINCIPAL";:
TAB(64);"PAYMENT";
FOR X=1 TO MONTHS
IF FLAG=0 AND X/17=INT(X/17) THEN PRINT:PRINT AS(14);:
INPUT "";:LINE Z$:PRINT
BALANCE=COST-(MO;:PRIN*(X-1));:MO;:INT=BALANCE;:TOTAL=MO;:PRIN+MO;:INT;:PRINT\
TAB(2);:X;:TAB(6);:PRINT USING D$;BALANCE;:TAB(22);:PRINT USING D$;MO;:INT;:
TAB(39);:PRINT USING D$;MO;:PRIN;:TAB(57);:PRINT USING D$;TOTAL;:NEXT X
PRINT:PRINT ES
IF FLAG=2 THEN CONSOLE:FLAG=D;GOTO 452
GOSUB 2200
IF FLAG=2 THEN 451
452 GOSUB 2300
PRINT CHR$(12);:ON PICK GOTO 450,400,10,5000
500 PRINT CHR$(12) REM LOAN AMORT MENU
PRINT "AMORTIZED LOANS - PAYMENT TABLES":PRINT
PRINT "1. LOAN TO BE PAID IN EQUAL PAYMENTS INCLUDING PRINCIPAL"
PRINT "AND INTEREST. DETERMINES AMOUNT OF PAYMENT.":PRINT AS(12)
PRINT "2. FOR PAYMENT OF GIVEN AMOUNT, DETERMINES PERIOD REQUIRED"
PRINT "TO PAY OFF LOAN. COMPUTES LAST PAYMENT IF DIFFERENT.":PRINT AS(12)
PRINT "3. BALANCE FOR PAY OFF OR BALLOON PAYMENT COMPUTED AFTER"
PRINT "CERTAIN NUMBER OF PAYMENTS ON LOAN WHERE PAYMENTS DETERMINED"
PRINT "AS IN 1.":AS(12)
PRINT "4. BALANCE FOR PAY OFF OR BALLOON PAYMENT COMPUTED AFTER"
PRINT "CERTAIN NUMBER OF PAYMENTS ON LOAN WHERE PAYMENTS DETERMINED"
PRINT "AS IN 2.":AS(12);:PRINT AS(9);:GOSUB 2000
550 PRINT CHR$(12);:PRINT:PRINT AS(1) REM LOAN AMORT INPUT
PRINT "WHAT IS AMOUNT OF LOAN? $:;INPUT "";:LOAN
IF CHOICE=2 OR CHOICE=4 THEN PRINT "WHAT IS AMOUNT OF PAYMENT? $:;
INPUT "";:PAYMENT
IF CHOICE=1 OR CHOICE=3 THEN PRINT "PAYMENTS SCHEDULE FOR":AS(5);:
INPUT "";:YEARS
PRINT AS(4);:INPUT "";:INTEREST;:PRINT AS(6);:INPUT "";:TIMES
IF CHOICE=3 OR CHOICE=4 THEN PRINT
"ENTER HOW MANY PAYMENTS DO YOU WANT BALANCE?":INPUT "";:NONRNR;:BAL;:FLAG=1

```

Program continues

When you purchase an apartment house, there is a second trust deed note for \$100,000 with monthly payments based on a 30 year schedule at 13 percent, all due in three years. How much will the balloon payment be? (Loan amortization menu option 3)

A loan of \$100,000.00 with payments 12 times a year at interest of 13.00% for 30 years requires payments of \$1,106.20 at end of 36 payments, balance is \$98,999.76

Period	Principal	Interest	Balance
1	\$22.87	\$1,083.33	\$99,977.13
2	\$23.11	\$1,083.09	\$99,954.02
3	\$23.36	\$1,082.84	\$99,930.66
4	\$23.62	\$1,082.58	\$99,907.04
5	\$23.87	\$1,082.33	\$99,883.16
6	\$24.13	\$1,082.07	\$99,859.03
7	\$24.39	\$1,081.81	\$99,834.64
8	\$24.66	\$1,081.54	\$99,809.98
9	\$24.92	\$1,081.27	\$99,785.06
10	\$25.19	\$1,081.00	\$99,759.86
11	\$25.47	\$1,080.73	\$99,734.39
12	\$25.74	\$1,080.46	\$99,708.65
13	\$26.02	\$1,080.18	\$99,682.63
14	\$26.30	\$1,079.90	\$99,656.32
15	\$26.59	\$1,079.61	\$99,629.74
16	\$26.86	\$1,079.32	\$99,602.86
17	\$27.17	\$1,079.03	\$99,575.69
18	\$27.46	\$1,078.74	\$99,548.23
19	\$27.76	\$1,078.44	\$99,520.47
20	\$28.06	\$1,078.14	\$99,492.40
21	\$28.37	\$1,077.83	\$99,464.04
22	\$28.67	\$1,077.53	\$99,435.37
23	\$28.98	\$1,077.22	\$99,406.38
24	\$29.30	\$1,076.90	\$99,377.09
25	\$29.61	\$1,076.59	\$99,347.47
26	\$29.94	\$1,076.26	\$99,317.54
27	\$30.26	\$1,075.94	\$99,287.28
28	\$30.59	\$1,075.61	\$99,256.69
29	\$30.92	\$1,075.28	\$99,225.77
30	\$31.25	\$1,074.95	\$99,194.52
31	\$31.59	\$1,074.61	\$99,162.93
32	\$31.93	\$1,074.27	\$99,130.99
33	\$32.28	\$1,073.92	\$99,098.71
34	\$32.63	\$1,073.57	\$99,066.06
35	\$32.98	\$1,073.22	\$99,033.10
36	\$33.34	\$1,072.86	\$98,999.76

Example 5

You can buy a trust deed note due in five years which had an original face amount of \$60,000, equal monthly payments over 10 years, and interest rate of 12 percent. How much should you pay for the note to earn 15 percent per year? (Yield menu option 1)

Purchase of note with \$60,000.00 face compounded 12 times a year at interest of 12.00% maturing in five years with original term 10 years for a yield of 15.00% must be purchased at a price of \$36,184.46 periodic payment will be \$660.83 remaining balance should be \$51,649.54

Example 6

If you pay 84 for a \$1000 bond paying 11.5 percent semi-annually, maturing in 12 years, what will be your annual rate of return (yield to maturity)? (Yield menu option 4)

Purchase of note with \$1,000.00 face compounded two times a year at interest of 11.50% maturing in 12 years for a price of \$840.00 will produce a yield of approximately 14.32%

Example 7

LNW80 COMPUTERS

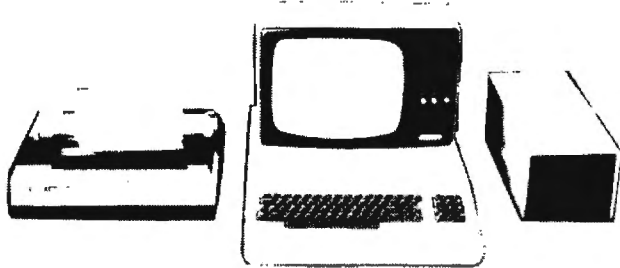

IN STOCK NOW!! CALL FOR SPECIAL
PRICES ON LNW80s, NEC PRINTERS,
RGB COLOR MONITORS, AND TANDON
DISK SYSTEMS,

***** NEW LNW SOFTWARE! *****

EXCELLONIX

7180 WOODROW WILSON DR
LOS ANGELES, CA 90068

(213) 650-5754 - (714) 973-1939

Program continued

```

IF CHOICE=2 AND PAYMENT<=0 OR CHOICE=4 AND PAYMENT<=0 OR (NAN=0 OR CHOICE=1
AND YEARS<=0 OR CHOICE=3 AND YEARS<=0 OR INTEREST<=0 OR TIMES<=0)
OR CHOICE=3 AND NUMBER<=0 OR CHOICE=4 AND NUMBER<=0)
  THEN PRINT:PRINT AS(1):FOR X=1 TO 50:NEXT:PRINT CHR$(12):GOTO 550
REM LOAN AMOUNT COMPUTATIONS
N=YEARS*TIMES:R=INTEREST*(100/TIMES):A=(1+R)^(N-1):D=(1+R)^(N-NUMBER)
IF (CHOICE=1 OR CHOICE=3 THEN PAYMNT=LOAN/R*(1-D)
  ELSE:PAYMNT/PAYMENT
IF (N>=1) AND CHOICE=2 OR C=1 AND (CHOICE=4 THEN PRINT:
  PRINT "PAYMENT NOT ENOUGH FOR INTEREST AND PRINCIPAL ***"
  PRINT PLEASE INPUT A DIFFERENT PAYMENT WHEN PROMPTED AND TRY AGAIN:
  FOR X=1 TO 50:NEXT:PRINT CHR$(12):GOTO 550
IF CHOICE=3 THEN BALLOAN=PAYMNT*(1-D)/R
IF (CHOICE=2 OR CHOICE=4 THEN R=LOG(1+(C/R)/LOG(1+R))
IF FLAG=1 AND INT(N)/7 THEN PRINT AS(14):INPUT "MONTH OR YEAR:"
  LAST.PAY=PAYMENT*(1-D)/R*(1+R)
IF CHOICE=4 AND N>INT(N) THEN F=(1+R)^(N-NUMBER):BALLOAN=PAYMENT*(1-F)/R
  PRINT CHR$(12) REM AMOUNT SUMMARY PRINTOUT
551 PRINT AS(1):PRINT "A LOAN OF "PRINT USING D5:LOAN:
  PRINT " WITH PAYMENTS "PRINT USING D5:PAYMNT:PRINT USING D5:INTFRST
  IF CHOICE=1 OR CHOICE=3 THEN PRINT "FOR "YEARS: YEARS:
  PRINT "REQUIRES PAYMENTS OF:"PRINT USING D5:PAYMNT:
  IF CHOICE=2 OR CHOICE=4 THEN PRINT "EACH PAYMENT "
  PRINT USING D5:TIMES:PRINT "REQUIRES PAYMENTS FOR "
  IF N>INT(N) AND CHOICE=2 THEN
    PRINT "LAST PAYMENT WILL BE "PRINT USING D5:LAST.PAY
  IF CHOICE=3 OR CHOICE=4 THEN PRINT
    "AT END OF "NUMBER:" PAYMENTS, BALANCE IS "PRINT USING D5:
    PRINT B5:PRINT
  IF FLAG=0 THEN GOSUB 2100
  IF FLAG=0 THEN 552
  PRINT:ACCPRI=-PAY*0 REM AMORTIZATION TABLE PRINTOUT
  PRINT PERIOD:TAB(15):"PRINCIPAL":TAB(32):"INTEREST":TAB(49):"BALANCE"
  IF BAL.FLAG=0 THEN FOR X=1 TO N
    IF BAL.FLAG=1 THEN FOR X=1 TO NUMBER
      PRI=-PAY*(PAYMENT-LOAN/R)*(1+R)^(X-1)
      ACCPRI=-PAY*ACCPRI-PAY*PRI-PAY*BAL*EXP(-ACCPRI*PRI*PAY
      PRINT TAB(2):X:TAB(10):PRINT USING D5:PRI:PRINT TAB(22):
      INT.PAY:PRINT USING D5:INT.PAY:PRINT USING D5:
      IF BAL.FLAG=1 THEN NEXT X
      IF BAL.FLAG=0 THEN NEXT X
  IF N>INT(N) AND CHOICE=2 THEN PRINT TAB(2):X:PRINT USING D5:
  LOAN-ACCPRI-PAY:PRINT USING D5:LOAN-ACCPRI-PAY:PRINT USING D5:
  USING D5:PRINT:PRINT:NOTE: LAST PAYMENT:IS REQUIRED PAY:FF AT END OF LOAN
  IF FLAG=2 THEN GOSUB:FLAG=0:GOTO 553
  552 GOSUB 2200
  IF FLAG=2 THEN 551
  553 GOSUB 2300
  PRINT CHR$(12):ON PICK GOTO 550,500,10,5000
600 PRINT CHR$(12) REM YIELD MENU
  PRINT "BUYING LOANS FOR A CERTAIN YIELD:PRINT
  PRINT ". DETERMINE PRICE TO BE PAID FOR NOTE WITH EQUAL PAYMENTS INCLUDING
  PRINT "INTEREST AT GIVEN INTEREST RATE TO OBTAIN DESIRED RATE OF RETURN.
  PRINT "2. DETERMINE PRICE TO BE PAID FOR NOTE WITH PERIODIC INTEREST
  PRINT "ONLY PAYMENTS AND PRINCIPAL PAID ON MATURITY TO OBTAIN DESIRED RATE OF
  PRINT "RETURN.
  PRINT "3. DETERMINE APPROXIMATE RETURN ON NOTE PURCHASED FOR CERTAIN AMOUNT
  PRINT "WHERE NOTE PAYABLE IN PAYMENTS INCLUDING INTEREST AT GIVEN RATE.
  PRINT "4. DETERMINE APPROXIMATE RETURN ON NOTE PURCHASED FOR A NOTE OR BOND
  PRINT " WITH PERIODIC INTEREST ONLY PAYMENTS, PRINCIPAL PAID ON MATURITY.
  PRINT:PRINT AS(9):GOSUB 2000
650 PRINT CHR$(127):PRINT AS(1) REM YIELD INPUT
  PRINT "WHAT WAS THE ORIGINAL FACE VALUE OF NOTE? "INPUT "FACE
  IF CHOICE=0 OR CHOICE=1
    PRINT "WHAT WAS ORIGINAL NUMBER OF YEARS OF NOTE? "INPUT "ORIGINAL
    PRINT AS(4):INPUT "INTEREST:PRINT:NOTE MATURES IN "AS(5):INPUT "YEARS
  IF CHOICE=1 AND YEARS<=0 OR CHOICE=3 AND YEARS<=0 OR CHOICE=4
  THEN PRINT "TIME LEFT EXCEEDED ORIGINAL TERM. REENTER***"
  FOR X=1 TO 50:NEXT:PRINT CHR$(12):GOTO 650
  PRINT "PAYMENTS MADE WHAT "AS(6):INPUT "TIMES
  IF CHOICE=1 OR CHOICE=2 THEN
    PRINT "WHAT IS ANNUAL INTEREST YOU RECEIVE ON NOTE? "INPUT "YIELD
  IF CHOICE=3 OR CHOICE=4 THEN
    PRINT "WHAT WILL YOU PAY FOR THE NOTE? "INPUT "PAID
  IF CHOICE=1 AND ORIGINAL<=0 OR CHOICE=2 AND ORIGINAL<=0 OR
  INTEREST<=0 OR YEARS<=0 OR TIMES<=0 OR CHOICE=3 AND YIELD<=0 OR
  CHOICE=4 AND YIELD<=0 OR CHOICE=3 AND PAID<=0 OR CHOICE=4 AND PAID<=0
  THEN PRINT AS(1):FOR X=1 TO 50:NEXT:PRINT CHR$(12):GOTO 650
  N=YEARS*TIMES:R=INTEREST*(100/TIMES):Y=PAID/TIMES:100:G=(1+Y)^(N-1)
  IF CHOICE=1 OR CHOICE=3 THEN Q=(1+R)^(N-1):ORIGINAL*TIMES:
  Z=FACE*(R/(1-Q))*R
  IF CHOICE=1 THEN PRICE=FACE*(R/(1-Q))*((1-G)/Y)
  IF CHOICE=2 OR CHOICE=4 THEN PAYMENT=FACE*
  IF CHOICE=2 THEN PRICE=FACE*PAYMENT*(1-G)/Y
  IF CHOICE=4 THEN COMP=(FACE-PAID)/(FACE*YEARS)
  IF CHOICE=3 THEN COMP=(Z-PAID)/(Z*YEARS*2)
  IF CHOICE=3 OR CHOICE=4 THEN ADD=INT(10000*COMP)/(10000*TIMES)
  GUESS1=R+ADD:R=(1+GUESS1)^(1-N)
  IF CHOICE=3 THEN PRICE1=Z/(PRICE1-GUESS1)
  IF CHOICE=4 THEN PRICE1=FACE*PAYMENT*(1-N)/GUESS1
  IF PRICE1>PAID THEN GUESS2=GUESS1+ADD
  IF PRICE1<PAID THEN GUESS2=GUESS1-ADD
  J=(1+GUESS2)^(1-N)
  IF CHOICE=3 THEN PRICE2=FACE*(R/(1-G))*((1-J)/GUESS2)
  IF CHOICE=4 THEN PRICE2=FACE*PAYMENT*(1-J)/GUESS2
  APPROX=((PRICE1-PAID)/(PRICE1-PRICE2)+(GUESS2-GUESS1)*TIMES)
  (GUESS2*TIMES)+100
  PRINT CHR$(12) REM YIELD PRINT
  PRINT AS(1):PRINT:PRINT "PURCHASE OF NOTE WITH "PRINT USING D5:FACE:
  PRINT "FACE":PRINT "COMPOUNDED "TIMES:AS(15):PRINT USING D5:INTEREST
  PRINT "MATURING IN "YEARS: YEARS"
  IF CHOICE=1 OR CHOICE=3 THEN PRINT "WITH ORIGINAL TERM "ORIGINAL: YEARS"
  IF CHOICE=1 OR CHOICE=2 THEN PRINT "FOR A YIELD OF "PRINT USING D5:YIELD:
  PRINT "MUST BE PURCHASED AT A PRICE OF "PRINT USING D5:PRICE
  IF CHOICE=1 OR CHOICE=3 THEN PRINT "PERIODIC PAYMENT WILL BE "
  PRINT USING D5:FACE*(R/(1-Q)):
  PRINT "REMAINING BALANCE SHOULD BE "PRINT USING D5:
  IF CHOICE=3 OR CHOICE=4 THEN PRINT "FOR A PRICE OF "PRINT USING D5:PAID:
  PRINT "WILL PRODUCE A YIELD OF APPROXIMATELY "PRINT USING D5:APPROX
  PRINT B5
  IF FLAG=2 THEN GOSUB:FLAG=0:GOTO 612
  GOSUB 2200
  IF FLAG=2 THEN 651
  612 GOSUB 2300
  PRINT CHR$(12):ON PICK GOTO 650,600,10,5000
2000 YZ=CUNCHARZ REM CHOOSE 1 TO 4 ROUTINE
  IF YZ<=32 THEN 2000
  IF YZ<=49 OR YZ<=52 THEN PRINT CHR$(127):
  PRINT "PRESS NUMBER FROM 1 TO 4 PLEASE"
  FOR X=1 TO 50:NEXT:GOTO 2000
  IF SUB.FLAG=2 THEN CHOICE=2:RETURN
  IF SUB.FLAG=1 THEN PICK=YZ-48:RETURN
  2100 PRINT AS(13):PRINT AS(8) REM SCREEN PRINT ROUTINE
  2110 YZ=CUNCHARZ
  IF YZ<=32 THEN 2110
  IF YZ<=53 OR YZ<=55 THEN PRINT CHR$(127):FLAG=3:RETURN
  PRINT CHR$(127):FLAG=0:RETURN
  2200 PRINT:PRINT AS(7):PRINT AS(8) REM PRINTR ROUTINE
  2210 YZ=CUNCHARZ
  IF YZ<=32 THEN 2210
  IF YZ<=50 OR YZ<=51 THEN PRINT CHR$(127):LPRINTR WIDTH 80:
  FLAG=2:RETURN
  PRINT CHR$(127):FLAG=0:RETURN
  2300 PRINT:PRINT:PRINT "PLEASE PRESS APPROPRIATE KEY" REM MENU CHOICE
  PRINT " WILL RETURN TO ROUTINE AGAIN." PRINT "2 WILL RETURN TO SUB MENU"
  PRINT "3 WILL RETURN TO MAIN MENU."PRINT "4 WILL END THE PROGRAM."
  SUB.FLAG=1:GOSUB 2000:SUB.FLAG=0:RETURN
  5000 PRINT CHR$(12):"END OF PROGRAM":STOP

```

for the TRS-80 from Micro-Mega

The Original GREEN-SCREEN



The eye-pleasing Green-Screen fits over the front of your TRS-80 Video Display and gives you improved contrast with reduced glare. You get bright luminous green characters and graphics like those featured by more expensive CRT units.

Don't confuse the Original Green-Screen with a piece of thin film stuck to the face of your video tube, such as that advertised by others. The Original Green-Screen is mounted in a full frame perfectly matched to the color and texture of the TRS-80 Video Display. It is attached with adhesive strips which do not mar your unit in any way.

The full frame design of the Original Green-Screen "squares off" the face of your video display and greatly improves the overall appearance of your system.

(Specify whether for Model I or Model III)

THE GREEN-SCREEN.....\$13.95
Add \$1.50 for postage and handling.

Terms: Check or money order, no CODs or credit cards, please. Add amount shown for postage and handling to price of the item. All items shipped within 48 hours by first class or priority mail. Virginia residents, add 4% sales tax.

162

Micro-Mega • P.O. Box 6265 • Arlington, Va 22206

CHECK OUR LOW PRICES ON

TRS-80* COMPUTERS & Accessories Software

NEW--NEW TRS-80* "Model-16"

16/32 Bit Computer. 128K RAM Std. 512K Max. 1 or 2 Built-in 1.25 MB Disk Drives. Multi-user capability. W/1 Drive \$4399.00 W/2 Drives \$5099.00. Call for low prices on other RS equip.

CORVUS* * HARD DISK DRIVES

Call for prices on 5-10-20 MB Hard Disks. We have the new CORDOS operating system which enables you to add a Hard Disk to TRS-80* Mod II with little or no modifications to your software. NEWDOS-80 and OASIS operating systems also available. Full service for CORVUS* and TRS-80's.

In business 27 years at the same location

Radio Ranch, Inc. -140

Cert. Check
Cashiers Ck.



Route 3, Radio Ranch Airport
Polo, Illinois 61064

Call Toll Free 800-435-8310

In Ill. Call 815-946-2371

*Trademark Lundy Corp.

Trademark Corvus systems, Inc.

MICRO MOONLIGHTER NEWSLETTER

The ONLY publication devoted exclusively to helping you create, build, and maintain a home-based business using your micro-system. SUBSCRIBE NOW to what may be the most important publication in YOUR FUTURE!

1 Year (12 issues) only \$25 U.S., \$29
Canada, \$35 World Wide

J. Norman Goode, Publisher

Micro Moonlighter Newsletter

2115-M Bernard Avenue • Nashville, TN 37212

Visa and Mastercard welcome. Send account number and expiration date.

Visa Acct # _____ Exp. _____

M/C Acct # _____ Exp. _____

Name _____

Address _____

City _____ St. _____ Zip _____

~270

PRACTICAL • ORIGINAL • SINGULAR • SUPERB • UNUSUAL

REFWARE THESAURUS INNOVATIVE INSTANT WORD-FINDER

WHAT'S THE BEST WORD???

How many times have you racked your brain for just the right word when writing an important letter, report, or article? How many times have your ideas been misunderstood because the words you used didn't express your thoughts clearly and accurately?

Now, by using the remarkable new REFWARE THESAURUS programs, your computer can speedily find those words that are on the tip of your tongue but that you can't quite remember at the moment. And it tells you how to spell them!

Just slip a REFWARE THESAURUS disk into your disk drive. Then type in your sentences or paragraphs. The computer will quickly offer a variety of alternatives, retyping your sentences or paragraphs with substitute possibilities chosen from its multi-thousand word vocabulary. It displays the revised sentences on your monitor or types them on your printer as you choose, so that you can mull them over and choose the one that most accurately expresses what you REALLY mean to say.

The revolutionary REFWARE THESAURUS programs bring the speed and power of the computer to the aid of anyone who wishes to improve his writing or speaking.

In addition to the specific programs capable of substituting suggested alternate words for nouns and adjectives, REFWARE THESAURUS Builder enables engineers, physicians, lawyers, educators, businessmen, authors, and other professionals and specialists to develop their own individually tailored vocabularies of hard-to-remember technical words.

REFWARE THESAURUS Adjectives 1.0

6,200 adjectives assist you in choosing the most accurate modifiers in your ads, letters, reports, and speeches

REFWARE THESAURUS Nouns 1.0

6,200 nouns suggest alternates for the names of persons, places, things, and ideas that you use in your writing and speaking.

REFWARE THESAURUS Builder 1.0

Series of eight utility programs enables the user to develop specialized computer thesaurus disk programs of hard-to-remember technical words and their alternates for personal use. Functions independently of Adjectives and Nouns programs.

REFWARE THESAURUS User's Manuals: Complete descriptions of use of each of the above programs. Included at no additional charge with each of program disks listed above. If ordered separately, price of manual is deductible from later order of program disk.

MINIMUM System Required TRS 80* Mod I or Mod III 48K with two disk drives.

*A Trademark of Tandy Corporation

Credit card orders phone (914) 238-8896

Dealer inquiries invited.

REFWARE* Reference software division David C. Whitney Associates, Inc.
P.O. Box 451, Chappaqua, N.Y. 10514

*A trademark of David C. Whitney Associates, Inc.

Specify Mod I () or Mod III ()

Qty.	Order No.	Title	Unit Price	Total
	1001RT	Adjectives 1.0	\$39.95	
	2001RT	Nouns 1.0	\$39.95	
	5001RT	Builder 1.0	\$149.95	
	6001RT	User's Manual Adj	\$9.95	
	6002RT	User's Manual Nouns	\$9.95	
	6003RT	User's Manual Builder	\$14.95	

Sales tax (N.Y. state residents only)

Postage and handling

\$ 3.00

Enclosed \$ _____ () Check () Money Order TOTAL \$

Bill: () Visa () MasterCard

Card # _____

Exp Date _____ Interbank # _____

Signature _____

Name _____ Phone () _____

Address _____

City _____ State _____ Zip _____

Mailed First Class, but allow 3 to 4 weeks for delivery, no C.O.D. orders

CLEVER • SUPERLATIVE • FIRST-RATE • WORTHY • SPECIAL • IDEAL • INVALUABLE • SUPER • PRAISEWORTHY • SUPERIOR • SKILLFUL • NOTABLE • NIFTY • EXPRESSIVE • FANTASTIC • REMARKABLE • USEFUL • MEANINGFUL • IMPORTANT • SIGNIFICANT • MARVELOUS • WONDERFUL • OUTSTANDING • EXCELLENT • INCLUSIVE • MATCHLESS •



Make multiple choice, true-false, short answer or completion tests for your students.

Time to Make 'em Sweat

Robert L. Hawkes
Berwick Academy
South Berwick, ME 03908

questions.

File Names

The file names have a standard format and an extension holds the key to the test format. The last letter of the extension keys this. The MC extension gives one test format while the SA, TF, and COM extensions use another format. An example of a file name would be PSYCH16/MC.

Three Program Options

The write option stores test items on the file in two available formats. The first, for multiple choice items, stores the text of the question, the letter of the correct answer and an appropriate chapter number. The text may be 253 characters. Although Basic accepts only up to 240 characters you may edit in additional characters later. An example of a multiple choice

Richard Eckert's article "Quizmaster" (*80 Microcomputing*, June 1980) prompted me to write a program I needed to file storage for multiple choice questions for a course I was teaching. I expanded the idea of random access disk files to other types of test item storage, various print formats and item editing. The program stores multiple choice (MC), completion (COM), true-false (TF) and short answer (SA)

The Key Box

Basic Level II
Model I
32K RAM
TRSDOS
Line Printer I

```
ITEM #3
TEXT? JAMES B. WATSON IS OFTEN CALLED THE FATHER OF ****
A) PSYCHOLOGY
B) BEHAVIORISM
C) HUMANISM
D) GESTALT PSYCHOLOGY

LETTER OF CORRECT ANSWER? B
CHAPTER NUMBER? 1
```

Fig. 1. Multiple choice example

```
ITEM #30
TEXT? JAMES B. WATSON IS OFTEN CALLED THE FATHER OF ****

CORRECT ANSWER? BEHAVIORISM
```

Fig. 2. Completion example

```
ITEM #18
TEXT? THE AREA OF A CIRCLE WITH A RADIUS OF 8 IS ****

CORRECT ANSWER? 64 PI
```

Fig. 3. Short answer example

```
ITEM #9
TEXT? THE SIDE OF A RIGHT TRIANGLE WHICH IS OPPOSITE THE RIGHT
ANGLE IS CALLED THE HYPOTHESIS.

CORRECT ANSWER? FALSE
```

Fig. 4. True/False example

question is in Fig. 1. Remember to use the down arrow to go from one line to the next. Use the Enter key only when you have completed the text.

The other format stores 200 text characters and a 20 character correct answer. Figures 2, 3 and 4 show these item types.

Three read options print the test items.

- Dump prints test items including answers on the video screen in blocks of two multiple choice items or five general items.

- LDUMP prints test items including answers on the line printer at a rate of seven items per page for multiple choice and 25 items per page for other item types.

- LPRINT prints test items without answers on the line printer in an appropriate testing format. Printings are available with an answer blank for each item or with instructions to use a separate answer sheet. All read options delay printing each item. The program reads each item into a buffer before printing it. This supplies the printer with the needed characters and no string of blanks for unused fielded characters. Use the Edit option to change individual test items. After the selected item has been displayed you may choose to fix or replace part or all of the item.

The following Edit functions are available when you select the fix option: The space bar moves to the next character; C changes the next character; D deletes the next character; I allows an insert of one or more characters. To escape the insert, press the @ key. Pressing @ proceeds to the end of the item and restores it to the file with no further corrections. X extends the item.

When you select the replace option, the program discards the old item and requests an entirely new item to replace it. These Edit functions are like those in Level II Basic but not as comprehensive. ■

Robert Hawkes, previously an instructor in math and psychology, currently teaches computer programming.

Program Listing

```

100 REM                                TEST ITEM FILE PROGRAM
110 REM                                R. HAWKES
120 REM                                BERWICK ACADEMY, SO. BERWICK, MAINE
130 REM                                1981
140 CLEAR 1000:DIM A(100):CLS
150 INPUT"NAME OF FILE";F$
160 TF$=RIGHT$(F$,1)
170 INPUT"DO YOU WISH TO (READ) OR (WRITE) OR (EDIT)";ZZ$
180 IF ZZ$="EDIT" THEN 1720
190 IF ZZ$="READ" THEN 560
200 IF ZZ$="WRITE" THEN 220
210 PRINT"REDO":GOTO 170
220 GOSUB 1540 :N=LOF(1):CLOSE
230 PRINT"LAST RECORD NUMBER IS";N
240 GOSUB 1570
250 N=N+1
260 CLS:PRINT"ITEM #:";N
270 IF TF$="C" THEN 340
280 IF TF$="M" THEN 460
290 IF TF$="A" THEN 460
300 IF TF$="F" THEN 460
310 PRINT:PRINT"ANOTHER ITEM? Y OR N? ":GOSUB 2070
320 IF YN$="Y" THEN 250
330 GOSUB 2680
340 REM                                WRITE MC TEST
350 LINE INPUT"TEXT? ";B$
360 INPUT"LETTER OF CORRECT ANSWER";C$
370 INPUT"CHAPTER NUMBER";D
380 PRINT:PRINT"IS ITEM OK FOR STORAGE? Y OR N? ":GOSUB 2070
390 IF YN$="N" THEN 260
400 GOSUB 1540 :GOSUB 1550
410 LSET T$=B$
420 LSET L$=C$:LSET CN$=MKI$(D)
430 PUT 1,N
440 CLOSE
450 GOTO 310
460 REM                                WRITE OTHER TESTS
470 LINE INPUT"TEXT? ";B$
480 INPUT"CORRECT ANSWER";A$
490 PRINT:PRINT"IS ITEM OK FOR STORAGE? Y OR N? ":GOSUB 2070
500 IF YN$="N" THEN 260
510 GOSUB 1540 :GOSUB 1560
520 LSET T$=B$:LSET AN$=A$
530 PUT 1,N
540 CLOSE
550 GOTO 310
560 REM                                READ FILES
570 CLS:PRINT"INDICATE THE TYPE OF READ WANTED"
580 INPUT"(DUMP) OR (LDUMP) OR (LPRINT)";TR$
590 IF TR$="DUMP" THEN 630
600 IF TR$="LDUMP" THEN 850
610 IF TR$="LPRINT" THEN 1070
620 PRINT"REDO":GOTO 580
630 CLS:PRINT F$
640 GOSUB 1540 :N=LOF(1):CLOSE
650 IF TF$="C" THEN 750
660 FOR I=1 TO N
670 PRINT I;" ";
680 GOSUB 1540 :GOSUB 1560 :GET 1,I:CLOSE
690 GOSUB 1580
700 PRINT "ANS: ";AN$
710 IF I/5=INT(I/5) THEN INPUT"PRESS ENTER";Z$:CLS
720 NEXT I
730 PRINT:INPUT"END OF FILE - PRESS ENTER";Z$
740 GOSUB 2680
750 FOR I=1 TO N
760 PRINT I;" ";
770 GOSUB 1540 :GOSUB 1550 :GET 1,I:CLOSE
780 D=CVI(CN$)
790 GOSUB 1580
800 PRINT "ANSWER - ";L$,"CHAPTER #";D
810 IF I/2=INT(I/2) THEN INPUT"PRESS ENTER";Z$:CLS
820 NEXT I
830 PRINT:INPUT"END OF FILE - PRESS ENTER";Z$
840 GOSUB 2680
850 REM                                LDUMP
860 GOSUB 1640
870 LPRINT F$
880 GOSUB 1540 :N=LOF(1):CLOSE
890 IF TF$="C" THEN 980
900 FOR I=1 TO N
910 LPRINT I;" ";
920 GOSUB 1540 :GOSUB 1560 :GET 1,I:CLOSE
930 GOSUB 1610
940 LPRINT TAB(55)"ANSWER: ";AN$
950 IF I/30=INT(I/30) THEN LPRINT CHR$(12):LPRINT F$:LPRINT "
960 NEXT I

```

Program continues

COMPUTER GAMES
 TRS-80 MODEL 1/3 16K LEVEL II
 TRS-80 16K COLOR AND 8K PET

DEMONSTRATION PROGRAM "FROG RACE" COMES ON CASSETTE WITH A FULL REFUND COUPON TO USE ON YOUR NEXT ORDER.
 FROG RACE CASSETTE \$3. WITH CATALOG

DUO-PAK'S ARE \$10 DOLLARS EACH.

NO.	PGM SIDE 1	PGM SIDE 2
1	GONE FISHING	CONCENTRATION
2	CRAPS	SLOT-MACHINE
3	STARSHIP	SHERLOCK HOLMES
4	TANK ATTACK	ASSOCIATION
5	NUMBER GUESS	DICE ROLL
6	IN-BETWEEN	SHELL GAME
7	SAFARI	STARSHIP-2
8	MORTAR BATTLE	PUZZLE
9	TEASER	MOUSE
10	PT BOAT	TURTLE RACE
11	CHEK-CHEK	STARSHIP-3
12	THINK	LUCK & LOGIC
13	TREASURE ISLAND	RESCUE

SHIPPED 1ST CLASS MAIL PPD. - NO COD'S.
 SPECIFY WHAT COMPUTER YOU HAVE.
 B. ERICKSON P.O. BOX 11099
 CHICAGO, IL 60611 ✓371

TRS-80

COMPUTER DISCOUNTS

- Factory Direct
- Best Prices Anywhere
- No Out-of-State Taxes
- Full Radio Shack Warranty
- Free Price List

SCOTT TASSO

Owner
 Radio Shack Associate Store #7053
 175 E North Delsea Drive
 Vineland, N.J. 08360
 600-257-0426
 NJ 809-691-7100 ✓510

"COMPUTER ACCESSORIES OF ARIZONA PRESENTS"
 PRODUCTS FOR THE
 "TRS-80" COLOR COMPUTER"

1248-EP EPROM PROGRAMMER \$94.95

- | | | |
|---|--|--|
| <ul style="list-style-type: none"> • Software driver in EPROM • Totally menu driven • 16K EPROM erasure • Program memory blocks 16K • Weekly programs • Includes onboard 25-kill programming supply | <p>PROGRAMS</p> <ul style="list-style-type: none"> • 250K • 215K 1 • 751K • 271K • 252 • 68732-0 1 • 68734 | <ul style="list-style-type: none"> • Quality 1/4" x 1/2" sheet • Address deriving opt on • 120V/110V/60Hz opt use of ROM 250K memory module • MCA's professional software • Development system when used with Micro Works 5250001 writer system |
|---|--|--|

CK4 PROM/ROM CARD \$29.95

MEDK80 MORSE EN-DECODER KIT \$39.95

- | | |
|--|--|
| <ul style="list-style-type: none"> • ROM pack space decoded into 24 bins • Switches to write protect RAM's • Use 4 2716's or 4016's • Use 4 or ROM's or 2 8K ROM's | <ul style="list-style-type: none"> • Use any 8MHz or RCVR • Speed 10/10Hz • RCVR aut. speed adapts • Includes schematic PCB components, instructions and software update |
|--|--|

"COMPARE PRICE!" "COMPARE VALUE!"
 YOU'LL BUY FROM:
 COMPUTER ACCESSORIES OF ARIZONA
 5801 E. VOLTAIRE DR.
 SCOTTSDALE, AZ 85254

MAKE CHECKS OR MONEY ORDERS PAYABLE TO THE ABOVE ADDRESS
 ARIZONA RESIDENTS ADD 5% SALES TAX
 TRS-80 IS A TRADEMARK OF TANDY CORP.
 5250001 IS A TRADEMARK OF THE MICRO WORKS

✓382

Program continued

```

970 GOSUB 2680
980 FOR I=1 TO N
990 LPRINT I;" ";
1000 GOSUB 1540 :GOSUB 1550 :GET 1,I:CLOSE
1010 D=CVI(CN$)
1020 GOSUB 1610
1030 LPRINT"ANSWER - ";L$, "CHAPTER # - ";D:LPRINT" "
1040 IF I/8=INT(I/8) THEN LPRINT CHR$(12):LPRINT F$
1050 NEXT I
1060 GOTO 2680
1070 REM
1080 CLS:INPUT"HOW MANY TEST ITEMS NEEDED";NN
1090 FOR I=1 TO NN
1100 PRINT"INPUT RECORD #";I;
1110 INPUT A(I)
1120 NEXT I
1130 GOSUB 1640
1140 CLS:PRINT"IS THIS PART OF A LARGER TEST? Y OR N? ":GOSUB 20
70
1150 IF YN$="Y" INPUT"WHAT IS THE PART NUMBER";D8
1160 INPUT"IS THERE A SEPARATE ANSWER SHEET? YES OR NO";AS$
1170 IF YN$="Y" THEN LPRINT "PART";D8;" ";
1180 IF TF$="C" THEN 1200
1190 GOTO 1370
1200 REM
1210 IF AS$<>"YES" THEN 1250
1220 LPRINT "ON THE ANSWER SHEET CIRCLE THE LETTER OF THE"
1230 LPRINT TAB(8)"CORRECT ANSWER FOR EACH."
1240 GOTO 1270
1250 LPRINT"INSERT IN THE PARENTHESIS THE LETTER OF THE"
1260 LPRINT TAB(8)"CORRECT ANSWER FOR EACH."
1270 LPRINT" "
1280 FOR I=1 TO NN
1290 LPRINT I;" ";
1300 GOSUB 1540 :GOSUB 1550 :GET 1,A(I):CLOSE
1310 GOSUB 1610
1320 IF AS$<>"YES" LPRINT TAB(50) I;" ( )"
1330 IF I/8=INT(I/8) LPRINT CHR$(12):GOTO 1350
1340 LPRINT" "
1350 NEXT I
1360 GOSUB 2680
1370 REM
1380 IF AS$<>"YES" THEN 1420
1390 LPRINT"ON THE ANSWER SHEET PLACE THE PROPER ANSWER FOR EACH"
"
1400 LPRINT TAB(8)"QUESTION IN THE PROPER BLANK."
1410 GOTO 1440
1420 LPRINT"PLACE IN THE PARENTHESIS THE PROPER ANSWER FOR"
1430 LPRINT TAB(8)"EACH QUESTION."
1440 LPRINT" "
1450 FOR I=1 TO NN
1460 LPRINT I;" ";
1470 GOSUB 1540 :GOSUB 1560 :GET 1,A(I):CLOSE
1480 GOSUB 1610
1490 IF AS$<>"YES" LPRINT TAB(60) I;" ( )":GOTO 1510
1500 LPRINT" "
1510 PK=PEEK(16425):IF PK>60 LPRINT CHR$(12)
1520 NEXT I
1530 GOTO 2680
1540 OPEN"R",1,F$:RETURN
1550 FIELD 1,2 AS CN$,1 AS L$,253 AS T$:RETURN
1560 FIELD 1,200 AS T$,20 AS AN$:RETURN
1570 FOR WT=1 TO 1200:NEXT WT:RETURN
1580 LS=INSTR(T$, " ")
1590 IF LS<>0 M$=LEFT$(T$,LS)
1600 PRINT M$:RETURN
1610 LS=INSTR(T$, " ")
1620 IF LS<>0 M$=LEFT$(T$,LS) ELSE M$=T$
1630 LPRINT M$:RETURN
1640 REM
1650 CLS:PRINT"IS LINE PRINTER ON? Y OR N? ":GOSUB 2070
1660 IF YN$="Y" THEN 1680
1670 PRINT"PLEASE TURN IT ON":GOTO 1650
1680 POKE 16425,1
1690 CLS:PRINT"POSITION PAPER PROPERLY"
1700 INPUT"PRESS <ENTER> WHEN READY";ZM$
1710 RETURN
1720 REM
1730 INPUT"ITEM NUMBER";V:M$=""
1740 IF TF$="C" THEN 1760
1750 GOSUB 1540 :GOSUB 1560 :GET 1,V:CLOSE:GOTO 2170
1760 GOSUB 1540 :GOSUB 1550 :GET 1,V
1770 D=CVI(CN$):CLOSE
1780 PRINT T$
1790 PRINT"ANS-";L$, "CHAPT # -";D
1800 PRINT "IS ITEM OK? Y OR N? ":GOSUB 2070
1810 IF YN$="Y" THEN 2490
1820 PRINT"INDICATE THE TYPE OF EDIT WANTED"
1830 INPUT"(ITEM) OR (TEXT) OR (OTHER)";ES$
  
```

Program continues

Program continued

```
1840 IF ES$="TEXT" THEN 1960
1850 IF ES$="ITEM" PRINT"DO OTHERS FIRST":PRINT
1860 PRINT"INDICATE (OK) OR MAKE THE CORRECTION"
1870 PRINT"ANS -";L$;:INPUT" OK";OK$
1880 IF OK$<>"OK" LSET L$=OK$
1890 PRINT"CHAPT # -";D;:INPUT" OK";OK$
1900 IF OK$<>"OK" THEN D=VAL(OK$):LSET CN$=MKI$(D)
1910 GOSUB 1540
1920 IF TF$="C" GOSUB 1550 ELSE GOSUB 1560
1930 PUT 1,V:CLOSE
1940 IF ES$<>"ITEM" THEN 2490
1950 REM " EDIT TEXT (MC)
1960 PRINT"TEXT CORRECTION:":INPUT"(FIX) OR (REPLACE)";FR$
1970 IF FR$="FIX" THEN 2120
1980 LINE INPUT"TEXT? ";B$
1990 PRINT:PRINT"OK FOR STORAGE? Y OR N? ":GOSUB 2070
2000 IF YN$="Y" THEN 2040
2010 INPUT"ANOTHER TRY? Y OR N? ":GOSUB 2070
2020 IF YN$="Y" THEN 1980
2030 GOTO 2490
2040 GOSUB 1540 :GOSUB 1550
2050 LSET T$=B$:PUT 1,V:CLOSE
2060 GOTO 2490
2070 REM INKEY$ ROUTINE FOR YES OR NO
2080 YN$=INKEY$:IF YN$="" THEN 2080
2090 IF YN$<>"Y" AND YN$<>"N" THEN 2080
2100 RETURN
2110 REM FIX MC
2120 LS=INSTR(T$," "):GOSUB 2320
2130 GOSUB 1540 :GOSUB 1550
2140 LSET T$=M$:PUT 1,V
2150 CLOSE
2160 GOTO 2490
2170 REM EDIT OTHER TESTS
2180 PRINT T$
2190 PRINT AN$
2200 INPUT"IS ANSWER OK";YN$
2210 IF YN$="YES" THEN 2240
2220 INPUT"NEW ANSWER";A$
2230 GOSUB 1540 :GOSUB 1560 :LSET AN$=A$:PUT 1,V:CLOSE
2240 PRINT"IS TEXT OK? Y OR N? ":GOSUB 2070
2250 IF YN$="Y" THEN 2300
2260 LS=INSTR(T$," "):GOSUB 2320
2270 GOSUB 1540 :GOSUB 1560
2280 LSET T$=M$:PUT 1,V
2290 CLOSE
2300 GOTO 2490
2310 LS=INSTR(T$," ")
2320 FOR II=1 TO LS
2330 A$=MID$(T$,II,1)
2340 IF I$="@ " OR I$="X" THEN 2440
2350 IF II=1 PRINT "***";
2360 I$=INKEY$
2370 IF I$="" THEN 2360
2380 IF I$=" " THEN 2440
2390 IF I$="C" GOSUB 2530 :GOTO 2440
2400 IF I$="@ " THEN 2440
2410 IF I$="I" GOSUB 2600 :GOTO 2440
2420 IF I$="D" GOSUB 2570 :GOTO 2470
2430 IF I$=";" THEN 2480
2440 M$=M$+A$
2450 PRINT A$;
2460 IF I$="X" AND II=LS-1 THEN GOSUB 2600
2470 NEXT II
2480 RETURN
2490 CLOSE:PRINT:PRINT "DO YOU WANT ANOTHER EDIT? Y OR N? ":GOS
UB 2070 :M$="":I$=""
2500 IF YN$="N" THEN 2690
2510 M$="":I$="":CLS:GOTO 1720
2520 END
2530 REM CHANGE THE LETTER
2540 A$=INKEY$
2550 IF A$="" THEN 2540
2560 RETURN
2570 REM DELETE A CHARACTER
2580 A$=""
2590 RETURN
2600 REM INSERT ROUTINE
2610 Q$=INKEY$
2620 IF Q$="" THEN 2610
2630 IF Q$="@ " THEN 2670
2640 PRINT Q$;
2650 M$=M$+Q$
2660 GOTO 2610
2670 RETURN
2680 REM MORE?
2690 CLS:PRINT"DO YOU WISH FURTHER WORK ON THIS FILE? Y OR N? "
:GOSUB 2070
2700 IF YN$="Y" THEN 160
2710 END
```

— NEW — WORD PROCESSING STATIONERY

CLEAN-EDGE CONTINUOUS
TRACTOR FEED LETTERHEAD
NO PIN HOLE EDGES
CUT SHEET APPEARANCE
REASONABLE COST
BLACK OR COLOR PRINTING
VARIETY OF PAPERS
OFF THE SHELF DELIVERY
PRICE & SAMPLES

RABCO ENTERPRISES
806 FREEDOM CIRCLE
HARLEYSVILLE, PA 19438

✓366

COLORTERM

The Color Computer* as an intelligent terminal
with 51 or 64 columns by 21 lines
plus true lowercase! All done in software.

Any data format -16K or 32K -300 or 110 Baud

Print and save host data to cassette

Encode data for secure storage

User programmable keys

Much more! ✓332

"...very impressed..." - The Rainbow

\$34.95 (U.S.) 40.95 (Canadian)
M.O. VISA, M/C (include expiry)

MARTIN CONSULTING, 94 Macalester Bay
Winnipeg, Man. R3T 2X5 CANADA

*T.M. of Tandy Corp.

for POCKET COMPUTERS

Game Pac 1: OLD FAVORITES

Five proven games, updated with exciting new features. Fun for all! PLANET-Land on any planet. ZILCH-Bagles, 1-9 digit numbers. HILO-Nifty version of Stars. COINS-Computer "learns" to win. WINNER-You Lose! Includes complete notes and listings \$9.
with cassette \$14.

BEGINNERS GUIDE TO PROGRAMMING

the Sharp/Radio Shack Pocket Computer
It's fast, fun and easy. You'll understand every word and be amazed how easily you progress. No other method brings positive results so quickly \$19.

YOU AND YOUR DOLLARS: ALL ABOUT INTEREST

99 basic questions answered with 17 dynamite programs. Includes variable and fixed rate home loans. Also annuities, present and future value, notes and contracts, cash flow analysis and much more. \$19.
with cassette \$33.

(Remit in U.S. funds. Add \$2 for first class delivery. Add \$3 if outside U.S. Calif. add 6% sales tax.)

AND WE HAVE OTHERS! For a copy of our catalog, circle our number on your bingo card or write directly.

HANCO Software (formerly XCEL)
P.O. Box 4772H, Sylmar, CA 91342
(213) 367-4366

✓370

Color these NJ second graders TRS-80

by Kerry Leichtman

80 Micro staff

As the Color Computer finds a home in schools across the country, more and more applications are being aimed at secondary and college students — a situation that concerned elementary teacher Marilyn Scarnaty of Bloomfield, NJ. So she decided to do something about it by writing computer programs for her classes.

"Many of the teaching packages sold glance over the younger students in favor of older kids," she said. "There should be more elementary school programs."

Scarnaty teaches second grade students designated as slow learners at the Kentopp School in East Orange, NJ. She has had success with her students using programs she wrote for the Color

Computer.

Two years ago representatives from Radio Shack visited the East Orange school district and demonstrated the Model I's teaching abilities. The district was impressed enough to send a few teachers to Radio Shack to learn more about educational computer uses, and to buy six Model I's. But, Scarnaty said, it

didn't go much further. Sometime later, the school bought a 16K Color Computer. Scarnaty took the computer home and experimented with it. Soon after, she bought a 4K machine for herself.

"Vowels are hard for children to comprehend," she told *80 Micro* in a telephone interview. "So once I got the hang of it, I started to write programs to help me teach them to the children." Elementary math concepts are also difficult to grasp, so she wrote programs on this subject too.

The kids love it, she said. Questions are put to them in multiple choice form. A right answer displays a happy face before asking the next question. The concept is constant reinforcement. "If a wrong answer is given, the program goes back to



photo by Don Cohen of East Orange Record

Marilyn Scarnaty guides a student through a lesson on the Model I.

Expensive Expansion



EXPENSIVE - The *LNW System Expansion II* and built-in comes with a full 32K of 200ns RAM, RS232c 20 MA current loop serial interface. That's for starters. Next, consider our heavy gauge steel case, power indicator lamp, gold-plated connectors, FR-2 glass epoxy circuit board with solder mask and silk screen legends. Then there is the parallel printer port, screen printer port, real time clock, and extra heavy duty onboard power supply with over current protection, over voltage protection and thermal shutdown. If that's not enough then there is the floppy disk controller, guaranteed operation at a 4MHz CPU speed and our 6 month warranty. Every one of these features is *STANDARD*. This is true system expansion. You get every 'expensive' feature without spending more.

CHEAP - Our price is \$399.95. Any way you compare, features or price, *LNW's System Expansion II* is the clear winner. The *LNW System* has been field tested for over two years with thousands of users. It works with any DOS, is 100% TRS-80 Model I compatible and it works 'right out of the box'. If there is any doubt in your mind as to whether you should buy ours or the 'other guys', just ask an *LNW* owner!

WE ARE #1 - Number one in price, features, reliability, performance and delivery. *LNW* is committed to 'expensive' features and quality at reasonable prices. *LNW* is committed to support, thorough documentation, and reliability.

LNW Research Corp.

2620 WALNUT Tustin, CA. 92680
(714) 641-8850 (714) 544-5744

This has made us the number one manufacturer of system expansion units and accessories for the Model I computer.

EXPANSION OPTION - 8-inch drive capability is as easy as plugging in the *LNDoubler 5/8* option*. Now you can have any combination of single- or double-density, single- or double-sided, 8" and/or 5" disks on-line! 8-inch disk storage increased to 591,360 bytes - 77-track single-sided, double-density or 1,182,720 bytes - 77-track double-density, double-sided.

The *LNDoubler's* unique 5/8 switch allows you to boot from 5- or 8-inch system disks and it's accessible from outside the interface. The \$219.95 *LNDoubler 5/8* comes with a double-density disk operating system (DOS+ 3.3.9), complete with BASIC and utility programs... ready to run your software.

Each of your present 40-track, single-sided 5-inch drives will store up to 184,320 bytes (formatted storage) - that's an 80% increase in storage capacity for only half the cost of just one disk drive. With three 8-inch double-density, double-sided drives your Model I will have 3.75 Megabytes of online storage - that's more storage than a Model II or Model III!



TEACHER_{continued}

the first question, so the student can work his way up to the one he got wrong," Scarnaty explained. After successfully completing a drill, the student is treated to a tune played for him by the computer. (See program listings.)

Although Scarnaty has just recently introduced the Color Computer to her second grade students, she has already documented its success with hard to dispute facts. Two weeks prior to a week long vacation she had her students work with her verb agreement program: the difference between usages of is and are, was and were; and her affixes program: proper use of the suffixes ed, s and ing.

The first thing she did with her students the Monday morning after vacation was test their comprehension on these skills. No review was given. The 20-question test was on paper and they had to write their answers in with pencil. "I was looking for

70 percent mastery," Scarnaty said, "and the entire class achieved 72 percent or better." In fact, only two students scored as low as 72 percent. Four students got all the questions right, three scored 96 percent, two 92 percent, one 88, two 84, three 80 and the remaining four 76 percent.

Did the students just happen to get lucky? To find out, Scarnaty gave them a second test. "Just for comparison," she told *80 Micro*, "I checked their addition and subtraction with regrouping, which was not computerized. We had been working on this for almost two months. They forgot what to do."

Not only are the children learning through the computer, but its presence is improving their classroom behavior. "They know if they misbehave, they're not going to be allowed to get a turn at the computer," Scarnaty said.

Scarnaty has become a believer in the computer's place in the classroom. She has given workshops and demonstrations

for other teachers and is hoping they and school administrators will take notice of its capabilities. "They put money out for things that don't work," she said. "The computer works. You don't finish with it and throw it away, you use it again and again. It will last for quite a while."

Scarnaty thinks it's unfortunate that some teachers see micros in the classroom as threats. "I use it as a supplement," she said. "Instead of getting one lesson across in a certain amount of time, I can get two across." Not only that, but teachers are being held more accountable for their students' progress. In Scarnaty's opinion, a computer in the classroom, rather than a threat, is more like job security. "With the big stress on teacher accountability, teachers are looking for any type of tool to aid them in the classroom. I have found the micro-computer to be such a tool. It's like old-fashioned teaching, you're just drilling them. ■

PROGRAM LISTING

TITLE:VOWELS PROGRAM WRITTEN BY MARILYN SCARNATY
SAMPLE OF A 5-PART LESSON WRITTEN FOR A 4K COLOR COMPUTER.
SONG TUNE IS "WHEN YOU WISH UPON A STAR"

```

5 PRINT"READ THE SENTENCES AND PICK THE CORRECT WORD"
10 PRINT" "
15 PRINT"1.HE WORE A...ON HIS HEAD."
20 PRINT" "
25 PRINT"1.BEAD 2.BAT 3.HAT"
30 PRINT" "
35 PRINT"PRESS YOUR ANSWER 1,2 OR 3"
40 PRINT" "
45 INPUT"PICK THE WORD WITH THE SHORT A SOUND AND PRESS
ENTER";A
50 PRINT" "
55 IF A=1 THEN PRINT"TRY AGAIN":GOTO 15
56 PRINT" "
57 IF A=2 THEN PRINT"TRY AGAIN":GOTO15
58 PRINT" "
60 IF A=3 THEN GOTO 65
65 CLS(5)
70 FOR H=15TO48
75 SET(H,5,5)
80 SET(H,20,5)
85 NEXT H
90 FOR V=5TO20
95 SET(15,V,5)
100 SET(48,V,5)
105 NEXT V
110 SET(32,13,8)
115 FOR H=28TO36
120 SET(H,16,4)
125 NEXT H
130 SET(25,10,3)
135 SET(38,10,3)
140 INPUT"PRESS ENTER TO CONTINUE";AS
145 PRINT"2.THE BABY IS VERY...."
150 PRINT" "
165 PRINT"1.CUT 2.CUTE 3.NICE"
170 PRINT" "
175 PRINT"PRESS YOUR ANSWER 1 2 OR 3"
180 PRINT" "
185 INPUT"PICK THE WORD WITH THE LONG U SOUND AND PRESS
ENTER";A
190 IF A=1 THEN PRINT"TRY AGAIN":GOTO 145
191 PRINT" "
192 IF A=3 THEN PRINT"TRY AGAIN":GOTO 145
193 PRINT" "
195 IF A=2 THEN GOTO 200
200 CLS(4)
205 FOR H=15TO48
210 SET(H,5,5)
215 SET(H,20,5)
220 NEXT H
225 FOR V=5TO20
230 SET(15,V,5)
235 SET(48,V,5)
240 NEXT V
245 SET(32,13,8)
250 FOR H=28TO36
255 SET(H,16,4)
260 NEXT H
265 SET(25,10,3)
270 SET(38,10,3)
275 INPUT"PRESS ENTER TO CONTINUE";AS
280 PRINT"HOW MANY DID YOU GET RIGHT?"
285 PRINT" "
290 PRINT"1.HAT 2.CUTE"
295 PRINT" "
300 INPUT"PRESS YOUR NUMBER RIGHT 1 OR 2 AND PRESS
ENTER";A
305 IF A=1 THEN PRINT"DO OVER":GOTO 5
310 IF A=2 THEN GOTO 315
315 SOUND89,6
320 SOUND176,6
325 SOUND165,6
330 SOUND159,6
335 SOUND140,4
340 SOUND147,6
345 SOUND185,8
350 SOUND125,6
355 SOUND193,6
360 SOUND185,6
365 SOUND176,6
370 SOUND170,6
375 SOUND176,6
380 SOUND197,8
385 SOUND204,6
390 SOUND197,6
395 SOUND193,6
400 SOUND185,6
405 SOUND176,6
410 SOUND165,6
415 SOUND159,6
420 SOUND147,6
425 SOUND185,8
430 SOUND125,8
435 SOUND176,9
440 PRINT" "
445 PRINT"TYPE CLOAD AND PRESS ENTER"
450 STOP

```

No home for PO E-Mail

The information revolution won't be delivered to your door by the U.S. Postal Service if it follows a recommendation in a study by the National Research Council.

In making the recommendation, the council—a private organization that conducts studies at the request of the federal government—concurred with a policy worked out during the Carter administration: An end-to-end electronic delivery system departs too much from the basic character of the postal service and duplicates too closely services being developed in the private sector.

The council, in the report requested by the postal service, recommended the federal agency promote and develop computer-based mail systems to enhance only the physical delivery of messages.

The postal service's fledgling steps in computer-generated mail delivery have come under attack from private firms adverse to competing in the market with an agency unguided by the strict rules of profit and loss. According to some observers, the firms fear the post office will eventually monopolize E-mail.

"On the one hand," the council observed, "we see an opportunity for the postal service to improve its efficiency of delivering messages by use of electronics; on the other hand, we see direct competition with the private sector for this segment of its business."

The group went on to say: "A solution that is being tested in the telecommunications industry is the fully separate subsidiary. Such an approach tends to isolate the costs in order to avoid cross subsidies, but the solution itself is not without cost.

"Too great a separation would eliminate one of the advantages of allowing the postal service to offer electronic mail—the ability to integrate electronic technology into conventional mail handling."

The report added E-mail should be an independent unit within the postal service with a degree of managerial and financial independence from regular mail operations.

Competition from private firms in the E-mail business is accelerating, the report said. It maintained if the post office's electronic services are to remain competitive, the agency must be able to change its rates faster: "It now takes at least eight to nine months for the postal service to adjust its rates. Since the commercial competition is much more flexible, the postal

Mail's a whale of a business

With assets of nearly \$4 billion, the U.S. Postal Service is a big business.

In 1980, it had 650,000 workers, maintained 39,000 post offices, incurred operating expenses of more than \$19 billion and generated \$17 billion in revenues.

Postal workers handle more mail per employee than any other major postal service in the world and—believe it or not—faster and cheaper than in most other countries.

In 1980, 95 percent of the first class mail sent in a local or metropolitan area was delivered overnight; 86 percent headed for an address within a 600 mile radius of origin was delivered within two days; and 87 percent outside 600 miles was delivered within three days.

Postal rates in the United States are less than half the rates in France, Sweden and Germany; slightly greater than half the rates in Great Britain and Japan.

According to the 1976 RCA study, E-Mail could bring mail costs down to \$19.50 per 1,000 letters. In 1978, it cost \$65 to handle 1,000 letters.

However, the National Research Council warned decision-makers to be careful about the RCA study. It predicted E-mail would be handling 20 billion pieces of mail within 20 years, a figure questioned by later studies. The RCA study also maintained that competition from private, end-to-end E-mail providers would be insubstantial.

Not only will competition be fierce, the council contended, but it could hurt the postal service's ability to maintain a competitive E-mail system: "Since employees of the postal service cannot be terminated after six years of service, it could find itself with an overstaffed and overpriced national service whose costs are higher than those of competitors and cannot be easily lowered." ■

service may find its competitors have a six- to nine-month lead."

The council warned the postal service against tying its current experimentation to long-range plans. The electronic mail system that emerges in 20 years, the report said, may not bear much resemblance to the one suggested to the postal service in a study done for it by RCA.

"The postal service should concentrate its efforts primarily on implementing discrete services to test and develop the market," the council recommended. "How far and in what direction electronic mail will evolve from these initial services is difficult to foresee. Hence, the evolution of services arising out of ECOM or other discrete services should not be forced to con-

form to some long-term system design... in advance of operating and market experience."

The report also recommended the postal service consult with its unions' representatives when developing plans for E-mail.

"We wish to emphasize that our concern is not that electronic mail alone will cause labor problems," the report said, "but that its implementation could be delayed because of cumulative labor problems that may, at particular times, require layoffs that cannot be immediately absorbed by attrition."

It went on to note labor leaders "would present no serious obstacle to implement-

continued

E-MAIL *continued*

ing electronic mail or other postal changes. They have all declared that their primary concern is to make the postal service competitive with alternate methods of communication."

Not only do the postal unions "strongly" favor electronic mail, the council maintained, but "the unions are impatient with the slowness with which the postal service has moved."

"They know," the report said of the unions, "that steady employment for their members depends on the continued viability of the postal service. They are prepared to accept fewer jobs that may come with electronic mail in order to increase the postal service's overall ability to maintain or increase its business."

"Postal employees and the leadership of the postal unions appear to have a genuine concern for the welfare of the postal

service.

"This is a valuable resource to be developed and used, for it provides the potential for cooperation with and support for management in adjusting to electronic mail and other changes."

"The postal service should accept at face value the unions' stated desire to contribute to the success of electronic mail. Union participation should take place in the initial stages, when changes are first being considered and planned. It should not wait until concrete proposals have been developed, thereby effectively foreclosing many alternatives and considerations."

Since the postal service will eschew an end-to-end electronic system, the report noted, the most sensitive material the agency's E-mail will be called on to deliver will probably be mailing lists, information on gross revenues and data on contractual actions. In that case, it said, "encrypt-

ing all electronic mail should not be given a high priority."

However, the council said: "The postal service should establish strong internal security procedures for handling electronic messages. These procedures should be designed to prevent any employee or group of employees from browsing through the mails, from aggregating the mail to any one user, or from extracting mailing lists."

"If the postal service markets communications links as part of electronic mail, it should offer to encrypt messages as a special service option."

The council also recommended the postal service be exempted from Federal Communications Commission requirements to journalize electronic mail messages for up to six months. "This requirement seems to be an unnecessary threat to personal privacy," the report observed. ■

It's a cottage techie's dream

Writer's guild formed with home in mind

A corporate president talking like this is a cottage techie's dream:

Our ideal, productive environment is one where the writer works out of his or her home with all the office facilities he or she needs—space, phone, typewriter—and all the amenities for a relaxed and stress-free atmosphere—food, coffee, music, tv. In this kind of environment, we find writers can be at their best.

That cottage approach to technical and business writing, according to Ronald Kandel of The International Professional Writer's Guild Inc., enables his Berkeley, CA, corporation to "go to a client with lower rates than are currently the market average, do a better job in a shorter period of time and cut costs in many areas normally considered labor intensive."

"We want to be the town scribe for the microcomputer industry," Kandel, the guild's president, said. "When a user's guide says written by the guild on it, users will know they are in for a treat."

He noted the guild is aimed at meeting the crying need in the microcomputer industry for documentation accessible to the lay computer user. "We understand the difference between good user manuals," he said, "which make a contact with the user, and bad manuals which don't."

Kandel began the guild in April 1981. He

envisions it growing into a cottage network of mature and experienced technical writers, working with their word processors and telecommunicating their documents to the guild.

According to an essay on the firm, here's how the guild works:

A client contacts the guild. An agent is sent to the client to assess his needs. The agent returns to guild headquarters with the information he or she has amassed and company writers begin the project. They can telecommunicate portions of their work to the guild and the guild can telecommunicate it to the client for his or her comments while the project

communications have become vital.

According to a brochure distributed by the guild, it is looking for a varied clientele:

- Small computer software designers needing user manuals and documentation for their packages;
- Professionals needing office procedures described to their employees or clients;
- Scientists or researchers needing editing, proofreading and polishing of a grant proposal or thesis;
- Small commercial businesses needing brochures describing their product; or

The IPWG's cottage approach to technical and business writing enables the firm to go to clients with rates below market average.

is in progress.

The final product can be sent to a client in any form: word-processed final draft, camera plates from a phototypesetter or as printed documents ready for distribution.

The guild will not be limiting itself to microcomputer clients. Kandel expects to be working in any field where clear com-

- Data processing departments needing operations manuals for their applications systems.

Kandel said his venture will be open to all kinds of writers, too, but right now he is looking for experienced scribes with backgrounds in data processing, microcomputers, medicine, law, government and research. ■

Hyperlight Patrol

We appreciate this opportunity to tell you about Hyperlight Patrol. Written by Warren L. Greene for a 48K Disk TRS-80, this unique program provides sound output via the cassette port and voice output for a Radio Shack Speech Synthesizer. The latter is not required for play.

In Hyperlight Patrol, your single Star Cruiser must locate and if possible destroy a fleet consisting of unknown numbers of four different classes of enemy ships. Unlike the Klingons, Cylons, etc. of most space games, these enemy ships maneuver intelligently in the three-dimensional space around you and can move as you do by hyperlight jumps. They have, as you do, many systems which can be disabled or destroyed. Your ability to recognize and capitalize of their damage, while maneuvering to minimize the effect of your own, can be a key element in your victory or defeat.

To help you overcome the numerical odds, your ship is "human engineered" with systems which can automatically follow or fire on targets you designate, can maintain your shields within the limits of your energy banks, and can signal when hostile ships appear within weapons range. Sound effects and visual displays indicate damage, weapon status, alarms, etc. and help you input commands.

The author is an expert in war-games and war technology. His intention in writing this program was to produce a conflict simulation which would realistically create the command environment of a ship's captain in the distant future. He has tried to avoid the torpedo-course-guessing and hand-eye coordination elements so common to today's science-fiction games.

The viewscreen you work from also reflects this philosophy. As in a real conflict the enemy can be all around you, and you can see exactly this in the "projection-map" display. A totally new concept in TRS-80 games, this display continuously updates the position of each enemy ship as they circle you, close in, or try to escape. Our screen is of course flat and two-dimensional, like a wall map of the earth, but within the limits of TRS-80 graphics it will show you the "globe" of space around you - front, sides, back, above, below, etc.

The action in this sphere is real-time. Again as in reality there are periods of rest and inaction, punctuated by bursts of tactical scrambling. To survive and score, you must constantly evaluate the strengths, weaknesses, speeds, and relative positions of your own ship and the enemy. The information presented to you is purposely kept brief so that you can handle it. The computer takes care of the great complexity of the simulation, as it should, leaving to you only those decisions requiring intelligence and judgement.

This is not a trivial or an easy game, but it is addicting and fun to play. You must be prepared to learn by experience the best strategies and (a completely different question) the best tactics. It will take some time for you to become familiar with your ship and with the mechanics of the simulation. There's a lot going on in the 28K of code that you will not immediately appreciate. Don't let this be discouraging. Everything here has a reason and as you become more proficient at the game, you will find yourself turning former weaknesses into present strengths.

Certainly Hyperlight Patrol is not the be-all and end-all of space conflict games. Remember that it is first and foremost a simulation. One could write a game with more graphics. One could write a game with more action, or more sound, or whatever. And any of these could nevertheless be conventional and dull. Hyperlight Patrol is different. It offers you a creative and challenging blend of all these ingredients in a completely unique and pace-setting format that will literally boggle your mind. You have never seen anything like it on the TRS-80, and if you enjoy a good game, you will surely get many hours of pleasure from this one.

Thank you for your interest and your time.

HYPERLIGHT PATROL

by Warren Green

Price: \$19.95 48K Disk Model I & III
SEE YOUR LOCAL DEALER
DEALERS INQUIRIES INVITED

FANTASTIC SOFTWARE
P.O. BOX 27734
LAS VEGAS, NEVADA 89126
(702) 362-1457

Mags for high octane micros

Pennsylvania and California firms hitch their wagons to new stars and target new mags at Tandy's Model-16 and the Big Blue's Personal Computer

Magazines for the IBM Personal Computer and the TRS-80 Models II and 16 have been launched in San Francisco and Lancaster, PA.

The 102-page maiden issue of *PC/The Independent Guide To IBM Personal Computers* came out early this year. By August the magazine expects to be a monthly, according to Publisher and Editor-in-Chief David Bunnell.

An article in the *Wall Street Journal* suggested the plural reference to the Personal Computer in PC's name indicated the editors were banking on the predictions of some analysts that IBM may introduce a new model of its micro by the end of the year or the beginning of 1983.

That's not the case, Bunnell told *80 Micro*. The plural reference, he explained, was used more out of design and typography considerations than the magazine having an inside track on proposed developments.

"IBM is very close-lipped about these things," he said. "Our use of personal computers was based more on semantics than inside knowledge. It's not that we had inside knowledge, but rather general knowledge of the personal computer market."

He added, however, PC editors feel IBM eventually will introduce new Personal Computer models, possibly one with a built in color monitor and a portable one. He said his personal feeling is "I don't believe they will come out with another machine for two years."

Meanwhile, in the Keystone State, Richard H. Young is starting up *11/16*

magazine aimed at owners of Tandy's glamor machines. "We feel this area has been neglected by magazines like *80* and *80 US*," he maintained.

Young, a CPA and financial analytical systems consultant, told *80 Micro* the first issue of his bi-monthly will be May-June. It will have 24 pages of editorial content. Although changes will be made from time to time, he noted, "it will continue to look like a technical journal" and its covers will display the issue's table of contents.

Articles in the first issue include how to

patch WordStar to work with Epson printers and the complete specs on the Model 16 and what they mean.

Young said he will be promoting *11/16* through advertising in magazines like *80 Micro* and through a direct mail campaign using a mailing list rented from H&E Comptronics. Sample copies of the magazine will be distributed to computer stores, he added.

He said subscriptions to the magazine are \$30 a year and the newsstand price is \$5.95. ■

Prestel boon to microphiles

by Michael E. Nadeau

80 Micro staff

Prestel, the British videotext system, was introduced into the United States in January. Its sponsors are targeting business and users groups, but it appears micro owners will gain as well from this latest invasion from the isles.

The data bases on Prestel are heavily oriented toward business, and include commodities listings, stock market reports, and airline rates and schedules. *Newsweek* magazine also supplies a data base consisting of an abbreviated electronic version of each weekly issue. Other American data-base suppliers include: Merrill Lynch, *The Wall Street Journal* and American Express. The BBC, London Stock Exchange and *The Economist* are among the international providers.

The data is transmitted to the United States via satellite. The data bases can be accessed within this country through a Telenet number over phone lines. A terminal, monitor and modem are the basic hardware requirements for user access. There are eight sources for Prestel terminals in the United States; Zenith is among them.

Anyone with a microcomputer, however, can potentially access Prestel. Software is available for the Apple II, called Appletel, from Logica, a New York-based company and a sponsor of Prestel in this country. Apparently, software for the TRS-80 is not far behind. At a Prestel demonstration at Babson College in Wellesley, MA, a spokesman alluded to the ex-

istence of prototype software for the TRS-80 Model II and Color Computer. Allan Hewitt, sales manager at BVT (British Videotext and Teletex, Prestel's parent company) was reluctant to give details about this software, calling it "commercially confidential. It would be silly to ignore [the TRS-80]," he said, admitting only that software is being written.

Hewitt also mentioned that terminal software will be available for Commodore computers by the end of this year.

Once a micro owner has the needed software and peripherals, he or she must pay Prestel a \$50 monthly fee plus a 30-cent-per-minute charge for connect time and a 15-cent-per-minute charge for phone line time via Telenet. This price will limit the number of individual users, but Hewitt said his company hopes to provide enough different services to make Prestel attractive. He suggested the home user may soon be able to do his banking and shopping, get up-to-the-minute news and weather reports and, in idle moments, play video games on his Prestel terminal.

Prestel is aiming at the business market because, obviously, that is where it will be most easily sold. But Hewitt claims that once Prestel is established in business, the businessman will start bringing the terminals home with him. Eventually, videotext and Prestel will be seen as more than a business tool, he said. "We want the man in the street to think of his videotext terminal the same way he does his television set...to become something that [naturally] sits in the corner of the living room." ■

Writing without disk drives

by G. Bert Latamore
Contributing Editor

Using word processing is like losing your virginity, you'll never go back to what you did before.

So says Ernie Hebert of Keene, NH, *Boston Sunday Globe* columnist and author of two novels and a third about to go to his publisher.

Hebert spent three years part-time on his first novel, *The Dogs of March*. He switched from typewriter to Radio Shack's Scripsit and did his second, *A Little More Than Kin*, also working part-time, in a year on a Model I. When it brought him a hefty advance, he quit his job to write full time.

"I wanted to get away from computers," he revealed, "The Model I kept going down, and I had to keep bringing it back to be fixed. So I sold it, bought an IBM Memory Typewriter and tried to write on that. I couldn't."

He replaced the IBM with a 32K Model III, a Line Printer VII, Scripsit and a tape recorder. Apparently it was what he needed; he finished the 70,000 word first draft of his third novel, a psychological thriller titled *The Viceroy*, in three months.

He hopes to finish the final draft by June and know by August whether it will be accepted. That's an important deadline for him because he has enough money to last until September. If the new novel doesn't sell by then, he will have to take a job and go back to part-time writing.

Although his system is minimal and lacks disk drives, Hebert is satisfied with it.

"I wanted to get the cheapest adequate word processor I could, and I find that for \$1,600 I have it," he said. "Everything I've heard about word processing says you have to have disk drives, but really for the creative artist they are a luxury you can live without."

Hebert loads Scripsit off the tape first thing every morning. It takes exactly three minutes. He keeps the machine on—even when he walks the block to Keene State College where he teaches part-time—until bedtime.

"I pretty much write all the time, and I don't use the computer for anything else," he explained.

He developed a special format giving exact control of the number of lines on a page. When he has written and polished a page he saves it on tape, which takes 23 seconds, and prints it out. He logs the page's location on the tape, clears the

photo by Bert Latamore



Ernie Hebert, *Boston Globe* columnist and author of three novels, says creative writers can get by with CLOADs.

screen and starts the next.

Using that system he produces three to ten pages a day, which, he commented, is "incredibly swift for me."

Speed does not guarantee quality, however.

"I think the danger in word processing is working too fast. You tend to get into the groove of cranking out words. It encourages verbosity."

To slow down, he decided to type his final draft, copying the text off the screen and stopping to revise rough passages on the computer.

"I just started working this way," he explained. "I find I have to be flexible with my working methods. What worked last week might not work today."

Having a printout is important to Hebert. "I'm very visual," he admitted. "Seeing pieces of text on the screen and seeing the hard copy are different things. You can't look at the whole work on the screen, so you tend to repeat words and become repetitious in sentence structure."

Hebert and his agent have discussed submitting manuscripts in electronic form, but he questions the practicality of the idea.

For one thing, book editors do a lot of their reading and copy editing commuting to work or at home, places where they wouldn't have access to a computer.

The electronic manuscript also could take control over editorial alterations away from the author.

"When an editor makes changes on my manuscript, I see exactly what he did when I get it back, and we can talk about it," Hebert expounded. "If he were working on a word processor I might not find the changes."

Although he is not happy with his present printer—the tractor feed has never worked right—Hebert does not see a major problem with editorial acceptance of dot matrix print.

"From what I know of editors, they don't care what the manuscript looks like as long as they can read it," he opined.

In fact, Hebert writes his weekly column on New Hampshire life entirely on his Model III on Sundays.

"I try to make each one come out to exactly 4090 characters," he mentioned.

The television and radio, situated in his study next to the computer, pick up Interference from the Model III, he said, but that doesn't concern him.

The Model III also has brought a new magazine into his life, *80 Micro*.

"I always buy it. I don't type the programs in, but I enjoy reading about them," he explained.

For Hebert the Model III is a useful tool, but it doesn't do everything.

"Being a novelist is a risky business because your writing depends on this X factor in the back of your brain, and you always fear it will just go away. For a lot of writers it does. They write one novel or five or 12 and then just stop. It really is a muse." ■



photos by Kerry Leichtman

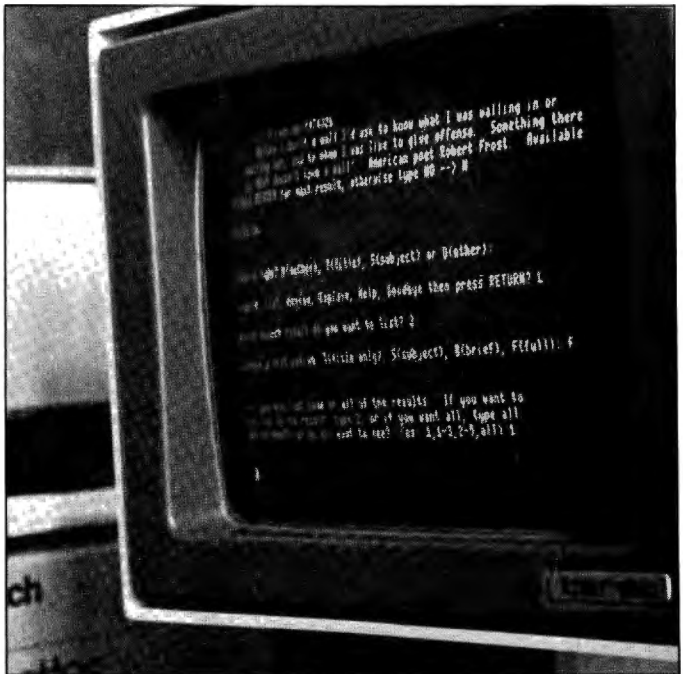

Emily Fayen (left) and Margaret Otto (right) are two developers of a computer system at Dartmouth College linking hundreds of terminals to the school's half-billion volume library. Photo on right shows how library information is displayed.

Dummies growing in the ivy

by Kerry Leichtman
80 Micro staff

For an Ivy League school, Dartmouth sure has a lot of dumb terminals. But when Dartmouth College in Hanover, NH, goes on line with one of their latest computer innovations those terminals will seem much smarter.

This new system will connect, through a 580 million-byte data base, hundreds of on-campus terminals to Dartmouth's vast 1 1/2 million volume library. By the time the system is up and functional sometime this summer, 450,000 of the library's 800,000 titles will be stored in a pair of DEC minicomputers.

The system is being developed by William Arms, Dartmouth's director of computing services; Emily Fayen, director of library automation services; and Margaret Otto, Dartmouth College librarian. Although other institutions such as Northwestern University, the University of California and the Library of Congress have computerized library systems, Dartmouth's is unique in its approach.

"We wanted to put up a system that could be used by any student using our library," Fayen explained, "We are trying very hard to make it comfortable to anybody." Most Dartmouth students are computer literate, so the system's designers do not anticipate any of them freezing at the keyboard. But even so, the emphasis is on developing user-cordial prompts.

What this means is that the computer knows there is no difference between Frost, Robert and Robert Frost. Entering the poet's name in either format will get the user to the author's work. However, Bobby Frost probably would not.

The pride of the system, according to its developers, is its search capabilities. "Northwestern's system," Fayen told *80 Micro* during a visit to the Hanover campus, "is a computer analog of the card catalog. It does no more and no less. Ours has considerably expanded search capabilities. You can get at any word in the title, you can look for the illustrator, a certain person as the translator. Essentially, we've made the whole record searchable."

Using Robert Frost again as an example, the user might want to look up only Robert Frost poetry written in New Hampshire before 1950. More specifically he might want only pre-1950 New Hampshire poetry with "winter" in the title.

One of the graduate assistants working on the project offered to look up something more obscure for us; a song called "Slide Frog Slide." Moments later the screen was full of information about a George Lewis and Punch Miller's Bunch album called *Jazz at Preservation Hall, III*. Besides giving Lewis' dates of birth and death, the album's library catalog number, its record company release number and a host of other related information,

there it was—cut one, side one, "Slide Frog Slide." The album's program notes, by the way were written by Thomas Sanction. Who cares? Someone might and if they do, it's all right there.

The system will also make using the library more convenient. A professor can be sitting in his office, or a student in a dormitory, turn on a terminal and do library research. After finding the books, magazines or records they can check them out using the terminal and pick them up at a more convenient time. The system will even send notices to persons in possession of overdue books.

Emily Fayen came to the library project via her work with computers. Margaret Otto, on the other hand, is a librarian, with training in the Decimal System rather than silicon chips. "I think it's just great," she told *80 Micro*, "What the computer can do for us is provide better information for the end-user. We are not trying to duplicate what we have in our catalog, we're trying to produce a product that's better than the card catalog.

"The system is going to give the researcher, the scholar, the library user capabilities that they simply don't now have," she continued, "They won't have to run to the library and spend hours going through the card catalogue. It's much more efficient. It's a real step forward in terms of ease of usage of the library itself. That's what I'm very excited about." ■

Introducing T80-SG2

Forest Fire Dispatcher from SubLOGIC

Forest Fire Dispatcher combines the complex challenge of a realistic simulation with the ease of operation necessary to allow you to concentrate all your energy and imagination on the job at hand.

You are the forester in charge of a district in southeastern Kentucky. Your objective is to save the maximum possible acreage from fire at the least possible cost. Situation variables include the number of fires presently burning, acres already burned, acres threatened, fire spread rate, terrain difficulty, weather conditions, the number of men assigned to each fire, and the previous experience of your crew leader.

T80-SG2 Forest Fire Dispatcher is available on cassette and disk. Both versions contain a 50 minute game. The disk version also includes a longer lasting pure simulation. Your situation can be saved to disk at any time. This allows you to build a history of yourself as a dispatcher and improve your performance record over the course of several fire seasons.

T80-SG2 Forest Fire Dispatcher . . . a naturally deep strategy game designed to provide you with years of pleasurable interaction.

If you've never been into strategy games before, buy this one.

\$24.95 on cassette (16K required)
\$29.95 on disk (32K required)
Specify Model I (Level 2 BASIC) or Model III TRS-80

See your dealer!

For direct order please specify whether you have Model I or Model III (the media are different) and whether you want disk or cassette. Include \$1.50 and indicate UPS or first class mail. Illinois residents add 5% sales tax.



subLOGIC

Communications Corp.
713 Edgebrook Drive
Champaign, IL 61820
(217) 359-8482
Telex: 206995

Cassette owners may update to disk at any time by sending in the cassette and \$6.50 (no manuals please) postage paid.

Future bright for home banking

The bank of the future may be in your tv set.

According to a Cambridge, MA, consulting firm, eight million households will be doing video banking from their homes by 1990.

In a statement on a 230-page report on telebanking distributed privately to 75 of its clients, the Yankee Group predicted the new banking will enable financial institutions to offer consumers "money management tools previously available only to corporate cash managers."

Offering these services will be a future necessity, the statement said, if thrift institutions are to compete with money market funds. Today, 15 percent of all consumer deposits are in those kinds of funds.

Telebanking will also encourage non-banking firms to vie with banks for consumer deposits, Yankee predicted.

It maintained Sears Roebuck Co.'s recent purchase of a brokerage house (Dean Witter Reynolds Inc.) and the nation's largest real estate firm (Coldwell, Banker & Co.) is a sign it intends to move beyond retailing into consumer financial services.

Sears will start by selling money market funds, Yankee noted, and later install automated teller machines and function as a true depository institution.

It said a major role in telebanking will be played by three major computer service bureaus—Tymshare Inc., Automatic Data Processing Inc., and General Electric Information Services—but no single elec-

tronic network vendor will dominate the market.

The three service bureaus will try to become "super service bureaus," the consulting firm claimed, and either sell their capabilities to banks or acquire depositories and deal directly with the public. Meanwhile, it added, Citicorp, American Express, Visa, Mastercard and various bank consortia will be trying to build their own electronic-payment pipelines.

It maintained Citicorp of New York is the most aggressive U.S. developer of video home banking. Citicorp hopes to "cream-skim" high income individuals nationwide, it added, inviting them to manage their money and make investments on-line from their homes at any hour—not

just bankers' hours.

Yankee expects Citicorp to offer its home banking service in 1983. The service could include funds management, tax planning, records keeping, "what-if" analysis of financial decisions and information from Dow Jones & Co.

Also in 1983, the consulting firm stated, AT&T may roll out a video-based information utility allowing smaller banks to penetrate the home market and compete with national financial institutions.

Yankee added telebanking will win acceptance first with the "computer comfortable" people and later as part of systems like Viewtron, Venture One and AT&T's EIS which will begin to penetrate the market around 1986. ■

RECENT VIDEO HOME BANKING TESTS

Citicorp: Homebase

"100-user test" of Homebase is now under way in Queens NY. It features proprietary terminal, card reader, and dedicated 5-1/2" black-and-white CRT, all developed by Citicorp's subsidiary, Transaction Technology Inc. of Los Angeles.

Chemical Bank

Project Pronto free trial in 200 homes in metro NYC, will run 3 months beginning in late 1981. Uses Atari 400 computer, TV set, autodialer. Will probably include banking and other services.

Bank One Corp: Channel 2000

A primitive system done largely for promotional purposes, was tested in 130 households for 11 weeks.

POSITIONING OF LEADING PLAYERS FOR CONSUMER FINANCIAL SERVICES MARKET

	Citicorp	Sears	American Express	Bank Card Associations (Visa, Interbank)	Merrill Lynch	Service Bureaus (ADP, Tymshare, Gaisco)
Proprietary Card	Citicard, Carte Blanche, Diners Club	48 Million Sears Cards	Green Card, Gold Card (13 Million)	Visa, Master Card, (40 MM +)	No	No
Asset Management (CMA-Type Service)	"Personal Banking" under development	"Active Asset Account" (Dean Witter subsidiary)	Yes, through Shearson Loeb Rhoades subsidiary	Under development (Master Card, Money Manager, Etc.)	CMA	No
Proprietary Depository Institution	Citibank	Allstate Savings & Loan, etc.	No, (Uses Provident National Bank of Philadelphia)	Yes (owned by banks)	No (uses Bank One of Columbus)	No
Related Financial Services	Person-to-Person, shelter loans, Travelers Checks, etc.	Allstate Insurance, Coldwell Bank, (real estate), Dean Witter, (brokerage)	Shearson Loeb Rhoades (brokerage), travelers checks	No must make deals (i.e., Master Card + Fidelity)	Brokerage	No
ATM/EFT Network	NYC (regional) & INCA (national)	Will develop in-store ATM's?	Has own ATM's & Express Cash network	Both have proprietary networks (BASE & INAS; INET)	No	Yes
Financial Strength (Assets)	\$114 Billion	\$23 Billion	\$23 Billion	Limited	\$13 Billion	Limited
Aggressiveness	High	High	High	Medium	Medium	High

Source: The Yankee Group

How to Buy or Sell Computer Equipment and Software

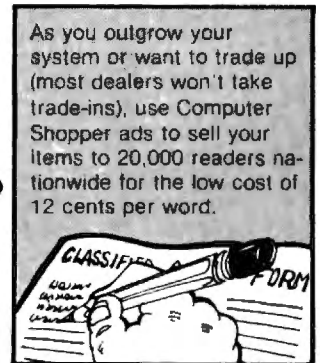
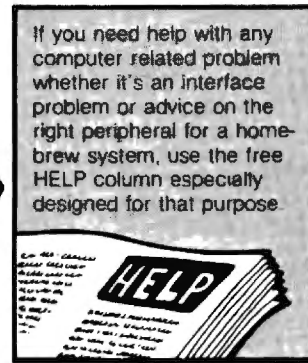
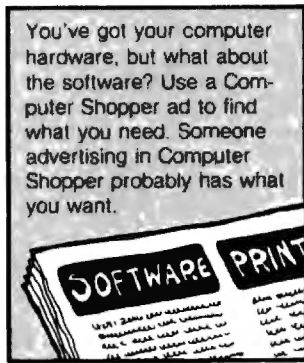
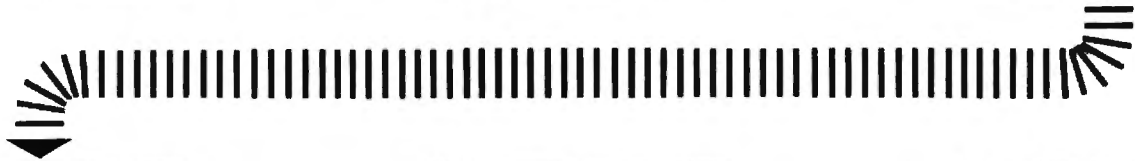
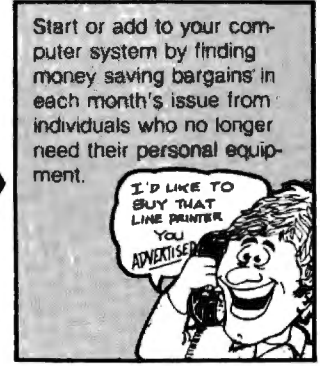
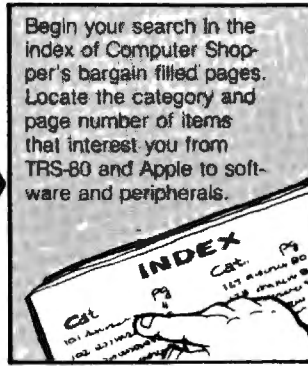

Computer Shopper is THE nationwide magazine for buying, selling and trading Micro and Mini-computer equipment and software. Each issue has over 60 pages full of bargains of new and used equipment.

You can save hundreds of dollars by getting the equipment you need from the hundreds of classified ads individuals place in Computer Shopper every month.

Now is the time for you to join over 20,000 other computer users who save time and money with a subscription to Computer Shopper.

Subscribe today and get your first issue and a classified ad absolutely FREE. Type or print your ad on a plain piece of paper and send it along with your subscription.

Just fill in the coupon or MasterCard or VISA holders can phone **TOLL FREE 1-800-327-9920** and start making your computer dollar go further today.

Cut out and mail to: **COMPUTER SHOPPER**
P.O. Box F319 • Titusville, FL 32780

Yes, I'll try Computer Shopper, I understand that if I'm not satisfied with my first issue I can receive a full refund and keep the first issue free.

- 1 year \$10.00 (\$30.00 in Canada)
- I have enclosed my free classified ad
- I want to use my free ad later, send me a coupon

NAME: _____

ADDRESS: _____

CITY: _____

STATE: _____ ZIP: _____

 **COMPUTER SHOPPER**
P.O. Box F319 • Titusville, FL 32780
Telephone: 305-269-3211

✓ 39

PULSE TRAIN

Software to go

The McDonald's Era has arrived in the computer retail business.

A Palo Alto, CA, company is peddling software a user can take home and try out before he or she decides to buy it.

Software from Ico-Rally Corporation contains a demonstration program and main program protected by a "Soft-Lok." If a user, after trying out the demo program and reading the documentation, wants to buy the software, he or she tells the retailer. The retailer calls Ico-Rally via a toll-free number and gets the code to open the Soft-Lok.

The system is a boon to retailers, too, maintained Bill O'Brien, National Sales Manager for Ico-Rally. He said, "Retailers are leery of software because of its quality." Rather than force dealers to tie up cash in expensive inventory, they may buy Ico-Rally programs for the cost of the demo program—\$49.95. When the program is sold, O'Brien explained, the proceeds are split with Ico-Rally. According to a statement from the firm, the arrangement offers dealers more than a 300 percent return on inventory investment.

The whole idea behind the program is self-service, O'Brien said. To aid users, Ico-Rally also provides users with software support via an 800 telephone number and a free monthly publication to chronicle software developments.

Asked what the chances were Soft-Lok would be picked by a deft soft-buckler, O'Brien said the developers of the access locking technique estimate if a price tag were placed on the number of man hours needed to break the code it would amount to \$10,000. He contended a software pirate would think twice before spending that much time to steal a \$300 to \$600 program.

Court rules video games covered by copyright

A federal appeals court in New York City has ruled authors of video games may copyright the sound and appearance of their games.

According to a report in the *Wall Street Journal*, the three judge appeal panel upheld a preliminary injunction issued by a federal district court, which

found video display designers are entitled to the same copyright protection as book authors and music composers.

After delivering its finding, the appeals court returned the case to the district court for trial. An attorney for Stern Electronics Inc. of Chicago, the plaintiffs in the case, told *80 Micro* it could take anywhere from three months to a year before the case is tried.

The *Journal* quoted David Shoenberg, vice president and general counsel for Stern, as saying the decision was "a landmark case for the industry" because it is the nation's first appeals court ruling on video copyrights.

The Illinois firm alleges a Rhode Island concern, Omni Video Games Inc., copied Stern's *Scramble*, a game where a player maneuvers his or her rocket ship through electronic obstacles—ground-air missiles, buildings and cannon fire.

Booming video game market

This year more than half a dozen companies plan to introduce home video games and sales are expected to reach \$3 billion, according to a report in the *Wall Street Journal*.

Companies are scrambling to enter the market and with good reason. A successful game like Atari's *Space Invaders* can generate \$100 million to \$150 million in sales, with margins of about 20 percent.

Atari, expected to double its advertising budget this year to \$75 million and release a \$349 super game, has cornered 75 percent of the market, Mattel 15 percent and Odyssey, marketed by the Magnavox division of North American Philips Corporation, 9 percent.

Meanwhile, during a press conference announcing the formation of a cable-tv company by CBS and 20th Century Fox, a spokesperson for the network said the new firm would produce a wide range of products for home video systems and development of home video games "could not be precluded" from the firms' plans.

Eighty million households in the United States have televisions, but only 8.5 percent have video games. The *Journal* said industry experts predict 50 per-

cent of the households, however, will have video games by 1985. And the European market has just opened up, with a million consoles sold so far there.

The business newspaper also reported many analysts believe the sales of home video consoles will give way to the sale of home computers that can be used for games. If that happens, many of the companies that offer hybrid game and computer systems—including Mattel, Commodore and Coleco—will have to compete with giants like Tandy Corporation and IBM.

"Intellivision will do well as long as there is a strong video game-only market," one analyst told the *Journal*, "but when the home computer comes into play, Mattel and a lot of these newcomers may be in trouble."

Sears to open 45 new computer stores

The success of five computer stores opened by Sears, Roebuck and Co. last fall has spurred the concern to gallop deeper into the retail micro business.

Edward A. Brennan, chairman and chief executive officer of the Sears Merchandise Group, said in a statement: "The performance of these five test stores has exceeded our expectations. The test clearly demonstrates the potential for such retail specialty stores in the rapidly expanding field of electronic business equipment."

Although Sears declined to reveal sales revenues from the new stores, a spokesman told *80 Micro* the firm expected a greater return on investment from the stores than its other retail outlets.

James L. Podany, director of marketing communications, also noted the stores "have been able to keep up with all customer demand for product" including orders for the IBM Personal Computer.

The 45 new Sears business systems centers will be located in the test areas and in 17 new markets including Los Angeles, San Francisco, Atlanta, Washington, Miami, Houston, Detroit, New York, Philadelphia, Seattle and Denver.

107,000 square feet for the Color Computer

Radio Shack said it will open a

continued

Houston's Software Store • Micro Solutions, Inc.
Color Computer Software • Model I • Model III • Model II & CP/M

Communications Programs •		
Color Computer Model I or III	Rompack that allows your printer to be used with your modem. Allows downloading to tape. Intelligent terminal program easy to use. Allows downloading and uploading (Disk)	\$59.95 \$149.95
Games •		
Color Computer Model I or III	Rompack "Star Blaster" action packed machine language high res. graphics (Requires 16k) Arcade games Meteor Mission 2, Galaxy Invasion, Robot Attack, Cosmic Fighter (Tape/Disk) and more. Send for list	\$39.95 \$16.95/20.95
Accounting Programs •		
Model III	General Ledger 400 accts. 1000 transactions/month. allows for departmental income statement Accounts Payable 400 accts. 1000 transactions/month. and 99 department codes Accounts Receivable 400 accts. 1000 transactions/month. and 99 department codes Payroll 400 employees weekly. bi-weekly, monthly, salaried, hourly. 2 misc ded	\$199.95 \$199.95 \$199.95 \$199.95
Model II	Available for floppy or hard disk. Capacities below are for 2 floppy drive systems General Ledger 5000 accts. 2000 transactions/month. allows for departmental income statements Accounts Payable 2000 accts. 5000 transactions/month. and 99 department codes Accounts Receivable 2000 accts. 5000 transactions/month. and 99 department codes Payroll 2000 employees weekly. bi-weekly, monthly, salaried, hourly 2 misc ded	\$499.00 \$499.00 \$499.00 \$499.00
In Houston 9949 E. Harwin Houston, Tx. 77036 (713)-789-5443	VISA/M/C Accepted Prices include handling and shipping	In Florida P.O. Box 271793 Tampa, Fl. 33688

362

EDU-WARE EAST
P.O. Box 336
Maynard, MA. 01754
617-568-8641

MATH-PAK-1: MATH-PAK-2: MATH-PAK-3

Interactive drill programs where you enter the answers digit by digit, just like paper and pencil. With user selected difficulty levels, carryovers, reducing, simplification, pointing off, scoring, games, and more. Used by schools everywhere. Order MATH-PAK-1 for integers, MATH-PAK-2 for fractions, MATH-PAK-3 for decimals. (L2-16K) \$14.95 ea.

H-O-R-K-S

Low cost, single entry accounting system for the home or office. With 95 user assigned account codes, auto audit trail, search with totals, 32 or 48K, 1 to 4 drives, credit and debit summaries with 3 options, up to 9200 entries. \$24.95/cassette \$29.95/disc

INVENTORY +

Why settle for just an inventory listing? Get aging reports with 2 options, reorder, total listings with purchase dates and amounts, total costs, items sold, profit/loss and more. Use as a stand alone system with daily updates, delete, change, and file packing routines. (32K - 1 disc minimum) \$24.95/cassette \$29.95/disc.

CASH REGISTER 80

Use your TRS-80 as a point of sale terminal with automatic inventory lookup, pricing, update, and more. Print sales slips with user adjusted formats, end of day reports with all cash, charge, and check sales by salesperson. CR80 requires INVENTORY+, 48K, and 1 disc minimum (2 drives recommended). \$24.95/cassette \$29.95/disc.

Mass residents and 5% tax. VISA, M.C., AND PHONE ORDERS ACCEPTED. Dealer inquiries invited. Overseas orders add \$2.00 for air shipment. TRS-80 is a trademark of Tandy Corp.

SAVE YOUR CLOAD WITH THE "DATA CONDITIONER"

Exclusively From Communications Systems Labs

TIRED of CLOAD troubles with prerecorded tapes? Are CSAVEs a headache? USE THE DATA CONDITIONER TO:

- Copy system and data tapes without your computer.
- Eliminate noise and minor dropouts.
- Signal condition in both directions-loading & saving.
- Operates at ALL TRS-80 baud rates (Mod III high speed too!).

RUGGED CONSTRUCTION-AC POWERED-DESIGNED & MADE IN THE USA
Introductory Price \$59.95 (post paid) through April 30, 1982 ORDER TODAY!
Phone Order?... Use your VISA, MASTERCARD or AMERICAN EXPRESS

write **COMMUNICATIONS SYSTEMS LABORATORIES** call **(808)-677-3380**
94-165 Leokane Street, Waipahu, HI 96797 361

DISCOUNT PRINTER RIBBONS

Brand New, Top Quality, Exact Replacement Ribbons & Cartridges. These Ribbons Produce Super Jet Black Impressions and Ultra Reliable Print Life. They Are Delivered to Your Door Promptly for Much Less Than Most Retail Stores

★SPECIAL! BUY 10 and GET ONE FREE!

YOUR PRINTER	PACK SIZE	RETAIL LIST**	YOUR WHOLESALE PRICE	SIZE	COMMENTS	CAT. ORDER#
ANADIX 9000 Series	1 pk	14.00 ea	14.00 (14.00 ea)	500	Nylon Jet Bk	C-777
CENTRONICS 700-703, 737, 779	3 pk	18.95/3 pk	11.95/3 pk (3.98 ea)	563" x 45"	Nylon Jet Bk	C-700
CENTRONICS 100, 101A, 102, 103, 300, 301, 306, 308, 330, 358, 398, 500, 501, 503, 508, 588, 620, 820	3 pk	26.33/3 pk	17.55/3 pk (5.85 ea)	1" x 108"	Nylon Jet Bk 5 ml High Speed	C-100
CENTRONICS 704-705	1, pk	16.95 ea	13.95/Giant Cart (13.95 ea)	5 16" x 210"	Giant Cart	C-7045
DEC 1/2 x 40YD	3, pk	17.77/3 pk	12.95/3 pk (4.32 ea)	1 2" x 120"	Double Spools	R-800
DEC 1/2 x 80YD	3, pk	20.12/3 pk	14.25/3 pk (4.75 ea)	1 2" x 180"	Double Spools	R-844
DIABLO HYTYPE II (M/S BLK) HI YIELD, FITS 70 PRINTERS!	1, pk	9.31 ea	6.87 ea (6.87 ea)	5 16" x High Yield	300,000 plus imp	C-511
EPSON MX70 80	1, pk	16.00 ea	16.00 ea (13.95 ea)	500" x 80"	Nylon Jet Bk	C-522
IBM "SILVER DOLLAR" Sys 34, Sys. 32 MDLA, Series IMDL4974, 5256, 3287, 3770, 3771-3774, 4974, 5100, 5103, 5110, 5228, 5256, 5320MDLA	5, pk	5.80 ea	14.90/5 pk (2.98 ea)	9 18" x 30"	Nylon Jet Bk	R-300
IBM - HARMONICA 1/2" SERIES I MOD 4873/II, 3200, 3289, MOD 2	3, pk	9.42 ea	20.85/3 pk (6.95 ea)	1 2" x 108"	Nylon Jet Bk	C-350
NEC SPINWRITER QUME (FITS 80 PRINTER MODES)	4, pk	23.40/3 cart	23.60/4 pk rb reload (5.90 ea)	1 2" x 51"	Nylon, Ex Eng. Life	R-400
RADIO SHACK DAISY WHEEL II	3, pk	18.00/3 pk	13.95/3 pk (4.65 ea)	1 4" x 310"	Multistrike Film	C-525
RADIO SHACK LPH, LPV	1, pk	24.95 3pk	8.25 (18.25 ea)	250"	Mylar Multistrike	C 789
RADIO SHACK LPH, LPV	one pk	13.95 cart	8.95/Reload rb only (8.95 ea)	500" x 45"	Nylon Incl Instr	R-T3
TELETYPE MOD 33, 28 35 37 38, 88	3, pk	18.95/3 pk	11.95/3 pk (3.98 ea)	563" x 45"	Nylon Jet Bk	C-700
WANG M.S. 5541W, W.C. 5581, W.D. 6581W, 2281W	10, pk	2.40 ea	13.90/10 pk (1.39 ea)	1 2" x 36"	Nylon Jet Bk	R-450
	1, pk	6.85 ea	5.95 ea (5.95 ea)	5 16" x 393"	Multistrike Film	C-550

40% OFF!! OR MORE!

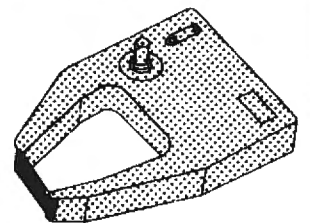

TERMS:

MINIMUM PURCHASE - \$20
PAYMENT BY: C.O.D. (UPS), CHECK, MASTER CARD, OR VISA CHARGE CARD.

VOLUME DISCOUNTS:

20 - 50 PACKS 10%
51 - 100 PACKS 15%

*UNDER \$20, ADD \$5 HANDLING.

**APPROX. RETAIL. PRICE VARIES.

ANCIE LABORATORIES

5200-J Philadelphia Way 301-345-6000 (Wash. D.C. Local)
Lanham, Maryland 20706 301-792-2060 (Balto. MD Local)
800-638-0987 (National)

NAME _____
ADDRESS _____
CITY _____ STATE _____ ZIP _____

QTY CAT.# AMT.

TOTAL _____

Check Enclosed
 C.O.D.
 VISA
 MASTER CHARGE
ACCT. # _____
EXP. DATE _____
MIN. ORDER \$20
PRICES SUBJECT TO CHANGE

ANCIE Laboratories 284 301-345-6000 (Wash. D.C. Local)
5200-J Philadelphia Way 301-792-2060 (Balto. MD Local)
Lanham, Maryland 20706 800-638-0987 (National)

PULSE TRAIN*continued*

107,000-square-foot plant to manufacture the Color Computer and will convert the 40,000-square-foot facility currently producing Color Computers and use it to manufacture its eight-inch hard-disk drive.

The company also announced it is building a new 135,000-square-foot building for software assembly and is converting the old 39,000-square-foot software plant into warehouse space.

Both new plants will be in the Fort Worth area. The new computer plant is expected to be occupied early this spring.

Mexico tells computer makers to put up or get out

If U.S. computer makers want to tap into the estimated half billion dollar Mexican market, they're going to have to start manufacturing their wares south of the border.

According to a report in the *Wall Street Journal*, the Mexican government will start decreasing U.S. computer imports this year. The move is aimed at decreasing computer imports while nurturing native industry.

If a microcomputer maker wants to continue doing business in Mexico, it will have to take a minority interest in a Mexican firm. The *Journal* quoted Robert Lynch, senior vice president of Tandy Corporation's Radio Shack division, as saying:

"I have no doubt we will eventually go into some sort of joint venture. We aren't going to get as much as we do now by exporting to Mexico, but 49 percent of something is a whole lot better than nothing."

For minicomputers, the government will allow U.S. firms to set up wholly-owned subsidiaries.

Currently, there are some 35 U.S. firms in Mexico ranging from giants as International Business Machines and Burroughs Corporation to smaller outfits such as Microdata Corporation and Durango Systems Inc.

Smaller companies contend the move helps the few big companies that can afford the estimated \$10 million to \$20 million investment needed to comply with the government's plan. Its action may do that, the government admitted,

but the existing market is so fragmented, no one wants to invest in it.

The *Journal* quoted an official of a Mexico City computer service company as saying of the move: "The program offers U.S. companies a unique opportunity to learn how to deal with the nationalistic attitudes they will be seeing a lot more of in the future. If they don't learn to play by local rules, they will have to settle for their own domestic markets."

Kepler and Ohm in a black box

A program to rethink the theorems of early scientists has been developed at Carnegie-Mellon University in Pittsburgh, PA.

According to a report in *Computerworld*, Patrick Langley developed the program as part of a doctoral thesis. Running on a Digital Equipment Corporation Decsystem-10, the program has been able to rediscover a series of principles set down by scientists such as Johannes Kepler and George Simon Ohm.

The program is fed the same raw data the early scientists worked with and has been able to reach the same conclusions—only faster. It takes the computer minutes to do what the scientists took months to do.

Currently, Langley's program has only been used to evaluate principles already known; however, the program could also be utilized by scientists engaged in current research projects.

An addition to the three R's

A "C" should be added to the three R's, according to David Moursand, professor of computer and information science at the University of Oregon in Eugene. That's C for computer literacy—the functional knowledge of computers children will need to compete for future jobs.

By 1985 a high percentage of all jobs will involve the use of computers in some way, placing those who don't know how to use them at definite disadvantage (see *80 Micro*, February 1982). But the educational system has not kept up with this trend, Moursand maintained.

The problem, he said, is that not enough teachers are computer literate themselves, and there are not enough computer-related instructional materials.

In an effort to overcome this problem, Moursand has committed himself for the last 15 years to teaching teachers how to bring computers into their classrooms. He organizes special seminars at the university to introduce teachers to computers and explain how the machines will change the way they teach. He also formed the International Council for Computers in Education and edits its journal, *The Computing Teacher*.

The ability to use computers could become as important as the ability to read and write when looking at future employment, Moursand said. Business and industry leaders have already proven that productivity increases dramatically with the use of computers.

"There is a revolution going on in industry. And we need to prepare our young people for it," he said.

Moursand contends it's time for the full-scale use of computers in the classroom. "Children should begin to learn how to use computers when they begin to learn any other subject," he said. "And with the resources that most schools have already, children could start to learn how to use computers in junior high school now," he added.

"The evolution we are about to see in education is indeed scary to many adults," he said, "but to children who grow up using computers, there is no fear."

"Our educational system is completely dependent, in essence, on how teachers and parents view the world. If teachers won't adjust to using computers, to this change in the world, it's going to be very, very hard for the kids to adjust to it," he noted.

What's happening in Woodlands?

Walking down the halls of Woodlands High School in Hartsdale, NY, you can see microcomputers wheeled into classrooms and hear students exclaim, "Fantastic, we're going to use the microcomputer in this class, too! I love it!"

What is happening at Woodlands? The answer is interdisciplinary use of the microcomputer.

Teachers are finding computers enhancing their curriculum. Micros can be used for drill, reinforcement and enrichment. Teachers are designing programs when commercial software is unavailable to meet their needs.

continued

CHARTS

A MUST FOR THE SERIOUS INVESTOR

Uses 48K, 2-Drive TRS-80 Model I or III*

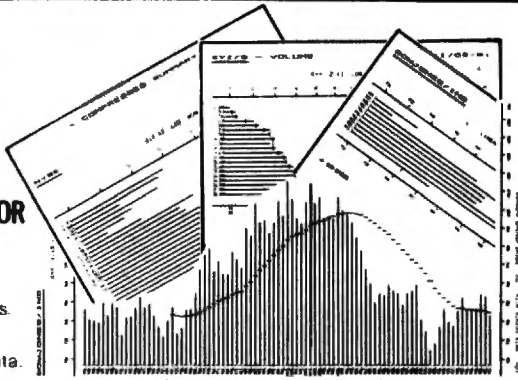

- \$ Use either logarithmic or linear plots.
- \$ User-selected moving averages.
- \$ Plot and store price and volume data.
- \$ Easy to use. No programming knowledge or complicated commands required. Friendly menus and prompts make operation simple. Easy file setup and maintenance, simple adjustments for stock splits, and automatic scale setup makes system operation a breeze for the most inexperienced user.
- \$ Error trapping lets you get away with common user goofs.
- \$ Up to 14 different presentation formats available for accurate graphic printouts.
- \$ Up to 6 years of data per stock can be recorded on a daily basis; 30 years on a weekly basis.

*Uses block graphics; inquire about other equipment types.

IMPROVE YOUR MARKET INVESTMENT DECISIONS BY ORDERING THIS POWERFUL ANALYTICAL TOOL TODAY

SEND COUPON TO: CP/\$ P.O. BOX 477 PLANO, TX 75074

- Send me CHART\$ today (\$79.95 enclosed - Texas residents add 5%)
- Send me additional information about CHART\$

Specify Equipment

- TRS-80 Model I
- TRS-80 Model III
- Epson MX80
- Line Printer V or VI

Name _____
 Address _____
 City _____ State _____ Zip _____

MP-X

Text Entry/Edit and Photocomposition

For TRS-80 Model-I or III with 48K RAM and 2 Disk Drives. (3 Disk for Model-I) "Native code" driver (parallel and RS-232) for Autologic APS-5* & Micro-5 Phototypesetters. Full screen editing and 100,000 compatible markup codes, allowing 200 User Defined, disk resident, Formats. Algorithmic Hyphenation with 500 word expandable exception dictionary and maintenance program assures correct word breaks. Optional line printer proofing for context, line-breaks, and hyphenation

This low cost, high quality system is now available for immediate delivery in a predefined configuration of 8 Font Families, for Service Center Use. A complete Telecommunication and Mail Order APS-5* Typesetting Service, for your MP-X job, is now offered by Watson Directory Corp. in St. Louis MO, with rates as low as \$4.95/ft. and measures up to 70 pica. Software & User Documentation... \$495. (User Documentation Only)..... \$ 25. Complete Hw/Sw TRS-80 Model III 48K System with User Documentation \$2895. Quotes on Custom Turn-Key System for "your" APS-5* available on request.

MICRO PRINT-X INC

P.O. BOX 581 Ballinger, Texas 76821 (915) 365-2343

*Trademark Radio Shack Div Tandy Corp. *Product of Autologic Inc

SOFTWARE YOU CAN BET ON!



POOL 80

Here's the program that will automate your office pool for professional football. POOL80 will:

- Keep track of the schedule
- Print weekly entry forms
- Print selection summary for players game time use
- Tabulate results
- Maintain cumulative records

POOL80 requires only a few minutes each week for updating. Comes ready to go for the 1982 season. Can be used year after year. Diskette only

Only \$20.00



DRAWS

This is the poker playing program that's getting the rave reviews. After a while each of the simulated players takes on its own individual personality - it's most uncanny. DRAWS has definitely sharpened my playing skills. (Lloyd Martin 80 Microcomputing Jan 1982) If you like playing poker, buy this program. It will be a long time before a better one comes along. (Richard Clode, Computer Shopper, Jan 1982)

Five card draw. Gardena CA rules. It's you against six almost human opponents.

Only \$15.00



SPREAD 80

The tops in professional football handicapping programs. This is another winner from Real World Simulations. The designers of DRAWS, SPREAD80 showed an average weekly profit of \$18 per \$100 bet for the 1978-1979, 1980 and 1981 seasons. If you bet football (and who doesn't) at the casino, with a bookie or in the office pool, this is the program for you. SPREAD80 comes on diskette ready for the 1982 season.

Only \$25.00

DRAWS supported on 500 baud cassette. Add \$4.00 for TRS-80 Model I or III diskette. All programs available on 8" disk for Model III at \$6.00 additional. PA residents add 6% sales tax. North Star diskette versions of DRAWS and SPREAD80 can be obtained from Real World Simulations, Box 4107, Torrance, CA 90510

WILSON Software Division
 539 Springhouse Lane • Camp Hill, PA 17011

TRS 80 is a Tandy Corporation trademark

CASM Z80* EDITOR/ASSEMBLER

TRS-80* Model I or Model III

- SOURCE FILES CREATED AND EDITED IN RAM
- SOURCE FILES ASSEMBLED FROM DISK
- CHAINING OF SOURCE FILES PERMITTED
- MACHINE LANGUAGE OBJECT CODE STORED IN RAM OR TO DISK

*TRS 80 is a trademark of Tandy Corp
 Z80 is a trademark of Zilog Corp

POWERFUL DISK ASSEMBLER

MINIMUM REQUIREMENTS:
 32K OF RAM
 ONE DISK DRIVE

COMPREHENSIVE INSTRUCTION MANUAL
 CASM W/MANUAL \$49
 CASM MANUAL ONLY \$20



P.O. Box 892 • Marysville, WA 98270 • (206) 659-4279 DEALER INQUIRIES INVITED

MOD III SOFTWARE

Finally the same software for MOD III as the CPM boys. We have taken the same packages and converted to MOD III.

1. GENERAL LEDGER

- Chart of Accounts
- Trial Balance
- Income Statement
- Dept Income Statement
- Links to other Peachtree* Modules

2. ACCOUNTS RECEIVABLE

- Open Item
- Aged A/R report
- 9 GL codes
- Customer status report
- Invoicing Statements

3. ACCOUNTS PAYABLES

- Vendor file
- Enter vouchers
- Print checks, check register
- Open voucher report
- Ageing Report
- Cash requirement
- Posts to GL

US \$250. per Module.

Creative Software

4450-B GREIG AVENUE
 TERRACE, B.C.
 CANADA V8G 1M3
 604-635-6117

Send for our full line catalogue

PULSE TRAIN *continued*

Students in English are studying spelling, grammar and reading comprehension on the TRS-80; students in Spanish and French are learning vocabulary and verb tenses; students in social studies are learning about the Middle East; students in sciences are learning about the metric system. Programs are also being written for Latin, reading competency, biology, algebra and many other courses.

Most of these programs are written by students for students.

Students are also taught Basic programming at the school. That course is open to all students and is taught at three levels — beginning, intermediate and advanced.

Woodlands High School has five TRS-80 Model IIIs with disk drives and 15 16K Model IIIs linked in a classroom network.

The programs are individualized and students are able to drill and review in their weak areas and accelerate in their strong areas. In past years, students in the resource math classes showed an average gain of two grade levels in one year.

The microcomputer program is supported by local funds and a grant from a regional group. It has been observed by teachers and administrators from Ardsley, Eastchester, Tarrytown and many other school districts in both Westchester and Rockland counties.

IBM returns to computer services

International Business Machines Corporation has taken the first step toward reentering the computer services business it abandoned years ago. The firm has announced the IBM Information Network, a remote information processing service.

Known internally for some time as the Tampa project, it is IBM's coast-to-coast computer and telephone network that will use more than 100 IBM program products ranging from text-editing to financial planning and analysis. The network is headquartered in Tampa, FL, where it was developed.

By using an IBM terminal and eventually an IBM table-top personal computer, large computer users will be able



At Woodlands high school, the TRS-80 is used to drill, enhance and reinforce students' skills.

to supplement their data processing requirements with specialized services. They will pay a fee to access by telephone IBM's computers and software programs.

The network will be available initially in Atlanta, Chicago, Dallas, New York, San Francisco, Washington, DC, and Tampa.

Some experts have predicted computer services will eventually dominate the data-processing market in dollar volume (*80 Micro News*, February 1982).

In Akron schools the name for micros is Firestone

For students and teachers in the Akron public schools, Firestone means more than where the rubber meets the road. Through a grant from that concern, the school system has been able to open its first microcomputer center.

The center has 10 stations each with an Apple II, disk drive, NEC color monitor and Epson MX-80 printer — equipment valued at \$38,420.

The facility is designed as a staff training laboratory, but will also be used to train students. Training programs offered range from introduction to microcomputers to skills applications. According to a statement released by the school system, the center will make it possible for hundreds of teachers and other staff members to become familiar with computers.

Computer store for the stars

Long-time Beverly Hills resident Murray Goralnick, who claims to be a pioneer in the development of simplified computer usage concepts, has opened a computer store in his home town.

The store retails a combination of computers and software set up to meet the needs of each individual customer. It specializes in integrating small computer systems into the non-computer environment.

"We're focused on removing the trauma often associated with this transition," Goralnick said in a statement.

He added he started the store in response to the "tremendous interest in personal computers expressed by Beverly Hills people."

The business will be conducted on an appointment-only basis, he noted.

Legislation and futurists featured on CompuServe

CompuServe has announced two new information services on its videotext system. "Federal Reports" offers subscribers articles and reports on legislation and its impact on the nation. It emphasizes activities affecting the financial and business climate in the United

continued

PULSE TRAIN^{continued}

States. "Future File" offers articles and interviews about the impact of today's decisions and technology on tomorrow's society.

HP hard disk to have MSC controller

Hewlett-Packard has signed a contract with Microcomputer Systems Corporation of Sunnyvale, CA, to buy controllers for HP's 5.25-inch Winchester disk drives. Deliveries of the controllers began last December.

The California firm, in a statement, said it sold the controllers at a price less than it would have cost HP to manufacture the device itself.

"Although HP could have designed its own controller, there was no need for them to expend the development time and dollars that would entail when MSC offered an immediate, field-proven, cost effective solution," said MSC Chairman and Chief Executive Officer James S. Toreson.

The MSC controller features 22-bit error detection, 11-bit error correction, automatic seek verify, automatic fault detection, multiple sector transfers, a full sector buffer, selectable sector size, programmable sector interleave, user-configurable drive parameters and low parts count.

Both firms declined to give details on the duration of the contract.

Slow acceptance of tube shopping

Growth of computer shopping will be sluggish during this decade, according to a Cambridge, MA, consulting firm.

The Yankee Group identified five barriers preventing home terminal shopping from becoming popular:

- Home terminals today fail to provide consumers detailed sensory information on products;
- Consumers shy away from buying expensive, offbeat items "sight unseen;"
- Service after sale is lacking;
- Delivery of items takes too long; and
- Consumers have no opportunity for social contact and recreation in shopping from home.

The next wave of home shopping systems will break by 1989, the consulting



Jonathon Rotenberg (left), president of the Boston Computer Society, accepted a \$10,000 donation from Nigel Searle, U.S. director of Sinclair Research Ltd.

firm said, largely wiping away growth barriers and launching a new era of merchandising. But the new systems must overcome the technical limitations of existing video-based systems, tie-in with entertainment programming and be supported by credible post sale service.

The Source on cable tv

Some 1.2 million cable-tv viewers will be receiving information services offered by Source Telecomputing Corporation of McLean, VA.

Called Sourcecable, the services are part of the cable-tv packages of four firms—Cox Cable Communications, Cross Country Cable, Storer Cable Communications and United Cable Television.

Sourcecable will offer regularly updated general, sports and business news; educational exercises; home shopping; a library of home and consumer information including health, emergency, energy, gardening, food and home maintenance data; and electronic games.

It is available in one-way and two-way modes. In the two-way version, viewers choose the service they want by pressing the appropriate buttons on a hand-held television controller.

The four cable firms also have included Sourcecable in their proposals for franchises in communities representing another 1.6 million viewers.

Gadget from Mattel to control swell

A \$50 diet computer has been released by Mattel Electronics. Called "Diet Trac," the hand-held device contains calorie and nutrition tables published by the American Diabetes Association and height-weight tables used by insurance companies to screen the obese.

To use Diet Trac, a dieter punches in his height and weight. The computer flashes back how much weight should come off and how many calories a day the dieter can consume to take it off. On the device's calculator-type keyboard are buttons for six major food categories permitting the dieter to find out how much meat, milk, bread, fruit or vegetables he or she is allowed.

It also provides a diet plan with alternative menus based on the "food exchange system" used by many nutritionists and weight control groups. For example, an exchange may let a dieter eat more meat if less bread is eaten. People on special diets can program those into the computer and also get a meal plan.

Dieters are required to punch in a report on everything they eat during the day. When Diet Trac learns too much of a food group has been consumed, it flashes a warning light and a running score of the calories consumed during the day. ■

80 LIST OF ADVERTISERS

RS Number	Page	RS Number	Page	RS Number	Page	RS Number	Page
36 A M Electronics	65	388 Creative Software	351	32 LNW Research	337	245 Programmer's Institute	160
553 ABS Suppliers	414	596 Creative Thaumaturgy	418	33 LNW Research	212	80 Program Store, The	276, 279
173 ABS Suppliers	401	337 Crown Microproducts	351	44 LT Data	223	143 Progressive Electronics	158
107 Aardvark 80	373	Cybernetics Inc.	244	53 Laredo Systems Inc.	267	91 Prosoft	55, 312
26 Access Unlimited	198, 187	563 D.B. Software Company	405	191 Lawyers Microcomputing, The	190	565 Protean Scientific	414
197 Ace Computer Products	40	517 DCS Software	198	155 LEDS Publishing Company Inc.	310	48 Quality Computer Services	221
79 Acorn Software	78, 79	400 D.L. Dawson	396	358 Lamona Tech. Services	358, 383	194 Quant Systems	120
280 Advanced Operating Systems	117	DSC Publishing	297	Level IV Products Inc.	151	366 RABCO Enterprises	335
19 Adventure International	108, 109	511 Dan G. Haney & Associates Inc.	381	131 Libra Labs	304	41 Racet Computer	249
20 Adventure International	273	15 Data Resources	409	135 Lindbergh Systems	374	140 Radio Ranch Inc.	331
585 Adventure International	418	292 Data-RX Inc.	365	Load 80	227	264 Rainbow P&P Company	84
82 Aercomp Inc.	290, 291	118 Data Services Inc.	231	Load 80 Back Issues	359	265 Rainbow P&P Company	120
75 Alcor Systems	209	108 Data Trans.	222	115 Lynn Computer Service	229	296 Rainbow, The	115
136 Algorix	217	584 David Modney	412	304 MECA	359	130 Rand's Inc.	375
178 All Systems Go	395	394 Decision Science Software Inc.	294	393 MEGC	147	Really Software Company	301
11 Alpha Byte Stores, Inc.	C11, 16, 17	590 Demison Manufacturing Company	416	196 Maine Software	289	597 Really Software Company	404
574 Alpha Data Inc.	418	57 Design Solutions Inc.	214, 215	241 Mark Data Products	319	114 Retware	331
11 Alpha Products Company	20, 21, 23	269 Digital Systems Engineering	303	332 Martin Consulting	335	145 REMarkable Software	71
112 Alphanetics	71	101 Discount Software Group	46	148 Master Electronics	377	129 Remsoft Inc.	385
113 Alphanetics	71	62 Displugged Video	60, 61	83 Med Systems Software	45, 63, 77	343 Rogo Computer Products	394
69 Alternata Source, The	298	357 Don Electronics	353	250 Melbourn House	95	55 SID	110
217 American Business Computers	125	Dow Jones Information Service	97	550 Manio Systems	118	286 STSC Inc.	87
218 American Business Computers	127	353 Dresselhaus Computer Products	188	188 Mercer Systems Inc.	147	142 Sales Data Inc.	123
219 American Business Computers	127	268 Dubois & McNamara	136	13 Meta Technologies Corporation	9, 11, 13	203 Scientific Engineering Lab.	375
220 American Business Computers	129	177 E-Z Software	141	149 Micro Architect	40	510 Scott Tasso	375
221 American Business Computers	129	216 E.A.P. Company	301	568 Micro Architect	406	372 Semi Disks Systems	122
222 American Business Computers	129	271 EBG & Associates	158	245 Micro-Computer Sales Corp.	375	16 Shannon Magnetics	83, 255
223 American Business Computers	131	Edu Ware	349	247 Microcomputer Technology Inc.	69	569 Shirley Software	406
224 American Business Computers	133	49 ESI Lynx	155	248 Microcomputer Technology Inc.	391	594 Simplified Software Systems	418
284 Ancie Labs	348	154 Eigen Systems	308	76 Micro Design	367	12 Simutek	167, 169, 171
40 Apparel Inc.	250, 251	Eighty-Microcomputing	313, 363, 365, 393, 395	77 Micro Design	367	213 66 Micro Journal	401
512 Apparel Inc.	285	Eighty-Microcomputing Book Department	355, 356, 357	78 Micro-Design	367	Snappware	157, 158, 161, 163, 165
6 APCsoft Publishing	112	Eighty-Microcomputing Book Shelf	397, 398	598 Micro Distributors	405	84 Soft Sector Marketing Inc.	33, 111, 261
395 Aris Logic Systems Inc.	363	329 Eighty Northwest Journal	121	132 Micro-80	237	85 Soft Sector Marketing Inc.	269
571 Aspen Ribbons Inc.	414	159 Electronic Specialists Inc.	397	161 Micro-Grip Ltd.	315	86 Soft Sector Marketing Inc.	271
65 Aspen Software Company	47	564 Electronic Specialists Inc.	418	111 Micro Images	310	87 Soft Sector Marketing Inc.	263
528 Atlantic Cabinet Corp.	161	93 Epton American	138, 139	50 Micro Investment Software	365	88 Soft Sector Marketing Inc.	265, 267
Atlantic Ham Festival	213	97 Exatron	138, 139	209 Micro Learningware	301	398 Softbyte Computing	363
287 Aute! Electronic Company	359	93 Exatron	138, 139	50 Micro Mainframe	413	379 Software Company, The	280
28 Automated Simulations	93	94 Exatron	257	96 Micro Management Systems	277	374 Soltek Software	220
371 B Erickson	334	Excetionix	330	Micro-Media	173	402 Software Banc	162
300 B T Enterprises	119	382 FIS Associates Inc.	298	182 Micro Mega	330	43 Software Concepts	28, 29
152 BCompage	76	36 Fantastic Software	341	117 Micro Mint	288	365 Software Galore	363
552 B W J Technology Inc.	412	267 Flippy Disk Services	175	270 Micro Moonlighter Newsletter	331	309 Softwarehouse International	154
Back Issue Prices	375	Foreign Subscription Letter	387	363 Micro Print X Inc.	351	310 Softwarehouse International	401
378 Barker Computer	288	214 Fort Worth Computer	154	405 Micropro Systems	327	327 Software Support	177
289 Basics & Beyond	390	14 Free Coupons	15	Microprogrammer's The	262	198 Source Lab Systems	39
Bayesian Investment Services	170	240 Freedom Tech International Inc.	225	387 Micro R&D	312	119 Spectral Associates	72
243 Bay Technical Associates	223	531 Frog Prince Software	362	312 Microsette	146	557 Spectral Associates	404
134 Beard Software Development Company	132	66 Futuresoft	153	282 Microsoft CPD	299	100 Speedway Electronics	323
28 Big Five Software Company	89	Futureview Inc.	91	362 Micro Solutions Inc.	349	205 Starbuck Data Company	401
Binders	299	251 Galactic Software	101	384 Micro Systems Software Inc.	C11, 275	396 Starware	363
294 Bosen Electronics	299	186 Good-Lyddon Systems	385	390 Micro Tech Exports Inc.	363	8 Stacking Source, The	181
302 Bottom Line The	70	Gosub Software	391	125 Micro Works	391	386 Street Electronics	295
308 Bottom Line The	301	H&H Electronics	43	148 Midwest Data Systems	43	180 Sturdivant & Dunn	385
181 CMD Micro	170	9 H&E Computerics Inc.	193-205	72 Wines Electronics Corp.	239	71 Sublogic	345
311 CPS	351	166 H&H Trading Company	314	137 Miller Computer Services	100	231 Sublogic	41
100 CPU Shop, The	245	567 H&H Trading Company	316	98 Mini Micro Mart Inc.	305	Subscription Letter	191
138 C&S Electronics Marj	358	244 H&H Inc.	421	123 Misosys	254	573 Success Analysis Corp.	412
397 Cedar Software Company	363	370 HANCO Software	335	566 Modular Microsystems Inc.	408	285 Sun Research	230
595 Cer Comp	416	572 Hayden Book Company	412	67 Mumford Micro Systems	49	391 Swayback Software	392
570 Class I Systems	412	47 Heath/Zentith Company	99	128 Nelson Software Systems	82	134 Synergistic Solar Inc.	377
225 Cleveland Electronics	133	46 Hexagon Systems	297	255 New Classic Software	135	10 Syntax Beta	328
102 Cloud Magazine Inc.	383	508 Hikari Group	358	232 Nocona Electronics	192	174 Syracuse R&D Center	401
103 Cloud Magazine Inc.	363	262 Hogg Labs Inc.	236	50 Omikron	31	583 Tab Books	408
121 Cognitec	145	395 Holman D P Services	353	583 Omikron	408	189 Tab Sales	173
Color Software	240	153 Holmes Engineering	364	195 Omitek	178, 327	70 Taranto & Associates	137
361 Communication Systems Lab	349	175 Howe Software	178	206 Options-80	401	335 Tatum Labs	84
210 Complete Computer Services	301	560 Hugh Roberts	408	599 Optonica Technology	408	263 Tatum Labs	210
276 CompuLink Corp	8	588 Hurricane Laboratories	405	275 Orange Micro Inc.	102, 103	59 Texas Computer Systems	415
235 CompuServe	385	IJG Computer Services	143, 282	151 Onon Instruments	126	Text Edit	395
385 CompuSoft Publishing	387	274 Illustrated Memory Banks	377	25 PC Newsletter	319	144 Thomas V. Lenz	311
382 Computer Accessories of Arizona	334	126 Insiders Software Consultants	258	242 P M G	319, 402, 403	527 Tiny-C	325
120 Computer Applications Unlimited	51	591 Instant Software Inc.	408	352 P M W	383	81 Total Access	149
139 Computer Case Company	223	582 Instant Software Inc.	406	383 P Tree Inc.	301	599 Transtek	406
133 Computer Discount of America	175	351 Institute For Scientific Analysis Corp.	362, 383	207 Pacific Exchanges	154, 301, 382, 375	37 Traxx	7
291 Computer House	399	182 Interface Inc.	379	122 Pan American Electronics	243	TRI Star	270
18 Computer Plus	27	519 Intersoft Unlimited	379	333 Peggtronics	270	522 TwoSixteen Magazine	379
108 Computer Shack	52, 53	273 J.F. Consulting	397	558 Peggtronics	405	University Microfilms	387
39 Computer Shopper	347	570 J.F. Consulting	414	Percom Data Company	3	564 V. Bertrand	416
325 Computer Software Design Inc.	179	202 JES Graphics	401	1 Percom Data Company	25	V.R. Data	410, 411
568 Computer Software Design Inc.	412	Jesse Jones Box	387	2 Percom Data Company	25	169 Van Horn Office Supply	314
369 Computerware	325	42 JPC Products	247	3 Percom Data Company	24	390 Voicetech Inc.	59
27 CompuTel	182	183 Jmscol Inc.	307	124 Pery Oil & Gas	274	147 Walonick Associates	313
365 Comsoft	387	256 Joe Computer	236	Phase I Systems	211	Wayne Green Books	35, 395, 417
104 Comsoft	259	150 Johnson Associates	308	290 Pickles & Trout	398	586 Wayne Green Books	418
68 Contract Services Associates	232, 233	581 John Wiley & Sons	408	180 Pioneer Software	296	179 Western Operations	236
105 Coobol, Inc.	378	354 K&K Computer Peripherals	386	561 Pioneer Software	404	212 William A. Fink	401
308 Corsair Group, The	158	562 K&K Computer Peripherals	404	377 Plug Bug, The	189	192 Wilson Software	351
45 Conucopia Software	389	331 KSoft	223	73 Plus Computer Technology Inc.	371	381 Wizard Electronics Inc.	301
200 Corsair Computer	375	Kengora Corporation	85	61 Powersoft	81, 228	356 Workbench Software	386
376 Cosmopolitan Electronic Corp.	361	359 Kwik Software	386	63 Precision Prototypes	407	578 World Computer Resource	148
187 Cottage Software	294	30 LNW Research	113	253 Pro 80 Systems	309	589 XPS Inc.	405
190 Creative Computer Center	311	31 LNW Research	87	288 Process Control Technics	377	156 XYZT Computer Dimensions Inc.	395
						York 10 Computerware	311

For further information from our advertisers, please use the Reader Service card.

READER SERVICE

Please help us to bring you a better magazine—by answering these questions.

This card is valid until June 30, 1982

A. What is your annual income?

- 1 Under \$20,000
- 2 \$21,000—\$30,000
- 3 \$31,000—\$40,000
- 4 \$41,000—\$50,000
- 5 Over \$50,000

B. If you read any of the following magazines, please rate their usefulness to you on a scale of 1 (least) to 5 (most).

- ___ 1 Microcomputing
- ___ 2 Desktop Computing
- ___ 3 Byte
- ___ 4 Popular Computing
- ___ 5 Creative Computing
- ___ 6 80 U S

C. Do you own a stringy floppy?

- 1 Yes
- 2 No, plan to buy one
- 3 No, don't plan to buy one

D. How much have you invested in hardware (including peripherals)?

- 1 Less than \$1,000
- 2 \$1,000—\$2,000
- 3 \$2,001—\$3,000
- 4 \$3,001—\$4,000
- 5 Over \$4,000

E. What is your level of education?

- 1 High School
- 2 Trade/Technical School
- 3 College
- 4 Graduate School

F. Do you have any influence over the use or purchase of computing equipment for your company?

- 1 Yes
- 2 No

G. Do you own either of the following?

- 1 PMC-80
- 2 LNW-80

H. What types of programs published in 80 Microcomputing do you actually type into your computer? Check the 2 categories of most interest.

- 1 Business
- 2 Games
- 3 Utilities
- 4 Education
- 5 Graphics
- 6 Hobby
- 7 Home Finance/Management

I. Do you have any influence over the purchase of computer systems for an educational institution?

- 1 Yes
- 2 No
- 3 Doesn't apply

J. How much have you invested in software?

- 1 Less than \$100
- 2 \$100—\$250
- 3 \$251—\$500
- 4 \$501—\$1,000
- 5 Over \$1,000

L. On a scale of 0 (no interest) to 5 (great interest) please rate your interest in seeing the following types of products reviewed in 80 Microcomputing:

- ___ 1 Business
- ___ 2 Games
- ___ 3 Utilities
- ___ 4 Hardware
- ___ 5 Books
- ___ 6 Word Processing
- ___ 7 Science/Technical
- ___ 8 Home/Hobby
- ___ 9 Education

M. If you are not a subscriber, please circle number 500.

Reader Service: To receive more information from any of the advertisers in this issue of 80 Microcomputing, circle the number on the postage-paid Reader Service Card that corresponds with the Reader Service number on the ad in which you are interested. You will find numbers, preceded by a "•", near the logo of each advertiser. Complete the entire card, drop into a mailbox and in 4-6 weeks you will hear from the advertiser directly.

1	6	11	16	21	151	156	161	166	171	301	306	311	316	321	451	456	461	466	471
2	7	12	17	22	152	157	162	167	172	302	307	312	317	322	452	457	462	467	472
3	8	13	18	23	153	158	163	168	173	303	308	313	318	323	453	458	463	468	473
4	9	14	19	24	154	159	164	169	174	304	309	314	319	324	454	459	464	469	474
5	10	15	20	25	155	160	165	170	175	305	310	315	320	325	455	460	465	470	475
26	31	36	41	46	176	181	186	191	196	326	331	336	341	346	476	481	486	491	496
27	32	37	42	47	177	182	187	192	197	327	332	337	342	347	477	482	487	492	497
28	33	38	43	48	178	183	188	193	198	328	333	338	343	348	478	483	488	493	498
29	34	39	44	49	179	184	189	194	199	329	334	339	344	349	479	484	489	494	499
30	35	40	45	50	180	185	190	195	200	330	335	340	345	350	480	485	490	495	500
51	56	61	66	71	201	206	211	216	221	351	356	361	366	371	501	506	511	516	521
52	57	62	67	72	202	207	212	217	222	352	357	362	367	372	502	507	512	517	522
53	58	63	68	73	203	208	213	218	223	353	358	363	368	373	503	508	513	518	523
54	59	64	69	74	204	209	214	219	224	354	359	364	369	374	504	509	514	519	524
55	60	65	70	75	205	210	215	220	225	355	360	365	370	375	505	510	515	520	525
76	81	86	91	96	226	231	236	241	246	376	381	386	391	396	526	531	536	541	546
77	82	87	92	97	227	232	237	242	247	377	382	387	392	397	527	532	537	542	547
78	83	88	93	98	228	233	238	243	248	378	383	388	393	398	528	533	538	543	548
79	84	89	94	99	229	234	239	244	249	379	384	389	394	399	529	534	539	544	549
80	85	90	95	100	230	235	240	245	250	380	385	390	395	400	530	535	540	545	550
101	106	111	116	121	251	256	261	266	271	401	406	411	416	421	551	556	561	566	571
102	107	112	117	122	252	257	262	267	272	402	407	412	417	422	552	557	562	567	572
103	108	113	118	123	253	258	263	268	273	403	408	413	418	423	553	558	563	568	573
104	109	114	119	124	254	259	264	269	274	404	409	414	419	424	554	559	564	569	574
105	110	115	120	125	255	260	265	270	275	405	410	415	420	425	555	560	565	570	575
126	131	136	141	146	276	281	286	291	296	426	431	436	441	446	576	581	586	591	596
127	132	137	142	147	277	282	287	292	297	427	432	437	442	447	577	582	587	592	597
128	133	138	143	148	278	283	288	293	298	428	433	438	443	448	578	583	588	593	598
129	134	139	144	149	279	284	289	294	299	429	434	439	444	449	579	584	589	594	599
130	135	140	145	150	280	285	290	295	300	430	435	440	445	450	580	585	590	595	600

Name _____
 Address _____
 City _____ State _____ Zip _____

80 Microcomputing • May 1982

BOOKS

80 Microcomputing
Peterborough NH 03458

Please send me the following 80 Microcomputing products:

Qty.	Catalog #	Title	Unit Price	Total

Shipping and handling charges:
\$1.50 1st book, \$1.00 each additional book (UPS, use street address)
\$10.00 each book overseas airmail

Shipping/handling _____
Total _____

Enclosed \$ _____ Check M.O.

Bill: AE MC VISA

Card # _____

Exp date _____ Interbank # _____

Signature _____

Name _____

Address _____

City _____ State _____ Zip _____

Please allow 4-6 weeks for delivery

No C.O.D. orders accepted.

SUBSCRIPTION

80 microcomputing

subscribers save \$10
off the
newsstand price.

New subscription Renewal
 1 year—\$24.97

Enclosed \$ _____ Check M.O.
Bill: MC Visa AE me

Card # _____ Exp. date _____

Signature _____ Interbank # _____

Name _____

Address _____

City _____ State _____ Zip _____

Canada—\$27.97, 1 year only, US funds.
Foreign Surface—\$44.97 1 year only, US funds.
Foreign Air—Please inquire.

Place
Stamp
Here



Subscription Dept.
POB 981
Farmingdale NY 11737

Place
Stamp
Here



Att. Mail Order
Peterborough NH 03458



Place
Stamp
Here

80 microcomputing bookshelf

BASIC & PASCAL



new

new

ANNOTATED BASIC—A NEW TECHNIQUE FOR NEOPHYTES.—BASIC programming was supposed to be simple—a beginner's programming language which was so near to English that it could be easily understood. But, in recent years, BASIC has become much more powerful and therefore much more difficult to read and understand. BASIC simply isn't basic anymore. *Annotated BASIC* explains the complexities of modern BASIC. It includes complete TRS-80* Level II

BASIC programs that you can use. Each program is annotated to explain in step-by-step fashion the workings of the program. Programs are flowcharted to assist you in following the operational sequence. And—each chapter includes a description of the new concepts which have been introduced. *Annotated BASIC* deals with the hows and whys of TRS-80 BASIC programming. *How* is a program put together? *Why* is it written that way? By observing the programs and following the annotation, you can develop new techniques to use in your own programs—or modify commercial programs for your specific use. *Annotated BASIC Volume 1* BK7384 \$10.95. *Annotated BASIC Volume 2* BK7385 \$10.95. Order Both Volumes and Save! BK738402 \$18.95

THEORY Z—How American Business Can Meet the Japanese Challenge—by William Ouchi. Why are the Japanese catching up and surpassing American industrial productivity? What allows Japanese industrialists to offer guaranteed lifetime employment to their workforce? This book will help you understand the Theory Z managerial philosophy and its implications for the American corporate future. Examples are given of the American industrial giants already operating under Z-style management, and the impact of this style on the quality of their executives and workers is explored. A must for the alert businessman, large or small. BK1226 \$12.95*

SO YOU ARE THINKING ABOUT A SMALL BUSINESS COMPUTER—by Richard G. Canning and Nancy C. Leeper. For a well-organized manual on the process of selecting the right computer system for your small business, this text can't be excelled. Designed to introduce the novice in data and word processing to the real benefits of computerization, the book is filled with money- and time-saving tips, photos of equipment, lists of suppliers, prices, explanations of computer terminology, and helpful references to additional sources of information. Everyone contemplating a first computer installation should have this book. BK1222 \$14.00*

PAYROLL WITH COST ACCOUNTING—IN BASIC—by L. Poole & M. Borchers, includes program listings with remarks, descriptions, discussions of the principle behind each program, file layouts, and a complete user's manual with step-by-step instructions, flowcharts, and simple reports and CRT displays. Payroll and cost accounting features include separate payrolls for up to 10 companies, time-tested interactive data entry, easy correction of data entry errors, job costing (labor of distribution), check printing with full deduction and pay detail, and 16 different printed reports, including W-2 and 941 (in CBASIC). BK1001 \$20.00.*

SOME COMMON BASIC PROGRAMS—Published by Adam Osborne & Associates, Inc. Perfect for non-technical computerists requiring ready-to-use programs. Business programs, plus miscellaneous programs. Invaluable for the user who is not an experienced programmer. All will operate in the stand-alone mode. BK1053 \$14.99 paperback.

PIMS: PERSONAL INFORMATION MANAGEMENT SYSTEM—Learn how to unleash the power of a personal computer for your own benefit in this ready-to-use data-base management program. BK1009 \$11.95.*

INTRODUCTION TO TRS-80 LEVEL II BASIC AND COMPUTER PROGRAMMING—by Michael P. Zabinski. Written by an experienced educator, this is the book for those beginners who want to learn about computers without having to become an expert. It has practical programs, useful line-by-line comments, excellent flowcharts accompanied by line numbers and over 200 exercises which help the reader assess progress, reinforce comprehension, and provide valuable practical experience. BK1219 \$10.95.*

50 BASIC EXERCISES—by J. P. Lamoitier. This book is structured around the idea that the best way to learn a language is through actual practice. It contains 50 completely explained exercises: statement and analysis of the problem, flowcharts, programs and actual runs. Program subjects include mathematics, business, games, and operations research, and are presented in varying levels of difficulty. This format enables anyone to learn BASIC rapidly, checking their progress at each step. BK1192 \$12.95*

THE BASIC HANDBOOK—SECOND EDITION—by David Lien. This book is unique. It is a virtual ENCYCLOPEDIA of BASIC. While not favoring one computer over another, it explains over 250 BASIC words, how to use them and alternate strategies. If a computer does not possess the capabilities of a needed or specified word, there are often ways to accomplish the same function by using another word or combination of words. That's where the HANDBOOK comes in. It helps you get the most from your computer, be it a "bottom-of-the-line" micro or an oversized monster. BK1174 \$19.95.*

LEARNING LEVEL II—by David Lien. Written especially for the TRS-80, this book concentrates on Level II BASIC. It explores every important BASIC language capability. Updates are included for those who have studied the Level I User's Manual. Sections include: how to use the Editor, dual cassette operation, printers and peripheral devices, and the conversion of Level I programs to Level II. BK1175 \$15.95.*

BASIC BASIC (2ND EDITION)—by James S. Coan. This is a textbook which incorporates the learning of computer programming using the BASIC language with the teaching of mathematics. Over 100 sample programs illustrate the techniques of the BASIC language and every section is followed by practical problems. This second edition covers character string handling and the use of data files. BK1026 \$10.50.*

ADVANCED BASIC—Applications including strings and files, coordinate geometry, area, sequences and series, simulation and graphing and games. BK1006 \$10.75.*

INTRODUCTION TO PASCAL—by Rodney Zaks. A step-by-step introduction for anyone wanting to learn the language quickly and completely. Each concept is explained simply and in a logical order. All features of the language are presented in a clear, easy-to-understand format with exercises to test the reader at the end of each chapter. It describes both standard PASCAL and UCSD PASCAL—the most widely used dialect for small computers. No computer or programming experience is necessary. BK1189 \$14.95.*

PROGRAMMING IN PASCAL—by Peter Grogono. The computer programming language PASCAL was the first language to embody in a coherent way the concepts of structured programming, which has been defined by Edsger Dijkstra and C.A.R. Hoare. As such, it is a landmark in the development of programming languages. PASCAL was developed by Niklaus Wirth in Zurich; it is derived from the language ALGOL 60 but is more powerful and easier to use. PASCAL is now widely accepted as a useful language that can be efficiently implemented, and as an excellent teaching tool. It does not assume knowledge of any other programming language and therefore suitable for an introductory course. BK1140 \$12.95.*

—GAMES—

40 COMPUTER GAMES FROM KILOBAUD MICROCOMPUTING—Forty games in all in nine different categories. Games for large and small systems, and even a section on calculator games. Many versions of BASIC used and a wide variety of systems represented. A must for the serious computer gamesman. BK7381 \$7.95.*

BASIC COMPUTER GAMES—Okay, so once you get your computer and are running in BASIC, then what? Then you need some programs in BASIC, that's what. This book has 101 games for you from very simple to real buggers. You get the games, a description of the games, the listing to put in your computer and a sample run to show you how they work. Fun. Any one game will be worth more than the price of the book for the fun you and your family will have with it. BK1074 \$7.50.*

MORE BASIC COMPUTER GAMES—Edited by David H. Ahl. More fun in BASIC! 84 new games from the people who brought you *BASIC Computer Games*. Includes such favorites as Minotaur (battle the mythical beast) and Eliza (unload your troubles on the doctor at bargain rates). Complete with game description, listing and sample run. BK1182 \$7.50.*

WHAT TO DO AFTER YOU HIT RETURN—PCC's first book of computer games... 48 different computer games you can play in BASIC... programs, descriptions and many illustrations. Lunar Landing, Hamurabi, King, Cival 2, Qubic 5, Taxman, Star Trek, Crash, Market, etc. BK1071 \$16.50.*

—MONEYMAKING—

HOW TO MAKE MONEY WITH COMPUTERS—In 10 information-packed chapters, Jerry Felsen describes more than 30 computer-related, money-making, high profit, low capital investment opportunities. BK1003 \$15.00.*

HOW TO SELL ANYTHING TO ANYBODY—According to *The Guinness Book of World Records*, the author, Joe Girard, is "the world's greatest salesman." This book reveals how he made a fortune—and how you can, too. BK7306 \$2.25.*

THE INCREDIBLE SECRET MONEY MACHINE—by Don Lancaster. A different kind of "cookbook" from Don Lancaster. Want to slash taxes? Get free vacations? Win at investments? Make money from something that you like to do? You'll find this book essential to give you the key insider details of what is really involved in starting up your own money machine. BK1071 \$5.95.*

* No C.O.D. orders accepted. All orders add \$1.50 for the first book, \$1.00 each additional book, \$10.00 per book foreign airmail. Please allow 4-6 weeks for delivery. Questions regarding your order? Please write to Customer Service at the following address. Use the order card in this magazine or itemize your order on a separate piece of paper and mail to 80 Microcomputing Book Department • Peterborough NH 03458. Be sure to include check or detailed credit card information.

FOR TOLL FREE ORDERING CALL 1-800-258-5473

80 microcomputing bookshelf

MICROCOMPUTING CODING SHEETS *Microcomputing's* dozen or so programmers wouldn't try to work without these handy scratch pads, which help prevent the little errors that can cost hours and hours of programming time. Available for programming in Assembly/Machine Language (PD1001), which has columns for address, instruction (3 bytes), source code (label, op code, operand) and comments; and for BASIC (PD1002) which is 72 columns wide. 50 sheets to a pad \$2.39.*

Z-80 SOFTWARE GOURMET GUIDE AND COOKBOOK —by Nat Wadsworth. Scelbi's newest cookbook! This book contains a complete description of the powerful Z-80 instruction set and a wide variety of programming information. Use the author's ingredients including routines, subroutines and short programs, choose a time-tested recipe and start cooking! BK1045 \$16.99.*

Z-80 ASSEMBLY LANGUAGE PROGRAMMING —BK1177—by Lance A. Leventhal. This book thoroughly covers the Z-80 instruction set, abounding in simple programming examples which illustrate software development concepts and actual assembly language usage. Features include Z-80 I/O devices and interfacing methods, assembler conventions, and comparisons with 8080A/8085 instruction sets and interrupt structure. \$16.99.*

—Z-80—

TRS-80 ASSEMBLY LANGUAGE—by Hubert S. Howe, Jr. This book incorporates into a single volume all the pertinent facts and information you need to know to program and enjoy the TRS-80. Included are clear presentations of all introductory concepts, completely tested practical programs and subroutines, details of ROM and RAM and disk operating systems, plus comprehensive tables, charts and appendices. Suitable for the first time user or more experienced users. BK1217 \$9.95.*

PROGRAMMING THE Z-80—by Rodney Zaks. Here is assembly language programming for the Z-80 presented as a progressive, step-by-step course. This book is both an educational text and a self-contained reference book, useful to both the beginning and the experienced programmer who wish to learn about the Z-80. Exercises to test the reader are included. BK1122 \$15.95.*

INSIDE LEVEL II—For machine language programmers. This is a comprehensive reference guide to the Level II ROMs, allowing easy utilization of the sophisticated routines they contain. It concisely explains set-ups, calling sequences, variable passage and I/O routines. Part II presents an entirely new composite program structure which unloads under the SYSTEM command and executes in both BASIC and machine code with the speed and efficiency of a compiler. Special consideration is given to disk systems. BK1183 \$15.95.*



NANOS SYSTEM REFERENCE CARDS

For Models I, II, III and color computer

At last! No more flipping through the pages of the Basic manual! No more working through the maze of machine language instructions! These cards completely summarize the Basic and Assembler manuals! **FEATURES INCLUDE:**

memory map, eyeball graphics, math instructions, basic commands, store instructions, basic functions, load instructions, basic statements, move instructions, special keys, exchange instructions, print using examples, shift instructions, basic special characters,

compare instructions, basic and assembler messages and codes, branch instructions, basic facts, data alteration instructions, reserved words, I/O instructions, ROM routines, complete character chart with graphics and space-compression codes, hex-dec chart, control code cross-reference, assembler instructions commands and operators, screen line layout, editor commands & subcommands, condition code easy access

Designed as a fold-up, accordion-style card. Fits in your pocket. Panels organized for optimum speed for reference.

Model I: BASIC only FC1001	\$2.95
Model I: BASIC and Assembler FC1002	\$4.95
Model II: BASIC and Assembler FC1005	\$5.95
Model III: BASIC only FC1004	\$3.95
Model III: BASIC and Assembler FC1003	\$5.95
Color: BASIC and Extended FC1006	\$4.95

ALL NEW—FOR 80 OWNERS ENCYCLOPEDIA FOR THE TRS-80*

ENCYCLOPEDIA FOR THE TRS-80** is the newest peripheral for your microcomputer. This ten-volume reference series contains programs and articles especially selected to extend the documentation that comes with the TRS-80. Volumes of the **Encyclopedia** are being issued one-at-a-time, approximately six weeks apart. This means that each new volume will reflect the latest developments in TRS-80 microcomputing. **Encyclopedia for the TRS-80** is available in two editions. The deluxe **COLLECTOR'S EDITION** has a handsome green and black hard cover with a dust jacket. A soft cover edition is also available.

To order single hard cover volumes of the **Encyclopedia** please specify:

Volume 1	EN8101	\$19.95*
Volume 2	EN8102	\$19.95*
Volume 3	EN8103	\$19.95*
Volume 4	EN8104	\$19.95*
Volume 5	EN8105	\$19.95*
Volume 6	EN8106	\$19.95*
Volume 7	EN8107	\$19.95*

To order single softcover volumes of the **Encyclopedia** please specify:

Volume 1	EN8081	\$10.95*
Volume 2	EN8082	\$10.95*
Volume 3	EN8083	\$10.95*
Volume 4	EN8084	\$10.95*
Volume 5	EN8085	\$10.95*
Volume 6	EN8086	\$10.95*
Volume 7	EN8087	\$10.95*

*No C.O.D. orders accepted. All orders add \$1.50 for the first book, \$1.00 each additional book, \$10.00 per book foreign airmail. Please allow 4-6 weeks for delivery. Questions regarding your order? Please write to Customer Service at the following address.

ENCYCLOPEDIA FOR THE TRS-80*

A library of useful information for your TRS-80.

- Business
- Graphics
- Hardware
- Software
- Word Processing
- Networking
- Utility

VOLUME 4

SPECIAL INTRODUCTORY OFFER
Order the entire set (the first ten volumes) of the **Encyclopedia for the TRS-80** and receive the tenth volume **FREE!**

10 Volume deluxe hard cover **COLLECTOR'S EDITION** — a \$199.50 value.

EN8100 \$164.00 postpaid

10 Volume soft cover edition, a \$109.50 value.

EN8080 \$83.00 postpaid

ENCYCLOPEDIA LOADER is the software companion to the **Encyclopedia for the TRS-80**. This special series of cassettes will allow you to load selected programs from the **Encyclopedia** instantly. Hours of keyboarding time and the aggravating search for typos is eliminated by using the **Encyclopedia Loader**.

Encyclopedia Loader for Volume 1 of the **Encyclopedia for the TRS-80** is available at a **Special Introductory Price** of \$12.95 (a \$14.95 value). To take advantage of this offer specify:

EL800111 \$12.95*

Additional **Encyclopedia Loaders** will be available as each volume of the **Encyclopedia for the TRS-80** is issued. To order specify **Encyclopedia Loader**:

Volume 2	EL8002	\$14.95*
Volume 3	EL8003	\$14.95*
Volume 4	EL8004	\$14.95*
Volume 5	EL8005	\$14.95*
Volume 6	EL8006	\$14.95*
Volume 7	EL8007	\$14.95*

Use the order card in this magazine or itemize your order on a separate piece of paper and mail to 80 *Microcomputing* Book Department • Peterborough NH 03458. Be sure to include check or detailed credit card information.

FOR TOLL FREE ORDERING CALL 1-800-258-5473



● **UNDERSTANDING AND PROGRAMMING MICROCOMPUTERS**—BK7382—A valuable addition to your computing library. This two-part text includes the best articles that have appeared in 73 and KiloBaud Microcomputing magazines on the hardware and software aspects of microcomputing. Well-known authors and well-structured text helps the reader get involved. \$10.95*

● **SOME OF THE BEST FROM KILOBAUD MICROCOMPUTING**—BK7311—A collection of the best articles that have appeared in KiloBaud MICROCOMPUTING. Included is material on the TRS-80 and PET systems, CP/M, the 8080/8085/Z-80 chips, the ASR-33 terminal. Data base management, word processing, text editors and file structures are covered too. Programming techniques and hard-core hardware construction projects for modems, high speed cassette interfaces and TVTs are also included in this large format, 200 plus page edition \$10.95.*

MR. Pennington TRS-80 DISK & OTHER MYSTERIES

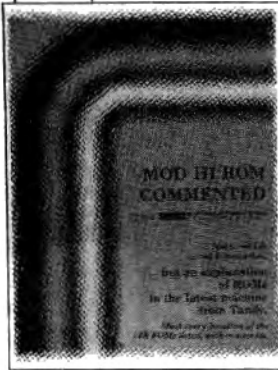

TRS-80 DISK AND OTHER MYSTERIES—by Harvard C. Pennington. This is the definitive work on the TRS-80 disk system. It is full of detailed "How to use," information with examples, samples and in-depth explanations suitable for beginners and professionals alike. The recovery of one lost file is worth the price alone. BK1181 \$22.50.*

MICROSOFT BASIC DECODED AND OTHER MYSTERIES—by James Farvour. From the company that brought you TRS-80 DISK AND OTHER MYSTERIES. Contains more than 6500 lines of comments for the disassembled Level II ROMs and six additional chapters describing every BASIC subroutine, with assembly language routines showing how to use them. Flowcharts for all major routines give the reader a real insight into how the interpreter works. BK1186 \$29.50.*

*No C.O.D. orders accepted. All orders add \$1.50 for the first book, \$1.00 each additional book, \$10.00 per book foreign airmail. Please allow 4-6 weeks for delivery. Questions regarding your order? Please write to Customer Service at the following address.

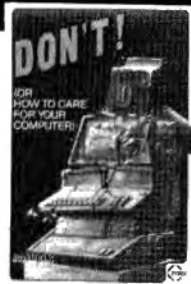

DON'T! (or How to Care for Your Computer)—by Rodney Zaks. In plain language, with numerous illustrations, this book tells all the do's and don't's of the care, preservation and correct operation of the small computer system. Specific chapters cover each piece of hardware and software, as well as safety and security precautions and help for problem situations. Have your computer work right the first time and keep it working. No technical background required. For all computer users. BK1237 \$11.95.

YOUR FIRST COMPUTER—by Rodney Zaks. Whether you are using a computer, thinking about using one or considering purchasing one, this book is indispensable. It explains what a computer system is, what it can do, how it works and how to select various components and peripheral units. It is written in everyday language and contains invaluable information for the novice and the experienced programmer. (The first edition of this book was published under the title "An Introduction to Personal and Business Computing.") BK1191 \$8.95*

MICROPROCESSOR INTERFACING TECHNIQUES—by Austin Lesea & Rodney Zaks—will teach you how to interconnect a complete system and interface it to all the usual peripherals. It covers hardware and software skills and techniques, including the use and design of model buses such as the IEEE 488 or S-100. BK1037 \$17.95.*

SPECIAL INTERESTS

MOD III ROM COMMENTED—Soft-Sector marketing, 1981. This book is not an instruction course on machine language, but rather an information source that you can use time and time again for writing your own program or patching old Mod I machine language programs. It contains an explanation of ROMs in the latest machine from Tandy, with most every location of the 14K ROMs listed, with comments. BK1235 \$22.50.

THE CUSTOM TRS-80 AND OTHER MYSTERIES—by Dennis Kitz. More than 300 pages of TRS-80 customizing information. With this book you'll be able to explore your computer like never before. Want to turn an 8 track into a mass storage unit? Individual reverse characters? Replace the BASIC ROMs? Make music? High speed, reverse video, Level I and Level II? Fix it if it breaks down? All this and much, much more. Even if you have never used a soldering iron or read a circuit diagram, this book will teach you how! This is the definitive guide to customizing your 80! BK1218 \$29.95.*

BASIC FASTER AND BETTER AND OTHER MYSTERIES—by Lewis Rosenfelder. You don't have to learn assembly language to make your programs run fast. With the dozens of programming tricks and techniques in this book you can sort at high speed, swap screens in the twinkling of an eye, write INKEY routines that people think are in assembly language and add your own commands to BASIC. Find out how to write elegant code that makes your BASIC really hum, and explore the power of USR calls. BK1221 \$29.95.*

THE CP/M HANDBOOK (with MP/M)—by Rodney Zaks. A complete guide and reference handbook for CP/M—the industry standard in operating systems. Step-by-step instruction for everything from turning on the system and inserting the diskette to correct user discipline and remedial action for problem situations. This also includes a complete discussion of all versions of CP/M up to and including 2.2, MP/M and CDOS. BK1187 \$14.95.*

PRICES SUBJECT TO CHANGE WITHOUT NOTICE



HOBBY COMPUTERS ARE HERE! If you want to come up to speed on how computers work—hardware and software—this is an excellent book. It starts with fundamentals and explains the circuits and the basics of programming, along with a couple of TVT construction projects, ASCII, Baudot, etc. This book has the highest recommendations as a teaching aid. \$4.95.* BK7322

THE NEW HOBBY COMPUTERS—This book takes it from where Hobby Computers Are Here! leaves off, with chapters on Large-Scale Integration, how to choose a microprocessor chip, an introduction to programming, low-cost I/O for a computer, computer arithmetic, checking memory boards... and much, much more! Don't miss this tremendous value! Only \$4.95.* BK7340

AN INTRODUCTION TO MICROCOMPUTERS, VOL. 0—The Beginner's Book—Written for readers who know nothing about computers—for those who have an interest in how to use computers—and for everyone else who must live with computers and should know a little about them. The first in a series of 4 volumes, this book will explain how computers work and what they can do. Computers have become an integral part of life and society. During any given day you are affected by computers, so start learning more about them with Volume 0. BK1130 \$7.95.*

VOL. I—2nd Edition completely revised. Dedicated to the basic concepts of microcomputers and hardware theory. The purpose of Volume I is to give you a thorough understanding of what microcomputers are. From basic concepts (which are covered in detail), Volume I builds the necessary components of a microcomputer system. This book highlights the difference between minicomputers and microcomputers. BK1030 \$12.95.*

NEW

INTRODUCTION TO WORD PROCESSING by Hal Glatzer. This book explains in plain language what a word processor can do, how to use one, how it improves productivity—especially in businesses that handle lots of words—and how to buy one wisely. No technical knowledge required, for all first-time users and those considering purchasing a word processor. BK1238 \$12.95

NEW

A USER GUIDE TO THE UNIX SYSTEM by Jean Yates and Rebecca Thomas. Here at last is a clearly written book that allows you to use the Unix operating system easily, and at a fraction of the time it previously took. If you're using, evaluating or simply curious about this system, this is your book. BK1242 \$15.99

NEW

WORDSTAR MADE EASY by Walter A. Ettlin. Now WordStar is as simple to learn as it is easy to use. This book teaches WordStar in 14 easy lessons, saving hours of hard work. It comes with a convenient pull-out Command Card. BK1239 \$7.95

KILOBAUD CLASSROOM—by George Young and Peter Stark. Learning electronics theory without practice isn't easy. And it's no fun to build an electronics project that you can't use. *KiloBaud Classroom*, the popular series first published in *KiloBaud Microcomputing*, combines theory with practice. This is a *practical* course in digital electronics. It starts out with very simple electronics projects, and by the end of the course you'll construct your own working microcomputer!

Authors Young and Stark are experienced teachers, and their approach is simple and direct. Whether you're learning at home or in the classroom, this book provides you with a solid background in electronics—and you'll own a computer that you built yourself! BK7386 \$14.95

TOOLS & TECHNIQUES FOR ELECTRONICS—by A. A. Wicks is an easy-to-understand book written for the beginning kit-builder as well as the experienced hobbyist. It has numerous pictures and descriptions of the safe and correct ways to use basic and specialized tools for electronic projects, as well as specialized metal-working tools and the chemical aids which are used in repair shops. \$4.95* BK7348

Use the order card in this magazine or itemize your order on a separate piece of paper and mail to 80 Microcomputing Book Department • Peterborough NH 03458. Be sure to include check or detailed credit card information.

FOR TOLL FREE ORDERING CALL 1-800-258-5473

RELOAD 80

by Art Huston

This month's column is for the newcomer to microcomputing and the TRS-80. It will deal with the question we most commonly get on the phone: How do I load this tape?

Beginners do not always know the difference between Assembly language source code and Basic. The important thing to remember is that Assembly language programs are loaded and then assembled using an editor/assembler; this is denoted on the LOAD 80 documentation card by the words

"needs EDTASM." In general, Assembly language programs are more difficult to use. Basic programs are loaded from the Basic prompt (>_) with the command CLOAD if you are loading from tape and LOAD "filename" if you are loading from disk.

The correct volume setting of the tape recorder is crucial to achieve a good load from cassette. This may differ from one tape to the next. If you have trouble, simply start at the low end of the volume scale and go up until you obtain a successful

load.

The alignment of your recorder's heads is also critical. If the tape sounds muffled this could be the problem. Consult the September 1981 RELOAD 80 column (page 314) for details.

Type CMD "T" before loading a tape under Model I Disk Basic. If you are using the Model III with either tape or disk, remember to toggle the low baud rate. Do this by responding 'L' to the 'CASS' prompt, or by POKEing 16913,0.

People often write to us complaining of program bugs and enclose a listing like Listing 1. The TRS-80 will often load a tape perfectly for several seconds and then start reading data incorrectly. If the program lists Basic keywords strung along

without colons or scrolls irregularly or changes print size, load it again. Even one line number interpreted incorrectly will cause an error to occur.

Please consult the February 1982 RELOAD 80 column for details on using LOAD 80 disks.

Errata

The program DIRECTRD was listed in April's RELOAD 80 column, but was not actually included. This is because our copy went bad.

A program was accidentally deleted from "The Philatelist's Friend" in the December 1981 issue, but was included on the LOAD 80 tape. The program is also listed in this month's Debut section. ■

May LOAD 80 Directory

Program	Title	Page	Comments
1	MUSIC	142	NONE
2	NAMESONG	234	NONE
3	EXPENSE	238	NONE
4	PERSPECT	242	NONE
5	RACES	252	NONE
6	HANDICAP	264	NONE
7	BANNER	282	NONE
8	SPCCHASE	292	NONE
9	FORE	298	NONE
10	GABBY	322	NONE
11	TESTFILE	330	NONE
12	MONEYDOS	382	NONE

Program Listing 1

```
68 CLS:QL=8:X=326:FORG=1TO8:PRINTEX,A(G);:X=X+64:NEXT:QI=6:PRINT
@22,AZTAB(68)*# 2
78 PRINT@837,CHR$(170)STRINGS(5,183)CHR$(179)STRINGS(5,187)AB
88 PRINT@902,CHR$(153)CHR$(166)CHR$(199)CHR$(153)CHR$(166)
98 PRINT@965,CHR$(154)AFCHR$(165)CHR$(19nSMKd$Pb)hRRESEtGOTOMKdS
FbljrvtPOKEKILLappLOCdATAMEMdENDjfhXD$SYSTEMGETRETURMERGEDIM@dA
TAERRORSYSTEMLINEBRESERt@h@DATARETURNRUNRETURMERGE@LINEKILLDEF$N
GCLSDIMGETDvugEND1*dxDERRORLINEBRESERt@OUTRETURNDINRAMDMDIMBERR
*18* 88H
```

Simput

UTILITY PROGRAM FROM HIKARI GROUP

SIMPOT:

- Easy to use
- Almost limitless record length
- Access subrecords with numbers
- Get exact subrecords you put in, no more, no less
- Compatible
- No knowledge of disk basic required

SIMPOT is a flexible random access program for the TRS 80 Model I* that lets you manage extremely complex data with great simplicity. It allows you to create records from one byte to more than 85,000 bytes long, with as many subrecords as you need, and it can be used with Microsoft's Basic Compiler. It eliminates many disk access statements and saves disk space.

SIMPOT is simple. The package includes a comprehensive instruction book and easy to follow sample program. Once you've tried SIMPOT, you'll never go back to normal random access method. SIMPOT has been tested to be compatible with any TRSDOS* compatible languages.

For more information write: Hikari Group, 3032 Fourth Avenue West, Seattle, Washington 98119. Available on disk for \$29.95. If you have only one disk drive, a tape is available. (206) 382-6632.

*Trademarks, Tandy Corporation.



508

**LOAD
80
LOADS
EASY**



LOAD 80

**ELIMINATE HOURS OF
TYPING AND
AGGRAVATION**

**LOAD 80 cassettes for BACK ISSUES
of 80 Microcomputing now available**

In the April, 1981 issue of 80 Microcomputing we introduced LOAD 80 to save you the time and trouble of typing our programs yourself. LOAD 80 cassette tapes contain dumps of the major program listings in 80 Microcomputing.

If you have not yet ordered any LOAD 80 tapes and wish you had, don't worry. We are now offering a "back issue" cassette program. You can order any LOAD 80 cassette from April, 1981 to date for \$9.97. Back issues of 80 Microcomputing are also available with the LOAD 80 cassettes for \$3.50. With the complete documentation found in the companion magazine issue, you should have no difficulty loading any of 80's major programs.

Please send me the following:

month year month year
Tapes _____ **Magazines** _____

ITEM	COST	QTY.	TOTAL
LOAD 80 Tapes add \$1.50 per tape for postage and handling	\$9.97		
80 Microcomputing add \$1.00 per magazine for postage and handling	\$3.50		
TOTAL			

Check Enclosed Bill my: MC AE VISA

NAME _____
 ADDRESS _____
 CITY _____ STATE _____ ZIP _____
 CARD # _____ EXP. DATE _____
 SIGNATURE _____ INTERBANK # _____

Please allow 4-6 weeks for delivery
 LOAD 80 • 80 Pine Street • Peterborough NH 03458
 Attn: Debra Boudrieau

Circuit Analysis. Linear and transient circuit analysis programs. 10 to 15 nodes. Built-in models for transistors, op-amps, transmission lines. Plots amplitude and phase. Available for TRS-80 Disk BASIC 48K, CP/M and H-89 computer systems.

LCA (Linear Circuit Analysis) _____ \$129.95

TCA (Transient Circuit Analysis) _____ \$129.95

TCCA (Both of the above programs) _____ \$169.95

Data Base Management for the TRS-80.

DBM-1 is designed to be sophisticated yet easy to use. Extensive screen prompts with cross reference to the documentation to make this program one of the best documented on the market. 256 byte fields, 256 byte field names, machine language assisted sort, flexible report generator with field arithmetic and column totals. Available for TRS-80 with 48K and one or more disk drives.

DBM-1 _____ \$99.95

DBM-1 _____ \$199.00 Purchased with LDOS 5.1 (Specify I or III)

TRS-80 Graphics Package. GRASS is a superb graphics package and machine language overlay loader. Create complex screen graphics with a few simple commands in BASIC or machine language. The overlay loader allows multiple machine language programs to be called from the disk while in BASIC. GRASS _____ \$59.95

Manuals available for any of the above packages for \$15.00.

To order call (505) 255-6451 weekdays between noon and 6:00 p.m. Mountain time. Ask for a catalog. MasterCard and Visa accepted. Dealer inquiries invited.

**AUTEL
ELECTRONIC CO.**

MICRO-COMPUTER SYSTEMS AND SUPPLIES
 146 WISCONSIN, NE • ALBUQUERQUE, NM 87108 ✓297

TRS-80* OWNERS

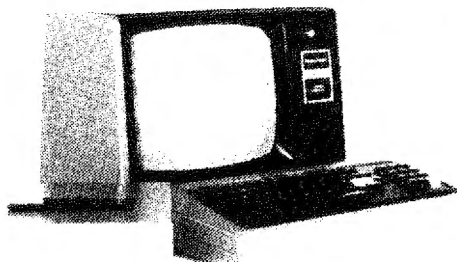

BETA-80

**LOW COST ARCHIVE OR DISK
BACK-UP TAPE STORAGE SYSTEM**

The BETA-80 is a low cost, high speed, direct access digital tape system which provides one megabyte of storage per drive. The dual drive configuration provides two megabytes on line. The BETA-80 has been interfaced to the Model III TRS-80* for use in backing up costly diskettes. It provides direct access at better than 100 inches per second and will store 10 single density 5-1/4" diskettes on a standard C60 cassette.

Write or phone MECA for details.

meca - (714) 365-7686

7350 Acoma Trail, Suite 3 - Yucca Valley, CA 92284

✓304
 *Manufacturer's Registered Trademark

80 Medical Opinion

by Philip R. Mills, M.D.

"Even stuffy medical journals have articles on computerization."

This year may well be the year of the microcomputer in the field of medicine. Physicians have been purchasing microcomputers in record numbers. Several small journals devoted to micros in medicine are available. Even stuffy medical journals have articles on computerization. One orthopedic journal which I receive has just begun a regular column devoted to the subject. The surface has only been scratched, however; if you can recommend a program on diabetes, blood gases, thyroid profile, health education, life expectancy, diet counseling, filing system, statistical analysis, or any program of interest to a physician, please write to me.

For any business the accounts receivable constitutes a most important portion of successful operation. Unfortunately, in medicine and dentistry, patient accounts are far too complicated and numerous to use any of the standard business accounts-receivable programs. To provide small clinics with automated patient billing, various software houses have been writing medical packages for the Models I, II and III. The recent releases are vastly superior to earlier attempts. If your clinic is using an older medical or dental program, it may pay to investigate one of the new Model II billing packages. Our next several columns will be devoted to billing packages. We will cover packages for the Model I, Model II and Model III.

The MS80 Dental Financial Management System (clearly benefiting from the abbreviation FMS) developed by MICRO/SYS80 Inc., 236 Waverly Rd., Southampton, PA 18966 (215) 355-5706, is a quality program. There are advantages to purchasing programs developed by experienced software houses. In 1978, the authors of FMS developed their first dental billing package. Written in Basic for the Model I, it was later revised for the Model II. Because of the limitations inherent in Basic, a complete rewrite was made in 1981 using TRSDOS 2.0A and Radio Shack's Cobol.

FMS is a true turnkey system. It is entirely self-prompting. From the time the computer is turned on, the user simply re-

sponds to questions or keys in patient data as the screen indicates. The video capabilities of the Model II are utilized nicely, and reverse video highlights nicely all editable screen information.

The 191 pages of documentation are outstanding. The manual is printed with selectric-quality print and has three major sections.

The first section is an easily understood tutorial which walks the user through the many functions of the system at a comfortable pace. Every video screen and option is covered and any areas of particular importance are highlighted. Since FMS was specifically written for the Model II, all operating instructions, including back-up, are specific to the Model II. (This gives it an edge over most CP/M programs which are able to provide only general start-up instructions, broad enough to fit many different computer models.) The tutorial section closes with a question-and-answer chapter. Questions such as, "How can we 'write off' this account?" are addressed. Our billing clerk was able to understand the tutorial with no outside assistance.

The second section of the manual is for reference only and is very complete with detailed specifications for every screen, option and function. In my opinion this portion of the manual was unnecessarily difficult to use since it was arranged in alphabetical order rather than organized by

nine choices (including six submenus) are listed:

- 10 Account Maintenance Menu
- 20 Patient Maintenance Menu
- 30 Payment Processing Function
- 40 End-of-Day Processing Menu
- 50 Billings Option Menu
- 60 Monthly Processing Menu
- 70 Peripheral Maintenance Menu
- 80 Patient Processing Function
- 90 End System

If "50" is entered, the Billing Option Submenu appears:

- 51 Account Billing Function
- 52 Insurance Billing Function

All submenus can be bypassed. In the above example the Billings Option Menu could have been bypassed by entering 51 or 52 directly from the main menu. The response time is nearly instantaneous and entries do not require pressing Enter.

The program provides for 200 dental procedures (the advertisement incorrectly states 300), 20 producers (dentists, hygienists and so on), 20 complications (asthma, penicillin allergy, among others), and 20 insurance carriers.

Patient accounts are limited by disk space to 4,000 patients with 2,000 active billing accounts. If a hard disk is used, this number can be increased indefinitely. Each patient record allows up to five complications to be listed, as well as two

"Our billing clerk was able to understand the tutorial with no outside assistance."

the menu sequence. There is no index, but in most cases the table of contents is sufficient to serve this function.

The last section of the manual contains appendices with all start-up instructions, back-up instructions, and other information such as where to order forms.

The compiled program contains nearly 500K of instructions. A main menu provides 35 options. To avoid cluttering the screen and confusing the billing clerk only

phone numbers, birthday, sex, next appointment, recall date, and dentist.

One of my main criticisms of Radio Shack's Model I Medical Office System was the difficulty our office had in changing over from our manual pegboard system to this automated billing system. It took us a month and much overtime. Finally we abandoned the system, leaving our billing clerk resistant to future computerization. The MS80 Financial Manage-

MULTIDOS

For Your TRS-80™ Model I and Model III

★ Most **EFFICIENT** Disk Basic Interpreter!

A true Z-80 Basic. Others claim to have a NEW Basic, but their cumbersome archaic code cannot measure up to the speed and size of **SUPER-BASIC**. Seeing Is Believing!

★ Most **COMPATIBLE** Operating System!

Model III **MULTIDOS** will Automatically Read (without reconfiguring system between reads —without modifying source media)

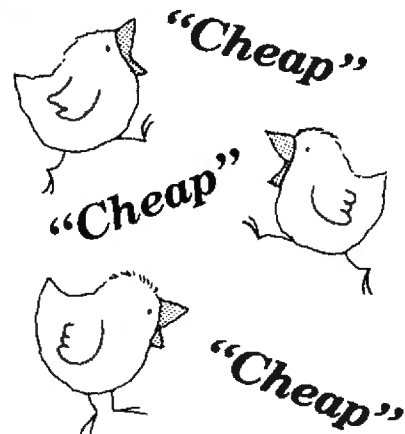

MULTIDOS Model I Single Density	LDOS Model I Single Density
MULTIDOS Model I P Density	LDOS Model I Double Density
MULTIDOS Model I Double Density	LDOS Model III
DOSPLUS Model I Double Density	NEWDOS/80 Model I Double Density (unadulterated)
DOSPLUS Model III	NEWDOS/80 Model III (unadulterated)
PERCOM DBLDOS	

UTILITY TO READ TRSDOS MODEL III, VERSION 1.3.

Other Model I Single Density Operating Systems Must Be Altered (via System Utility) To Be Read By **MULTIDOS** Model III. **MULTIDOS** Model I Doesn't Care! It Just Reads 'Em. (Hardware Modification Required To Read Double Density Diskettes)

★ Most **PORTABILITY**

Mix & Match Model I and Model III MULTIDOS Diskettes.



— MAIL ORDERS —



VISA & MasterCard
WELCOMED

Foreign Orders Add \$15.00

Cosmopolitan Electronics Corporation

P.O. BOX 234
PLYMOUTH, MICHIGAN 48170

— TECHNICAL INFORMATION —

Cosmopolitan Electronics Corporation

C/O VERNON B. HESTER
42403 Old Bridge Road • Canton, MI 48188 • (313) 397-3126

\$79⁹⁵

Plus \$3.00 For
Shipping & Handling

Michigan Residents
Add 4% Sales Tax

COD Orders Add \$1.50

★ For Model I Orders Only ★
Please Specify Single, Double
or P Density.

Personal Checks Take
2 Weeks To Clear

NOW AVAILABLE FROM

COMPUTER SHACK

1691 Eason
Pontiac, Michigan 48054
(313) 673-2224

POWER SOFT

11500 Stemmons Expressway
Dallas, Texas 75229
(214) 484-2976

BYTES & NAILS

5110 6th Avenue
Sioux City, Iowa 51106
(712) 274-2348

SIMUTEK
COMPUTER PRODUCTS, INC
4877 East Speedway
Tucson, Arizona 85712
(602) 323-9391

ment System, however, is remarkably easy to install in the office. In fact, the manual contains a chapter devoted to painless computerization. FMS gives the option of installation all at once (in our experience a horrendous task) or gradual changeover (our clinic's recommendation). Gradual changeover is accomplished by entering patients into the computer as they have dental appointments or as payment is received.

Access to patient information is immediately available by either patient name or number. No sorting is ever required making it by far the fastest program I have used to date. Patient billing is simplicity itself. All prompts for information are clear and easily entered. Patients are charged using procedure codes. Standard charges may be overridden at any time. New procedures may be entered immediately. A return appointment is entered at this time with a date flagged to send a reminder to each patient of his next appointment. Mailing labels are produced if desired for statements, recall cards, and appointment notices. Numerical entry is enhanced by removing any slashes, dashes, or parentheses from dates, phone numbers, social security numbers, and so forth; the program automatically supplies these itself. At the conclusion of each day, you can print out the next day's appointment list.

A very helpful option which I have seen on no other medical package is the capability to print up the charge slips on the next day's patients. This charge slip contains the account and patient name and phone number, past-due balance (if any)

and date of last payment. This makes it convenient for the office manager to discuss the status of the account with the patient if necessary. It also provides a form for the dentist or other producer to write in all new charges.

Patient statements are very versatile. Three lines are provided for a seasonal greeting. Every patient account can be individualized—billed, not billed, insurance only, budget, and so on. Any patient can receive or not receive dunning messages on his statement. Your standard 30, 60, and 90 day dunning messages can be changed easily. A pre-treatment authorization form can be sent to a third-party carrier prior to treatment for payment approval. Third-party billing forms can be standard ADA forms or SUPERBILL format on blank paper.

A reconciliation statement is printed daily. Numerous other accounting reports can be generated including full account aging reports, patient lists, billing reports, and insurance aging reports. Management reports include procedure analysis and producer analysis. All reports can be printed alphabetically or by account number sequence. Complete complication lists, procedure lists, and producer lists are also provided.

An excellent convenience feature of the program is the arrangement of report printouts. The reports are arranged to require an absolute minimum of printer form changing. This feature will appeal strongly to any busy office personnel. Standard forms are utilized where possible, but any format is available from MS80 by request.

Insurance billing is always compli-

cated. The program simplifies this billing. All patients are arranged under the account of the person responsible for payment. This is a better solution than having a separate account for each patient.

Although this program is excellent, there were a few areas that irritate me. All prompt response entries require uppercase. Lowercase responses are ignored. My personal preference is lowercase. Account-name searches differentiate between upper and lowercase, which I feel is an inconvenience shared by most accounting packages. This program shares another inconvenience with most other packages: Date changing is awkward and requires rebooking.

The program provides an option to schedule the appointment time. Date only is available. This is certainly no major limitation.

No provisions are made to enter patients with past-due balances. All patients must be aged by the program itself. Any outstanding balance must be originally entered as a current balance. Most practices would choose this method of aging anyway, so this would prove of little inconvenience.

No integrated accounting programs are available for this FMS. Also not provided are any reports comparing prior months, years or collection percentages, but neither does any other medical office system I have reviewed.

Another feature absent from every package to date is a simple way to update the procedure-fee schedule. It should be possible to update all charges by a certain percentage without changing each

Scotch[®] Diskettes

Rely on Scotch[®] diskettes to keep your valuable data safe. Dependable Scotch diskettes are tested and guaranteed error-free. The low abrasivity saves your read/write heads. They're compatible with most diskette drives.

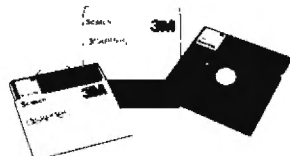

(800)235-4137

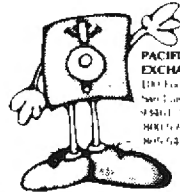

PACIFIC EXCHANGES
1301 1st Street
San Francisco, CA 94101
NRE 02/82/100
NRE 02/82/100

Dealer Inquiries Invited

✓ 207

Introducing...



Frog Prince Software

PROGRAMMERS: We are seeking outstanding entertainment programs for publication. Unique, challenging programs for the IBM PC, the TRS-80 Color Computer and other computers with high-resolution color graphics capabilities. Write for our submissions kit.

Frog Prince Software
P.O. Box 970
Bowling Green Station
New York, New York 10274

✓ 531

☆☆ SUPER[™] ☆☆☆ ISA's DATABASE

The only DBMS with all these features:

- ★ PROVEN in one year of test marketing
- ★ TOUGH, reliable file structure
- ★ MENU driven for simplicity and easy use
- ★ ARITHMETIC with stored calculations
- ★ FAST set-up and report formatting
- ★ CLEAR user-oriented documentation
- ★ PRINTS totals & subtotals - mail labels
- ★ REFORMATS and merges data files
- ★ MULTI-DISK files: Up to 128K records
- ★ SORTS full disks on up to 40 fields
- ★ PRODUCTION input of repetitive data
- ★ COUPLES to word processor & statistics
- ★ POSTS transactions to master file
- ★ SEARCH by strings, ranges, comparisons
- ★ DATA COMPRESSION: Over twice as many labels as the other system

For TRS-80[®] Models I, II, & III - 250.00

Ask your Dealer or Write:

Institute for Scientific Analysis, Inc.
P. O. Box 7186, Dept. M-1
Wilmington, DE 19803 (215) 358-3735

*T.M. Tandy Corp.

✓ 351

BLOCK BREAKER



A fast and furious action game designed to challenge players of all ages and skills! Special features include:

- 9 levels of play
- sound effects
- SAVES TOP TEN SCORES
- machine language

For the TRS-80* Model I, Level II 16K or Model III 16K
Price of \$14.95 includes shipping and handling.
To order call (513) 435-5866 or send check or money order to:



Cedar Software Co.
1943 Woodson Court
Centerville, Ohio 45459
Dealer inquiries invited
*Trademark of TANDY CORP.

EIVABLELARGECAPACITYACCOUNTSRECEIVABLE

EIVABLELARGECAPACITYACCOUNTSRECEIVABLE

LARGE CAPACITY

ACCOUNTS RECEIVABLE FOR MODEL I/III

5000+ CUSTOMERS
15000+ TRANSACTIONS

BALANCE FORWARD. 99 TRANSACT. CODES. 30-60-90-120 AGED. STATEMENTS SHOW DATE/INV#/DESCRIP/AMT (WITH AGEING). SELECTIVE FINANCE CHARGES & RATES. FAST ENTRY POSTING W/AUDIT REPORT. SUB-ACCTS. % OF CREDIT LIMIT. DATE OF LAST PAYMENT. SALES ANALYSIS SPECIAL 90 DAY ACCOUNTS LABELS RETAIL & PROFESSIONALLY USED 2 YEARS.

\$100.00
(REQ. YOUR DOS 32K 2 DISKS)

HOLMAN D-P SERVICE ✓ 355
2059 WEST LINCOLN 3.00 S&H
OROVILLE, CA 95965 VISA OR MC
916-533-5992 3PM-9PM COD*
*COD (CASH, CERTIFIED CK, MONEY ORDER)

TAKE A BYTE OUT OF YOUR SOFTWARE COST!



Save 20-40% on all major Brands of micro-software

90 day guarantee-when you're happy, we're happy!

Gigantic inventory of old and new releases.

Overnight shipment by UPS-no per item handling fee.

We credit orders \$1.00 when you call from out of 213 area.

SOFTWARE GALORE

For free catalog/orders call 213-827-1851 (8 am - 5 pm only) New National Direct
Phone Number 1-800-423-6326

TRSDOS ↔ CP/M

with

REFORMATTER™

Model II users! Convert files between TRSDOS and CP/M!

- REFORMATTER runs under TRSDOS
- Operates on single drive system
- Converts in both directions
- CP/M operating system not needed
- All TRSDOS record lengths supported
- Initializes blank CP/M diskette
- Displays or dumps CP/M files
- Manipulates CP/M directory under TRSDOS

\$249.00 from stock. CP/M ↔ IBM and CP/M ↔ DEC versions of REFORMATTER also available at \$249.00 from MicroTech Exports, Inc., 467 Hamilton Ave., Palo Alto, CA 94301 || Tel: 415/324-9114 □ TWX: 910-370-7457 MUH-ALTOS □ Dealer & OEM discounts available.

MODEL III TRS-80®

Software on Disks!

At last! All Model III.

Put it in — Watch it run.

GUARANTEED — SEND FOR FREE CATALOG. INCLUDE \$9.95 FOR DISK VERSION AND A FREE PROGRAM.

STAR★WARE™

Rt. 5, Box 277-C
Benbrook, TX 76126

Subscription Problem?

80 Microcomputing does not keep subscription records on the premises, therefore calling us only adds time and doesn't solve the problem.

Please send a description of the problem and your most recent address label to:

80 Microcomputing
Subscription Dept.
PO Box 981
Farmingdale, NY 11737

Thank you and enjoy your subscription

WILD CAT

REMARKABLE TRS-80 DISK DIRECTORY CATALOGUE SYSTEM

Catalogue contains Filespec, FIRST LINE REMARK, disk ID, disk name, disk date and free space.

Model I using TRSDOS 2.3 or any Version NEWDOS Uses fast machine code for reading and sorting.

\$39.95 + \$2.00 S/H Req 48K. Two 5" Drives Satisfaction guaranteed or return within 10 days.

DONALD M. FIELDING
2207 N.W. 61st PLACE • MARGATE, FL 33063
(305) 972-6744

Dealer Inquiries Invited
TRS-80 and TRSDOS - Trademark of Tandy Corp
NEWDOS - Trademark Apparat Inc.

softbyte computing

announces... ✓398

STAR SEARCH ASTRONOMY GUIDE Instantly display a map of the skies overhead for any date and time entered that plots the brightest stars, double stars, star clusters, nebula and the external galaxies. \$19.95

DATA-FILE MANAGER A complete information filing and retrieval system that includes an alpha & numeric sort, user-defined record formats of up to 240 characters and 12 fields, multi-field search and totals, and auto memory size recognition. \$19.95

STOCK CHART GRAPHER Charts any stock's trading prices for up to 60 days, weeks, etc. along with volume of shares traded, price moving average and relative price change. \$19.95

THE COUPON SHOPPER A convenient and organized way to keep records of your redeemable coupons on hand that also matches those coupons to your program-prepared shopping list. \$9.95

All programs are furnished on cassette for Model I or III with at least 16K. Disk owners inquire as to disk availability and prices. Overseas add \$3.00 and CT residents add sales tax.

Softbyte Computing, Box 217, Wallingford, CT 06492

charge individually.

Since the package is written in Cobol, in-house enhancements will be very difficult. A fully operational demonstration version is available for \$30. The demonstration version is slower than the complete FMS version and limited to 20 patients. Otherwise, it is identical to the full version and includes full documentation. This provides an excellent way to test the program for your dental practice. It also gives you the opportunity to arrange for any special needs your practice requires and lets the company make any customization necessary for your office.

Software support is vital and FMS comes with a guarantee that any programming errors will be corrected without charge. (A policy which I believe all software houses should have.)

The package requires a Model II, four disk drives, and an 80-column line printer. (A hard disk is far superior to four disk drives, and I personally recommend it.) The program is reasonably priced at \$1,600, which includes full support for one month.

Although there are some significant dif-

ferences between dental billing and medical billing, there are many similarities. I have reviewed this package with a dental friend to make certain the review is accurate. He was so impressed with the ease of operation that he is considering purchasing a Model II just to have the program.

A medical package is scheduled for release within a few months. A version for CP/M is also to be released "shortly." ■

Ed. note: Below is a letter from Frank Weiss of MICRO/SYS80 commenting on Dr. Mills' appraisal of their program.

Dear Dr. Mills:

Your review of the MS80 System is precisely accurate, well written, and certainly friendly to our system.

The few criticisms you relate are also accurate and quite constructive. Your suggestion concerning an index to help find specific sub-functions is also well taken and I will include an index with the next manual publication.

The variation between the 300 procedures advertised and the system limit

of 200 is actually a mistake in the screen utilization display. There are 300 allowed and we will change the program to reflect this amount. We have also heard from other sources that it would be beneficial to allow entry of past-due balances when creating the account file, and we are considering adding this feature.

We are working on a new function to allow the user to compose simple letters, and have the system use the account file names and addresses to produce letters to all accounts, selected accounts (such as those with a past due balance), or individual accounts. I hesitate to call this a word processing function since the text composition will not be as versatile as Scripsit or Electric Pencil, but rather like the way we allow text entry for the statement messages or the dunning messages.

Again, thank you for your time and interest.

Sincerely,
MICRO/SYS80
Frank A. Weiss ■

Holmes Engineering

expanding microcomputing horizons for TRS-80® Model I/III and PMC®-80/81

MORE THAN AN EXPANSION INTERFACE!



EXPAND your computer with the **HOLMES** expansion mainframe and one or more plug-in modules.

- Mainframe includes case, power supply, connectors (2 mainframe styles available).
- Single/Double density disc module
 - State-of-the-art LSI data separator
 - 5" & 8" drives, single and double density (optional)
 - Compatible with standard hardware & software
- 80 Column Video Module
 - 80 character x 16 lines for TRS-80® monitor
 - 80 character x 25 lines for standard monitor
 - 80 x 25 mode supports Model II video functions
 - Software/patches for many popular programs
- RS-232 / Modem Module
 - Software compatible with RS systems
 - Supports standard operating modes
- Other modules are being developed.
 - A single-module case is available to support only ONE module.
 - Due to the number of options available, please call or write for prices.

SPEED UP YOUR COMPUTER and add a printer

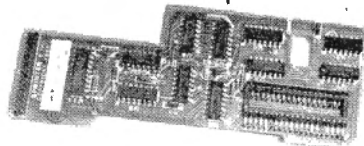

The **SPRINTER II™** plugs into the Z-80 socket in your computer case with no soldering.

- Select "NORMAL" or 4 MHz operation via the "OUT 254" software command (or add a switch for hardware control)
- Automatic slowdown for disc & I/O operations
- Wait function allows use with slow ROM's.
- Includes **FAST Z-80B MP.**
- For \$24.50 we'll install a standard parallel printer port on your Sprinter II™

SPRINTER II™ \$99.50
printer option \$24.50
printer cable \$19.50

48 K Memory INSIDE your Keyboard

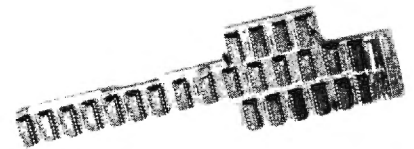

IM-2™

The **INTERNAL MEMORY™** plugs inside your computer to give you 48k of reliable memory.

- simple installation
- easily removed
- guaranteed 4 MHz operation
- extremely reliable
- compatible
- thousands in use throughout the world!

IM-1 (32k) \$86.00 (66.00 less RAM)
IM-2 (48k) \$139.50 (99.50 less RAM)

See reviews of the **INTERNAL MEMORY™** in 80 Microcomputing® (Dec. '81) and 80 US Journal (March '82)

All products are completely assembled and tested and come with a one-year warranty and a 30-day "no questions asked" return privilege.

Please add \$3.00 shipping in U.S. & Canada; all others add 15% shipping & handling

3555 South 3200 West Salt Lake City, Utah 84119 (801) 967-2324

prices subject to change without notice.

✓153

Send S.A.S.E. for more information



Dealer Inquiries Invited

Supercharge Your Micro's Performance With



The Professional Operating System with CP/M™ Compatibility

- **Spectacular Performance.** Programs run 3 to 10 times faster compared with TRSDOS or CP/M. Benchmark results up to 20 times faster obtained with some applications by independent "firm".
- **Double-Sided Drive Support.** Provides 1.25 Megabytes of storage per 8" double-sided/density disk. Intermix any combination of single or double sided drives on line.
- **Expanded Directories.** Store larger number of files and more information per disk.
- **Automatic Density/Side Recognition.** Detects changes in disk format automatically. Change disks at any time without compromising data or "BDOS/Read-Only" errors.
- **Fast Disk Backups.** Copy a complete 8" SS/DD diskette (610K) in less than 80 seconds. Copy a double sided/density diskette (1.25 Megabytes) in less than 1 minute 45 seconds!
- **Hard Disk Drive Support.** Supports large hard disks in excess of 1,000 Megabytes without partitioning.
- **Advanced Utilities.** Complete set of disk utilities: system, date and time functions, communications channel interface, etc. provided as standard features.
- **Enhanced Automatic Print Spooling.** Run multiple printers simultaneously, support for multiple queues and printers is standard feature on spooling versions.
- **CP/M Compatibility.** Virtually any CP/M (version 2.x) program will run under TURBODOS without modification. Also fully media compatible with standard CP/M-format diskettes.
- **Advanced Mainframe-like features.** Includes read-after-write validation of all disk update operations, type-ahead buffers, incremental disk backup utility, password/log-on security, system date and time functions, accepts string of multiple commands, and numerous other capabilities not available under CP/M or TRSDOS. Multi-user, networking versions also available.

TRS-80 Model II
and Xerox 820 versions

\$195

Dealer and OEM inquiries invited

Data-Rx, Inc.

Special Introductory Price
Easily adaptable to any Z80-based computer.

(408) 375-2775 • 686 Lighthouse Avenue • Monterey, 93940

TURBODOS is the registered trademark of Software 2000
CP/M, MP/M, and CP/NET are registered trademarks of Digital Research

✓292

Attention: European Subscribers

Due to shipping problems in Europe, we are asking our subscribers to send us their most recent mailing label from 80 Microcomputing. If you are unable to provide us with a label, please send us your name and address, and tell us at what point you are presently in in your subscription. This information is very necessary in order to solve a forwarding problem, so we are asking for your co-operation in this matter. Please direct all information to: Attn: Doris Day, 80 Microcomputing, 80 Pine Street, Peterborough, NH 03458.

COMPUTER AIDED INVESTMENT

Had you ever missed opportunities to purchase stocks at their low points, and/or had hesitated to sell and resulted in financial losses?

One of the secrets for success in the STOCK-MARKET is timing.

A computed program, STOCKCHART-I™, for usage on the TRS-80* models I & III, APPLE II*, & ATARI-800* computer systems, will time the stocks in your portfolio for BUY & SELL opportunities. The BUY & SELL signals are based on a unique price-trend analysis technique developed by Micro-Investment Software. It only requires the weekly high, weekly low, and the last trading day of the week's close stock prices. With this program, you no longer need to guess or listen to rumors for your investment decisions.

Aside from its ability to assist you on deciding when to BUY & SELL, it also will generate a price-chart from the High, Low, and Close stock prices. The user has the option to select the price-chart to be generated onto the video screen or to the line-printer. And many other useful features. . . .

— STOCKCHART-I™ —

Features:

- generate BUY/SELL signal
- generate price-chart from High, Low, & Close stock prices
- data entry in newspaper format (accept fractions)
- SPLIT mode for price data readjustment on stock split
- EDIT mode for data changes and/or corrections
- STATUS mode display BUY/SELL signal for all stocks on file
- Fully menu driven, user friendly
- LIST mode for price data print out onto video or line printer

Sample Results:

- Tandy Corp.-5/19/80 to 9/07/81
3 BUY/SELL signals
ROI: 163%
- Hewlett Packard-5/25/80 to 8/30/81
4 BUY/SELL signals
ROI: 42%
- Adv Micro Dev.-5/12/80 to 6/22/81
3 BUY/SELL signals
ROI: 51%
- Nat'l Semi.-5/25/80 to 6/22/81
3 BUY/SELL signals
ROI: 40%
- Storage Tech.-5/18/80 to 6/22/81
3 BUY/SELL signals
ROI: 111%

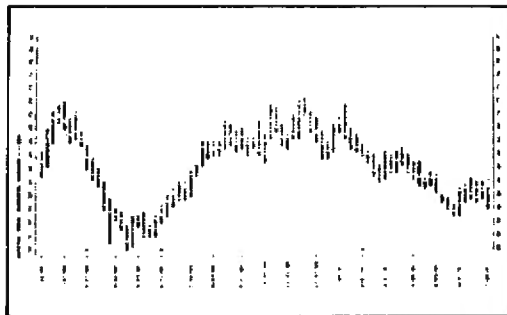

An Investment Tool for the Serious Investors

System Requirements:

- cassette version - min. 16K RAM
- disk version - min. 32K RAM, 1 disk drive
- printer optional

To order, see your local computer/software dealers or send check, money order, or C.O.D. to:



Micro-Investment Software
9621 Bowie Way
Stockton, CA 95209

cassette version \$79 per copy
disk version \$99 per copy

TM - STOCKCHART-I is a trademark of Micro-Investment Software
*trademare of TANDY CORP., APPLE COMPUTER, & ATARI respectively
ROI - return on investment

Dealer Inquiries Invited

Visa and Mastercard welcome. (209) 952-8833

✓111

THE EXCLUSIVE ORACLE

by Dennis Kitz

"I think the Color Computer wipes even the legendary Apple right off the technological map."

Q. We Color Computer owners would like to see a monitor interface with switchable 32/64/80 character display.

*Howard B. Culbreth
Tabb, Virginia*

How about 64 columns for the Color Computer? I know you have done a lower-case modification, so this shouldn't be too hard to work up. Eighty columns has been done for the Apple, so it should be possible to get 64 on the Color Computer.

*Gary Teter
Paradise, California*

I would be interested in your thoughts on accomplishing an 80-character display width using either a black-and-white or color set. Can the software be POKED to achieve the 80-character width?

*Thomas V. Schill
Huntington, West Virginia*

A. I would like to take this month's entire column to explain the Color Computer's video display system to readers Culbreth, Teter, Schill and nearly a hundred others who have written. It is capable of both more and less than other methods of video display.

A good place to start is by asking "what is a computer video display?" A simple question? Well, perhaps not. Folks who have used only one type of personal computer tend to think that a given manufacturer's method is *the* way a video display works. I believed that, too; once you feel comfortable with the system you are presently using, you start thinking that its design must have been determined by some digital deity way back during the misty genesis of computer technology.

But there is no standard system; in fact, there is no system that even begins to resemble a standard. Counted among displays presently manufactured are variants on raster and vector displays; 24, 32, 40, 48, 64, 80 and 132 characters per line (and others); 5 by 7, 7 by 9, 8 by 12, and other dot matrices on raster displays; up-

per and lowercase, special symbols and other alphabets; user-definable characters; resolution from coarse block characters to 1,000-dot lines with up to 256 colors and/or levels of grey scale.

In reality, the often mentioned "standard" (an 80-character, 24-line display) is ignored by the majority of major microcomputer manufacturers. Consider: TRS-80 Models I and III and PMC-80 (32/64 by 16); TRS-80 Model II (40/80 by 24); TRS-80 Color Computer (32 by 16, hi-res definable to 48 by 24); LNW-80 (32/64 by 16, hi-res definable 48, 72, 80, etc.); Apple II (40 by 24, hi-res definable to 64 by 24); Ohio Scientific C1 (24 by 24, extendable to the borders to create 32 by 32 with some not visible); Ohio Scientific C4 (32/64 by 24); Commodore PET (64 by 24); Commodore VIC (24 by 24); Osborne OS-1 (50 by 24). The list goes on.

Most old timers—those working in computers for more than five years—claim that the 80-column display is a heritage from the IBM standard 80-column punched card (remember punched cards?). But ironically, even machines such as IBM System 23 minicomputers use only a 40-character line. Heritage or not, however, it is a useful display size, since most business correspondence and reports set margins for about 72 characters per line (or so my 1962 edition of *Rowe's College Typing* insists).

On the other hand, 64 characters per line works very easily from a software and hardware standpoint. Sixty-four, being 40 hex and one-quarter of 100 hex, is quick to program and evaluate as an end-of-line trip value. It is also a neat binary number for digital counter chips, allowing a run from 000000 through 111111 (0 to 63), and restarting the next line when a carry drops off the end—nice stuff.

And nice stuff is what is critical to making an inexpensive personal computer. Back in 1976 when the Model I was still a gaggle of wires, that easy 64-character-per-line hardware made the video display attractively economical. Yet even with that economy, the computer's video storage, control and display circuitry used 35 integrated circuits, two transistors, adjustable and fixed resistors, capacitors

and miscellany—nearly half of the *total* hardware used in a TRS-80!

But turn back for a moment to the two different kinds of video systems: vector and raster display. Vector display uses cathode ray tube (CRT) hardware that allows the electron beam's position on the screen, its direction of motion, and its intensity to be controlled by the computer. If a screen is to display an image, the electron beam is moved (vectored) to that position on the screen, turned on, and moved in the shape of the object to be drawn. It is redrawn as often as the software allows it to be. You may have seen some of those sophisticated video arcade games—the ones in bars, not living rooms—which use vector display systems for exquisite detail. But because of its expense, the vector display method is used only in sophisticated equipment; no present-day microcomputers include a standard vector display system.

Raster display is more familiar. The raster is the set of horizontal lines visible across the screen of an ordinary television set. The electron beam is continuously swept across the screen by hardware that is inside the television set or monitor; it is not controlled by the computer. Therefore, in order to display characters, the computer must provide intensity information (dot on or dot off) in precise synchronization with the inexorable sweep of the electron beam. In the United States, that means 15,750 sweeps per second in 60 "frames" of 262 ½ lines each.

The computer's video circuitry has quite a job feeding information to the raster display. It goes something like this: Send out a synchronization pulse to start the beam on the very top line of the screen; wait until the beam sweeps far enough into the screen to be easily viewed; get the first row of characters to be output; output a sequence of dots representing the top line of that first row of characters; when the end of the line is reached, wait until the electron beam retraces to the beginning of the line; output a second row of dots; continue the process until the first line of characters is completely drawn; get the next line of characters; repeat the whole process until

When You Opt For **M D** MICRO DESIGN You Get All The Options

INTERFACE EXPANSION SYSTEMS FOR THE TRS-80* COMPUTERS

The MDX Series Interface Expansion Boards provide a wide range of features for the TRS-80* Computers. Fully assembled units offer immediate, inexpensive expansion; or choose the bare or partially assembled units for even more savings. Since assembly of the board in sections is possible, you can build in the features you need, as you need them! P.C. Boards are solder-masked and silkscreened for easy assembly; each comes with the illustrated *User's Manual*.

TRS-80* Model I EXPANSION ✓76

Our MDX-1 and MDX-2 Interface Expansion Boards are field tested/field proven and offer more options for the Model I than any on the market. Also compatible with the PMC-80 and LNW-80 Computers. Custom Case Available for MDX-2.

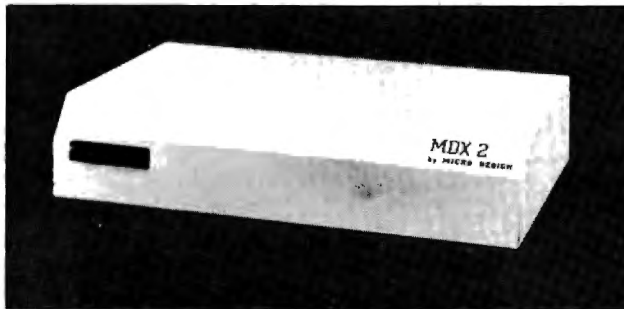

FEATURES:

- MEMORY EXPANSION to 48K
- ON-BOARD SUPPLY, fully protected
- PHONE MODEM, 0-600 baud, direct connect, "answer" and "originate" modes
- REAL TIME CLOCK, software programmable
- PARALLEL PRINTER PORT
- SERIAL PORT—RS232 and 20ma loop compatible
- EPROM OPTION for user firmware
- DUAL CASSETTE LINE
- FLOPPY DISK CONTROLLER: The MDX-2 has all the features of the MDX-1 plus Floppy Disk Controller. The Controller is compatible with any single or double-sided floppy disk drive that is configured for use with the TRS-80 computer.

MDX-1 MDX-2

✓	✓
✓	✓
✓	✓
✓	✓
✓	✓
✓	✓
✓	✓
✓	✓
✓	✓

ALL MDX SERIES BOARDS ARE WARRANTED AND SERVICE IS AVAILABLE.

TRS-80* Model III EXPANSION ✓77

The MDX-3 Interface Expansion Board is designed to mount inside the Model III Computer. Connectors provide external access to the Floppy Disk Controller (for external drives) and RS232 port.

FEATURES:

- DOUBLE-DENSITY FLOPPY DISK CONTROLLER—1.8 times the normal single density storage; digital data separation; controls up to 4 drives.
- SERIAL PORT—RS232 and 20ma loop compatible, 110-19,200 baud
- PHONE MODEM—0-600 baud—direct connect—"answer" and "originate" modes.
- FULLY COMPATIBLE with all Model III software.

MDX-5: Also for the TRS-80* Model III

For the user who already has disk we offer the MDX-5. This board mounts next to the Floppy Disk Controller Board in the Model III.

FEATURES:

- SERIAL PORT—RS232 and 20ma loop compatible, 110-19,200 baud
- PHONE MODEM—0-600 baud—direct connect—"answer" and "originate" modes.
- Fully compatible with all Model III Software

PHONE MODEM ✓78

The MDX-4 Phone Modem utilizes the same Direct Connect, 0-600 baud design as used in the other MDX series boards and: answer/originate modes; solder-masked & silkscreened; on-board power supply. Compatible with any RS232 port.

*TRS-80 is a trademark of Tandy Corporation.



For a free brochure contact:

Our Expensive Expansions Are Not Cheap, They Are Inexpensive.

	MDX-1	MDX-2	MDX-3	MDX-4	MDX-5
Bare P.C. Board & User's Manual	\$69.95	\$ 74.95	\$ 74.95	\$29.95	\$ 59.95
Fully Assembled		\$309.95	\$324.95	N/A	\$259.95
Partially assembled		\$299.95	\$199.95	N/A	\$159.95
Custom case		\$ 42.95			
Any manual ordered separately, \$5.95 plus \$3.00 postage & handling.					
All board orders, add \$5.00 for postage & handling. (Texas residents add 5% tax.)					



OUR BUSINESS IS EXPANDING
EXPAND WITH US



P.O. Box 748
Manchaca, TX 78652

Dealer inquiries welcomed.

• Try Our Hotline (512) 282-0225

THE EXCLUSIVE ORACLE

all lines of characters are drawn; wait until the beam reaches the top of the screen; start again.

This process is complicated enough; but don't forget that, depending on the system, the central processing unit (CPU) may also have to jump into the act in order to change the stuff going out to the screen, or to find what is there. It is this need to produce complicated combinations of signals—vertical and horizontal electron beam synchronization (sync); patterns of dots at the proper signal levels (video); avoiding use of the screen when the electron beam is in the borders (blanking)—that makes computer video display hardware extensive.

The job of video display software, the so-called video drivers, is to provide characters to the video display hardware. When a value is provided for display, the video driver interprets whether the value represents a displayable character or control information (backspace, tab, line feed,

and separate circuitry to mix all the color and dot information together.

Enter the Color Computer. Some folks call it a toy computer. But if it is such a toy, how come it has a full display system, plus eight colors, plus five modes of graphics resolution? And, aside from stealing some memory from program use, how come it needs only two integrated circuits for the whole job? And how come it costs under \$400?

The reason is an ingenious and relatively inexpensive device called a Video Display Generator (VDG). Given the proper input, this single integrated circuit can produce 16 lines of 32 characters per line in either of two pairs of colors, and in normal or reverse lettering, from a 64-character ASCII set; 16 graphics characters in eight colors; point graphics from coarse (64 by 64) in eight colors to fine (256 by 192) in two colors; and certain hybrid combinations of graphics and alphanumerics. When interfaced to a companion Syn-

them to be. Thus, unless your text editor or assembler or whatever allows a user patch to this special software driver, the 32 characters per line is understood as the limit.

So, is there any solution to this problem? Yes, but it is not an easy one. The current Video Display Generator (type 6847) can be combined, through fairly complex logic, with another member of Motorola's 68XX family: The 6845 CRT Controller. This device is capable of producing up to 256 characters per line and 128 lines per screen in any combination. It has separate screen synchronization, independently controlled cursor input and display, and even a light pen input. However, it is not intended to interface with the 6883 SAM chip in the Color Computer, and it cannot produce a color display. It has no built-in graphics. Furthermore, it would need sophisticated video driver software to control scrolling and a complete reassignment of memory space (since the current character screen memory is only 512 bytes). That means an extensive software patch or a separate version of the Color Basic ROM. If you are curious about how complicated this kind of patching can be, try using the LNW-80 computer's 80-character-per-line mode with your own software.

Sure, it can be done. As a matter of fact, one engineer is working on a cartridge plug-in with 80 by 24 video for use with a black-and-white monitor, to run in conjunction with standard Flex displays. But the normal display is lost, along with graphics and color. All the difficulties I mentioned turn up; compatibility is lost.

Is it worth it? Perhaps it is, but before I get a boxful of requests to design one for this publication, let me mention some other considerations beyond the hardware complexity. The primary one is simple: Can you read more than 32 characters on the video display, especially if you are using a color television? There is a characteristic known as bandwidth that affects every video display system. Simply stated, it is the monitor's ability to turn the electron beam on and off quickly and cleanly enough, so that letters do not smear into each other.

Maybe "it's a Sony," but unless your color television was made for tv studio use, its bandwidth is about four MHz. Four MHz... what does that mean? It means that the television can't do anything faster than four million times per second, whatever that anything is. Fast as it sounds, it is still fairly slow. Turn back to the electron beam sweep that I mentioned earlier; it sweeps horizontally at 15,750 times per

“. . . its design must have been determined by some digital deity way back during the misty genesis of computer technology.”

carriage return and so on). The value is then converted to a new value or set of values appropriate for display, and the driver passes that information along. Most personal computer systems use a block of memory to store these character values, and they can move the characters (represented as ordinary bytes of information) around in memory for such things as Basic Print, Print@, Print Tab, tab, backspace, scrolling, and so forth.

Once the values are stored in video memory (also called video refresh memory), the video display hardware then takes over; it extracts these bytes as needed and feeds them to a character generator. The character generator produces the horizontal dot patterns for each row of the display screen, as requested by a video countdown chain. These dot patterns are then fed to a shift register, which feeds the dots one at a time to the video display through output circuitry.

Notice how I have avoided the question of color. If you think black-and-white display as I've described it sounds complicated, then the composite video needed for color production is a nightmare. It often requires its own color memory block

chronous Address Multiplexer (SAM)—as it is in the Color Computer—several mixed alpha/graphic modes can be produced.

For this flexibility and economy, certain sacrifices are made. The character set, being an internal one, is fixed at the basic 64 uppercase ASCII letters, numbers and symbols. Only by tacking on additional hardware (an option allowed in the VDG design) can up to 256 characters of any type be selected. See "80 Applications," November 1981, for details on external character generation for the Color Computer.

The other sacrifice is those long lines of characters; the VDG is fixed at 32 per line; the reasons are explained later on. Since this device ties in so closely with the other Color Computer hardware, a virtually complete remake of the computer system would be necessary to achieve 64 or 80-character lines. Anywhere from 24 to 50 characters per line can be produced in software (using the high-resolution mode), but this method sacrifices about 8,000 bytes of memory. It also suffers from the same drawback that all piggyback software drivers do: They can only be invoked if the software in use allows

second. Okay, four million somethings divided by 15,750 sweeps is 254. The television can display 254 somethings per screen line; that's it. Now 254 is conveniently close to what the Color Computer actually displays—256 clear dots per screen line.

Unless you are willing to add video output to your Color Computer, and use it on a fast black-and-white monitor or buy a \$1,000 (or more) color monitor, then looking for more than the built-in 256 dots per line is futile. As I said, it can be done. The Ohio Scientific C4P has a 64-character color display; but it doesn't use an RF modulator for television input. Instead, it requires a color monitor, and even then the screen is wearying to read.

If I sound discouraging about that one point, it is because I view the Color Computer as a coherent, solid package—designed well and with considerable consideration toward expansion. It has twice the power and speed at half the price of a Model III. Until (if?) the rumored BBC/ Acorn computer hits our shores from England, Radio Shack's Color Computer and Commodore's VIC will probably repre-

sent the forefront of inexpensive personal computer capability.

Which brings me to another mailbox-filling item. *80 Microcomputing's* publisher Wayne Green said in the January "Remarks" that he thinks the Color Computer is a bust, and Radio Shack is going to phase it out. Well, here's hoping Wayne was talking to the wrong people, and Radio Shack realizes that, like the Model I, it's already created another standard in personal computing. I am not about to tell Radio Shack how to run its business—after all, there aren't 8,000 Dennis Kitsz stores across the world—but you know what I think? I think the Color Computer wipes even the legendary Apple right off the technological map. Challenges invited. Keep those electronic coloring books coming, Fort Worth.

Updates

Readers continue to ask about the Model I lowercase modification suggested in this column (December 1981). In some units there may be problems because of an apparent manufacturing flaw in the unused gate of Z25. To avoid prob-

lems, piggyback another 74LS32 atop Z25, soldering pins 7 and 14 to the chip below. Route the rest of the wires as described.

Please note: A self-addressed, stamped envelope is required for personal replies. This is a kind of desperation column, so please write to an author or manufacturer first with your question. That goes double if you are trying to get something like FWAPBAT/CMD together with BUMDOS 9.46 to run a Quiver-II printer. Insist that dealers and manufacturers support their products fully with good manuals, schematics, explanations and troubleshooting. I've been pushing for published source codes from the beginning. Oh yes... Radio Shack seems to have straightened out the customer service mess and is doing a good job these days, so don't hesitate to try their toll-free number with questions.

I often refer to earlier articles, updates, and columns in *80 Microcomputing*, and occasionally to other publications. You may obtain an annotated bibliography by sending a self-addressed, stamped envelope to me: Dennis Kitsz, Roxbury, VT 05669. ■

If you liked MICROPROOF, then you'll love SON OF MICROPROOF:

ELECTRIC WEBSTER™

The ultimate spelling checker.

EASY TO USE:

Enter the appropriate command, and ELECTRIC WEBSTER proofreads your document, displaying misspellings and typos on the screen. Then correcting ELECTRIC WEBSTER can display each error separately, requesting you to enter the correct spelling for each. You are also given the option of displaying errors in context or adding words to ELECTRIC WEBSTER's 50,000 word vocabulary. If you do not know the correct spelling you may also ask ELECTRIC WEBSTER to look it up for you. Finally, ELECTRIC WEBSTER corrects your document. All in less than a minute.

LOW PRICES:

Standard MICROPROOF is available on TRS-80 Model I or II for \$69.50. Standard ELECTRIC WEBSTER is available for either \$89.50 (TRS-80 Model I or III, Apple) or \$149.50 (CP/M, TRS-80 Model II and all others). The optional correcting feature can be added at any time for an additional \$60. Correction feature can be ordered with a patch to operate directly from your word processing software. For each patch, optional Grammatical Checking feature, or optional Hyphenation feature, add \$35.

SELECT APPROPRIATE RESPONSE

CORRECT MISPELLED WORD	ENTER CORRECT WORD
LEAVE WORD AS IS	HIT ENTER KEY
DISPLAY WORD IN CONTEXT	?
DISPLAY DICTIONARY	@
ADD WORD TO DICTIONARY	.
EXIT	!
WORD	(Your error)
RESPONSE	

WHAT THE EXPERTS SAY:

"MICROPROOF" should be obtained by anyone who uses a word processor"
M. Tannenbaum, CPA, *80 Microcomputing*, 8-81

"One word—Excellent."
Program Previews, Computronics, 9-81

"In a comparative review... MICROPROOF was found to be faster than all the others"
P. Lemmons, *BYTE Magazine*, 11-81

"Any person able to use a word processing program can master it in moments."
F. Defler, *Info-World*, 1-82

IMPROVED:

- One-step proofing and correcting.
- Lists errors to screen or printer.
- Can display errors in context.
- Can display dictionary to locate correct spellings.
- New precise symbolic dictionary will not miss an error.
- Remarkably compact (50,000 word dictionary will fit on one 5-inch disk).
- Even FASTER than MICROPROOF (formerly the fastest available).
- Simple Grammatical Checking (Optional Feature).
- Hyphenates automatically (Optional Feature available for some Word Processing programs).

See your local microcomputer dealer or write to:



**CORNUCOPIA
SOFTWARE**

Post Office Box 5028
Walnut Creek, California 94596
(415) 524-8098

45

Notes from BENEATH the KEYBOARD

by Paul Wiener

MULTIDOS is Vernon Hester's new disk operating system for the TRS-80 Model I. A Model III version was to have been released in January, 1982. MULTIDOS is available from the Cosmopolitan Electronics Corp., P.O. Box 234, Plymouth, MI, 48170.

Vernon Hester is the author of the Basic debugging package Boss, and an earlier DOS called ULTRADOS. If you are familiar with Hester's earlier software, you probably expect MULTIDOS to be a well thought out, compact DOS, with a superior Disk Basic. You won't be disappointed.

Many programmers excel in a particular aspect of their work. For example, Kim Watt, author of Super Utility, is known for his disk I/O routines. Charlie Heath, creator of Instant Software's Life and Master Reversi programs, shines at optimizing code to perform with incredible speed. Hester's thing is compression. He jams so much programming into so few bytes you might suspect the RAM chips were put through a compacter. MULTIDOS, and especially its new SuperBasic, are the most outstanding examples of Hester's talent to date.

Two keynotes characterize MULTIDOS: interDOS-compatibility and super-efficient Disk Basic. Compatibility with other DOSs was one of Hester's major design goals. He was successful. MULTIDOS is capable of reading and writing files on TRSDOS, NEWDOS 2.1, VTOS, DBLDOS, ULTRADOS, DOSPLUS, NEWDOS80 and LDOS disks, in single and double densities.

With a single drive double density system, you can boot a single density MULTIDOS system disk and get a directory. Then remove the MULTIDOS disk, insert a double density DOSPLUS disk and get a directory of that too. If you have a four-drive system, you can keep a MULTIDOS disk in drive zero. DOSPLUS in drive 1, NEWDOS in drive 2 and LDOS in drive 3. Make this your permanent working configuration and you will rarely encounter compatibility difficulties. Model I MULTIDOS can also read and write disks from several Model III operating systems, but not Mod III TRSDOS.

MULTIDOS's omni-compatibility does have a few limitations. Before, when I said you could put an alien disk in drive zero to



get a directory I did not mean to imply that MULTIDOS is generally drive zero swappable with other DOS's. That only works for DIRs and single-drive copies.

Also, I have had occasional Load File Format errors when trying to load some alien /CMD files. Other than using the original DOS to load the problem file, then booting MULTIDOS and dumping the program, I have not yet found a way to beat the problem.

MULTIDOS, when used with the MicroProof spelling correction program, may have occasionally truncated some of my SCRIPSIT files. But there are so many different factors that I cannot be sure who the culprit is. It might even be (ahem, ahem) me.

Disk Basic Review

Perhaps you are wondering what is so special about MULTIDOS Disk Basic. To give you an idea, let's review a few general facts about TRS-80 Basics. If you turn on a 48K Model I TRS-80, go into Level II Basic and enter ? MEM. you will find you have 48340 bytes free. In Disk Basic, there is noticeably less user memory available because the DOS itself takes up room, and Disk Basic offers several code consuming enhancements such as hex and octal to decimal conversions and user defined functions.

Radio Shack Disk Basic 2.2 running under TRSDOS 2.3 offers 38290 bytes free (with no high memory reserved and a default of three file buffers allocated). NEWDOS 2.1 Disk Basic has 38659 bytes available. This 369 byte improvement is more

impressive when you consider the fact that Apparat achieved this while adding several new Basic features, such as renumbering and single-key editing commands. Their NEWDOS80 (version 1) Basic is back down to only 38263 free bytes, but many new enhancements have been added. LDOS 5.0 LBASIC has only 34913 bytes available. This is, in part, due to some Basic enhancements, but I believe most of the extra memory is being used by its very comprehensive operating system.

Some DOSs have more than one Basic allowing the user to choose between features and memory. Micro Systems Software's DOSPLUS has two Basics—a feature packed one and a stripped down (T for Tiny) TBASIC. The full-sized Basic gives you 37448 free bytes and the tiny one a whopping 40051. However, it would be deceptive to compare these figures to the others because DOSPLUS Basics come up with a default of zero files reserved, instead of three, as do the others. Entering DOSPLUS Basic with three files reserved leaves 35810 bytes free. Reserving three files for TBASIC leaves 38413 free. TBASIC, when compared on an equal footing to NEWDOS 2.1 Basic, loses out by 246 bytes.

Vernon Hester's earlier operating system, ULTRADOS, has three different Basics. In size and luxury, they run the gamut from motorbike to limousine.

Super Basic

Now along comes MULTIDOS with its SuperBasic. SuperBasic is more feature packed than any of the other Basics men-

6 ways to give your TRS-80* a

+PLUS

Exhaustive research and professional standards bring you the best in business software.

EASYTRAK™

KEEP YOUR SALES CURVING UPWARD WITH EASYTRAK™, a powerful, all-purpose activity tracking system. User-specified options enable you to monitor sales activity by territory, product line, salesman, or by combinations. Can monitor inquiries, sales calls and order booking. Production activity (by shift, by product, by day, by team, etc.), spending or income activity are simple to set up with EASYTRAK™. Extensive video displays make available individual, group or total summaries, relative averages, and percentage data all at the touch of a button. Use of an 80-column printer is optional.



MODEL I/III \$125
MODEL II \$150

+ ACCOUNTS RECEIVABLE

PUT MORE CASH IN YOUR BANK ACCOUNT

with +Account Receivable's many collection, credit features, including average payment days, aging schedule and statements. Open-item system records sales activity this year and last, optional automatic discounts and salesman assignment. Cash receipts and A/R adjustments feature extensive on-line validation. And, yes, +Accounts Receivable handles the pesky new 9-digit zip code. Other optional features include service charges to selective customers; partial and on-account payments. Posts, at your option, to +General Ledger.



MODEL III \$325
MODEL II \$350

+ACCOUNTS PAYABLE

FUNNEL THAT STACK OF BILLS into +Accounts Payable system and create an orderly, manageable flow of vendor histories, cash requirements forecasts, check registers and checks, aging schedules, etc. Will accept manual checks, reversals, and adjustments. Pay by selected vendor, invoice, due date, discount dates, and optionally post directly to your +General Ledger. Supports 5-digit vendor numbers.

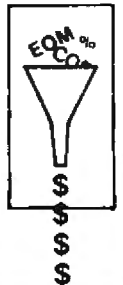

MODEL III \$325
MODEL II \$350

+ GENERAL LEDGER

SLICE OUT MORE PROFIT by using +General Ledger to monitor your financial status. Features include fully-flexible financial statements, both budget and last year comparisons, special report options, monthly and quarterly trial balances, manual and/or automatic journal entries all with extensive audit trails. You structure the chart of accounts with up to 5 digit account numbers.

MODEL III \$325
MODEL II \$350



+ FIXED ASSETS

A POWERFUL SET OF TOOLS TO CALCULATE and monitor fixed asset expenditures, book and tax depreciation, investment tax credit, etc. Will even forecast future depreciation for you. (Handy at budget time!) Code structure enables you to classify assets by departments, buildings, groups or other categories. Handles seven depreciation methods. Can post to +General Ledger for you.

MODEL III \$325
MODEL II \$350



+ PAYROLL

KEEP YOUR EMPLOYEES HAPPY and smiling with prompt, accurate and professional payroll records. Will handle weekly, biweekly, semimonthly, monthly payrolls.



produce checks, check registers, labor reports, earnings reports, Form 941's, W2's, etc. Can handle fixed voluntary deductions, hourly salary employees, bonuses, city and state taxes, etc. Easy to use and update tax tables. Automatic +General Ledger posting.

MODEL III \$325
MODEL II \$350

SPECIAL! All of the above: MODEL III \$1600. MODEL II \$1750.

+PLUS SOFTWARE comes to you feature-packed from on-line validation + machine-language file handling. Extensive documentation and thorough installation guide accompany each order. All systems are furnished on disc. Source code is included.



+PLUS

PLUS COMPUTER TECHNOLOGY, INC.
6900 N. AUSTIN AVENUE
CHICAGO, IL 60648 (312) 647-0988

Dealer inquiries invited

TRS-80 is a registered trademark of Tandy Corp
EASYTRAK is a trademark of Plus Computer Tech Inc

Notes from BENEATH the KEYBOARD

tioned. SuperBasic has all the normal Disk Basic commands present in Radio Shack Disk Basic, plus the following:

CMD C compresses a program by removing linefeeds and spaces. This is a minimal compression utility. It does not remove REMARK statements but is fairly intelligent. It does not compress text in quotes or data statements.

CMD K lets you instantly zero an array.

CMD L lets you delete an array and regain the memory previously allocated to it. If you desire, the array can then be redimensioned.

CMD M lets you move a line from one part of a Basic program to another. For instance, **CMD M**, 50,2000 copies line 50 to line 2000 and then deletes line 50.

CMD N works like **CMD M** except the original line is not deleted after being moved. Thus, **CMD N** lets you duplicate lines of code. **CMDs M** and **N** are handy because SuperBasic's renumbering feature will not allow you to move lines out of sequence. My complaint is that they only work on one line at a time. If you want to move or copy blocks of code, you have to do so line by line.

CMD O lets you allocate an additional file buffer. If you did not reserve enough files when you entered Basic, you do not have to go down to DOS and start again. Just enter **CMD O** and keep right on going. Like the other **CMD** functions, this can be executed under program control; so if you like, your program can allocate itself files as it needs them.

CMD Q invokes a fast machine language string sort. You can sort a one- or two-dimensional array. If the array is two-dimensional, you have to designate which array column is to be used as the key field. The sort can be ascending or descending, and you can specify that only part of an array is to be sorted.

A sort is a handy feature to have built into Basic, but I wish MULTIDOS's were not limited to just strings. This constraint has two disadvantages. If you want to sort numeric data, you have to first convert it all to strings via the **STR\$()** function. Then, if you want to do arithmetic with the sorted values, they have to be reconverted to numbers with **VAL()**. All this can be very time consuming. Secondly, string sorts, which are alphabetical, often yield results inappropriate to numbers. For instance, in an ascending alphabetical sort, the word zoo comes after the word aardvark because aardvark comes first in alphabetical order. This is valid despite the fact that aardvark is longer than zoo. But when the same logic is applied to strings which look like numbers, 95 is sorted out as being higher than 100, simply because 9 is the first character of 95, is greater than 1, the

first character of 100. However, I believe most, or all, TRS-80 Mod I DOSs which offer sorts with their Basics restrict themselves to string sorts.

CMD V prints out a list of all your program's currently assigned variables and their values. This is not to be confused with the normal cross-reference feature dating back to NEWDOS 2.1. The latter prints out the line numbers which refer to specified variables or line numbers (or all variables and line numbers), but gives no indication of the values assigned to those variables. In addition to **CMD V**, SuperBasic has the standard cross-reference feature accessed through the semi-colon(;).

CMD X is an unusual feature. The only other DOS I know of with this feature is Hester's other creation, ULTRADOS. It works in conjunction with the Basic # method of entering SuperBasic. These two commands allow you to shuttle back and forth between Disk Basic and Level II. Their purpose is to allow the convenience of SuperBasic while developing and debugging programs intended to run in Level II.

CMD command has been in most DOSs since NEWDOS 2.1. With it you can execute any machine language program, or DOS library command, directly from Basic. MULTIDOS's version of **CMD** command is much better than the early NEWDOS 2.1. The desired command is executed immediately—the pause before and after has been dispensed with. And not as much memory is required, so your attempt is less likely to be thwarted by an out of memory message.

MULTIDOS's **CMD** command even lets you nest Basic within itself. If you enter **CMD Basic**, Basic will then reload *within* itself. You can then write, load, save and execute programs as usual. If you enter **CMD S**, instead of going back to DOS, you return to the previous level of Basic with its variables, For . . . Next and GOSUB . . . Return stacks intact! You can write a program which recursively loads another level of Basic, reloads itself into that level of Basic, and repeats until there is no more memory left. There must be a practical application for that capability somewhere, but I haven't come up with one yet.

To enter SuperBasic from DOS, you use the syntax which has been standard since NEWDOS 2.1. You are not prompted with the Memory Size? and How Many Files? questions. Simply typing Basic will bring up SuperBasic without any memory being reserved, and defaulting to three disk file buffers allocated. To reserve memory, files or both, specify your desire in the Basic invocation line. You can also append a

Basic command to the line. For example,

```
BASIC 5,55000, RUN "STAMPER/BAS
```

loads Basic reserving memory starting at 55000 decimal and allocates five disk file buffers. Once Basic is in control, the program STAMPER/BAS is automatically loaded and executed.

MULTIDOS also follows the NEWDOS 2.1 standard by allowing you to use Basic * to reenter Basic and recover the Basic program in memory before Basic was last exited. MULTIDOS however, surpasses the NEWDOS standard with its Basic!. Basic! is similar to Basic * except the former recovers programs left in memory by alien Basics. If you have difficulty loading an alien Basic program into SuperBasic, you can boot its home DOS with its version of Basic, load the program and reboot MULTIDOS. Then enter Basic! and a few seconds later you'll be in SuperBasic with the program still in memory. Then you can resave the program and SuperBasic should be able to reload it at will. And as I mentioned before, Basic # lets you recover a program left in memory by Level II.

SuperBasic supports the short hand introduced by NEWDOS Basic, namely ".," for list the current line, "," for edit the current line, up-arrow for list the previous line, down-arrow for list the next line, shift up-arrow for list the first line, shift down-arrow for list the last line, L for List, W for Edit and D for Delete.

In addition, SuperBasic adds "!" for list the last Break-in line, P for list a page of text, C for Continue, and R for Run. I think the most significant of these is P which gives SuperBasic page-scrolling capability. The only other Basic I know of with this feature is NEWDOS80.

SuperBasic has introduced a minor change from prior Disk Basics. The H can be dropped from the syntax for hex to decimal conversions. To convert 2FAD hex to decimal, type either ?&H2FAD or just ?&2FAD.

SuperBasic has advanced editing commands. Fstring will search your program for every occurrence of "string" and list the line numbers it is found in. If "string" occurs more than once in any line, you will be told how many times it was present in that line.

A Multi-Talented Global Editor

Pressing "-" (minus) and then Enter will invoke an intelligent global editor (GE). There are a great many things the GE allows you to do. Suppose you have the variables A, X, AX, and XF in your program and the program contains the line,

```
510 W$ = "AX"
```

QUALITY SOFTWARE FOR TRS-80 COLOR!



ADVENTURES!!!!

For TRS-80, and COLOR-80. These Adventures are written in BASIC, are full featured, fast action, full plotted adventures that take 30-50 hours to play. (Adventures are inter-active fantasies. It's like reading a book except that you are the main character as you give the computer commands like "Look in the Coffin" and "Light the torch.")

Adventures require 16K on COLOR-80 and TRS-80. They sell for \$14.95 each.

ESCAPE FROM MARS

(by Rodger Olsen)

This ADVENTURE takes place on the RED PLANET. You'll have to explore a Martian city and deal with possibly hostile aliens to survive this one. A good first adventure.

PYRAMID (by Rodger Olsen)

This is our most challenging ADVENTURE. It is a treasure hunt in a pyramid full of problems. Exciting and tough!

TREK ADVENTURE (by Bob Retelle)

This one takes place aboard a familiar starship. The crew has left for good reasons - but they forgot to take you, and now you are in deep trouble.

DEATH SHIP (by Rodger Olsen)

Our first and original ADVENTURE, this one takes place aboard a cruise ship - but it ain't the Love Boat.

VAMPIRE CASTLE (by Mike Bassman)
This is a contest between you and old Drac - and it's getting a little dark outside. \$14.95 each.

SPACE SHUTTLE

ONE OR TWO PLAYER HIGH RES GAME -
Your mission is to dock with an orbiting space platform - but you may have to land on the planetary surface for refueling first. A real value in a high res real time game. \$6.95.

KILLERBOT - (Available in 4K) - Real time action at 20 levels of difficulty as you run, sneak, and dodge your way through a bloody field of Killer Robots. Get across or die! Joysticks or Keyboard controls. TRS-80 COLOR (ANY BASIC 4K or more.). \$9.95.

SLASHBALL (Available in 4K) - This one is best described as a thinkers arcade game. It rewards fast reflexes and clear thinking - like nothing you have ever seen before. It is one of our best family games for one or two players. \$9.95.

TIMTREK - A REAL TIME, REAL GRAPHICS STARTRECK. See your torpedoes hit and watch your instruments work in real time. No more unrealistic scrolling displays! \$14.95.

STARFIGHTER - This one man space war game pits you against spacecruisers, battlewagons, and one man fighters, you have the view from your cockpit window, a real time working instrument panel, and your wits. Another real time goody. \$9.95

BATTLEFLEET - This grown up version of Battleship is the toughest thinking game available on OSI or 80 computers. There is no luck involved as you seek out the computers hidden fleet. A topographical toughie. \$9.95

LABYRINTH - 16K EXTENDED COLOR BASIC - With amazing 3D graphics, you fight your way through a maze facing real time monsters. The graphics are real enough to cause claustrophobia. The most realistic game that I have ever seen on either system. \$14.95.

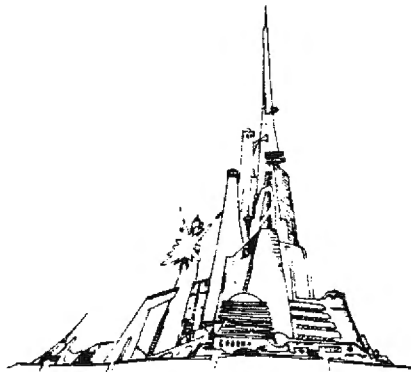

QUEST - A NEW IDEA IN ADVENTURE GAMES! Different from all the others, Quest is played on a computer generated map of Alesia. Your job is to gather men and supplies by combat, bargaining, exploration of ruins and temples and outright banditry. When your force is strong enough, you attack the Citadel of Moorlock in a life or death battle to the finish. Playable in 2 to 5 hours, this one is different every time. 16K COLOR-80 OR TRS-80 ONLY \$14.95.



SPACE ZAPPER - Protect your central Star Base from ships that attack from all four sides. Fast reflexes are required as the action speeds up. Great for kids or Dads. This game has high speed high resolution graphics and looks as if it just stepped out of the arcades. - 16K extended or 32K disk. BASIC TRS-80 Color only. \$14.95.

Please specify system on all orders

This is only a partial listing of what we have to offer. We have arcade and thinking games, utilities and business programs for the OS1 and TRS-80 Color. We add new programs every week. Send \$1.00 for our complete catalog.



TRS 80

**2352 S. Commerce, Walled Lake, MI 48088
(313) 669-3110**

TRS 80 COLOR

✓107

Notes from BENEATH the KEYBOARD

You could tell the global editor to change all occurrences of X to Y, but only where it occurred in a single-letter variable. The variable X would be replaced with Y in your text, while the variables AX and XF would be left alone. The word AX would also be unchanged.

You can tell GE to only alter the left-most character of multicharacter variables. In this case, changing X to Y would replace all the XF's with YF's without altering the X's or AX's. Likewise, you could change only the second letter of multicharacter variables. Or you might alter only quoted text. Then the line 510 would become

```
510 W$ = "AY"
```

and everything else would be left alone.

The GE will also globally edit reserved words. You can change Prints to LPRINTS or remove all Stops. The GE also can change CHR\$() statements to statements with space-saving compressed graphic-strings. This is true whenever the CHR\$() represents graphic or space-compression characters. MULTIDOS also lets you type compressed graphics directly in from the keyboard. Once compressed graphics have been entered into a program, instead of generating garbaly listings as in other Basics, they will list looking just like the graphics they represent. Lines containing graphics can be edited in the normal manner. In combination, these features simplify the design of Christopherson-like graphics.

Meanwhile, back at the GE, there is still more it can do, like by allowing you to merge or split Basic program lines. With

all GE operations you can restrict the operation by specifying a range of line numbers.

My only reservation about the GE is its complexity. There are many specifiers and special delimiter characters to remember. To specify the variable AX as the target, you simply enter AX (no delimiters). To change only variables which start with X, you must enter X' (a single quote to the right of the X and none to the left). To change Xs only, without affecting any multicharacter variables, you enter 'X'. And to change the keyword TO, you surround it as follows: <TO>. To change CHR\$() statements representing graphics to compressed strings, you enter + (a plus sign) as the editing target. If the CHR\$() expressions you want to convert represent string compression codes, you enter * (asterisk) as the target.

To merge Basic lines, you use a / (slash) followed by a line number. To split a line, you use a - (minus sign) followed by the text at the split point of the target line. My feeling is that while the GE is a valuable Basic utility, it will take a lot of getting used to before it can be used comfortably without referring to the documentation.

Renumbering and Name Commands

Like most other Disk Basics, SuperBasic has a line renumbering facility. You access it by typing ":" (colon). Entering just ":" merely checks for errors; entering ":" followed by four parameters invokes the actual renumbering function. The parameters are the first new line number, the new increment, the lowest old line number to be altered and the last old line number

to be altered. All line numbers outside the specified range are left alone.

Renumber's inability to move blocks of code is only partly compensated for by the CMD M and N functions. SuperBasic's renumber does, however, have another capability, which, so far as I know, is not available in other Disk Basics. You use it to recover from a New command. Renumber the program not there by typing ":" and—presto, now you don't see it, now you do—your program is back and can be listed, edited, run and saved. SuperBasic's renumber can renumber programs containing a line numbered zero (0), and programs with compressed graphics.

The Name command lets you load and run a program without re-initializing the variables set by a previous program. You can follow Name with either a filename or a string variable containing a file name. Using Name under program control allows true Basic chaining.

SuperBasic does not have the various special file modes of NEWDOS80. It does incorporate NEWDOS 2.1's old trick of allowing you to add data to the end of an existing sequential file via the Open E option. And, as stated earlier, SuperBasic supports variable record length files. Other than that, its sequential and random I/O is pretty standard. Yet all things considered, SuperBasic is more feature packed than any other DOS Basic.

So, how much memory has Hester left us with after adding all the special features? 40033 bytes with three files reserved—or doing it the DOSPLUS way, 40900 with no files reserved. SuperBasic

OMNITERM

What is OMNITERM?

OMNITERM is a professional communications package for the TRS-80 that allows you to easily communicate and transfer files or programs with almost any other computer. We've never found a computer that OMNITERM can't work with. It's a complete package because it includes not only the terminal program itself, but also conversion utilities, a text editor, special configuration files, serious documentation and serious support.

Why do I need it?

You need OMNITERM if you need to communicate efficiently with many different computers, or if you want to customize your TRS-80 for use with one particular computer. You need OMNITERM to SOLVE your communications problems once and for all.

What do I get?

The OMNITERM package includes the OMNITERM terminal program, four conversion utilities, a text editor, and setting files for use with popular computers such as CompuServe, the Source, and Dow Jones — just as samples of what you can

The ULTIMATE TRS-80 Terminal Package

do for the computer you want to work with. The package includes six programs, seven data files, and real documentation: a 76-page manual that has been called "the best in the industry." And OMNITERM comes with real user support. We can be reached via CompuServe. Source, phone, or mail to promptly answer your questions about using OMNITERM.

What do I need to use OMNITERM?

A Model I or Model III TRS-80, at least 32K of memory, one disk, and the RS-232 interface, or Microconnection modem. OMNITERM works with all ROMs and DOSes, and will work with your special keyboard drivers.

What will it do?

OMNITERM allows you to translate any character going to any device: printer, screen, disk, keyboard, or communications line, giving you complete control and allowing you to redefine the character sets of all devices. It will let you transfer data, and run your printer while connected for a record of everything that happens. OMNITERM can reformat your screen so that 80, 32, or 40 column lines are easy to read and look neat on your TRS-80 screen. It even lets you get on remote computers with just one keystroke! The program lets you send special characters, echo characters, count UART errors, configure your UART, send True Breaks and use lower case. It accepts VIDEOTEX codes, giving you full cursor control. It will even let you review text that has scrolled off the screen! Best of all, OMNITERM will save a special file with all your changes so you

can quickly use OMNITERM for any one of many different computers by loading the proper file. It's easy to use since it's menu driven, and gives you a full status display so you can examine and change everything.

"OMNITERM has my vote as the top TRS-80 terminal program available today" Kilobaud Microcomputing, June 1981, pages 16-19.

OMNITERM is \$95 (plus shipping if COD) Call for 24 hour shipment. Manual alone \$15, applied toward complete package. Visa, M/C, and COD accepted. MA residents add 5% tax. Dealer inquiries invited.

Contact Lindbergh Systems for your custom programming needs. We are expert at writing software to work with YOUR hardware, in assembler, high-level language, or Forth.

Lindbergh Systems

41 Fairhill Road, Holden, MA 01520 (617) 852-0233

Source: TCAB18 CompuServe: J0310267 TRS-80 is a ™ of Tandy Corp

✓ 135

\$275 DISK DRIVES

5 1/4" 40 Track drive with case and power supply.

FLIPPY DRIVES ONLY \$295.00
2 DRIVE CABLE \$14.95
4116 MEMORY CHIPS 8 FOR \$20

CORSAIR COMPUTER CORPORATION

7952 Highway 80 West
 Fort Worth, TX 76116
817-244-8051

IEEE-488 TO TRS-80* INTERFACE

Everything needed to add powerful BASIC GPIB-488 controller capability to TRS-80 Model 1 or 3, Level 2 or DOS with a minimum of 16K.

488-80B
 For Model 1
 Operation



488-80C
 For Model 3
 Operation

Model 488-80B or 488-80C Price: \$375.

* shipping, insurance & tax
WHEN ORDERING SPECIFY DISK OR TAPE
SCIENTIFIC ENGINEERING LABORATORIES

11 Neil Drive • Old Bethpage, NY 11804
 Telephone: (516) 694-3370

*Trademark of Tandy Corp.
 There is no affiliation between Scientific Engineering Laboratories and Tandy Corp. or Radio Shack

We have THE LOWEST PRICES ON TRS-80™

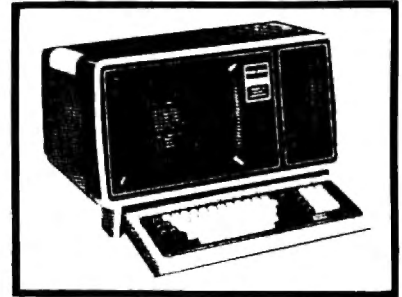

Model II 64K \$ 3298

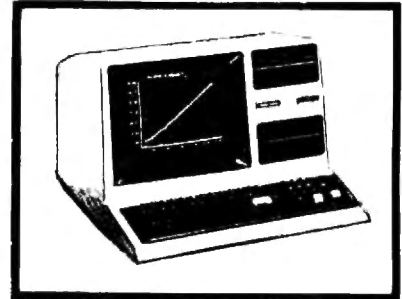

Model III 16K \$839

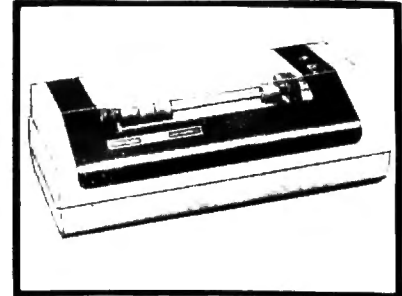

Line Printer VII. \$329

OKIDATA	Microline 80	\$394
	Microline 82	\$499
EPSON MX-70		\$369
EPSON MX-80		\$479

\$ SAVE

MOST ORDERS
 SHIPPED WITHIN
 ONE BUSINESS DAY

VERBATIM DATALIFETM DISKETTES
 5 1/4-inch (box of 10) \$25.95
 8-inch Double-Density, \$43.95

* Payment: Money Order, Cashiers Check, Certified Check, Personal Checks require 3 weeks to clear. VISA, MASTERCARD — Add 3%

WRITE OR CALL FOR OUR COMPLETE PRICE LIST.

CALL (602) 458-2477

— All prices are mail order only —

RAND'S
 2185 E. FRY BLVD.

SIERRA VISTA, AZ 85635
 TRS-80 is a trademark of Tandy Corporation

SOFTWARE THAT FITS

- PROPERTY MANAGEMENT
- INVENTORY MANAGEMENT
- PATIENT DATA MANAGEMENT



MICRO-COMPUTER SALES CORPORATION OF FAYETTEVILLE, NC
 Phone: 919-483-2003
 Post Office Box 53376 • Fayetteville, NC 28305

Verbatim flexible disks

Call Free (800) 235-4137 for prices and information. Dealer inquiries invited. C.O.D. and charge cards accepted.

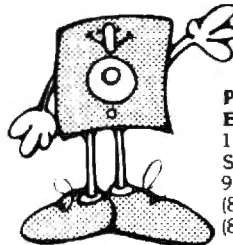

PACIFIC EXCHANGES
 100 Foothill Blvd.
 San Luis Obispo, CA 93401. In Cal. call (800) 592-5935 or (805) 543-1037.

207

80 microcomputing

Back Issues



January 1980.....\$5.00
 February to June 1980.....3.00
 Single back issue
 July 1980 on.....3.50
 Single back issue

Add \$1.00 per magazine for shipping.

10 or more back issues
 add \$7.50 per order for shipping.

Back Issues • Attn. Pauline Johnstone
 80 Pine St. • Peterborough, NH 03458

TRS-80 COMPUTER DISCOUNTS

- Factory Direct
- Best Prices Anywhere
- No Out-of-State Taxes
- Full Radio Shack Warranty
- Free Price List

SCOTT TASSO

Owner
 Radio Shack Associate Store #7053
 175 E North Delsea Drive
 Vineland, N.J. 08360
 800-257-0426
 NJ 609-691-7100

510

Notes from BENEATH the KEYBOARD

is smaller than any other Basic despite all its bells and whistles. Hester truly is the code-compacting champ of TRS-80dom.

There's More

MULTIDOS also comes with a file called BBASIC. The extra B is for Boss—Hester's debugging package. Boss Basic has all the features of SuperBasic, plus its own specialties. In Boss, the "@" key becomes a control key, much as in SCRIP-SIT. It works in conjunction with the keys 1, 2, 3, 4, 5, 6, 7, down-arrow, up-arrow, N and O keys, thus establishing 11 special control functions.

@1 and @2, respectively, turn off and on the trace function. This is not the standard Basic Trace, but a special enhanced Boss version. Instead of filling the screen with line numbers and wreaking havoc with your display, the trace presentation restricts itself to the upper-right edge of the top four screen lines.

The number of the first line executed during a trace is displayed at the end of the top line of the video. The next line number is displayed below that, and so on. The fifth line number will replace the first one on the top line. The trace continues to cycle through those four locations. You can always tell which line number is current, because a ">" (greater than) character acts a pointer.

If it seems this arrangement would make the numbers disappear too rapidly, read on! Boss has several features to ensure you will not miss a single step (a single singlestep?) of your trace.

The DOS Itself

Though Basic is MULTIDOS's specialty, the DOS itself is nothing to sneeze at. It has many practical and unique features, and some special utilities as well. One interesting feature is the Mighty Multi. This is sort of a small scale implementation of the MINI-DOS concept. Mighty Multi allows you to access certain DOS features while running an applications program, provided the program does not interfere with DOS's interrupt processing. Whenever you press ":" and ";" (colon and semicolon) simultaneously, the program running pauses allowing you to execute any of Mighty Multi's functions. When you are through with Mighty Multi, your program resumes as if it had never been interrupted. Mighty Multi does not however, restore the video to the pre-interruption display.

NEWDOS80's MINIDOS, which I believe was the first to appear for the TRS-80, allows you to access almost any DOS function. LDOS 5.1's restricts you to: toggling the clock display on and off; entering DEBUG, FREE, DIR, KILL a file; sending a

top of form to a printer; sending any specified character to a printer; or repeating the last issued DOS command. MULTIDOS' is restricted to only four functions: DIR, Copy a file, Kill a file, or List a file.

Mighty Multi does not have a repeat-last-DOS-command function. One is not really needed since pressing Enter, without any other input, automatically repeats the last DOS command anyway. You can even do a little command editing. Suppose you have just entered the following command:

```
DUMP W2/TST:(START = X'71A5',  
END = X'7AEF',TRA = X'71B0')
```

and you get an Improper File Name message. On closer inspection, you notice you accidentally typed 2W>TST instead of W2/TST. If you are like me, retyping such dump commands gives you headaches. With MULTIDOS you need only retype DUMP W2/

After typing the slash, press Clear and Enter. The entire corrected Dump command will be entered and executed by MULTIDOS.

MULTIDOS has two different screen printing functions: plain old JKL and HJK. JKL sends the contents of the screen to

"Hester's thing is compression."

the printer, translating all graphics characters into dot. But if you are lucky enough to have a printer with the capacity to print TRS-80 graphics, the HJK option sends the graphics as they are.

Other DOS's allow you to preconfigure your system to perform one type of dump or the other. MULTIDOS leaves both options at your finger tips. This would be an advantage for people who frequently switch between the two printers; but for the rest of us it could be a disadvantage, because of the potential for pressing the wrong set of keys.

MULTIDOS is exceptionally fast. Its boot-up sequence, library commands and general disk I/O are all quick.

DOS command lines can contain more than one command. If you enter DIR :1,FREE (note the separation by comma), you first get a directory of drive 1 and then a display of the free space on all your active disk drives. By the way, MULTIDOS is the only DOS I know of whose Free command displays totals of the free space on all your drives as well as for each individual drive. It also totals vacant directory file slots for you.

MULTIDOS prompts you for the date

when you first boot-up. If you don't want to enter MM/DD/YYYY, just hit Enter to bypass the question. If you have already entered the date in a previous MULTIDOS session, and you have not yet powered down and nothing has overwritten MULTIDOS' date storage area, MULTIDOS will remember the date and bypass the date prompt automatically. MULTIDOS also remembers the time through a reset.

It is generally a good idea to enter the date, since MULTIDOS will then automatically include it in the directory entries of files saved during that session. It can be retrieved via the DIR (A) command. This can be helpful in determining which file is the latest version of a program. While MULTIDOS's use of the date is not as comprehensive as LDOS, it is a feature most DOS's do not include at all.

MULTIDOS Library

MULTIDOS has all the library and utility features of TRSDOS and a good many others. I will only outline the ones that make MULTIDOS outstanding. So if you do not see something mentioned here do not assume it is lacking in MULTIDOS; there's just no need to rehash it.

Speaking of hashing, MULTIDOS's Hash command calculates the hash code for any file you specify.

MULTIDOS' Build and Do commands comprise a chaining function. Build allows you to create a preprogrammed series of DOS commands and save them in a file. Later you can execute the file via the Do command. While this is not as sophisticated as LDOS's Job Control Language (JCL), MULTIDOS's ability to nest Do files puts it a step ahead of most other DOSs in the chaining department.

The TOPMEM nnnn command lets you enter an address above where the DOS ain't allowed to mess around. It is similar to answering the Memory Size? question in Basic. You can enter the address in either decimal or hex. If you enter TOPMEM without an address, MULTIDOS will return the address currently protected by TOPMEM.

Clear, zeros all memory between 5200H (the beginning of user, or /CMD file, memory) and TOPMEM. I am not sure what someone would use this for, except possibly as preparation for a project in which, at some stage, memory has to be inspected to see what was altered by the previous stage of the project.

@3 directs the trace to your printer. If you have a printer, this feature is all you will need to ensure you don't ever lose track of a trace because of a clear screen statement in the target program. You can turn the printer trace off or redirect it to the video with the @2, and @1 keys.

Notes from BENEATH the KEYBOARD

@4, @5, @6 and @7 control the Basic singlestep mode. @4 turns singlestep off, @5 turns on the singlestep-by-line mode. In this mode, the target program will pause before starting to execute each program line and wait for you to press a key. This allows you to observe the line number being executed (as revealed by Boss' trace function) and the effect of that program line.

@6 turns on the singlestep-by-statement mode. This is just like its line-by-line equivalent, except the pause occurs before each statement. This allows you to singlestep through multiple statement lines.

@7 sets a mode to provide automatic continuous singlestepping with a user selectable delay. The auto-singlestepping stops either before each line or each statement, as you desire. After a brief pause, the next line or statement is executed. You can slow down the stepping by pressing @ down-arrow. Conversely, you can speed up the trace by holding down @ up-arrow.

The control functions @1-@7 can be turned on and off from within a program. To do this, you insert a

POKE 16667,n

statement into your program at the point where you want to change the trace status. N is one of the control digits. That is not as easy as typing TRON or TROFF into a program; but in view of the extra capabilities, it's well worth the extra memorization (or peeks in the manual).

Boss also allows you to keep track of critical target variables. If you type @N, you are prompted to enter the list of the variables which most concern you. There is a limit to the number of variables you can specify: 128 variables for those with one character name lengths of eight variables 16-31 characters long. In case you're wondering what variable could have a 16 character name here is an example from the MULTIDOS manual. Its name length is 19 characters long, counting the subscripts: T#(F,(B(A,N), G(E))).

You can key @N and enter the variable specification dialogue while your program is running, or while in the Basic ready mode. Once the variables have been selected, pressing @0 allows you to see the current values of those variables. Also, @0 gives you an opportunity to edit the variable list. To return control to your Ba-

sic program press Clear twice and wonder of wonders, your program's display restores itself and execution continues with the screen looking just as it did before the interruption.

So, how much free memory is available with Boss Basic and all its extra goodies loaded? 38669 bytes. Boss Basic leaves you more user memory than the Basics of TRSDOS, NEWDOS 2.1 (or 80), LDOS, or DOSPLUS (full size or tiny). Vernon, you've done it again!

Dead is much like Clear, except it does not restrict itself to the range between 5200 and TOPMEM. It zeros memory from 4000H (the start of RAM) to the top of physical memory. This effectively causes a reboot with a clean memory slate. To reboot without reinitializing memory, you simply enter Boot.

Auto in MULTIDOS is somewhat better than other DOS Autos. Here the Auto statement may contain several DOS commands instead of just one. You can make an Auto command undefeatable, in-the-sense that holding down Enter during boot-up will not prevent its execution. To do so, use an exclamation mark (!) before the Auto command. For example: !BASIC

COOSOL DISCOUNTS

PRINTERS

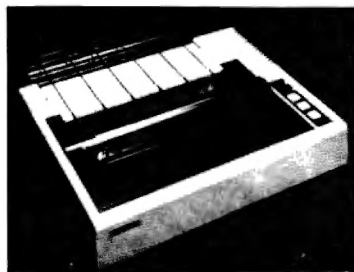

- EPSON MX70 CALL
- EPSON MX80 CALL
- EPSON MX80 F/T CALL
- EPSON MX 100 CALL
- NEC PC-8023A-C \$555
- ANACOM ANC150P OR S \$1195
- ANACOM ANC160P OR S \$1465
- TALLY MT-1602 OR 5 \$1495
- TALLY MT-1802 OR 5 \$1795
- NEC 3510-1, 3515-1, 3530-1 \$1795
- NEC 7710-1, 7715-1, 7730-1 \$2495
- NEC 7720-1, 7725-1 \$2995
- C.I.TOH FP 1500 25PU, H, OR Q \$1350
- C.I.TOH FP 1500 25RU \$1450
- C.I.TOH FP 1500 45PU QR Q \$1795
- C.I.TOH FP 1500 45RU \$1995
- HP-PRINTERS \$ CALL

HEWLETT PACKARD



- HP-125 Microcomputer \$2995
 - HP-85A Microcomputer \$2195
 - HP-83A Microcomputer \$1595
 - HP 85/83 16K Memory Module .. \$169
 - HP7225B Graphics Plotter \$1959
 - HP-5 1/4" Dual Disk Drive \$1995
 - HP-5 1/4" Single Disk Drive \$1249
 - HP 8" Dual Disk Drive \$5395
 - HP-Other Mass Storage Units .. CALL
 - HP-9111A Graphics Tablet \$1595
 - HP Firmware CALL
 - HP Software Packages CALL
 - HP Interfaces CALL
- OTHER COMPUTERS**
- ALTOS MTU/Floppy/Harddisk . CALL
 - ADDS Computer Systems CALL
 - ATARI Computer and Accessories CALL

NEC COMPUTER



- NEC Computer PC-8001A CALL
 - NEC I/O Unit PC-8012A CALL
 - NEC I/O Port PC-8033A CALL
 - NEC Disk Drive PC-8031A CALL
 - NEC Disk Drive PC-8032A CALL
 - NEC Dot Printer PC-8023A-C .. CALL
 - NEC GR Monitor JB-1201 CALL
 - NEC COL Monitor JC-1202 CALL
 - NEC Accessories & Software ... CALL
- TELEVIDEO TERMINALS**
- 910C \$595
 - 920C \$750
 - 912C \$705
 - 950C \$959
- ADDS Viewpoint WB2101 or WB2102 \$595

Calif.(714) 545-2216 (800) 854-8498

COOSOL, INC. P.O. BOX 743, ANAHEIM, CALIFORNIA 92805-0743 ✓ 105

New From Intersoft

LIBEDIT

a complete library manager for the TRS-80 and CP/M

- Allows you to build libraries of relocatable object code (such as that produced by Macro-80, Fortran-80 and other Microsoft languages)
- Libraries can be automatically searched by the "-S" option of Link-80, just like forlib .rel
- Modules can easily be added to or deleted from existing libraries; you can even extract individual .rel files to disk
- Useful 'liblist' utility gives detailed description of a library's contents

Specify Model I, Model III or CP/M when ordering.
Price for complete package . . . \$100

Intersoft C 2.5

an improved and enhanced version of our popular compiler for the C programming language

- Comes complete with over 40 supporting library functions including several new additions (such as in-memory sorts and scanf())
- Source code for all library functions included on disk
- Fully compatible with both Macro-80 and EDTASM; no knowledge of assembler required

Specify Model I, Model III, CP/M or 6809 Flex when ordering; also specify assembler (Macro-80, EDTASM, ASM or TSC)

Complete package \$100
Manual only \$ 20

(Cost of manual discounted from cost of complete package)

Ontario residents please add 7% Provincial Sales Tax.

Intersoft Unlimited

Box 383 Station C, Kitchener-Waterloo Ontario,
N2G 3Y9, Canada (519) 884-3557

Link-80, Macro-80 and Fortran-80 are trademarks of Microsoft
TRS-80 and EDTASM are trademarks of Tandy Corp.
CP/M is a trademark of Digital Research

✓519

Model II & Model 16 users:

ANNOUNCING

two/sixteen magazine

You've been ignored long enough! The time has come for a magazine tailored to your special needs as a Model II user. Advent of the Model 16 will increase demand for coverage of matters specific to our very versatile micros. **two/sixteen** will discuss topics of interest to all II/16 owners, from the casual to the advanced user. Articles will be slanted toward the business, professional, and scientific community (but we'll lapse into games and other diversions from time to time). You will see features about networking, CP/M vs. TRSDOS, deciding on hard disk, patching an Epson's power into WordStar, multi-user processing on the 16, and adding the Model 16 enhancement to your Model II. As a non-dealer subscriber, you can place low-cost classified ads. **two/sixteen** is not affiliated with Tandy Corporation.

Charter subscriptions are now available starting with the May-June, 1982 issue. \$30 annually in the U.S. Foreign subscribers inquire for rates. Phone orders accepted at (717) 393-1917 (VISA and MasterCard). Send mail orders to **two/sixteen magazine**, 216 1/2 West James St., Lancaster, PA 17603.

✓522

Introducing low cost, TRS-80 compatible disk drives

Up to one megabyte for Models I and III

Low Cost Storage

Model III Internal Drives

- single sided, 40 tracks with 250K \$215
- double sided, 40 tracks with 500K \$335
- double sided, 80 tracks with 1000K \$435

Model I and III External Drives

(Includes disk drive, power supply, cable and color coordinated cabinet)

- single sided, 40 tracks with 250K \$315
- double sided, 40 tracks with 500K \$435
- double sided, 80 tracks with 1000K \$535



External and internal mounting

Now you can have up to one megabyte of unformatted storage for your TRS-80 Model I or III. Drives can be mounted internally or externally on the Model III and externally on the Model I.

Eight color cabinets to choose from

Cabinets for external mounted drives are available in black, chrome, off-white, lime green, dark green, bright orange, computer blue, and brilliant yellow.

Unconditional warranty and service

90-day unconditional warranty plus service center for out-of-warranty service. For more information on the TRS-80 compatible disk drives, call or write:

I² INTERFACE, INC.
20932 CANTARA STREET
CANOGA PARK, CALIFORNIA 91304
(213) 341-7914

Dealer and quantity discounts available upon request. MasterCard, VISA or COD orders accepted. TRS-80 is a registered trademark of Tandy Corporation.

✓182

Notes from BENEATH the KEYBOARD

RUN ACCOUNTS. If instead of "!" you use "#" (pound sign), the Auto line will be invisible on boot-up. If you enter AUTO #CLOCK, the next time you boot-up, the clock display will immediately be turned on, but you will not see the word Clock on your screen.

The Break command is a switch to enable and disable the Break key. This can be used in combination with the undefeatable Auto statement to produce a disk which will always load and run an UNBREAKABLE Basic program. This could be useful when you have to entrust certain critical operations to an unsupervised employee.

Since VTOS introduced the concept of device independence to TRS-80dom, most DOSs have included commands like Route or Link, MULTIDOS has both. Their application is limited to the video (DO) and printer (PR) devices. Route PRDO will video display anything which would normally have been printed. This is useful for people without printers. Route DOPR does the opposite. Link PRDO will cause information to be both printed and displayed. These two features are a far cry from the true device independence of VTOS and LDOS, but they are useful nonetheless.

MULTIDOS's KEYBRD (for keyboard) and CONFIG (for configure) commands perform a similar set of functions to those performed by the System command of some other DOSs. They allow you to custom reconfigure MULTIDOS to your own specifications. KEYBRD lets you enable or disable the lowercase driver, the graphics driver, key repeat, the clear key and the blinking cursor. It also lets you select your own cursor character.

The effect of the KEYBRD command is not immediate. It takes effect the next time you boot-up the disk. If you have enabled the lowercase driver, MULTIDOS makes sure your system is capable of displaying lowercase before turning it on.

CONFIG lets you alter and display default power-up drive attributes. This refers to the density (single or double) and stepping rate (6, 12, 20, or 40 ms) of each disk. If the default density setting is incorrect for a particular drive, MULTIDOS's automatic density recognition detects this and ensures that you still have proper disk I/O.

MULTIDOS's DEBUG module has some unique features. Like the standard DEBUG package, you can use I to execute a single machine language instruction, or C which has the same effect, except that CALLED or RESTARTed routines are executed in full. However, MULTIDOS's DEBUG has an automatic continuous repeat mode for each of these commands allowing you to perform high speed ma-

chine language traces. This is analogous to Basic's TRON.

MULTIDOS's Forms command is similar to those of several other DOSs. It lets you establish print formatting parameters for printing operations performed by DOS and Basic. You can define such factors as the width of the print line, the length of a page and the number of blanks between pages. MULTIDOS does not provide left margin control.

Utilities

These days the big buzz phrase is *user-friendly*. That description is probably more applicable to MULTIDOS than to other Model 1 DOS. A primary reason for this is MULTIDOS's Help file. Like Models 2 and 3 TRSDOS, MULTIDOS will show you the syntax for most of its commands, without sending you to the manual. To see the proper syntax for using the Dump command, you enter Help Dump, and the information is displayed.

Skip is a utility for reading 35 or 40-track disks on an 80-track disk drive. This is extremely useful for people (like me!) who

"Boss Basic has all the features of SuperBasic plus its own specialties."

have upgraded to a higher capacity disk drive only to have trouble accessing the files on their old disks. Even if you've had 80-track drives right from the start, most of the disk software you buy comes on 35-track disks.

MULTIDOS' Spool utility, like others of its ilk, allows printing operations to take place while you do other computer work, instead of tying up the system until the printout is finished. MULTIDOS's Spool lets you specify the size of the RAM buffer used for this purpose. In my experiments with spool, I found that when I selected a large buffer, the keyboard response seemed as fast as if no printing was taking place, even though my MX-80 was chugging away. But when I selected the smallest allowable RAM buffer (256 byte), it was as if there was no spooling operation in effect at all. I had to wait until the printout was finished before the keyboard would listen to me.

VFU is MULTIDOS's Versatile File Utility. It allows you to perform a number of disk functions. They are Copy, Execute, Purge and Hard Copy. The Copy and

Purge functions allow you to deal with groups of files, without the repetitious input required for Killing or Copying them one at a time. If you want to copy 10 files from the disk in drive zero to the disk in drive one, you enter VFU by typing VFU. You then get a menu of choices. If you press C for Copy, you can then choose between a selective or total copy. If you key S for Selective, you will be asked whether invisible files should be included—likewise for system files. Then you are prompted to enter source and destination drive numbers. In the example we are considering, you would enter 0 and 1, respectively.

A directory of the source drive will then be put on the screen. It will contain only the files belonging to the classes you specified. In other words, invisible or system files will not be presented if you had not selected those categories during the preceding dialogue. This VFU directory display is actually a menu. You can move the cursor from entry to entry. Keying Y will tell VFU the file under the cursor is to be copied. In our example, you would specify the 10 files you want copied. Then, you would press Enter and all 10 files would be copied to the destination disk without your having to type another keystroke.

Purge works the same way as Copy, except the specified files are Killed, instead of copied. Execute does the same thing that typing in a file's name directly from DOS would do. I do not see any advantage to using VFU for this purpose. Hard Copy prints out a listing of a disk's directory, suitable for keeping in a disk jacket.

GR is the graphics utility I referred to earlier. You select it by typing GR, or through the KEYBRD command. It can be enabled or disabled by using the Shift Clear key as a toggle. When enabled, it allows you to type any graphics character directly from the keyboard.

RS stands for RAM Scan. This utility allows you to search memory for any byte or word. You can tell RS to only report occurrences of the target value which are the object of certain machine language instructions. The parameters allowable in a RAM Scan search are:

Call	Non
Carry	Sign Positive
Jump	Parity Even
Load	Parity Odd
Sign Minus	Zero

They all have one letter abbreviations.

Again, I am not sure just what the normal application of this utility is. But just when I had decided it was fairly useless, I had occasion to employ it.

It seems I cannot write anything these days without bumping my head against

one aspect or another of the software copyright controversy. Well, here we go again. Apparat has received criticism because their original DOS, NEWDOS 2.1, was mostly enhanced Tandy code. Their literature only documented the enhancements, leaving the bulk of the DOS undocumented thus forcing users to obtain TRSDOS legitimately in order to decipher NEWDOS. This was their gesture of protection to Tandy.

Back in those days, TRSDOS was a pretty flaky system. Tandy was not doing a great job of supporting it, either. It was lucky for all of us that NEWDOS came out when it did. In my opinion, Apparat greatly contributed to the TRS-80's success by making it a more powerful, reliable system.

In NEWDOS Plus, Apparat did the same copy, enhance, but don't document trick with Microsoft's Editor/Assembler. Unlike TRSDOS, the Editor/Assembler was a fine product and Microsoft was not substandard in their product support. I believe Apparat did Microsoft an injustice in this case.

Now Vernon Hester has turned the

table on Apparat. He has taken the Apparat EDTASM, which is basically the Microsoft Editor/Assembler patched for a disk system, and added enhancements of his own. He has put the whole kit and caboodle on MULTIDOS under the name of EA. He only documented the portions he changed. Features unaltered from the Microsoft/Apparat version are not described.

It's a pretty good joke on Apparat—poetic justice you might say. It would be quite awkward for Apparat to protest. But it does perpetuate the injustice done to Microsoft. I am sure Hester meant no harm but as I'd rather not involve myself in the situation I will refrain from describing MULTIDOS's EA utility, other than by saying that it is there.

Documentation

The organization of MULTIDOS's documentation is similar to that of TRSDOS, starting with a general description of the DOS and its special features. The various library commands are then treated in alphabetical order. The utilities are dealt with next. Finally, the features of Super-Basic and Boss Basic are described. The

manual is replete with examples of user input and descriptions of their results. Anyone already familiar with TRSDOS or any other TRS-80 operating system should have no difficulty learning the ins and outs of MULTIDOS from its documentation.

Conclusions

MULTIDOS's Basic is unequalled, in both features and size, among TRS-80 Disk Basics. The DOS is probably the most universally compatible DOS, inter-system wise, of any TRS-80 operating system. It is not as comprehensive as LDOS or NEWDOS-80, but it is very fast with many unique and convenient features.

The price, at time of writing, is only about \$80, a low price for a DOS of this quality. This is partly because MULTIDOS lacks some utilities such as disk-zap and tape/disk programs. Hester is working to correct these omissions. As more utilities are added to MULTIDOS, the price may go up. If you use your system mostly for Basic programming, or would benefit from MULTIDOS's special compatibility, MULTIDOS might be a best buy for you. ■

Gosub International, Inc.

GOSUB'S MX80/70 Friction Feed Kit \$49.95 ppd

- Use Single Sheet Paper
- Use Your Own Letterhead
- Use Inexpensive Roll Paper
- Does Not Affect Pin-feed Use

PRINTERS PRINTERS PRINTERS

EPSON MX80...\$545 ppd. EPSON MX100...\$825 ppd

THE PRINTER STAND.....\$29.95

SAVE MONEY AND SPACE—Holds almost any printer that uses 9 1/2" size paper or forms. Made from 1/4" acrylic, allows 3" of paper or forms to be stacked under printer. Great for use with bottom load printers! Fits MX80/70-Microline 80's BASE 2-850 Bytewriter-1 and many more!

AUTHORIZED DEALERS FOR THE GOSUB FRICTION FEED KIT
 USA—Alpine Computer Center, 2526 S. Alpine Rd., Rockford, Ill. 61108, (815) 229-0200; OMEGA Micros, 3819 West Michigan St., Milwaukee, WI 53208, (414) 933-6088; EXATRON: 181 Commercial St., Sunnyvale, CA 94086, (800) 538-8559/CA, (408) 737-7111.

CANADA—Microwest Dist. Ltd., 1940 Larson Rd., North Vancouver, B.C., Canada V7M 2Z8, (604) 988-9998 or 988-6877.

AUSTRALIA—Computer Campus Pty. Ltd., 11 Rundle Street, Kent Town, South Australia, 5067, ph. 08.424826, telex 88156.

STRATEGY SIMULATIONS FOR THE TRS-80

MERCENARY FORCE

Command a mercenary army. Decide the number of men, type of weapons, armor, air support, medical aid and transports. Battle the enemy in jungles, underwater, on moons and in space. (1-4 players)
TRS-80 L2/16K \$16.95

SPACE MERCHANT

Build an Empire in the stars. Choose your cargo, means of shipping, and security. Risk pirates, ion storms, engine failure and other hazards while you try to become a Space Merchant. (1-6 players)
TRS-80 L2/16K \$9.95

80 SPACE RAIDERS

Starship Simulator and Combat Game

This is the most realistic combat space simulation available for any computer system anywhere! Operator is placed in a rapidly moving ship looking out through a window into the depths of space. Thousands of stars appear in the distance and part toward the screen edges as the ship flashes past. Forward and aft views available at any time. Accurate celestial navigation using both XYZ: a spherical coordinates! Comment from Aug. '81 *80 Microcomputing*: "May be the ultimate Star Trek-type game and, possibly, the most complex microcomputer game ever attempted"! Fast action graphics never stop!

Model 1/Level 2/16K

\$24.95

SOFTWARE

Software for the VIC 20 and Color Computer

SPACE MERCHANT—See Strategy Simulations for the TRS-80

WARRIOR—Head to head combat in a game where you and your opponent are the rulers of warring city-states, each trying to destroy the other. You decide how many of your population will be warriors, farmers, factory workers, and scholars.
\$9.95

YAHTZEE! \$10.95

GAME PACK #1 Quarter Horse and Yahtzee.....\$14.95

GAME PACK #3 Warrior and Space Merchant.....\$14.95

Kansas residents add 3% sales tax
 All prices subject to change without notice
FREE CATALOG UPON REQUEST
 (TRS-80) is a trademark of Tandy Corp.)
 Dealer Inquiries Invited
SEND CHECK OR MONEY ORDER



Gosub Int'l, Inc.
 501 E. Pawnee, Suite 430
 Wichita, KS 67211
 (316) 265-9659

GOSUB International (New England Division)
 P.O. Box 2586
 Framingham, MA 01701
 (add 5% sales tax)

GOSUB
 P.O. Box 275
 Wichita, KS 67201
 (316) 265-9992

MONEY DOS

an operating system for financial survival

by J.M. Keynes



"A Chimpanzee making random decisions is favored to outperform the stock market."

The brokerage business offers little education about the finest investment medium for most investors. I speak of Convertible Securities which include certain bonds and preferred stocks. Had you randomly invested \$10,000 in convertibles in 1972 today it would show a profit of over 40 percent while a like amount randomly invested in common stock would show a loss of 20 percent. In fact, \$10,000 invested in carefully chosen convertibles since 1972 would be worth over \$250,000 today! I have taken the figures from The Value Line Convertible Survey. You may wonder why your broker never mentioned an investment wherein a Chimpanzee (making random decisions) is favored to outperform the stock market. Chances are he has little expertise in this area. It is seldom that I find a brokerage firm recommending a convertible. Not that they are unaware of their advantages. There simply are not enough to go around. Most convertibles are relatively small (number of bonds or preferred stock outstanding), and, should a major firm put out a buy recommendation chaos could result. For example: In April 1980 a bond issued by Allegheny Ludlum was selling for 88 or \$880 per bond. The bond carried a five percent coupon (paid \$50 in interest yearly) and matured October 1, 1982. It was convertible, at the option of the bondholder, into 28.8 shares of the issuer's common stock. At that time Allegheny Ludlum common was selling for \$26 per share. The value of the bond if converted to common stock was 28.8×26 or \$748.80. So was it a good deal at 88? Not only good but spectacular! Examine the analysis: The issuing company had paid dividends on their common stock each year since 1935 and was in an excellent financial condition, so the bond interest payments and the redemption on October 1, 1982 must have been considered safe. If nothing good happened to the price of the common stock within 18 months you would let the bond mature. In the worst case you would have received \$75 in interest and, at maturity, \$120 long term capital gain profit (1000 rec. minus 880 paid). The \$120 long term gain will yield a net of at least \$96 after taxes (if in 50 per-

cent bracket) which would be the same as making \$192 ordinary income from a T-Bill or CD. This, plus the interest received of \$75, equals an investment which would have returned the same after taxes as a CD paying 20.2 percent. There was no such animal... and this was worst case! As it turned out, the common stock went up to over \$50 at which time the bond was worth 28.8×50 or \$1,440 in common stock. It's true that in this case buying the common stock would have been more profitable as it increased 92 percent while the convertible bond went up only 63 percent... but... my stock selections don't always go up (how sad)... so one must look at the risk side of the equation.

What if the stock price was \$13 today? The guy who bought the common at 26 would be biting his nails while you, the wise one who bought the convertible bond, would be waiting patiently for your 20 percent CD (the bond) to mature this

October. Had a brokerage firm advised its clients to buy this bond they would never have been able to fill the orders... because... only just over 4,000 of these bonds were ever issued. On any market day, perhaps ten to 50 of them were for sale. Most were held by professionals who saw no reason to sell. There is no point in getting clients excited about something they can't get at a favorable price. That would be bad PR. Furthermore, the commissions on common stocks are from two to six times what they are on bonds. Unavailable in quantity... not a high profit item (for the broker)... neglected... save for a few professionals.

I am frequently asked why companies issue convertible securities? If they need to borrow money why not just issue regular bonds? Another example is in order: The Board of Directors of the XYZ Company decides that the Company should borrow five million dollars to finance

Program Listing

```
10 CLS:PRINT:PRINT"PORTFOLIO ANALYSIS BY J. MAYNARD KEYNES
WRITTEN FOR 80 MICROCOMPUTING":PRINT:PRINT
30 CLEAR:DEFINT E
35 REM LINE 40 DIMENTIONED FOR 16K (20 SECURITIES) INCREASE IF
MORE MEMORY AVAILABLE
40 CLEAR5000:DIMAS(20),HS(20),A(20),B(20),C(20),D(20),E(20),F(20)
50 HH=0:Y=0:P=64: A1=50: Z$="###.#": X$="#####": K$="###.##": OS="$#####":
ONERROR GOTO 890
60 INPUT"FROM DISK=1 CREATE NEW PORTFOLIO=2 FROM CASSETTE=3":AA
70 IF AA=2 THEN HH=1:GOTO 230 ELSE IF AA=3 THEN 80 ELSE 150
80 CLS:PRINT@512,"WHEN CASSETTE RECORDER READY PRESS 'ENTER'.":INPUT:CLS:P
RINT@512,"STANDBY, LOOKING FOR SYNC BITE,"
90 CMD"t": INPUT*-1,A6,J5,J1,G1,H1,I1:
REM DELETE CMD"T" IF NO EXPANSION INTERFACE
100 CLS:PRINT@6;" ITEMS ARE BEING LOADED FROM CASSETTE
110 FOR I=1 TO A6: INPUT*-1,AS(I),A(I),B(I),C(I),E(I),D(I),F(I)
120 PRINT@S(I),: REM TO LET YOU KNOW SOMETHING IS GOING ON...
130 N=N+1: Y=Y+1
140 NEXT: A1=A6: CLS: GOSUB860: FOR I=1 TO A1: GOTO450
150 O=0:A1=1: INPUT"WHICH FILE DO YOU WANT?":PFS
160 INPUT"FROM WHICH DRIVE":W$
170 OPEN"I",1,FFS+":"+W$
180 REM DISK INPUT MUST BE MIRROR IMAGE OF HOW IT WAS SAVED.
190 IF O=1 THEN 150 ELSE IF EOF(1) THEN A1=A1-1:GOTO220
200 INPUT#1,AS(A1),A(A1),B(A1),C(A1),D(A1):A1=A1+1:Y=Y+1:
N=N+1:GOTO190
210 GOTO160
220 CLOSE:FOR I=1 TO A1:GOTO360
230 FOR I=1 TO A1
240 CLS: N=N+1: Y=Y+1
250 PRINT"SECURITY#";I: INPUT"NAME OR STOCK SYMBOL.":AS(I)
260 IF AS(I)="" THEN GOSUB 960
270 INPUT"NUMBER OF SHARES OWNED?":A(I)
280 REM LINES 250,270,300,320, & 340 PROVIDE RANDOM PRICES AND
DIVIDENDS IF YOU WANT TO GENERATE A RANDOM PORTFOLIO JUST
```

Program continues

☆☆ SUPER™☆☆ ISA's DATABASE

The only DBMS with all these features:

- ★ PROVEN in one year of test marketing
- ★ TOUGH, reliable file structure
- ★ MENU driven for simplicity and easy use
- ★ ARITHMETIC with stored calculations
- ★ FAST set-up and report formatting
- ★ CLEAR user-oriented documentation
- ★ PRINTS totals & subtotals - mail labels
- ★ REFORMATS and merges data files
- ★ MULTI-DISK files: Up to 128K records
- ★ SORTS full disks on up to 40 fields
- ★ PRODUCTION input of repetitive data
- ★ COUPLES to word processor & statistics
- ★ POSTS transactions to master file
- ★ SEARCH by strings, ranges, comparisons
- ★ DATA COMPRESSION: Over twice as many labels as the other system

For TRS-80* Models I, II, & III - 250.00

Ask your Dealer or Write -

Institute for Scientific Analysts, Inc.
P. O. Box 7186, Dept. M-1
Wilmington, DE 19803 (215) 358-3735

*TM Tandy Corp.

✓351

Sick of the same TRS-80 software?

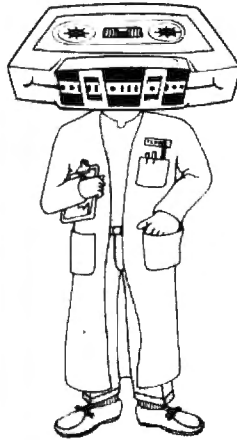

Here's a CHEAP CURE!

The prescription for the Model I and III:
CLOAD Magazine!

A CASSETTE TAPE with 6 to 8 programs a month!

Some past sensational medications:

Game — Caterpillar, Suns, CIA Adventure, Reverse
Practical — Securities, Energy, Tape Directory, Checkbook
Utility — Variable Dump, Display, Edit, Code It.
Tutorial — Planets, Spell Egg, Atomic Table, Geometry

At about **75 cents** a program, a subscription to **CLOAD Magazine** is just what the doctor ordered.

The Bottom Line:

1 year (12 issues) \$42.00
6 months (6 issues) \$23.00
Single copies
Back issues \$ 4.50
Good Games #1 \$12.00
Adventures #1 \$13.00

*Temperature and prices rising July 1, 1982

California residents add 6% to single copies
North America — First Class Postage Included
Overseas — add \$10 to subscriptions, and \$1 to single copies Sent AO rate

The Fine Print

All issues from Oct '78 on available — ask for list (24 Level I issues also)
Programs are for 16K Level II, 16K Model III, and occasionally for disks
TRS-80 is a trademark of Tandy Corp
MasterCard/Visa welcome!

CLOAD Magazine Inc.
P.O. Box 1448, Santa Barbara,
CA 93102 (805) 962-6271

✓102

TRS-80* MAGIC

MOD I IMPROVES LOW SPEED III TOO!
— THE AMAZING —



ONLY
\$12**
POSTPAID

TAKE THE LOAD OFF YOUR MIND!

Tired of finicky model one cassette loads? You can end them with the LemonAid Loader. And don't be fooled by its low price. It uses newly developed signal-active filters that focus, shape, and size EACH tape pulse. You can often reliably load "impossible" tapes, and "Possible" tapes load the first time everytime! And it not only SYSTEM and CLOADs, but it is fully compatible with software tape speedups and operating systems like KWICOS** too. And plug a speaker or earphone into the extra output jack for optional tape monitoring also. Install the LemonAid in seconds. Just plug between CTR and computer. It needs no power, no software, no rewiring, no adjustments, and there's no tricky CTR volume settings. Skeptical? Let us take the risk. Use the LemonAid Loader for 15 days, and then, if you can do without it, return for full \$12.99 refund, NOA. Order the LemonAid Loader today from:

LEMONS TECH SERVICES

325 N. HWY. 65 P.O. DRAWER 0429
BUFFALO, MO. 65622 (417) 345-7643

* TRS-80 is Trademark Tandy Corp.
** KWICOS is Trademark Vitek Software

✓358

BUILD THIS DIGITAL PLOTTER AT HOME FOR UNDER \$200.00

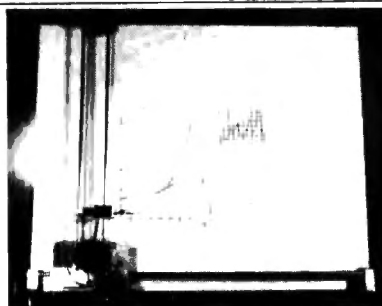

FOR \$19.95 YOU GET PRO QUALITY BLUE-PRINTS, SCHEMATIC, PARTS LIST, ASSY. INSTRUCTIONS AND NECESSARY SOFTWARE FOR MODEL I OR III. ACCOMMODATES PAPER UP TO 18 X 24. ADD \$9.95 FOR 10 PROGRAMS INCLUDES PLOTTING GRAPHS, RADII NUMBERS A 3-D CUBE AND MORE.

SEND CHECK OR MONEY ORDER TO. ✓352

P.M.W. 7741 ALABAMA AVE. #8
CANOGA PARK, CA. 91304

For the Extended BASIC COLOR COMPUTER POCKETBOOK SURGERY NOT REQUIRED

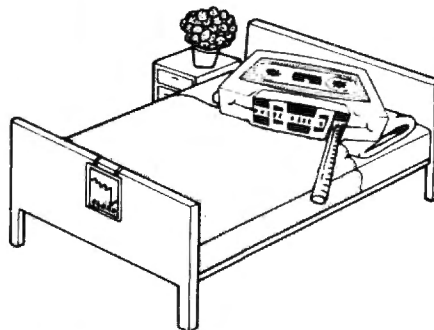

Is your CoCo table ridden, drinking up electrical juice but not getting any software solids? A prescription will stop the hardening of the ribbon cables.

The doctor explained that **CHROMASETTE Magazine** is a cassette tape with 6 to 8 quality programs on it. A healthy mixture of games, tutorials, utilities, and practical programs to nurture your computer every month. No finger exercises necessary. Just load and run.

Keep CoCo's health costs low. A subscription to **CHROMASETTE Magazine** is good, cheap medication (under 75 cents a program).

The Bottom Line:

1 year (12 issues) \$45.00
6 months (6 issues) \$25.00
Single copies \$ 5.00

Calif. residents add 6% to single copies.
North America — First Class Postage Included.
Overseas — add \$10 to subscriptions, and \$1 to single copies Sent AO rate.

MasterCard/Visa welcome!

The Fine Print:

All issues from July 81 on available — ask for list. Programs are for the Extended BASIC model only.

MasterCard/Visa welcome!

Chromasette Magazine Inc.
P.O. Box 1087 Santa Barbara,
CA 93102 (805) 963-1066

✓103

MONEY DOS

Program continued

```
FOR FUN. JUST PRESS 'ENTER' RATHER THAN ENTERING STOCK
NAME AND PRICES ETC.
290 IFA(I)<1 THEN A(I)=RND(500)
300 INPUT"PRICE PAID PER SHARE EG. 36 3/8 = 36.375";B(I)
310 IFB(I)<.1 THEN B(I)=RND(50)
320 INPUT"CURRENT VALUE PER SHARE.";C(I)
330 IF C(I)<.1 THEN C(I)=RND(50)
340 INPUT"CURRENT YEARLY DIVIDEND EG. 80 CENTS= .80";D(I)
350 IFD(I)<.001 THEN D(I)=RND(0)+1
360 E(I)=(A(I)*C(I))-(A(I)*B(I)): REM P/L ON EACH SECURITY
370 J1=J1+E(I): REM TOTAL PROFIT/LOSS
380 F(I)=D(I)/C(I)*100: REM YEARLY % RETURN
390 G1=G1+(C(I)*A(I)): REM TOTAL VALUE
400 H1=H1+(D(I)*A(I)): REM TOTAL DOLLAR RETURN
410 I1=H1/C1*100: REM TOTAL PERCENTAGE RETURN ON PORTFOLIO
420 IFH1=1THENINPUT"TO END =1 FOR ANOTHER ENTRY PRESS 'ENTER'.":N1:IFN1=1T
HENAL=N:GOTO440
430 NEXT I
440 CLS:GOSUB860:FOR I=1 TO A1
450 PRINT@P+1,A$(I)
460 PRINT@P+16,A(I):PRINT@P+24,B(I):PRINT@P+33,USINGZ$;C(I):
PRINT@P+42,USINGX$;E(I):PRINT@P+49,USINGK$;D(I):
PRINT@P+57,USINGK$;F(I)
470 U=U+1:IFU=14 THEN P=0:INPUT"NEXT PAGE, PRESS 'ENTER'":A9:U=0:CLS:G
OSUB860
480 P=P+64: NEXT
490 PRINT"FOR RECAP OF TOTALS, PRESS 'ENTER'":INPUTD$:
CLS:PRINT:PRINT
500 PRINT"PORTFOLIO VALUE = ";:PRINTUSINGO$;G1
510 PRINT"TOTAL YEARLY RETURN = ";:PRINTUSINGO$;H1
520 PRINT"PERCENTAGE RETURN ON CURRENT VALUE = ";:PRINTUSINGK$;I1
530 IFJ1<.1 THEN J$="LOSS" ELSE J$="PROFIT"
540 PRINT"TOTAL PORTFOLIO HAS A CUMULATIVE ";J$;" OF ";:
PRINTUSING"$$$###.##";J1
550 HH=0:PRINT:PRINT"SAVE OR PRINT OUT FILE =99 RE DISPLAY=0 ":IN
PUT"ADD ANOTHER SECURITY ENTER HOW MANY";A2:IFA2=0 THEN U=0:P=64:GOTO4
40 ELSE IFA2=99 THEN 560 ELSE A1=Y+A2:P=64:U=0:FOR I=Y+1 TO A1:GOT
O240
560 CLS
570 PRINT"SAVE FILE TO DISK = 1
580 PRINT"TO PRINTER = 2
590 PRINT"TO CASSETTE = 3
600 INPUTA4
610 IFA4=2 THEN 710 ELSE IF A4=3 GOTO680
620 O=0:INPUT"NAME OF FILE TO BE SAVED TO DISK";Y$
630 INPUT"TO WHICH DRIVE?";W$
640 OPEN"O",1,Y$+"":W$
650 CLS:PRINT@518,"SAVING TO DISK"
660 IFO=1 THEN 620
670 FOR I=1 TO A1:PRINT#1,A$(I);",";A(I);B(I);C(I);D(I):NEXT:CLOSE:GOTO
550
680 CMD"R":REM DELETE IF
NO EXPANSION INTERFACE
690 A6=A1:CLS:PRINTA6;" ITEMS ARE BEING SAVED TO CASSETTE":
PRINT#-1,A6,J$,J1,G1,H1,I1
700 FOR I=1 TO A1:PRINT#-1,A$(I),A(I),B(I),C(I),E(I),D(I),F(I):NEXT:GOTO
550
710 IFFPEEK(14312)<>63 THEN CLS:GOTO900
720 FOR I=1 TO 64:LPRINT"$";:NEXT:LPRINT:LPRINT"."
730 LPRINT"SECURITY NAME";"SHARES "; " COST "; " CURRENT "; " P/L"; " D
IV. "; " % RETURN"
740 REM PRINTER ROUTINE
750 FOR I=1 TO A1
760 LPRINTTAB(1)A$(I);
770 LPRINTTAB(16)A(I);:LPRINTTAB(24)B(I);:LPRINTTAB(33)USINGZ$;C(I);:LPR
INTTAB(42)USINGX$;E(I);:LPRINTTAB(49)USINGK$;D(I);:LPRINTTAB(57)USINGK$;F
(I)
780 NEXT
790 LPRINT:LPRINT:LPRINT
800 LPRINT"PORTFOLIO VALUE = ";:LPRINTUSINGO$;G1
810 LPRINT"TOTAL YEARLY RETURN= ";:LPRINTUSINGO$;H1
820 LPRINT"PERCENTAGE RETURN ON CURRENT VALUE = ";:LPRINTUSINGK$;I1
830 IFJ1<.001 THEN J$="LOSS" ELSE J$="PROFIT"
840 LPRINT"TOTAL PORTFOLIO HAS A CUMULATIVE ";J$;" OF ";J1
850 GOTO550
860 PRINT"SECURITY NAME";"SHARES "; " COST "; " CURRENT "; " P/L"; " DI
V. "; " % RETURN":RETURN
870 REM IN CASE A MISTRAKE IS MADE!
880 CLOSE:O=1:CLS
890 O=1:FOR V=1 TO 6:PRINT"ERROR! WRONG DRIVE OR FILESPEC":PRINT:NEXTV:RESU
ME:NEXT
900 PRINT@514,"TURN ON YOUR PRINTER DUMMY!"
910 INPUT"IS YOUR PRINTER ON Y/N";CS:IFCS="N" THEN 550
920 IFFPEEK(14312)=63 THEN 720
930 CLS:FOR I=1 TO 26:
PRINT"QUIT TRYING TO FOOL ME...TURN THE %&$% PRINTER ON":
FOR O=1 TO 50:NEXTO,I:GOTO710
940 DATA CRISISLER,WAYNE GREEN INC.,80 US,DINGBAT COMPUTER,DOS MINUS,E.F. M
UTTON,MERRELL CINCH,SCHEME WITTER,PAIN ROBBE
950 DATACRAP APPLE,TANDY DANDY,JERKCOM DATA,NEVER SAY DIE,END
960 READ$;IFH$="END"THEN RESTORE:GOTO960 ELSE A$(I)=H$:RETURN
```

some new plant construction. They contact an Underwriter (The investment firm that sells the bonds...Merrill Lynch, Dean Witter, or some other) and explain their need for long term financing.

The underwriter determines (based on the company's credit rating) that they will have to pay 17 percent interest to attract investors. On \$5 million this means a debt service of \$850,000 per year (5,000,000 x .17). The underwriter proposes an alternative which will reduce the debt service by \$150,000 per year. The company can sell the bonds with a 14 percent coupon if they will add something to sweeten the deal. The company owns one million shares of their common stock which they repurchased in the market. The current stock price is \$15 per share. The underwriter suggests that they make each bond convertible into 50 shares of common stock. So the deal comes to market as a 20 year 14 percent bond which is convertible into 50 shares of the company's common stock.

"The astute investors who buy the bonds have part of the best of both worlds."

The astute investors who buy the bonds have part of the best of both worlds. The conversion value of the bond at issue date is \$750 (50 x 15). The investor gives up three percent in current yield (fully taxable) for long term capital gain potential. Suppose the company does well and 2 years hence the common stock is selling for \$30 per share. The bond must be worth \$1,500 (50 x 30). Almost all bonds have a "call" provision. This gives the company the right to "call" (redeem) the bonds at a stipulated price, usually three to five percent over face value (\$1,000). If XYZ common rose to \$30 per share, the board might consider "calling" the bonds. In this case it would force conversion into their common stock because no one will let the bond go for the call price (\$1050) if they can sell in the open market for \$1,500. By "calling" the bonds, the company does away with the \$750,000 debt service of the bonds. Should the price of XYZ go down to \$7.50 per share rather than up to \$30, the

THE BOOKKEEPERS

FOR INFO CALL (603)-447-2745

- Intermediate Bookkeeper—48K, 2 Drive & Printer.....\$109.95
 Ann Rose, our Accounts Receivable Clerk—
 48K, 2 Drive & Printer..... \$150.00
 The Count—A variety of utilities such as weight, area and capacity conversions;
 loan amortization; hex code conversion, etc.
 48K disk..... \$49.95

All programs are for TRS-80™ Model I or III

STURDIVANT & DUNN, INC. ✓180

BOX 277, 124 WASHINGTON ST., CONWAY, N.H. 03818

(TRS-80 is a trademark of the Tandy Corp.)

CompuServe: What's in it for the 80s?

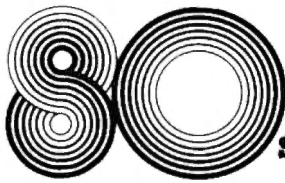

Plenty! First there's MNET80, a Special Interest Group (SIG) of TRS-80 users on the CompuServe Information Service. SIGs are active and growing groups of individuals who share a common interest and form an "electronic" club using the CompuServe Information Service as its communications medium. Share advice and exchange information with other TRS-80 users across town or anywhere around the country. TANDY services include an electronic newsletter, answers to your questions directly from Ft. Worth, product availability, tips and hints.

Secondly, we think you'll like the CompuServe Information Service: CB simulation, electronic mail, news wires, financial information, games, data bases, programming languages, big mainframe computer power and free data storage. All for a basic charge of only \$5.00 an hour nights and weekends. All you need is your TRS-80, a modem and some inexpensive software. See a free demonstration of CompuServe in action at your Radio Shack "Computer Center. CompuServe Information Service, 5000 Arlington Centre Blvd., Columbus, Ohio 43220. (614) 457-8650.

CompuServe

✓ 235

REMSOFT, INC.

Let Your TRS-80® Teach You ASSEMBLY LANGUAGE

Tired of buying book after book on assembly language programming and still not knowing your POP from your PUSH?

REMSOFT proudly announces a more efficient way, using your own TRS-80* to learn the fundamentals of assembly language programming -- at YOUR pace and YOUR convenience.

Our unique package, "INTRODUCTION TO TRS-80* ASSEMBLY PROGRAMMING", will provide you with the following:

- Ten 45-minute lessons on audio cassettes
- A driver program to make your TRS-80* video monitor serve as a blackboard for the instructor.
- A display program for each lesson to provide illustration and reinforcement for what you are hearing.
- Step-by-step dissection of complete and useful routines to test memory and to gain direct control over the keyboard, video monitor, and printer.
- How to access and use powerful routines in your Level II ROM.

Presently available for Model 1 only
REMASSEM-1 (tape) only \$69.95
REMASSEM-1 (disk) only \$74.95

LEARN TRS-80® ASSEMBLY LANGUAGE DISK I/O

Your disk system and you can really step out with REMSOFT'S Educational Module, REMDISK-1, a "short course" revealing the details of DISK I/O PROGRAMMING using assembly language.

Intended for the student with experience in assembly language, using the same format as our extremely popular introduction to assembly language programming, this "ASSEMBLY LANGUAGE DISK I/O PROGRAMMING" course includes:

- Two 45-minute lessons on audio cassette
- A driver program to make your TRS-80* video monitor serve as a blackboard for the instructor.
- A display program for each lesson to provide illustration and reinforcement for what you are hearing.
- A booklet of comprehensive, fully-commented program listings illustrating sequential file I/O random-access file I/O, and track and sector I/O.
- A diskette with machine-readable source codes for all programs discussed, in both Radio Shack EDTASM and Macro formats.
- Routines to convert from one assembler format to the other.

Presently available for Model 1 only
REMDISK-1 only \$29.95

Dealer inquiries invited

These courses were developed and recorded by Joseph E. Willis and are based on the successful series of courses he has taught at Meta Technologies Corporation, the Radio Shack Computer Center, and other locations in Northern Ohio. The minimum system required is a Level II, 16K RAM.



REMSOFT, INC.
 571 E. 185 St.
 Euclid, Ohio 44119
 (216) 531-1338



SHIPPING CHARGES:
 \$2.50 WITHIN UNITED STATES
 \$5.00 CANADA AND MEXICO
 OTHER FOREIGN ORDERS ADD 20%
 OHIO RESIDENTS ADD 5 1/2 % SALES TAX

TRS-80* IS A TRADEMARK OF TANDY CORP.

✓129

NOW AVAILABLE!

PROFESSIONAL SOFTWARE **TRS-80® MODEL II & 16**

- BASIC COMPILER** BY MICROSOFT • EASY TO USE **\$339.00***
 • TRSDOS® 2.0 COMPATIBLE • INCLUDES M-80 & CREF-80
 • UP TO 30 TIMES FASTER • AUGMENTED WITH OUR DOCUMENTATION
- DISK SORT** • YOU DON'T HAVE TO BE A PROGRAMMER TO USE IT!
 • MENU DRIVEN • RANDOM FILES • EASY TO USE • SPEC'S SAVED ON DISK **\$69.99***
 • EASILY INSERTED INTO JOB STREAM FOR NON-STOP RUNNING • FULL DISK CAPACITY
 DOC ONLY \$10**
 DEDUCTIBLE ON PURCHASES

BASIC CROSS REFERENCE • SAVE HOURS!
 • SEE USED LINE#s/NAMES AT A GLANCE • PRODUCES NICE PROG LISTING • INDISPENSABLE **\$59.99***

EPSON MX-80 \$475.00 MX-100 \$764.00 HURRY-LIMITED TIME!
 DOC ONLY \$10**
 DED ON PURCH

PAPER 9 1/2 x 11 18lb WHITE STRIPS TO 8 1/2 x 11 3,000/BOX **\$25.00***

MAILING LIST • HIGH CAPACITY • SPANS DISK • NO SORTING **\$149.95***

• FAST RETRIEVAL-UPDATE • R/S CONVERSION INCLUDED • LONG/SHORT FORMATS
 DOC ONLY \$10**
 DED ON PURCH

*PLUS POSTAGE & HANDLING PRICES SUBJECT TO CHANGE WITHOUT NOTICE

TRS-80 & TRSDOS ARE REGISTERED TRADEMARKS OF TANDY CORP.

GOOD-LYDDON DATA SYSTEMS
 5486 RIVERSIDE DR., CHINO, CA 91710 ✓186
 (714) 980-4563 MASTER CARD or VISA accepted.

MONEY DOS

bond price will fall only about 10 percent because, unlike the common stock, it has a "floor" of what it's worth as an ordinary bond. Of course the bond can be sold at any time if one doesn't like the outlook for the company. All in all, convertibles offer companies and investors unique opportunities.

There over 700 convertibles available. Less than five percent of them offer far superior risk/reward ratios vis-a-vis the common stock. There are over 35 pieces of data which must be analyzed in order to select the best ones. My program is very large and must be on line to daily stock and bond quotations. This data is unavailable to most TRS-80 owners. If you have interest in following some of the outstanding convertibles write to me c/o 80 Microcomputing and I will see that you get a current printout which will include the

risk/reward ratio. . . that is, if the common stock goes up or down 25 or 50 percent, the effect it would have on the convertible's price.

Now let's talk about your current portfolio. . . which has likely been neglected. I am forever puzzled at your Dr. Jekyll-Mr. Hyde behavior. In your business you make objective, hard headed, decisions which are carefully thought out and monitored, yet in your investments you behave differently. For example: You hire Jones. If he does a poor job you make a simple, unemotional business decision. You fire him. If Jones does well you keep him. Why can't you approach your investments in the same successful way? When you buy stock in a company you are actually hiring management to manage your money. If they do poorly why not make the same decision you did in your business. . . fire

them (sell the stock)? You see, there are no good or bad companies, only good management or bad management. In most sectors if you show me a company that is doing poorly, I can show you a company (in the same business) that is prospering.

Investors seem quite willing to sell at a profit (firing good management) but are reluctant to sell at a loss thereby retaining poor management. In fact, most investors just neglect their responsibility of reviewing their investments. I frequently do portfolio analysis for potential clients. It is quite an eye opener to see a printout of exactly what is really happening. I use VisiCalc which is the best program I have ever seen and is a snap to use. For those who don't have VisiCalc I sat down for a few hours and wrote the Program Listing.

I included a random portfolio generator with which you can have some fun. See Fig. 1. Run the program and see how well you have done. I ran out of horizontal space or I would have included two more variables. . . how long you have owned a security and the average yearly return. That should be easy to figure long hand. Some of the stocks you have held for ten years will be exposed as having been very poor investments considering the dollars they sell for today will buy 30 percent of what the dollars you paid for them would buy! ■

Editors note: If you have a special investment question, you may write to the author c/o 80 Microcomputing. I promise a prompt personal answer.

SECURITY NAME	SHARES	COST	CURRENT	P/L	DIV.	% RETURN
CRISLER	4	45	27.0	-72	1.49	5.51
WAYNE GREEN INC.	223	12.2	21.6	2087	1.16	5.36
80 US	2	2.75	3.3	1	0.10	3.08
DINGBAT COMPUTER	498	6	4.0	-996	1.81	45.33
DOS MINUS	40	23	25.0	80	1.78	7.10
E.F. MUTTON	436	21	24.0	1308	1.07	4.47
MERRELL CINCH	135	26	3.0	-3105	1.00	33.50
SCHEME WITTER	479	43	24.0	-9101	1.95	8.14
PAINE ROBBER	378	39	48.0	3402	1.91	3.98
CRAP APPLE	366	16	10.0	-2196	1.80	17.97

PORTFOLIO VALUE = \$52083
 TOTAL YEARLY RETURN = \$4157
 PERCENTAGE RETURN ON CURRENT VALUE = 7.98
 TOTAL PORTFOLIO HAS A CUMULATIVE LOSS OF \$591.72

Figure 1

ANNOUNCING! SOFTWARE SYNTHESIZER! ANNOUNCING!

K AND K INTRODUCES A SOFTWARE BREAKTHROUGH FOR TRS-80'S* IN SYNTHESIZED MUSIC PRODUCTION. AT THE AFFORDABLE PRICE OF \$4.95 YOU CAN LEARN ABOUT AND CREATE YOUR OWN ELECTRONIC MUSIC.

YOU CAN SELECT FROM MANY SOUND TYPES AND CONTROL MANY PARAMETERS. COMBINED WITH THE UNDERSTANDABLE MANUAL AND MANY EXAMPLES THIS PACKAGE IS A MUST.

K AND K COMPUTER PERIPHERALS
 P.O. BOX 88203 DEPT 1111
 KENTWOOD MI 43008-9203
 PLEASE ADD 1.00 FOR SHIPPING

*TRS 80 IS A TRADEMARK OF TANDY CORP.

354

FOR THE NO-DISK 5-80 MOD I/III

KWIK

THE REASONABLE ALTERNATIVE TO DISK

NOT JUST A SIMPLE SPEED-UP, BUT THE EASY-TO-USE AND RELIABLE KWIK CASSETTE OPERATING SYSTEM THAT UPDATES YOUR CTR USING KWICOS TO SAVE AND LOAD YOUR PROGRAMS GIVES YOU THESE ADVANTAGES:

- Write, Read, Verify, Search, Test-Read, and Catalog of both BASIC and machine code programs.
- 2x to 8x speed for Mod I, 2250 baud for Mod III.
- MERGE command to chain-load programs from tape.
- CSAVE, CLOAD, and SYSTEM still useable. Load at 500 baud, save with KWICOS, and vice-versa.
- No "lock-up" or garbage-loads from a bad tape.
- Active BREAK key during cassette operations.
- Program files can be up to 32 characters long.
- You can password-protect any KWIKOS program.
- Motor on by keyboard-protect any KWIKOS program.
- Built-in BACKUP feature lets you copy BREAK.
- Adjustable debounce and BASIC execution speed.
- Display of program length on each save or load.
- Mod-I: Fully compatible with LemonAid Loader.
- Mod-III: Command control of BREAK key, cassette high/low, I/O routing, I/O reset, clock set, date set, and clock display on/off.

SMILE when you say TAFE!
 Cassettes for 4k-48k
 Level II only
 (Specify Mod I-III)

\$24 ppd

KWIK Software
 P.O. Box 328
 Boiliver, MO. 65613

359

© TM of Lemon's TAFE Services

DOTPLOT-80 HI RESOLUTION GRAPHICS SOFTWARE

USE YOUR LINE PRINTER VII OR LINE PRINTER VIII TO DRAW:

- ★ COMPUTER ART
- ★ LINE DRAWINGS
- ★ GRAPHS WITH FULL LABELING

RESOLUTION:

- ★ 60 DOTS/INCH HORIZONTAL
- ★ 63 DOTS/INCH VERTICAL

SAMPLE PROGRAMS INCLUDED.

MODEL I OR III, CASSETTE	LEVEL II BASIC \$19.95
-----------------------------	---------------------------

PLEASE SPECIFY 16K, 32K, OR 48K
 OHIO RESIDENTS ADD 6% SALES TAX

WORKBENCH SOFTWARE
 P.O. BOX 24497
 DAYTON, OHIO 45424

356

PRESERVE

80 microcomputing

**BINDERS
& FILE
CASES**



Keep your issues of 80 Microcomputing together, handy and protected in handsome and durable library files or binders. Both styles bound in dark green leatherette with the magazine logo stamped in gold.

Files: Each file holds 6 issues, spines visible for easy reference, \$5.95 each, 3 for \$17.00, 6 for \$30.00

Binders: Each binder holds 6 issues and opens flat for easy reading, \$7.50 each, 3 for \$21.75, 6 for \$42.00 (Postage paid in USA. Foreign orders include \$2.50 per item)

Please state years, 1980 to 1983

Send check or money order to:

JESSE JONES BOX CORP.

P.O. Box 5120

Philadelphia, PA 19141

Allow 4 to 6 weeks for delivery

EFFECTIVE IMMEDIATELY:

Canadian subscriptions, \$27.97
1 year only, U.S. funds
Foreign surface, \$44.97
1 year only, U.S. funds
Foreign air mail, please inquire.

[All previous subscription
offers void as of
February 1, 1982.]

**this publication
is available in
microform**

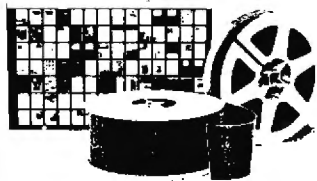

University Microfilms International

300 North Zeeb Road
Dept. P.R.
Ann Arbor, MI 48106
U.S.A.

18 Bedford Row
Dept. P.R.
London, WC1R 4EJ
England

Now...from Dr. David Lien, the master of making the difficult simple, comes the complete way to **HARNESS YOUR TRS-80**

Face it. Until you can talk to and understand your Model I, II, III or 16 Tandy TRS-80*, it's nothing more than a mass of microcircuits in a plastic box.

You need help to harness your TRS-80 and make it work for you. And that's just what you get from *Learning TRS-80 BASIC*.



Written by David Lien, author of the popular *TRS-80 User's Manual for Level I*, *Learning Level II* and *The BASIC Handbook*, *Learning TRS-80 BASIC* is at once entertaining, informative and easy to understand. It's the perfect guide to entering the world of microcomputers.

In *Learning TRS-80 BASIC*, David Lien gives you simple, step-by-step instructions, including programs you can use in business or home finance, for entertainment, or to help troubleshoot problems. You'll even learn to write your own custom software. Ideal for the classroom, too.

Included are short Question and Answer sections which help make sure you understand everything you've learned — it's almost like a correspondence course... without the correspondence!

No matter if you own the Model I, II, III or 16, *Learning TRS-80 BASIC* is one book no TRS-80 owner should be without.

Available at better computer and book stores,

or call (800) 854-6505

In California (714) 588-0996

Ask about the Basic Handbook, too. To order by mail, send check or money order for \$19.95 (California residents add 6%), plus \$1.65 shipping and handling. Overseas orders send \$19.95 plus \$2.50 surface shipping and handling.



CompuSoft® Publishing

1050-E Pioneer Way, Dept. F, El Cajon, CA 92020

✓ 365

*TRS-80 is a registered trademark of the Tandy Corporation.

EDUCATION 80

by Earl R. Savage

"... the paper monster is your ace in the hole."

M*icrocomputers in the Schools* is a collection of 25 articles, papers and reports edited by James L. Thomas. Along with its helpful bibliography and useful appendices it considers such issues as the selection of a microcomputer, hardware and software development, applications in the curriculum (case histories), and trends and issues.

This volume presents a rounded picture of educational uses of micros. Though the various writers express compatible views, their differences of opinion become most apparent when forecasting the future.

My only complaint about *Microcomputers in the Schools* applies to all books and periodicals concerning microcomputers. The simple fact is new developments affecting the power of these machines take place so rapidly that anything in print may be behind the times. But then, in the computer field we are accustomed to this and make mental updates as we read.

Altogether, *Microcomputers in the Schools* presents plenty of useful and interesting ideas and information. It is primarily practical rather than theoretical in approach. If you cannot find a copy locally, contact the Oryx Press, 2214 N. Central at Encanto, #106, Phoenix, AZ 85004.

The Administration and Computers

For almost two years this column has discussed a variety of educational computer applications. Looking back, one important area has received little attention.

Now that the end of the academic year is just around the corner, a look at the potential of computers in school administration is needed.

There are at least two good reasons teachers should take an interest in this topic. Instruction cannot take place in a vacuum. Classrooms, materials and supplies, salaries, heat, custodians, textbooks, buses and a whole list of things are needed to make instruction possible today. The provision of such materials is the province of the administration.

Anything which increases the effectiveness and efficiency of school administration also increases the *potential* of the instructional program. Administration, like instruction, has grown in complexity;

legal and regulatory requirements have increased almost beyond reason. Consequently, computers are needed as much in school offices as they are in the classrooms.

When a computer provides an administrator with more, better and quicker information and service, classroom teachers benefit both directly and indirectly. Furthermore, the administrator who uses a computer is more likely to see the advantages for having one in the classroom.

Being reasonably objective about the question, I suggest that teachers who want computers for CAI should be equally aggressive about *selling* the computer to the administration.

To sell anything to anyone, you must have a minimum of two things: knowledge of your product and a passable knowledge of the client's operations. Let's assume you know the microcomputer's potential. If you don't have a fairly good grasp of office and business applications, read business and application articles in past issues of *80 Micro*. It isn't necessary you completely understand the applications—just what is possible.

The second factor, knowledge of school office operations, may be a bit more difficult to acquire. Here, again, you don't need to know the details, just have a feeling for the types of tasks and their magnitudes. If you have been teaching more than a year or two, you probably have a good start on this.

At times everyone feels inundated with clerical work. We are in a data-using, record-keeping business. Even your principal suffers from the paperwork syndrome, an affliction affecting all educators more severely with each passing year. It will not lessen or remain constant; the paper monster can only continue to grow as local, state and federal demands increase.

If you accept the premise that a computer-using principal will be more receptive about CAI, the paper monster is your ace in the hole. Attack your principal where he is most vulnerable—show how a microcomputer can reduce paperwork in his office and, at the same time, provide more usable information.

Table 1 will assist you in planning your attack. A broad spectrum of administrative tasks can be accomplished more efficiently and effectively using a computer. This is *not* an exhaustive list; it is just a topical outline. You will have to supply the details.

Potential Applications

Non-users are notoriously unable to see the potential applications of a computer (every good salesman knows this). Your principal will not understand, at first, that the list of students and their homeroom assignments can be typed into the computer *once* and used in a dozen different ways in other programs.

Begin by giving the principal a break-

Financial

- Accounts Receivable
- Accounts Payable
- Payroll
- Student Activity Accounts
- Budgeting

Pupil Accounting

- Daily, Monthly, Yearly Attendance Records and Reports
- Daily Absentee List
- Student Directories
- Report Cards
- Grade Distribution Studies
- Student Records

Word Processing

- General Correspondence
- Personalized Form Letters
- Reports
- Curriculum Guides
- Newsletters, Bulletins
- Handbooks, Manuals

Personnel Accounting

- Records, Reports
- Directory

Miscellaneous

- Inventories (textbooks, supplies, equipment)
- Mailing Lists, Labels
- Activity Calendar
- Room Utilization
- Energy Utilization

Table 1.
Selected Administrative Applications

down on one application (for example, pupil accounting; specifically, attendance). Absentees may be entered daily or weekly. Based on a file of all students in the school, the computer can produce the information listed in Table 2. Point out that these items are often needed but are not always available because they take too much personnel time to prepare.

Ask your principal how often he receives a detailed grade distribution study and report. How many times does his

secretary type the same letter over and over with different student/parent names? How many hours does he and his bookkeeper spend on the calculator working on the annual budget? How many days are spent reconciling bank balances and the myriad student activity accounts?

It is important to stress not only the savings in time and effort but all the additional information at his fingertips with just the touch of a couple of keys.

When the conversation strays to other

areas (as it surely will), here are a couple of additional lists to help you formulate responses. Table 3 lists some specialized school departments for which a computer can do clerical work. The uses shown are but the tip of a very large iceberg.

Table 4 provides a list of some of the clerical applications for the classroom, included primarily to be sure you have not overlooked any major areas of use. (I am reminded of the teacher who asked a new colleague what he would do all day if he did not have the students copying notes from the chalkboard. The quiet answer was, "I'll do what I'm paid to do—teach.")

Let's consider the strategy more carefully. First: Don't hit the principal with all this at one time. Go easy, not because he deserves great sympathy, but because he won't be able to *absorb* all the information in one serving. Your objective is to sell, not to overwhelm.

The second point to consider is to avoid creating unreasonable expectations. Tell him repeatedly that the changeover must be orderly and slow if it is to be successful.

Third: Don't let him assume that one computer can do all the things you have been telling him about.

My final piece of advice is to get some assistance. Find a knowledgeable colleague or two to reinforce your efforts. Suggest a visit to a school where a computer does a lot of the office work and provide literature of a general nature. As an example of the latter, you may be able to get a copy of the book mentioned above. In the meantime—good luck! ■

- Daily absentee list
- Daily list of students with cumulative absences greater than xx days
- Daily list of students with consecutive absences greater than yy days
- Letters to parents of either/both groups of students identified above
- Monthly (or other) teachers' "registers" (or whatever the local official record may be called)
- Monthly principal's attendance report
- Annual principal's attendance report
- As needed:
 - Updated class roles
 - List of students withdrawn to date
 - List of students enrolled since fall

Note That None of the Above Require Manual Computations

Table 2. Some Possible Outputs From Daily Entry of Student Absences

Cafeteria

- Time Keeping
- Bookkeeping
- Payroll
- Inventory
- Reports
- Personnel Records

Library

- Accession Records
- Shelf List
- Card Catalog
- Inventory
- Utilization Records
- Reports
- A V Schedule, Records, Reports

Guidance

- College Selection Assistance (admission requirements and programs available)
- Class Standing
- Student Records
- Transcripts
- Test Statistics and Studies
- Student Schedules
- Correspondence and Reports

Student Publications

- Newspaper
- Magazine
- Yearbook

Athletics

- Inventories
- Schedules
- Individual and Team Statistics
- Analysis of Scouting Reports

Table 3. Quasi-Administrative Applications

Test Making

- Test Item Bank
- Test Printing from Selected Items

Evaluating/Reporting

- Test Score Analysis
- Competency Analysis
- Grade Averaging
- Grade Distributions
- Parent Reports—Progress
- Deficiencies
- Grade Summaries at any Time
- Grade Book

Word Processing

- Study Materials
- Course Outlines
- Reports

Miscellaneous

- Monitor Student Progress
- Test Individual Students
- Pupil Accounting (if not incorporated at the school level)

Table 4. Selected Teacher Clerical Applications

Copernica Mathematica

by Bruce Douglass

"If you know how something is changing, can you determine what it is doing right now?"

In February we discussed the basics of differential calculus. We introduced the ideas of a limit (an infinitesimally small increment (dx)) and the derivative of a function.

Now let's consider the integral—it is just the opposite of a derivative. That is, if you find the integral of $g(x)dx$, you are finding the function $f(x)$ such that its derivative is $g(x)$, or $f'(x)$ equals $g(x)$. That is why the integral is sometimes called the antiderivative.

Usually, the integral is introduced either as an antiderivative or as a means of finding the area under a function. It may not be obvious that these are really the same thing. Let's explore the integral as a means of finding the area under a curve.

One Approach

Let $f(x)$ be the curve shown in Fig. 1; $f(x)$ is a function of x . The curve is a plot of $f(x)$ versus x . It shows the values of the function $f(x)$ with its corresponding x values.

Now dx is a very, very small change in x ; we can let df be the correspondingly small change in $f(x)$. The derivative of the function with respect to x is df/dx or $f'(x)$, which we'll call $g(x)$ for now. The product $f'(x)dx$ corresponds to the area shown in Fig. 2 (with dx and g blown up in size). In Fig. 2, we have $g(x)$ versus x , rather than $f(x)$ versus x . What is the geometric interpretation of $g(x)dx$? Remember, the area of a rectangle is equal to the product of the length of two adjacent sides. For the rather narrow rectangle shown in Fig. 2, $g(x)$ is the height and dx is the width. So their product is that rectangle.

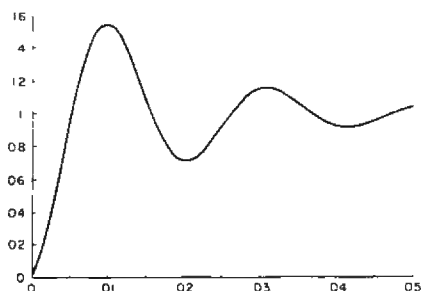

Figure 1

If we divide all the area under the $g(x)$ curve into such small rectangles and add them up, we have the area under that curve. Notice that since we actually showed a relatively big dx , we only have an approximation of that area. As the value of dx gets smaller and smaller (which gives more and more rectangles to add), we approach the true area under the curve. This is shown in Fig. 3. When we get to the smallest value dx could be and still be greater than zero (here dx is said to be "infinitesimally small"), then adding up all these rectangles (there is now an infinite number of them, each with a very small area), we get the exact area under the curve.

That is what an integral is. The symbol \int is actually an elongated S, indicating a sum. The integral of $g(x)dx$ is the area under the curve. Note that we did this between two limits; that is, we performed this summation starting at x equals a and ending at x equals b . This is a definite integral, because we assigned definite limits to it (shown by putting a at the low end and b at the high end of the integral sign: \int_a^b).

Now, let's show the equivalence of the two definitions of the integral given at first. We defined $g(x)$ to equal $f'(x)$. Since $f'(x)$ equals $df(x)/dx$, the product we integrated, $g(x) dx$, equals $df(x)$. If we add these from x equals a to x equals b , we get the infinite sum:

$$\begin{aligned} & ((a+z) - f(a)) + ((a+2z) - f(a+z)) \\ & ((a+3z) - f(a+2z)) + \dots + \\ & ((b-z) - f(b-2z)) + \\ & ((b) - f(b-z)) \end{aligned}$$

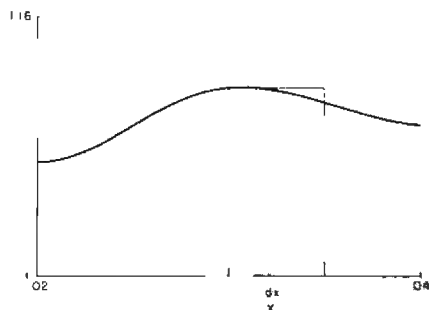

Figure 2

Two things should be understood here. Since $df(x)$ is a small increment of $f(x)$, it is the difference of $f(x+z)$ minus $f(x)$, where z is a very small increment equal to dx . The sum of all of these increments equals the integral of $g(x)dx$. Note that all the terms cancel out, except the two endpoints which only appear once. Thus, the integral of $f'(x)dx$ from a to b equals $f(b)$ minus $f(a)$. This is so important in calculus that it is called the *Fundamental Theorem of Calculus*. It appears in mathematical notation below:

$$\int_a^b f'(x)dx = f(b) - f(a)$$

To reiterate, we have just shown that the area under the curve $g(x)$ between the limits of a and b equals the difference in the value of $f(b)$ minus $f(a)$, provided that $g(x)$ equals $f'(x)$.

Another Approach

Now, let's approach integration from the other view. If you know how something is changing, can you determine what it is doing right now? For example, if you drop a ball (we won't deal with air resistance here), you know it actually accelerates towards the ground. Not only does it fall, but it falls faster and faster as time goes on. The rate of change of the speed (also known as acceleration), is a constant with the respect to the length of time it has been falling. This is the "g" constant you may remember from high school physics. That is, $A(t)$ equals minus g (the minus sign shows that it is falling). Since acceleration is the change in speed with time, the speed must be a function of time. (How fast the object is moving is a function of how long it has been falling.) Further, its position in space relative to where it was dropped from is also a function of time. Can we determine how fast the object is falling and where it is knowing only its acceleration constant? You bet! For now, we'll do it symbolically. If you'll take my word for it, the derivative with respect to x of a constant times x to some power is given by the following relation:

$$d(a \cdot x^n)/dx = a \cdot n \cdot x^{n-1}$$

Get a Letter Quality Printer and a Typewriter, At the Price of a Typewriter.

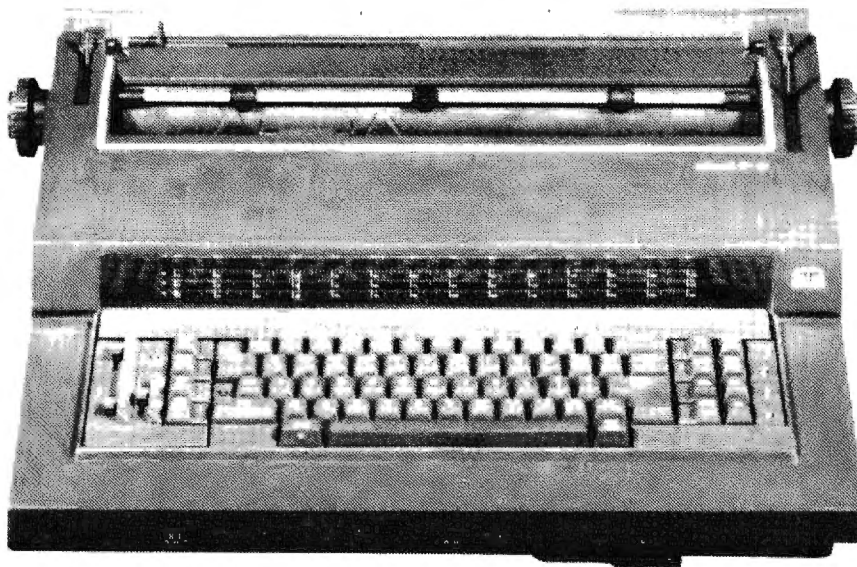

\$1,599.

MTI DOES IT AGAIN. Who but MTI can offer a letter quality printer and an Olivetti electronic typewriter in one unit, at one low price? It's hard to believe.

ITS A LETTER QUALITY PRINTER. At MTI, a low price is not enough unless we can also deliver a superior printing quality. From this interchangeable Daisy Wheel printer. You get clear and crisp print characters and the outstanding features you need. Like:

- *Speed .17 c.p.s
- *Print capability in 10 pitch pica, 12 pitch elite, and 15 pitch mikron.
- *100 character set with upper, lower case and underlining.
- *33 different typetypes.

This printer/typewriter has a printing line length of 13.2" and will take paper up to 17" wide. Perfect for business quality reports and documents

ITS AN ELECTRONIC TYPEWRITER. This Olivetti typewriter makes correspondence and other work simplified. By means of it's logic, it automates those functions that were traditionally done manually by a secretary. Margin Setting, numerical alignment, table formatting and other functions are done rapid and simple operations.

EASY CORRECTION. One-line memory enables words or sentences on the line in process to be automatically cancelled, by the touch of a key.

READY TO GO. You can put this unit to work the minute it's delivered. Everything you need for both functions is included. The unit is complete with parallel interface. It's compatible with TRS-80, Apple, our M.T.I MOD III computers and nearly all others made. All units are backed by the M.T.I. warranty. The result is outstanding performance, great reliability, and a price you can afford.

OPTIONS. You can add on a RS-232 Serial Interface. Tractor feed is also available. Note: Cable extra.

WANT MORE? For more information, call any of our authorized sales and service centers listed below. If you prefer, you can call or write us and we'll send you the information and a free catalog.

MTI AUTHORIZED SALES AND SERVICE CENTERS

Anchorage, AK (907) 333-8322
 Rodgers, AR (501) 636-9188
 Mesa, AZ (602) 833-8949
 Phoenix, AZ (602) 244-9739
 Sierra Vista, AZ (602) 458-2479
 Tucson, AZ (602) 323-9391
 Anaheim, CA (714) 773-0240
 Covina, CA (213) 332-4088
 Goleta, CA (805) 967-7628
 Huntington Beach, CA (714) 842-1348
 Inglewood, CA (213) 673-3295
 Lancaster, CA (805) 942-5747
 Montclair, CA (714) 626-4813
 Northridge, CA (213) 886-9200
 Orange, CA (714) 771-0880
 Pacheco, CA (415) 689-2260
 Placerville, CA (916) 622-4640
 Port Huememe, CA (805) 985-2329

Redondo Beach, CA (213) 370-5556
 Riverside, CA (714) 781-6361
 San Diego, CA (714) 275-4243
 San Jose, CA (408) 946-1265
 Santa Ana, CA (714) 850-1228
 Santa Monica, CA (213) 393-5785
 Vallejo, CA (707) 554-4933
 Walnut, CA (714) 594-9760
 Westlake Village, CA (213) 706-0333
 Colorado Spring, CO (303) 630-3334
 Grand Junction, CO (303) 434-3616
 Groton, CT (203) 445-5166
 Wilmington, DE (302) 762-0227
 Hollywood, FL (305) 981-1011
 Lynn Haven, FL (904) 265-8452
 Mary Esther, FL (904) 243-5793
 Tampa, FL (813) 247-6023
 Norcross, GA (404) 449-8982

Buckingham, IA (319) 478-2826
 Belleville, IL (618) 277-2354
 Collinsville, IL (618) 345-5068
 Oak Park, IL (312) 386-3323
 Shawnee, KS (913) 631-2029
 Ashland, KY (606) 325-2210
 Shreveport, LA (318) 865-7189
 Anoka, MN (612) 427-5783
 Cameron, MO (816) 632-6528
 Great Falls, MT (406) 737-0901
 Missoula, MT (406) 549-9715
 Raleigh, NC (919) 755-1175
 Grand Forks, ND (701) 772-7848
 West Milford, NJ (201) 728-8080
 Las Vegas, NV (702) 870-4138
 Jericho, NY (516) 333-2266
 New Rochelle, NY (914) 235-4444
 Syracuse, NY (315) 467-5000

Troy, NY (518) 273-8411
 White Plains, NY (914) 761-9283
 Tonkawa, OK (405) 628-2693
 Tulsa, OK (918) 836-9503
 Portland, OR (503) 281-7640
 Dallas, TX (214) 247-6679
 Missouri City, TX (713) 499-5241
 San Angelo, TX (915) 658-3781
 Cheyenne, WY (307) 632-9132
 Buenos Aires, ARG 32-1858
 Paris, FRANCE 306-4606
 Holm, GERMANY 4103-4315
 Florence, ITALY 55-45-4319
 Singapore, JAPAN 220-7182
 Cape Town, S.AFRICA 2145-1047
 Tahiti, F.P. 2-54-47
 Taichung, TAIWAN 4228-5523
 Bang Kok, THAILAND 314-1161



MICROCOMPUTER TECHNOLOGY INC.
 3304 W. MACARTHUR, SANTA ANA, CA 92704
 (714) 979-9923 • TWX 910-595-1902 MTISNA

Call or write for free brochure:
 U.S. PRICES, F.O.B. SANTA ANA
 CALIFORNIA AND MAY VARY BY AREA

248

The derivative of a constant is zero (it doesn't change). Now, since the integral is an "antiderivative," the integral of $a \cdot x^b$ must be

$$\frac{a}{(b+1)} \cdot x^{(b+1)} + c$$

(Verify this by taking the derivative of the result.) Also, since acceleration is the rate of change of the speed, the integral of the acceleration must be equal to the speed (by the Fundamental Theorem of Calculus). Since we know experimentally that the acceleration of a falling body is a constant (g), speed must be a linear function of the time spent falling. That is, $S(t)$ equals $g \cdot t + a$, where a is the integration constant. We include it because we don't know if a constant was lost in the original differentiation (the derivative of a constant is zero). It may turn out to equal zero later. Now, we can use our rule again to integrate $S(t)$ to get the position as a function of time, $P(t)$. See if you can do it yourself...

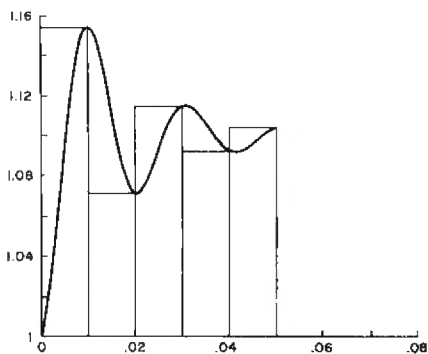

Figure 3

That's right, it is $P(t)$ equals $(g/2) \cdot t^2 + a \cdot t + b$. Notice we had to add another integration constant, b . We get the values of the integration constants by knowing the value of the function at some points. We can do all this numerically as well. Not all functions can be so simply integrated; however, a wide range of functions can be integrated symbolically using these and many more symbolic integration rules.

Analytically, integration is generally much more difficult to perform than differentiation. Many functions do not have an integral that can be expressed in terms of elementary functions. For example, the integral of $(1/x)$ produces the logarithm. Many other integrals, such as the integral of the Gaussian error function ($\exp(-x^2)$) also may not be expressed as simple functions. If this is the case, the function is said to lack a closed-form solution. Integration of such functions requires numerical methods. This is particularly true in differential equations, a topic we will take up some other time.

For now, let's develop programs to find the integrals of some functions. An obvious approach would be to use the same algorithm I presented for the integral earlier: Take small increments in x across the interval, find the corresponding $f(x)$ values, and add up the products. This is the simplest algorithm known and one of the least accurate. It is demonstrated in Fig. 3.

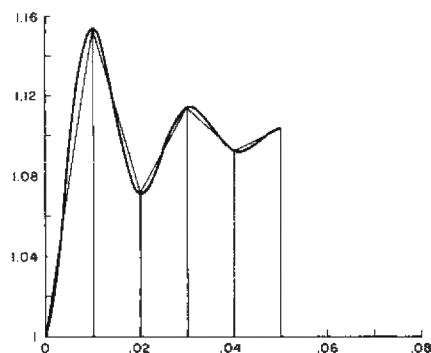

Figure 4

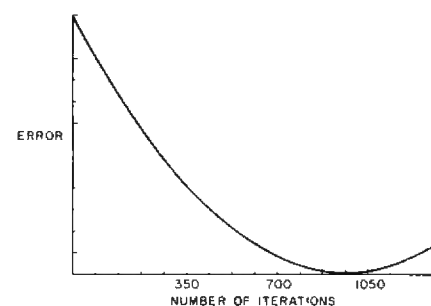

Figure 5

You can easily see the reason for the inaccuracy. We can add all those rectangles, but look at how far off we are using the rectangles as an approximation! We can use smaller increments and add up more rectangles to improve our accuracy — to a point. If we keep taking smaller increments and summing up the areas of more rectangles, we do decrease the error of our approximation. This is shown in Fig. 5. But notice that for single precision, the error bottoms out at about 1000 rectangles and then begins to climb again. Why?

Every time we represent a number, add, subtract, multiply or divide, some error is introduced. If we don't perform too many operations that add up (or propagate) error, we can usually get by. But if we find and add the areas of so many rectangles, eventually we no longer gain accuracy by finding smaller rectangles. Error increases beyond this point due to propagated round-off error. Double precision postpones this somewhat, but no matter what precision you use, eventually round-off error becomes a problem.

What Are You Going To Do?

You could look for a better approximation. The next approximation is called the trapezoid rule shown in Fig. 4. Instead of the flat "head" that we found in the previous rectangular approximation method, we have sloped ones. These are called trapezoids. Notice that the approximation looks better (it looks more like the true area under the curve). The area of a trapezoid is the same as for a rectangle in the previous example, with a little triangle up above added. The area of each trapezoid would be (using i and j as the values of x on the sides of the trapezoid):

$$f(i) \cdot (j-i) + \frac{1}{2} \cdot (j-i) \cdot (f(j)-f(i))$$

Since $f(j)$ minus $f(i)$ is the height of triangle and j minus i is the base, the area of a triangle equals $\frac{1}{2}$ the base times the height. Note that we can collect terms to get:

$$(f(j) + f(i)) \cdot (j-i) / 2$$

We can now write a program to integrate some function $f(x)$ between two limits a and b , using this trapezoid rule. (See Program Listing 1.)

There are even better methods than the trapezoid rule, such as Simpson's $3/8$ rule. I will develop a more general method of numerical integration that is simple to implement, yet fairly accurate. In fact, the trapezoid rule, Simpson's rule, and other quadrature methods are merely special cases of this general procedure known as the Romberg Algorithm.

The trapezoid rule is sufficient for some purposes, but often it lacks the ac-

FOR MODEL II's ONLY

TIRED OF TYPING IN LENGTHY FIELD STATEMENTS FOR PROGRAMS WHICH ANALYZE PROFILE FILES? WANT TO RESTRUCTURE A PROFILE FILE MOVING ITEMS IN SEGMENT 1 TO SEGMENT 2? YOU NEED FIELDER! YOU MAY NEVER HAVE TO TYPE THE WORDS "FIELD . . . AS . . ." AGAIN. SEND \$5.00* FOR A SAMPLE OUTPUT AND PROGRAM.

*APPLIED TO PURCHASE.

FIELDER . . . \$55.

**SWAYBACK SOFTWARE
BOX 1351
MERCHANTVILLE, NEW JERSEY
08109
609-663-2878**

✓ 391

WHAT DOES 80 MICROCOMPUTING DO FOR YOU?

- IT**
- provides you with more information on your TRS-80* than any other single source
 - gives you 20-30 new programs to use in each of 12 yearly issues
 - reviews equipment and software so you know what or what not to buy
 - gives you the truth about the TRS-80—its good points and its limitations (*80 Microcomputing* is not affiliated with Tandy)
 - lets you save money—lots of it—by comparison shopping within the ad pages
 - clues you in on how other TRS-80 owners are using and updating their systems
 - lets you in on what is really happening in the industry
 - brings you Wayne Green's outspoken and often controversial editorials every month
 - and best of all it gives you a no risk subscription offer —

Subscribe today—if you are not satisfied with the first issue—write "cancel" across your invoice and send it back. The *80 Microcomputing* is yours to keep.



YES I want 80 Microcomputing

- Bill me \$24.97 for a year's subscription
 Bill my AE MC VISA
 Check enclosed

Name _____

Address _____

City _____ State _____ Zip _____

Card # _____ Expire Date _____

Signature _____ Interbank # _____ 325B8

Canadian 1 year only/US funds \$27.97 Foreign Surface 1 year only/US funds \$44.97 (Foreign Air, please inquire.)

80 Microcomputing • PO Box 981 • Farmingdale, N.Y. 11737

*TRS-80 is a trademark of Tandy

curacy required. It does come close to the actual value for the area, but it does so linearly as you increase the number of subintervals. Therefore, it is called a linearly converging or linear method. Other algorithms, such as the Romberg Algorithm, converge much faster. Accuracy increases as the square of the number of subintervals; these are quadratically converging or quadrature methods. Almost two digits of accuracy are added with each iteration using these methods.

The Romberg algorithm produces a triangular array of numbers, each of which is an approximation to the definite integral being evaluated. We will call each element of this array $R(I,J)$. The triangular array produced is:

Romberg Coefficients

R(1,1)					
R(2,1)	R(2,2)				
R(3,1)	R(3,2)	R(3,3)			
⋮	⋮	⋮	⋮		
⋮	⋮	⋮	⋮	⋮	
R(N,1)	R(N,2)	R(N,3)	⋮	⋮	R(N,N)

The first column $R(I,1)$ is actually the coefficients produced by the trapezoid rule. $R(1,1)$ is obtained using only one trapezoid, producing the formula $R(1,1) = \frac{1}{2}(b-a)(f(a) + f(b))$. $R(2,1)$ is obtained using two trapezoids, and so on. In general:

$$R(N,1) = R(N-1,1)/2 + \frac{b-a}{2^N} \left[\sum_{k=1}^{2^{N-1}} \left(f\left(a + \frac{2k-1}{2^N}(b-a)\right) \right) \right]$$

This is actually the formula used to compute the trapezoid rule, although it may appear in a slightly different form. The

```

10 REM      INTEGRATION PROGRAM VIA TRAPEZOID RULE
20 REM      BY ** BRUCE POWEL DOUGLASS **
30 DEF FNY(X)=EXP(SIN(X)) 'FUNCTION TO BE INTEGRATED
40 CLS:PRINTTAB(16);"INTEGRATION BY TRAPEZOID RULE"
50 INPUT"ENTER THE LOWER AND UPPER INTEGRATION LIMITS";A,B
60 INPUT"ENTER THE NUMBER OF INTERVALS";N
70 H=(B-A)/(N-1);FOR I=1 TO N-2
80   SUM = SUM + FNY(A+H*I)
90 NEXT I
100 SUM = SUM * H + (FNY(A)+FNY(B)) * H / 2
110 PRINT"THE VALUES OF THE INTEGRAL IS";SUM
120 END
    
```

Program Listing 1. Trapezoid rule, Basic Version

```

10 REM      ** ROMBERG INTEGRATION PROGRAM **
20 REM      BY BRUCE POWEL DOUGLASS
30 DEF FNY(X)=EXP(-EXP(X)) 'FUNCTION TO BE INTEGRATED
40 DEFINT I-L,N,U
50 CLS:PRINT TAB(16);"ROMBERG INTEGRATION PROGRAM"
60 PRINT:PRINT"1. SINGLE OR 2. DOUBLE PRECISION"
70 AS=INKEY$:IF AS=""THEN70 ELSE P=VAL(AS);IF P=2 THEN DEFDBL R,S,H,A,B
80 PRINT:INPUT"ENTER ORDER OF ITERATION PROCEDURE";N
90 INPUT"ENTER LOWER AND UPPER LIMITS OF INTEGRATION";A,B
100 PRINT"1. DISPLAY INTERMEDIATE RESULTS 2. ONLY END RESULTS"
110 AS=INKEY$:IF AS=""THEN 110 ELSE U=VAL(AS);IF U<1 OR U>2 THEN 110
120 DIM R(N,N) : H=B-A : R(1,1)=H*(FNY(B)+FNY(A))/2 : L=1
130 FOR I=2 TO N : H=H/2
140   L=L+L
150   SUM=0
160   FOR K=1 TO L-1 STEP 2
170     SUM=SUM+FNY(A+H*K)
180   NEXT K
190   R(I,1)=R(I-1,1)/2 + H*SUM
200   IF U=1 THEN PRINT"R";I;",";1;")=";R(I,1);
210   M=1
220   FOR J=2 TO I
230     M=M*4
240     R(I,J)=R(I,J-1)+(R(I,J-1)-R(I-1,J-1))/(M-1)
250     IF U=1 THEN PRINT"R";I;",";J;")=";R(I,J);
260   NEXT J:PRINT
270 NEXT I
280 PRINT"FINAL ANSWER IS ";R(N,N)
290 PRINT"CONVERGENCE WAS ";ABS(R(N,N)-R(N,N-1))
300 END
    
```

Program Listing 2a. Romberg Algorithm, Disk Basic Version

```

10 REM      ** ROMBERG INTEGRATION PROGRAM **
20 REM      ** LEVEL II VERSION **
30 REM      BY BRUCE POWEL DOUGLASS
40 GOTO 70 'BYPASS SUBROUTINE
50 Y = SQR(1-X[2]) 'FUNCTION TO BE INTEGRATED
60 RETURN
70 DEFINT I-L,N,U
80 CLS:PRINT TAB(16);"ROMBERG INTEGRATION PROGRAM"
90 PRINT:PRINT"1. SINGLE OR 2. DOUBLE PRECISION"
100 AS=INKEY$:IF AS=""THEN100 ELSE P=VAL(AS);IF P=2 THEN DEFDBL R,S,H,A,B
110 PRINT:INPUT"ENTER ORDER OF ITERATION PROCEDURE";N
120 INPUT"ENTER LOWER AND UPPER LIMITS OF INTEGRATION";A,B
130 PRINT"1. DISPLAY INTERMEDIATE RESULTS 2. ONLY END RESULTS"
140 AS=INKEY$:IF AS=""THEN 140 ELSE U=VAL(AS);IF U<1 OR U>2 THEN 140
150 DIM R(N,N) : H=B-A : X=B: GOSUB 50 : Y1=Y : X=A : GOSUB 50 :
160 R(1,1)=H*(Y1+Y)/2 : L=1
170 FOR I=2 TO N : H=H/2
180   L=L+L
190   SUM=0
200   FOR K=1 TO L-1 STEP 2
210     X=A+H*K : GOSUB 50: SUM=SUM+Y
220   NEXT K
230   R(I,1)=R(I-1,1)/2 + H*SUM
240   IF U=1 THEN PRINT"R";I;",";1;")=";R(I,1);
250   M=1
260   FOR J=2 TO I
270     M=M*4
280     R(I,J)=R(I,J-1)+(R(I,J-1)-R(I-1,J-1))/(M-1)
290     IF U=1 THEN PRINT"R";I;",";J;")=";R(I,J);
300   NEXT J:PRINT
310 NEXT I
320 PRINT"FINAL ANSWER IS ";R(N,N)
330 PRINT"CONVERGENCE WAS ";ABS(R(N,N)-R(N,N-1))
340 END
    
```

Program Listing 2b. Romberg Algorithm, Level II Basic Version

SEND AND RECEIVE MORSE CODE

- SEND UP TO 40 WPM
- COPY OVER 100 WPM

Your Model I or III becomes a programmable keyboard keyer that can send morse from the keyboard or from stored messages. Keying is done either by the relay or by the audio output. Received morse is decoded, displayed, stored and printed. The cassette sarphone plug connects to the receiver speaker to copy off the air. No hardware except patch cords is required for many setups.

satisfaction guaranteed

Cassette with instruction booklet only \$19.95 postpaid. Model I or III, LEVEL II, with at least 16k required.

ROGO Computer Products
4752 DeBeers Drive
El Paso, Texas 79924 343

$$R(i,1) = \frac{1}{2} R(i-1,1) + h \sum_{R=1}^{2^{i-1}} f(a + (2k-1)h) = \frac{1}{2} R(i-1,1) + h \sum_{R=1}^{2^{i-1}} f(a + (2k-1)h)$$

$$R(i,j) = R(i,j-1) + \frac{1}{4^{j-1}-1} [R(i,j-1) - R(i-1,j-1)]$$

where $h = \frac{2^{i-1}}{(b-a)}$
error is a function of h^*

Table 1. Computational formulas for the Romberg coefficients

Romberg algorithm is a much better algorithm. In general, $R(N,N)$ requires much less computation than $R(2^*N,1)$ and is more accurate. This is true because the error terms from two different approximations of the integral ($R(N,k)$ and $R(N+1,k)$) generate a better approximation to the integral ($R(N+1,k+1)$).

The computational formulas for the Romberg algorithm may appear a bit formidable, but see how short a program can produce the Romberg triangular coefficients. The number of subintervals into which we divide the limits of integration is inversely related to the step size. It shouldn't take too long to convince yourself that the step size, h , equals $(b-a)/2^n$. This is the size of the delta x we are using. The formulas to calculate the new coefficient $R(i,j)$ and $R(i,1)$ appear in Table 1.

This translates into the short programs shown in Program Listings 2a (Disk Basic version), and 2b (Level II Basic version). As written, the programs generate and display all the Romberg coefficients. You may omit the display if you don't care to see them. It might be instructive to see how the numbers converge to the integral.

Applications

There are many applications for numerical integration; I will present only a few here.

First, let's use the Romberg algorithm to estimate the value of pi (π). We know the area of a circle is $\pi * r^2$. If we choose a unit circle, its area should equal π . Let's look at only $\frac{1}{4}$ of the circle, the area in the first quadrant. This is shown in Fig. 6. Note that for each point on the curve in this region, the x and y coordinates are related by the expression y equals $SQR(r^2 \text{ minus } x^2)$; or, since r equals 1, y equals $SQR(1 \text{ minus } x^2)$. You can derive this from the Pythagorean theorem relating the sides of a right triangle. If we let r be the hypotenuse (the long side), and x and y be the other sides, the Pythagorean theorem says 1 equals y^2 plus x^2 . Solving for y yields y equals $SQR(1 \text{ minus } x^2)$. Our job is to find the area under this curve from x equals 0 (the y axis) to x equals 1 (the maximum value for x on the circle). This will be $\frac{1}{4}$ of the total area the circle contains. Multiplied by four, the total area equals the value of pi.

The integral we need to evaluate is $4 \int_0^1 \sqrt{1-x^2} dx$. If you have Disk Basic, use the DEF FN to define the function:

```
30 DEF FNF (X) = 4 * SQR(1 - X^2)
```

If you use the Level II version, use:

```
30 F = 4 * SQR (1 - X^2) : RETURN
```

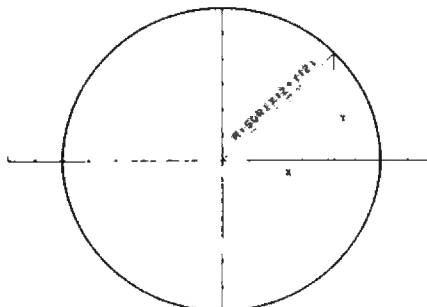

Figure 6

Compare the results obtained with the trapezoid and the Romberg algorithm. Remember that $R(N,1)$ is the trapezoid rule with N subintervals. Run an order 15 approximation (that is, run to $R(15,1)$) and compare $R(7,7)$ with $R(15,1)$. You will find that $R(7,7)$ is more accurate (the value of pi is approximately 3.141592653589793).

Perhaps you would like to know the area between two curves. Figure 7 shows two such curves. What is the area between $F(x)$ and $G(x)$? The area under curve $F(x)$ between a and b is $\int_a^b F(x) dx$ and the area under the curve of $G(x)$ between a and b is $\int_a^b G(x) dx$. The difference of these two areas must be the area between them. To find this area, we just integrate the difference $F(x) - G(x)$ from a to b . For example, if we want to know the area between $f(x) = x^3$ and $g(x) = x^4$ where x varies from 0 to 1, we can use our integration program to generate this. Use the form 30 DEF FN (X) = $x^3 - x^4$ (version 1) or 30 F = $x^3 - x^4$: RETURN (version 2). The actual area is 0.05. How close did you get?

The idea of work done as an integral may be new to you, but it has been around in physics and chemistry for quite some time. Newton's classical physics states that force equals mass times acceleration, or F equals $m * A$. If we apply force for some period of time, we ought to do some work. If the force is constant, then the work done is the force times the displacement (from x equals a to x equals b). This is precisely what we get when we integrate a constant from a to b . If the force is not constant (a more interesting and realistic situation), then the integration becomes more complex.

An example of constant force is gravitational attraction. How much work is done by gravity when you throw a five-pound object straight up 15 feet and gravity pulls it down to earth? Gravity does some work slowing down the object, and then it does some work bringing it back to earth. If you throw it from a height of six feet (since you are standing when you throw it), the work gravity does bringing the object to a halt at 15 feet is $-5 * (15-6)$ equals -45 ft-lbs.

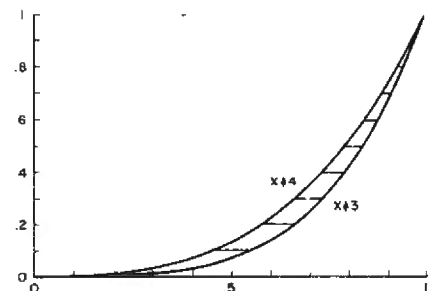

Figure 7

DARK CASTLE GAME SYSTEM for the COLOR COMPUTER

Fully PROGRAMMABLE graphics adventure system. As well as solo adventuring, the two player option allows one player to become the dungeon's lord and direct his creatures. Graphics show moving views of the evil lair and the package allows players to create and save on tape an unlimited number of dungeons --three are included

ALSO

Sir Eggbert Jumper *
Invasion of the Termites *
Alpha Mission *
Wizard

\$12.95 ea. cassette-post pd
16K ext Color Basic

*Joysticks, Req

D. L. Dawson
4808 Davenport. #2
Omaha, NE 68132

✓400

80

microcomputing™

bookshelf

Nanos System REFERENCE CARDS

For Models I, II, III and Color

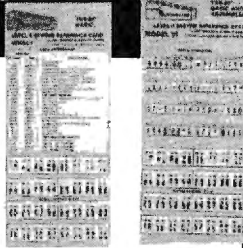

At last! No more flipping through the pages of the Basic manual! No more working through the maze of machine language instructions! These cards completely summarize the Basic and Assembler manuals! **FEATURES** (on most cards): memory map, eyeball graphics, math instructions, basic commands, store instructions, basic functions, load instructions, basic statements, move instructions, special keys, exchange instructions, print using examples, shift instructions, basic special characters, compare instructions, basic and assembler messages and codes, branch instructions, basic facts, data alteration instructions, reserved words, I/O instructions, ROM routines, complete character chart with graphics and space-compression codes, hex-dec chart, control code cross-reference, assembler instructions commands and operators, screen line layout, editor commands & subcommands, condition code easy access

Model I: BASIC only FC1001	\$2.95
Model I: BASIC and Assembler FC1002	\$4.95
Model II: BASIC and Assembler FC1005	\$5.95
Model III: BASIC only FC1004	\$3.95
Model III: BASIC and Assembler FC1003	\$5.95
Color: BASIC and Extended FC1006	\$4.95

NEW!



DOS RANDOM ACCESS & BASIC FILE HANDLING—By H.J. Muller. This book was written for the nonprogrammer. It is ideal for the businessman or professional who needs to solve and write special programs for in-house business problems, or the hobbyist who wants to go beyond the cassette recorder and into disk storage and file manipulation. It is written as a self-instruction tutorial and will provide anyone with some Level II experience with the ability to write special programs for inventories, mailing list, work scheduling, record keeping, research project data manipulation, etc. 150 pages. BK1236 \$29.50

NEW! FOR THE MODEL III

MOD III ROM COMMENTED —Soft-Sector marketing, 1981. This book is not an instruction course on machine language, but rather an information source that you can use time and time again for writing your own program or patching old Mod I machine language programs. It contains an explanation of ROMs in the latest machine from Tandy, with most every location of the 14K ROMs listed, with comments. BK1235 \$22.50.



NOW AVAILABLE FOR THE MODEL III

Nanos System Reference Card
(as described above)

Model III: BASIC FC1004 \$3.95

Model III: BASIC and Assembler FC1003 \$5.95

Prices do not include shipping and handling charges. Please include \$1.50 for first book, \$1.00 each additional book and \$10.00 per book foreign airmail. Sorry no COD orders. Use the order card in this magazine to order. Allow 4-6 for delivery. Shipping and handling for cards only \$1.00 per order.

80 Microcomputing Bookshelf • Peterborough, NH 03458



1-800-258-5473



GEAP

Can You Create Letters Like The Above In 4 Keystrokes . . .

And Have A Word Processor Print Them Just As A Regular Letter Or File? If Not, It's Time To Explore GEAP.

GEAP Stands For Graphics Editor And Programmer.

Depending On Your Hardware & the GEAP Package You Choose, You Can Create Diagrams, Figures, Flyers, Posters, Letterheads And Artwork With Ease.

Using GEAP Does Not Require Basic Programming Knowledge, However We Have Facilities To Allow Programmers To Create Screen Formats And Program Documentation Within Their Programs With Ease.

We Offer GEAP In Modular Form. You Can Get It All At Once Or Purchase It In Pieces As Your Needs Or Hardware Grows.

Graphics Editor And Programmer

FLEXIBILITY, EASE OF USE, AND EASY FUTURE EXPANSION IS WHAT GEAP IS ALL ABOUT.

GEAP Regular Facilities — 16K-48K Disk, Stringy, or Cassette Supported
Simple Commands & Facilities in The Basic GEAP Package:

MODES: Alphanumeric, Graphics, Single Graphic Pixels Can Be Intersued. Free Style Drawing, Create Composites From 2 Or More Drawings, Reverse Graphic Pixels (Selectively), Graphic Block Moves, Graphic Keypad, "Paintbrush", Magnification, Rotation, Save Screen As Basic Program — ASCII Compatible, Compressed, Or String Format

OPTIONAL MODULES & PACKAGES:

MODULE 1 — More rotation, Magnification, & Other Powerful Commands

MODULES 2-4 — Letterist Modules, Instant Letters, No Drawing Required. This Is How We Created The "GEAP" Cube Letters In 4 Keystrokes

MODULE 5 — EPSON Printer Support Module. Now Non-Programmers Can Use The EPSON MX-80 To Print Their GEAP Creations — Posters, Flyers, All With Epson Quality.

GEAP 48K DISK — You Get Module 1-5, & Additional Disk Related Features. Expansion Modules Run Via Menu Selections If You Have The Hardware, This Is The GEAP For You.

NEWSCRIP Support Package — All Of The GEAP 48K DISK Commands, Plus Facilities To Interact With NewScript. Now The Perfect Marriage, Word Processing & Graphics Processing Requires Current NewScript Update.

Regular GEAP	25.99	Expansion Module 1-4	16.99
GEAP 48K	45.99	NewScript 7.0	125.00

(This includes NEWSCRIP Support Package) When Ordering, List System & Peripherals

California Add Sales Tax **J F CONSULTING**
74-355 BUTTWOOD **PALM DESERT, CA. 92260**
(714) 340-5471 273

Epson MX-80 is a trademark of Epson America

NewScript is a trademark of ProSoft

**DISK DRIVE WOES?
PRINTER INTERACTION?
MEMORY LOSS?
ERRATIC OPERATION?**

Don't Blame The Software!



ISO-1

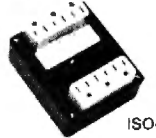

ISO-2

Power Line Spikes, Surges & Hash could be the culprit!

Pat. #4,259,705

Floppies, printers, memory & processor often interact! Our patented ISOLATORS eliminate equipment interaction AND curb damaging Power Line Spikes, Surges and Hash. Guaranteed!

- ISOLATOR (ISO-1) 3 filter isolated 3-prong sockets; integral Surge/Spike Suppression; 1875 W Maximum load, 1 KW load any socket \$69.95
- ISOLATOR (ISO-2) 2 filter isolated 3-prong socket banks; (6 sockets total); integral Spike/Surge Suppression; 1875 W Max load, 1 KW either bank \$69.95
- SUPER ISOLATOR (ISO-3) similar to ISO-1 except double isolation & Suppression \$104.95
- SUPER ISOLATOR (ISO-11) similar to ISO-2 except double isolation & Suppression \$104.95
- MAGNUM ISOLATOR (ISO-17) 4 Quad Isolated sockets; For ULTRA-SENSITIVE Systems \$181.95
- CIRCUIT BREAKER, any model (Add-CB) Add \$9.00
- CKT BRKR/SWITCH/PILOT (-CBS) Add \$17.00

AT YOUR
DEALERS

MasterCard, Visa, American Express
ORDER TOLL FREE 1-800-225-4876
(except AK, HI, PR & Canada)

Electronic Specialists, Inc.

171 South Main Street, Natick, Mass. 01760

Technical & Non-800: 1-617-655-1532

159

```

10 REM ** ROMBERG INTEGRATION PROGRAM **
20 REM BY BRUCE POWEL DOUGLASS
30 DEF FNY(X)=EXP(-X[2]) 'FUNCTION TO BE INTEGRATED
40 DEFINT I=L,N,U
50 CLS:PRINT"EVALUATION OF THE INTEGRAL OF THE GAUSSIAN ERF FUNC
TION
"; TAB(10);"BY THE ROMBERG INTEGRATION PROCEDURE"
60 PRINT
70 DEFDBL R,S,H,A,B
80 DIM R(10,10):N=10
90 FOR U = 1 TO 10: A=-U : B = U
100 H=B-A : R(1,1)=H*(FNY(B)+FNY(A))/2 : L=1
110 FOR I=2 TO N : R=H/2
120 L=L+L
130 SUM=0
140 FOR K=1 TO L-1 STEP 2
150 SUM=SUM+FNY(A+H*K)
160 NEXT K
170 R(I,1)=R(I-1,1)/2 + H*SUM
180 M=1
190 FOR J=2 TO I
200 M=M*4
210 R(I,J)=R(I,J-1)+(R(I,J-1)-R(I-1,J-1))/(M-1)
220 NEXT J
230 NEXT I
240 PRINT"FOR ";A;" TO ";B;" THE ANSWER IS ";R(N,N)
250 NEXT U
260 END
    
```

Program Listing 3a. Tenth-order Romberg approximation, Disk Basic Version.

```

10 REM ** ROMBERG INTEGRATION PROGRAM **
20 REM BY BRUCE POWEL DOUGLASS
30 GOTO 60 'BYPASS FUNCTION SUBROUTINE
40 Y=EXP(-X[2]) 'GAUSSIAN ERF(X) FUNCTION
50 RETURN
60 DEFINT I=L,N,U
70 CLS:PRINT"EVALUATION OF THE INTEGRAL OF THE GAUSSIAN ERF FUNC
TION
"; TAB(10);"BY THE ROMBERG INTEGRATION PROCEDURE"
80 PRINT
90 DEFDBL R,S,H,A,B
100 DIM R(10,10):N=10
110 FOR U = 1 TO 10: A=-U : B = U
120 H=B-A : X=B : GOSUB40 : Y1=Y : X=A : GOSUB40 : R(1,1)=H*(Y1+
Y)/2 : L=1
130 FOR I=2 TO N : H=H/2
140 L=L+L
150 SUM=0
160 FOR K=1 TO L-1 STEP 2 : X=A+H*K : GOSUB40
170 SUM=SUM+Y
180 NEXT K
190 R(I,1)=R(I-1,1)/2 + H*SUM
200 M=1
210 FOR J=2 TO I
220 M=M*4
230 R(I,J)=R(I,J-1)+(R(I,J-1)-R(I-1,J-1))/(M-1)
240 NEXT J
250 NEXT I
260 PRINT"FOR ";A;" TO ";B;" THE ANSWER IS ";R(N,N)
270 NEXT U
280 END
    
```

Program Listing 3b. Tenth-order Romberg approximation, Level II Basic Version.

(Remember that weight is a mass times g , the gravitational constant, and since it points down, you attach a minus sign.) The work done for the falling phase is $-5 \cdot (0-15)$ equals 75 ft-lbs. So overall, gravity did 30 ft-lbs of work.

Suppose the force exerted is proportional to the distance, as it is with a spring (Hooke's law). Then $f(x)$ equals $a \cdot x$, where x is the distance. Let's use our Romberg algorithm to determine the work done in stretching an elastic spring six inches (use $\frac{1}{2}$ foot, so our answer will come out in foot-lbs), if an $8\frac{1}{2}$ lb weight will stretch the spring one inch ($\frac{1}{12}$ feet).

To solve this, we must first determine the proportionality constant in the equation $f(x)$ equals $a \cdot x$. Since 8.5 equals $a \cdot (\frac{1}{12})$, then a equals 102. Our equation now becomes finding the integral of $102 \cdot x$ from x equals 0 to x equals $\frac{1}{2}$. Use the Romberg program to check your answer—it should be 12.75 ft-lbs.

The last example is to find the area under the curve of the Gaussian error

function ($\text{erf}(x)$) from x equals minus infinity to x equals infinity. This function does not have a closed form, as previously stated. The function is defined by $\text{erf}(x)$

$$\text{equals } \int_{-\infty}^{\infty} e^{-x^2} dx. \text{ It is often nor-}$$

malized by multiplying it by the constant $1/\text{SQR}(\text{PI})$. This makes its area equal to one. We will integrate the unnormalized version given above, and it should equal $\text{SQR}(\text{PI})$. Now, how do you integrate numerically from minus infinity to infinity?

The distribution of this function appears in Fig. 8. Notice how small it gets, the further you are away from x equals 0. If you choose a and b far enough away from zero, the area eliminated should not be significant. Since this is a symmetrical function, we will set a equals minus b . We can use our previous Romberg program to write a program that will integrate this function from $-a$ to a , using a given order, say 10. This will take a while to run.

This program will perform a 10th order Romberg approximation of the integral and display it. It will then add one to a and repeat the procedure until you get a equals 10 (starting at a equals one). It will only print $R(10,10)$, rather than all coefficients. Run it. As we get farther away from zero, the relative size of the contribution of the additional area included by expanding a becomes less (we approach the true value for the integral). Now, compare the value of the integral with the true value for $\text{SQR}(\text{PI}), 1.77245385090552$.

Notice that we do not actually approach the value of the integral as we increase the limits to large values. Why? This is because the number of intervals

stays the same, even though the limits get farther apart. Since the function values get smaller and smaller the further you get from zero, the less these areas add to the area under the curve. But since we have taken more total area, and the number of intervals is the same, these areas further out are included in computation of the integral, and the large area around x equals zero is computed less accurately. So, in this case, with a fixed number of intervals, it is not better to take more area under the curve to compute the integral. If we take too small an area, we will be leaving out significant portions of the area under the curve, but if the limits are too far apart, then we lose accuracy where it is needed. In there somewhere are the optimum values for the limits that will yield the most accurate value for the integration. Program Listings 3a and 3b print the 10th order Romberg approximation for the limits of minus one to one up to minus 10 to 10. Compare these with the actual value for $\text{SQR}(\text{PI})$ to determine this optimum.

That about wraps up this introduction. You now understand the basics of differential and integral calculus, although I left out most of what goes into a first-year calculus course. If you are interested in pursuing this, there are many calculus books available you can use to learn more.

If you have any requests for topics you would like covered in this column, drop me a line at my office address:

Bruce Powel Douglass
Dept. of Physiology
School of Medicine
USD
Vermillion, SD 57069

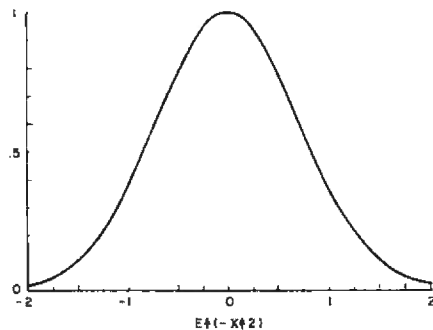

Figure 8

TRS-80* Model III

Hardware & Software at discount prices.

COMPUTER HOUSE

	List Price	OUR PRICE
26-1066 Mod III, 48 K, 2-Disk	2,495.00	2,100.00
26-1062 Mod III, 16 K	999.00	849.00
26-1906 Invasion Force (T)	14.95	11.95
26-1590 Super Scripsel (D)	199.00	155.00
26-1591 Scripsel Dictionary (D)	149.00	119.20
26-1569 Mod III Visicalc (D)	199.00	155.00
26-1592 Profile III Plus	199.00	155.00

ADVENTURE INTERNATIONAL		
Star Trek 3 5 (T)	14.95	11.95
Space Intruders (T)	14.95	11.95
Maxi Manager (D)	99.95	79.95
Star Fighter (T)	24.95	19.95

BIG FIVE SOFTWARE		
Robot Attack (T)	15.95	12.75
Cosmic Fighter (T)	15.95	12.75
Attack Force (T)	15.95	12.75
Super Nova (T)	15.95	12.75

(T) = Cassette Tape (D) = Disk

We represent 20+ mfgs with 300+ programs. Write for our FREE catalog for Mod II, Mod III and Color Computer.

COMPUTER HOUSE

P.O. Box 538 Mammoth Lakes, CA 93546

(714) 934-6538

Orders less than \$100.00 add \$1.50 for postage and handling. Over \$100.00 shipped free. MC & VISA accepted.

*TRS-80 is a trademark of Tandy Corp.

✓ 291

TRISWATCH

Keeps your TRS-80 Mod II up with the times.

The Triswatch, formally known as the CCB-II, is a clock, calendar, and audio alarm rolled into one!

- For TRSDOS users, the CCB-II eliminates the hassle of setting the time and date when you reset your Mod II.
- The P&T CP/M® 2 system date and time are synchronized to the CCB-II each time the system is reset.
- The CCB-II is directly accessible from any language that allows direct port input and output.
- A pacemaker battery is included, which provides over 8 years of continuous timekeeping.

Keep up with the times and order the CCB-II for \$175 plus shipping.



TRS-80 is a trademark of Tandy Corp. CP/M is a registered trademark of Digital Research Inc.

PICKLES & TROUT

P. O. BOX 1206, GOLETA, CA 93116. (805) 685-4641

✓ 290

Warning: Installation requires opening the Model II, which may void its warranty. We suggest waiting until the warranty period has expired before installing the CCB-II.

is HARD COPY STORAGE a problem?



Here's the ideal way to keep your growing collection of 80 Microcomputing in order! The 80 Microcomputing Library Shelf Boxes.

...sturdy, corrugated, white, dust-resistant boxes will keep your issues of 80 Microcomputing orderly and available for constant reference. Self-sticking labels are available for the boxes, too, not only for 80 but also for Kilobaud Microcomputing, 73 Magazine, CQ, QST, Ham Radio, Personal Computing, Interface Age, Byte and Radio Electronics. Ask for whichever labels you want with your box order. Each box holds a full year of the above magazines. Your magazine library is your prime reference. Keep it handy and keep it neat with these strong library shelf boxes. One box (BX1000) is \$2.00, 2-7 boxes (BX1001) are \$1.50 each, and 8 or more boxes (BX1002) are \$1.25 each. Be sure to specify which labels we should send. Shipping and handling charges are \$2.00 per order. Call in your credit card orders on our toll free line 800-258-5473, or use the order card in the back of the magazine and mail to:

ATTN: BOOK SALES

Peterborough, NH 03458

80 microcomputing ^{T.M.}

Please allow 4-6 weeks for delivery. No COD orders accepted.

TRS-80 SO YOUR SCHOOL HAS A MICROCOMPUTER

Basics and Beyond has our software. We offer 70 programs in three packages at less than \$1.15 per program. Microcosm I (30 programs), Microcosm II (20 programs) and Microcosm III (20 programs with sound) contain solid, well documented, educational and enrichment programs for immediate classroom use. Included titles are "Algebraic Factoring", "Planet Finder", "Spelling Bee", "Long Division", "Computer Organ", "Typing Tutor", "Country-Guess", "Math Tables Drill" and 62 more. All can be used on either Model I or Model III with or without disk. Each package comes on two cassettes in a hard cover storage case with a detailed users manual. All programs are original, user-tested, bug free and fully guaranteed. Each package also contains challenging simulations, recreational games and logic-building tests of skill.

See for yourself why Creative Computing called Microcosm I "a worthwhile purchase" and 80-US described it as "exceptional". Microcosm II and Microcosm III are each \$24.95 and Microcosm III is \$29.95. If you're not convinced, write for our free brochure describing each of the 70 programs.

BOX 10 • AMAWALK, N.Y. 10501

BASICS & BEYOND, inc. (914) 962-2355

No charge for postage or handling. N.Y. residents add 5% sales tax. *TRS-80 is a trademark of Radio Shack. Division of Tandy Corp. Master Charge and Visa accepted.

✓ 289

80 CALENDAR

May

- 3-7 Ken Orr and Associates Inc., Topeka, KS. **Course on Structured Systems Design/Structured Requirements Definition**, Tampa, FL.
- 4 University of New Hampshire, Computer Science Department. **Microcomputer Fair**, Memorial Union Building, UNH, Durham, NH.
- 4-7 Integrated Computer Systems, Santa Monica, CA. **Hands-On Pascal Workshop**, San Francisco, CA.
- 4-7 Ken Orr and Associates Inc., Topeka, KS. **Course on Structured Requirements Definition**, Seattle, WA.
- 4-8 University of California Extension, Berkeley. **16-Bit Microprocessor Workshop**, (6 week evening course), Mountain View, CA.
- 6-9 The National Computer Shows, Chestnut Hill, MA. **Southern California Computer Show and Office Equipment Exposition**, L.A. Convention Center, Los Angeles.
- 7-9 The Interface Group, Framingham, MA. **Showcase Expo for small business proprietors, independent neighborhood professionals and mid-level corporate managers**, Anaheim Convention Center, Anaheim, CA.
- 10-14 Ken Orr and Associates Inc., Topeka, KS. **Course on Structured Systems Design/Structured Program Design**, Portland, OR.
- 11-12 The Yankee Group, Cambridge, MA. **The Next Generation of Consumer Electronics seminar**, New York City, NY.
- 11-13 Ken Orr and Associates Inc., Topeka, KS. **Course on Structured Systems Planning**, Washington, DC.
- 11-14 Integrated Computer Systems, Santa Monica, CA. **Distributed Processing, Mini and Microcomputer Implementations**, San Francisco, CA.
- 17-19 Software Design Associates, New York City. **20th User Conference: Productivity in the 80s**, Hyatt Regency Crystal City, Arlington, VA.
- 18-19 The Yankee Group, Cambridge, MA. **The Next Generation of Consumer Electronics seminar**, Palo Alto, CA.
- 18-20 Technical Education Research Centers, Cambridge, MA. **Microcomputers in Education Workshops**, Gutman Library, Cambridge, MA.
- 18-21 Ken Orr and Associates Inc., Topeka, KS. **Course on Structured Requirements Definition**, Kansas City, MO.
- 18-21 Integrated Computer Systems, Santa Monica, CA. **Hands-On Pascal Workshop**, Washington, DC.
- 19 University of California Extension, Berkeley. **The Manager's Approach to 16-Bit Microprocessors**, (one-day intensive course), Mountain View, CA.
- 21-23 The Interface Group, Framingham, MA. **Showcase Expo for small business proprietors, independent neighborhood professionals and mid-level corporate managers**, Commonwealth Pier Exhibition Hall, Boston, MA.
- 22 The New York State Association for Educational Data Systems, Syracuse, NY. **Computer Applications in Special Education**, Mill Neck Lutheran School for the Deaf, Frost Mill Rd., Mill Neck, Long Island, NY.
- 25-28 Ken Orr and Associates Inc., Topeka, KS. **Course on Structured Program Design**, St. Louis, MO.
- 31-4 Virginia Polytechnic Institute and State University. **Personal Microcomputer Interfacing and Scientific Instrument Automation Workshop**, Blackburg, VA.
- 6-8 North Carolina State University. **Sixth Annual Conference on Computers and the Humanities**, Raleigh, NC.
- 7-10 American Federation of Information Processing Societies Inc., Arlington, VA. **1982 National Computer Conference**, Astrohall, Houston, TX.
- 7-9 Technical Education Research Centers, Cambridge, MA. **Microcomputers in Education Workshops**, Taft School, Watertown, CT.
- 7-11 Ken Orr and Associates Inc., Topeka, KS. **Course on Structured Systems Design/Structured Program Design**, Washington, DC.
- 7-11 MUMPS Users Group, Washington, DC. **11th Annual Conference**, Hilton Hotel, Denver, CO.

Coming Next Month

Thinking of turning your TRS-80 into a communications terminal? Next month *80 Micro* looks at electronic bulletin boards, networks and the hardware and software needed to access them.

Frank Derfler, data communications expert and columnist for *Microcomputing* magazine, has written an article that will get the novice started. Frank has recently had a book on data communications published through Prentice-Hall.

Jay Chidsey will have a progress report on the first local electronic newspaper. The *Advertiser-Tribune* of Tiffin, OH, uses a Radio Shack host system to publish its electronic newspaper, which is reportedly up and running.

The British are coming again, but this time it is by satellite. Prestel, the British videotext system, debuted in this country in January. In June *80 Micro* tells you what that means to the home user.

In addition to these features, we will review some great terminal programs and modems. We will also report on some of the popular commercial data bases such as The Source and Dialog.

After reading next month's *80 Micro*, you will know exactly what you can do with your TRS-80 and modem. ■

OPTIONS-80, NOW FOR
APPLE* & TRS-80*

OPTION INVESTING

PROGRAM ANALYSES
RETURN FROM LISTED
STOCK OPTION
INVESTING

HANDLES CALLS, PUTS, SPREADS, IN
AND OUT, COMMISSIONS, RISK, COST
OF MONEY, DIVIDENDS, TABLES AND
GRAPHS, PRINTS, STORES TO DISK,
INDEXED MANUAL A COMPLETE GUIDE
TO OPTION INVESTING, M/C & VISA.
\$125. SEND FOR FREE BROCHURE.
OPTIONS-80, BOX 471
CONCORD, MASS 01742

*TRADEMARK TANDY CORP. *TRADEMARK APPLE COMPUTER, INC.

✓206



PRIZE WINNING CHESS

SFINKS 3.0 (New)

Prize winner in Paris in the 1981 Microcomputer
Chess Championship. Sinks 3.0 is the fastest and
strongest chess program ever written!

FEATURES: Book Openings, Chess Clock, Thinking
on Opponent's Time, Infinite Levels of Play, and
Ruthless Playing Ability!

32K cassette or disk only \$39⁹⁵

SFINKS 1.81

Prize winner in San Jose in the latest (1980) U.S.
Microcomputer Chess Championship. Sinks 1.81
beats Sargon II, Mychess and Gambit 80. Easy to
use with many convenience features.

32K cassette or disk now only \$24⁹⁵

Please specify cassette or disk and Model I or III
✓ 212 INCLUDE \$2.00 SHIPPING AND HANDLING.

WILLIAM A. FINK

(309) 942-5706

P.O. BOX 5912
LIGHTHOUSE POINT, FL 33074-5912

Exceptional Dealer Discounts Available



Data Acquisition and Control for the TRS-80* \$180 ppd.

The STARBUCK-8882 is a complete eight channel
data acquisition and control system, plug
compatible with the Model I Level II TRS-80. It
includes 8 protected analog inputs (0-5 Vdc with
8 ± 1 bit accuracy), 8 protected digital inputs, 8
optoisolated digital outputs, and two joystick
ports. Interrupt-driven software package allows
simultaneous data acquisition and storage while
using the TRS-80 for any other purpose!

Application manual covers home security, energy
monitoring, weather station use, appliance
control, graphics and games. Price includes
case, power supply, extra expansion card edge,
connector cable, complete software package and
detailed applications manual. Manuals only are
available for \$4.00 ppd. Model III version also
available. To order, write:

STARBUCK DATA CO.
P.O. Box 24, Newton, MA 02162

Massachusetts residents add 5% sales tax

*TRS-80 is a trademark of Tandy Corp.

✓205

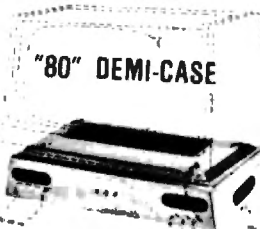

"80" DEMI-CASE

Shown "80" MDX DEMI-CASE

✓174

Encloses LNW & MDX I & II
P.C. Boards, plus
Cabling, A/C Cords, etc.
Silver-gray Fiberglass

\$32.50 plus \$2.50 shipping
N.Y.S. residents add 7% tax

SYRACUSE R&D CENTER
Box 125, Dewitt, N.Y. 13214
"Specializing in Electronic Packaging"



FILE FORCE

A Disk File Program Designed for the Small Businessman

File Force is designed to readily keep track of all your business files
and programs by utilizing all the power of your TRS-80 and Disc
Basic. This program is specially designed to combine the power of a
disk utility, the speed of random access and the ease of use of a
general database manager.

File Force will automatically read the information on your disks and
allow you to search the masterfile by

the name of the disk
the name of a program
the name of a business file
any extension such as a date CMD

✓310

Other special features include easy updating. Where some software
houses have protected their disks to make them unreadable, File
Force will let you assign a disk name and enter those program
names. It will also create a master printout of all business files and
records on your disks for safe keeping and better management of
your resources.

System Requirements: TRS-80 Model I 48K One Disk Drive
TRS-DDS Version 2.3 \$19.95 Please add \$2 for handling and
postage \$5 overseas for your convenience you may phone in VISA
or M/C orders.

SOFTWAREHOUSE INTERNATIONAL

We've Moved! P.O. Box 1383 Tandy Corp
Clovis, CA 93613; (209) 251-7877

4 MHz FOR THE MOD 3

PC BOARD & DOC. ONLY \$19.95

THIS EASY TO INSTALL KIT WILL
DOUBLE THE SPEED OF YOUR MOD-
EL III COMPUTER.

COMPLETE KIT \$59.95

ASSEMBLED & TESTED \$99.95

CALL OR WRITE
J.E.S. GRAPHICS
P.O. BOX 2752
TULSA, OK. 74101

PHONE (918) 742-7104

✓202

B17 TAPE OPERATING SYSTEM will let you

- Save & Load programs 6X faster than Model-1.
- Save & Load Data Arrays over 800X faster.
- Backup standard System tapes that load-n-go.
- Certify cassette tapes for B17 use.

\$24.95 Specify Model 1/3 16K/32K/48K RAM.
Inexpensive Upgrades available. 3rd year of sales.

B17 DISK/BAS is a Disk version. Lets you save any
disk file to cassette at 3000 baud. Inexpensive way
to backup your files. Works with any DOS. Includes
tape certifier. Requires 32K RAM-up.
\$19.95 Specify Model 1/3.

WORDSMITH Word-processing program in BASIC.
A 'Trainer' for more complex W/P programs. Easy-
to-use. Specify Tape/Disk version. Tape version
requires B17 Tape Operating System (above). Disk
version requires 32K RAM-up. Uses MX-80 Printer.
\$19.95 Specify Model 1/3.

Add \$1.00 postage/handling per item.

Write for additional Products Info.

ABS Suppliers
3352 Chelsea Circle
Ann Arbor, MI 48104
(313) 971-1404

✓173



TRS-80* MAGIC

MOD. 1 [IMPROVES LOW SPEED !!! TOO]
— THE AMAZING —

ONLY
\$12⁹⁹
POSTPAID

TAKE THE LOAD OFF YOUR MIND!

Tired of finicky model one cassette loads? You can and
them with the LemonAid Loader. And don't be fooled by its
low price. It uses newly developed signal-active filters that
focus, shape, and size EACH tape pulse. You can often reliably
load "impossible" tapes, and "Possible" tapes load the first
time everytime! And it not only SYSTEM and CLOADs, but it
is fully compatible with software tape speedups and operating
systems like KWICOS** too. And plug a speaker or earphone
into the extra output jack for optional tape monitoring also.

Install the LemonAid in seconds...just plug between CTR
and computer. It needs no power, no software, no rewiring,
no adjustments, and there's no tricky CTR volume settings.
Skeptical? Let us take the risk. Use the LemonAid Loader for
15 days, and then, if you can do without it, return for full
\$12.99 refund, NQA. Order the LemonAid Loader today from:

LEMONS TECH SERVICES
325 N. HWY. 65 P.O. DRAWER 0429
BUFFALO, MO. 65622 (417) 345-7643

* TRS-80 is Trademark Tandy Corp

**KWICOS is Trademark KWIK Software

✓358

™ TRS80 color

From the January 1981 issue of the CSRA Computer
Club newsletter:

There was some amusement at the November
meeting when the Radio Shack repre-
sentatives stated that the software in the
ROM cartridges could not be copied. This
month's 68 Micro Journal reported they had
disassembled the programs on ROM by
covering some of the connector pins with
tape. They promise details next month. Never
tell a hobbyist something can't be done! This
magazine seems to be the only source so far
of technical information on the TRS-80 color
computer. Devoted to SS-50 6800 and
6809 machines up to now, 68 Micro Journal
plans to include the TRS-80 6809 unit in
future issues.

To get the MOST from your 6809 CPU - This is the
BEST SOURCE! The ONLY Magazine for the 6809
Computer. Months Ahead of All Others!

68 MICRO JOURNAL

5900 Cassandra Smith Rd.
Hixson, TN 37343

USA

1 Yr - \$24.50 2 Yr - \$42.50 3 Yr - \$64.50

* Foreign Surface Add \$12 Yr. to USA Price

Foreign Air Mail Add \$35 Yr. to USA Price

*Canada & Mexico Add \$5.50 Yr. to USA Price

✓213

PMC Peripherals \$495

QUALITY, DELIVERY AND SERVICE



Price \$495 for 2

Yes, our disk drive has a proven performance and an established reliability record. We specialize in single sided 5 $\frac{1}{4}$ inch single or double density drives featuring 5 ms stepping and 40 tracks with case and power supply. The case is color matched to IBM and PMC personal computers.

Compare printer specifications . . . compare design reliability, repairability or any other parameter! Our DMP-85 is a true "work-alike" to C. Itoh 8510 or NEC 8023 and offers many more features than the MX-80FT at a lower price. You need excellent printers and a professional supplier. Come to PMC.

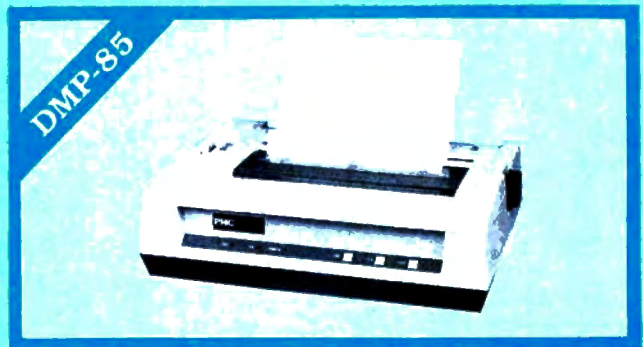

Price \$495

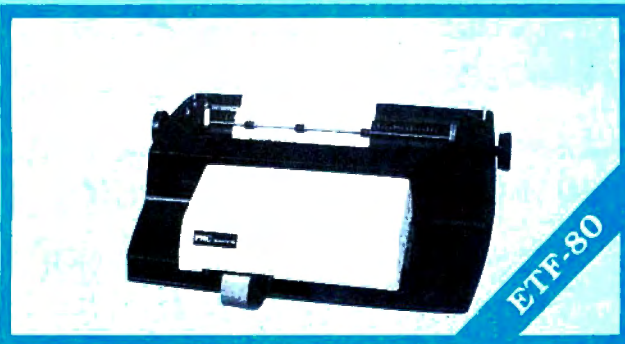

Price \$495

IBM Selectrics or similar typewriters become 12 cps letter-quality printers at a quarter the cost of "daisy wheel" printers. The ETF-80 coupled with a word processor becomes your personal typist accurately reproducing text at 100 wpm. What a bargain, ETF-80 . . . CALL now for details.

PMC peripherals are designed for PMC, IBM, Apple, Radio Shack or other fine personal computers. We don't advertise our unprintable dealer/distributor prices but if you call or write you'll find we don't meet the competition . . . we make it!

PMC Personal Micro Computers, Inc.
475 Ellis Street, Mountain View, CA 94043 (415) 962-0220

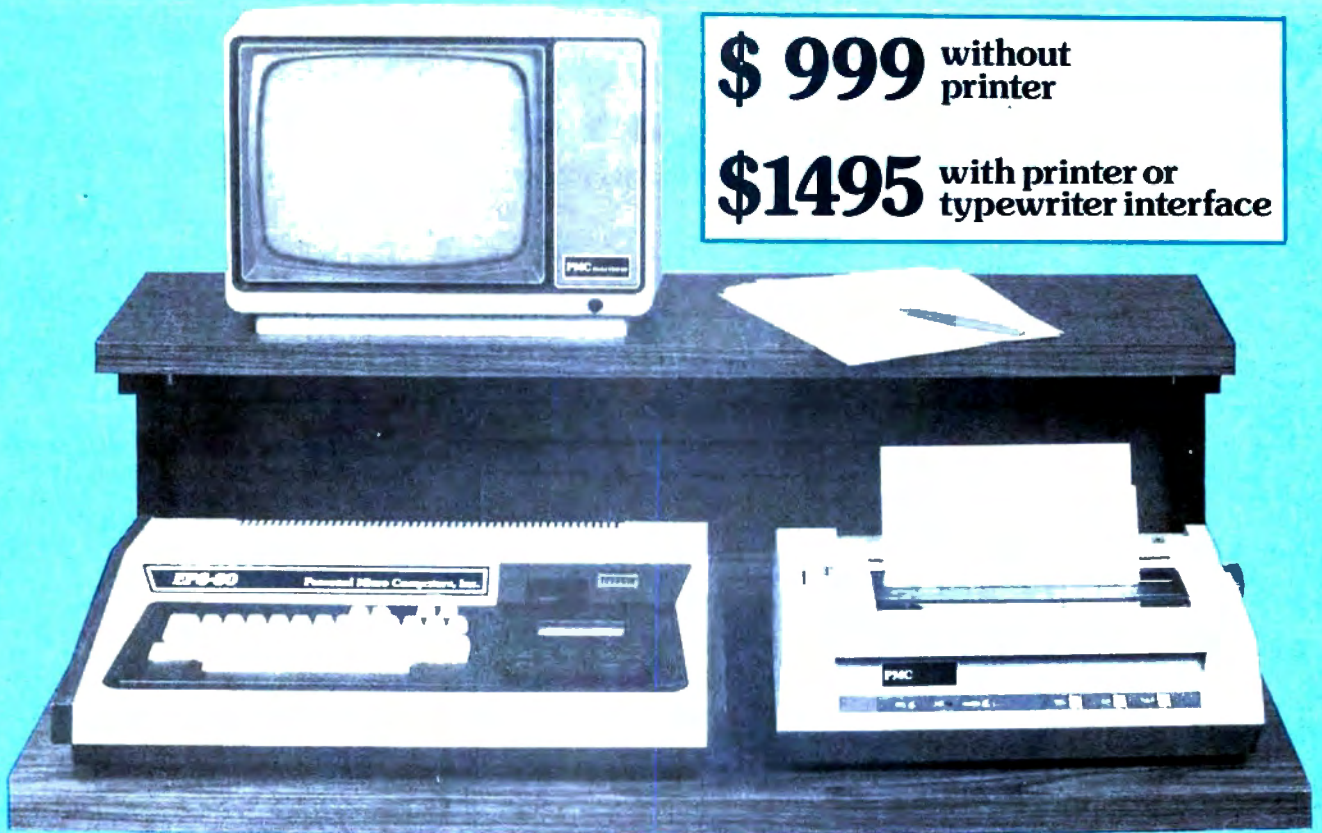

\$ 999 without
printer

\$1495 with printer or
typewriter interface

WORD PROCESSOR Electric Pencil System (EPS-80)

Lowest priced combination word processor/microcomputer that everyone can afford and so simple that anyone can use! The EPS-80 is a word processor designed to replace typewriters as a personal tool and also to be used as a popular personal computer with thousands of programs available.

Use without a printer

In an office environment, the EPS-80 word processor gives the user editing power which is not available in the latest electronic typewriters. The built-in high speed cassette storage achieves inexpensive and reliable transfer of text from one EPS-80 to another. Therefore, where multiple EPS-80s are used, not every one has to have its own printer. For instance, a single letter quality printer on one EPS-80 can prepare final copies of letters for four to ten non-printer stations. The overall system is efficient, costs less per station than an equal number of electronic typewriters, and provides much higher throughput. There is no need for the usual cycle of dictation, correction and proofreading as the basic composing function can be in the hands of the originator.

Use with a printer

Writers, students and businessmen will find the most intelligent investment is the EPS-80. For high speed printing, we offer our model DMP-85 dot matrix printer and for letter quality printing, our Electric Typing Fingers, Model ETF-80, turns your IBM Selectric or similar typewriter into a printer. When you buy the EPS-80, you get both a word processor and a powerful personal computer that will do many necessary tasks. There are fully proven computer programs for invoicing, billing, financial or engineering analysis, spreadsheet calculations, and many more. Even if you never utilize the computer capability, the EPS-80 word processor can provide filing and retrieval of reference information and mail list handling in addition to fulfilling normal typing needs.

How can we offer a product with so much capability at such a low price? It is due to our highly reliable, low cost cassette storage system that performs as well as many floppy disk systems! We believe the EPS-80 is an immediately important tool in small and large offices and it is also destined to be your personal typing friend at home. If you think word processing and low cost computing power would improve the jobs you do, call or write now for complete information.

PMC is licensed to use Electric Pencil, a copyright of Michael Shryer.

PMC Personal Micro Computers, Inc. 242
475 Ellis Street, Mountain View, CA 94043 (415) 962-0220

NEW PRODUCTS

Edited by Janet Fiderio

*Featuring—The K&K Synthesizer
A totally software implemented synthesizer system.*

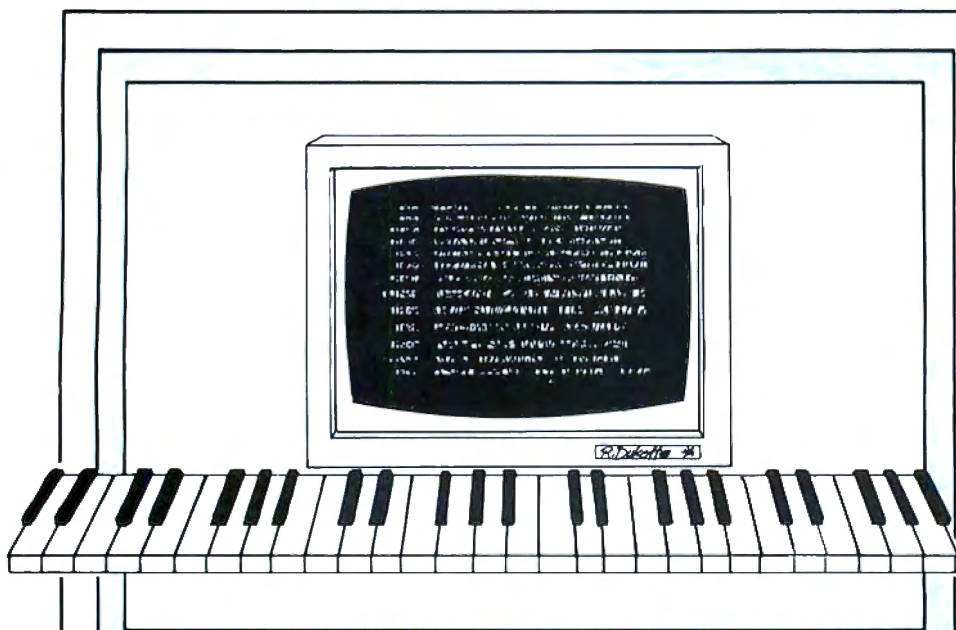

Software Synthesizer

A synthesizer system totally implemented in software is being marketed for the Model I.

The program simulates many features found on hardware synthesizers including white noise, variable frequency cutoff pink noise, frequency and pulse with modulation, variable duty cycle, white noise superimposed on square wave, and full variable glissando. The program also

has limited ability to produce two tones at once.

The operating system has a 300-note buffer with full edit capabilities (copy, insert, delete, change, examine, and makes a progression of notes). It also features full error trapping and many prompts for ease of use.

The synthesizer package is available for \$24.95 from K & K Computer Peripherals, Box 88203, Kentwood, MI 49508-9203.

Reader Service ✓ 562

Property Management

An enhanced version of the disk-based Property Management System for tracking income and expenses on rental property, is now available for the Model I and III, 48K disk system.

The system handles a mixture of property rentals including single-family and multi-family homes, and condominiums. Features of the system include late rental displays, year-to-date, monthly (of all rentals), and total building income can be dis-

played or printed; easy expense entering; operating statements for each building may be printed separately or combined to form a consolidated operating statement for all properties owned.

Check and receipt writing is featured plus complete information on each rental including up to three renter names (or name and address), four phone numbers, date rented, rent amount, deposits, number of returned checks, plus two memo items.

For more detailed information on addi-

tional features of this product contact Realty Software Co., 1116 'F' 8th St., Manhattan Beach, CA 90266, (213) 372-9419. The system is priced at \$375.
Reader Service ✓ 597

New Graphics Editor

Crayon is a 10K, machine-language graphics/text editor for the Models I and III. This screen-oriented editor allows you to typeset your own logos, business cards, letterheads and other business needs. You can also create real-time machine-language cartoons and access them from simple Basic programs.

Crayon capabilities include directories, keeping appointment schedules, writing letters, and helping write Basic program graphics. Over 90 commands allow free movement and manipulation of picture segments on the screen.

Full cassette or disk I/O and manual are provided. Crayon supports MX-80 and other parallel printers. The cassette version costs \$35, the disk version, \$45. Contact Pioneer Software, 1746 NW. 55th Ave. #204, Lauderhill, FL 33313, (305) 739-2071, for information.

Reader Service ✓ 561

Compuvoice and Sound-Source

The Compuvoice Synthesizer (\$44.95) is a completely software-based speech synthesis program allowing you to form words, phrases, and sentences with simple string commands. Compuvoice may be placed into your own Basic programs enhancing their quality with speech synthesis.

Sound-Source (\$24.95) enables you to load any recordable sound into the Color Computer's memory or enter it with a joystick. Once loaded, the data can be played back at a faster or slower rate through the tv sound system. Joysticks enable you to modify or create new data in memory.

Sample sounds for use in games or teaching aids may be easily constructed and tested.

For information contact Spectral Associates, 141 Harvard Ave., Tacoma, WA 98466, (206) 565-8483.

Reader Service ✓ 557

NANSII

NANSII is an information management system compatible with any microcomputer using the CP/M operating system.

NANSII uses English language commands. Some of its unique features include: a learn mode which remembers command streams eliminating repetitive typing; inplace sort capability requiring no additional disk storage; a single disk drive requirement; and an extensive error-detection function which traps 150 types of errors.

A demo package is available for a trial period for a nominal fee. The system retails for \$249.95 and is marketed by XPS Inc., 323 York Rd., Carlisle, PA 17013, (800) 233-7512.

Reader Service ✓ 589.

Pretty Print

Pretty Print provides expanded character enhancements for Epson, Okidata and MPI dot-matrix printers.

This software customization program allows using the sophisticated character enhancements of WordStar (formerly only accomplished by using higher cost daisy-wheel printers.)

Available in standard eight-inch CP/M format and on disk for the Model III from Hurricane Laboratories Inc., Box 631, Cupertino, CA 95015, (408) 446-0777.

Reader Service ✓ 588

The Zapplicator

The Zapplicator contains all current zaps to the NEWDOS80 versions 1.0 or 2.0.

Designed to save time and trouble (and mailing your original disk back to Apparat). The Zapplicator is available for \$13.95 for the Model I and III. All current zaps and a maintenance program to let you add future zaps is available for \$17.95.

For more information contact Micro Pro Systems, Route 2 Box 533, Cumming, GA 30130, (404) 887-6814.

Reader Service ✓ 587.

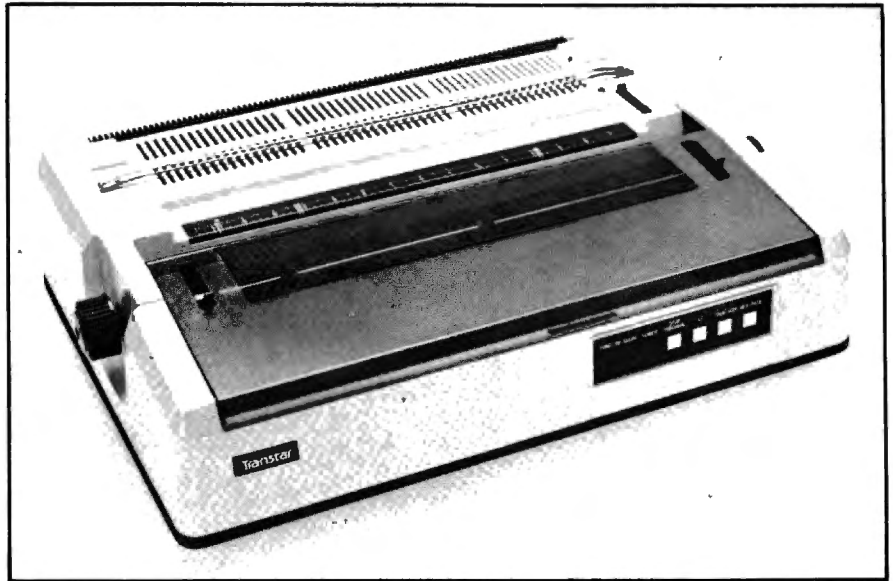

The Transtar 140 daisy-wheel printer

Daisy Wheel Printer

The Transtar 140 daisy-wheel printer combines 40 cps (38 Shannon) letter-quality performance and high reliability.

The serial printer is Diablo (tm) code compatible for plug-and-go use with Magic Wand and Wordstar. Ribbons and print-wheels are also industry standard.

Transtar's low-profile package is only six inches high, and shipping weight is under 50 pounds for UPS delivery.

The printer is available for \$1,695. from Micro Distributors, 11794 Parklawn Drive, Rockville, MD 20852, (800) 638-6621 and Sigma Distributing, 2110-116th Avenue N.E., Bellevue, WA (800) 426-1412.

Reader Service ✓ 598

Coordinated Accounting System

The Coordinated Accounting System includes separate modules for General Ledger (GL), Accounts Payable (AP) and Accounts Receivable (AR). The AR and AP modules print statements and checks on a variety of New England Business Service forms. The system is completely interactive with automatic postings to the General Ledger system.

The minimum system is designed to operate on a three-disk Model I, a two-disk Model III, or a single-disk Model II. The systems can be expanded to use increased disk space. The price (\$200) includes over 200 pages of documentation

and four disks (on the Model I & III) or a single eight-inch disk.

A variety of modules coordinated with the basic system, i.e., Inventory (\$129.95), Job Costing (\$250), Payroll (\$59.95), Order Entry-Invoicing (\$129.95) and Purchase Order Entry (\$129.95) are also available.

Contact D.B. Software Co., 11840 NE Brazee, Portland, OR 97220, (503) 255-7735, for additional information.

Reader Service ✓ 563

Maxprint

Maxprint is a printer-driver utility program developed to allow the Model I or III to use all the features of the standard MX-80 printer. Functions such as underlining, superscripts, subscripts, title centering, proportional justification of the right margin, and dynamic control of line spacing and margins are available.

The program features two main operating modes. A text mode allows the user to select functions on a character by character basis in the body of the text. A menu mode enables the user to achieve printer control in general purpose applications.

Maxprint is composed entirely of Z80 machine language and works with most programs including Scripsit. Source-code listings of all I/O modules are provided for those who wish to modify the program for unique applications.

Maxprint is available for \$27.95 from Peggytronics, 381 First Street, Suite 5147, Los Altos, CA 94022, (408) 737-2253.

Reader Service ✓ 558

NEW PRODUCTS

Model 200 Print Buffer

The Model 200 Print Buffer allows making simultaneous use of your printer and computer. Once the Print Buffer is connected, information to be printed is transferred at high speed from the computer to the Model 200, which then transfers the data at a much slower rate to the printer. The Print Buffer maintains complete control of the printer, thereby freeing the computer to perform other, more intelligent tasks.

This product has a storage capacity of up to 80,000 print characters. To provide additional storage capacity, two or more buffers may be connected together. The Model 200 connects to your computer system using the supplied cable set. Either a parallel or a serial (RS-232C) interface may be used.

Priced at \$545, the unit is available from Modular Microsystems Inc., 28-17 201 Street, Bayside, NY 11360, (212) 352-1715. Reader Service ✓ 566

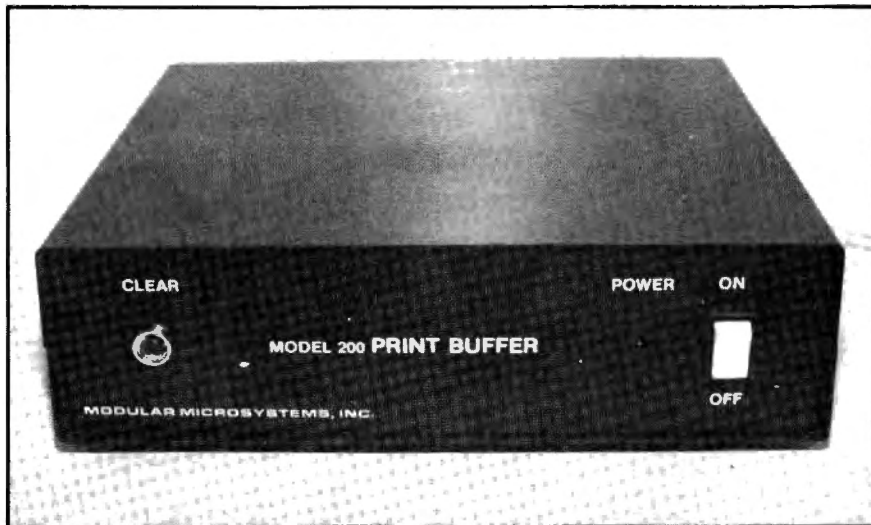

The Model 200 Print Buffer

C.C. Writer for Disk

C.C. Writer, a word processing program, is now available for the Color Computer and Radio Shack or Exatron disk systems.

Disk C.C. Writer retains all of the features of the cassette C.C. Writer and in addition allows full control of the margins, page length, line spacing, centering, justification, and most features of smart printers. Editing features allow changes,

insertions, deletions, and moves anywhere in the text. Files may be chained together for extended printing.

This version requires 32K, Extended Basic, and one Radio Shack or Exatron disk drive. Disk C.C. Writer is \$40 from TransTek, 194 Lockwood, Bloomingdale, IL 60108.

Reader Service ✓ 559

ers in the country, this program is designed to simplify the process of learning Reversi for beginners and sharpen the wits of experts. Master Reversi allows you to play against the computer or another opponent.

This product is available for the Model I with 32K and one disk drive from Instant Software Inc., Peterborough, NH 03458, (603) 924-9471 for \$29.95

Reader Service ✓ 592

Master Reversi

Master Reversi teaches and plays the popular board game and features a tournament mode and built-in help functions.

Written by one of the top Reversi play-

For Inventory Control

INV-X is an inventory control system for the Model II.

Its features include: a built-in sort/merge package; the fastest key access method (a new hashing algorithm); a report writer; a large storage capacity, 6,600 records on the Model II and 28,000 for unlimited disk storage.

INV-X requires a dual-disk system with 64K and TRSDOS. It is priced at \$299. For more detailed information contact The Micro Architect Inc., 96 Dothan St., Arlington, MA 02174, (714) 643-4713.

Reader Service ✓ 568

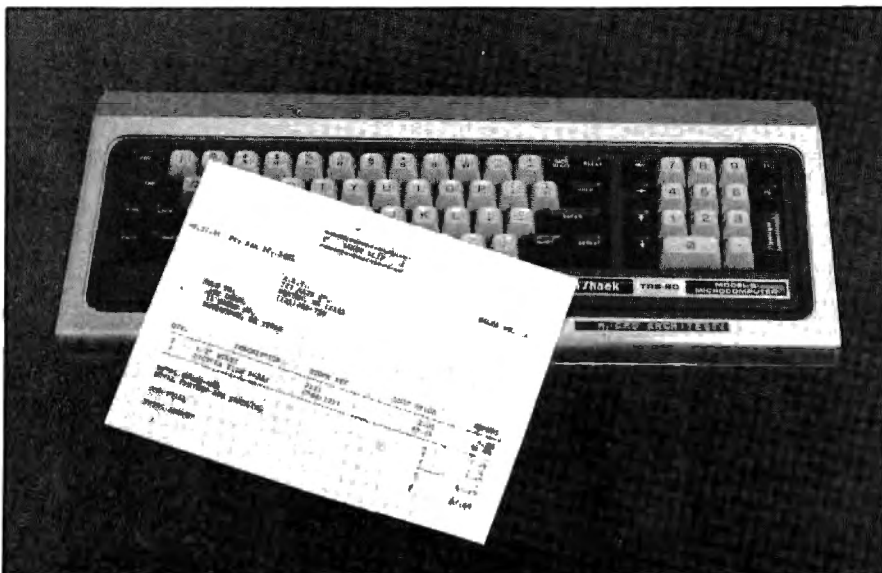

Sample from the INV-X System

CP/M for the Model I

The Mapper/64 converts the Model I into a 64K CP/M machine

The Mapper/64 consists of a printed circuit board that is installed with no additional soldering, cutting and jumpering. This board substitutes 16K of RAM for the ROM Basic when running under CP/M.

FORM LETTER (Use alone or with the mail list system below) \$39.95

Create letters and store on disk with provisions for later retrieval and additions. Then print your letters using your mailing list

- Same select and purge features as mailing list system
- Select either continuous fanfold or "cut sheet" paper
- Selectable tabbing, test printing, and paging
- Allows regular or legal size pages
- Greetings are selectable by codes on mailing list. Options include Mr., Mrs., First/Last Name, global, or user defined

TRY OUR ONE DAY PC BOARD SERVICE

Fast service and high quality at a reasonable price

MAIL LIST SYSTEM (Model I or III) disk only \$89.95

We proudly present here what many consider to be the most versatile and powerful mailing list system on the market today. Note that this newly revised system performs equally well on the very small lists as well as the very large (tens of thousands of entries). To assist you in evaluating our system, we offer our manual alone at essentially our own cost (\$4.95 + \$2.00 P&H). Many of our customers have declared that ours is the most thorough manual they have seen -- yet easily understood.

- Simple to use -- even for the novice.
- Maintain virtually an infinite number of disks all in continuous alph or zip order -- essential for large lists
- Sort **2260** entries (2 full 40 track double density disks) in only 32K or an incredible **4640** entries (2 full 80 track double density disks) in only 48K! Made possible with our unique date compression techniques
- Super fast sort by alph or zip order (8 sec for 1000 entries) -- both orders can exist simultaneously on disk
- High speed recovery of entries from disk -- speed of sort is meaningless if retrieval from disk is slow -- ours pulls in over 11 per sec!
- Transfers old files over to our system **LOOK!**
- Zip order is "sub-alphabetized"
- Less than 5 digit zips have leading 0's appended
- Supports 9 digit zips, **Canadian zips**, and foreign abbrev
- Backup data disks are easily updated as entries are created, edited, or sorted -- extremely useful!
- Optional reversal of name about comma
- Permits telephone, account, and/or serial numbers, etc
- Prints on envelopes or on labels, 1, 2, or 3 across
- Test label envelope printing lets you make horizontal and vertical adjustments with ease
- Master printout of your list in several formats (not just a rehash of the labels) -- extremely useful
- Selective printing by specific zips or by zip range
- Editing is simple and fast -- automatic search. Batch transfer of edited entries to backup disks
- Optionally provides for duplicate labels
- Deleted entries have "holes" on disk filled automatically and alph order is still maintained!
- System adjusts to any DOS.
- Automatic "repeat" feature for ease of entry
- Load and "scroll" through entries on disk
- All labels optionally support an "ATTN" line with provisions for multiple entries
- Plenty of user defined fields with various options for **simultaneously** purging and selecting the printout -- even allows for inequalities -- powerful and easy to use
- All 0's in address labels are replaced by easier to read 0's
- Continuous display of numbers of labels/envelopes printed
- Each disk entry automatically "remembers" how many mailings have been made for that particular entry. Can be tied in with purge select
- Primarily written in BASIC for easy modification -- embedded machine code for those speed sensitive areas
- Extensive use of error traps (both operator and machine induced) -- even recovers from a power failure during a printout! -- recycling on disk errors.
- Hardware requirements: 32K, printer, and 1 or 2 drives

PROVEN QUALITY SOFTWARE FOR YOUR TRS-80*

*Tandy Corp. Trademark

Sign (Supplied on tape only) \$19.95

Produce large (reduced 50% here) attention getting signs with your printer. Supports most keyboard characters. Will print multiple lines -- use alone or interface to your own BASIC program. Requires just over 16K and a printer.

```

      11111111 00000000 -55555555  LL  00000000 00000000  25  AA
      11111111  1  2  3  4  5  6  7  8  9  10 11 12 13 14 15 16 17 18 19 20 21 22 23 24 25 26 27 28 29 30 31 32 33 34 35 36 37 38 39 40 41 42 43 44 45 46 47 48 49 50 51 52 53 54 55 56 57 58 59 60 61 62 63 64 65 66 67 68 69 70 71 72 73 74 75 76 77 78 79 80 81 82 83 84 85 86 87 88 89 90 91 92 93 94 95 96 97 98 99 00 01 02 03 04 05 06 07 08 09 10 11 12 13 14 15 16 17 18 19 20 21 22 23 24 25 26 27 28 29 30 31 32 33 34 35 36 37 38 39 40 41 42 43 44 45 46 47 48 49 50 51 52 53 54 55 56 57 58 59 60 61 62 63 64 65 66 67 68 69 70 71 72 73 74 75 76 77 78 79 80 81 82 83 84 85 86 87 88 89 90 91 92 93 94 95 96 97 98 99 00 01 02 03 04 05 06 07 08 09 10 11 12 13 14 15 16 17 18 19 20 21 22 23 24 25 26 27 28 29 30 31 32 33 34 35 36 37 38 39 40 41 42 43 44 45 46 47 48 49 50 51 52 53 54 55 56 57 58 59 60 61 62 63 64 65 66 67 68 69 70 71 72 73 74 75 76 77 78 79 80 81 82 83 84 85 86 87 88 89 90 91 92 93 94 95 96 97 98 99 00 01 02 03 04 05 06 07 08 09 10 11 12 13 14 15 16 17 18 19 20 21 22 23 24 25 26 27 28 29 30 31 32 33 34 35 36 37 38 39 40 41 42 43 44 45 46 47 48 49 50 51 52 53 54 55 56 57 58 59 60 61 62 63 64 65 66 67 68 69 70 71 72 73 74 75 76 77 78 79 80 81 82 83 84 85 86 87 88 89 90 91 92 93 94 95 96 97 98 99 00 01 02 03 04 05 06 07 08 09 10 11 12 13 14 15 16 17 18 19 20 21 22 23 24 25 26 27 28 29 30 31 32 33 34 35 36 37 38 39 40 41 42 43 44 45 46 47 48 49 50 51 52 53 54 55 56 57 58 59 60 61 62 63 64 65 66 67 68 69 70 71 72 73 74 75 76 77 78 79 80 81 82 83 84 85 86 87 88 89 90 91 92 93 94 95 96 97 98 99 00 01 02 03 04 05 06 07 08 09 10 11 12 13 14 15 16 17 18 19 20 21 22 23 24 25 26 27 28 29 30 31 32 33 34 35 36 37 38 39 40 41 42 43 44 45 46 47 48 49 50 51 52 53 54 55 56 57 58 59 60 61 62 63 64 65 66 67 68 69 70 71 72 73 74 75 76 77 78 79 80 81 82 83 84 85 86 87 88 89 90 91 92 93 94 95 96 97 98 99 00 01 02 03 04 05 06 07 08 09 10 11 12 13 14 15 16 17 18 19 20 21 22 23 24 25 26 27 28 29 30 31 32 33 34 35 36 37 38 39 40 41 42 43 44 45 46 47 48 49 50 51 52 53 54 55 56 57 58 59 60 61 62 63 64 65 66 67 68 69 70 71 72 73 74 75 76 77 78 79 80 81 82 83 84 85 86 87 88 89 90 91 92 93 94 95 96 97 98 99 00 01 02 03 04 05 06 07 08 09 10 11 12 13 14 15 16 17 18 19 20 21 22 23 24 25 26 27 28 29 30 31 32 33 34 35 36 37 38 39 40 41 42 43 44 45 46 47 48 49 50 51 52 53 54 55 56 57 58 59 60 61 62 63 64 65 66 67 68 69 70 71 72 73 74 75 76 77 78 79 80 81 82 83 84 85 86 87 88 89 90 91 92 93 94 95 96 97 98 99 00 01 02 03 04 05 06 07 08 09 10 11 12 13 14 15 16 17 18 19 20 21 22 23 24 25 26 27 28 29 30 31 32 33 34 35 36 37 38 39 40 41 42 43 44 45 46 47 48 49 50 51 52 53 54 55 56 57 58 59 60 61 62 63 64 65 66 67 68 69 70 71 72 73 74 75 76 77 78 79 80 81 82 83 84 85 86 87 88 89 90 91 92 93 94 95 96 97 98 99 00 01 02 03 04 05 06 07 08 09 10 11 12 13 14 15 16 17 18 19 20 21 22 23 24 25 26 27 28 29 30 31 32 33 34 35 36 37 38 39 40 41 42 43 44 45 46 47 48 49 50 51 52 53 54 55 56 57 58 59 60 61 62 63 64 65 66 67 68 69 70 71 72 73 74 75 76 77 78 79 80 81 82 83 84 85 86 87 88 89 90 91 92 93 94 95 96 97 98 99 00 01 02 03 04 05 06 07 08 09 10 11 12 13 14 15 16 17 18 19 20 21 22 23 24 25 26 27 28 29 30 31 32 33 34 35 36 37 38 39 40 41 42 43 44 45 46 47 48 49 50 51 52 53 54 55 56 57 58 59 60 61 62 63 64 65 66 67 68 69 70 71 72 73 74 75 76 77 78 79 80 81 82 83 84 85 86 87 88 89 90 91 92 93 94 95 96 97 98 99 00 01 02 03 04 05 06 07 08 09 10 11 12 13 14 15 16 17 18 19 20 21 22 23 24 25 26 27 28 29 30 31 32 33 34 35 36 37 38 39 40 41 42 43 44 45 46 47 48 49 50 51 52 53 54 55 56 57 58 59 60 61 62 63 64 65 66 67 68 69 70 71 72 73 74 75 76 77 78 79 80 81 82 83 84 85 86 87 88 89 90 91 92 93 94 95 96 97 98 99 00 01 02 03 04 05 06 07 08 09 10 11 12 13 14 15 16 17 18 19 20 21 22 23 24 25 26 27 28 29 30 31 32 33 34 35 36 37 38 39 40 41 42 43 44 45 46 47 48 49 50 51 52 53 54 55 56 57 58 59 60 61 62 63 64 65 66 67 68 69 70 71 72 73 74 75 76 77 78 79 80 81 82 83 84 85 86 87 88 89 90 91 92 93 94 95 96 97 98 99 00 01 02 03 04 05 06 07 08 09 10 11 12 13 14 15 16 17 18 19 20 21 22 23 24 25 26 27 28 29 30 31 32 33 34 35 36 37 38 39 40 41 42 43 44 45 46 47 48 49 50 51 52 53 54 55 56 57 58 59 60 61 62 63 64 65 66 67 68 69 70 71 72 73 74 75 76 77 78 79 80 81 82 83 84 85 86 87 88 89 90 91 92 93 94 95 96 97 98 99 00 01 02 03 04 05 06 07 08 09 10 11 12 13 14 15 16 17 18 19 20 21 22 23 24 25 26 27 28 29 30 31 32 33 34 35 36 37 38 39 40 41 42 43 44 45 46 47 48 49 50 51 52 53 54 55 56 57 58 59 60 61 62 63 64 65 66 67 68 69 70 71 72 73 74 75 76 77 78 79 80 81 82 83 84 85 86 87 88 89 90 91 92 93 94 95 96 97 98 99 00 01 02 03 04 05 06 07 08 09 10 11 12 13 14 15 16 17 18 19 20 21 22 23 24 25 26 27 28 29 30 31 32 33 34 35 36 37 38 39 40 41 42 43 44 45 46 47 48 49 50 51 52 53 54 55 56 57 58 59 60 61 62 63 64 65 66 67 68 69 70 71 72 73 74 75 76 77 78 79 80 81 82 83 84 85 86 87 88 89 90 91 92 93 94 95 96 97 98 99 00 01 02 03 04 05 06 07 08 09 10 11 12 13 14 15 16 17 18 19 20 21 22 23 24 25 26 27 28 29 30 31 32 33 34 35 36 37 38 39 40 41 42 43 44 45 46 47 48 49 50 51 52 53 54 55 56 57 58 59 60 61 62 63 64 65 66 67 68 69 70 71 72 73 74 75 76 77 78 79 80 81 82 83 84 85 86 87 88 89 90 91 92 93 94 95 96 97 98 99 00 01 02 03 04 05 06 07 08 09 10 11 12 13 14 15 16 17 18 19 20 21 22 23 24 25 26 27 28 29 30 31 32 33 34 35 36 37 38 39 40 41 42 43 44 45 46 47 48 49 50 51 52 53 54 55 56 57 58 59 60 61 62 63 64 65 66 67 68 69 70 71 72 73 74 75 76 77 78 79 80 81 82 83 84 85 86 87 88 89 90 91 92 93 94 95 96 97 98 99 00 01 02 03 04 05 06 07 08 09 10 11 12 13 14 15 16 17 18 19 20 21 22 23 24 25 26 27 28 29 30 31 32 33 34 35 36 37 38 39 40 41 42 43 44 45 46 47 48 49 50 51 52 53 54 55 56 57 58 59 60 61 62 63 64 65 66 67 68 69 70 71 72 73 74 75 76 77 78 79 80 81 82 83 84 85 86 87 88 89 90 91 92 93 94 95 96 97 98 99 00 01 02 03 04 05 06 07 08 09 10 11 12 13 14 15 16 17 18 19 20 21 22 23 24 25 26 27 28 29 30 31 32 33 34 35 36 37 38 39 40 41 42 43 44 45 46 47 48 49 50 51 52 53 54 55 56 57 58 59 60 61 62 63 64 65 66 67 68 69 70 71 72 73 74 75 76 77 78 79 80 81 82 83 84 85 86 87 88 89 90 91 92 93 94 95 96 97 98 99 00 01 02 03 04 05 06 07 08 09 10 11 12 13 14 15 16 17 18 19 20 21 22 23 24 25 26 27 28 29 30 31 32 33 34 35 36 37 38 39 40 41 42 43 44 45 46 47 48 49 50 51 52 53 54 55 56 57 58 59 60 61 62 63 64 65 66 67 68 69 70 71 72 73 74 75 76 77 78 79 80 81 82 83 84 85 86 87 88 89 90 91 92 93 94 95 96 97 98 99 00 01 02 03 04 05 06 07 08 09 10 11 12 13 14 15 16 17 18 19 20 21 22 23 24 25 26 27 28 29 30 31 32 33 34 35 36 37 38 39 40 41 42 43 44 45 46 47 48 49 50 51 52 53 54 55 56 57 58 59 60 61 62 63 64 65 66 67 68 69 70 71 72 73 74 75 76 77 78 79 80 81 82 83 84 85 86 87 88 89 90 91 92 93 94 95 96 97 98 99 00 01 02 03 04 05 06 07 08 09 10 11 12 13 14 15 16 17 18 19 20 21 22 23 24 25 26 27 28 29 30 31 32 33 34 35 36 37 38 39 40 41 42 43 44 45 46 47 48 49 50 51 52 53 54 55 56 57 58 59 60 61 62 63 64 65 66 67 68 69 70 71 72 73 74 75 76 77 78 79 80 81 82 83 84 85 86 87 88 89 90 91 92 93 94 95 96 97 98 99 00 01 02 03 04 05 06 07 08 09 10 11 12 13 14 15 16 17 18 19 20 21 22 23 24 25 26 27 28 29 30 31 32 33 34 35 36 37 38 39 40 41 42 43 44 45 46 47 48 49 50 51 52 53 54 55 56 57 58 59 60 61 62 63 64 65 66 67 68 69 70 71 72 73 74 75 76 77 78 79 80 81 82 83 84 85 86 87 88 89 90 91 92 93 94 95 96 97 98 99 00 01 02 03 04 05 06 07 08 09 10 11 12 13 14 15 16 17 18 19 20 21 22 23 24 25 26 27 28 29 30 31 32 33 34 35 36 37 38 39 40 41 42 43 44 45 46 47 48 49 50 51 52 53 54 55 56 57 58 59 60 61 62 63 64 65 66 67 68 69 70 71 72 73 74 75 76 77 78 79 80 81 82 83 84 85 86 87 88 89 90 91 92 93 94 95 96 97 98 99 00 01 02 03 04 05 06 07 08 09 10 11 12 13 14 15 16 17 18 19 20 21 22 23 24 25 26 27 28 29 30 31 32 33 34 35 36 37 38 39 40 41 42 43 44 45 46 47 48 49 50 51 52 53 54 55 56 57 58 59 60 61 62 63 64 65 66 67 68 69 70 71 72 73 74 75 76 77 78 79 80 81 82 83 84 85 86 87 88 89 90 91 92 93 94 95 96 97 98 99 00 01 02 03 04 05 06 07 08 09 10 11 12 13 14 15 16 17 18 19 20 21 22 23 24 25 26 27 28 29 30 31 32 33 34 35 36 37 38 39 40 41 42 43 44 45 46 47 48 49 50 51 52 53 54 55 56 57 58 59 60 61 62 63 64 65 66 67 68 69 70 71 72 73 74 75 76 77 78 79 80 81 82 83 84 85 86 87 88 89 90 91 92 93 94 95 96 97 98 99 00 01 02 03 04 05 06 07 08 09 10 11 12 13 14 15 16 17 18 19 20 21 22 23 24 25 26 27 28 29 30 31 32 33 34 35 36 37 38 39 40 41 42 43 44 45 46 47 48 49 50 51 52 53 54 55 56 57 58 59 60 61 62 63 64 65 66 67 68 69 70 71 72 73 74 75 76 77 78 79 80 81 82 83 84 85 86 87 88 89 90 91 92 93 94 95 96 97 98 99 00 01 02 03 04 05 06 07 08 09 10 11 12 13 14 15 16 17 18 19 20 21 22 23 24 25 26 27 28 29 30 31 32 33 34 35 36 37 38 39 40 41 42 43 44 45 46 47 48 49 50 51 52 53 54 55 56 57 58 59 60 61 62 63 64 65 66 67 68 69 70 71 72 73 74 75 76 77 78 79 80 81 82 83 84 85 86 87 88 89 90 91 92 93 94 95 96 97 98 99 00 01 02 03 04 05 06 07 08 09 10 11 12 13 14 15 16 17 18 19 20 21 22 23 24 25 26 27 28 29 30 31 32 33 34 35 36 37 38 39 40 41 42 43 44 45 46 47 48 49 50 51 52 53 54 55 56 57 58 59 60 61 62 63 64 65 66 67 68 69 70 71 72 73 74 75 76 77 78 79 80 81 82 83 84 85 86 87 88 89 90 91 92 93 94 95 96 97 98 99 00 01 02 03 04 05 06 07 08 09 10 11 12 13 14 15 16 17 18 19 20 21 22 23 24 25 26 27 28 29 30 31 32 33 34 35 36 37 38 39 40 41 42 43 44 45 46 47 48 49 50 51 52 53 54 55 56 57 58 59 60 61 62 63 64 65 66 67 68 69 70 71 72 73 74 75 76 77 78 79 80 81 82 83 84 85 86 87 88 89 90 91 92 93 94 95 96 97 98 99 00 01 02 03 04 05 06 07 08 09 10 11 12 13 14 15 16 17 18 19 20 21 22 23 24 25 26 27 28 29 30 31 32 33 34 35 36 37 38 39 40 41 42 43 44 45 46 47 48 49 50 51 52 53 54 55 56 57 58 59 60 61 62 63 64 65 66 67 68 69 70 71 72 73 74 75 76 77 78 79 80 81 82 83 84 85 86 87 88 89 90 91 92 93 94 95 96 97 98 99 00 01 02 03 04 05 06 07 08 09 10 11 12 13 14 15 16 17 18 19 20 21 22 23 24 25 26 27 28 29 30 31 32 33 34 35 36 37 38 39 40 41 42 43 44 45 46 47 48 49 50 51 52 53 54 55 56 57 58 59 60 61 62 63 64 65 66 67 68 69 70 71 72 73 74 75 76 77 78 79 80 81 82 83 84 85 86 87 88 89 90 91 92 93 94 95 96 97 98 99 00 01 02 03 04 05 06 07 08 09 10 11 12 13 14 15 16 17 18 19 20 21 22 23 24 25 26 27 28 29 30 31 32 33 34 35 36 37 38 39 40 41 42 43 44 45 46 47 48 49 50 51 52 53 54 55 56 57 58 59 60 61 62 63 64 65 66 67 68 69 70 71 72 73 74 75 76 77 78 79 80 81 82 83 84 85 86 87 88 89 90 91 92 93 94 95 96 97 98 99 00 01 02 03 04 05 06 07 08 09 10 11 12 13 14 15 16 17 18 19 20 21 22 23 24 25 26 27 28 29 30 31 32 33 34 35 36 37 38 39 40 41 42 43 44 45 46 47 48 49 50 51 52 53 54 55 56 57 58 59 60 61 62 63 64 65 66 67 68 69 70 71 72 73 74 75 76 77 78 79 80 81 82 83 84 85 86 87 88 89 90 91 92 93 94 95 96 97 98 99 00 01 02 03 04 05 06 07 08 09 10 11 12 13 14 15 16 17 18 19 20 21 22 23 24 25 26 27 28 29 30 31 32 33 34 35 36 37 38 39 40 41 42 43 44 45 46 47 48 49 50 51 52 53 54 55 56 57 58 59 60 61 62 63 64 65 66 67 68 69 70 71 72 73 74 75 76 7
```

NEW PRODUCTS

This product enables your Model I to run most of the CP/M software on the market and languages including Pascal, Fortran and Cobol.

Complete with documentation and CP/M 2.2, the Mapper costs \$439 and is available from Omikron, 1127 Hearst Ave., Berkeley, CA 94702, (415) 845-8013.

Reader Service ✓ 583

Problem Solving On the TRS-80 Pocket Computer

Problem Solving on the TRS-80 Pocket Computer by Don Inman and Jim Conlan, begins with a nuts and bolts approach to the machine's own form of Basic, its keyboard and special features.

Further instruction describes a range of practical and educational applications and exposes the multiple problem-solving capabilities of the Pocket Computer. Ready-to-run programs are included for common data processing functions.

The book, priced at \$8.95, is available from John Wiley and Sons, 605 3rd Ave., New York, NY 10158, (212) 850-6497.

Reader Service ✓ 581

For Personal Finances

Perfin is a customized program enabling you to make periodic audits of your personal finance status.

It allows foolproof and bombproof entries of your bank accounts, real estate holdings, stock and bond investments and more. Each category is automatically totalled and compared with previous audits to show your current financial status. Your entries are recorded on disk and listed on screen with optional printout.

Perfin is supplied on cassette for transfer to your disk for the Models I and III. It is priced at \$11.95 and is available from Shirley Software, Box 417, Old Greenwich, CT 06870.

Reader Service ✓ 569

One Key Loading

ONEKEYII loads any of the 96 possible runnable programs listed in a TRSDOS directory with a single keystroke. Arrows are used to roll files up or down as if they were on a continuous loop. Hitting Enter selects the program and one key can be

used to load, run, kill or return to System.

The screen format is exactly like the TRSDOS directory. The top lines of column headings and bottom line of granule and extent information remains stationary while files scroll up or down in between. ONEKEYII updates itself automatically, no filespec typing is required, and it operates in machine language.

Available for the Model II on disk for \$40 from Hugh Roberts, Box 158, Linn Grove, IA, 51033.

Reader Service ✓ 560

Drive Control Unit

Optronics Technology has introduced a product for eight-inch floppy-disk users which provides automatic on/off control for the drive motor. This eliminates noise from the drive unit as well as significantly reducing media wear.

The Drive Control Unit (D.C.U.) is designed for easy installation and has connectors which allow it to fit within the drive assembly in series with the drive motor. During drive access, the motor is energized at zero-crossing for low noise and turns itself off after eight seconds (adjustable) of idle time.

The unit is available in kit form for \$18.95 or assembled for \$29.95 from Optronics Technology, Box 81, Pittsford, NY 14534.

Reader Service ✓ 599

The Simple Switch

The Disk-Tape Exchanger utility package allows transferring machine-language programs from disk to tape or from tape to disk.

Two programs are included in the package. TMDisk allows placing machine-language tapes on disk without conflicting with DOS or Disk Basic. SYSDump allows placing "ICMD" disk files on tape.

The Disk-Tape Exchanger is available from Instant Software Inc., Peterborough, NH 03458, (603) 924-9471. It retails for \$24.95.

Reader Service ✓ 591

Computer Software

The Giant Book of Computer Software begins with the fundamentals of computer languages assuming the reader has no

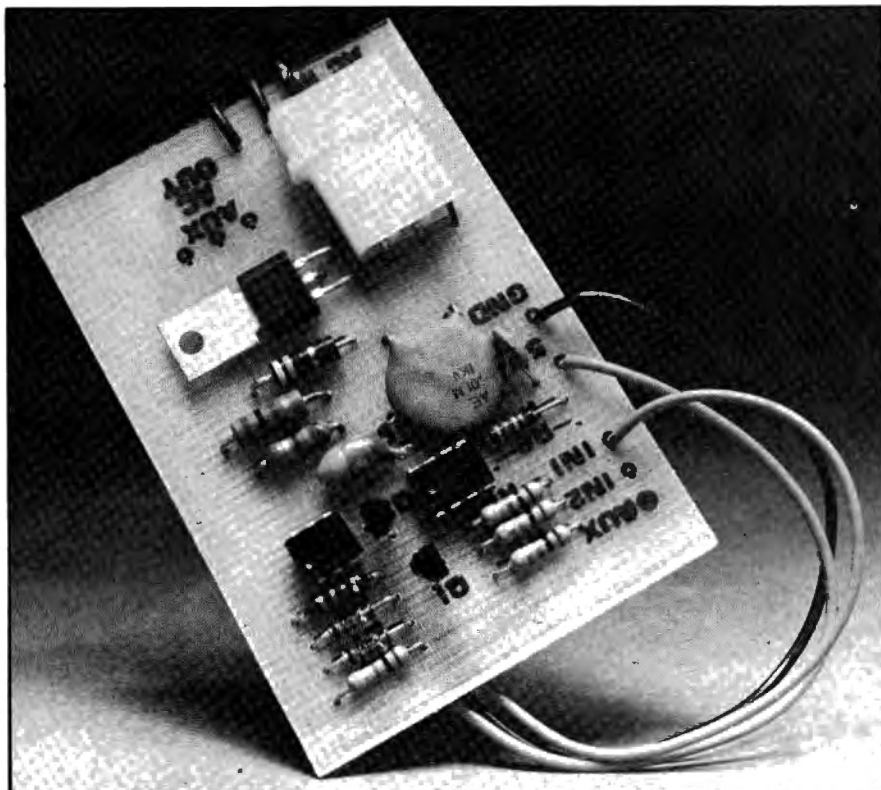

The Optronics Drive Control Unit

We're not soft on software

Data resources continues its commitment to professional quality TRS-80® software with the Silver Edition Software Series...selected programs from talented and popular authors.

Data Resources

New subsystems for Aids III AIDS FILE EDITOR

Allows you to update and edit records in AIDS data files without loading the file into memory. Now you can change a single record in a mailing list quickly and easily with random access selection.

MODEL I \$24.95

AIDS DATA ENTRY MODULE

Designed for inputting data directly into AIDS Disk files. Fields may be fixed to repeat the same data. The key-in routines are improved in speed. Data can be added to the end of an existing file or a new file can be created, no more than 255 key-strokes can be lost.

MODEL I \$24.95

AIDS DISK SORT

Designed for files that are too large to sort "in memory" with AIDS or for when you don't want to wait while AIDS loads the records. Records are physically rearranging on disk.

MODEL I \$24.92

AIDS SYSTEMS BY META TECHNOLOGIES MTC AIDS III

This easy to use system allows even a novice TRS-80 user to create data files custom configured for many applications from cash flow analysis and financial journals to price lists and record keeping. It requires NO PROGRAMMING and is complete with features for adding, deleting, sorting, updating and printing.

MODEL I or III \$69.95

MTC CALCS III

Performs numeric calculations of data contained in AIDS files. Ideal for financial applications.

MODEL I or III \$24.95

MTC CALCS IV

The same features as CALCS III with more powerful formulas and the ability to store report formats.

MODEL I or III \$39.95

MTC MERGE III

Combines up to 14 AIDS data files into a single file. Duplicates may optionally be purged, and sorted order of records is maintained.

MODEL I or III \$19.95

INTERACTIVE BUSINESS SYSTEM INVENTORY CONTROL

By Tom Williams

The interactive system for inventory control offers the small manufacturing business savings in the thousands of dollars in reduced staff and accounting costs. Here's how it works...

When an invoice is typed:

- the customer's name and both addresses are obtained from the CUSTOMER LIST file.
- the company data is obtained from the COMPANY DATA file.
- the product data is retrieved from the INVENTORY CONTROL file.
- the INVENTORY CONTROL DATA file is updated by the invoice.
- the SALES DATA file is updated by the invoice.
- the invoice is automatically entered in the ACCOUNTS RECEIVABLE file.

The results are: the invoice is typed, customer data is gathered, items purchased are listed, multiples extended, invoice totalled, discounts computed, shipping costs added, interest added for late payers and data is entered in inventory control, sales data file and in accounts receivable...in about 50 seconds without mathematical or posting error.

For Model I or III \$500.00

B.T. ENTERPRISES UNITERM/80

By Pete Roberts

This is the state-of-the-art in communications software. It configures itself for either Model I or Model III and can be used with any standard modem, both RS-232 and Bus-Decoding. Especially designed to use the extended commands in NEWDOS/80, but fully compatible with all major DOS systems.

For Model I and III \$89.00

THE FLOPPY DOCTOR

By Dave Stambaugh

FLOPPY DISK/MEMORY DIAGNOSTIC programs are designed to thoroughly check out the two most trouble prone sections of the TRS-80, the disk system (controller and drives) and the memory arrays.

MODEL I \$24.95

MODEL III \$29.95

NEWDOS/80 Version 2.0 for MODEL I and III

The hottest Disk Operating System is now available in its latest version. This is the ONE from Apparat, Inc., the people whose systems have made the TRS-80 the reliable computer.

..... \$149.00

SPECIAL

AIDS III Super systems

AIDS III & CALCS III & MERGE III

MODEL I or III \$99.95

AIDS III & CALCS IV & MERGE III

MODEL I or III \$109.95

**1984 DATA RESOURCES CORP.
TRS-80® IS A TRADEMARK OF TANDY
CORP.**

Prices in effect April 1, 1982 to May 1, 1982 and subject to changes

ANSWER \$249.00 By NABS

Answer...a new type of information organizer. Utilizing the directory principle, Answer solves information problems by creating simple forms enabling you to put information where it should be or in many different places at the same time.

Answer...lets you organize almost any type of information in many different sequences and lets each information group grow to almost any size. It is able to connect the information on hundreds of diskettes. You can solve many problems yourself...without programming skills.

- Split screen design
- Multiple records on screen
- On-screen form creation
- Multi-level menu driven
- Compound data base
- Variable length random access
- 25 Key fields plus...
- Supports 1-4 diskette drives
- Interactive editing
- Record lock-out
- All keys equal.

MODEL I DOUBLE DENSITY PACKAGES

NEWDOS/80 Version 2.0

and the LNDOUBLER \$219.95

DOSPLUS and the LNDOUBLER ... \$169.95

Everything you need to convert your TRS-80 Model I, to run double density. Complete with software, hardware, and instructions, installs in minutes with no soldering, wiring or cutting.

LNDOUBLER Alone \$139.95

DOSPLUS

for MODEL I and III \$99.95

DOSPLUS gives you more of what you buy an operating system for. Speed and reliability without sacrificing simplicity and power. If you need extra power without extra wait, then you need DOSPLUS!



**Data
Resources**

**304 Elati
Denver, CO 80223
(303) 698-1263**

To order call toll free.

(800) 525-8394 ✓15

**Mastercard and Visa welcome
Checks - COD - Money Orders also
accepted**

Orders shipped UPS free.

**Colorado residents add 6½ per
cent sales tax**

Attractive discounts to dealers

**AIDS III®, CALCS III®, MERGE III®, ARE
TRADEMARKS OF
METATECHNOLOGIES**

“You Don't Have to be to Give Your TRS-80 Just Pick Up

WINCHESTER TRS

ADD 6.3 MEG TO 38

VR Data has grown with the microcomputer industry for over ten years.

We've based our success on producing quality products, always on the leading edge of the technological revolution.

Our designs are tested, re-tested, and “burned in.” We are so sure of our quality control, we offer you a 120 day warranty including full coverage of parts and labor.

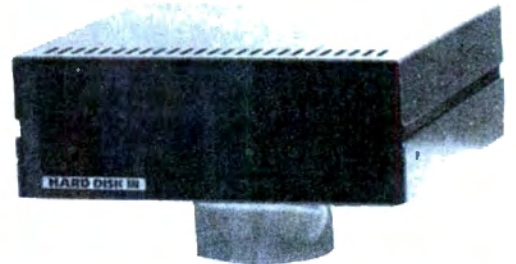

Warren G. Rosenkranz
President VR Data Corporation
since 1972

VISA

VRdata

777 Henderson Boulevard N-6
Folcroft, PA 19032 (215) 461-5300

Call Toll-Free
800-345-8102
in PA **215-461-5300**



ALL VR DATA PRODUCTS CARRY A 120-DAY WARRANTY INCLUDING PARTS & LABOR

Published prices reflect cash discount. All prices are subject to change without notice. TRS-80 and TRSDOS are trademarks of Tandy Corp. DISK III is a trademark of VR Data Corp.

8:30AM-7PM E.S.T. Mon.-Fri., Sat. 10AM-3PM
CABLE “VRDATA” TELEX 845-124

Phone or write to order direct, or for name of your nearest dealer.

If you don't see it advertised call us and ask for it.

a Genius, or Croesus, Additional Capabilities, the Phone.”

WARREN ROSENKRANZ,
PRESIDENT OF VR DATA

HARD DISK FOR -80™

MEG TO YOUR TRS-80

VR DATA WINCHESTER HD SUBSYSTEM FEATURES:

- TRSDOS Compatible Operating System
- State-of-the-Art Circuitry
- Full Calibration, Test and Burn-in
- Up to 4 drive configuration
- Heavy duty Power supplies
- Warranty—120 days—parts & labor
- 115/230 VAC, 50/60 Hz.

6.3 MEGABYTE WINCHESTER
(external) HARD DISK SUBSYSTEM
With Chassis,
PS, DOSPLUS **\$3195**

Optional Winchester Subsystem Configurations:

9.5 MEGABYTE	\$3695
19.0 MEGABYTE	\$4295
2 x 6.3 meg drives	\$4695
2 x 9.5 meg drives	\$5395
2 x 19.0 meg drives	\$6795

MODEL III COMMUNICATIONS

HERE NOW:

VR-RS232C **\$90.00**
Direct Replacement For
R.S. RS232, Fully Tested
& Burned-In, Easy
Installation, 120 Day
Warranty, Programmable
Pinout, Prototype Area

COMING SOON:

D-CON **\$299**
Integral Modem,
NEEDS NO RS232—Direct
Connect, Programmable
Dialing, AUTO
ANSWER/ORIGINATE,
Easy Installation

DISK III 100% Compatible

COMPARE AND SAVE
Model III Disks

Complete Business System includes:
48K TRS-80™ Model III, Disk III™-2
Drive System, TRSDOS
and Manual **\$1882**

DISK III Single drive assy. ¹	\$599
DISK III Two drive assy.	\$864.00
DISK III Assy. w/out drives	\$435.00
TRSDOS™ & Manual	\$21.90
DOSPLUS	\$149.00
LDOS	\$129.00
External drives (3&4)	\$275.00 ea.
40tk 2 sided floppy (optional)	add \$120.00
80tk 1 sided floppy (optional)	add \$120.00
80tk 2 sided floppy (optional)	add \$240.00

¹DISK III single drive assembly includes: one 40 track 5¼" double density drive, power supply, controller, mounting hardware, applicable cables, and manual.

VR Data's DISK III features:

- Completely compatible with TRSDOS
- State-of-the-art circuitry
- Fully tested, calibrated & burned-in
- Up to 4 drive configuration
- Warranty 120 days—100% parts and labor
- Installation with simple hand tools
- Optional 80 tk and 2 sided drives
- READ 40—Pgm. to read 40 tk. Diskettes on 80 tk. Drives \$25.00

MODEL I/III External Drive w/PS & ENC **\$275**

Fully Compatible, 120 day warranty,
Easy installation
80 tk or 2 sided **\$419.00**
80 tk & 2 sided **\$549.00**

Other Products

DISK & MYSTERIES BOOK	\$22.50
BASIC & MYSTERIES BOOK	29.95
NEC Ribbons (min. 6)	5.95
C Itoh Ribbons	5.95
Epson Ribbons—MX-80	12.50
LDOS Operating System	129.00
DOSPLUS Operating System	149.00

Peripherals

Epson MX-80 w/GRAPHTRAX	\$595.00
Epson MX-80FT	615.00
Epson MX-100	800.00
Centronics 739	700.00
CENTRONICS 704	1749.00
C ITOH F-10 40 cps	1695.00
Tractor	200.00
Printer cables	25.00
LEXICON MODEM	125.00

NEW PRODUCTS

knowledge of programming whatsoever.

The contents include: an introduction to computer languages, beginning through advanced programming techniques, electronics and antenna programming, ham radio operating programs, RTTY and SSTV programs, games, and more.

The book is available from Tab Books Inc., Blue Ridge Summit, PA 17214, (717) 794-2191. It costs \$21.95 hardbound, \$13.95 paperback.

Reader Service ✓ 593

Copy-Tape

Copy-Tape is a utility program used to duplicate Basic or System tapes on the Model I and III.

On the Model III, Copy-Tape also converts 500 baud to 1500 baud and vice versa. This utility program has menu-driven options including one which advances the tape for your convenience. Copy-Tape allows scanning through memory and viewing the ASCII code of the program you duplicate and a verify command makes it possible to check tapes for validity.

Available for the Model I, Level II and Model III with 16K. The guaranteed cassette tape sells for \$9.95 and is available from David Modney, 4144 N. Via Villas, Tucson, AZ 85719, (602) 293-5186.

Reader Service ✓ 584

Educational Software

Testrite stores test items and generates customized tests suitable for all grade levels from the middle elementary through college and technical schools. Testrite allows teachers to efficiently maintain curricula referenced test item files.

Test items from any discipline may be entered, edited, selected and printed as classroom ready tests and study guides. Whole files, portions of files or selected questions may be used to print a single test. Large exams may be created from multiple files. Questions may be printed in either multiple choice, true/false, matching and completion. Numbering options, customized titles and user edited test taking instructions give the program flexibility.

Versions are available for the Model I, III and for the Model II with CP/M for \$139 from Class 1 Systems, 17909 Maple St., Lansing, IL 60438, (312) 474-4664.

Reader Service ✓ 570

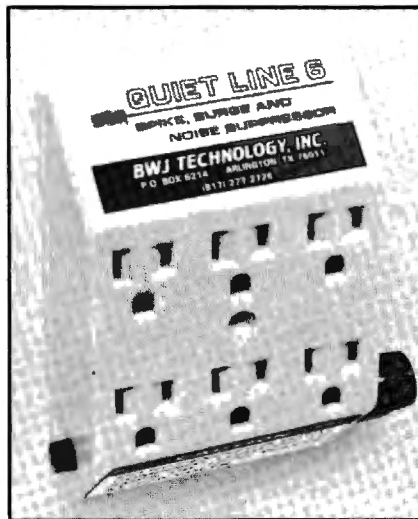

The Quietline 6

Quietline 6

Quietline 6 is a power-line conditioner for electronic applications which continuously monitors your ac power source, protecting sensitive equipment from power-line interference and surges.

This product plugs directly into a standard wall socket, converting it to six fully protected outlets. When detected, surges and interference are purged from the power line by the activation of protective circuitry. Interference is also prevented from contaminating the ac power line when noisy electrical equipment is plugged into the unit.

The conditioner is available for \$39.95 from BWJ Technology Inc., Box 6214, Arlington, TX 76011.

Reader Service ✓ 552

Data Ace

Data Ace is now available for Models I, II, and III.

This product combines a Data Base Management and Operating System, a conversational Data Definition Language (DDL), an interactive Query Language (DIL), a Block Structured programming language for easy development and a full screen text editor to create and maintain programs and procedures. The combination of these features enable the user to automate a business rapidly to the exact requirements needed. The Model I and III version include MMSFORTH. The Model II offering is supported with a General Accounting Package.

Data Ace runs on Models I and III with 48K. This version costs \$375. It also runs

on the Model II with 64K, an expansion box, at least one drive and a printer. The price of this system is \$1350. The package includes a utilities disk, a demonstration disk, two systems disks, and both volumes of the Users Guide.

For additional information, contact Computer Software Design, Inc., 1911 Wright Circle, Anaheim, CA 92806, (714) 634-9012.

Reader Service ✓ 568

Speaking Pascal

Speaking Pascal: A Computer Language Primer is written in concise mathematical language. The text requires no technical background or previous programming experience on the part of the reader.

The author employs top-down structured analysis and key examples to illustrate new ideas. Readers are encouraged to construct programs in an organized manner for complete understanding. Elementary and complex data types are covered, as well as the use of control structures, procedures and functions. Extensive artwork, illustrations, and exercises at the end of each chapter are included.

For more detailed information contact Hayden Book Co., 50 Essex St., Rochelle Park, NJ 07662, (800) 631-0856.

Reader Service ✓ 572

Epsset

Epsset is a set of files that enable users of the Epson MX-80 printers to set CPI, column width, line spacing, and do printer test runs under direct control from the keyboard of their terminals without having to write software programs.

The disk includes a series of nine files, eight of which are for testing the printer's accuracy in printing its entire set of ASCII characters including numbers, upper and lowercase alphabets, punctuation, and graphic blocks in column widths of 10 to 80. The eighth file provides a menu for instantaneous selection and configuration of the MX-80 for combinations of CPI; single, double, and emphasized strike; and line spacing.

Written in PL/I 80, Epsset is available for systems running CP/M with 32K from Success Analysis Corp., 743 Holly Oak Dr., Palo Alto, CA 94303, (415) 494-2613.

Reader Service ✓ 573

GIVE YOUR COMPUTER SOME CLOUT WITH SASI-NET BY MICRO MAINFRAME

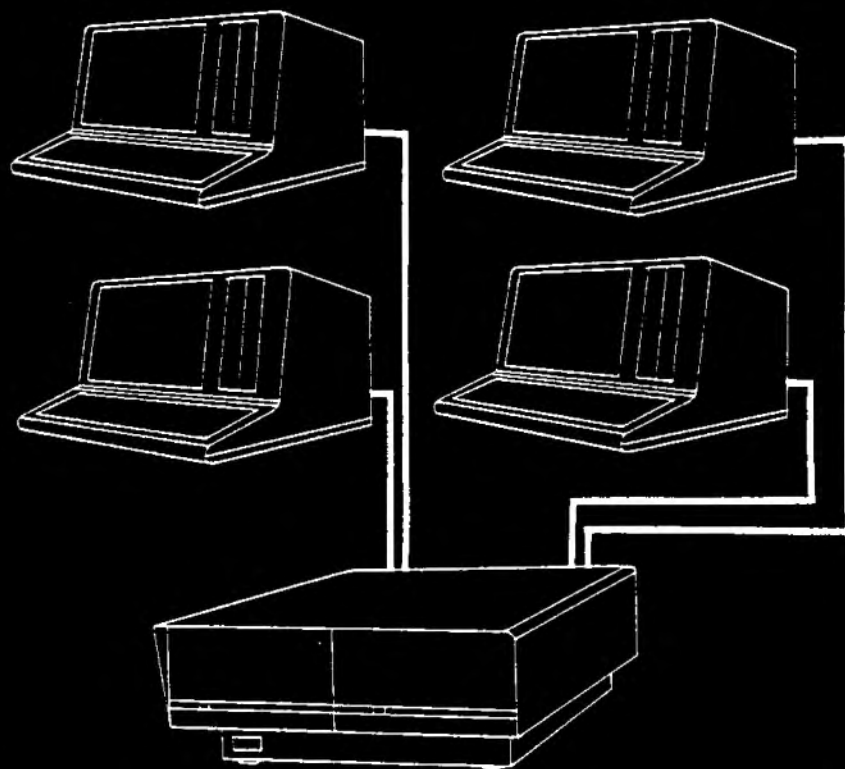

THE SASI-NET MULTIPLEXER

- Maximizes computing power
- Virtually infinite expansion
- Low initial cost
- Graceful growth
- Reasonable expansion costs
- Integrated system design for maximum throughput
- Expand your system to one of the largest possible systems with additional multiplexers, CPU's, hard disks and host adapters.

For a limited time only, we are offering 5 and 10 Megabyte disk drive systems with our DMX 1 SASI-NET multiplexer built in. Additional multiplexers may be purchased for \$795.00 each. Compare our price and performance.

SYSTEM PRICING

Price includes disk subsystem, host adapter, SASI-NET, and DosPlus 4.0D*. Mod-II* operating system available at additional cost.

SASI-NET Multiplexer	\$ 795.00 ea.
M-50FM (5.2 Megabytes formatted)	\$3195.00 ea.
M-100FM (11.1 Megabytes formatted)	\$3995.00 ea.
Additional Host Adapters available for	\$ 325.00 ea.
FDC-3B Floppy Disk Controller Board	\$ 139.95 ea.
FDC-3C Floppy Disk Controller (runs 5" and 8" floppy disks)	\$ 199.95 ea.

Call for the location of your nearest Micro Mainframe Dealer
Dealers please inquire on your letterhead

MICRO MAINFRAME

2227 McGregor Ave. • Rancho Cordova, CA 95670
(916) 635-3997

MICRO MAINFRAMES

NEW PRODUCTS

Reference Sheet

A Reference Sheet containing all the Z80 mnemonics for Opcodes 0-255 identified in decimal, hex and octal for identification is now available.

Included are ASCII code identification of printer control codes, keyboard characters, graphics codes, space compression (tab) codes, as well as Basic's reserved-words token codes.

In addition, the Reference Sheet contains four number-base conversion tables in powers of 2, 16, 2-to-16 conversion, and hex-to-decimal.

The Reference Sheet is free to anyone sending ABS a #10 SASE indicating if for Model I, Model II, Model III. Write to ABS Suppliers, 3352 Chelsea Circle, Ann Arbor, MI 48104.

Reader Service ✓ 553

High Yield Ribbons

A new NEC high-yield multistrike ribbon cartridge is now being marketed. With the addition of a new gear ratio system and by using a five-overstrike formula multistrike ribbon, approximately 100,000 additional characters have been added to the existing NEC cartridges. A total average yield of 325,000 characters per cartridge is now possible.

Aspen Ribbons is also marketing standard NEC Multistrike ribbons in blue, red, green and brown, in addition to black.

Contact Aspen Ribbons Inc., 1700 N. 55th St., Boulder, CO 80301, (303) 444-4050.

Reader Service ✓ 571

The GEAP Inkslinger

The GEAP Inkslinger enables printing with a library of different character sets or creating your own lettersets, character fonts or graphics for unique correspondence. The characters are created using an Epson MX-80 or 100 with the Graftrax option. The GEAP Inkslinger provides the programming to print bit image graphics and the fonts, you just type in the text and give a Write command.

The package includes the tools used in creating Inkslinger letters allowing non-programmers to modify the letters or create their own lettersets or type fonts. Once letters are created they may be printed, stored on disk, or reedited at a later time. In addition, other types of artistic drawings may be created including

ABCDEFGHIJKLMNOPQRSTUVWXYZ

ABCDEFGHIJKLMNPOQRSTUVWXYZ

ABCDEFGHIJKLMNOPQRSTUVWXYZ

ABCDEFGHIJKLMNPOQRSTUVWXYZ

ABCDEFGHIJKLMNPOQRSTUVWXYZ

ABCDEFGHIJKLMNOPQRSTUVWXYZ

ABCDEFGHIJKLMNOPQRSTUVWXYZ

Sample GEAP Inkslinger lettersets

custom logos or graphs. Using a "tile" concept, full page drawings can be created. Print time options allow the manipulation of the bit images into different forms including a magnification option.

The Inkslinger requires a Model I or III, 48K and at least one disk drive and the original GEAP 48K disk version. Introductory price is \$29.99 from J.F. Consulting, 74-355 Buttonwood, Palm Desert, CA 92260, (714) 340-5471.

Reader Service ✓ 570

Data Logging With the Pocket Computer

The Protean Scientific PTR Interface allows using the Pocket Computer as a

portable data-logging device. It transfers your data quickly and easily to a desktop unit.

The Interface reads Pocket Computer data tapes into a Model I or Model III. It is connected directly to the computer's cassette recorder cable and need not be removed during normal cassette operation. An LED flashes to indicate when data transfer is taking place. The unit is battery operated and designed for low power consumption.

The PTR Interface reads both alpha and numeric data. Its format allows loading data files as they occur on the tape or searching for data files by name. You can load complete files or specify the number of memories you want transferred. Checksum errors are reported to identify invalid data.

The package includes the interface, a

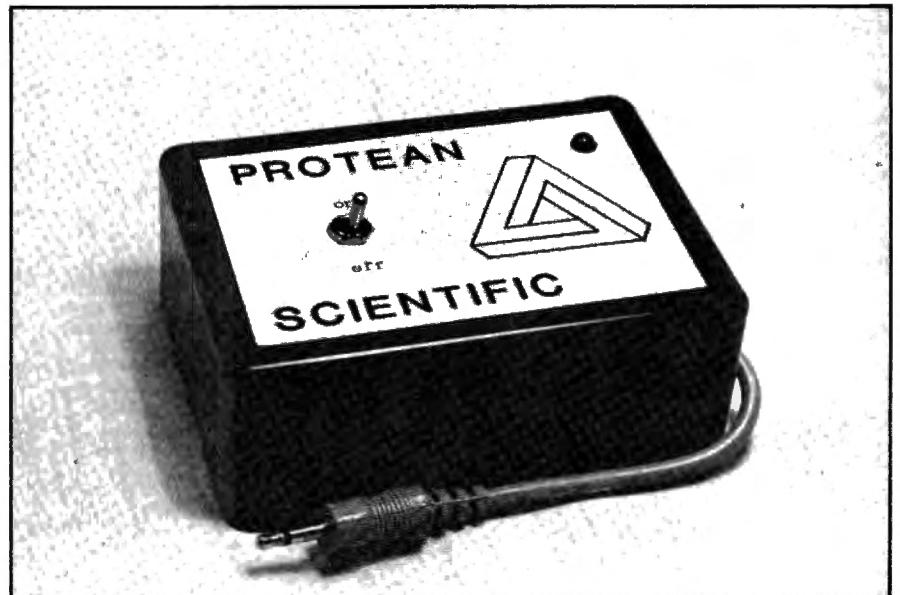

The Protean Scientific PTR Interface

EPSON

PRINTERS & ACCESSORIES

If you buy your EPSON somewhere else you'll probably pay too much!

Common Features of the MX80, MX80FT & MX100 Printers

- * 80 characters per second
- * Replaceable print head by user
- * User programmable from BASIC
- * Bi-directional logic seeking printhead
- * 96 ASCII characters
- * Programmable tabs (vert./horiz.)
- * Cartridge ribbons
- * Self-test mode
- * Tractor/pin feed paper flow
- * Extreme reliability
- * 12 type fonts under software control
- * 9x9 & 9x18 matrix
- * Programmable form feeds
- * Compressed/expanded letters
- * Parallel interface standard
- * Double strike & emphasized modes

MX80... The Printer that started it all. All of the above features plus extreme ease of use. Complete TRS80 block graphics set as well as user selectable international symbols. Gives correspondence quality printing in several user selectable modes. Dip switch pins may be set for dedicated applications. Complete forms programmability from BASIC software.

MX80FT... All the features of the MX80 but with FRICTION feed as well for the use of single sheets of paper or roll paper. An exceptional buy for the user needing the single sheet capability. In the compressed mode 132 characters can be printed across the width of a page which means it can be used for any printouts that normally need a 15 inch wide printer.

MX100... An exceptional printer with an extra quiet printhead and extra heavy duty construction for the intense use of a business environment. Does not have the TRS80 graphic blocks but comes standard with Bit-Image graphics which allow the user control of individual dots for designing specialized graphs, symbols, etc. A best buy for business use.

MX70... For the budget minded an excellent entry level printer. It has most all of the features mentioned above including Bit-Image graphics in place of the TRS80 graphic blocks set. The Printer is unidirectional only. Expandable text can be printed but not compressed. Only single density printings is supported on the MX70. An inexpensive heavy duty printer.

**BEST prices on Epson Printers
All Printers & accessories in STOCK now!!!**

EPSON ACCESSORIES, INTERFACES & CABLES

- GRAPHTRAX 80 option (bit-image/italics) \$79
- CABLE Model I interface & Model III.....\$35
- \$25 if purchased with EPSON printer
- CABLE & INTERFACE to Model I keyboard. \$85
- APPLE interface & cable.....\$89
- GRAPPLER Apple hi resolution graphics. \$CAll
- IEEE interface & cable (CBM/Pet).....\$79
- ATARI cable (must have 850 interface).....\$35
- SERIAL RS232 2k buffered int. card.....\$149
- RS COLOR computer to Epson card/cable. \$59

RIBBONS AND CARTRIDGES IN STOCK NOW

SCALL 800-433-5184

EPSON PACK 2 - GRAFTRAX

version for MX80, 80FT & MX100. This package includes updated versions of modules in original Epson Pack. A screen oriented BIT IMAGE GRAPHICS generator utility is provided. Create your special characters, symbols, etc. directly on your monitor and then send to printer. Printout includes code to generate graphics and will save needed code as BASIC program line to disk. Then MERGE these into your BASIC program. Also demo programs showing use of Bit-Image graphics. Full documentation. **INTRO SPECIAL: \$24.95 with printer or GRAFTRAX. \$34.95 separately. \$7.50 for update of old Epson Pack**

PRINTERS

MATRIX PRINTERS

- EPSON MX70 \$CALL
- EPSON MX80 \$CALL
- EPSON MX80 FT \$CALL
- EPSON MX100 FT \$CALL
- LINE PRINTER VII RS \$325
- NEC 8023A \$495
- C. ITOH 8510 \$495
- OKIDATA 82A \$499
- OKIDATA 82A w/tractor \$559
- OKIDATA 83A \$769
- LINE PRINTER VIII RS \$649
- CENTRONICS 739parallel \$599
- CENTRONICS 739 serial \$749
- OKIDATA 84 / 200 cps \$1295
- LINE PRINTER VI RS \$988
- CENTRONICS 704 \$1559
- ANADEX 9500/01 2k buf. \$1295
- TEXAS INST. 810 Basic \$1595
- LINE PRINTER V RS \$1549
- Centronics 352 / 200 cps \$1795
- Centronics 353 / dual mode, 200cps data proc., 50cps super letter quality \$2495

LINE PRINTERS

- CENTRONICS 6080/81 600 lines per minute high speed band printer. For serious business applications. 6081 standard \$7676 6080 quietized cabinet \$6399

LETTER QUALITY

Daisy Wheel / Spinwriters

- C. ITOH F-10 / 40 cps \$1595
- DAISY WHEEL II RS \$1695
- NEC SPINWRITERS
- 3510 RS232 \$1795
- 3530 Centronics parallel \$1795
- 7710 Read Only \$2375
- 7710 R/O w/tractor \$2575
- 7720 kybd w/tractor \$2750
- 7730 R/O parallel \$2375
- 7730 R/O par. w/tract. \$2575
- DIABLO 630 R/O \$2350
- DIABLO 630 keyboard \$2850
- QUME 9/35 R/O \$1850
- QUME 9/35 keyboard \$1950
- QUME 9/45 limited \$2295
- QUME 9/55 limited \$2395

Interfaces & cables available for most printers with any TRS80, Apple, Atari & most other computers. **\$\$\$CALL FOR PRICES!**

HIGH RESOLUTION MONITOR

- NEC green monitor \$179
- NEC color monitor \$349

ALTOS COMPUTERS \$CALL

TEXAS COMPUTER SYSTEMS

Offers Lowest Prices on

TRS-80



- ★ MODEL II 64k.....\$3248
- MODEL II 1 Drive Expansion...\$995
- MODEL II 2 Drive Expansion...\$1495
- MODEL II 3 Drive Expansion...\$1995
- Radio Shack HARD DISK.....\$3995
- TCS 1 Drive/single cabinet...\$849
- TCS 1 Drive/triple cabinet...\$949
- TCS 2 Drive/triple cabinet...\$1424
- TCS 3 Drive/triple cabinet...\$1899
- TCS uses original Shugart drives
- MODEL 16 1 Drive.....\$4499
- MODEL 16 2 Drive.....\$5199
- DT-1 DATA TERMINAL.....\$629

CORVUS HARD DISKS

CALL FOR PRICES \$\$\$\$

Add 5, 10 or 20 megabytes of storage to your TRS80, Apple, Atari, Heath, Zenith, Intertec, IBM, S-100 and many others. One or several computers can share a hard disk. Get simultaneous access to data for multiple users. Available NOW at SUPER SAVINGS!

DEALERS...You can buy CORVUS from us for less. Call & SAVE.

COLOR COMPUTERS

- Original mfg warranty on these items: TCS 180 day Limited warranty on TCS items:
- 4K Level 1.....\$308
 - 16K Level 1.....\$439
 - 16K Extended Basic.....\$459
 - 32K Extended Basic.....\$569
 - Color Disk 0.....\$499
 - 16K Level 1.....\$369
 - 16K Extended Basic.....\$439
 - 32K Extended Basic.....\$499
 - 32K Upgrade Kit (TCS).....\$79
 - EPSON/COLOR Int.& cable.....\$59

MODEL III SYSTEMS

The following with Radio Shack Warranty:

- Model III 16k.....\$818
- Model III 32k.....\$918
- Model III 48k.....\$1018
- Model III 48k 2 Drives RS232 \$2049
- The following come with quality TCS memory and our own 180 day limited warranty. No warranty when customer opens computer or adds internal components.
- MODEL III 16k TCS.....\$788
- MODEL III 32k TCS.....\$818
- MODEL III 48k TCS.....\$848

MODEL III DISK EXPANSION KITS

We use the highest quality fiberglass **CONTROLLER BOARDS** with double sided glass epoxy board and gold plated contacts in our TCS systems. The finest switching **POWER SUPPLY** available is also provided. The aluminum **MOUNTING HARDWARE** has slotted holes for easy installation of the drives and includes all the power and data cables necessary to install the controller, drives and power supply.

Our **DISK DRIVES** are made by Tandon the same company that makes the drives used by Radio Shack. These drives are 40 track, double density, 5 millisecond stepping rate and are fully burned in for 48 hours. These drives have the same specifications as the drives used by Radio Shack. No soldering or modifications to existing circuitry is necessary. The following kits are available:

- KIT 1 Controller, Power Supply & Mounting Hardware.....\$379
- KIT 2 Controller, Power Supply, Hardware & 1 Disk Drive.....\$595
- KIT 3 Controller, Power Supply, Hardware & 2 Disk Drives.....\$819
- KIT 4 One Tandon Disk Drive (bare drive only).....\$219
- KIT 5 16K of High Quality TCS Memory chips.....\$49.95
- KIT 6 32k of High Quality TCS Memory chips.....\$79.95

MODEL III 48k 2 DISK DRIVES ... \$1795

Above KIT fully assembled, with 48 hour burn-in test & 180 day TCS Limited Warranty!!

CUSTOM SOFTWARE FROM TCS

Completely integrated **BINARY SEARCH TREE** programs now available. This series of programs fully implements the B-TREE structures including INSERTION, DELETION, EDITING & TRAVERSAL. No more sorting or long data file searches and yet files can be larger than memory. Duplicate keys are fully supported. Files can be retrieved in sorted order via B-TREE Traversal. Each of the programs come with fully commented source code so that you can use the modules in your own programming.

- B-TREE Library (organize your home library keyed by author).....\$39.95
- B-TREE Video (organize your video cassette library, prints labels, etc.).....\$39.95
- B-TREE Mailing List (keyed by name or zip, label printing, etc.).....\$49.95

For fast efficient service. **Heart of** we can air freight from Dallas

TEXAS COMPUTER SYSTEMS

P.O. Box 1327 Arlington, Texas 76004-1327

★ Toll Free Number 800 433-5184

Texas Residents 817 274-5625

- Payment: Money order, cashiers or certified check. Prices above reflect 3% cash Discount
- Call for Visa/MC card prices.
- Prices subject to change at any time
- No Tax out-of-state. Texans add 5%.
- Many items shipped FREE. Call for quote.

NEW PRODUCTS

cassette tape with Assembly-language and Basic programs, and manual. The software requires 16K, 32K or 48K of memory. The package is priced at \$99.95 and is available from Protean Scientific, Route 13, Lincoln, NE 68527.

Reader Service \blacktriangleright 565

Stock Trackers

A new generation of Stock Tracker programs for the Model I and III are now available.

Modules include comprehensive graphics, data editing and several new reports. A new trading logic is featured for direct integration with the optional companion program, Market Tracker. All programs and subcommands are list selectable, include extensive error trapping, execute faster, and can be repeated or aborted.

The program requires 48K and one disk drive. They retail for \$285 and may be purchased through H & H Trading Company, Box 549, Clayton, CA 94517, (415) 672-3233.

Reader Service \blacktriangleright 567

Automatic Curve Plotter

Autoplot provides high-resolution graphics capabilities for Model I and III owners. Using an Epson MX-80 or

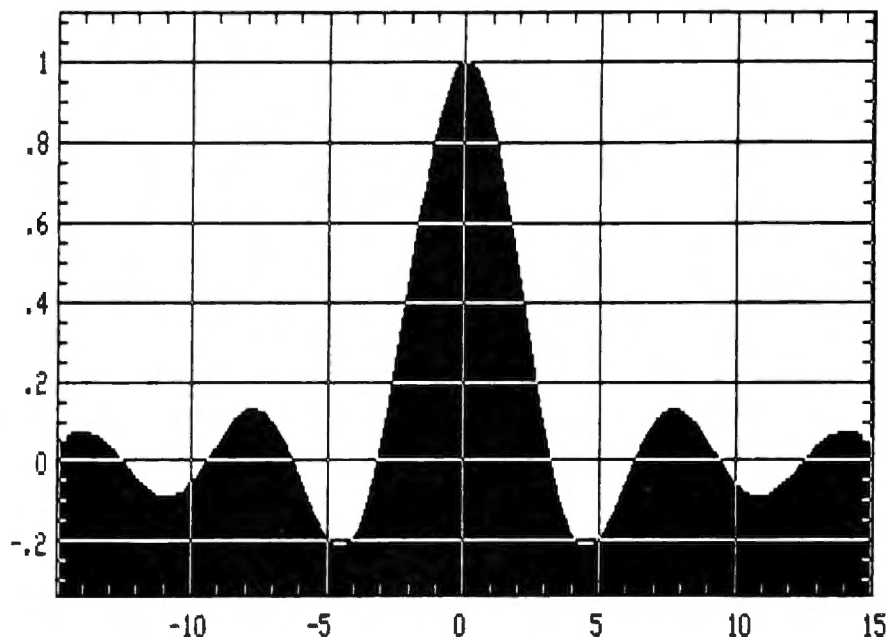

Sample Autoplot graph.

MX-100 printer and Grafrax as an output device, this curve-plotting program creates graphs with a resolution of 480 by 192 dots.

Autoplot is written in Disk Basic and enhanced by machine-language routines in high RAM. Data points are entered with a small user-written Basic subroutine. By selecting options, you can override the automatic scaling of the axes, plot continuous curves or separated markers, choose linear or logarithmic presentation, request a grid overlay, compute derivatives or integrals, plot more than one curve, or select from four different print sizes and formats.

The package is available for the Model I and III (48K, 1 disk drive) for \$79.50. For more information, contact Menlo Systems, 3790 El Camino Real, Palo Alto, CA 94306, (415) 327-7424.

Reader Service \blacktriangleright 550

High Contrast Electro-sensitive Paper

A whiter matte finish is now available with Dennison Manufacturing's Electro-sensitive paper for non-impact printers.

By combining a white matte surface finish with black undercoating a contrast is produced for high legibility. The paper can be ordered in all standard plus custom printer sizes. Perforated paper, a variety of colors, pressure-sensitive adhesive for labeling, and other options are also available.



High Contrast Electron Sensitive paper.

Contact Dennison Manufacturing Company, Technical Papers Division, 300 Howard St., Framingham, MA 01701, (617) 879-0511.

Reader Service \blacktriangleright 590

The Coupon Shopper

The Coupon Shopper keeps organized records of redeemable coupons.

The program stores up to 99 coupons, their brand names, values, and expiration dates. Coupons can be added and deleted as necessary. This product also prepares shopping lists from the program's 160 grocery items (20 additional items may be added by the user). When preparing your shopping list a symbol appears next to the items you have entered a coupon for. After preparing the shopping list, coupon deductions are totalled up at the bottom of the screen.

This program is available on cassette for the Model I and III, for \$9.95 by contacting V. Bertrand, Box 217, Wallingford, CT 06492.

Reader Service \blacktriangleright 564

TextPro For the Color Computer

TextPro is a complete text editor and text processing program for the Color Computer.

The entire program utilizes only 6K of memory including the tape, screen and keyboard buffers. Its fast editing and processing is compatible with Basic ASCII formatted tape and disk files.

The editor itself includes 24 commands including string search and replace, line

Wayne Green Books

NEW
ARRIVALS

TEXTEDIT

a complete
word processing
system in kit
form.

by
Irwin Rappaport

A WAYNE GREEN
PUBLICATION

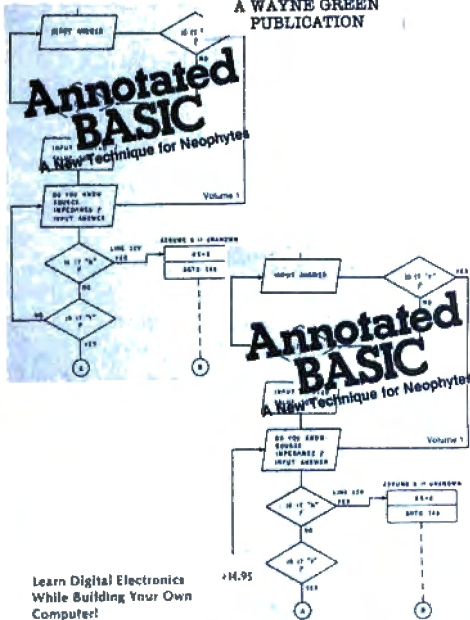

Learn Digital Electronics
While Building Your Own
Computer!



*TRS-80 is a trademark of
Radio Shack Division of Tandy Corp.

TEXTEDIT—A Complete Word Processing System in kit form by Irwin Rappaport

TEXTEDIT is an inexpensive word processor that you can adapt to suit your needs, from writing form letters to large texts. It is written in modules, so you can load and use only those portions that you need. Included are modules that perform:

- right justification
- ASCII upper/lowercase conversion
- one-key phrase entering
- complete editorial functions
- and much more!

TEXTEDIT is written in TRS-80* Disk BASIC, and the modules are documented in the author's admirably clear tutorial writing style. Not only does Irwin Rappaport explain how to use TEXTEDIT; he also explains programming techniques implemented in the system.

TEXTEDIT is an inexpensive word processor that helps you learn about BASIC programming. It is written for TRS-80 Models I and III with TRSDOS 2.2/2.3 and 32K. *TRS-80 and TRSDOS are trademarks of the Radio Shack Division of Tandy Corporation. **BK7387 \$9.97 ISBN 0-88006-050-6 Disk Available DS7387 \$19.97**

Annotated BASIC—A New Technique for Neophytes.

BASIC programming was supposed to be simple—a beginner's programming language which was so near to English that it could be easily understood. But, in recent years, BASIC has become much more powerful and therefore much more difficult to read and understand. BASIC simply isn't basic anymore.

Annotated BASIC explains the complexities of modern BASIC. It includes complete TRS-80* Level II BASIC programs that you can use. Each program is annotated to explain in step-by-step fashion the workings of the program. Programs are flowcharted to assist you in following the operational sequence. And—each chapter includes a description of the new concepts which have been introduced.

Annotated BASIC deals with the hows and whys of TRS-80 BASIC programming. How is a program put together? Why is it written that way? By observing the programs and following the annotation, you can develop new techniques to use in your own programs—or modify commercial programs for your specific use.

Annotated BASIC Volume 1 contains Projecting Profits, Surveyor, Things to Do, Tax Shelter, Introduction to Digital Logic, Camelot, The Soundex Code, Deduction, Op Amp, Contractor Cost Estimating **BK7384 \$10.95 ISBN 0-88006-028-X**

Annotated BASIC Volume 2 contains Rough Lumber List, Trip Mileage, Flight Plan, OSCAR Data, SWR/Antenna Design, Supermaze, Petals Around the Rose, Numeric Analysis, Demons, Air Raid, Geography Test, Plumbing System Design. **BK7385 \$10.95 ISBN 0-88006-037-9**

Order Both Volumes and Save! BK738402 \$18.95

Kilobaud Classroom—

A practical course in digital electronics

by George Young and Peter Stark

Learning electronics theory without practice isn't easy. And it's no fun to build an electronics project that you can't use. *Kilobaud Classroom*, the popular series first published in *Kilobaud Microcomputing*, combines theory with practice. This is a *practical* course in digital electronics. It starts out with very simple electronics projects, and by the end of the course, you'll construct your own working microcomputer!

Authors Young and Stark are experienced teachers, and their approach is simple and direct. Whether you're learning at home or in the classroom, this book provides you with a solid background in electronics—and you'll own a computer that you built yourself!

Kilobaud Classroom contains Getting the Ball Rolling, Gates and Flip-Flops Explained, J.K. Flip-Flops and Clocked Logic, PC Boards and Power Supplies, Hardware Logical Functions, Voltage, Current and Power Supplies, Transistors, Diodes and OP Amps, Pulses and More Pulses, Counters and Registers, Bus Traffic Control, ROM and RAM Memories, I/O Circuitry, Parallel and Serial I/O Ports, Computer I/O III, Computer I/O IV, Computer I/O V, Processor Connections, Finally... The Kilobaud Crescendo, Eproms and Troubleshooting, Expansions and Programming, Machine-Language Programming, Assembly-Language Programming, Connecting to the Outside World.

ISBN 0-88006-027-1 **BK7386 \$14.95**

FOR TOLL-FREE ORDERING CALL 1-800-258-5473
WAYNE GREEN BOOKS • PETERBOROUGH NH 03458

Use the order card or itemize your order on a separate piece of paper and mail to Wayne Green Books Attn: Sales • Peterborough NH 03458. Be sure to include check or detailed credit card information. (Visa, Master Charge or American Express accepted.) No C.O.D. orders accepted. All orders add \$1.50 for the first book, postage and handling; \$1.00 each additional book; \$10.00 per book foreign air mail. Please allow 4-6 weeks after publication for delivery. Questions regarding your order? Please write to Customer Service at the above address.

NEW PRODUCTS

and automatic line-edit modes allowing you to insert, delete, change or add characters. The text processor includes 29 commands for formatting the output.

For more detailed information contact Cer-Comp, 5566 Richochet Ave., Las Vegas, NV 89110, (702) 452-0632. TextPro is priced at \$49.95.

Reader Service ✓ 595

Small Business Package

A small business package, Mailpack, has been introduced for the Model I and III with a minimum of 32K and two disk drives.

The package combines the best features of Kwikrite, a simplified letter and text-writing set of programs; Docurite, a multi-page, comprehensive word processor; Customer, a specialized data base manager; and Mailsome, a new interfacing program. The operation of Mailpack software is fully interactive with the master menu and sub-menus of each module (which can be purchased and used separately.)

The total Mailpack software is available for \$149.95 from Simplified Software Systems, 118 Third Ave., N.W. Box 1192, Hickory, NC 28601.

Reader Service ✓ 594

Encyclopedia Loader

The Encyclopedia Loader was designed to save the monotonous typing of all *Encyclopedia for the TRS-80* programs into your computer.

The Loader is produced as each volume of the series goes to press. The Level II Basic cassette contains the majority of the programs for the volume it accompanies. A sample of the programs include business, education, graphics, home applications, tutorials and utilities.

Individual Encyclopedia Loaders retail for \$14.95 and are available from Wayne Green Books, Peterborough, NH 03458, (800) 258-5473.

Reader Service ✓ 586.

Form80/Data80

Form80/Data80 is a data base management system with an applications generation program, a report generation subsystem, and a letter-writing subsystem.

Form80, the applications generation program, allows persons with no prior

computing experience to sit down and write their own data base management application quickly.

Data80, the data base manager, allows the user to collect information on his application using five basic commands. Reports may be also run against the data base using the on-line report generator. A word processor, text editor and letter writing subsystem are featured. Data80 needs a maximum of three disk accesses to find any record on system regardless of the length.

These programs have a combined price of \$995 and operate on any system running CP/M. Contact Alpha Data Inc., 417 Welshwood Dr., Suite 103, Nashville, TN 37211, (615) 333-1934.

Reader Service ✓ 574

Trashman

Trashman is an arcade-style game for the Model I and III with 16K which tests your skill as you guide a little "critter" from the Coalsack Nebula around the halls of the Deneb IV Haladay Inn devouring the trash left behind by careless guests.

While you are avoiding the alien pets that also have been left wandering the halls, search for Dr. Peppo's Elixir of Health and Vitality and become "Super Trashman!"

Trashman retails for \$14.95 from Creative Thaumaturgy, Box 107 Forrest Park Branch, Dayton, OH 45405.

Reader Service ✓ 596

Earthquake— A New Adventure

Earthquake is the latest in Adventure International's Other-Venture Series.

Crafted with attention to historical accuracy and detail, Earthquake returns you to San Francisco on April 19, 1906. The city streets are awash with flame as buildings burn and crumble. You are left to test your survival skills.

The tape version of the program is \$19.95, the disk version \$20.95. Both are available from Adventure International, Box 3435, Longwood, FL 32750, (305) 862-6917.

Reader Service ✓ 585

Direct Plug Isolators

The Direct Plug Isolators provide the same equipment interaction isolation and power-line protection as the line-cord Isolator series. A retention screw prevents accidental withdrawal from the wall socket.

Direct Plug Isolators can accommodate a total 1,875-watt load, with up to 1,000 watts per socket. A high-capacity spike/surge suppressor is designed into each unit. The Direct Plug Super Isolator, Model DP-SIS032, provides two super-isolated channels for \$96.95.

Contact the Electronic Specialists Inc., 171 S. Main St., Box 389, Natick, MA 01760, (617) 655-1532, for more information.

Reader Service ✓ 554

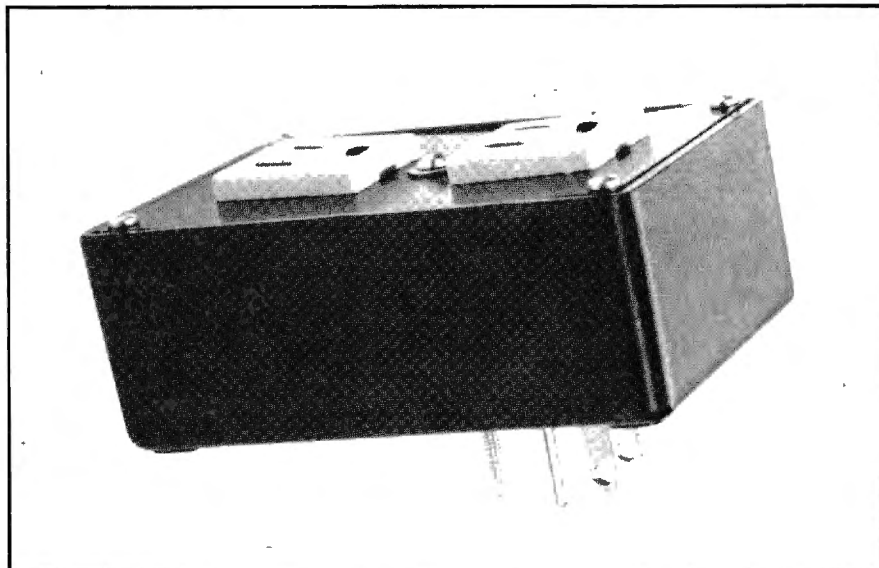

- A Direct Plug Isolator

HOW TO USE YOUR EPSON WITHOUT WASTING COMPUTER TIME:

Your computer is capable of sending data at thousands of characters per second but the Epson can only print 80 characters per second.

This means your computer is forced to wait for the printer to finish one line before it can send the next. A waste of valuable time.

THE NEW MICROBUFFER™ ACCEPTS DATA AS FAST AS YOUR COMPUTER CAN SEND IT.

Microbuffer stores the data in its own memory buffer and then takes control of the printer. This frees your computer for more productive functions.

PARALLEL OR SERIAL.

Microbuffer model MBP-16K is a Centronics-compatible parallel interface with 16,384 bytes of on-board RAM for data buffering.

The MBS-8K is a full-featured RS-232C serial interface with both hardware and software (X-On/X-Off) handshaking, baud rates from 300 to 19,000 and an 8,192 byte RAM buffer.

SIMPLY PLUG IT IN.

Either model fits the existing auxiliary interface connector inside the Epson MX-80, MX-80 F/T or MX-100 without modification, and is compatible with standard Epson cables and printer control software, including GRAFTRAX-80.

JUST \$159.00*

When you think how much time Microbuffer will save, can you afford *not* to have one? Call us for your nearest dealer.

PRACTICAL PERIPHERALS, INC.

31245 LA BAYA DRIVE, WESTLAKE VILLAGE, CA 91362 • (213) 991-8200

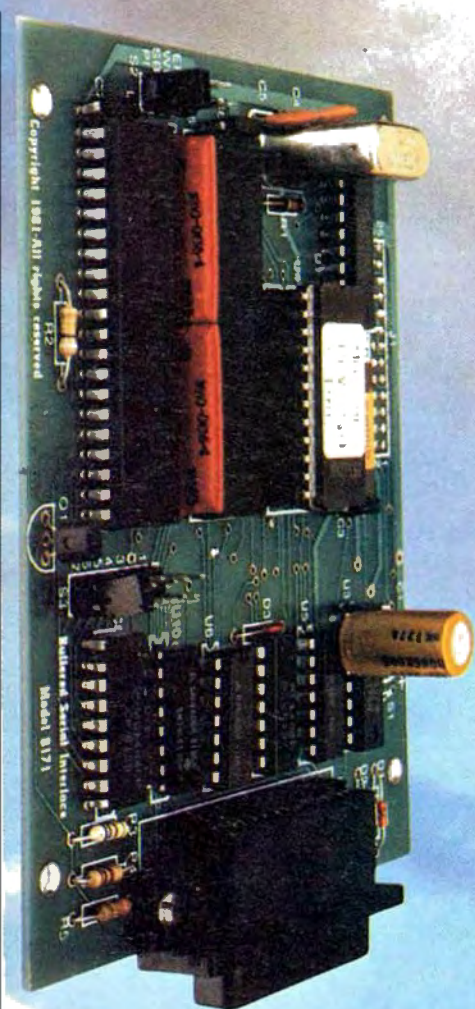
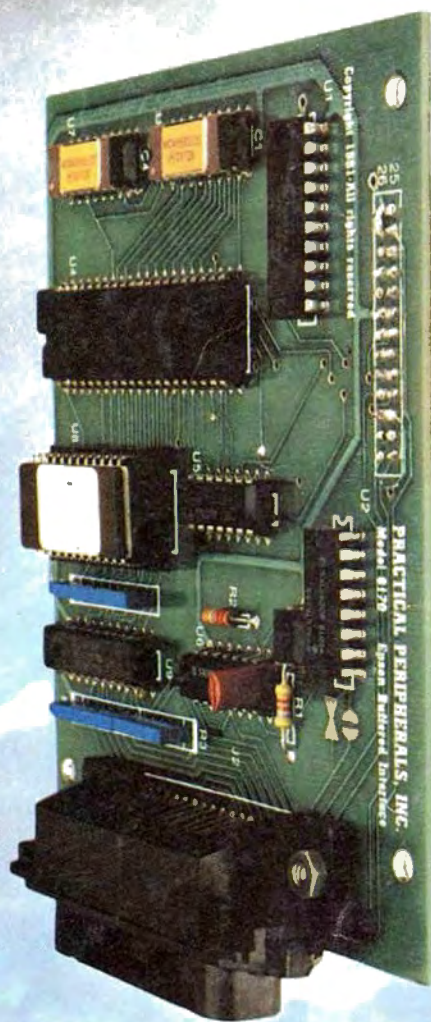

TIRED OF WAITING?

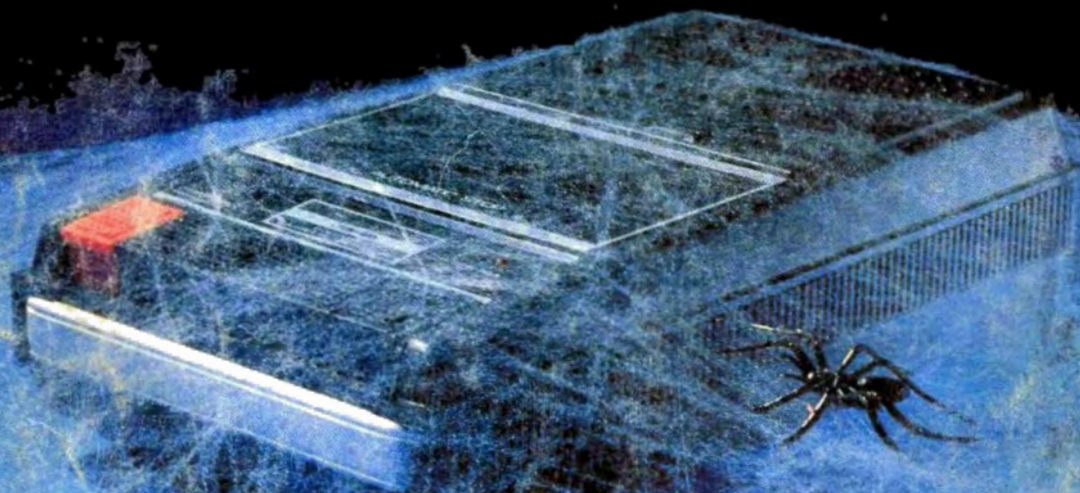

Frustrating isn't it! No matter how much you speed up your program it still seems to take forever to save data onto a cassette. Wouldn't it be great if someone could design a mass storage system with the speed of a disk, but at half the cost? Exatron did, the *Exatron Stringy Floppy (ESF)*.

Totally self-contained, the ESF is an extremely fast, reliable, and economical alternative to cassette or disk storage of programs or data. All of the ESF's operations are under the computer's control, with no buttons, switches, knobs or levers to adjust or forget.

The ESF uses a miniature tape cartridge, about the size of a business card, called a wafer. The transport mechanism uses a direct drive motor with only one moving part. Designed to read and write

digital data only, the ESF suffers from none of the drawbacks of cassettes - without the expense of disks.

Several versions of the ESF are available, for the *TRS-80*, *Apple*, *PET*, *OSI* and an *RS 232* unit. Even the slowest of the units is 15 times faster than a cassette, and all are as reliable as disk drives - in fact a lot of users say they are *more* reliable!



excellence in electronics

exatron

To get further information about the ESF give Exatron a call on their Hot Line 800-538 8559 (inside California 408-737 7111).

If you can't wait any longer then take advantage of their 30 day money-back guarantee, you've nothing to lose but time!

181 Commercial Street
Sunnyvale, CA 94086

